

University of New Orleans
ScholarWorks@UNO

University of New Orleans Theses and
Dissertations

Dissertations and Theses

8-9-2006

Synthesis of Water Soluble Quantum Dots and their Application for Enzymatic Activity Measurements

Ying Long
University of New Orleans

Follow this and additional works at: <https://scholarworks.uno.edu/td>

Recommended Citation

Long, Ying, "Synthesis of Water Soluble Quantum Dots and their Application for Enzymatic Activity Measurements" (2006). *University of New Orleans Theses and Dissertations*. 408.
<https://scholarworks.uno.edu/td/408>

This Thesis is protected by copyright and/or related rights. It has been brought to you by ScholarWorks@UNO with permission from the rights-holder(s). You are free to use this Thesis in any way that is permitted by the copyright and related rights legislation that applies to your use. For other uses you need to obtain permission from the rights-holder(s) directly, unless additional rights are indicated by a Creative Commons license in the record and/or on the work itself.

This Thesis has been accepted for inclusion in University of New Orleans Theses and Dissertations by an authorized administrator of ScholarWorks@UNO. For more information, please contact scholarworks@uno.edu.

Synthesis of Water Soluble Quantum Dots and their Application for
Enzymatic Activity Measurements

A Thesis

Submitted to the Graduate Faculty of the
University of New Orleans
in partial fulfillment of the
requirements for the degree of

Master of Science
in
The Department of Chemistry

by

Ying Long

B.S. Chongqing University, Chongqing, China, 1999
M.S. Chongqing University, Chongqing, China, 2003

August 2006

ACKNOWLEDGMENTS

I would like to express my gratitude to my supervisor, Professor Zeev Rosenzweig, whose expertise, understanding, and patience, added considerably to my graduate experience.

I would like to give my special thanks to:

- Professor Nitsa Ronsenzweig for her patience and encouragement in my study and life.
- Other members of my committee, Professor Richard Cole and Professor Guijun Wang for their advice and discussion on my research work.
- All my past and present group members for their support in our lab. Especially, Lifang Shi, Georgeta Crivat, Dr. Silvia De Paoli Lacerda, and Dr. Vania De Paoli for their friendship in those hard days after Hurricane Katrina.
- My close friends: Lifang Shi, Ming Zhang, Xiaobo Gu, Yan Wu, Lei Miao, Yizhong Wang, Suhong Zhang for their caring and support through the years in University of New Orleans.

At last, I would like to dedicate this thesis to my beloved family: father, mother, sister and her twin daughters.

TABLE OF CONTENTS

Abstract.....	v
Chapter 1 Introduction and Background.....	1
1.1 Objectives and Aims.....	1
1.2 Significance and Impact.....	1
1.3 Fluorescence Principle.....	2
1.3.1 Jabłoński Diagram.....	2
1.3.2 Fluorescence Resonance Energy Transfer.....	4
1.4 Characteristics of QDs.....	5
1.4.1 Structural Properties of QDs.....	6
1.4.2 Optical Properties of QDs.....	8
1.5 Synthesis and Capping Strategies of QDs.....	9
1.6 Synthesis of Water – Soluble QDs.....	11
1.7 QDs FRET-Based studies.....	12
1.8 Work Statement.....	14
Chapter 2 Experimental.....	15
2.1 Material and Reagents.....	15
2.2 Optical measurement Instrumentation.....	16
2.3 Synthesis of TOPO Coated CdSe/ZnS QDs.....	16
2.4 Test of QDs FRET-Based Probes in Solution.....	17
2.5 Syntheses of Water – Soluble QDs.....	17
2.5.1 Direct Attachment of Peptides to QDs Surface.....	17
2.5.2 QD-Mercaptoacetic Acid.....	18
2.5.3 Co-coupling Positive Peptide and PEG on QDs.....	19
2.6 Effect of pH on FRET Using Enzymatic Activity in Enzymatic Assay.....	19
Chapter 3 Results and Discussion.....	20
3.1 TOPO Coated CdSe/ZnS QDs.....	21
3.2 FRET between QDs and Rhodamine.....	22
3.3 Synthesis of Water – Soluble QDs.....	23
3.3.1 Direct Attachment of Peptides to QDs Surface.....	23
3.3.2 QD-Mercaptoacetic Acid.....	26
3.3.3 Co-coupling Positive Peptide and PEG on QDs.....	29
3.4 Effect of pH on FRET Using Enzymatic Activity in Enzymatic Assay.....	35

3.4.1 Effect of PH to the FRET system	35
3.4.2 Effect of pH on Enzymatic Activity in QDs-peptide-Rhodamine FRET System.....	36
Chapter 4 Summary	40
References.....	44
Vita	49

ABSTRACT

Luminescent Quantum Dots (QDs) intrigue the interest of researchers with their properties of high quantum yield, broad absorption and narrow emission spectra. Since prepared in organic solvents, QDs are not suitable for biological systems. In my study, several methods of “cap exchange” were tested to enable forming water – soluble QDs with minimal aggregation. The QD-mercaptoacetic acid is simple to synthesize and has good water-solubility, but the QDs are not stable. The direct attachment of peptide molecules to the QDs can passivate the surface and enable water solubility of QDs. It is only applicable for phytochelatin – related peptides, not for all kind of peptides. The co-coupling peptide and PEG on QDs, has good water –solubility when the quantity of PEG and coupling agent EDAC are controlled. The enzymatic activities based on QDs FRET system at different environments was demonstrated and the results show that pH affect the enzymatic activity significantly.

CHAPTER 1 INTRODUCTION AND BACKGROUND

1.1 Objectives and Aims

The main goal of my work was to improve the methods of synthesis of water – soluble quantum dots (QDs), which prevent aggregation when applying QDs in biological system. The water – soluble QDs were used to test the effect of pH on FRET between QDs and Rhodamine using enzyme – based assay.

1.2 Significance and Impact

QDs are semiconducting materials generally synthesized with II-VI or III-V column elements of the periodic table. Due to their high photostability, high emission quantum yield, narrow emission peaks and size-dependent wavelength tunability, these luminescent nanoparticles have been seen as alternative labels to organic fluorophores. QDs have great potential as biological probes for *vivo* imaging of living cells and diagnostics¹.

Since usually synthesized with high – temperature routes in organic solvents, QDs have no aqueous solubility. Aqueous solubility is imperative for the application in biological systems². The first part of my work was to test different ways to synthesize water – soluble QDs and compare their aqueous solubility and luminescence properties.

Fluorescence resonance energy transfer (FRET) is an important signal transduction technique in optical biosensor. It is powerful in probing sub-nanometer scale changes in the separation

distance between donor and acceptor fluorophores, which is ideal for the sensitive detection of molecular binding events and changes in protein conformation in response to interaction with a particular target molecule or to changes in the solution environment.

A crucial aspect of FRET biosensor is the development of optimized donor and acceptor dyes to function in concert with desired recognition elements. Recently, hydrophilic QDs like CdSe-ZnS core-shell nanocrystals have been demonstrated as excellent FRET donors with proximal organic dyes. FRET – based QD biosensor was recently developed in our laboratory for the measurement of the activity of digestive enzyme. FRET-based QD-biosensors could permeate into cells and monitor intracellular processes potentially in real – time. The second part of my work was to investigate the effect of pH to the FRET – based QD biosensor system developed in our laboratory.

1.3 Fluorescence Principle

1.3.1 Jabłoński Diagram

Light absorption and emission and different molecular processes occurring in the excited states during fluorescence are often shown in the Jabłoński Diagrams. In a typical Jabłoński Diagram shown in Fig. 1.1, S_0 , S_1 and S_2 show the singlet ground state, first and second excited states respectively. T_1 is the first triplet state. The light absorbed by a fluorophore excites an electron from the singlet ground state to S_1 or S_2 according to the magnitude of the absorbed energy. This process happens very fast within 10^{-15} s. Then in the next 10^{-12} s, internal conversion usually occurs when the excited fluorophore molecules relax to the lowest vibrational level of S_1 . Since emission typically happens after 10^{-9} s, the molecule can be fully relaxed at the

time of emission, so emission occurs from the lowest vibrational level of S_1 and the fluorescence spectrum is generally independent of the excitation wavelength. The absorption and emission spectra are the mirror images of each other because the electrons excited do not change the nuclear geometry. The process of intersystem crossing occurs when the electrons in the first excited state S_1 transit to the triplet state T_1 . This process will emit phosphorescence which is lower in energy compared to fluorescence³.

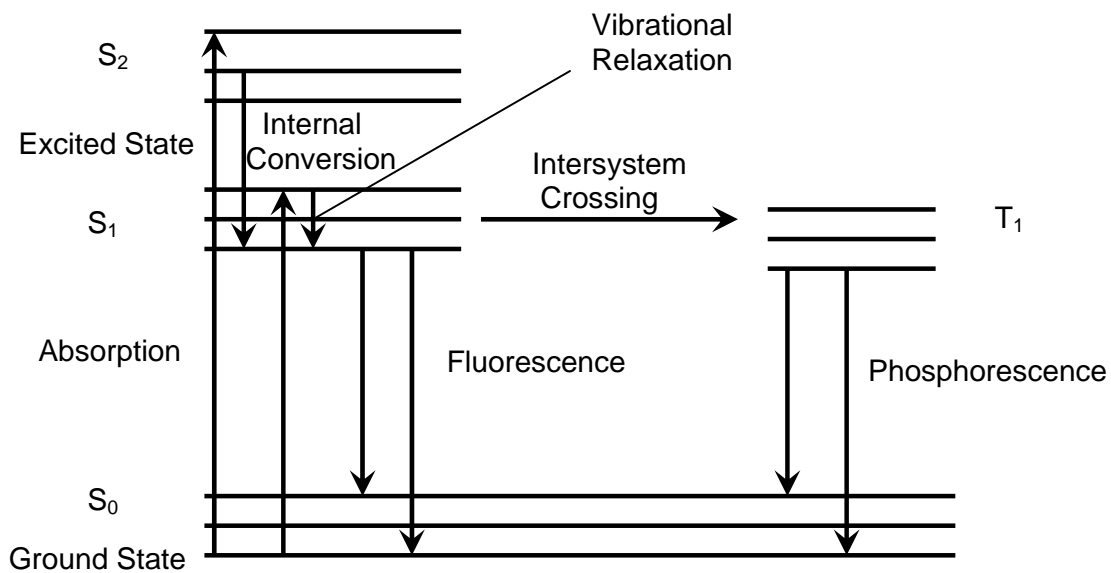

Figure 1.1 Jablonski diagram describing different molecular processes occurring in the excited states during fluorescence. Legend: S_0 , S_1 and S_2 - singlet ground state, first and second excited states; T_1 - the first triplet state.

1.3.2 Fluorescence Resonance Energy Transfer

Fluorescence resonance energy transfer (FRET) is a distance-dependent interaction between the electronic excited states of two dye molecules in which excitation is transferred from a donor molecule to an acceptor molecule without emission of a photon. In FRET, light energy, which is

added at the excitation frequency for the donor fluorophore, transfers some of energy to the acceptor. Then the acceptor re-emits the light at its own emission wavelength. The net result is that since some of the energy gets transferred to the acceptor, the donor emits less energy than it normally would; while the acceptor emits more light energy at its emission frequency. As a result, the fluorescence intensity and lifetime of donor is decreased and shorten, while the acceptor fluorescence is sensitized and its lifetime is longer.

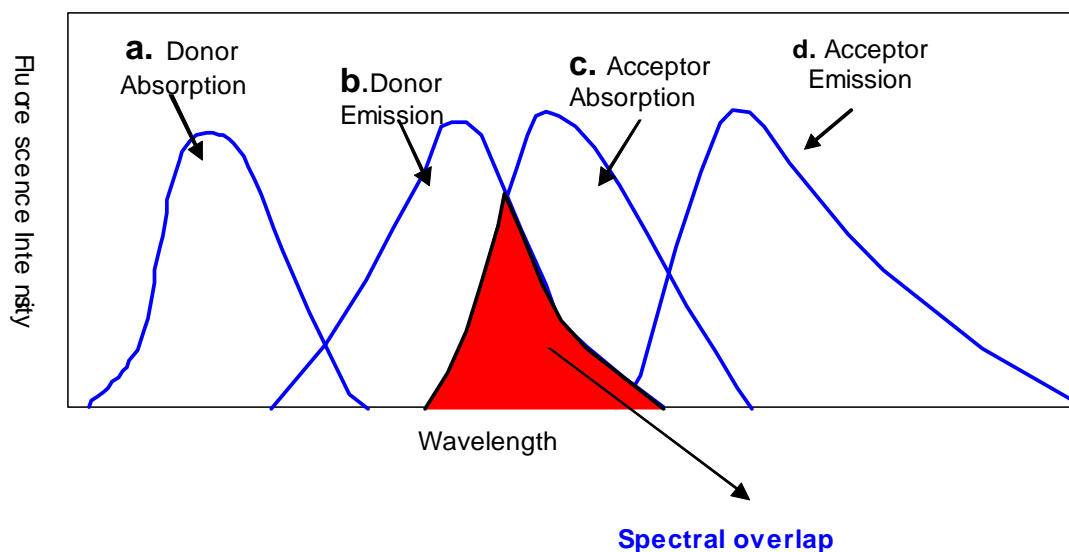

Figure 1.2 Spectral overlap (Marked in red color) between the emission spectrum of the donor and the absorption spectrum of the acceptor. a,b – absorption and emission of donor; c,d – absorption and emission of acceptor.

There are three primary conditions for FRET donor/acceptor pairs: 1) the donor and acceptor molecules must be in close proximity (typically 10-100 Å); 2) The absorption spectrum of the acceptor must overlap with the fluorescence emission spectrum of the donor (Fig. 1.2); 3) Donor and acceptor transition dipole orientations must be approximately parallel⁴. The efficiency of energy transfer is dependent on the extent of spectral overlap between the emission spectrum of the donor and the absorption spectrum of the acceptor, the relative orientation of donor/acceptor

transition dipoles and the distance between the donor and acceptor. FRET is an important technique for investigating a variety of biological phenomena that produce changes in molecular proximity. FRET based sensing assemblies have been used successfully in biological applications including studying protein-protein interactions (binding affinity), protein conformational changes.^{5,6}

1.4 Characteristics of QDs

Semiconductor nanocrystals can be described as a state of matter intermediate between molecular and bulk crystalline. Quantum Dots (QDs) are semiconductors with radii of 1-10 nm, i.e., smaller than the bulk Bohr radius of photoexcited electron-hole pairs in semiconductors (~1-10nm). From quantum mechanical point of view, when the radii of the QDs are smaller than the bulk Bohr excitation radius, the energy bands will be divided into energy levels under the quantum confinement. The small size and high optical activity of semiconductor nanocrystals make them a very interesting material for chemist, physicists, engineers and biologists who are collaborating to study these materials and exploit their properties in many different applications⁷.

1.4.1 Structural Properties of QDs

In the same way that bulk semiconductors are characterized by the structure of their conduction and valence bands as being direct or indirect, so are semiconductor nanocrystals. Direct semiconductor nanocrystals (e.g. CdSe, CdS) are characterized by having the minimum transition energy to promote an electron from the valence band to the conduction band without a change in the electron momentum. The energy of this energy separation is known as the band-gap shown in Fig 1.31⁸. For indirect semiconductors, however, excitation at the band gap energy

must be accompanied by a change in the electron's momentum, which is supplied by a photon^{9,10}.

Although both types of semiconductors are efficient absorbers of light, only direct semiconductors are emissive enough to be used as an optical source or as fluorescent labels (CdSe). The size of the crystal is less than the excitation's Bohr radius. For Si this is 49Å and for CdSe it is 61 Å. Crystallites with diameters smaller than the excitation's Bohr radius are said to be in the Quantum Confined (QC) regime. Quantum confinement has two main consequences: 1) it causes a blue shift in the band gap energy as shown in figure 1.4; 2) it increases the probability of overlap between the electron and hole which increases the rate of radiative recombination¹¹⁻¹².

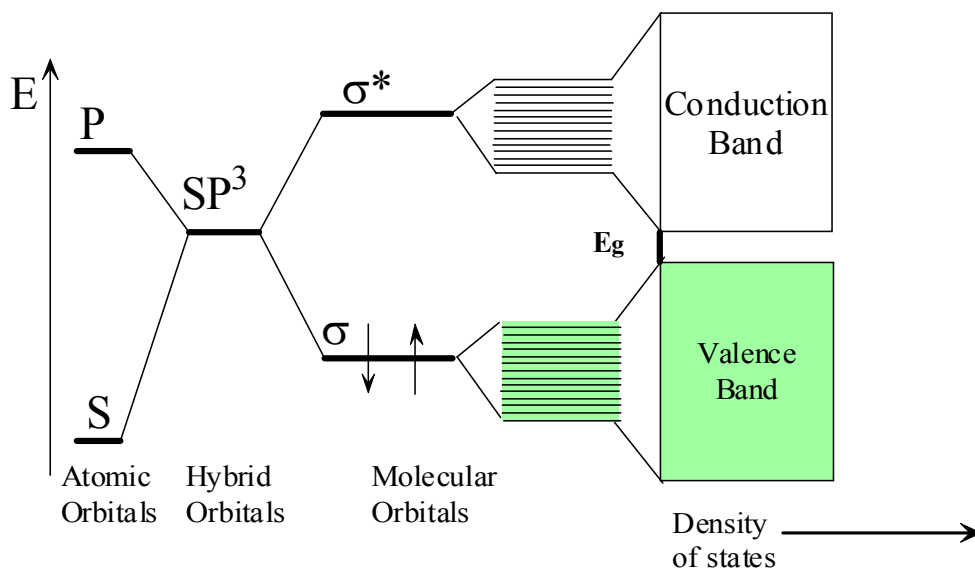

Figure 1.3 Energy level diagram comparing a silicon atom (left), molecular analog (middle) and bulk semiconductor (right). Orbital hybridization leads to the formation of bands and the existence of a band-gap. σ , σ^* - bonding and antibonding molecular orbitals; E_g - bandgap in the bulk semiconductor.

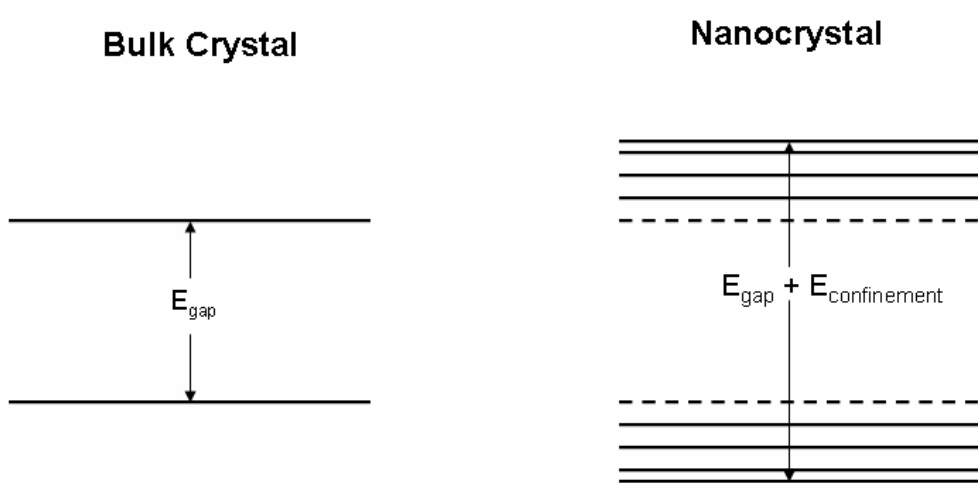

Figure 1.4 blue-shift in the bandgap energy in nm sized geometries with respect to the bulk crystal. E_{gap} - bandgap energy in bulk crystal; $E_{\text{confinement}}$ - blue shift in the band gap energy due to quantum confinement.

1.4.2 Optical Properties of QDs

QDs have several characteristics which distinguish them from conventional organic fluorophores. QDs have different band gap energies with different sizes, so light absorption is a function of size. Since the size and shape of QDs can be precisely controlled by the duration, temperature, and ligand molecules used in their syntheses, QDs show composition- and size-dependent absorption and emission properties. QDs can be synthesized with various types of semiconductor materials (II-VI: CdS, CdSe, CdTe...; III-V: InP, InAs...; IV-VI: PbSe) characterized by different bulk band gap energies.

The creation of an electron - hole pair (i.e., excitation) is a result of absorption of a photon with energy above the semiconductor band gap energy. The probability of absorption increases with higher energies, which result in a broadband absorption spectrum. The radiative recombination of an excitation leads to the emission of a photon in a narrow, symmetric energy

band, so the emission spectra of QDs is fairly narrow as the full width at half-maximum intensity is usually in the range of 20 to 40nm.

For organic fluorophores such as genetically encoded fluorescent proteins or chemically synthesized fluorescent dyes, each fluorophore can only be excited optimally by the light of defined wavelength, which makes it hard to use single excitation sources for multicolor application. Also, organic fluorophore usually have wide emission spectra that tend to spread out more towards the red region called 'red tail'.

For chemists, the most popular QD materials are CdSe and CdS. The absorption onsets are ~ 720 nm and ~ 520 nm for CdSe and CdS respectively, so their absorption energies can be adjusted through the visible region. Therefore CdSe QDs have visible absorption spectra with wavelengths ranging from the red to the violet. The smaller is the size, the shorter the emission wavelength.

Depending on the particle size and the excitation wavelength, the molar extinction coefficients of CdSe QDs are estimated as $\sim 10^5 - 10^6 \text{ M}^{-1} \text{ cm}^{-1}$, which is 10-100 times larger than those of organic dyes. The superior performance in terms of the emission lifetime for QDs compared with commonly used organic dyes has been demonstrated already^{13, 14}.

1.5 Synthesis and Capping Strategies of QDs

QDs can be synthesized in different media such as in aqueous solution¹⁵, reverse micelles¹⁶, polymer films^{17, 18}, sol-gel systems¹⁹ and solvents/ligands²⁰⁻²³, among which the synthesis in Solvents/ligands such as trioctyl phosphine (TOP) / trioctyl phosphine oxide (TOPO) is used

widely. The size and shape of QDs are tunable by altering the duration, temperature, and ligand molecules.

To get QDs with bright luminescence, it is imperative to confine the electrons to the bulk of luminescent QDs. However, surface defects are still formed even under the best reaction conditions. Due to these surface defects, it is possible for electrons to leak from the bulk of the nanocrystals to the surface defects, which results in poor photoluminescence. Additionally, the presence of surface defects broadens the luminescence peaks of QDs²⁴. To alleviate the effect of surface defects and protect surface atoms from oxidation and other chemical reactions, a process called surface passivation was reported where an additional thin layer made of a wider band gap semiconductor material, for example ZnS, grows on the surface of the QDs²⁵⁻²⁹. This process enhances the emission quantum yield and photostability of luminescent QDs.

High-quality colloidal QDs can be achieved by using high-temperature growth solvents/ligands (mixture of trioctyl phosphine / trioctyl phosphine oxide, TOP/TOPO), combined with pyrolysis of organometallic precursors, yielded CdSe QDs with highly crystalline cores and size distributions of 8-11%. Then the reaction combined with appropriate organometallic precursors is further used to overcoat the native CdSe core with a layer of wider-band gap semiconducting material (Fig. 1.8).

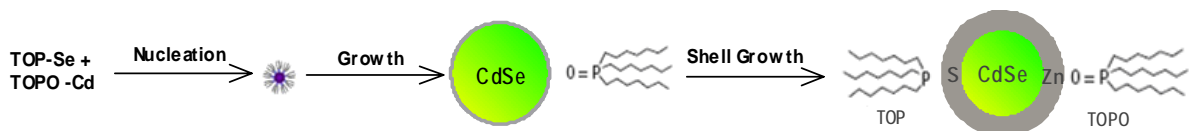

Fig 1.8 Syntheses of CdSe-ZnS with TOPO

Since Murray²⁰ first reported Pyrolysis of organometallic precursors in TOP/TOPO media in 1993, this method has been further developed. The significant improvement was reported by Peng and coworkers²¹⁻²³, who replaced the toxic cadmium precursor Cd(CH₃)₂ with CdO, Cd(Ac)₂ and CdCO₃. Peng's method is used extensively for the syntheses of luminescent QDs. Quantum dot products are now available commercially (Evident Technologies (NY), QDs Corporation (CA)).

1.6 Synthesis of Water – Soluble QDs

With their size-dependent wavelength tunability, narrow and symmetric emission peaks, high emission quantum yield and high photostability, luminescent QDs have been proved to be good alternatives to commonly used organic fluorophores commonly used in aqueous biological systems^{30, 34}. To apply the QDs in aqueous biological systems, the hydrophobic capping ligands of luminescent QDs must be replaced with hydrophilic capping ligands. The phase transfer of QDs to aqueous solutions is realized primarily through 'cap exchange' or encapsulating the original nanocrystals in a thick heterofunctional organic coating. There are three main strategies: (1) 'cap exchange', a process involving the substitution of the native TOP/TOPO with bifunctional ligands, each presenting a surface-anchoring moiety to bind to the inorganic QD surface and an opposing hydrophilic end group³⁰⁻³⁴; (2) formation of polymerized silica shells functionalized with polar groups³⁵⁻³⁶; (3) amphiphilic 'diblock' and 'triblock' copolymers and phospholipids, which interleave the alkylphosphine ligands through hydrophobic attraction, whereas the hydrophilic outer block permits aqueous dispersion³⁷⁻⁴³.

Each of the three strategies mentioned above has advantages and drawbacks. The compact mono – mercapto ligands are simple to synthesize, but are not stable due to the dynamic thiol –

ZnS interactions⁴⁴. Although dithiol dihydrolipoic acid ligands can improve the stability^{31, 34, 44}, almost all carboxyl – terminated ligands limit dispersion to basic pHs⁴⁴. The polymer/phospholipids encapsulation can work over a broader pH range. However since silica shells tend to increase the diameter of CdSe-ZnS from ~ 4-8 nm to ~ 20-30nm, a size that may preclude fluorescence resonance energy transfer (FRET)-based studies⁴⁴. Therefore, ‘cap exchange’ is the predominant method to prepare water-soluble QDs in FRET – based biological applications.

The TOPO ligands groups are often exchanged with thiol functionalized compounds like mercaptoacetic acid (MMA)³⁰, dihydrolipoic acid (DHLA)⁴⁵, and Dithiothreitol(DTT)⁴⁶. Recently cysteine-containing peptides could also be used as effective capping ligands to facilitate the water miscibility of QDs^{47, 48}. Over the past few years, water-soluble CdSe/ZnS luminescent semiconductor QDs have been widely used in immunoassays⁴⁹⁻⁵¹, in situ hybridization^{52,53}, cellular imaging⁵⁴⁻⁵⁶ and in vivo imaging^{57,58} studies as luminescent labels.

1.7 QDs FRET-Based studies

Since FRET is sensitive to molecular rearrangements on the 1-10 nm range, a scale correlating to the size of biological macromolecules, the papers on QDs as FRET donors in biological systems to monitor intracellular interactions and binding events have been reported quickly. By self – assembling acceptor dye – labeled proteins onto Donor surfaces, QDs have two unique advantages over organic fluorophores for FRET: the QD donor emission could be size – tunable to improve spectral overlap with a particular acceptor dye; several acceptors could interact with a single QD donor to improve FRET efficiency. The latter advantage by using a 30 Å radius QD with a dye –labeled protein attached to the QD surface and the dye located at 70 Å from the core.

Assuming the Förster distance (R_0) for this QD donor – dye acceptor pair of 56 Å, the FRET efficiency for a single pair would be 22 %. Increasing the number of acceptors to five, the efficiency could be $\sim 58\%$ ³.

Van Orden and coworkers used CdSe-ZnS QDs as resonance energy transfer donors in a model protein – protein and showed that the specific binding of different proteins can be observed via FRET between a CdSe-ZnS QD donor attached to one of the protein and in a strong enhancement of the dye fluorescence that was well resolved from the QD emission spectrum⁵⁹. Mauro and co-workers have developed FRET-based maltose-binding assays by coating CdSe/ZnS QDs capped with DHLA with maltose binding protein (MBP) molecules. The FRET assay was based on the interactions between MBP and the acceptor cyclodextrin CY 3. Maltose molecules displace the fluorescent cyclodextrin acceptor molecules, which resulted in a maltose concentration dependent increase in the emission of the MBP coated QDs. Hydrophobic CdSe QDs were embedded into lipid membranes as demonstrated with biomimetic vesicles. FRET was seen to a lipid – soluble dye (DiD) and water – soluble dye (Cy 3.5) in which the vesicles were suspended. The degree of energy transfer to each dye demonstrated that most of QDs are located within the lipid⁶⁰⁻⁶³. FRET between streptavidin conjugated QDs and biotinylated gold nanoparticles have also been reported by Oh and coworkers⁶⁴. FRET between QDs and AuNPs can be used for assay of a molecule which inhibits the biomolecular interactions. Goldman et al. developed a hybrid QDs antibody fragment FRET based TNT sensor⁶⁵. Luminescent QDs were conjugated to antibody fragments for the specific detection of the explosive 2, 4, 6-trinitrotoluene (TNT) based on fluorescence resonance energy transfer (FRET) in aqueous environments. Drezek and coworkers developed a novel nanoparticulate luminescent probe, in which QDs are bound to gold nanoparticles by a proteolytically degradable peptide sequence

with FRET⁶⁶. Releases of gold nanoparticles by peptide cleavage restore radiative QD photoluminescence. This probe has great potential in biological applications since its customizable peptide linker sequence can monitor a protease of interest.

1.8 Work Statement

This thesis will use strategy of ‘cap exchange’, which is simple and quick to prepare biocompatible water-soluble QDs. Based on the work of Desheng Wang and Lifang Shi in our lab, the synthesis, and test of the QDs-peptide-Rhodamine FRET system as sensor to enzymatic activity, in which luminescent QDs served as energy donor and Rhodamine red as energy acceptor are introduced briefly. Then the effect of pH on QDs based FRET system using the activity of trypsin is tested.

The thesis addresses the following:

- 1) Synthesis of CdSe –ZnS QDs.
- 2) Improvement of water – solubility of QDs using ‘cap exchange’.
- 3) Testing of effect of pH on QDs FRET system for measuring the activity of trypsin.

CHAPTER 2 EXPERIMENTAL

2.1 Material and Reagents

Cadmium Oxide (CdO, Sigma); Lauric Acid (Sigma); Trioctylphosphine (TOP, Sigma); Trioctylphosphine Oxide (TOPO, Sigma); hexadecylamine (HDA, Sigma); Selenium powder (Sigma); Diethylzinc ($Zn(Et)_2$, Sigma); Hexamethyldisilathiane ($(TMS)_2S$, Sigma); Mercaptoacetic acid (Sigma); Peptide RGDC (American peptide company); Peptide AGSE (American peptide company); Tetramethylammonium hydroxide (TAMOH, Sigma); Dimethyl sulfoxide (DMSO, Sigma); Methanol (Sigma); Pyridine (Sigma); Trypsin (Sigma); Amicon centricon spin dialysis tube (Microcon YM30, Millipore Corp); Rhodamine Red-X, succinimidyl ester 5-isomer (Molecular Probes, Inc); LissamineTM rhodamine B ethylenediamine (Molecular Probes, Inc); Glacial mercaptoacetic acid (Aldrich); Phosphate-buffered saline (PBS) solution (pH 7.4); mPEG-MAL (Nectar); Chloroform (Sigma). All aqueous solutions were prepared with 18 M Ω deionized water produced by a water purification system (Barnstead Thermolyne nanopure) and all chemicals were used as received without further purification.

2.2 Optical measurement Instrumentation

Fluorescence Spectroscopy Measurements - Emission spectra were measured with PTI model QM-1 spectrofluorometer (PTI, Quantamaster, Ontario, Canada), equipped with a with a 75-W continuous Xe arc lamp as a light source.

Digital Fluorescence Microscopy - Luminescence images were obtained with a digital luminescence imaging microscopy system. Primarily used instrument in the research work is inverted fluorescence microscope (Olympus IX-70) equipped with a 100 W mercury lamp as a light source. A 20X microscope objective with NA = 0.9 was used to collect the fluorescence images. To ensure spectral imaging purity, a filter cube with a 450 ± 10 nm band-pass excitation filter, a 505 nm dichroic mirror, and a 515-nm long pass emission filter was used. Digital imaging is obtained with a high-performance ICCD camera (Princeton Instruments, model BH2RFLT3). A PC microcomputer was employed for data acquisition and The Roper Scientific software WinView/32 was used for image analysis.

2.3 Synthesis of TOPO Coated CdSe/ZnS QDs

The trioctylphosphine oxide (TOPO) coated CdSe/ZnS QDs was synthesized based on Wang's method⁶⁷. All the reactions here were under nitrogen gas. 12.7 mg CdO and 160 mg lauric acid were mixed for half an hour under nitrogen gas. The mixture was heated to >220 °C and formed a clear colorless solution indicating the fully dissolved cadmium oxide. 1.94 g TOPO and 1.94 g hexadecylamine (HDA) were added to the solution while stirring and the temperature was raised to ~ 280 °C. The mixture was cooled to ~ 220 °C and 80 mg selenium powder in 2ml trioctylphosphine (TOP) solution was rapidly injected into the solution under vigorous stirring. The temperature was kept at 220°C for 2 minutes and a solution containing 250 μ l hexamethyldisilathiane ((TMS)₂S) and 1 ml diethylzinc (Zn(Et)₂) premixed in 2 ml TOP was gradually injected into the solution. The reaction mixture was kept at 180 °C for one hour. The solution was cooled to room temperature and the resulting sample of CdSe/ZnS QDs was washed three times with methanol and redissolved in chloroform.

2.4 Test of QDs FRET-Based Probes in Solution

Rhodamine Red-X, succinimidyl ester 5-isomer, an amine-reactive dye, can covalently attach to peptide. It can be used as FRET acceptor in an enzymatic activity probe, which has been developed in our lab and can be used to test the feasibility of synthesis of water – soluble QDs in 2.5. The peptide RGDC coated QDs in PBS 7.4 buffer was first prepared using the method in 2.5.1. The QDs-peptide-Rhodamine bioconjugates were prepared by mixing 150 μ l of 4.8 μ M Rhodamine Red-X, succinimidyl ester and 150 μ l of 0.1 μ M peptide coated QDs with PBS 7.4 buffer to 1.5mL, and then incubated at room temperature for 1 hour. The sample was excited at 445nm.

2.5 Syntheses of Water – Soluble QDs

2.5.1 Direct attachment of peptides to QDs surface

1mL of 1 μ M TOPO coated CdSe/ZnS QDs were precipitated with methanol and re-dissolved in 2ml 9:1(V/V) pyridine:DMSO cosolvent. 200 μ l 5mg/mL peptide RGDC in DMSO was added to the reaction mixture. The pH was adjusted to 10 by adding tetramethyl ammonium hydroxide (TAMOH) 20% (w/v) in methanol) to the reaction mixture. The TAMOH molecules were used to form anionic cysteine thiolates to facilitate binding of the peptide to the CdSe/ZnS QDs through the cysteine residues. After centrifugation, the peptide coated QDs were washed in the DMSO co-solvent. Finally, the peptide coated QDs were suspended in a phosphate buffer solutions (PBS) at pH 7.4. Unbound peptide molecules were removed by two repeated cycles of spin dialysis using an amicon centricon spin dialysis tube with a cutoff molecular weight of 30kDa. In each spin dialysis cycle the sample was centrifuged at 2000 rpm for 20 minutes and

washed with the PBS solution. The peptide coated QDs were kept at 4°C in the PBS 7.4. The QDs-peptide-Rhodamine bioconjugates were prepared as described in 2.4.

2.5.2 QD-Mercaptoacetic Acid

1ml ~1.0µM colloidal QDs were dissolved in chloroform and were reacted with 5ml µM glacial mercaptoacetic acid with vigorous stirring overnight. PBS 7.4 solution was added to this reaction mixture at a 1:1 volume ratio. After vigorous shaking and mixing, the chloroform and water layers separated spontaneously. The aqueous layer, which contained mercaptoacetic coated QDs, was extracted. Excess mercaptoacetic acid was removed by four or more rounds of centrifugation. Then 1ml 1.0µM mercaptoacetic coated QDs in PBS 7.4 solution were mixed with 200µl 5mg/mL peptide RGDC in PBS 7.4 solution using 100mM *N*-Ethyl-*N'*-(3-dimethylaminopropyl) carbodiimide hydrochloride (EDAC) as coupling agent. Unbound peptide molecules were removed by two repeated cycles of spin dialysis using an amicon centricon spin dialysis tube with a cutoff molecular weight of 30kDa. The peptide coated QDs were kept at 4°C in the PBS 7.4. The QDs-peptide-Rhodamine bioconjugates were prepared as described in 2.4.

2.5.3 Co-coupling positive peptide and PEG on QDs

Mercaptoacetic acid – coated QDs in PBS 7.4 solution from QD-TOPO were made with method described in 2.5.2. 1ml 1mg/ml PEG with Maleimide (mPEG-MAL) in PBS 7.4 solution was directly added to a solution of 1ml ~1.0µM mercaptoacetic acid-coat QDs in PBS buffer 7.4 and incubated overnight at room temperature. The excess PEG is removed by two repeated cycles of spin dialysis using an amicon centricon spin dialysis tube with a cutoff molecular weight of 30kDa. Afterward, 200µl 5mg/mL peptide AGSE in PBS 7.4 solution and 100mM

EDAC were added to the PEG/QDs solution and incubated overnight at room temperature. The peptide and PEG co-coated QDs were kept at 4°C in the PBS 7.4. The QDs-peptide-Rhodamine bioconjugates were prepared as described in 2.4. Here Rhodamine is LissamineTM rhodamine B ethylenediamine, which is a carboxylic-reactive dye.

2.6 Effect of pH on FRET Using Enzymatic Activity in Enzymatic Assay

In this experiment, 500ul of 1 mg/ml trypsin were added to 500ul QDs-peptide-Rhodamine bioconjugates in buffer with a total volume of 1mL. The pH of the buffer was 5.6, 7.4 and 8.7.

CHAPTER 3 RESULTS AND DISCUSSION

Our lab developed for the first time QD based enzymatic activity probes, whose schematic diagram is showed in figure 3.1. First, the TOPO ligands on the surface of QDs are exchanged with the tetra peptide RGDC, which contains cysteine as effective capping ligands to facilitate the water miscibility of QDs. Then, the peptide coated QDs are labeled with Rhodamine, and FRET happens between the QDs (donor) and the Rhodamine molecules (acceptor). But when the peptide is cleaved enzymatically, the FRET between the QDs and the Rhodamine molecules is diminished.

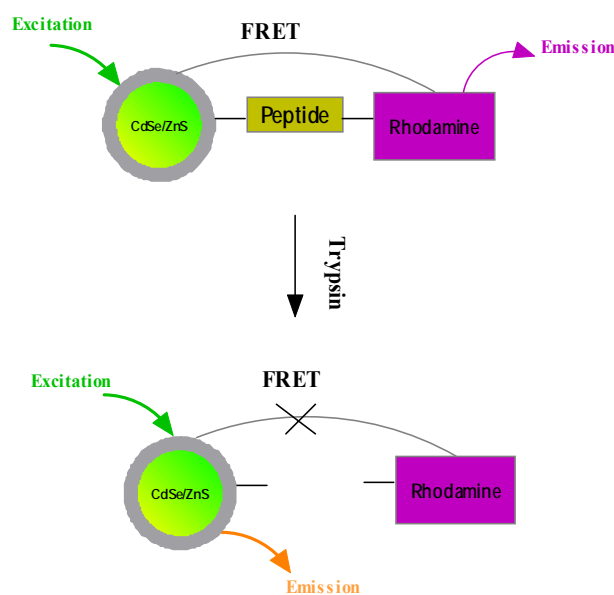

Figure 3.1 Schematic diagram of the principle of QDs based enzymatic activity probes

In my work, different methods were tested to prepare water – soluble QDs by using “cap exchange” strategy, which would be helpful in solving the problem of aggregation of the QDs in FRET system. Then the effect of pH on the FRET system was tested.

3.1 TOPO Coated CdSe/ZnS QDs

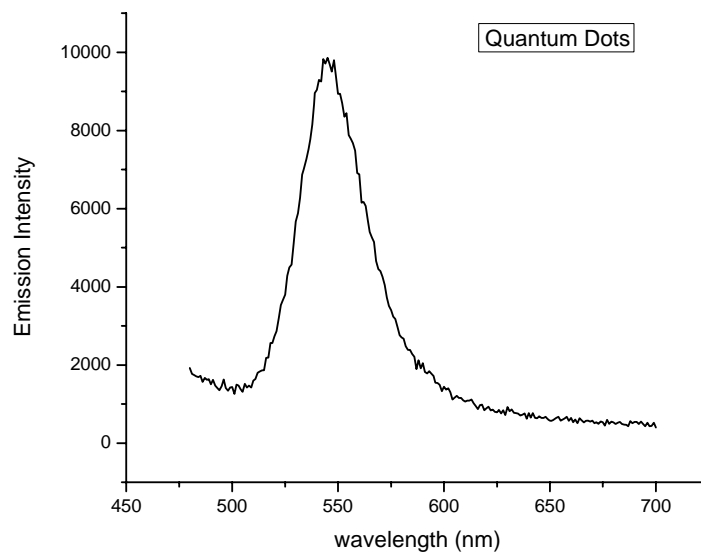

Figure 3.2 Fluorescence emission spectra of the TOPO coated CdSe/ZnS QDs. CdSe/ZnS in Chloroform is excited 445nm and fluorescence emission spectra recorded from 450nm to 700nm.

The Luminescent CdSe/ZnS QDs used for the experiments were synthesized through the approaches developed by Peng and coworkers with minor modifications. The photoluminescence (PL) spectrum of the CdSe/ZnS QDs is shown in Fig 2.2. The emission wavelength is ~ 550 nm at excitation wavelength of 445nm. The full width at half – maximum (fwhm) of the synthesized QDs is 40 ± 2 nm, which is only slightly higher than the one indicated in previous literature reports (25-35 nm)⁶⁸.

3.2 FRET between QDs and Rhodamine

The FRET system between CdSe/ZnS QDs and Rhodamine was constructed. The results from repeated experiments (Fig 3.3) fit those obtained previous in our lab. When excited at 445 nm the emission spectrum of the Rhodamine labeled QDs show two clearly separated emission peaks of the QDs and the Rhodamine molecules at 545 nm and 587 nm respectively. The emission peak of the QDs decreases with increasing Rhodamine concentration indicating the FRET between the QDs and the Rhodamine molecules occurs.

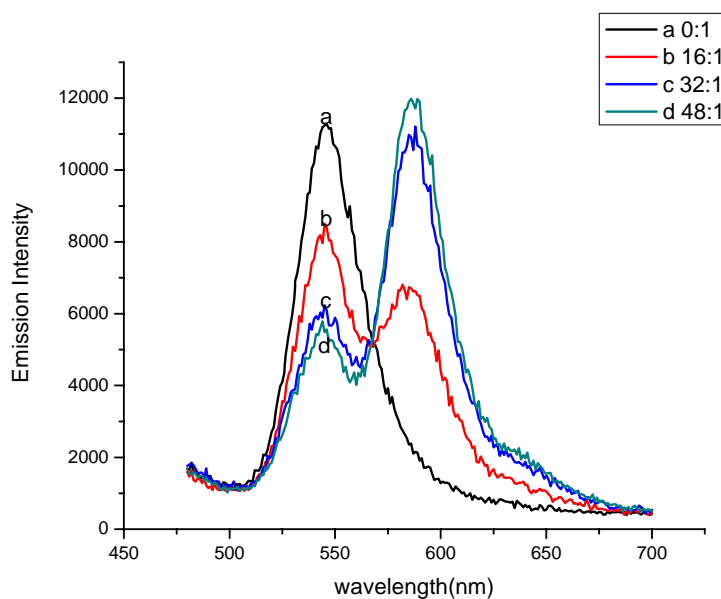

Figure 3.3 Fluorescence emission spectra of QDs donor and the corresponding Rhodamine dye acceptor in QDs- peptide-Rhodamine conjugates as a function of increasing dye to QDs ratio. The excitation wavelength is 445nm and fluorescence emission spectra are recorded from 450nm to 700nm.

3.3 Synthesis of Water – Soluble QDs

3.3.1 Direct attachment of protein/peptides to QD surface

Previously Weiss and co-workers⁶⁹ demonstrated the direct attachment of peptides to the QDs surface using phytochelatins – related peptides to cap CdSe/ZnS core/shell QDs based on the naturally formed organic – inorganic hybrid materials. It not only provided surface passivation and water solubility, but also a point of biochemical modification. In our lab, the simple peptide was used to coat QDs directly. In this study, we used the tetra peptide RGDC to coat CdSe/ZnS QDs. To avoid aggregation of QDs during the coating reaction, 9:1 (V/ V) pyridine/DMSO was used as cosolvent to dissolve both peptides and the TOPO – coated QDs. Since tetramethylammonium hydroxide (TAMOH) has previously been shown to remove TOPO effectively from the surface of CdSe/ZnS QDs, the binding of the peptides on the ZnS layer was triggered by forming cysteine thiolates anions with addition of TAMOH base. Upon binding of the peptide, the QDs precipitated out of the cosolvent, and could be redissolved in water. The excess of unbound peptide was then removed by dialysis using an amicon centricon spin dialysis tube with a cutoff molecular weight of 30kDa.

The direct attachment of peptide to molecules of QDs is quick as ~ 1 hour. It can enable linking the QDs to Rhodamine molecules and facilitate FRET interaction between them. The emission spectra (figure 3.5) proved the occurrence of FRET between QDs and Rhodamine. The Digital fluorescence microscopy images were also used to provide visual evidence of FRET between the QDs and Rhodamine. As shown in Figure 3.6 and 3.7, the emission color of peptide coated QDs is green (figure 3.6) and the emission color turns yellow when Rhodamine is bound

to the peptide coated QDs (figure 3.7). This emission color indicates the occurrence of FRET between QDs and the bound Rhodamine molecule.

Since the peptide RGDC has a polar but positively charged domain containing arginine residue (R), this amino acid was used to provide the sites for enzymatic cleavage; the QDs readily aggregated upon water solubilization. These aggregations could be due to the interaction of the positively charged arginine residues with the negatively charged surface of the QDs, the problem of aggregation is severe.

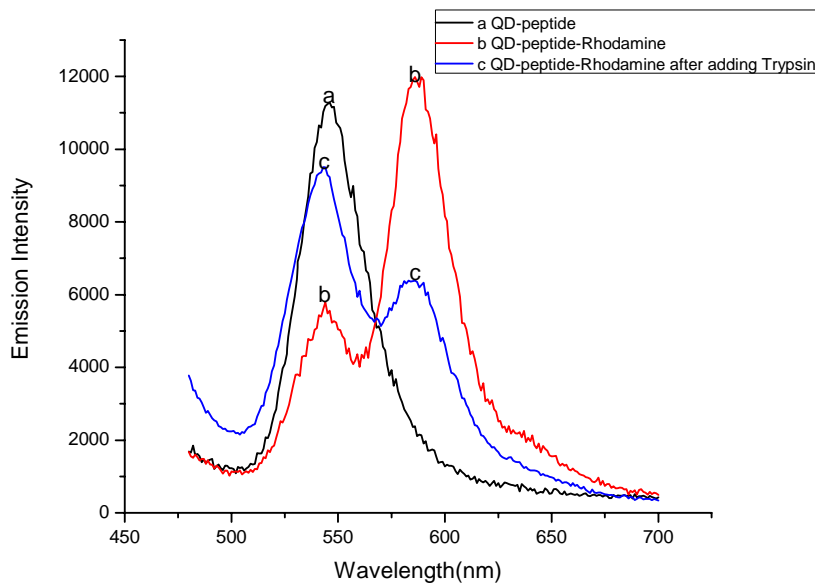

Figure 3.4 Emission spectra of (a) QD – peptide; (b) QD-peptide-Rhodamine; (c) QD – peptide-Rhodamine after adding trypsin at excitation wavelength of 445 nm. Here 150 μ l of 0.1 μ M peptide coated QDs , 150 μ l of 4.8 μ M Rhodamine Red-X, succinimidyl ester with PBS 7.4 buffer and 500ul of 1mg/ml trypsin in total 1ml solution.

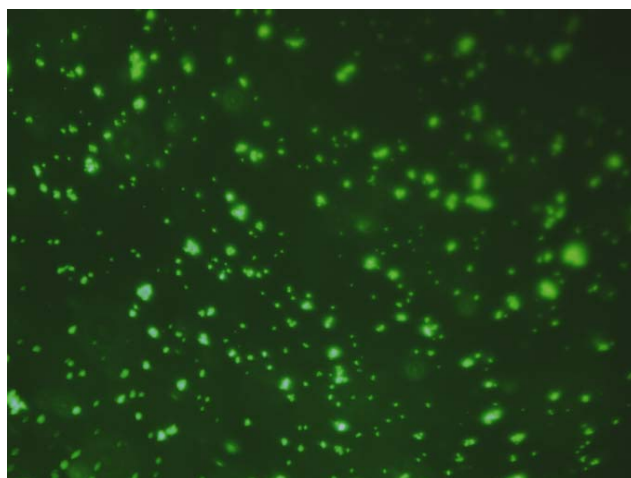

Figure.3.5 Digital fluorescence image of QD-peptide by direct attachment of peptide RGDC to QD surface. The image was taken through an excitation filter: $\lambda_{ex}=450$ nm, a dichroic mirror: 505nm; an emission filter: $\lambda_{em}>515$ nm; objective: 20X with NA= 0.9.

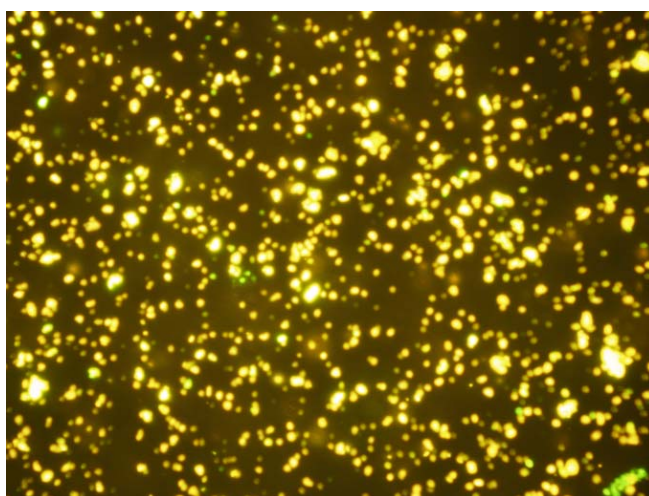

Figure 3.6 Digital fluorescence microscope images of Rhodamine – peptide – QD ($\lambda_{ex}=460 \pm 10$ nm, $\lambda_{em}>515$ nm)with 20X microscope objective by direct attachment of peptide RGDC to QD surface.

3.3.2 QD-Mercaptoacetic Acid

The surface of TOPO coated CdSe/ZnS QDs is hydrophobic; therefore they are not directly soluble in aqueous solution. Exchanging the hydrophobic TOPO surfactant molecules with bifunctional molecules is the simplest way to obtain a hydrophilic surface. In this way, TOPO capped CdSe/ ZnS nanocrystals can be transferred into aqueous solution by exchanging the TOPO on their surface with a layer of a mercaptocarboxylic acid with thiols (–SH) group as ZnS-binding groups and carboxyl (–COOH) groups as hydrophilic groups (Fig. 3.7). Since Carboxyl groups on the surface of QDs are negatively charged at neutral pH, QDs capped with carboxyl groups repel each other electrostatically, which prevents aggregation. However in electrolyte solutions at salt concentrations of a few hundred millimolar, the particles will precipitate due to Columbic interactions.

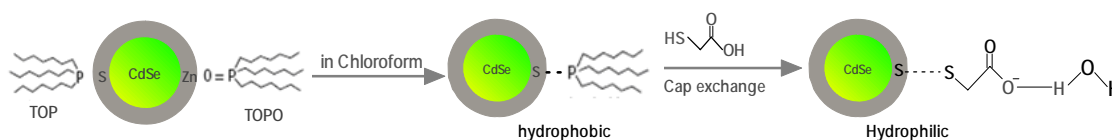

Figure 3.7 Schematic of synthesis of QD-mercaptopropionic acids

Based on the work of Nie²⁹, who developed the method 'cap exchange' to produce high aqueous soluble QDs, suitable for biological applications. The mercaptopropionic acid was used as a bifunctional capping ligand in my study. The mercapto group in mercaptopropionic acid binds to the Zn atom when reacting with CdSe/ZnS QDs and the polar carboxylic acid group renders the QDs water – soluble, with the free carboxylic acid can covalently couple to various biomolecules by cross – linking to reactive amine groups.

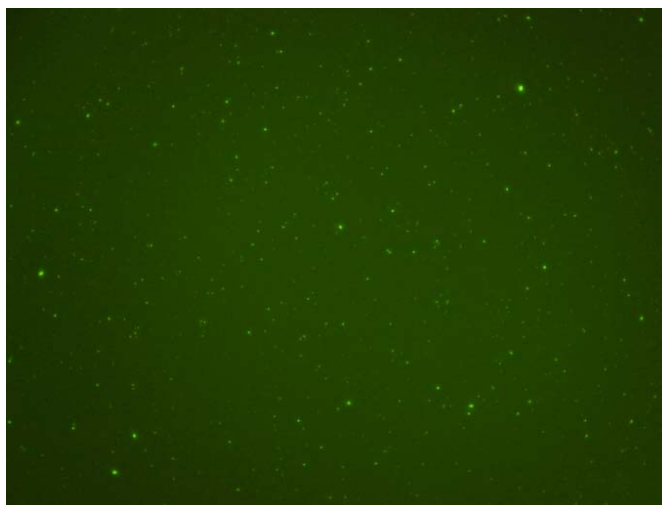

Figure 3.8 Digital fluorescence microscope images of QD-mercaptopropionic acid ($\lambda_{ex}=450\text{nm}$, $\lambda_{em}>515\text{nm}$) in PBS 7.4 buffer with 20X microscope objective

After the mercaptopropionic acid coated QDs disperse in aqueous solution, the solution appears clear under room light. A color luminescence image of QD with mercaptopropionic acid layer is shown in Fig 3.8. It indicates that the solubilization steps did not result in a high degree of aggregation. Optical measurement showed that the emission spectra in Fig 3.8 are similar for the QDs in chloroform and the water – soluble QDs, which demonstrate the optical properties of QDs remain nearly unchanged after solubilization (Fig 3.9). The numbers of mercaptopropionic acid per QD have not been determined experimentally.

Unfortunately, the mercaptopropionic acid capped QDs were only stable in aqueous buffer for up to one month, after which the QDs precipitated out of solution. The reason for this problem is because the thiol–ZnS bonds are dynamic, which means that the thiol ligands bind and unbind in a dynamic equilibrium; however, as soon as these nanocrystals are dialyzed against pure buffer or water over a longer period, they start to precipitate since all free thiol ligands have

disappeared. Therefore the thiol–ZnS bonds are not stable enough to endure a long time, which limits the water solubility of CdSe/ZnS QDs capped with mercaptocarboxylic acids. Enhanced stability can be achieved by using mercaptocarboxylic acids with two instead of just one thiol group⁴⁴.

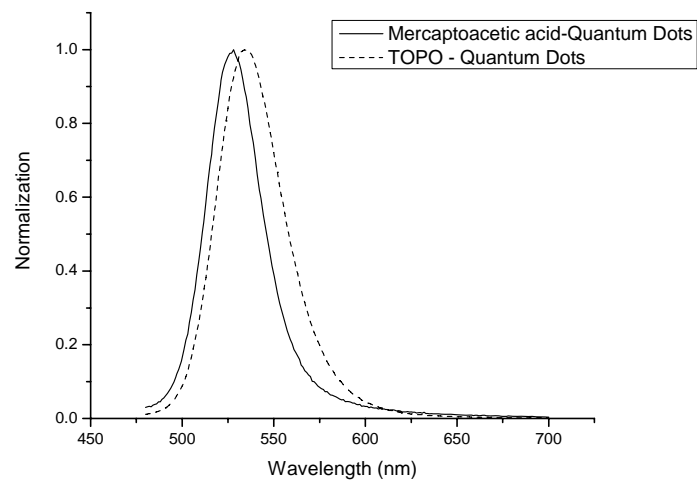

Figure 3.9 Fluorescence emission spectra of the QD before (dash line) and after modification of mercaptoacetic acid (solid line) at excitation wavelength of 445 nm

3.3.3 Co-coupling Peptide and PEG on QDs

In section 3.3.1, the large number of positive residues in the coating peptide molecules may have caused aggregation by “bridging” negatively charged QDs. The aggregation problem can be overcome by changing peptide RGDC with net positive charge into peptide AGSE with net negative charge and by co-coupling peptides and PEG (fig 3.10), a polymer known to minimize molecular interactions and improve solubilities⁵⁷.

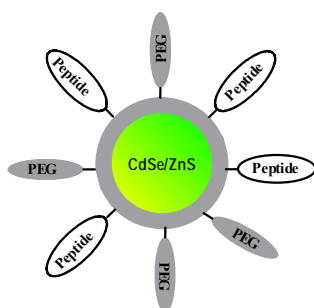
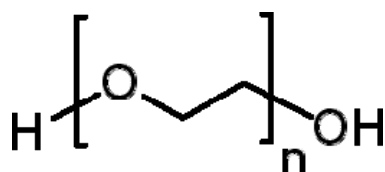

Figure 3.10 Schematic representations of peptide-coated QDs with PEG

For many years polyethylene glycol (PEG) has been a molecule of interest to the biomedical researchers. PEG is a linear neutral polymer available in a variety of molecular weights. It is made from the anionic polymerization of ethylene oxide which depending on the polymerization conditions forms polymer strands of various lengths. These molecules are soluble in water and most organic solvents. The two hydroxyl groups located at each end of the polymer enable it's coupling to peptides, drugs and other biomaterials. PEG coupled to other molecules can alter the solubility characteristics of the molecules they are coupled with. This polymer is nontoxic and not harmful to the bioactivity of proteins or cells⁷⁰. PEG has been also used to increase the

solubility of formally insoluble drugs and decrease the toxicity of others. PEG has been utilized in many research groups as a stabilizer of nanoparticles in aqueous solution.

In my study, The PEG functionalized with Maleimide (Fig 3.11), which can coat PEG to QDs by coupling maleimide of PEG with thiol groups of QDs was obtained from Nektar. As with any of thiol PEGylation reagents, use of this PEG-thiol reagent allows thiol-specific PEGylation of free thiols forming a disulfide-bridged polymer conjugate to the cysteine side chain of proteins and peptides⁷¹. This reagent is also useful for thiol groups present in other types of active agents and small molecules.



(a)

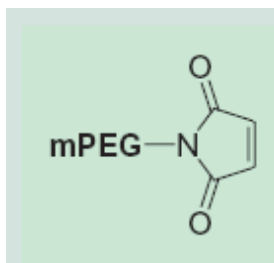

(b)

Fig 3.11 Molecular structure of PEG(a) and mPEG-MAL (b)

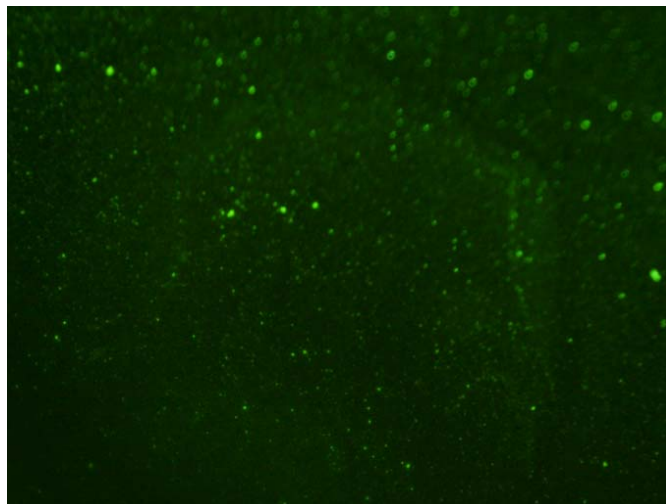

Figure 3.12 Digital fluorescence microscope images of QD-PEG ($\lambda_{ex}=450\text{nm}$, $\lambda_{em}>515\text{nm}$) in 10mM PBS 7.4 buffer with 20X microscope objective

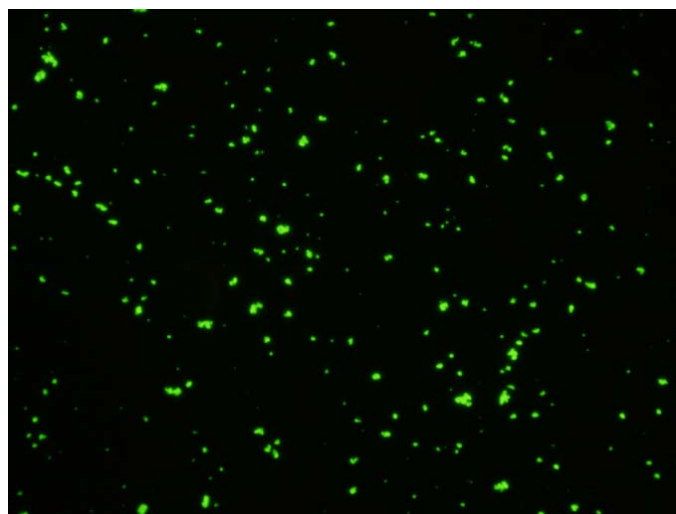

Figure 3.13 Digital fluorescence microscope images of QD after co-coupling of peptide AGSE and PEG ($\lambda_{ex}=450\text{nm}$, $\lambda_{em}>515\text{nm}$) in 10mM PBS 7.4 buffer with 20X microscope objective

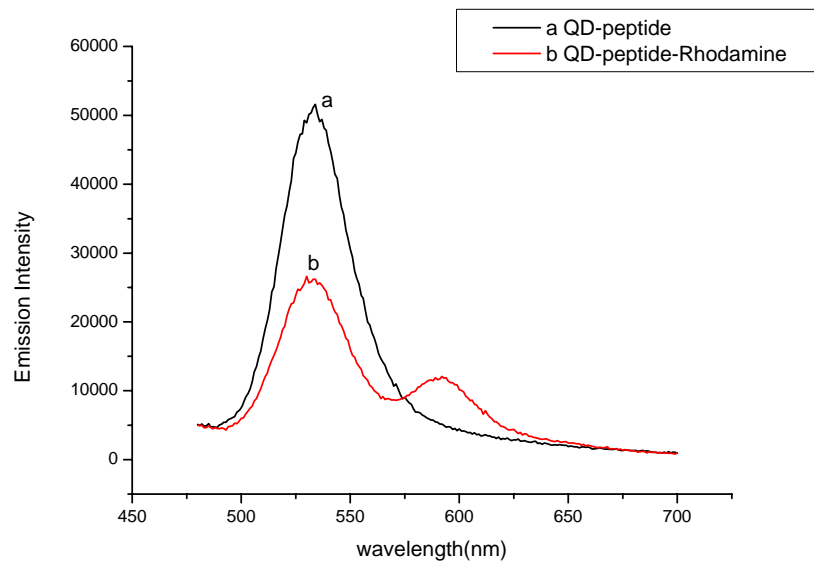
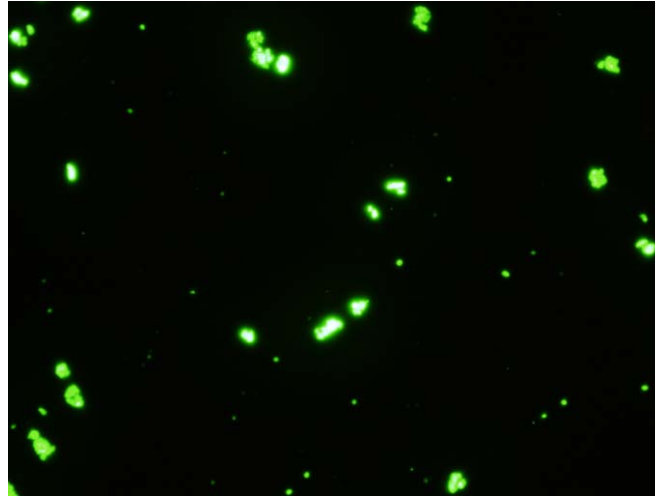
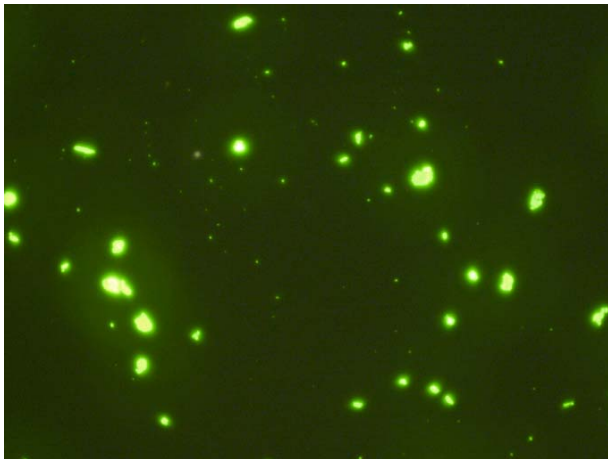

Figure 3.14 Emission spectra of (a) QD after co-coupling peptide AGSE and PEG and (b) FRET between QD – peptide (PEG) and Rhodamine at excitation wavelength of 445 nm.



(a)



(b)

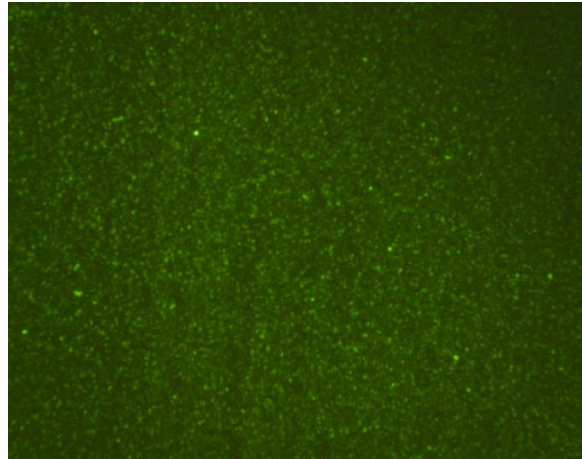

(c)

Figure 3.15 Digital fluorescence microscope images of QD with 20X microscope objective after co-coupling of peptide AGSE and PEG at (a) 100 mM, (b) 50mM and (c) 1.5 mM EDAC

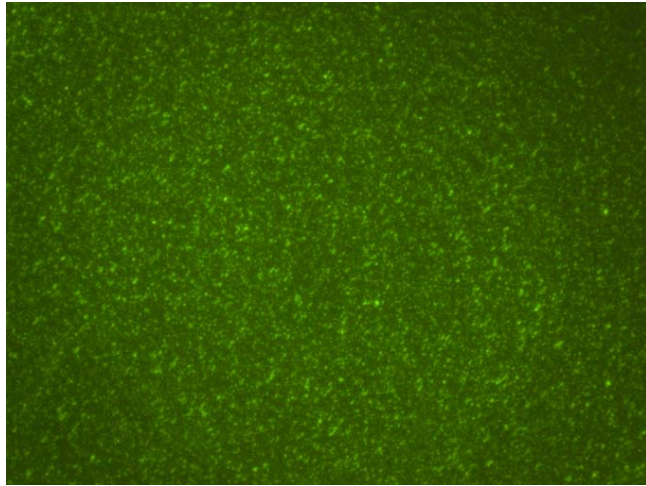

(a)

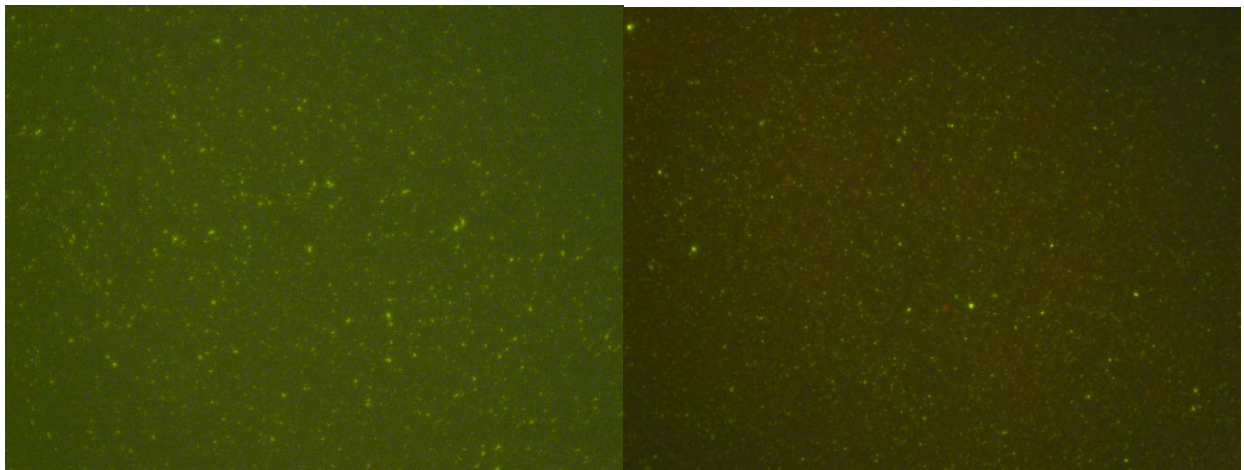

(b)

(c)

Figure 3.16 Digital fluorescence microscope images with 20X microscope objective of (a) peptide AGSE (PEG) coated QDs; (b) Rhodamine-labeled peptide AGSE (PEG) coated QDs at 100ul 4.8 μ M Rhodamine and (c) (b) Rhodamine-labeled peptide AGSE (PEG) coated QDs at 4.8 μ M 200ul Rhodamine.

The presence of both carboxylates and amines on one of the molecules to be conjugated with EDAC may also result in self – polymerization, because the substance can then react with

another molecule of its own kind instead of the desired target⁷². In this case, when using EDAC to conjugate peptide AGSE to mercaptoacetic acid on the surface of QDs, the peptide contains a carboxylate and an amine. The result typically is peptide polymerization and aggregation of QDs. Therefore, the test of proper quantity of EDAC should be done to find the ratio of EDAC to Peptide AGSE – QDs without precipitation.

Based on the reasons mentioned above, control of quantity of EDAC was implemented. Different concentrations of EDAC for maintaining the stability of QD-peptide AGSE (PEG) conjugate from 100 mM to 1.5 mM were tested until a soluble conjugate is obtained. As shown in the color luminescence images in Fig 3.15, when scales back the concentration of addition of EDAC to 1.5 mM, the problem of precipitation was alleviated significantly.

After purifying the conjugate by spin dialysis, the Rhodamine, conjugating to peptide AGSE on the surface of QDs, was added into the conjugate solution. From the results of the color images in Fig 3.16, the emission color of the peptide coated QDs is green (figure 3.16a). The emission color turns yellow when Rhodamine is bound to the peptide coated QDs (figure 3.16b and 3.16c). This emission color indicates the FRET between QDs and the bound Rhodamine molecule occurs.

3.4 Effect of pH on FRET Using Enzymatic Assay

3.4.1 Effect of PH to the FRET system

The objective of the experiments described in this section was to determine the effect of pH on the FRET efficiency in the QDs – peptide – Rhodamine system. The emission spectra in Fig 3.17 show the emission intensities of QDs and Rhodamine in FRET system at 545nm and 587 nm respectively. The results of indicate that the emission intensities of QDs decreased by ~ 50% upon changing the pH 4.0 to pH 9.0. This is important because it demonstrates that pH can affect the FRET system between QDs and Rhodamine.

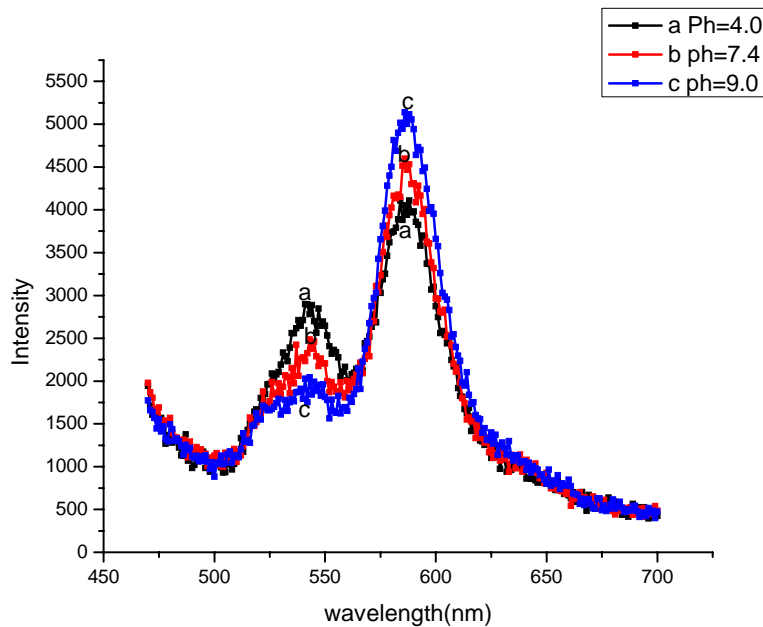

Fig.3.17 Emission Spectra of FRET between QDs and Rhodamin at pH 4.0(a), 7.4(b) and 9.0(c) at excitation wavelength of 445 nm. 150 μ l of 0.1 μ M peptide coated QDs and 150 μ l of 4.6 μ M Rhodamine

Red-X, succinimidyl ester in buffer.

3.4.2 Effect of pH on Enzymatic Activity in QDs-peptide-Rhodamine FRET System

In our lab, FRET-based enzymatic activity probe was prepared in PBS Buffer 7.4 solution containing Rhodamine:QDs at a ratio of 48:1. The tetra-peptide RGDC was used to link between the QDs and the Rhodamine molecules. The QDs FRET-based enzymatic probes were first used to determine the activity of trypsin. Trypsin is a digestive enzyme that cleaves peptides on the C-terminal side of lysine (K) or arginine (R). tryptic would cleave RGDC peptide to release Rhodamine molecules to the solution, which would in turn affect the FRET signal of the QDs. In the RGDC particular peptide used in this study the cleavage site was after Arginine (R).

Enzymes are sensitive to pH and have a specific range of activity. All have an optimum pH. The pH can stop enzyme activity by denaturing the three dimensional shape of the enzyme by breaking weak bonds such as ionic, and hydrogen bonds. The Optimum pH range of trypsin is pH 8-9. Here the enzymatic activities based on QDs-peptide-Rhodamine FRET system at different environments were demonstrated. The emission spectra in fig 3.18 show the effect of trypsin on the FRET signal of the Rhodamine-labeled peptide-coated QDs in phosphate buffer solution at pH 5.6, 7.4 and 8.7 ($\lambda_{ex} = 445\text{nm}$). An increase in the QDs emission peak at 545 nm and a decrease in the Rhodamine emission peak at 587 nm are clearly seen, which is attributed to the enzymatic cleavage of the peptide molecules which leads to the expected release of Rhodamine molecules from the QDs. It also indicates the optimum pH condition for the enzymatic activity in QDs-peptide-Rhodamine FRET system is ~ 9.0 as expected.

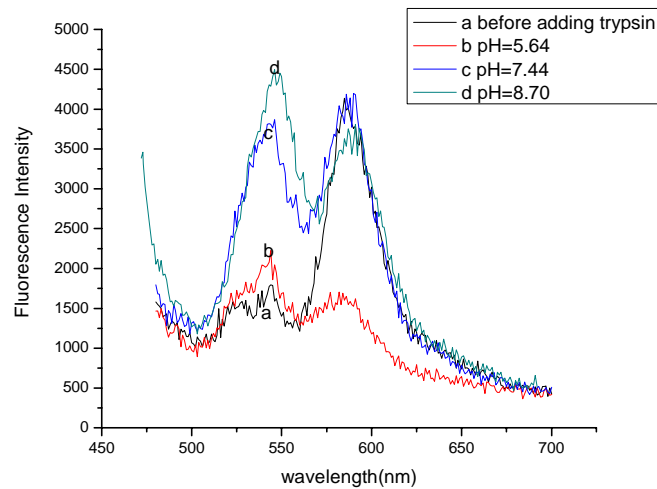

Fig 3.18 Fluorescence emission spectra of FRET signal of the Rhodamine-labeled peptide-coated QDs at pH 5.64 (b), 7.44(c) and 8.70(c) with and without trypsin(a); 150 μ l of 0.1 μ M peptide coated QDs and 150 μ l of 4.8 μ M Rhodamine Red-X, succinimidyl ester in buffer.

Time dependent measurements of the FRET signal of the QDs at pH 5.6, 7.4 and 8.7 were carried out to provide the dynamic information for the enzymatic activity over long observation times. Fig 3.19 shows the temporal dependence of the ratio F_d/F_0 of the QDs in phosphate buffer solution at different pH. F_d is the emission peak of the QDs at 545 nm (donor) and F_0 is the emission peak of the QDs at 587 nm before adding trypsin. The black square, red round, and blue triangle plots are the ratio F_d/F_0 of the QDs with time at pH 5.64, 7.4 and 8.7 respectively, which indicates the enzymatic activity of trypsin to the system of FRET system over the time of 600 second. It can be seen that the ratio F_d/F_0 increased with time in phosphate buffer solution at from pH 5.6 to pH 8.7 and then reached a platform, which indicates trypsin was approaching the maximal ability of inhibition to FRET system. It was also proved the optimum pH for trypsin in this FRET system is pH \sim 9.0 over time, which fits the results expected. Compared to the old

FRET system, which is performed in PBS 7.4 solution, the system in optimum pH 9.0 for trypsin can make it affect the FRET system more efficiently.

In these experiments the emission intensity of the QDs at 545 nm and Rhodamine at 587 nm were constantly measured following the addition of trypsin to Rhodamine- labeled peptide-coated QDs.

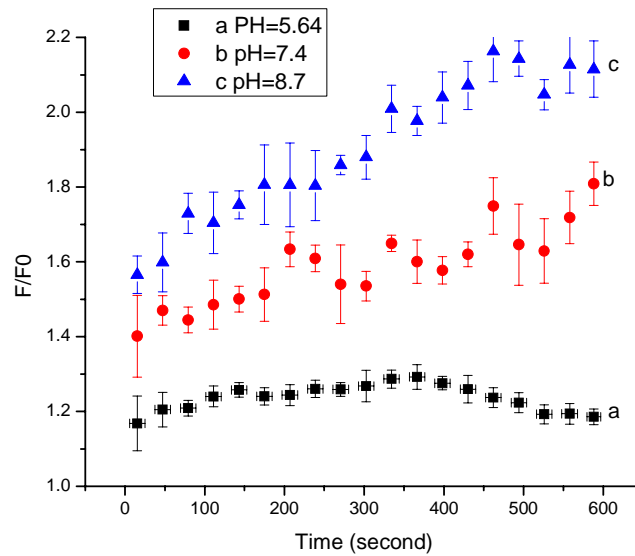

Figure 3.19 Temporal dependence of the ratio F_d/F_0 of the QDs at pH 5.6(a), 7.4 (b) and 8.7(c) at excitation wavelength of 445 nm. F_d is the emission peak of the QDs at 545 nm (donor) and F_0 is the emission peak of the QDs at 587 nm before adding trypsin.

CHAPTER 4 SUMMARY

Fluorescence resonance energy transfer (FRET) is one of a few techniques to measure nanometer scale distance and changes in distance based on distance – dependent transfer of energy from a donor fluorophore to an acceptor fluorophore. FRET has been recently used in biological applications to monitor intracellular interactions and binding events.

Luminescent Quantum Dots (QDs) intrigue the interest of researchers with their properties of high quantum yield, high molar extinction coefficient, and broad absorption and narrow emission spectra. In our laboratory we showed that CdSe/ZnS quantum dots are a visible alternative to organic fluorophores in FRET systems. The spectral tunability of QDs improve the spectral overlap with an acceptor fluorophore. However, since prepared in organic solvents, QDs are not suitable for biological systems. To make QDs with hydrophobic capping ligands to be water – soluble, various strategies of the surface functionalization with hydrophilic ligands has been developed in recent years. These strategies are realized primarily by ‘cap exchange’ or encapsulation.

The ‘cap exchange’ is a process to replace the TOP/TOPO with bifunctional ligands with one end binding to the surface of QDs (for example, thiol) and one hydrophilic end group. Typically, the group binding to surface is thiol group and hydrophilic group is hydroxyl or carboxyl group. This method is simple but is not stable due to the dynamic thiol – ZnS interactions. Although dithiol dihydrolipoic acid ligands can improve the stability, almost all carboxyl – terminated ligands limit dispersion to basic pHs. In encapsulation methods the TOP/TOPO capped QDs are

encapsulated in a heterofunctional polymer coating. The polymer/phospholipids encapsulation can work over a broader pH range. However since silica shells tend to increase the diameter of CdSe-ZnS from ~ 4-8 nm to ~ 20-30nm, a size that may preclude fluorescence resonance energy transfer (FRET)-based investigation. Therefore, 'cap exchange' is the predominant method to prepare water-soluble QDs in FRET – based biological application.

In my study, several methods of “cap exchange” were tested to enable forming QDs with minimal aggregation. The QD-mercaptoacetic acid is simple to synthesize and has good water-solubility, but the QDs samples are not stable and easily aggregate after one month in storage. The direct attachment of peptide molecules to the QDs passivate the surface, enable water solubility of QDs, and provide a point to biochemical modification. It is only applicable for phytochelatin – related peptides, not for all kind of peptides universally; otherwise, the problem of aggregation will happen like that in my study with the peptide RGDC.

The large number of positive residues in the peptide molecules may cause aggregation by “bridging” negatively charged QDs. In this study we show that the aggregation problem can be overcome by co-coupling peptides and PEG to the QDs. The surfactant-assisted QD-peptide, such as Co-coupling net negative charge AGSE and PEG on QDs, has good water –solubility when control the quantity of PEG and coupling agent EDAC are properly controlled.

In the future, further study in this area will focus on optimizing the molecular weight of PEG, the ration between peptide and PEG attached to the surface of QDs, functionalization of PEG will be optimized.

In applying the QDs in biological system, our lab has developed a new QDs based FRET probes, in which FRET occurs in a Rhodamin – peptide – QDs system. Since the enzyme trypsin is specifically cleave the peptide RGDC between Lysine and Arginine residues. It is possible to use the FRET system to measure trypsin activity and other digestive enzymes.

Enzymes are sensitive to pH and have specific range of activity. All have an optimum pH. The pH can stop enzyme activity by denaturing the three dimensional shape of the enzyme by breaking weak bonds such as ionic, and hydrogen. For typsin the optimum pH for enzymatic activity is 8-9.

In this study, we tested the effect of pH on FRET system and typsin ability to inhibit in FRET between the QDs and Rhodamine. Based on the FRET system using method of direct attachment of protein/peptides to QDs surface, the experiments of the effect of pH on FRET were performed. We tested the effect of pH 4.0, 7.4 and pH 9.0. The results of emission spectra shown indicate pH doesn't affect significantly the emission intensities of QDs and Rhodamine in FRET system at 545nm and 587 nm respectively. This is important because it provides a system that is not sensitive to pH.

The enzymatic activities based on QDs-peptide-Rhodamine FRET system at different environments was demonstrated. The results show that pH affect the enzymatic activity more significantly. An increase in the QDs emission peak at 545 nm and a decrease in the Rhodamine emission peak at 587 nm is clearly seen, which is attributed to the enzymatic cleavage of the peptide molecules which leads to the expected release of Rhodamine molecules from the QDs. Both emission spectra and time dependent measurements indicate that the optimum pH for the trypsin ability of inhibition in this FRET system is pH ~ 9.0, which fits the results expected.

For the effect of pH to the enzymatic activity of the QDs based FRET probe, the mechanism of it can be studied in detail in the future to help understand fully this quantum dots based FRET system. The inhibitor of trypsin can be used to test the effect of inhibitor of trypsin on the enzymatic activity in QDs FRET system, which can be used in biological system if well explored.

REFERENCES

1. Michalet, X.; Pinaud, F.F.; Bentolila, L.A.; Tsay, J.M.; Doose, S.; Li, J.J.; Undaresan G.; Wu, A.M.; Gambhir, S.S.; Weiss, S. *Science*. **2005**, 307, 538-544.
2. Medinz, I.; Uyeda, H. T.; Goldman, E. R.; Mattoussi, H. *Nature Materials* **2005**, 4, 435-446.
3. Lakowicz, J.R. *Principles of Fluorescence Spectroscopy*, Plenum Press, New York, **1999**, 4-6.
4. Haugland, R. P. *Handbook of Fluorescent Probes and Research Products*, Ninth Edition, **2002**, 25-26.
5. Blagoi, G.; Rosenzweig, N.; Rosenzweig, Z. *Anal. Chem.* **2005**, 77, 393-399.
6. Schleifenbaum, A.; Stier, G.; Gasch, A.; Sattler, M.; Schultz, C. *J. Am. Chem. Soc.* **2004**, 126, 11786-11787.
7. Alivisatos, A. P. *Science* **1996**, 271 (5251), 933-937.
8. Murphy, C.J. *Anal. Chem.* **2002**, 74, 520A-526A.
9. Yoffe, A.D. *Adv. In Physics*, **2001**, 50, 1-208
10. Efros, A.L.; M. Rosen, M. *Ann. Rev. Mater. Sci.* **2000**, 30,475-521.
11. Murphy, C.J.; Coffey, J.L. *Appl. Spectrosc.* **2002**, 56,16A-27A.
12. Rama Krishna, M.V.; Friesner, R. A. *J. Chem. Phys.* **1991**, 95, 8309-8322.
13. Wu, X.; Liu, H.; Liu, J.; Haley, K.N.; Treadway, J.A.; Larson, J. P.; Ge, N.; Peale, F.; Bruchez, M. P. *Nature Biotechnology* **2003**, 21, 41-46.
14. Jaiswal, J.K.; Mattoussi, H.; Mauro, J.M.; Simon, S.M. *Nature Biotechnology* **2003**, 21, 47-51.
15. Gaponik, N.; Talapin, D. V.; Rogach, A. L.; Eychmuller, A.; Weller, H. *Nano Lett.* **2002**, 2, 803-806.
16. Hirai, T.; Watanabe, T.; Komasaawa, I. *J. Phys. Chem. B.* **1999**, 103, 10120-10126.
17. Farmer, S. C.; Patten, T. E. *Chem. Mater.* **2001**, 13, 3920-3926.

18. Mansur, H.S.; Vasconcelos, W.L.; Grieser, F.; Caruso, F. *J. Mater. Sci.* **1999**, 34, 5285-5291.
19. Zelner, M.; Minti, H.; Reisfeld, R.; Cohen, H.; Tenne, R. *Chem. Mater.* **1997**, 9, 2541-2543.
20. Murray, C. B.; Norris, D. J.; Bawendi, M. G. *J. Am. Chem. Soc.* **1993**, 115, 8706-8715.
21. Peng, Z. A.; Peng, X. *J. Am. Chem. Soc.* **2001**, 123, 183-187.
22. Peng, Z. A.; Peng, X. *J. Am. Chem. Soc.* **2001**, 123, 1389-1395.
23. Yu, W. W.; Qu, L.; Guo, W.; Peng, X. *Chem. Mater.* **2003**, 15, 2854-2860.
24. Nirmal, M.; Dabbousi, B.O.; Bawendi, M.G.; Macklin, J.J.; Trautman, J.K.; Harris T.D.; Brus, L.E. *Nature* **1996**, **383**, 802-804.
25. Hines, M. A.; Guyot-Sionnest, P. *J. Phys. Chem.* **1996**, 100, 468-471.
26. Dabbousi, B. O.; Rodriguez-Viejo, J.; Mikulec, F. V.; Heine, J. R.; Mattoussi, H.; Ober, R.; Jensen, K. F.; Bawendi, M. G. *J. Phys. Chem. B* **1997**, 101, 9463-9575.
27. Li, J. J.; Wang, Y. A.; Guo, W.; Keay, J. C.; Mishima, T. D.; Johnson, M. B.; Peng, X. *J. Am. Chem. Soc.* **2003**, 125, 12567-12575.
28. Mekis, I.; Talapin, D. V.; Kornowski, A.; Haase, M.; Weller, H. *J. Phys. Chem. B* **2003**, 107, 7454-7464.
29. Malik, M. A.; O'Brien, P.; Revaprasadu, N. *Chem. Mater.* **2002**, 14, 2040-2010.
30. Chan, W.; Nie, S. *Science* **1998**, 281, 2016-2018.
31. Mattoussi, H.; Mauro, J. M.; Goldman, E. R.; Anderson, G. P.; Sundar, V. C.; Mikulec, F. V.; Bawendi, M. G. *J. Am. Chem. Soc.* **2000**, **122**, 12142-12150.
32. Mitchell, G. P.; Mirkin, C. A.; Letsinger, R. L. *J. Am. Chem. Soc.* **1999**, 121, 8122-8123.
33. Goldman, E. R.; Balighian, E. D.; Mattoussi, H.; Kuno, M. K.; Mauro, J. M.; Tran, P. T.; Anderson, G. P. *J. Am. Chem. Soc.* **2002**, 124, 6378-6382.
34. Uyeda, H. T.; Medintz, I. L.; Jaiswal, J. K.; Simon, S. M.; Mattoussi, H. *J. Am. Chem. Soc.* **2005**, 127, 3870-3878.
35. Bruchez, M.; Jr, Moronne, M.; Gin, P.; Weiss, S.; Alivisatos, A. P. *Science* **1998**, 281, 2013-2016.
36. Gerion, D.; Pinaud, F.; Williams, S. C.; Parak, W. J.; Zanchet, D.; Weiss, S.; Alivisatos, A. P. *J. Phys. Chem. B* **2001**, 105, 8861-8871.

37. Dubertret, B.; Skourides, P.; Norris D. J.; Noireaux, V.; Brivanlou A. H.; Libchaber, A. *Science* **2002**, 298, 1759-1762.
38. Wu, X.; Liu, H.; Liu, J.; Haley, K. N.; Treadway, J. A.; Larson, J. P.; Ge, N.; Peale, F.; Bruchez, M. P. *Nature Biotechnol.* **2003**, 21, 41-46.
39. Pellegrino, T.; Manna, L.; Kudera, S.; Liedl, T.; Koktysh, D.; Rogach, A. L.; Keller, S.; Ralder, J.; Natile, G.; Parak, W. J. *Nano Lett.* **2004**, 4, 703-707.
40. Osaki, F., Kanamori, T., Sando, S., Sera, T.; Aoyama, Y. *J. Am. Chem. Soc.* **2004**, 126, 6520-6521.
41. Mattheakis L. C.; Dias, J. M.; Choi, Y.; Gong, J.; Bruchez, M. P.; Liu, J.; Wang, E. *Anal. Biochem.* **2004**, 327, 200-208.
42. Ballou, B.; Lagerholm, B. C.; Ernst, L. A.; Bruchez, M. P.; Waggoner, A. S. *Bioconj. Chem.* **2004**, 15, 79-86.
43. Gao, X. ; Cui, Y. ; Levenson, R. M. ; Chung, L. W. K. ; Nie, S. *Nature Biotechnol.* **2004**, 22, 969-976.
44. Parak, W. J.; Gerion, D.; Pellegrino, T.; Zanchet, D.; Micheel, C.; Williams, S. C.; Boudreau, R.; Gros, M. A. L.; Larabell, C. A.; Alivisatos, A. Paul. *Nanotec*, **2003**, 14, R15- R27.
45. Mattoussi, H.; Mauro, J. M.; Goldman, E. R.; Anderson, G. P.; Sundar, V. C.; Mikulec, F. V.; Bawendi, M. G. *J. Am. Chem. Soc.* **2000**, 122, 12142-12150.
46. Pathak, S.; Choi, S. K.; Arnheim, N.; Thompson, M. E. *J. Am. Chem. Soc.* **2001**, 123, 4103-4104.
47. Chen, Y.; Rosenzweig, Z. *Anal. Chem.* **2002**, 74, 5132-5138.
48. Pinaud, F.; King, D.; Moore, H.P.; Weiss, S. *J. Am. Chem. Soc.* **2004**, 126, 6115-6125.
49. Goldman, E. R.; Anderson, G. P.; Tran, P. T.; Mattoussi, H.; Charles, P.T.; Mauro, J. M. *Anal. Chem.* **2002**, 74, 841-847.
50. Alivisatos, A. P. *Nature Biotechnol.* **2004**, 22, 47-52.
51. Tokumasu, F., Dvorak, J., *J. Microsc.* **2003**, 211, 256-261.
52. Pathak, S.; Choi, S.K.; Arnheim, N.; Thompson, M. E. *J. Am. Chem. Soc.* **2001**, 123, 4103-4104.
53. Xiao, Y.; Barker, P. E. *Nucleic Acids Res.* **2004**, 32, 28E.

54. Winter, J. O.; Liu, T. Y.; Korgel, B. A.; Schmidt, C. E. *Adv.Mater.* **2001**,13,1673-1677.
55. Derfus, A. M.; Chan, W.; Bhatia, S. N. *Nano Lett.* **2004**, 4, 11-18.
56. Rosenthal, S. J.; Tomlinson, I.; Adkins, E. M.; Schroeter, S.; Adams, S.; Swafford, L.; McBride, J.; Wang, Y.; DeFelice, L. J.; Blakely, R. D. *J. Am. Chem. Soc.* **2002**, 124, 4586-4594.
57. Akerman, M. E.; Chan, W.; Laakkonen, P. ; Bhatia, S. N.; Ruoslahti, E. *Proc. Nat'l Acad. Sci. USA.* **2002**, 99,12617-12621.
58. Kim, S.; Lim, Y.T.; Soltesz, E.G.; De, Grand A.M.; Lee, J.; Nakayama, A.; Parker, J.A.; Mihaljevic, T.; Laurence, R.G.; Dor, D.M.; Cohn, L.H.; Bawendi, M.G.; Frangioni, J.V. *Nat Biotechnol.* **2004**, 22, 93-97.
59. Willard, D. M.; Carillo, L. L.; Jung, J.; Van Orden, A. *Nano Lett.* **2001**, 1, 469-474.
60. Tran, P.T.; Goldman, E.R.; Anderson, G.P.; Mauro, J.M.; Mattoussi, H. *Physica Status Solidi-B*, **2002**, 229, 427-432.
61. Patolsky, F.; Gill, R.; Weizmann, Y.; Mokari, T.; Banin, U.; Willner, I. *J. Am. Chem. Soc.* **2003**, 125, 13918-13919.
62. Medintz, I. L.; Clapp, A.R.; Mattoussi, H.; Goldman, E.R.; Fisher, B.; Mauro, J.R. *Nature Mater.* **2003**, 2, 630-638.
63. Clapp, A. R.; Medintz, I. L.; Mauro, J. M.; Fisher, B. R.; Bawendi, M. G.; Mattoussi, H. *J. Am. Chem. Soc.* **2004**, 126, 301-310.
64. Oh, E.; Hong, M.Y.; Lee, D.; Nam, S.-H.; Yoon, H. C.; Kim, H.-S. *J. Am. Chem. Soc.* **2005**, 127, 3270-3271.
65. Goldman, E. R.; Medintz, I. L.; Whitley, J. L.; Hayhurst, A.; Clapp, A. R.; Uyeda, H. T.; Deschamps, J. R.; Lassman, M. E.; Mattoussi, H. *J. Am. Chem. Soc.* **2005**, 127, 6744-6751.
66. Chang, E.; Miller, J. S.; Sun, J.; Yu, W.; Colvin, V. L.; Drezek, R.; West, J. L. *Biochemical and Biophysical Research Communication*, **2005**, 334, 1317-1321.
67. Wang, D.; He, J.; Rosenzweig, N.; Rosenzweig, Z. *Nano Lett.* **2004**, 4(3); 409-413.
68. Bruchez Jr, M.; Moronne, M.; Gin, P.; Weiss, S.; Alivisatos, A. P. *Science* **1998**, 281, 2013-2016.
69. Pinaud, F.; King, D.; Moore, H.P.; Weiss, S. *J. Am. Chem. Soc.* **2004**, 126, 6115-6125.
70. Roberts, M. J.; Bentley, M. D.; Harris, J. M. *Advanced Drug Delivery Reviews* **2002**, 54,

459-476.

71. www.Nektar.com.

72. Bioconjugate Techniques, Gerg T. Hermanson, Academic Press, **1996**, 170-173.

VITA

The author was born in Guizhou, China. She obtained her B.S. in Chemistry at Chongqing University, China in 1999 and M.S. in Physical Chemistry at Chongqing University, China in 2003. In 2004, she joined the Department of Chemistry at the University of New Orleans and became a member of Professor Zeev Rosenzweig's research group.