

Low-Cost Manufacturing of the Point Focus Concentrating Module and Its Key Component, the Fresnel Lens

Final Subcontract Report 31 January 1991 - 6 May 1991

T. Saifee and A. Konnerth III
Solar Kinetics, Inc.
Dallas, Texas

NREL technical monitor: R. Mitchell



National Renewable Energy Laboratory
(formerly the Solar Energy Research Institute)
1617 Cole Boulevard
Golden, Colorado 80401-3393
A Division of Midwest Research Institute
Operated for the U.S. Department of Energy
under Contract No. DE-AC02-83CH10093

Prepared under Subcontract No. XC-1-10057-15

November 1991

DISTRIBUTION OF THIS DOCUMENT IS UNLIMITED

MASTER

OMP

On September 16, 1991, the Solar Energy Research Institute was designated a national laboratory, and its name was changed to the National Renewable Energy Laboratory.

NOTICE

This report was prepared as an account of work sponsored by an agency of the United States government. Neither the United States government nor any agency thereof, nor any of their employees, makes any warranty, express or implied, or assumes any legal liability or responsibility for the accuracy, completeness, or usefulness of any information, apparatus, product, or process disclosed, or represents that its use would not infringe privately owned rights. Reference herein to any specific commercial product, process, or service by trade name, trademark, manufacturer, or otherwise does not necessarily constitute or imply its endorsement, recommendation, or favoring by the United States government or any agency thereof. The views and opinions of authors expressed herein do not necessarily state or reflect those of the United States government or any agency thereof.

Printed in the United States of America
Available from:
National Technical Information Service
U.S. Department of Commerce
5285 Port Royal Road
Springfield, VA 22161

Price: Microfiche A01
Printed Copy A05

Codes are used for pricing all publications. The code is determined by the number of pages in the publication. Information pertaining to the pricing codes can be found in the current issue of the following publications which are generally available in most libraries: *Energy Research Abstracts (ERA)*; *Government Reports Announcements and Index (GRA and I)*; *Scientific and Technical Abstract Reports (STAR)*; and publication NTIS-PR-360 available from NTIS at the above address.

DISCLAIMER

Portions of this document may be illegible electronic image products. Images are produced from the best available original document.

ACKNOWLEDGMENTS

This work was funded by the U.S. Department of Energy through the Solar Energy Research Institute under sub-contract number XC-1-10057-15 for PVMaT phase I.

The authors would also like to thank the many manufacturers, suppliers, and fabricating companies that supplied detailed pricing information for the manufacturing cost estimates. These unrewarded efforts were essential to developing realistic cost estimates. Also, the authors acknowledge the prompt responses provided by Rick Mitchell and Ed Witt of SERI, to help complete this subcontract in 3 months.

TABLE OF CONTENTS

1.0	Introduction	1-1
1.1	SKI 300x Concentrating PV Array	1-1
1.2	General Company Goals	1-8
2.0	Current Module Manufacturing Procedure	2-1
2.1	Component Descriptions	2-1
2.2	Current Module Manufacturing Operations	2-11
3.0	Proposed Process and Design Improvements	3-1
3.1	Review of Current Fresnel Lens Manufacturing Processes	3-1
3.2	Proposed Plans for Module Manufacturing	3-15
4.0	Primary Issues for Proposed Improvements	4-1
4.1	Manufacturing	4-1
5.0	Anticipated Resolutions of Critical Issues	5-1
5.1	Manufacturing Approaches	5-1
5.2	Process Specific Approaches	5-9
6.0	Summary	6-1
7.0	References	7-1
	Appendix	A-1

1.0 INTRODUCTION

Project Summary

This report provides a summary of technical effort performed under a PVMaT phase I subcontract with Solar Energy Research Institute (SERI). The effort includes the evaluation of low-cost manufacturing of Solar Kinetics, Incorporated's (SKI) concentrating photovoltaic (PV) module and molding of the point focus Fresnel lens in large quantities at low-cost. The subcontract is SERI No. XC-1-10057-15.

The objective of this contract was twofold. First, to identify the various processing steps in the manufacture of the point focus concentrating PV module. This includes establishing complete and detailed process and material flow studies. It also includes the identification of time study for all the intermediate steps. A summary of this analysis is presented in later sections. Next, a generic automation plan is evaluated, followed by identification of generic automation equipment needs and associated cost.

The second objective of this contract was to establish the real cost of point focus Fresnel lenses when manufactured in large quantities. During this investigation various materials were evaluated. Also, different manufacturing methods were reviewed with injection molding selected as the method of choice. Various vendors were visited with extensive injection molding experience. All these vendors have molded optical grade parts for the lighting and automobile industries. The primary emphasis of this investigation was to reduce the manufactured cost of the Fresnel lens. The DOE goal of \$35 per square meter can be easily met. The cost we can achieve is \$20 - \$25 per square meter.

1.1 SKI 300x Concentrating PV Array Module

SKI is actively developing a 300x concentrating PV module (see Figure 1.1). The module design is derived roughly from the SBMIII module developed at Sandia National Laboratories in Albuquerque (SNLA). Development and testing of various module components, manufacturing processes and entire modules has been pursued at SKI since 1986. SKI anticipates marketing of two different sizes of module arrays, a 2 kW and a 10 kW. The smaller size will be applicable to remote power applications domestically and overseas. The larger array will be intended for utility applications.

The modules contain 24 cells operating at nominally 300x. (see Figure 1.2). The lenses are injection molded acrylic fresnel lenses. Under each lens is a Secondary Optical Element (SOE) which serves as a light "funnel" to assist in directing all focused light energy onto the cell. The cells are connected in series with three blocking diodes. The cells are passively cooled by their direct mounting to the modules rear

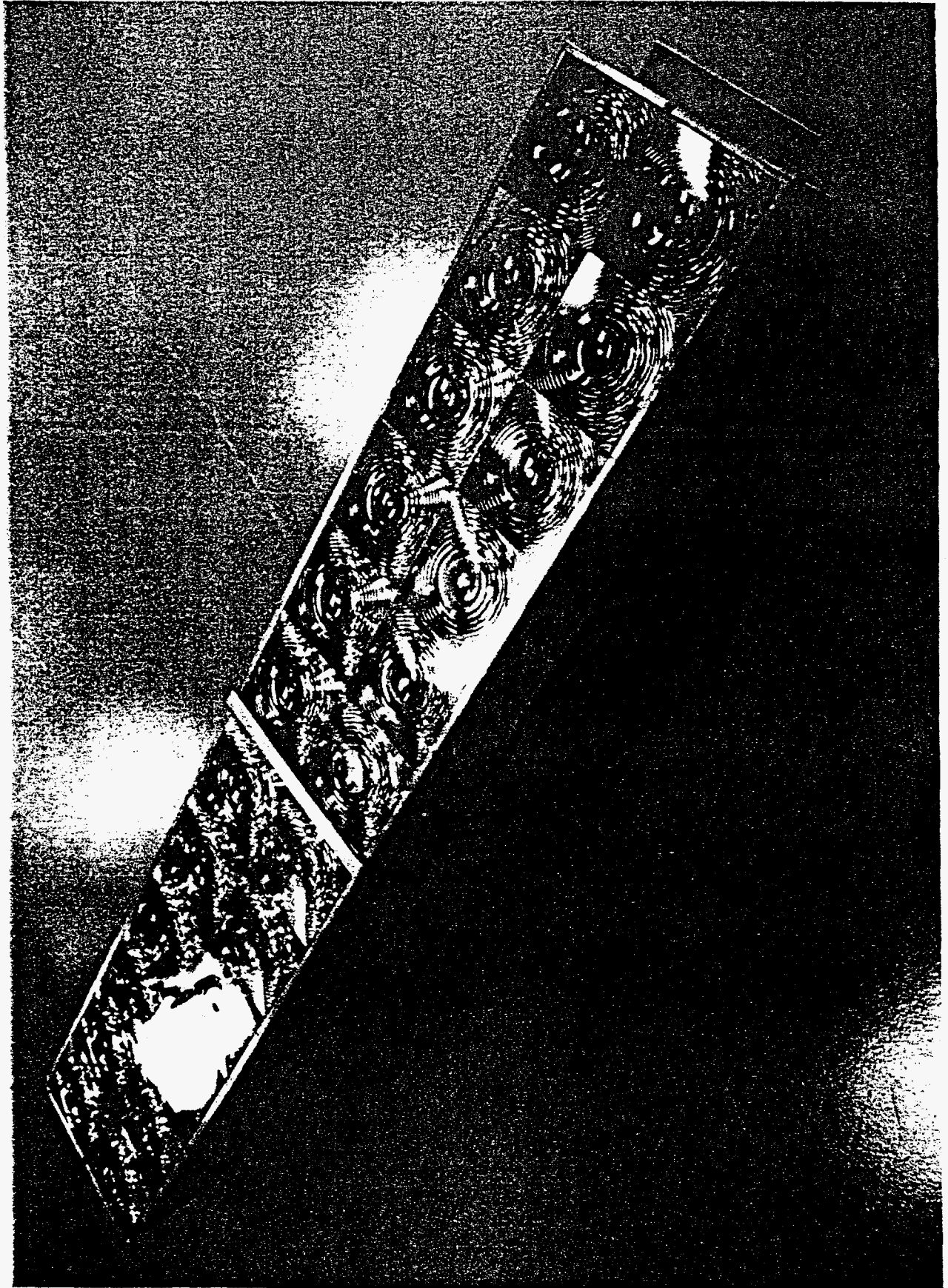

Figure 1.1 SKI 300X Concentrating PV Module.

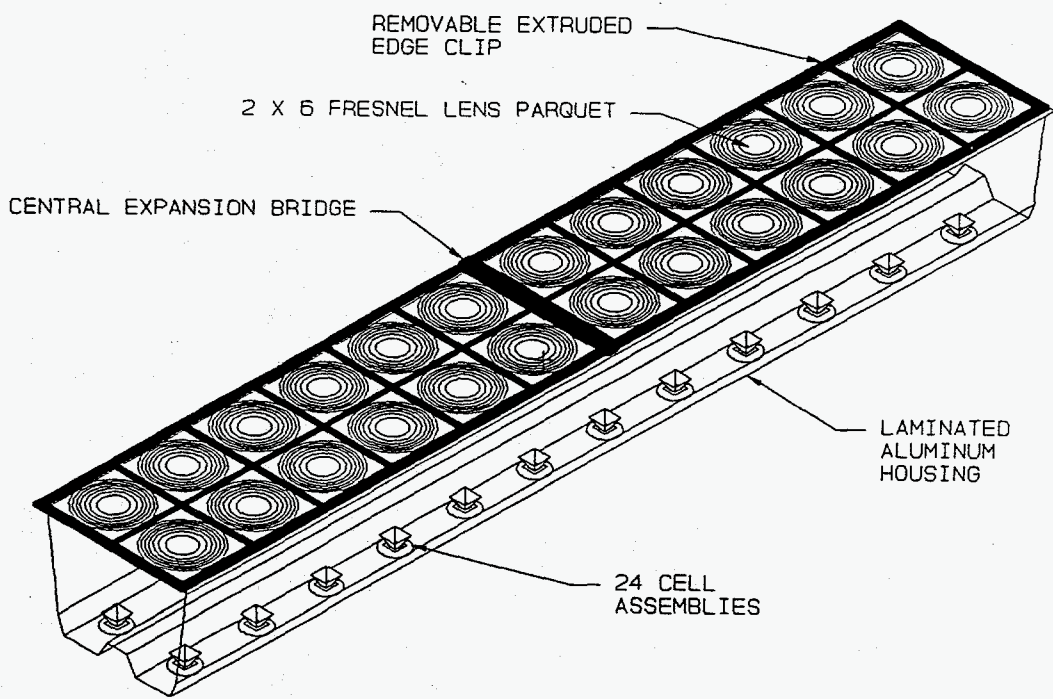

Figure 1.2 "Visible" View of Commercial Photovoltaic Concentrator Module

skin. Each cell nominally generates 4.2 watts for a gross module output of 100 Watts. Table 1.1 shows a condensed summary of the module and array specifications.

The module has a trough shaped aluminum housing covered with a flat lens panel containing 24 fresnel lenses (see Figure 1.3). The lens panel is actually 6 parquets assembled together with aluminum extrusions. Each acrylic lens parquet has four lenses molded into it. The bottom of the trough serves as the mounting surface for the cell assemblies. There is a layer of electrically insulating plastic film over the entire inside surface of the trough. The cell assemblies mount to the bottom of the trough, each cell being directly under the center of each individual lens.

Drive and Tracking Control

The concentrating photovoltaic modules are just one part of a complete system for solar power generation. Either 10 or 100 modules are combined to create a device which can generate 2 or 10 kilowatts respectively (see Figure 1.4). These devices may operate alone or as part of a larger field as determined by the quantity of power required.

The modules described previously will be assembled on a support structure to form an array. This array must be continuously oriented to precisely face the sun. The structure which connects the modules into an array and moves with the modules as they track the sun is referred to as the rear support structure. The mechanism which connects to this rear structure and turns it to follow the sun's path is the drive. The drive in turn mounts upon a support structure or pylon which transfers all wind and gravity loads on the array and drive to the mounting foundation. The electronics and sensors which direct the movements of the drive mechanism are called the tracking control or tracker.

The drive, support and tracking sub-systems are designed to be high performance products with optimum use made of commercially available materials and components. As in the module design, highest quality components and assembly techniques are utilized to achieve the lowest life cycle cost of energy produced. This does not always lead to lowest initial cost but does produce advantageous overall economical performance over the entire life cycle of an energy system. This attention to quality means lower reject rate during manufacturing, simplified installation, better performance initially, less degradation of performance with time, and fewer failures in the field.

Where off-the-shelf tracking, drive and, to a lesser extent, support structure components can be used, they will be selected to provide best life cycle cost of the energy produced. For some components, early commercial models will use existing commercially available parts. As product volumes increase and manufacturing and field experience accumulates, it will become cost effective to custom manufacture various components. During the earlier phases of production, use of off-the-shelf

TABLE 1.1
SKI 300x CONCENTRATING PV ARRAY CONCEPT SUMMARY

DESIGN PARAMETERS	SPECIFICATIONS	
Optics Type	Point Focus	
No. of Cell Assemblies	24	
Type of Cell	Single Crystal Silicon	
Concentration Ratio	282x	
Cell Active Area	0.048 sq.m.	
Type of Cooling	Passive	
Cell Operating Temperature	65 °C	
	2 KW	20 KW
Number of Modules	20	200
Array Effective Aperture	15 m ²	150 m ²
Total Array Weight	3000 LB.	17000 LB.
Type of Tracking	Elevation Over Azimuth	Elevation Over Azimuth
Performance		
Optical	0.8	0.8
Watts/Array	2 KW	20 KW
Watts/Module	100	100
Watts/Cell	4.2	4.2
Watts/lbm.	.67	1.18

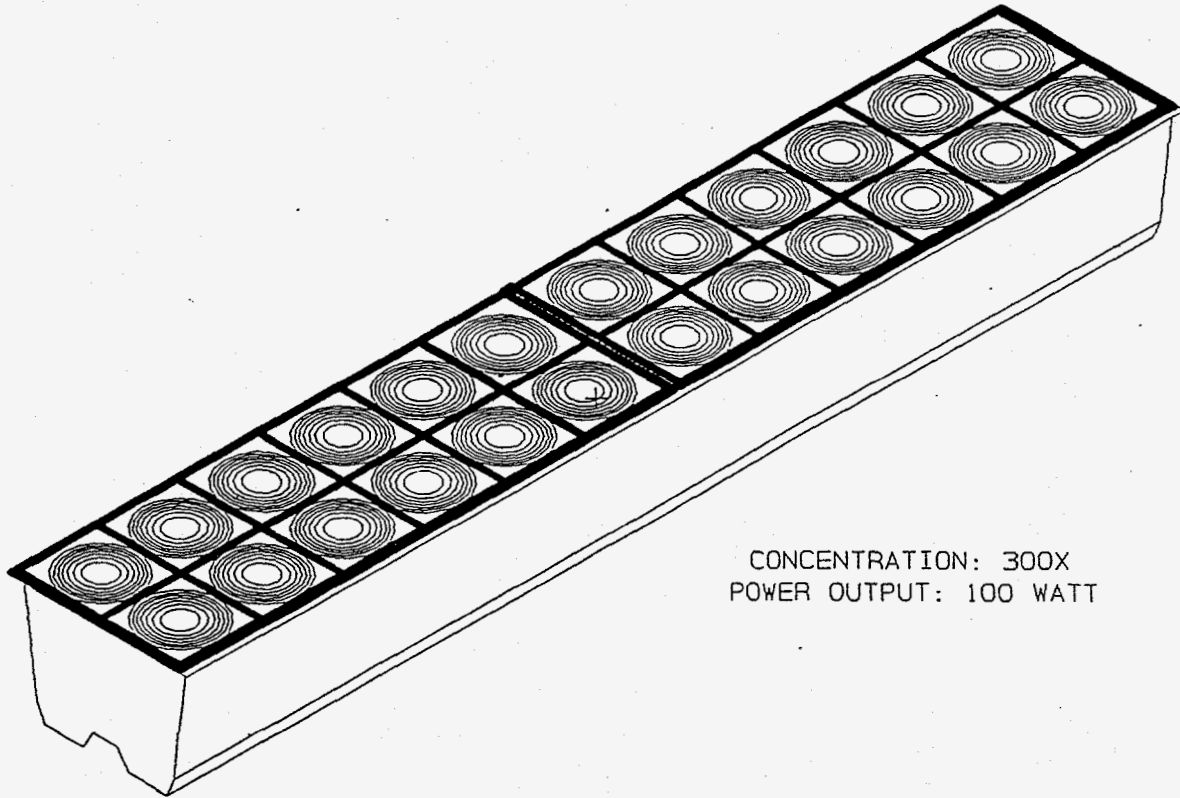

CONCENTRATION: 300X
POWER OUTPUT: 100 WATT

Figure 1.3 Commercial Photovoltaic Concentrator Module

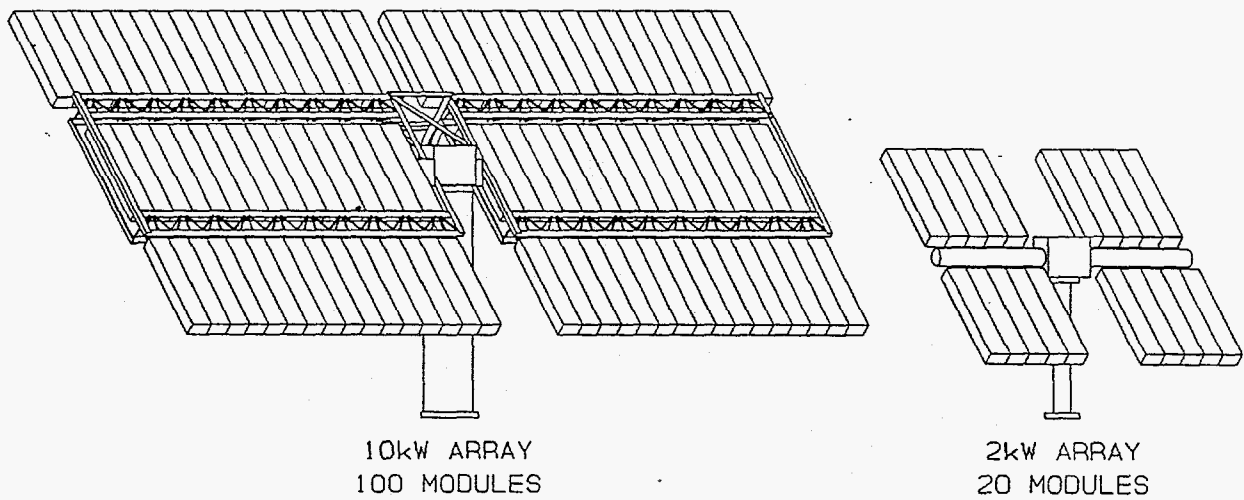

Figure 1.4 10 kW and 2 kW Array Configurations

components will reduce manufacturing start-up problems and allow more effort to be spent on the critical processes which are unique to photovoltaic module production. The use of off-the-shelf components can also increase the reliability of the first commercial units by reducing the number of unproven critical components in the collectors. Even after extensive laboratory testing and prototyping, there are unanticipated problems associated with introducing new technologies and products. Judicious use of components developed for and proven in other industries will allow more trouble free introduction of these products.

1.2 General Company Goals

Since its founding in 1975, SKI has been in the business to provide complete solar energy systems. Initially the systems were concentrating parabolic troughs producing industrial grade process heat and electrical power. These systems were always of the highest quality and performance as befits a long term capital equipment investment. SKI designed, manufactured and installed the collectors and balance of plant equipment to deliver energy in the form needed for that customer; high temperature water, low pressure steam, high pressure steam or electricity.

SKI is following the same approach for photovoltaic power production for anticipated future markets. A high performance, high quality module is supported on a robust and accurate drive and support system. Two sizes of arrays accommodate varying customer needs.

The first product introduced will be a nominal 2 kW array. Niche markets for small units such as this will support the higher pricing inevitable with low start-up manufacturing volumes. There is a higher risk of technical problems with new products and technologies in both their manufacture and field operation. The associated economic risk can be reduced by first introducing the lower cost unit in moderate volumes. The experience gained with this model will be invaluable when planning and implementing the production and operation of subsequent larger units in higher volumes.

The most attractive long term market is probably for utility scale installations where a single field contains mega-watts of installed modules. The production of low volumes of smaller modules is planned to fine tune the component designs and manufacturing processes.

2.0 CURRENT MODULE MANUFACTURING PROCEDURE

2.1 Component Descriptions

Lens Panel and Lenses

The current design for a lens panel uses two parquets, 2x6. A parquet is a set of individual square lenses, used by SKI, arranged in columns and rows to form a larger rectangle, in this case 2 lenses wide and 6 lenses long. The two parquet panel approach was developed to minimize assembly operations, reduce total part count and reduce total length of lens seals to minimize potential leaking. The design was based on the assumption that molding such parquets would be a surmountable manufacturing challenge. This assumption must be reevaluated as to date, only single lenses have been successfully molded.

The lens currently being used is only available as a single lens. It is an injection molded acrylic fresnel design developed by American Optical with SNLA (see Figure 2.1). Actual concentration ratio is 282x. The lens was designed by SNLA. The design uses variable width, constant depth, curved face facets. The active area major dimensions are 6.8 inches by 6.8 inches. Nominal thickness is .245 inches. The lens is described more fully in Figure 2.2.

To produce prototype modules for testing, complete lens panels were required. The original design used two 2x6 parquets. Parquets were fabricated by machining away the edge area of the lenses on one side and solvent welding the lenses together (see Figure 2.3). This process was successful for a prototypical operation. The bonded area between the lenses is probably a weak point in this panel. If this approach were to be used in production some special interlocking edge contour would be molded into the lens edges to increase the bond area and provide self aligning during assembly.

Various issues had to be addressed after receipt of the single lenses. These lenses were injection molded in prototype tooling, and had flat rims around two adjacent edges as shown in Figure 2.1. As mentioned above one edge of the lenses was machined off accurately before the lenses were solvent bonded to obtain a 2x6 parquet as shown in Figure 2.3. This assembly of lenses was done on a surface table using fixtures. Another problem the individual lenses has was convex crown on the smooth side. Before we could solvent bond these lenses, we had to flatten them. This process was done by bringing the lenses above its glass transition temperature (T_g) of 185°F, and maintaining it for 2 hours so gravity flattened it. Without going through this flattening operation it would be difficult to solvent bond these lenses to form a 2x6 parquet.

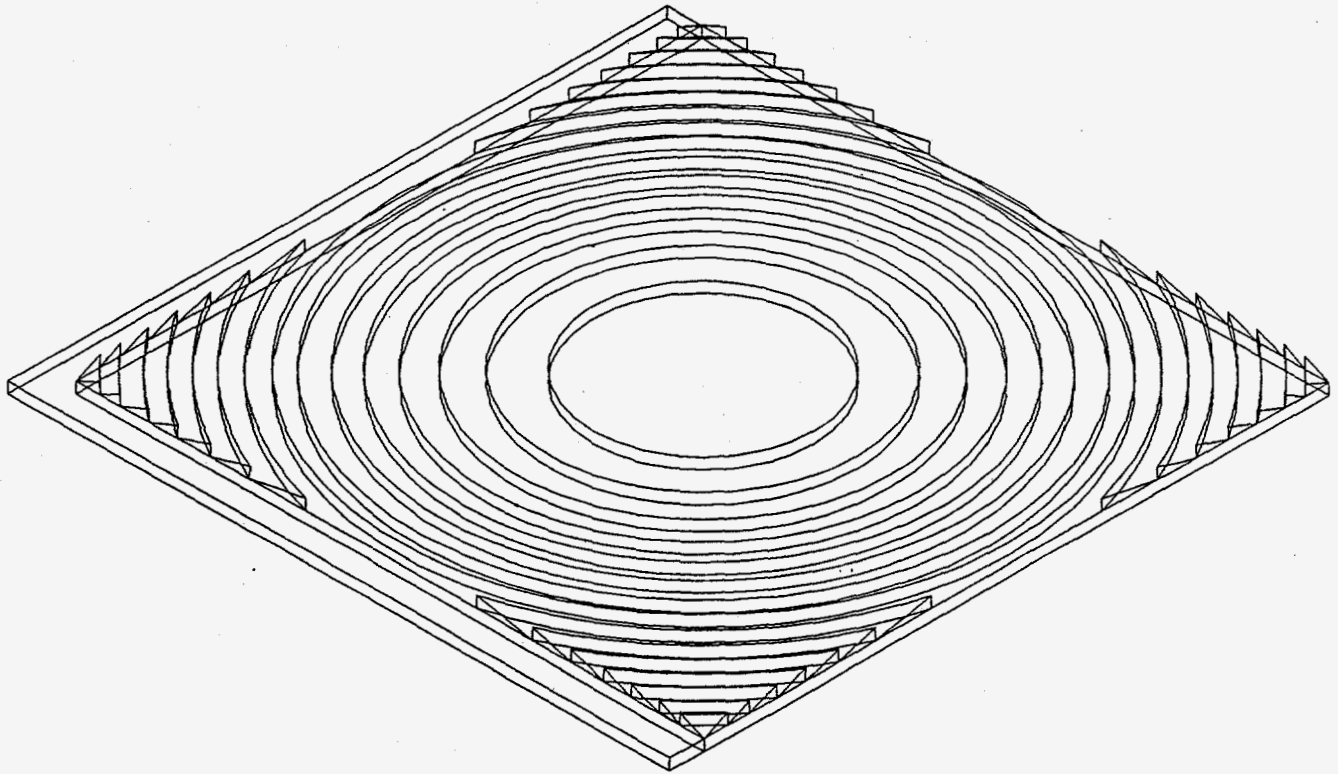
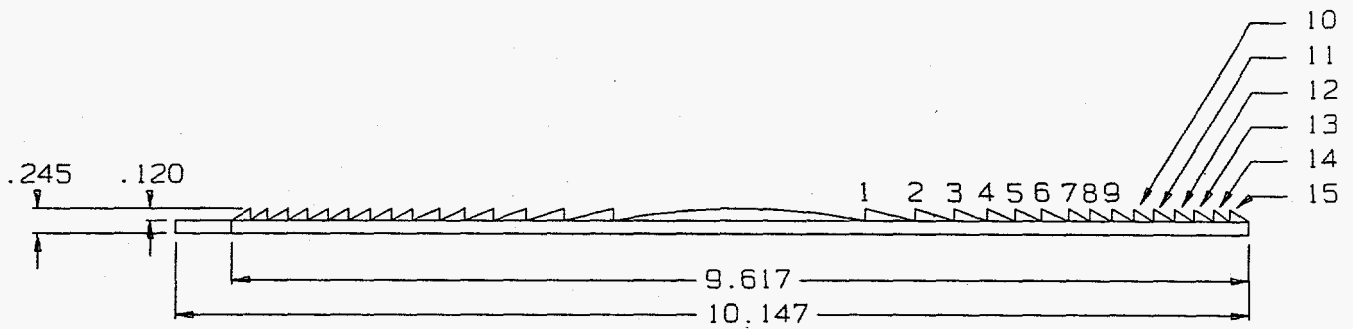

Figure 2.1 Current Single Fresnel Lens



FACET	I. D.	ANGLE
1	2.391	14.2°
2	3.342	18.3°
3	4.068	21.2°
4	4.686	24.0°
5	5.226	26.0°
6	5.718	24.5°
7	6.245	31.6°
8	6.635	30.3°
9	7.047	30.3°
10	7.457	32.4°
11	7.835	32.3°
12	8.215	33.3°
13	8.579	32.3°
14	8.959	39.0°
15	9.256	31.6°

Figure 2.2 Cross Section of Current Fresnel Lens

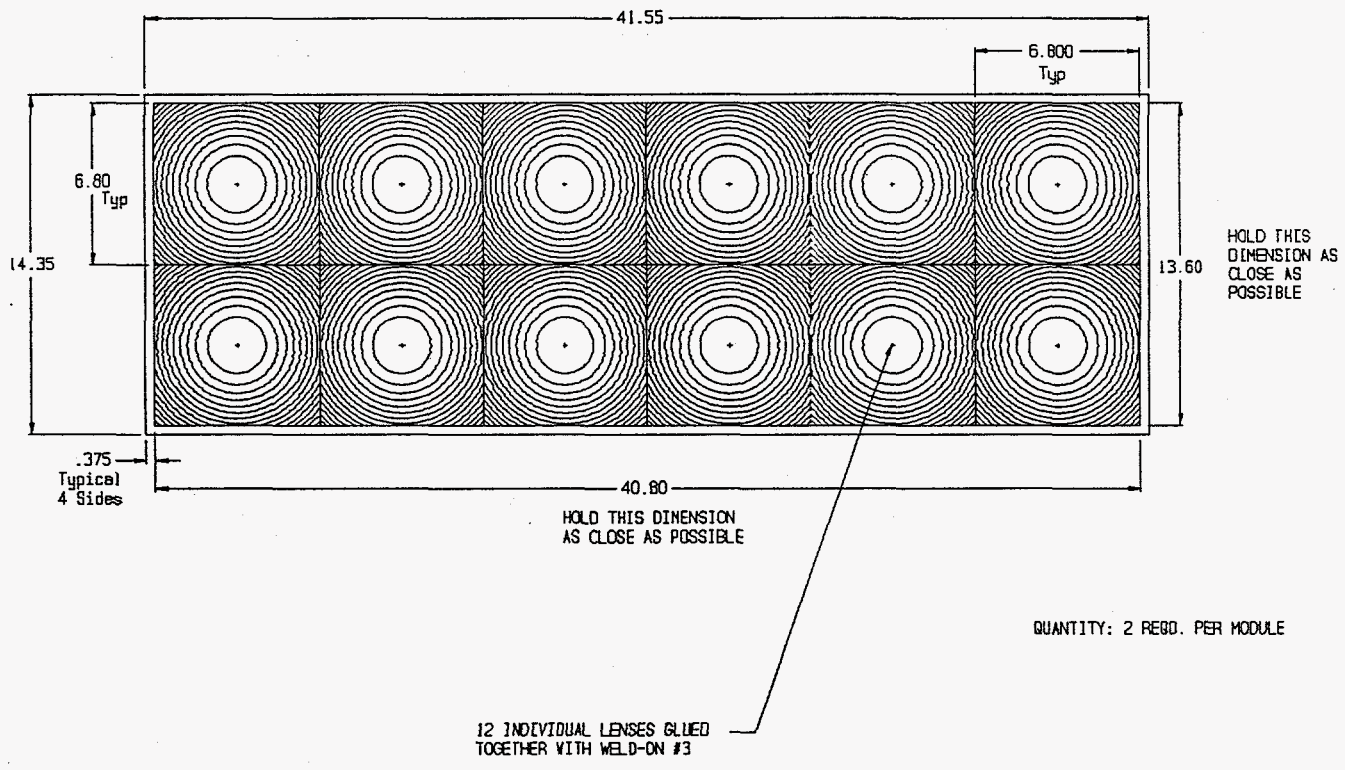

Figure 2.3 Current 2 x 6 Fresnel Lens Parquet

Cell Assembly

Extensive cell assembly fabrication and testing activities are being conducted. Sandia performed the cell assembly qualification tests and the performance testing for the qualified module cell assemblies. Figure 2.4 displays a cell assembly.

The current cell assembly consists of five components: solar cell, heat spreader, top contact, bottom tab, and secondary optical element. This section describes the procurement and/or fabrication of for each of these components. Twenty four cell assemblies are connected in series to make a 100W module. The cell specified for the prototype module has been designed and fabricated by the Applied Solar Energy Corporation (ASEC).

The concentrator solar cells are made from P-type float zone silicon of 0.2 ohm-cm resistivity. The active cell area is 1 cm x 1 cm and the thickness of the cell is 0.008". These cells are single crystal silicon concentrating cells. They have a Chevron type grid pattern on the front and a busbar along the perimeter of the square cell. The back of the cell is completely silvered. The average efficiency of these cells is 17% at 300X concentration, 85 mW/sqcm and 25°C. In the near future these cells will be pretinned by the cell vendor. This will eliminate the process steps associated with pretinning during the fabrication of the cell assemblies.

The N + junction is formed by thermal diffusion of phosphorus. To enhance the electrical output of the cell, a boron diffused back surface field is applied to the P-side of the cell. Photolithography is used to define the grid pattern of the N-contact. The metallization systems for the front and back contact are Ti-Pd-Ag and Al-Ti-Pd-Ag respectively. To minimize series resistance, the silver thickness of the N-contact will be 7-10 micrometers thick. Finally, to reduce the reflection loss, a dual layer of anti-reflective coating of titanium oxide and aluminum oxide will be evaporated onto the active surface of the cell. The cell is then inspected for mechanical defects and tested for electrical output. The detailed specifications of the PV cell being used in the SKI module are in the Appendix.

Top Contact

The top contact is currently fabricated by precision stamping and forming operations at SKI. Other fabrication processes, namely chemical milling, tend to be more expensive and still have to be followed by precision forming. These tabs are pretinned with a 62/36/2 (Sn/Pb/Ag) solder alloy. The following outline describes some of the issues associated with selecting a lens manufacturing process.

Module Drive and Support Description

Both array sizes will use an elevation over azimuth drive. The drive will mount on a simple tubular pylon set in a cast-in-place concrete pier. The rear support structure consists of one or two backbones parallel to the ground. Brackets extend from both sides of the torque tube to support the modules. The modules are all positioned with their long dimension at a right angle to the backbone. (See Figure 2.5)

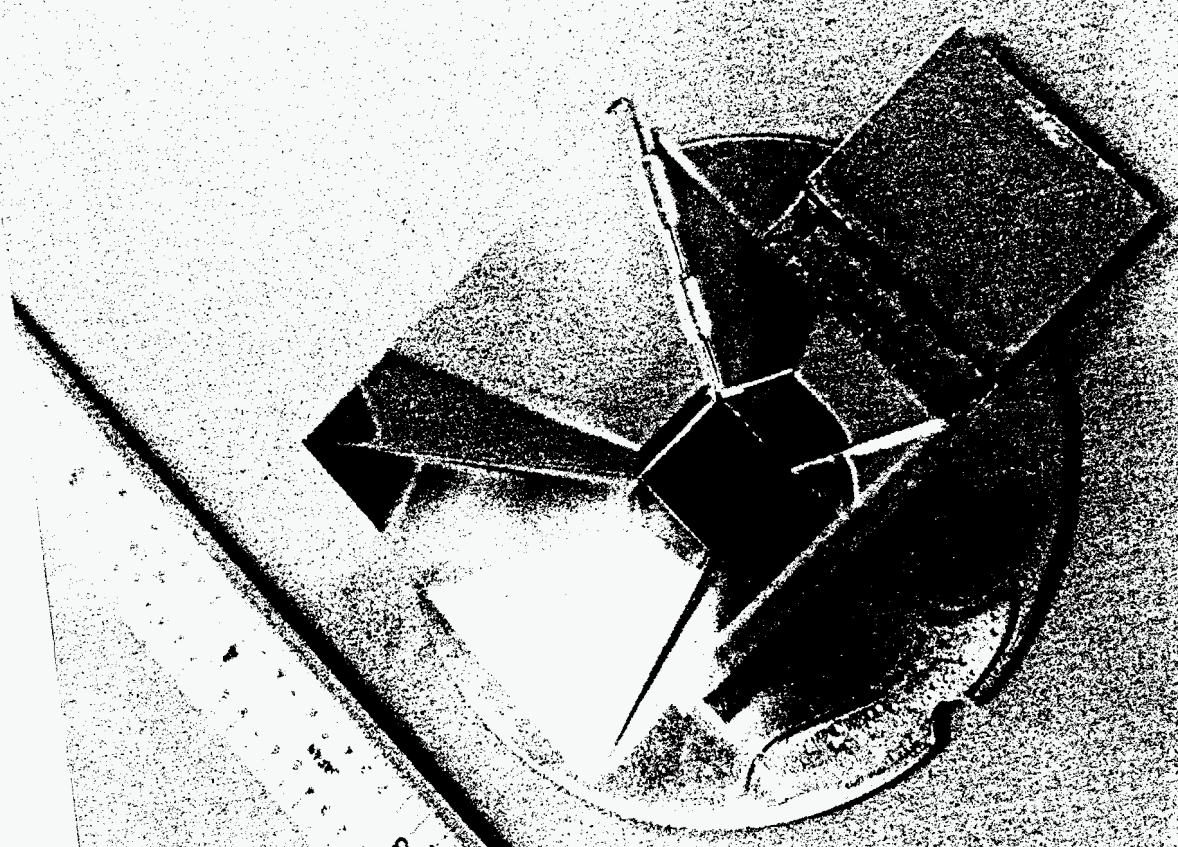

Figure 2.4 Detail of Solar Cell Assembly.

Rear Support Structures

Both array's rear support structures are fabricated from standard shapes of structural and bar steel. Subassemblies are shop welded to reduce cost and maintain quality control. Most steel assemblies are hot dip galvanized to assure extended corrosion resistance. Field assembly requires only bolting, no welding.

The small array's backbone is actually a single closed tube acting as a torque tube. The modules are supported at one end directly by the torque tube. They are supported at a second point in the center of the back side by a simple bracket cantilevered from the torque tube. The modules are partially self-supporting.

The large array uses open three-dimensional trusses for the backbones. (See Figure 2.5) Module support points will be identical so that the same modules can be used as on the smaller array.

The rear supports are made from standard steel shapes so there are no availability problems. The fabrication could be done by SKI or subcontracted. There are numerous qualified fabricators for this type of work throughout the country.

Drive

The small array azimuth drive is somewhat specialized. There is not an industry standard for solar array or satellite orientation. There are however several gear reducer/drive manufacturers with suitable products. Because of the lack of standardization, the interface to the elevation drive would be unique for each manufacturer's unit. This will not present fundamental manufacturing problems.

The small array azimuth drive may be a purchased gear reducer from the satellite dish industry. The 20 m² area is equivalent to a 16 foot diameter dish. The elevation adjustment is provided by a standard commercial electric linear actuator. A custom weldment will interface the azimuth output to the elevation drive.

The large array azimuth drive utilizes a standard large diameter combination internal ring gear and bearing for the azimuth mount and final gear reduction. The internal ring gear pinion is driven by a standard commercial primary gear reducer. (See Figure 2.6) The elevation angle is again adjusted by a larger standard commercial electric linear actuator. A custom weldment will attach to the rotating stage of the large diameter bearing. The elevation bearings and linear actuator will mount to this weldment.

Another alternative to the large array drive exists from heliostat development work funded by SNLA. Peerless-Winsmith Company has designed and tested a drive for a 150 m² heliostat^[1] which has almost the same performance requirements as the PV array. This unit uses elevation over azimuth. The azimuth stage uses a single bearing in a custom cast housing. The azimuth gear reduction uses a multistage gear train with a unique plano-centric final gear reduction. It provides good stiffness and

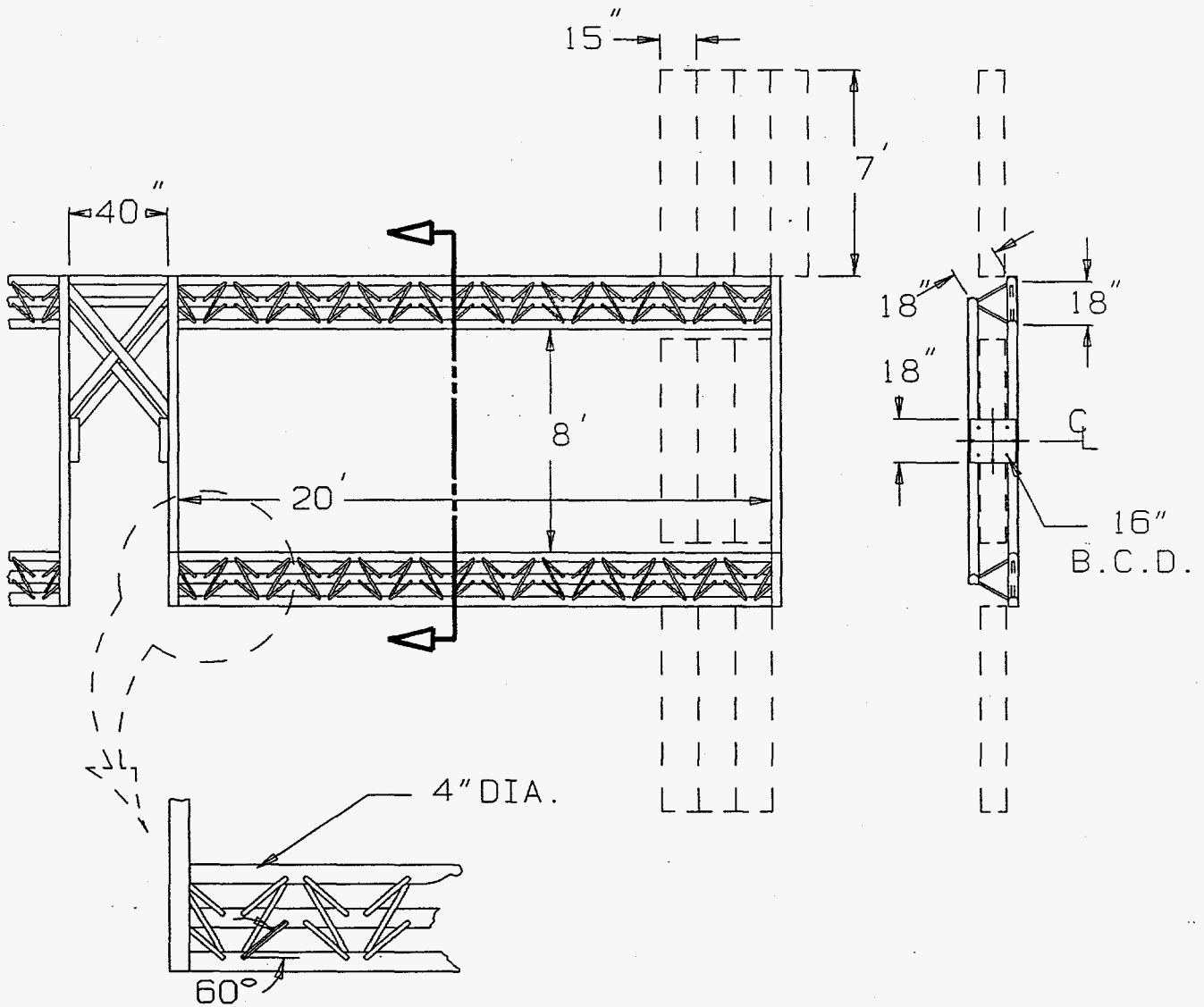

Figure 2.5 10kW Array Module Support Module

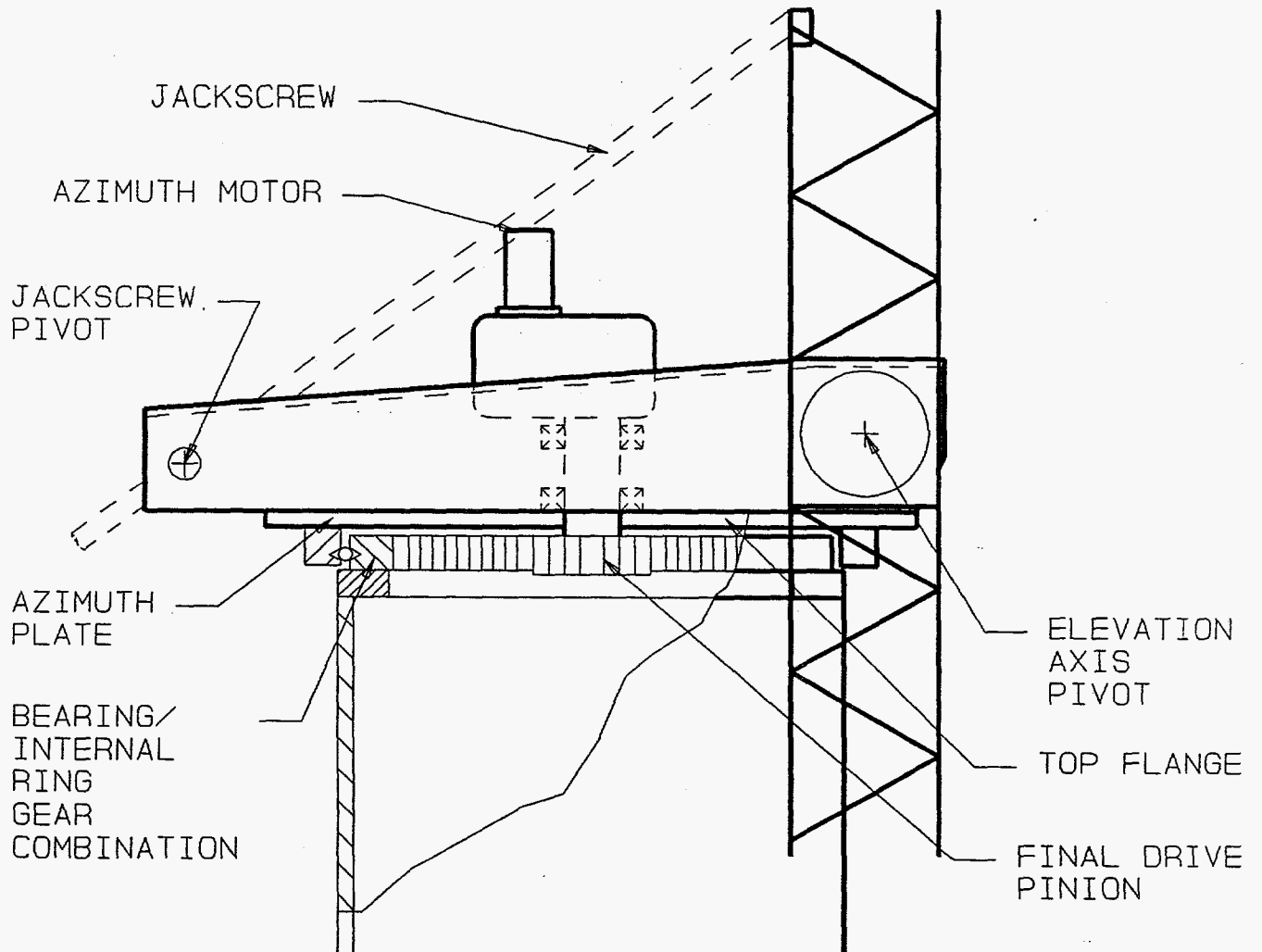

Figure 2.6 20kW Array Drive

high load capacity and reduction ratios in a compact unit. The elevation is accommodated with an electric linear actuator as originally proposed.

This unit is expensive in low quantities but may be cost effective for larger volume manufacturing. If the 150 m² drive is not ideal for the PV array, it can be resized for a modest engineering effort since most of its fundamental features have already been well defined. This option should be considered for higher volume manufacturing. In making this decision several factors must be evaluated. These include delivery, pricing, parts availability, and serviceability.

Tracking Control

The tracking control is identical for both arrays. Initially a standard industrial programmable logic controller (PLC) will be used to provide synthetic tracking. Position encoders on the azimuth and elevation stages will provide feedback to the controller. A single controller is capable of operating several arrays simultaneously. The controller can operate autonomously because of its onboard battery backed-up clock and calendar. The motors for the drive are permanent magnet DC variable speed units with a common SCR controller.

When production volume justifies a custom designed and manufactured controller the PLC can be replaced for a potentially significant cost savings.

The PLC used in the tracking control is a Modicon series 984. It was selected because of its powerful floating point higher math capabilities, including direct and inverse trigonometric functions. It is currently unique in offering these features. Competition in the industry will probably change this situation within a year or so. Meanwhile the use of the Modicon does not appear to cause any potential supply problems because of the size and stability of Modicon's parent company, AEG International.

The nature of a PLC is to be a general purpose flexible controller. By design it has many features, all of which are not necessarily required for a given application. Therefore, a user of a PLC usually is buying some capability which is not needed. The PLC manufacturer can build a single general purpose PLC in vast quantities since it can work on many different applications. The end user benefits by this volume because the PLC will often be less expensive than an application specific, dedicated controller which is sold in much smaller volumes. When a user, however, has a sufficiently large demand for a single controller, a dedicated controller may be more cost effective than a PLC. The breakeven point for switching to a dedicated controller needs definition for this application.

The encoders, PM motors and SCR motor controllers are very generic in nature and available from numerous manufacturers. There will be no fundamental supply problem for these items.

2.2 Current Module Manufacturing Operations

Solar Cell Assembly. The solar cell assembly consists of 6 components. The current assembly procedure as currently executed is diagramed in Figure 2.7. Each component requires some fabrication or processing prior to assembly.

Solar Cell: The solar cells are visually inspected upon receipt. The backs are cleaned by wiping with an organic solvent. The cell back is fluxed and the cell placed face down on a cool soldering platen. A square of solder film is cut to fit the area of the back of the cell. It is placed on the cell and the platen heat activated to flow the solder thereby pretinning the cell back. The cell and platen are allowed to cool and the cell transferred to in-process storage.

Heat Spreader: The material for the heat spreader is currently received in sheet form. In the first operation the sheets are manually loaded onto a CNC turret punch. The punch die stroke is controlled such that the heat spreader disk is not entirely separated from the sheet. It is sheared all the way around the perimeter, but the punch stroke is stopped before the disk is pushed through the parent sheet. The sheet is taken off the press and the parts manually separated from the sheet. This is done to prevent potential damage such as nicking or bending which could occur if the press ejected the parts in the normal manner. The spreaders are manually deburred immediately after removal from the sheet. The turret punch press is shown in Figure 2.8.

The next operation is flattening. A press with a flat ram and platen squeezes the heat spreader to remove any bowing resulting from the stamping operation.

Finally the part is acid etched, rinsed, fluxed and pretinned on one side in a similar method as used on the cell.

Bottom Contact Tab: The copper for this component is received in the form of flat coil stock. It is sheared to length and then formed in a custom die set in a single station press.

Next the part is acid etched, rinsed, fluxed and pretinning applied to the surface to be soldered to the heat spreader.

Top Contact: This intricate part is made from sheet stock. In the current operation, a large sheet of copper is taped to a backup sheet of thin aluminum to serve as a carrier during the punching operation. This assembly is loaded into the CNC turret punch where a series of fine rectangular dies blank out the interior dimensions of several dozen parts on the same sheet. The center contours of each part are knocked out to allow forming of the contact fingers. A forming tool is in place in the turret punch at one station to form the contact fingers. When the sheets are removed from the turret punch, the contacts are simply sheared

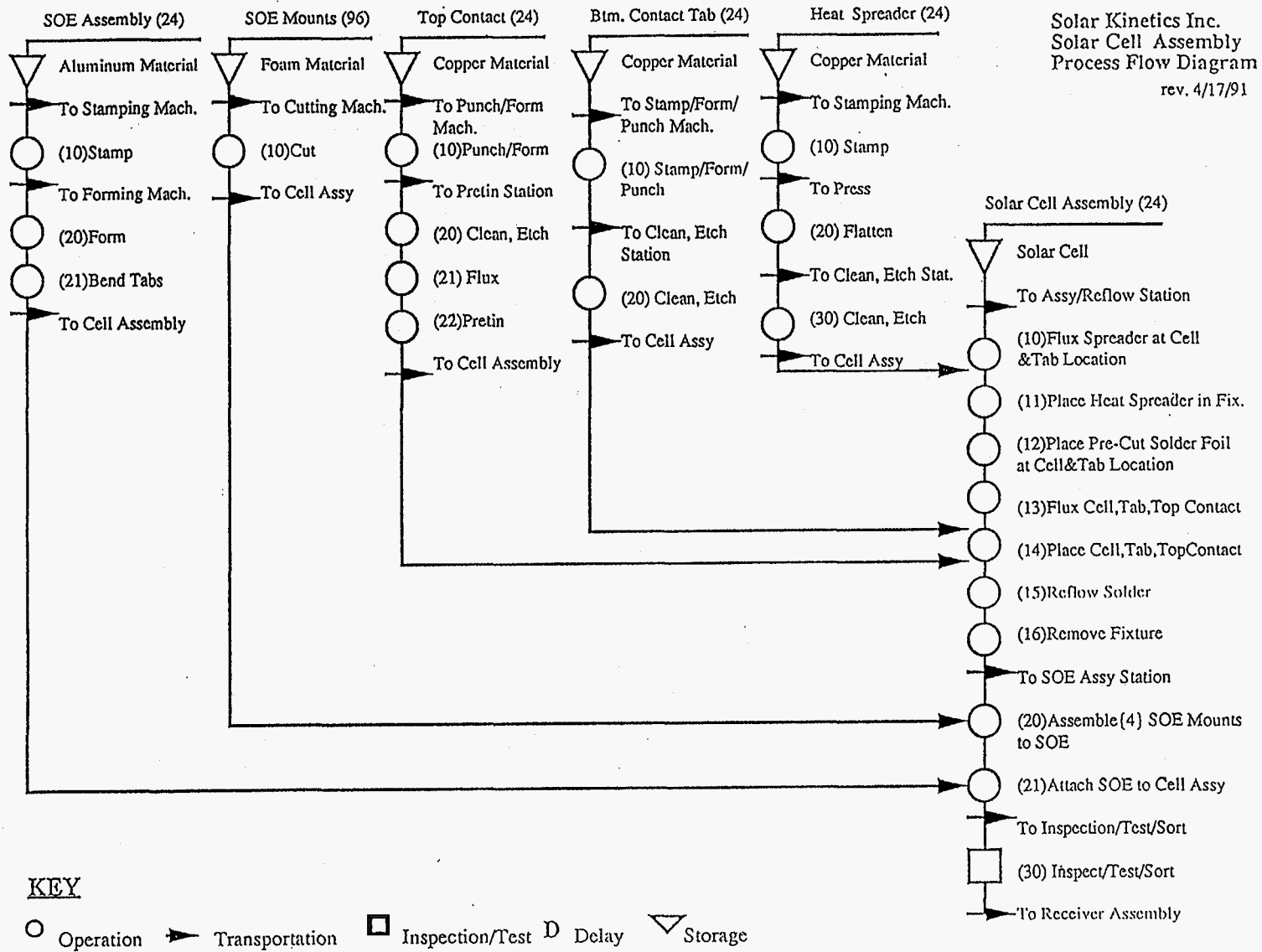
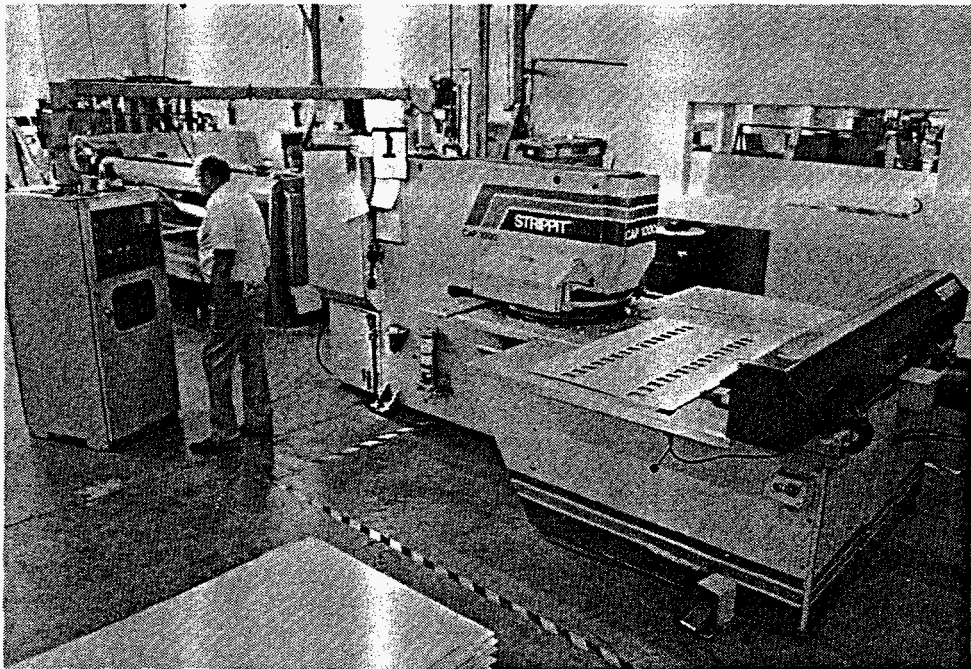

Figure 2.7 Solar Cell Assembly Process Flow Diagram.



**Figure 2.8 Turret Punch Press Used for Fabrication of Heat Spreader,
Top Contact and Secondary Optical Element**

apart, their contours already complete. A secondary forming tool in a single station press is used for final adjustment of the contact fingers to assure uniform height.

The contacts are acid etched, rinsed fluxed and pretinning applied. Pretinning is used only where the contact finger tips will rest on the cell edges and where the top interconnect attachment tab will solder to the cell interconnect strap.

Secondary Optical Element (SOE): The SOE material is delivered prepolished in sheet form. The flat parts for the pyramid final shape are blanked out most of the way on the CNC turret punch. Connecting fingers are left in place to allow a sheet's worth of parts to be removed from the punch as a single piece. The individual peaces are separated by simple shearing of the connecting tabs.

In the current operation, each SOE is bent using custom Delrin bending dies in a small press brake. This polymer tooling is used to avoid marking the polished SOE material. The locking tabs are inserted through the slots and bent over and crimped to finish the assembly.

SOE Mounts: SOE mounts are made from double sided foam tape using a pressure sensitive adhesive with peel off release liner on both sides. The tape is sheared to size with the release liner still on.

Assembly Operation for Solar Cell Assembly: The current assembly operation starts with the heat spreader, pretinned cell and bottom contact tab. Each is fluxed in the area to be soldered. The heat spreader is set into the assembly fixture and a precut rectangle of solder set where the cell and contact tab will attach. The cell and bottom contact tab are placed in the fixture next. Finally the top contact is set in place. The entire loaded fixture is placed on a temperature controlled heated platen with internal resistance heating coils. The temperature is increased until all the solder reflows and then the assembly is allowed to cool again.

After cooling the assembly is removed. The release liner on one side of the SOE mounts are removed and the mounts are adhered to the SOE. The release liner is then removed from the other side and the SOE is affixed to the cell assembly.

The inspection and testing follows. The cell characteristics are noted to allow assembly in matched sets for optimum module performance.

Automated Cell Assembly

Cell assembly is a critical process sequence that other workstations feed into and that supplies critical assemblies to downstream operations. For the purpose of analyzing throughput factors, the main assembly sequence can be considered a single workstation. Below is an outline of the cycle for workstation 1. It is based on the use of robots for component assembly.

Operation: Cell Assembly			
Oper. #	Operation	Hr/Pc	Pc/Hr
10	Flux heat spreader	0.0014	720
11	Place heat spreader in fixture	0.0014	720
12	Place pre-cut solder foil	0.0014	720
13	Flux cell/tab/top contact	0.0042	240
14	Place cell/tab/tope contact	0.0014	240
15	Reflow solder	.0333	30
16	Remove fixture	0.0028	360
	Sub-total	0.0459	21.79
Process time at workstation 1 for a module.		1.1016	0.91

Note: That almost a full hour is required to assemble the cells for a single module even in this automated operation. Additional process and design changes are needed to increase the production rate here.

Receiver Assembly

The receiver assembly includes all the cell assemblies and the interconnects and diodes for a complete module. The current manufacturing process flow diagram in Figure 2.9 diagrams the operations originally used to assemble the receiver assembly. Original practice was to first install the cell assemblies in the module housing and then make all the required interconnections. Experience with this approach has lead to the current practice of preassembling all cell assemblies and interconnects prior to installation in the module housing. This permits more efficient tooling use since a single fixture places all cell assemblies simultaneously. Also the manual activities of installing the interconnects and diodes are more easily accomplished in a wide open fixture rather than within the confines of the module itself.

Module Mounts

The module mounts are simple fabricated sheet metal parts. They are sheared and bent from aluminum sheet.

Pan End Caps

The pan end caps are stampings supplied by an outside vendor. During the forming operation holes are also punched for the module-to-module cable connection bulkhead fittings. The parts are relatively simple to fabricate and require tolerances well within standard commercial practices.

After receiving the end caps, the areas where the module mounting brackets are to be spot welded are prepared by solvent wipe and mild abrasive cleaning. They are

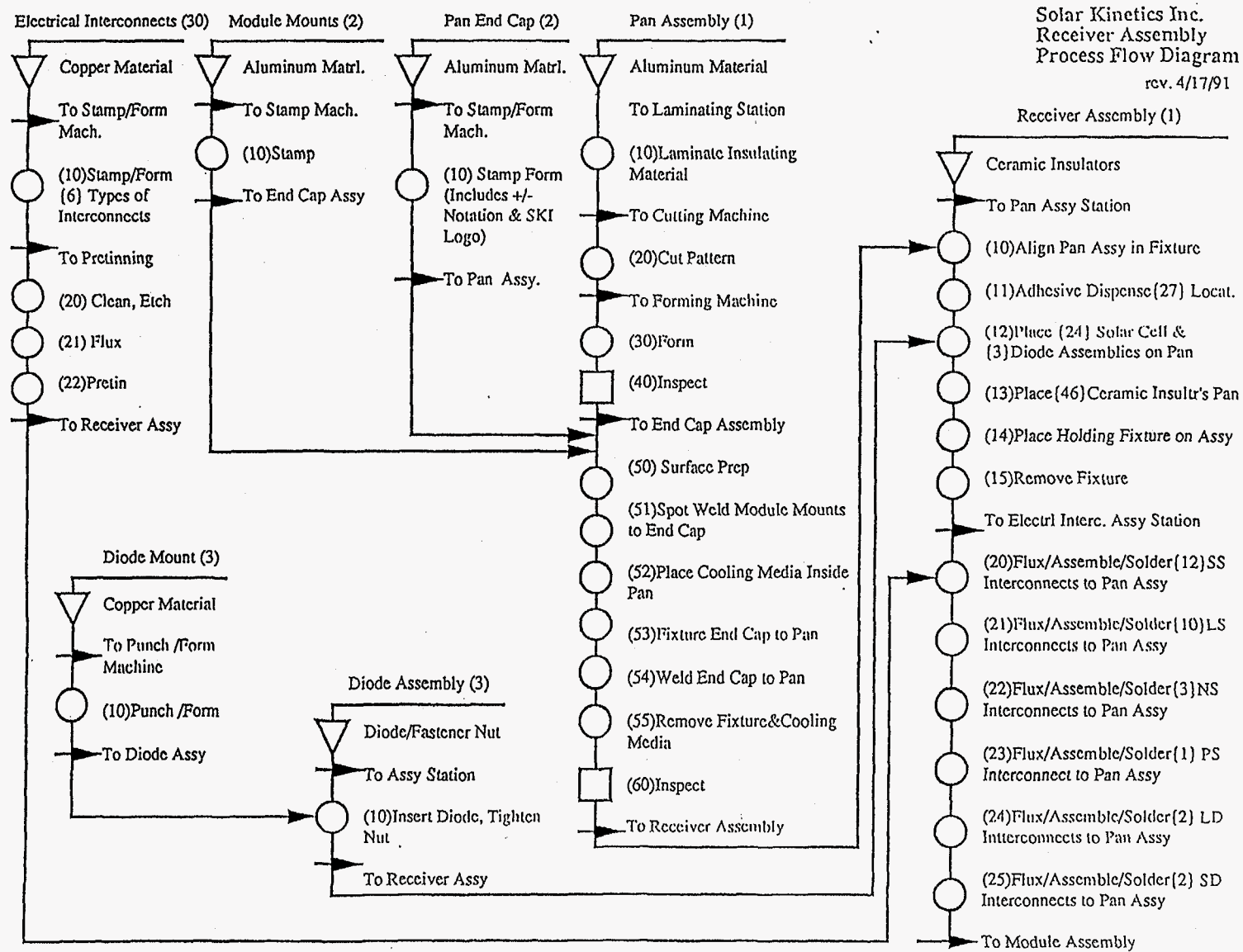

Figure 2.9 Receiver Assembly Process Flow Diagram.

spot welded to the exterior surface of the end cap in a manual single station resistance spot welder.

The same electrical insulating polymer film used on the main pan assembly is next individually laminated to the inside surface of each end cap.

Pan Assembly

The pan assembly, also referred to as the module housing, is made from aluminum coil stock. It is laminated on what will be the housing inner surface with an insulating polymer film to provide electrical isolation from the electrical circuits inside the module. Lamination is a continuous coil processing operation involving uncoiling, leveling, dry laminating and sheeting or cut-off as shown in Figure 2.10. The sheets are taken to a CNC semi-automatic press brake. Here an operator orients the sheet in the press and the press sequentially bends the part according to preprogram backstop positions and ram closing heights. The stop and closing height settings determine the location and degree of each bend. Special soft dies and pressure distributing bladders are used to insure uniform and repeatable bends. The automated backstops provide excellent accuracy of bend location to maintain correct lens-to-cell spacing. Such a press brake is shown in Figure 2.11.

In preparation for end cap installation the film is peeled away from the ends of the housings where the end cap will be fitted. The areas to be welded are prepared with a solvent wipe and light abrasive cleaning.

The housings are set in a fixture to maintain the cross sectional shape as required. The end caps are fixed in place with their lips flush with the outer edge of the housing edge. A temporary cooling media is placed on the inside corner where the housing and end cap meet to serve as a heat sink during the next welding step. The edges of the housing and end cap are continuously fused without use of additional filler metal using a GTAW (Gas Tungsten Arc Welding) weld process (see Figure 2.12). The cooling media is removed and the laminate edge smoothed down against the cooled metal. Additional silicone RTV sealant is applied to ensure complete isolation of the metal housing from the module interior volume.

The completed part currently is dimensionally checked by a coordinate measuring machine for adherence to tolerances.

Diode Mount

The diode mount serves both to support and locate the diode and serve as a heat spreader for the diode. The copper part is stamped from sheet in a similar fashion to the cell heat spreader. It also has a hole for the diode mounting stud. After punching it is bent in a small manual press brake.

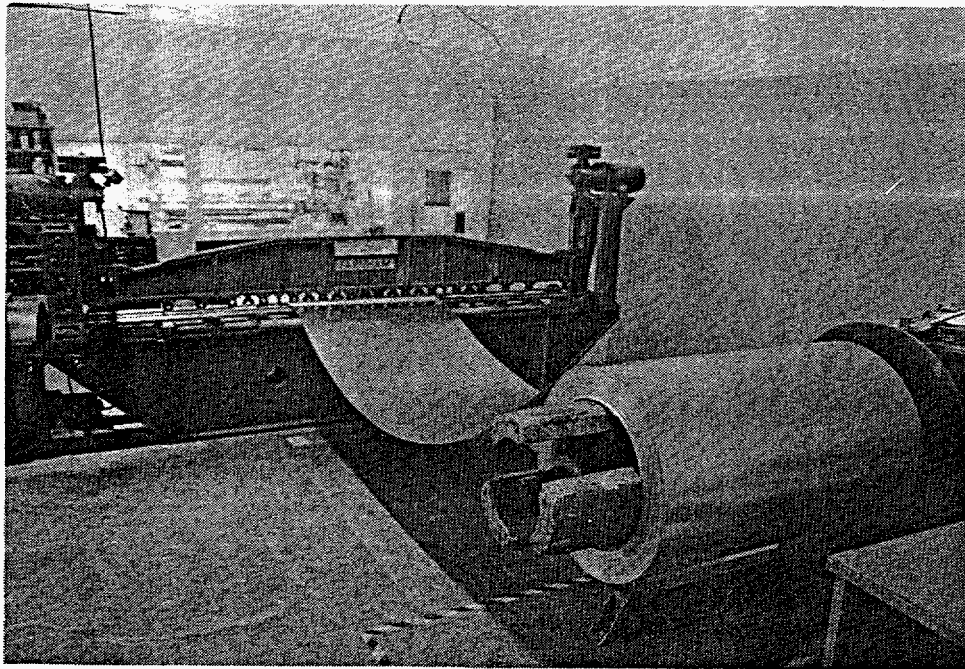

**Figure 2.10 Uncoiler, Leveler, and Dry Laminator
Used for Fabrication of Aluminum Module Housing**

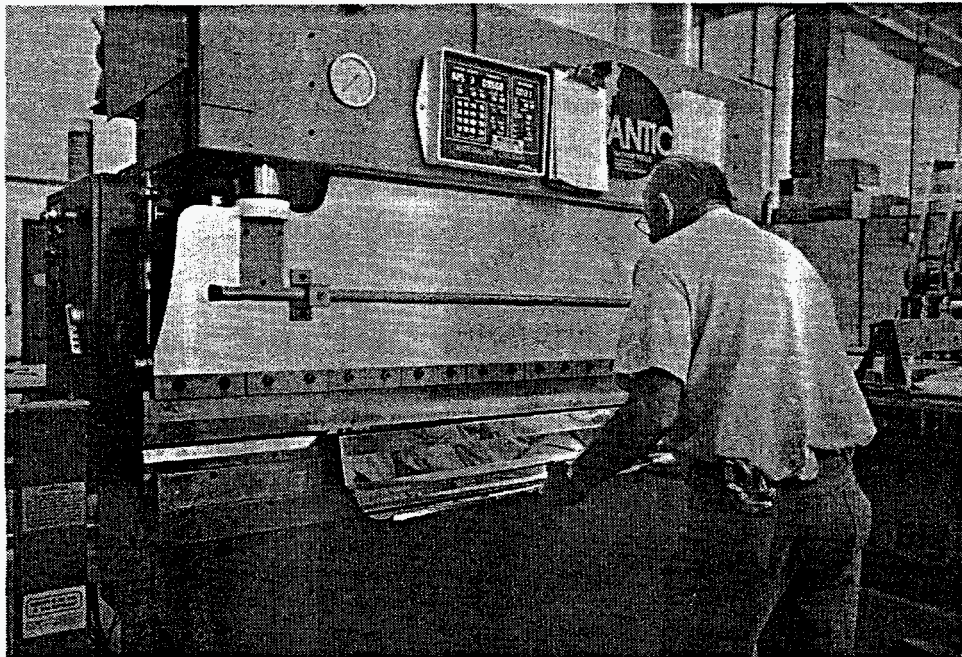

Figure 2.11 Press Brake Being Used for Fabrication of Aluminum Module Housing

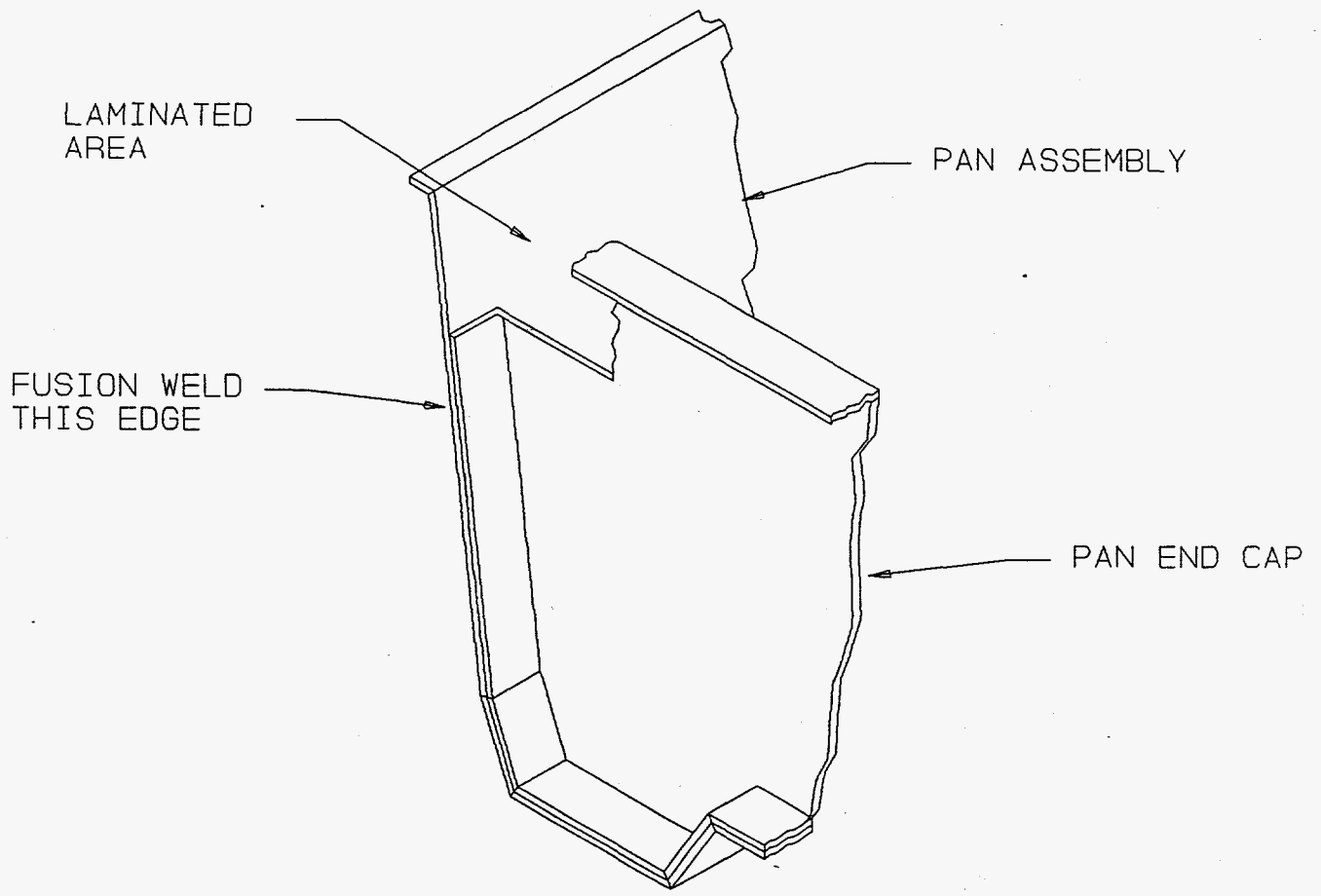

Figure 2.12 Current Pan and End Cap Assembly

Electrical Interconnects

The electrical interconnects are made from flat copper coil stock. There are six different types of interconnects. Some require a hole to be punched in one end to mate with the diodes. Some have right angle folds and several have expansion stress relieving loops in them (see Figure 2.13). These operations are performed on single station presses. Punching tooling is standard. The loop bending tooling is custom made for this operation.

Where the ends of the interconnects are to be soldered the specific areas are etched, rinsed and pretinned.

Receiver Assembly

The first step in receiver assembly is aligning the housing pan in the assembly fixture. This alignment is important to assure that the cells are positioned where the lens foci will be. Adhesive is dispensed onto the pan where the cell assemblies will go. A placement fixture positions the cell assemblies correctly and applies pressure to the assemblies during the adhesive cure.

Ceramic pads are fastened with the same adhesive to the housing pan where the electrical interconnect's expansion loops will be located. These pads ensure long-term electrical isolation of the interconnect from the housing pan.

The pan is removed from the fixture and moved to the interconnect installation station. The diode mounts are installed using the same adhesive as the cell assemblies and insulation pads. Interconnects are installed according to the appropriate circuit pattern. The interconnects are all soldered at both ends to ensure long-term connection integrity. Since all mating parts for soldering are pretinned, the joints only require brief reflow at each joint.

An electrical test of each assembly is done at this time to ensure correct diode and interconnect installation. An insulation standoff test is also conducted on each module.

The receiver assembly process comprises placing the cell assemblies and diode assemblies in the module pan and then attaching the electrical interconnects. Workstation 2 performs the assembly placement while workstation 3 installs the electrical interconnects. Robots will be used to place and bond the cell and diode assemblies in the pan. An estimated cycle for this workstation is shown below.

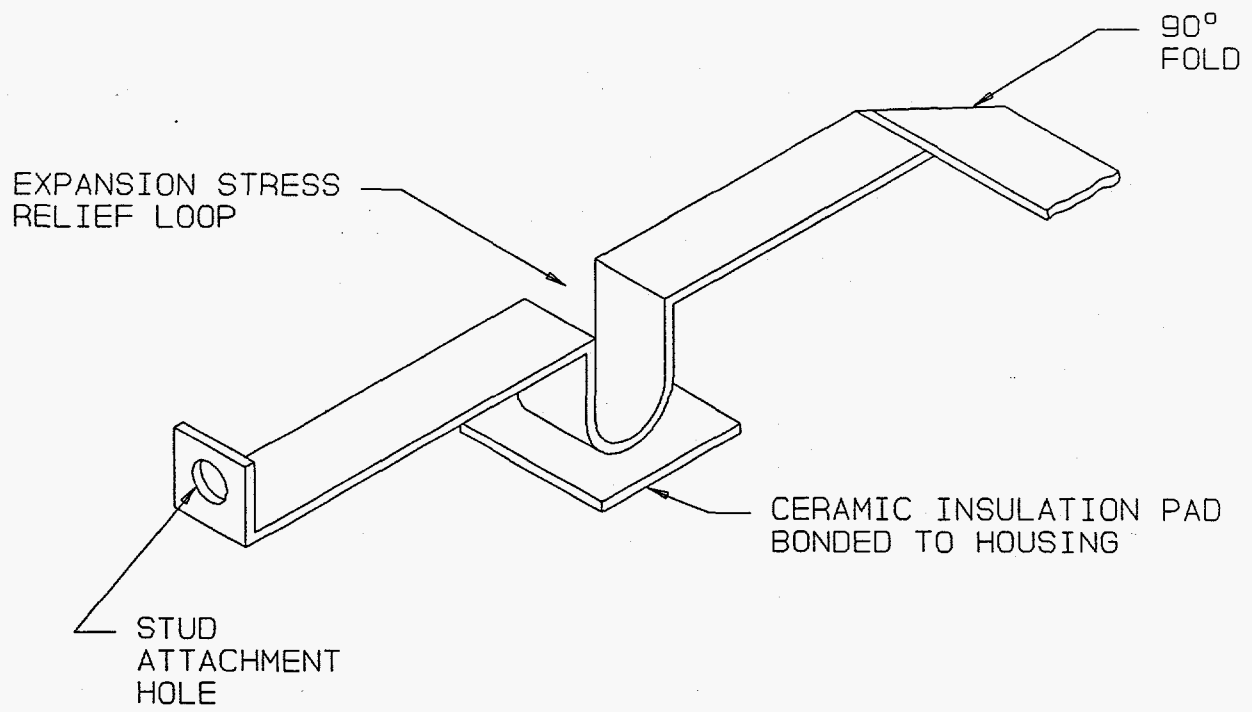

Figure 2.13 Typical Electrical Interconnect Features

Operation:	Receiver assembly	Hr/Pc	Pc/Hr
Oper. #	Operation		
10	Align pan assembly	0.0167	60
11	Adhesive dispense (27x)	0.0375	27
12	Place cell (24x), diodes (3x)	0.0750	13
13	Place holding fixture	0.0833	12
14	Remove fixture	0.0042	240
Process time at workstation 2 for 1 module		0.2146	4.62

The estimated cycle time of interconnect installation is as follows. The estimated cycle time of interconnect installation is as follows.

Operation:	Electrical interconnect installation	Hr/Pc	Pc/Hr
Oper. #	Operation		
20	Flux/Ass/Solder SS interconnect (12x)	0.500	20
21	Flux/Ass/Solder LS interconnect (10x)	0.0417	24
22	Flux/Ass/Solder SS interconnect (3x)	0.0125	80
23	Flux/Ass/Solder LS interconnect (1x)	0.0042	240
24	Flux/Ass/Solder SS interconnect (2x)	0.0083	120
25	Flux/Ass/Solder LS interconnect (2x)	0.0083	120
Process time at workstation 3 for 1 module		0.1250	8.0

Module Assembly

The module assembly includes the receiver assembly just described plus the lenses and lens mounting hardware. This hardware includes edge clip and lens partition extrusions plus tape and sealant. This assembly is the last step of module manufacture. This sequence is diagrammed in Figure 2.14.

Lens Partition Clips

The lens partition is an aluminum extrusion. When installed it performs two primary functions. It supports and seals the two adjacent edges of neighboring lens parquets. It also reinforces the module housing against cross sectional distortion because it is fastened as a span across the open side of the module housing.

The extruded cross section with a receiving slot on two sides allows the first function to be accomplished. The second function can only be accomplished when each end of the partition clip is securely fastened to the housing edge. Each end of the clip is drilled and then machined to have a contour which closely matches the housing contour.

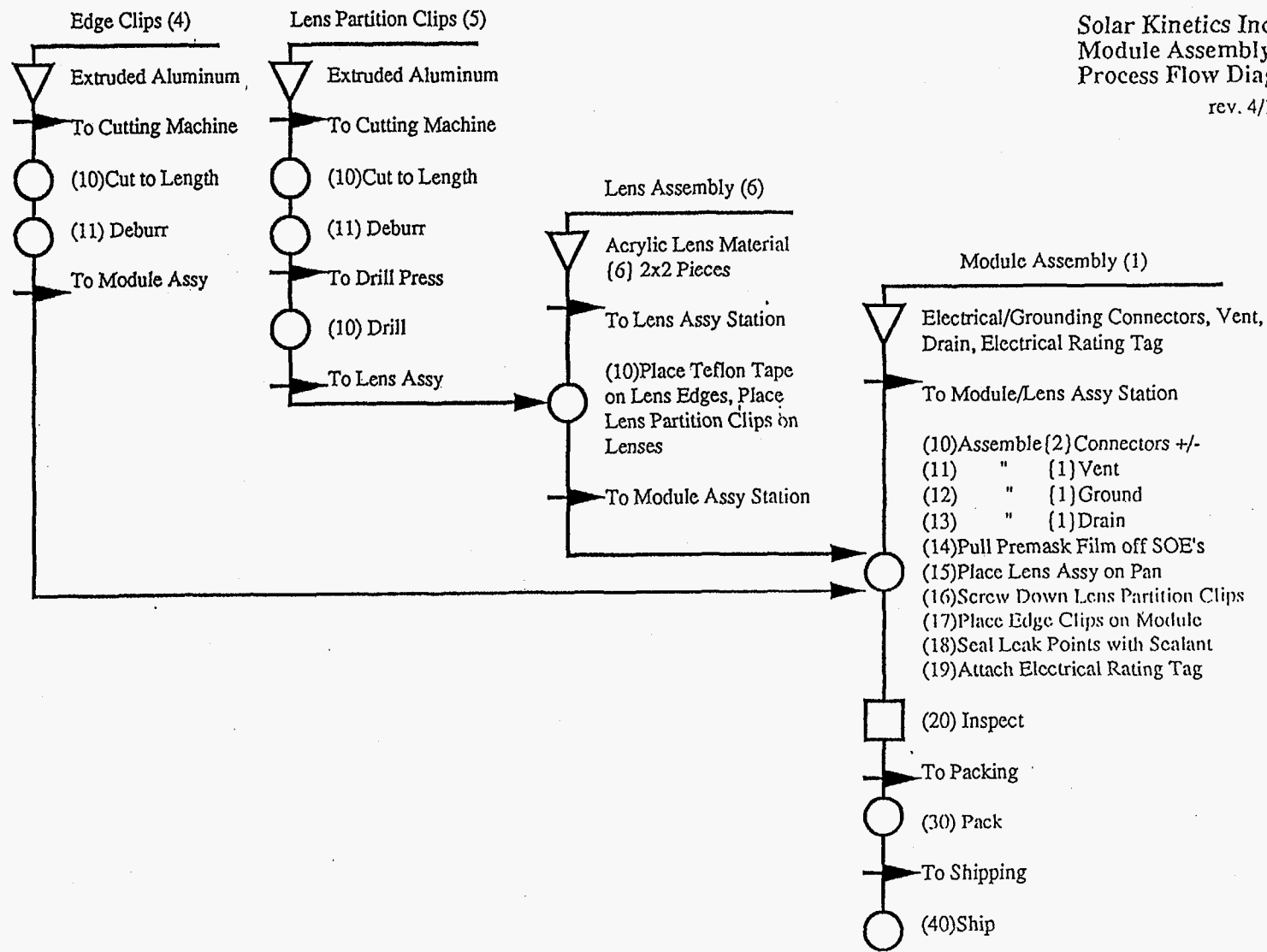

2-24

Figure 2.14 Module Assembly Process Flow Diagram.

The edge clip extrusion is first cut to length. The ends are then milled on a dedicated set up on a vertical milling machine.

Lens Assembly

Lenses are currently received as single units. The edges of four lenses are trimmed on two adjacent sides to remove the flat outer perimeter. The trimmed edges are then solvent fused to one another to form a 2x2 parquet of four lenses. It is anticipated that future lenses will be received as 2x2 parquets.

The 2x2 parquet has a flat unfaceted perimeter edge. Teflon tape with pressure sensitive adhesive is applied to the rear side of this edge. Partition edge clips are used to attached 6 parquets together to form a 2x12 lens assembly.

Edge Clips

The edge clips are made from a custom aluminum extrusion. The extrusion is received in 12 feet or longer lengths. The first operation is to cut the side and end clips to length. This is done on a band saw. The ends are then miter cut to join smoothly at the module corners. The cut edges are manually deburred before transfer to the next operation.

Module Assembly

The first step of module assembly is to install all through housing fittings such as the grounding connectors, vent fitting and drain. The electrical rating tag is attached with pressure sensitive adhesive so no unnecessary holes are made in the housing.

The protective premask film in the SOEs is pulled off.

The lens assembly consisting of 6 parquets assembled with edge clips is positioned on the housing pan. The lens partition clips are fastened in place with self drilling and self tapping screws. The edge clips are installed next around the entire lens perimeter. No fasteners are needed to retain the edge clips. Silicone RTV sealant is applied in the corners and where the edge and perimeter clips meet.

After a final inspection the modules are packed for shipping.

Rear Structure

The rear structure assembly is very conventional. A custom jig is used to hold the truss members in correct alignment during welding. Welding is accomplished efficiently by hand for initial production volume. When volume justifies it, the same jigs can probably be used in a semi-automatic welding operation. A worker will load the individual parts into the jig, securing each one with a preinstalled clamp. The jig is then shuttled into a welding station where a robotic welder welds all the joints to the required specifications.

Hot dip galvanizing is performed by an outside vendor who specializes in this coating. The equipment is not worth investing in for the relatively low volume of parts requiring coating.

Tracker Control

The manufacturing steps associated with the tracker control are primarily electrical wiring and assembly. A standard electrical enclosure will house the PLC. The internal wiring of the panel will be done point to point in initial low volumes. A wiring harness may be built later when assembly volume increases. This harness could be fabricated by SKI or an independent contractor. Use of a harness should include the sensor-to-enclosure wiring to significantly reduce field wiring effort.

Programming the PLC is very simple in production by down loading the standardized software from an EEPROM.

3.0 PROPOSED PROCESS AND DESIGN IMPROVEMENTS

Concentrating PV modules and arrays must compete with both conventional energy sources and other renewable energy sources to establish a viable commercial market. While there may be other intrinsically valuable reasons for using an energy source which doesn't consume fossil fuels or generate any emissions during operation, the primary motivation for most buyers will be the cost. The emphasis of all efforts to commercialize concentrating PV technologies must be to provide the lowest possible delivered levelized energy cost (LEC).

To minimize the LEC, PV module manufacture will require the economies of large scale automated production. Both process and product design must focus on designing for automation and designing for lowest life cycle costing. This is not the same as designing for lowest material cost or lowest installed cost or lowest gross weight.

The following discussion will cover both proposed design changes to the product and the processes used to manufacture it. The general philosophy followed is to consider alternate materials which eliminate a processing step without an offsetting increase in material cost. Changing processes to allow more efficient automation is an essential approach. Manual processing methods are not typically adaptable to automation. Much developmental work done to date has involved manual operations because of its low volume or prototypical nature. Now that many critical processes and components have been demonstrated, this manual orientation must be replaced with designing for automation.

In the interim period while technical details and module performance continues to be developed the existing design will be produced using existing tools and practices. The new materials identified as appropriate for large volume production will be introduced into the existing design and proven. Design changes implemented for automation will also be proven in this lower volume approach. Initial niche markets will be addressed with the lower volume approach while full automation is developed.

3.1 Review of Current Fresnel Lens Manufacturing Processes

As part of the current effort, SKI evaluated the current state of development of concentrator module lenses and reviewed a wide range of possible alternative manufacturing processes. As part of other on going PV module development work, SKI had already reviewed available lenses and determined that for cost and performance reasons, a new lens design was desirable for the SKI concentrating module.

SKI chose to take the initiative in designing its own lens and developing its own lens vendor for various reasons. Over the past 6 years Sandia National Laboratories at Albuquerque (SNLA) and Electric Power Research Institute (EPRI) have

established that high efficiency Fresnel lenses (80%) can be molded by various molding techniques including compression molding, 3M's film Polymeric Web process, and injection molding. Table 3.1 summarizes the development history of various point focus fresnel lenses. The primary material used has been an optical grade polymethyl metacrylate (PMMA), commonly called Acrylic.

Compression molding has given highest efficiency lenses, but the process is cost prohibitive in view of the DOE's cost goals of \$35 per square meter under current large quantity cost projections. Compression molding generally has been a slow process typically used for high precision parts. Because of the slow processing rates the part costs are high. Typically, each cycle takes approximately one half an hour.

The proprietary process used by 3M corporation is called the Polymeric Web^{[2][3]} process. This seems to be some type of hot rolling/extrusion process applicable to thin acrylic sheets. This process has been under development for about ten years. After the film is made it needs to be laminated onto a transparent substrate (acrylic) as its thickness is only 0.022" and is not self supporting. One company has invested substantial effort and funds into utilization of such a film in their point focus PV module. This company has also indicated that they will consider use of a molded lens in the future. One significant problem that we anticipate is the obtaining of required tolerance in the layout of the individual lenses in the parquet. This leads to improper positioning of the point focus lenses with respect to the PV cell assemblies. Also, the lens film technology does not meet the DOE cost goals.

An injection molding process has been developed by American Optical Corporation over the years. The process has shown excellent promise, and has lately delivered 80% transmission efficiency. This performance is comparable to compression molding, but by injection molding the lens can be made at fraction of the cost. Progress under a current contract for this lens development has been slow. SNLA has been working with American Optical Corporation for about 6 to 8 years. The starting point for this work was the tooling and technical achievements of the compression molding process. In our opinion the progress in the development work of these injection molded lenses has been too slow. We are of the opinion that an injection molding vendor needs to be identified who has the appropriate technical capability and high volume molding capacity with fast turn around capability.

Manufacturing with Acrylic

Investigating the fabrication of the fresnel lens from acrylic (PMMA) was directed to two main areas. These were how acrylic is produced for stock material and how acrylic parts are manufactured from this stock material. In addressing these issues, consideration of the lens specifications and costs were considered in order that an appropriate process could be identified. Finally, alternate materials were considered in determining if the fresnel lens could be manufactured in a more cost effective manner than if produced from acrylic.

TABLE 3.1

POINT-FOCUS FRESNEL LENS WORK LIST TO DATE
 DEMENSIONS IN INCHES

APPLICATION	DESIGNER	LENS SIZE	FACET	SIZE/SHAPE	L/C SP	IMAGE SIZE	CG	FAB. PROCESS	PARQUET	COMMENTS	MFG.
ALPHA SOLARCO	JAMES	8.35 SQ	0.03	WIDE FLAT	11.393	0.492 SQ	288	3M DIRECT CUT	SINGLE	FACET WIDTH SIMULATED	3M
ALPHA SOLARCO	JAMES	8.35 SQ	0.03	WIDE FLAT	11.393	0.492 SQ	288	3M DIRECT CUT	SINGLE	FACET WIDTH SIMULATED	3M
ALPHA SOLARCO	JAMES	9.00 SQ	0.03	WIDE FLAT	11.393	0.492 SQ	335	3M POLY WEB	2 X 12	FACET WIDTH SIMULATED	3M
APS AIRPORT	OSG (3M)	12.00 SQ	0.05	WIDE FLAT	14.125	1.91 DIA	39	COMP MOLDED	1 X 4	2.17 DIA CELL System By Martin Marietta	OSG (3M)
BLACK & VEATCH	GE	6.65 SQ	0.03	WIDE FLAT	8.05	0.488 SQ	188	COMP MOLDED	4 X 6	Made from 5 x 6 SBMII	FO
EPRI	B & V	7.00 SQ	0.03	WIDE FLAT	11.14	0.314 SQ	500	COMP MOLDED	4 X 6		FO
INTERSOL POWER	FO	8.16 SQ	0.02	WIDE FLAT	9.25	0.696 SQ	84	COMP MOLDED	2 X 7	0.89 SQ CELL (Metal SOE added later)	FO
INTERSOL POWER	3M	8.16 SQ	0.03	WIDE FLAT	9.125	0.68 DIA	183	POLY WEB	2 X 7	FACET WIDTH SIMULATED	3M
INTERSOL POWER GaAs	JAMES	8.16 SQ	0.04	WIDE FLAT	10.7	0.287 DIA	1030	COMP MOLDED	SINGLE	2 X 7 PARQUET PLANNED	FO
MARTIN MARIETTA	FO	8.16 SQ	0.02	WIDE FLAT	9.25	0.696 SQ	84	COMP MOLDED	2 X 7	0.89 SQ CELL	FO
SBMI	SWEDLOW	6.70 SQ	0.025	WIDE FLAT	7.37	0.863 DIA	157	CAST	1 X 5	1.0 DIA CELL	SWEDLOW
SBMII	GE	6.65 SQ	0.03	WIDE FLAT	8.0	0.61 DIA	154	COMP MOLDED	5 X 6	SINGLE LENS ALSO	FO
SBMII	GE	6.65 SQ	0.03	WIDE FLAT	8.0	0.61 DIA	87	COMP MOLDED	5 X 6	0.81 DIA CELL w/o SOE	FO
SBMII	3M	6.70 SQ	0.015	WIDE FLAT	8.0	0.61 DIA	154	POLY WEB	5 X 6	SBMII OPTICAL DESIGN	3M
SBMII	AO	6.70 SQ	0.12	DEEP CURVED	8.0	0.61 DIA	154	INJ MOLDED	SINGLE	Made from 5 x 6 SBMII	AO
SBMIII	GE	6.65 SQ	0.03	WIDE FLAT	8.0	0.492 SQ	183	COMP MOLDED	2 X 12	PARQUET	FO
SMBIV	SNLA	6.82 SQ	0.05	WIDE FLAT	10.0	0.394 SQ	300	NONE	NONE	COMPUTER DESIGN ONLY	NEVER MADE
SMBIV	POC	6.82 SQ	0.12	DEEP CURVED	10.0	0.394 SQ	300	INJ MOLDED	SINGLE	DESIGN PROG AO-SBM4	AO
SLA200X	SNLA	4.92 SQ	0.03	WIDE FLAT	6.0	0.394 SQ	200	COMP MOLDED	SINGLE	2 X 5 MODULE	FO
5LA500X GaAs	SNLA	4.00 SQ	0.03	WIDE FLAT	9.92	0.20 DIA	500	COMP MOLDED	SINGLE	SIEGAL MODULE	FO
SOLERAS	OSG (3M)	12.00 SQ	0.05	WIDE FLAT	14.12	1.91 DIA	39	COMP MOLDED	1 X 4	2.17 DIA CELL System by Martin Marietta	OSG (3M)
SOLAR KINETICS		6.82 SQ	0.12	DEEP CURVED	10.0	0.394 SQ	282	INJ MOLDED	SINGLE	DESIGN PROG AOSBM4	AO
VARIAN 1KX	VARIAN	7.00 SQ	0.05103	WIDE FLAT	12.20	0.25 DIA	1000	COMP MOLDED	6 X 6	GaAs CELLS	FO
VARIAN 400X	VARIAN	10.60 HEX (SIDE)	0.06	DEEP CURVED	12.88	0.49 DIA	377	COMP MOLDED	SINGLE	3 X 4 MODULE ALDAs/GaAs CELLS	OSG (3M)
VARIAN BEAMSLITTER	VARIAN	6.90 HEX. (SIDE)	0.06	DEEP CURVED	30.5	0.333 DIA	390	COMP MOLDED	SINGLE	2 X 5 MODULE Si & GaAs	OSG (3M)
VARIAN 1 PC TRK	VARIAN	5.44 SQ	.05094	WIDE FLAT	10.2	0.20 DIA	942	COMP MOLDED	SINGLE	3 X 11 MODULE GaAs CELLS	FO

- FO – Fresnel Optics, Inc.
- AO – American Optical, Inc.
- OSG – Now is 3M Corp.
- CG – Concentration-Geometric
- L/C SP – Lens to Cell Spacing

Acrylic flat stock material is produced by using one of three main methods. These are calendering, casting, and extrusion. Calendering utilizes an arrangement of high speed rolls. Casting can be realized by either a batch process using molds or continuously processed between stainless steel belts. Extrusion consists of forcing a continuous uniform melt through a die to obtain the desired sheet profile. Each process has its merits and recommendations for specific manufacturing techniques.

As mentioned above, calendering uses an arrangement of high speed rolls that is used in producing sheet from .05mm (.00197in) to 1mm (.03937in). These rolls are highly machined components for the control of surface finish, roll eccentricity, and barrel profile. There is also a need to have close control over the roll temperatures, speeds, and roll proximity to one another. Since this is a continuous process, cycle times are not a factor. But this process can not accommodate the required .250 in. thicknesses required by the Fresnel lens. Furthermore, this technique is not a recognized method for producing acrylic sheet. 80% of calendering is used in the production of rigid flexible poly vinyl chloride (PVC).

Cast sheet is made either by a batch process within a mold/cell or continuously between belts. Each of these casting methods has advantages over the other. Cell cast sheet has superior optical properties, light transmittance, and smoother surfaces than continuously cast sheet. It can also achieve a greater thickness. Continuously cast sheets are limited to a maximum thickness of .375 in. However, cell casting has an extremely long cycle time on the order of 12 to 16 hours for a 1/8 in. thick sheet.

Further, continuous casting provides a more uniform thickness and has less tendency to warp. The casting of acrylic products is abundant with most applications in the display, furniture, and glazing industries.

Extruding acrylic sheet requires that a continuous uniform melt (most thermoplastics) be forced through a die and cooled back to its solid state. This take-off equipment requires highly polished rolls with good control to insure the production of quality acrylic sheet. Sheet products produced from this technique are typically made in widths up to 120 in. and thicknesses up to 1/2 in. Extruded sheet is highly recommended when thermoforming intricately detailed parts.

As with the production of acrylic sheet the fabrication of acrylic parts is mostly done by one of three processes. These are compression molding, injection molding, and thermoforming. Compression molding has been the proven method for forming acrylic fresnel lenses. Almost all commercial point-focus fresnel lenses are made by this process. However, due to its long cooling times this method has high relative production costs.

Injection molding acrylics requires higher injection pressures than other thermoplastics. The cost of injection molding can be offset by using specific injection molding acrylic formulations and the inherent quick cycle times between individual components. One minute cycle times achieving facet tips and facet radii of .004 in. or

less have been documented. Finally, thermoforming offers a variety of techniques in forming thermoplastic components. Of these the "match mold" method claims to have both excellent reproductions of mold details and good dimensional accuracy. However, the cooling times and associated costs are comparable to compression molding. Further, the ability of this technique to produce the required lens within the required tolerances is doubtful.

Lens Manufacture by Injection Molding

Injection molding appeared to offer the best potential for producing low cost high quality acrylic lenses. To maintain adequate quality several technical issues needed to be addressed. These included parquet flatness and facet tip and facet valley radii.

Warpage of the parquets prior to installation results in less than optimum focus of the incident flux on the cells. Some nominal tolerance for flatness must be allowed to compensate for manufacturing variations, but this should be minimized. The warpage of a parquet during molding is controlled by several process variables. Warpage is caused by internal stresses in the plastic after it is cooled in the mold. These stresses can result from the rate of cooling after the mold is filled. They can also result from viscous flow stresses in the acrylic melt as it is forced into the mold. A more viscous compound will require higher pressures to force it into the mold and will have higher residual stresses upon cooling. The melt viscosity is a function of the plastic compound and the injection temperature. Mold temperature and rate of injection also effect the viscous forces. If the entire mold is filled from a single point the material must flow farther inside the mold cavity which also leads to higher stresses in the part.

To minimize stresses and therefore part warpage the process should allow longer cooling cycles, use a warmer mold and use multiple injection ports. Unfortunately the first two requirements lead to longer cycle times and the third requirement increases mold costs, all leading toward higher part costs.

The facet tip is the edge where the sloped ring of the facet face ends forming the familiar saw tooth cross-section of a fresnel lens. The valley radius is the radius found at the root of each facet where the material turns to form the back side of each facet. At the facet tip and valley radii, the facet contour varies from the perfect theoretical facet shape. Light rays passing through the areas where the radii exist are not refracted as they should be. Some of these rays merely strike the cell in a different location. Other rays miss the cell entirely. The longer the radii, the greater an area of the lens is effected.

An ideal facet would have infinitely small tip and valley radii. An actual molded part has some radius at this point because of the way the plastic melt flows into the mold and the way the mold is manufactured. Generally the mold can be manufactured with smaller radii than the acrylic can reproduce. The viscosity of the acrylic melt causes a microscopic bridging across the valleys of the mold. Also air trapped in the

mold is in-turn trapped between the plastic melt and the mold surface in the bottom of the mold valleys. This cushion of air prevents the melt from fully filling the mold contours and therefore increases the molded parts radii. This effect can be minimized by drawing a vacuum in the mold to remove as much air as possible. Location of the vacuum ports can assist what residual air is left from being trapped by the advancing melt and compromising the mold contour repetition.

Manufacturing a lens with greater tip and valley radii, all other things being equal, would reduce the lens cost, since special provisions for minimizing tip and valley radii make the lens cost more. However, longer radii mean the lens is less efficient, which means the lens must be bigger and heavier to provide the same energy to the cell. This means the modules and the support structure must be larger to accommodate the increased weight and larger wind loads.

The significance of facet tip and valley radii is demonstrated in Figure 3.1 where the variation in energy transmitted by the lens is plotted against radii.

The primary driver for this lens design is to lower the cost of manufacturing these lens parquets. One stringent specification has been the tip and valley radii of the facets. The current philosophy is to have this radii as small as possible (2 mil), so as to minimize the corresponding areas which lead to refractive losses. The resulting tolerance requires highly precise tooling, and long processing times to allow for flow of the material and cooling. Figure 3.1 show an average solar flux (in suns) as a function of tip and valley radii for fresnel lenses of different sizes. It can be seen from this design data that we relax the tip/valley radii requirement substantially if we increase the lens size by a fraction of an inch, and still maintain the same average solar flux on the PV cell. This strategy will lower the processing requirements and thus costs substantially, with minimal increase in material cost.

Lens Material Alternatives

Another method of controlling part quality is to change the molding material to reduce internal stress generated during molding and cooling. A material with a lower viscosity would fill the mold more easily with less pressure drop and lower internal stress. Also a material with a lower thermal coefficient of expansion would tend to change shape less during cooling and therefore develop less internal stress.

Several compounds of acrylic have been formulated to achieve this. One such compound is a modified acrylic resin manufactured by a large plastics raw material supplier. This family of new specialty thermoplastics is based on chemistry differing from any currently available plastic. They exhibit an attractive balance of features including high heat resistance, excellent optical transmission, outdoor durability, superior vapor barrier, excellent stiffness and ease of processing. These plastics are newly introduced for the lighting, automotive, optical and packaging markets currently. Some of the properties that are key to fresnel lenses, namely, high heat resistant, low coefficient of thermal expansion, high refractive index, excellent clarity,

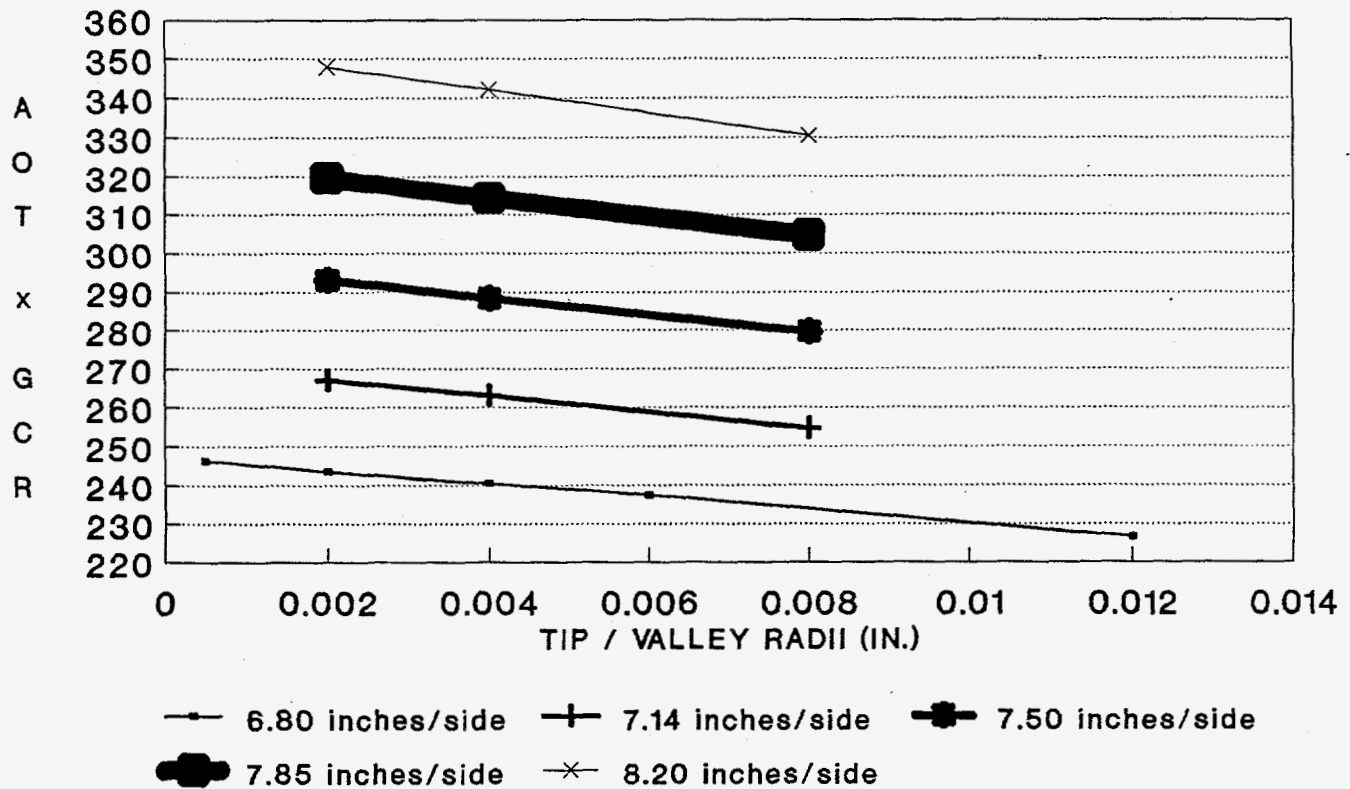

A.O.T. = Average Optical Transmission
 G. C.R. = Geometric Concentration Ratio
 A.O.T. X G.C.R. = Average Solar Flux on Cell

Figure 3.1 Fresnel Lens Design Strategy for Low-Cost Manufacturing

low haze and thermal stability, are also met by this plastic. For proprietary reason, we are not disclosing the specifics of this optical grade plastic. Specially tailored optical grades of this plastic have the potential to improve the economics and part-to-part variability in complex designs as required for point focus fresnel lenses. Some of the relevant properties of this class of materials is presented in Table 3.2. These materials are appropriate for injection molding.

In comparing other polymers with acrylics for possible use in fabricating the lens, one appeared to have both equivalent optical properties and superior processing properties. This thermoplastic was crystal polystyrene. It has equivalent optical properties to acrylic except that its light transmittance is approximately 2% lower. The lower optical performance possibly could be traded for the resin's ease of injection molding and low material cost. Crystal polystyrene's incompatibility with this project is because its UV stability is low as compared to acrylic. Acrylic formulations with UV stabilizers maintain their optical and strength properties for approximately 20 years while the best UV stabilized crystal polystyrene can withstand only 1 year of exposure before serious property degradation starts. Thus, we conclude that acrylic or its modified forms are the current materials of choice for molding of point focus fresnel lenses for PV applications.

Proposed Molded Lens Design

Early in the current effort it was recognized that the preferred lens parquet configuration would be 2x2. Successful molding of a larger parquet than this could not be assured by the vendors. The press required would be very large. The cycle time would be long to assure cooling of the melt without part warpage. Long cycle times on a large expensive machine leads to expensive parts. The development of the tooling would also be fraught with higher technical and financial risk because of its size. A preliminary specification for the smaller parquet, therefore, was developed based upon the successful American Optical part currently being used. All future references to the current design assume the use of the 2x2 parquet. Specifications are listed in Table 3.3.

Table 3.2
AVERAGE PHYSICAL PROPERTIES OF RESINS

PROPERTY	ASTM TEST METHOD	UNITS	GRADE 1	GRADE 2	GRADE 3	GRADE 4
OPTICAL PROPERTIES						
Refractive Index	D-542	—	1.53	1.54	1.53	1.54
Light Transmission	D-1003	%	90	90	90	90
Haze	D-1003	%	2.0	2.0	2.0	2.0
Spectral Gloss at 60°	D-523	%	98	98	98	98
THERMAL PROPERTIES						
Melt Flow Condition J (509°F/27.5 lb.)	D-1238	gm./10 min.	16	7	20	11
Glass Transition Temperature	D-3418	°F	300	335	290	320
Continuous Service Temperature Range	—	°F	255-275	300-320	245-265	275-295
Coefficient of: Linear (-40°F) Thermal (73°F) Expansion (194°F)	D-696	in./in./°F x 10 ⁻⁵	2.3 2.9 3.2	2.2 2.6 3.2	2.4 2.9 3.7	2.2 2.7 3.3
Coefficient of Thermal Conductivity	C-177	BTU-in./ hr.(°F)(Ft ²)	1.02	1.02	1.02	1.02
Specific Heat	C-351	BTU/lb. °F	0.34	0.33	0.34	0.33
MECHANICAL PROPERTIES						
TENSILE STRENGTH						
Strength @ Break	D-638 (0.2 in./min.)	psi	11,200	11,500	11,200	11,500
Elongation @ Break		%	4.00	4.00	4.00	4.00
Modulus of Elasticity		psi	620,000	620,000	520,000	575,000
COMPRESSIVE STRENGTH						
Strength @ 10% Deflection	D-695 (0.05 in./min.)	psi	18,000	18,500	18,000	18,200
Modulus of Elasticity		psi	530,00	550,000	530,000	550,000
Tensile Impact	D-1822	ft. lb./in ²	20	20	20	20
MISCELLANEOUS PROPERTIES						
Specific Gravity	D-792	—	1.21	1.22	1.21	1.21
Hardness, Rockwell	D-785	M-Scale	98	100	98	100
Mold Shrinkage	D-955	mils./in.	3-6	3-6	3-6	3-6
Water Absorption Weight Gain After 24-hr. Immersion	D-570	%	0.30	0.40	0.20	0.25
Water Absorption Weight Gain After Equilibrium at 73°F/50% R.H.	—	%	1.50	1.90	1.20	1.25
Water Vapor Transmission @ 37.5°C, 100% RH	—	(g-mil) 100 in ² -day	4.6	4.7	4.7	5.3

TABLE 3.3

PRELIMINARY LENS SPECIFICATION

Configuration:

Preferred configuration will be a 14" x 14" lens panel containing four (4) distinct square lenses arranged 2 x 2 (2 per side).

The lenses are of constant nominal thickness. One side is completely flat. On the opposite side each individual lens is made up of concentric rings of diminishing width. All rings or facets are the same height.

Facet Surface Shapes:

The primary facet surfaces are compound curves. They do not form sections of a cone but rather sections of a sphere. The width of each facet ring is varying, with the smaller diameter rings having greater radial widths.

Maintaining the correct contour of the lens facet surfaces has been the second largest source of part rejects in past production.

Flatness:

0.015" - 0.020" in 14" span.

This specification has been the major cause of previous lens's high reject rates. This has been the largest problem even in single lens panels, 7" x 7".

Draft angle:

The inner face of each facet is not curved. It is simply given enough draft to allow removal from the mold.

Draft angle: 2 degrees (\pm 1/2 degree)

Tip and valley radii:

0.001" - 0.002" radii

Previous mold makers found use of a 0.0005" radii diamond tool necessary to obtain these radii.

Surface finish:

8 micro-inch

Previous mold makers found best results with a 0.002 in. radii tool tip. Small feed rates of about 0.0001"/revolution were used.

SKI is able to develop a lens design optimized for a given cell and anticipated manufacturing techniques. Analysis is used to select design features which offer high performance within the manufacturing tolerances for the module components, assembly and support structure. Performance can then be predicted under operational conditions to verify effects of the balance of the array system. The lens design is then iterated to achieve an optimized system which will offer continued cost effective performance through out its life cycle.

Solar Kinetics uses computer-aided optimization of Fresnel lenses and photovoltaic concentrators for the module design. Capabilities extend to virtually every component of the module. Presently, this commercially available software is applied to curved-groove Fresnel lenses used in conjunction with a reflective secondary element. The software code can also simulate flat-groove lenses as well as refractive secondary elements.

The software uses a ray trace approach. It considers the effects of the module components specific geometry on incident light rays from a selected theoretical sun shape. It accounts for indices of reflection and refraction, transmissivity and reflexivity of the lens and secondary optical element. It also accounts for the specific dependency of these different properties on wavelength and the relative energy available in the solar spectrum at the various wavelengths. The Monte Carlo integration technique is used for ray tracing. This statistical approach for simulating the model uses a random number generator to create a synthetic data set for the sun's rays. The program then traces each individual ray through the lens and ultimately onto the cell. The accuracy of the simulation depends on the number of rays to be traced. As the time to run the program varies for the number of rays, a range of 800 to over 3×10^6 rays can be chosen. However, the results contain statistical noise which is reduced roughly as the square root of the number of rays. Typically, this error is within 5 percent for approximately 2×10^5 rays.

The software is extremely helpful not only in the initial design of the lens and module, but in determining allowable manufacturing tolerances. Therefore, a "design-for-manufacturing" approach can be taken early in the design phase for significant cost savings in the manufacturing phase. In the Solar Kinetics photovoltaic concentrator module, defining lens facet tip and valley radii, tracker error, and cell placement tolerances has been critical to the module design. Using the solar cell output as a design parameter, effects of input parameters on cell output can accurately illustrate how manufacturing tolerances will affect module efficiency.

Included in the software package is a solar cell model that can accurately simulate most commercially available cells. This model is used to generate a current vs. voltage curve for the cell. Minor modifications to the program code or input make the software extremely versatile. Lens and secondary optical materials can be changed simply by altering the material properties within specified lines in the code. Cell parameters such as doping levels, quantum efficiency, grid spacing, etc., are defined extensively and modified easily through a series of input statements.

Other software capabilities include a solar cell thermal analysis package. From the outputs of the lens optics software, it is possible to determine thermal flux density at the solar cell level. By defining the heat spreader and cell properties, and using the outputs of the aforementioned software, it is possible to determine approximate temperature levels of the cell and underlying components. This can be accomplished by finite element analysis for sophisticated geometries, or hand-reduction for simpler problems.

Data may be output in several ways. The lens geometries required for manufacturing are put into a table that lists radii and angles. Short circuit current within the cell and thermal flux densities upon the cell can be graphed in two-dimensional contour plots or three-dimensional isometric drawings. All electrical outputs are listed and output to a printer for each individual computer run.

The software has been used extensively in the design of the present photovoltaic concentrator module. Provided the correct cell parameters are input, the software can duplicate field data within 5 percent. Experiments to verify the accuracy of the software have been done at Sandia National Laboratories by using a flat-groove lens with a refractive secondary optical element.

Lens Manufacturing Vendor Investigation

During the past 3 months we had meetings and detailed technical and cost discussions with various large injection molding houses. These companies have been in the molding business for over 50 years with extensive precision optical molding capabilities. The objective was to identify, evaluate, negotiate and select a short list of 3 to 4 companies for final evaluation and selection. We have obtained detailed process, material and cost information from these 3 companies to mold the required point focus lenses in large quantities. It will take them about one year to produce these lenses in large quantities, starting first with tool design, tool development, initial text runs, evaluations and finally quantity production. Currently, we are in the process of designing the lenses parquet for our module to be injection molded for prototyping by one of the selected vendors. We have been quoted 20-25 \$/m² for these point focus fresnel lenses based on optical grade acrylic as the material. The key objective after obtaining acceptable 2x2 lens parquet prototypes will be evaluation of CAD/CIM of such injection molded lens to lower cost even further. These vendors also have experience with a newer optical grade material introduced in a previous section. We have also acquired samples of injection molded fresnel lens made by several of these vendors using the newer optical grade materials. These lenses show excellent tip/valley radii, surface finish and profile qualities.

SKI has done extensive vendor contact for injection molding point focus Fresnel lenses for PV applications. We have received quotations for molding of these lenses from injection molders of optical parts. These molders have extensive facilities and experience in manufacturing large quantities of acrylic lenses (including Fresnel lens) for various applications. Samples given to us for evaluation demonstrate that

they can meet the critical requirements for a point focus Fresnel lens. Also, the cost of injection molding a point focus Fresnel lens as per our design will be less than the DOE cost goal. These quotations are based on a medium quantity order, and the cost will be further reduced for larger quantities.

SKI plans to work with certain injection molding vendors to fabricate these Fresnel lenses at a cost which is only 1.5 times the cost of the virgin acrylic material. The turn around time from order placement to first lens delivery will be about 6 months. This time period allows for new tooling fabrication and try out. This time period allows for new tooling design, development, fabrication and molding of the first set of lens from this tooling. This time period also allows for modification and testing of the tooling if the first set of lenses are not as per specifications.

Lens Market Projections

During the initial phase of vendor contacting a frequent question we were asked was what is the potential market for lens parquets. The companies we were working with are high volume manufacturers. They are very interested in generating business with industries which need large quantities of parts. Although they are precision fabricators and highly qualified engineers, they are in a commodity market. They want to know how many pounds of product they can anticipate producing annually. After the initial part and tooling development, this is what the molding business comes down to. This is the business they are in, not the R&D business. Therefore we performed some quick estimates of the annual volume of lenses required for the SKI projections and for the industry as the DOE sees it.

To make an estimate of the gross lens market potential for the PV industry several assumptions must be made. The DOE's new five year Photovoltaics Program Plan projects anticipated cell efficiency and market size in MegaWatts for the next 40 years (a). We estimated the balance of system efficiencies and the percentage of the PV market met by concentrating modules to derive a very rough potential market estimate. The results are summarized in table 3.4.

The three annual production volumes SKI has considered in the current study require lens production volumes of 240,000, 2,400,000, and 24,000,000 lenses per year for 1, 10, and 100 megawatts of modules per year respectively. This is equivalent to approximately 210,000, 2,100,000 and 21,000,000 pounds of acrylic lenses per year.

Summary

The point focus concentrating fresnel lenses are a critical and important component of a concentrating photovoltaic module. Over the past decade Electric Power Research Institute (EPRI) and Sandia National Laboratory at Albuquerque (SNLA) have invested substantial effort in conjunction with engineering firms and lens/mold makers to obtain overall lens transmission efficiencies of 80%. This transmission has been achieved by various lens making techniques including compression molding, 3M's lens film web process, and injection molding. The primary material used has

been optical grade polymethyl metacrylate (PMMA) or commonly called acrylic. These investigations and efforts have not been pursued to the extent of establishing the manufacturing costs of these fresnel lenses in large quantities. The current DOE goal of obtaining \$35 per square meter has not been demonstrated. Also, we strongly believe that the cost of these lenses can be brought down to \$20 - 25 per square meter. The primary constraint is the material cost. The above prices are based on a lens thickness of 0.59 cm (0.232 inch). This lens thickness is based on the current lens design for injection molded lenses. The current philosophy of lens design is for a lens parquet size of 42" x 14". Qualification test results of various concentrating modules over the years have experienced the change in dimension of the lens parquets after environmental cycling in temperature humidity freeze, though few have been reported. Exhaustive test experience on modules built by SKI have shown this to be an important issue. The approach that SKI proposes is a two fold strategy. First, we plan to use small lens parquets (14" x 14") to minimize the cumulative distortions due to humidity and temperature effects as seen in all acrylic lens. Secondly, we are investigating a modified acrylic (with a monomer) which has half the coefficient of thermal expansion as compared to virgin acrylic.

TABLE 3.4
ESTIMATE OF MARKET FOR PLASTIC FRESNEL LENSES
FOR PHOTOVOLTAIC ELECTRICITY GENERATION.
Based on DOE new 5-year Program Plan

Time Period		1990	Mid-1990's	2010-2030
Utility Power Systems	(MW)* anticipated range average	10-15 12.5	50-100 75	10K-50K 30000
Manufacturing capacity	(MW/yr)*	17.5	75	1000
Concentrating module's market percentage	(%)**	10	25	50
Anticipated efficiency	(%)**	15.5	23	30
Solar insolation	(W/m ²)**	900	900	900
Anticipated lens size	(in./side)**	7	7	7
Lens thickness	(in.)**	0.125	0.125	0.125
Annual lens production	(pcs/yr)** (#/yr)**	389,401 105,120	2,811,688 759,020	57,482,993 15,517,747

* DOE estimate

** SKI estimate

3.2 Proposed Plans For Module Manufacturing

Changes to Cell Assemblies

There are multiple opportunities for reducing costs and designing for automation in the cell assemblies. A general approach is to design small parts, where ever practical, for continuous processing and handling. Forming parts from coil stock instead of sheet stock simplifies handling if the parts are not completely separated until they have to be. When the parts remain linked together like a chain they can be fed continuously from one process to the next. They will not become tangled as loose parts could. Presenting the parts to the final assembly machinery or robot is simplified because all parts will have the same orientation and position.

Heat Spreader

The first part this approach is applied to is the heat spreader. Coil stock would be unwound, leveled and punched, leaving a small tab attaching each spreader to the next. A second punch station will contain a flat punch and anvil for flattening. Tinning of one side may then be accomplished in line with a small wave soldering unit. The completed heat spreader will then be separated from the following part by a small shear. The separate parts are automatically stacked in magazines for in process storage until needed at the assembly station. The magazines will permit simple presentation of the heat spreaders to the assembly robot.

The current process also uses an etching step to prepare the heat spreader for tinning. Elimination of this step by proper selection of fluxes and solder is an immediate goal. This would benefit several operations which currently require etching. Etching must always be followed by rinsing so two steps could be eliminated. Inadequate rinsing could lead to deterioration of the parts being soldered. The spent etchant has a very low pH and contains heavy metals. Disposal and/or treatment of this material is regulated and requires specific treatment and disposal processes. This increases overhead costs by requiring labor, materials and equipment for treatment and disposal as well as extra labor to handle permitting and documentation requirements. The etchant is also highly corrosive. It constitutes a personnel hazard and also a potential corrosion problem for machinery accidentally exposed to it.

Bottom Contact Tab

The bottom contact tab can also be processed from coil stock on a continuous basis. After uncoiling and leveling, the required bend is stamped into the part. Notches will be cut most of the way across the coil in-between parts. The bottom side of the tabs will be pretinned in a small wave soldering machine. These parts will not stack readily once separated into discrete parts. Instead they will be rewound on a large diameter reel. This reel will be transferred to the assembly station. The parts will be unwound and presented to the assembly robot one by one. When the robot grasps the part a coordinated shear will separate the part from the coil and the coil will advance the next part.

The elimination of the etching and rinsing steps needs to be investigated as described previously.

The cost of completely pretinned coil stock should be considered as a means to simplify the contact tab manufacturing. The additional cost of the raw stock may be more than offset by eliminating the etching, rinsing and pretinning operations.

Top Contact

Top contacts will be processed very much like the bottom tabs. Flat copper coil stock will be used. A series of progressive dies will be used to blank out the top contact inside contours and bend the contact fingers down. Wave soldering will pretin the fingers.

To simplify subsequent part handling steps, the parts will remain attached and be recoiled onto reel. A separate ribbon of plastic may need to be interleaved with the metal coil stock to keep the parts separated and avoid tangling and bending the contact fingers. This reel will be transferred to the assembly station to feed the robot there. A shear will again coordinate with the robot to separate the parts as needed.

The elimination of the etching and rinsing steps needs to be investigated as described previously.

The cost of completely pretinned coil stock should be considered as a means to simplify the contact tab manufacturing as described for the bottom contact tab.

SOE Assembly

The SOE assembly is fabricated from polished aluminum coil stock. This material will be purchased in the specific optimum width for SOE fabrication. The flat developed parts would be punched from this strip. As each part is separated from the coil it would be transferred to a custom forming press. Multiple slides would bend all sides up in a single fixture to ensure minimum possibility of mishandling and maintain highest accuracy.

Design changes for this part will include a simpler method of fastening the ends after forming than the current tabs and slots. Ensuring 100% reliable insertion of the tabs into the slots may make the forming operation unnecessarily intricate. One approach is to have a matching tab on either mating edge simply lay against one another. These two tabs may then be spot welded or mechanically staked together.

SOE Mounts

The mounting material is simply double sided foam tape. It is not very well suited to highly automated assembly on three dimensional parts. This is an area where alternative fastening materials or techniques will be investigated. The difficulty associated with the double sided tape is removing the release liner from the tape patch on the SOE when it is ready for final assembly.

One alternative to be investigated would still use foam tape of the single sided variety. The pressure sensitive adhesive would fix the foam to the SOE. At the final assembly station an automatically dispensed anaerobic or other quick acting adhesive would be used to attach the plain foam surface to the top contact.

Solar Cell Assembly

With the cell and heat spreader pretinned the use of separate solder foil at the final assembly may be eliminated. The cell assembly will take place in a custom tooling fixture. The components will be placed by robot in the fixture. There are at least two possible ways to supply the energy to reflow the solder at this point.

One method would have the robot place the entire fixture onto a conveyor which passes through a soldering oven. Temperature and dwell time can be well controlled in this manner. However the entire fixture must be heated which would limit the speed of the process. Also the entire fixture must be moved which introduces the possibility of causing the components to shift position before they are completely soldered. Multiple fixtures will be required so a new cell assembly may be assembled while other assemblies are passing through the oven and cooling.

One method of avoiding some of these problems is to reflow the solder with an inductive heating process. The fixture may be made of materials which do not heat in an inductive energy field. This would decrease the cycle time for this process step and decrease energy usage. Also the fixture would not have to be moved after it was loaded. In this way positive pressure can be exerted on each component to keep it in place during the reflow. Fewer fixtures would be required which would decrease the risk of producing out of tolerance assemblies due to fixture wear or damage.

Changes to Receiver Assembly

There are several design changes in the receiver assembly which would provide more cost effective automation. These design changes allow process changes which will increase process and product reliability and increase cycle speed. Several processes may also be eliminated with the same results.

Pan Assembly

The pan assembly is currently made from sheeted coil stock laminated on one side with an insulating polymer film. Higher production would dictate conversion to a roll forming process. The coil stock would be purchased the specific width required to form the cross section of the pan housing. The coil would still be laminated on the inner surface as a second step. The following step would be to run the coil stock through a roll former. Here a series of specially shaped rollers bends the coil stock longitudinally in a series of steps to assume the cross sectional shape of the pan. This is a standard commercial process used in high speed high volume manufacturing. After roll forming a flying cut off saw separates sections of the material into the required lengths for each pan. Figure 3.2 diagrams this process.

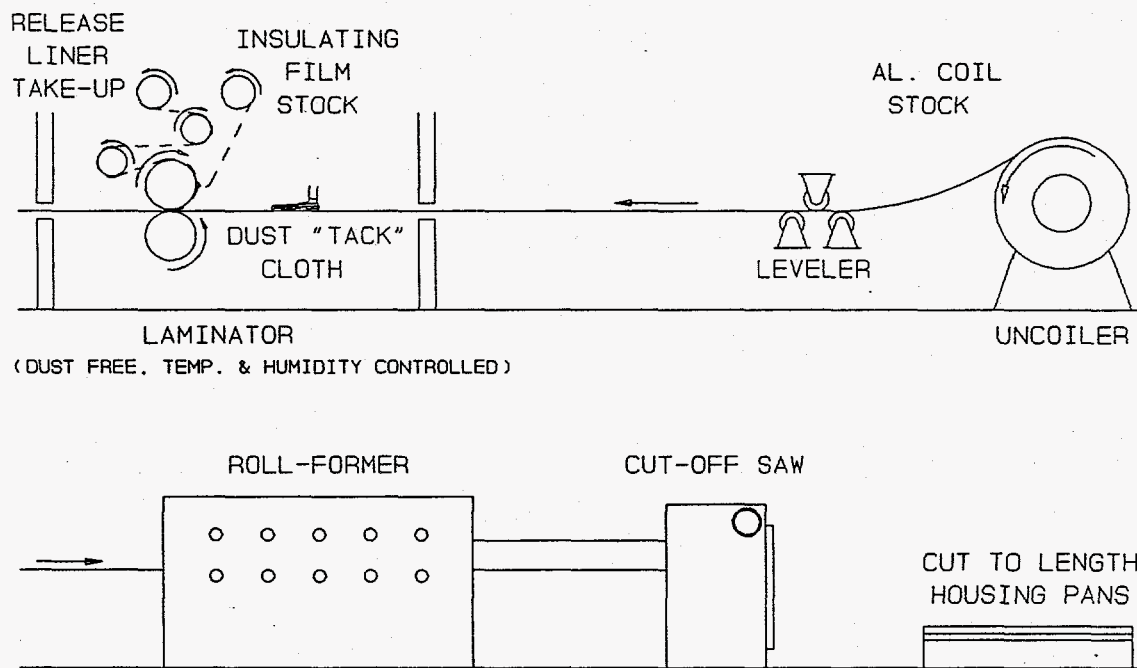

Figure 3.2 Coil Processing Line for Module Housing Pan Production

The cross section of the pan will be slightly modified by increasing corner radii to reduce bearing pressures of the forming rolls on the laminated film and avoid damage to the film. No other changes should be required.

Pan End Caps

The pan end caps will be stamped from prelaminated coil stock. The stamping process may use urethane tooling for the female die to reduce bearing pressures and control wiping actions of the tooling on the laminated film.

Two design changes to the part are likely. Selection of longer radii on the part corners and edges will permit stamping without damaging the laminated film. The part corner's radii must match the radii of the roll formed pan. The lip of the pan end cap will have a reverse bend to allow an improved method of cap attachment to the pan housing. Figure 2.6 and 3.3 show end cap attachment details as currently designed and as proposed.

Elimination of the welding process for pan to end cap attachment will be considered in future development work. Welding requires several special procedures to be implemented to protect the laminated film and to prevent distortion from the heat of welding. Welding also requires higher maintenance equipment and greater quality control efforts than some alternative fastening methods. Specifically, crimping the end cap mechanically to the pan as shown in Figure 3.3 may solve several problems. The crimping is performed by hard tooling requiring very little operator supervision. Unlike welding, it does not require consumables such as shielding gases and tungsten electrodes or periodic routine adjustments such as tungsten sharpening and positioning. Also no preparation of the work pieces is required. The welding operation requires removal of the laminate film from the welding zone and metal surface preparation by solvent and abrasive cleaning. Welding requires temporary placement of cooling media behind the welding zone to avoid distortion and protect the electrical insulating laminate. After welding is complete the cooling media and its residue must be removed and the laminate must be replaced and sealed. This step can also be eliminated by the crimping operation.

The crimping operation can be very fast to help maintain low cycle speeds. The extra thickness of metal at the crimp helps increase stiffness. By crimping two laminated metal surfaces together, continuous integrity of the isolation provided by the lamination can be maintained without an additional sealing operation.

Electrical Interconnects

The electrical interconnect forming tooling is fairly simple. An evaluation is required of the value of forming the parts as required versus pre-forming and stockpiling them. If they are pre-formed, interruptions in the material availability and forming machinery problems do not immediately effect the final assembly. However, due to the parts unusual shape and limber nature, they may be difficult keep in inprocess storage and to reliably feed to the assembly robot without tangling and

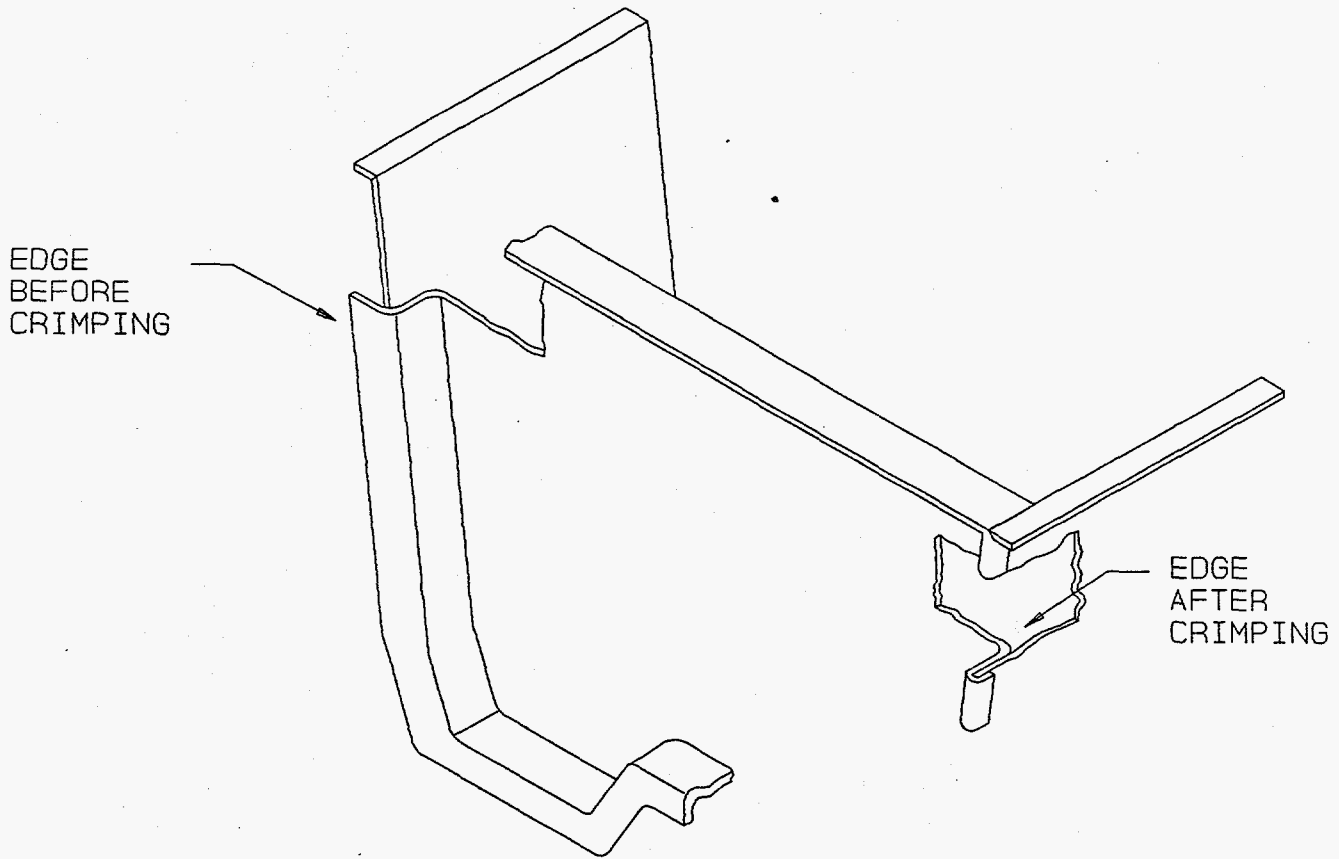

Figure 3.3 Proposed Pan and End Cap Assembly

bending. To avoid the handling problems, the parts could be formed at the final assembly station on an as needed basis.

To follow the later approach may require using pretinned stock to avoid the additional pretinning operation. The additional cost of pretinned stock will be part of the cost trade-offs considered. Figure 3.4 shows some typical details of an electrical interconnect.

Receiver Assembly

There are several issues associated with the final cell assembly mounting in the pan. The assemblies must be accurately positioned. They must remain positioned until the adhesive has set. The electrical interconnects must be attached either after the adhesive has set or while the assemblies are still held in position by the tooling. The over all assembly cycle time must be minimized to control costs.

A rapid setting adhesive may be used for the cell assemblies to allow immediate installation of the interconnects. This may be a heat cure adhesive where a hot air supply is used to activate the adhesive. Alternately, a dual adhesive system could be used. The permanent heat conductive adhesive may be used for most of the joining area. An instant set adhesive over a small portion of the contact area would supply immediate fixturing during assembly until the primary adhesive set.

Another alternative is to have some in process storage of the pans between the cell assembly installation operation and the electrical interconnect operation. This would allow the adhesive to set. There is a potential problem with this approach if, in moving the pans from the cell assembly installation point to an in process storage position, the cell assembly were jarred out of position. A temporary positioning or clamping jig could be employed to avoid this at the expense of additional fixture fabrication and handling.

The selection of an appropriate adhesive would be the preferable solution from an automation perspective and will be pursued in future development work.

Changes to the Module Assembly

The module assembly, as currently conceived, involves assembling the 2x2 lens parquets into a 2x12 configuration. This lens panel is then positioned on the completed receiver assembly and fastened in place with a removeable edge clip.

Lens Partition Clips

The current method of extruding these parts is appropriate for any level of production. Automatic cut off machinery for such extrusions is common in the industry. Automated milling and drilling of the ends is also readily accomodated by modern automated machinery.

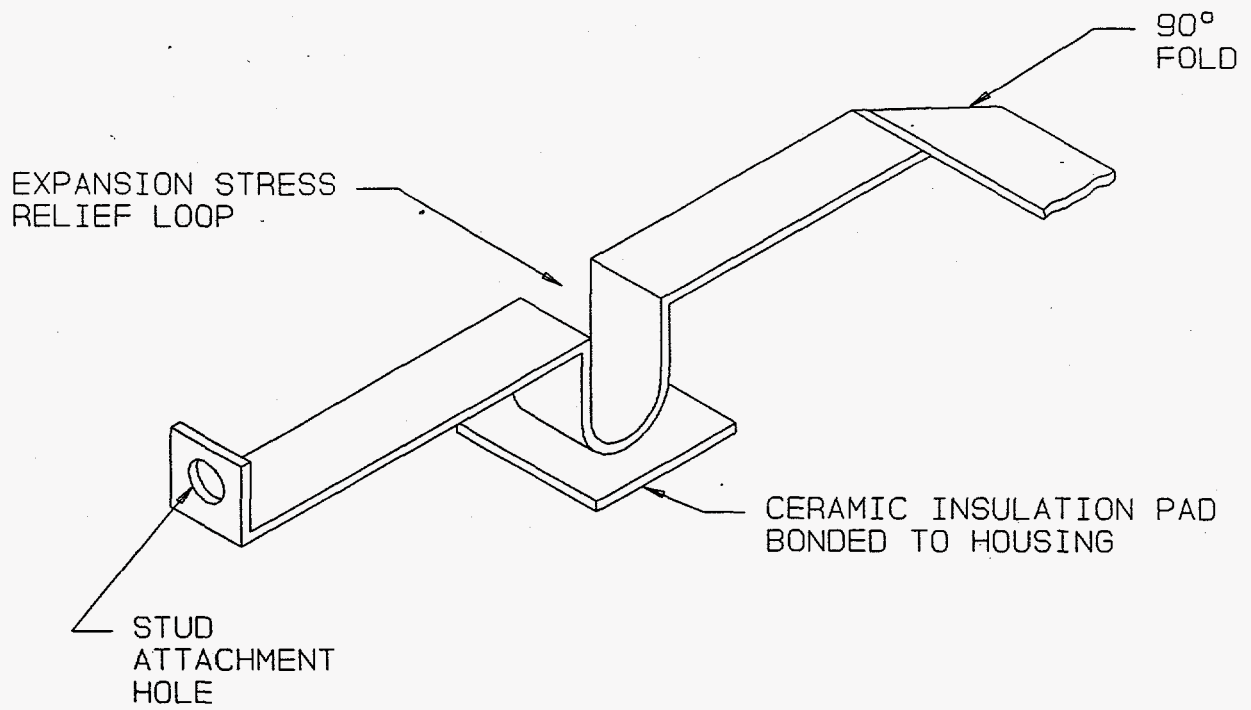

Figure 3.4 Typical Electrical Interconnect Features

The only redesign associated with this part is to modify the grip strength of the clip. The clip must ensure that the lens is gripped tightly enough to prevent leakage and still allow some relative movement to accommodate lens to housing differential expansion and contraction with changing environmental conditions.

Lens Edge Clips

The edge clip is extruded similarly to the partition clip. It is cut with mitered ends to allow good fit up of the adjacent clips on the module.

Lens Assembly

The lenses must first have their edges taped. Automated machinery for this purpose exists in other industries and would require only slight modification for this operation. After taping a custom assembly machine would be required to insert the lens edges into the partition clips and assemble a 2x12 lens panel. Custom equipment will be used to handle this panel also. Due to its bulk and relative fragility, panels will probably be assembled only as needed and be supplied directly to the module assembly station.

Module Assembly

The module assembly operation positions the lens panel on the pan housing. With the pan locked against a known stop, an automated moveable drilling fixture will correct the partition clip locations and screw them in place. Another custom fixture will be used to install the edge clips. Simultaneous installation of opposite edge clips will minimize forces on the pan which could cause distortion.

The last step will be the automatic dispensing of sealant to the appropriate positions in the lens corners by a robot.

Rear Structure

The rear structure design is in a very early stage currently. It would be premature at this time to consider changes for the second design iteration since the first design is not frozen yet.

Drive

No fundamental changes to the drive design are contemplated. Various sources of components require investigation. Selection of specific sources will have some small effects on the detail design. No significant engineering or development effort is required however.

Tracking Control

Designing a dedicated single purpose tracking controller will be necessary when production volume is high enough. The first step in this direction is being taken in a current development contract to SNLA. In this effort SKI is designing and prototyp-

ing a PLC based synthetic tracking controller. The current SNLA contract should permit two generations of this programmable controller to be designed and tested.

After this is accomplished SKI will need to design a dedicated controller based upon the algorithms developed with the PLC system. Experience accumulated at that point will permit specification of a single purpose controller with confidence. Many appliances and industrial machines today have dedicated controllers to control their internal functions and operator interfaces. In cooperation with an experienced manufacturer of such high volume dedicated controllers, SKI will design and cost the dedicated tracking controller. After the projected manufacturing cost of such a unit is known, it will be possible to define what volume of production is required to justify use of the dedicated controller.

Another alternative which will be considered at that time is use of the SolarTrak controller developed by SNLA. As of January 1991, several companies are licensed to manufacture it. None are currently in production or in a position to estimate manufactured costs of the unit. This information should be available by the time the SKI 2nd generation PLC based tracking controller is operational.

Other commercially available tracking controllers will be considered as they become available.

Manufactured Costs

Projections have been made for the manufactured costs of the components for the 20kW array at several different annual volumes. As the market matures and as manufacturing experience is acquired the manufactured costs can be expected to be reduced. This effect is summarized in Table 3.5 . It can be noted that very significant economies of scale are achieved as production rates climb.

The costs reported in the table indicate the direct manufactured cost of each major array sub-system including materials and labor (with burden already added to labor). Also shown is the cost of indirects; overhead, general and administrative expenses (G&A) and profit. Note that the major cost contributors are modules, indirects and drive respectively.

The components of the module cost is presented in Table 3.6. It should be noted that the costs shown indicate the production costs anticipated with implementation of most of the process and design improvements described in this section. Some additional reductions are expected from lens manufacture cost reductions and possibly cell cost improvements also.

The projected cost of indirects is sensitive to several assumptions in the estimating process. For the annual production of 5000 arrays it is likely that a corporation or corporate division dedicated exclusively to this endeavor would be involved. For the fabrication of only 50 arrays, there is probably not enough revenue generated to sup-

Table 3.5

MANUFACTURED COST SUMMARY

Annual Manufacturing Volume MW/yr arrays/Yr	SKI			EPRI ¹	Comments on SKI #'s
	1 MW/yr 50	10 MW/yr 500	100 MW/yr 5000	100 MW/yr 5000	
Modules	36280 ²	27760 ²	19816 ²	18670 ³	SKI current work
Rear Support Structure	2944	1843	1600	1804	SKI current work & [4]
Drive & Motors	10613	4658	3452	4572	[4] [5]
Tracking Control	750	650	550	782	SKI CPVC initiative
Pylon	928	830	696	773	SKI current & (A)
Installation	115	101	89	557	[4]
Foundation	486	450	417	4	[4]
Field Control Wiring	487	400	329	4	[4]
Indirects & profits	10261	5984	4375	4994	SKI current
Sub-total	62864	42676	31323	32151	
\$/KW	3143.22 ⁵	2133.80 ⁵	1566.13 ⁵	1931.93 ⁶	
\$/M ²	359.23	243.86	178.99	289.65	

1. EPRI cost values escalated by 1.31, from 1983 \$ to 1990 \$. [5]
2. Based on 200 module array, 175 m² gross.
3. Based on 80 modules per array, 111 m² gross.
4. These values included in "Installation".
5. Based on 850 W/m²
6. Adjusted to 850 W/m² from 950 W/m²

port major capital investment in highly specialized tooling and automation equipment. This analysis therefore assumes the 50 arrays would be built on a more prototypical basis. The cost breakdowns reflect this. Material overhead and G & A rates are higher than an efficient manufacturing operation would permit. They are, however, typical or even low for a specialty fabricator as would be needed to do this job.

What is not included in the higher volume estimates is a rate of return on the tooling. Tooling investment may be amortized over any number of different time periods or anticipated units of production for whatever anticipated capital recovery factor. This was omitted to allow more direct comparison of these results to work and cost projections done by others. What is included is a lower burden (50%) and material overhead (5%) than used for the lower volume scenario (70% and 25% respectively).

The drive costs presented here are for an elevation over azimuth unit developed for SNLA by Peerless-Winsmith Company for a reflective heliostat application^[4]. The net area and PV array weight are comparable to the heliostat. Production methods and costs have been worked out in detail for the heliostat drive and static load testing and extended field operation testing have been performed at SNLA. Although the cost is the third largest sub-system cost, the estimates are reliable.

The costs for the support structure and installation are based in part upon work done for SNLA on stretched membrane heliostat manufacture^[4]. The single steel tube vertical pylon support and the cast in place pier foundation are almost identical. The motors and shaft position encoders for the drive unit are also very similar. The rear support structure is larger for the array than for the heliostat. However both are simple welded steel truss fabrications. The cost on a dollar/pound basis is assumed to be equivalent.

The tracking control costs are based upon on-going design work being performed for SNLA under the CPVC initiative for concentrating PV modules manufacture. The control costs are based on current quotations for a PLC based controller with complete stand alone synthetic tracking ability.

In Table 3.5 the results of a costing study performed for the Electric Power Research Institute are presented for comparison purposes. These independently determined cost estimates compare closely to the current SKI values. It is also interesting to note that EPRI, after closely investigating numerous alternatives, selected a very similar single pedestal elevation over azimuth support system. The EPRI pylon is also set directly in a cast in place concrete pier. The array support structure is a pair of horizontal torque tubes with intermediate module support rib trusses located at right angles, also similar to the SKI design.

The EPRI cost estimates are scaled to current dollar values and compared to the SKI projections. The net array cost is about equal. The larger size of the SKI array leads to a somewhat lower cost per unit of power output.

A major difference between these studies is the assumed cell efficiency. When the EPRI study was made, it was assumed that the Stanford/EPRI 26% efficient cell would become available at a cost of \$1.00 to \$2.00 each. Current quotations are used by SKI for commercially available cells range from \$0.80 to \$2.00, but with an efficiency of only about 20%. This difference in cell efficiency is what causes the current design's 19% lower cost per Watt inspite of 38% lower cost per unit aperture.

TABLE 3.6
MODULE COST INFORMATION

	Production Rate			Source
	1 MW/yr	10 MW/yr	100 MW/yr	
CELLS				
Cell Cost:	\$2.00	\$1.50	\$0.80	Astro Power
Other Material Cost/Cell:				
Identify: None	N/A	N/A	N/A	
Processing Cost/Cell: Pretinning	\$0.17	\$0.10	\$0.08	SKI
Cell Total:	\$2.17	\$1.60	\$0.88	
Number of Cells/Module:	24	24	24	
Cost/ Module:	\$52.08	\$38.40	\$21.12	
Equivalent Cost/Square Meter:	\$74.40	\$54.86	\$30.17	
<hr/>				
CELL ASSEMBLIES				
Heat Spreader Cost:	\$0.19	\$0.16	\$0.14	Trident
Electrical Isolator Cost:	N/A	N/A	N/A	
Current Collector Cost:	\$0.04	\$0.03	\$0.02	Trident
Prism Cover Cost:	N/A	N/A	N/A	
Solder Cost:	\$0.051	\$0.046	\$0.041	Arconium
Other Material Costs:				
Identify: Coatings	\$0.03	\$0.02	\$0.01	Silvue
Flux	\$0.01	\$0.01	\$0.01	Alpha Metals
Cleaning/etching	\$0.02	\$0.01	\$0.01	Baxter
Processing Cost/Assembly:	\$0.70	\$0.55	\$0.50	SBM3
Cell Assembly Total:	\$1.041	\$0.826	\$0.731	
Number of Assemblies/Module:	24	24	24	
Total Cost/Module:	\$24.98	\$19.82	\$17.54	
Equivalent Cost/Square Meter:	\$35.69	\$28.32	\$25.06	

	Production Rate			
	<u>1 MW/yr</u>	<u>10 MW/yr</u>	<u>100 MW/yr</u>	<u>Source</u>
CELL INTERCONNECTS				
Cell Interconnector Cost:	\$0.07	\$0.06	\$0.03	Trident
Solder Cost:	\$0.012	\$0.012	\$0.010	Arconium
Other Material Costs:				
Identify: Coatings	\$0.001	\$0.0005	\$0.0005	SKI
Etching/cleaning	\$0.01	\$0.005	\$0.005	
Flux	\$0.01	\$0.005	\$0.005	
Processing Costs/Interconnect:	\$0.02	\$0.02	\$0.02	
Number of Interconnects/Module:	24	24	24	
Interconnector Total:	\$2.712	\$2.46	\$1.692	
Other Material Costs/Module				
Identify: Interconnect				
mount/stand-off	\$0.24	\$0.20	\$0.15	
Other Processing Costs/Module:	\$0.24	\$0.12	\$0.12	SKI
Total Cost/Module:	\$3.19	\$2.78	\$1.96	
Equivalent Cost/Square Meter:	\$4.56	\$3.97	\$2.80	

DIODES AND WIRING

Diode Cost:	\$1.00	\$0.75	\$0.50	Micro Semi-cond.
Heat Sink Cost:	\$0.19	\$0.16	\$0.14	Trident
Wire Cost:	\$0.52	\$0.45	\$0.22	Trident
Solder Cost:	\$0.025	\$0.023	\$0.02	Arconium
Processing Costs/Diode:	\$0.03	\$0.02	\$0.01	SKI
Number of Diodes/Module:	3	3	3	
Diode Total:	\$5.29	\$4.21	\$2.67	
Connector Cost:	\$1.50	\$1.00	\$0.75	SKI
Wire Cost:	\$0.035	\$0.03	\$0.015	Trident
Solder Cost	N/A	N/A	N/A	
Number of Connections/Module:	2	2	2	
Wiring Total:	\$3.11	\$2.10	\$1.57	
Total Cost/Module	\$8.40	\$6.31	\$4.24	
Equivalent Cost/Square Meter:	\$12.00	\$9.01	\$6.06	

	<u>1 MW/yr</u>	<u>Production Rate</u> <u>10 MW/yr</u>	<u>100 MW/yr</u>	<u>Source</u>
OPTICS				
Primary Optical Element Cost:	\$11.20	\$6.72	\$1.98	A0/3M/SKI
Identify: (2x6) parquets				
Other Material Costs:				
Identify: Budget	\$0.50	\$0.40	\$0.30	SKI
Processing Cost/Element	\$0.25	\$0.20	\$0.15	SKI
Primary Optical Element Total:	\$11.95	\$7.32	\$2.425	SKI
Primary Elements/Module:	2	2	2	
Cost/Module:	\$23.90	\$14.64	\$4.85	
Secondary Optical Element Cost:	\$0.10	\$0.08	\$0.06	SKI
Identify: Reflective Cone				
Other Material Costs:				
Identify: Stand-off & Adhesive	\$0.05	\$0.04	\$0.03	SKI
Processing Cost/Element:	\$0.20	\$0.10	\$0.05	SKI
Secondary Optical Element Total	\$0.35	\$0.22	\$0.14	
Secondary Elements/Module:	24	24	24	
Cost/Module:	\$8.40	\$5.28	\$3.36	
Total Optical cost/Module:	\$32.30	\$19.92	\$8.21	
Equivalent Cost/Square Meter:	\$46.14	\$28.46	\$11.73	

HOUSING

Basic Pan Material Cost:	\$15.35	\$15.35	\$15.35	Prime Metals
Other Material Costs:				
Identify: Edge Clip	\$2.74	\$2.64	\$2.60	Tower Extr.
Anodization	\$9.00	\$7.00	\$5.00	Anadite
Coatings	\$0.45	\$0.40	\$0.35	Whittaker
End Caps	\$2.36	\$2.00	\$1.60	
Lens Clips	\$1.18	\$1.00	\$0.80	SKI
Processing Cost/Housing:	\$25.00	\$20.00	\$18.00	Roll forming
Housings/Module:				
Cost/Module:	\$56.08	\$48.39	\$43.70	
Equivalent Cost/Square Meter:	\$80.11	\$69.13	\$62.43	

	<u>1 MW/yr</u>	<u>Production Rate</u> <u>10 MW/yr</u>	<u>100 MW/yr</u>	<u>Source</u>
MODULE ASSEMBLY				
Material Costs:				
Identify: Adhesive	\$0.84	\$0.42	\$0.30	Shin-Etsu
Lens sealant	\$1.79	\$1.54	\$1.07	Dow Products
Processing Cost:				
Identify: Place cell assy.	\$0.80	\$0.57	\$0.45	SKI
Solder conductors	\$0.70	\$0.47	\$0.35	SKI
Install diodes	\$0.07	\$0.05	\$0.03	SKI
Install connectors	\$0.02	\$0.01	\$0.01	SKI
Install lens	\$0.15	\$0.12	\$0.10	
Module Assembly Total:	\$4.37	\$3.18	\$2.31	
Cost/Module:	\$4.37	\$3.18	\$2.31	
Equivalent Cost/Square Meter:	\$6.24	\$4.54	\$3.30	

MODULE COST SUMMARY

Module Costs Centers:			
Cells:	\$52.08	\$38.40	\$21.12
Cell Assemblies	\$24.98	\$19.82	\$17.54
Cell Interconnects:	\$3.19	\$2.78	\$1.96
Diodes and Wiring:	\$8.40	\$6.31	\$4.24
Optics:	\$32.30	\$19.92	\$8.21
Housing:	\$56.08	\$48.39	\$43.70
Module Assembly:	\$4.37	\$3.18	\$2.31
Module Total:	\$181.40	\$138.80	\$99.08
Equivalent Cost/Square Meter:	\$259.14	\$198.29	\$141.54

4.0 PRIMARY ISSUES FOR PROPOSED IMPROVEMENTS

Any proposed change to an existing or planned process has issues associated with it which require investigation or verification. When a new material is contemplated, its performance in the specific service must be verified. When a manufacturing process is changed, the tolerances and characteristics of the finished part must be checked against an established standard. The proposed changes described previously in the module and array designs and manufacturing processes must be considered in light of any potential problems they may introduce to the manufacturing process and in service operation of the PV array. These problems and their solutions must be weighed against the benefit sought by implementing the proposed change.

4.1 Manufacturing

Cell

A change currently being investigated for the cell itself is the use of a back contact configuration. The benefits as previously described would be a net increase in cell efficiency. Such a change, however, would necessitate a redesign of the cell assembly at the very least. The heat spreader which currently serves also as a back contact could no longer do so and still be a single piece. The front contact would no longer be required. Since the SOE mounts to the front contact, a new mounting method would be required.

If the cell size is different then the lens dimension and focal distance may also require changing. This in turn would require a different width and depth pan.

Heat Spreader

The heat spreader stock requires pretinning on one side. Currently this is preceded by an etching step. Eliminating this step would be advantageous as discussed in section 3.2. Ensuring an acceptable solder bond without etching requires selection of an appropriate solder and flux combination. It is possible that such a combination will not be found, which also meets the other joint specifications such as strength and reflow temperature.

Electrical Interconnects

The electrical interconnects also require pretinning. The issues related to elimination of etching could potentially effect the electrical interconnect manufacturing processes also.

Another option available is purchasing pretinned coil stock for the interconnects. The presence of the solder may effect the punching and notching operations. The solder may accumulate on the dies and cause problems with the quality of cuts or stripping the material from the punches.

Obtaining pretinned stock with solder which meets the required specifications may be difficult. The solder strength, composition and reflow temperature are critical.

Top Contact

The same issues associated with the electrical interconnects also apply to the top contact. The effect of the solder on pretinned stock on the punching operation could be more critical because of the very fine blanking which is required for the top contact design.

Also the presence of more solder than is necessarily required on the contact fingers may cause problems when soldering to the cell.

Bottom Contact Tab

See issues under electrical interconnects.

SOE

The SOE material is received with a protective premask film laminated to its reflective side. Currently this premask is left in place until after receiver assembly is complete and the lens panel is ready to be installed. In automated assembly, removal of this premask at this stage may be difficult to achieve. To introduce a manual process into the automated assembly operation is not practical. It is probably also not practical to remove the premask while the material is still in its coil stock form although this is the easiest point to do so. The premask is intended to protect the polished surface from handling damage. If the premask were removed prior to blanking and forming it is possible that there would be tooling marks and blemishes made on the reflective surface.

The point in the process where this premask is removed is also influenced by the method used to join the edges of the formed SOE together. A resistance welding process would require removal of the premask from the area to be welded. A mechanical staking process would not require removal. However if the sides of the SOE were staked together with the premask in place, the premask may be even more difficult to remove completely.

This suggests that the premask should probably be removed after blanking but before forming. The forming tooling will be highly polished or made from a relatively soft urethane. The forming machine will be kept very clean to prevent foreign material from being caught between the forming tooling and the reflective surface. Subsequent operations, storage, handling and assembly, will require continued vigilance to prevent damage to the polished surface.

Module Housing Pan

The pan roll forming process uses forming wheels to bend the laminated coil stock as it passes through the machine. The force exerted by these rolls may damage the laminated film. Either contact pressure being too high or the presence of foreign material on the coil stock could cause this to happen. Even if the film were only thinned by the pressure and not cut, the insulating properties may be unacceptably degraded.

Another potential problem with this process is maintenance of adequate tolerances. Changes in the roll set up and changes in the properties of the metal stock can cause changes in the degree of bends in the completed parts.

Pan End Cap

The pan end cap will be formed from prelaminated material. The blanking and forming process could damage the laminated film as a result of local tool pressure and tool wiping action. Even if the film is not cut the insulating properties may be unacceptably degraded where the film is thinned.

Another potential problem is maintenance to tolerances. These can vary with set up changes and variations in the metals mechanical properties.

Cell Assembly Operation

There are several important issues associated with the assembly operation. First is what dimensional accuracy of assembly is required and what factors limit this. The required tolerance is a function of the optics performance and the cell performance combined with the cost of achieving each additional degree of precision. The lens and SOE optics are designed to provide an optimum flux distribution upon the cell's active area. For each unit of cell displacement from the theoretically ideal location there is some loss of cell output. Also, as the axis of the incoming concentrated flux varies from the cells normal axis, some performance is lost. The optics are designed to permit some variation in these factors with minimal effect on cell output. There are however multiple sources of errors which sum to produce a net angular and net translational cell placement error.

Cell assembly tolerances are one source of such errors. A sub-component is robot positioning accuracy. This positioning accuracy is determined by several more factors. The repeatability of the robots actuators and positioners due to mechanical backlash, component deflections under load and control system accuracy effect positioning accuracy. The robot is likely to pick up the cell by its outside edges so the cell dimension and active area placement tolerances are another component.

After the cell and contact components are positioned there is a possibility for accidental displacement of these components before the soldering is completed. This could result from physical jarring of the pieces. It could also result from fluid forces resulting from the melting and vaporizing of the flux in-between the components.

The installation of the SOE has similar constraints as the cell. The optics and cell performance define what positioning tolerance is required. The robot itself has placement tolerances. The components which the SOE fastens to, the foam and the top contact, have dimensional variations which result in variations in the SOE placement.

The bottom contact tab is placed by the same robot but there is less of an issue about its placement tolerance because the parts mating to it, the electrical interconnects, are low precision and quite tolerant of tab positioning.

Receiver Assembly Operation

Cell assembly positioning within the housing pan is a major component of the overall assembly accuracy. As discussed above, the required tolerance for the assembly is defined by the optics and the cell performance. The receiver assembly is largely performed by robot. The same issues of robot repeatability apply as were discussed in the previous section for cell placement. Placing the receiver assembly in the pan is the second step in locating the cell active area with respect to the lens.

The placement of the electrical interconnects does not require a high degree of precision compared to the cell assembly placement.

The attachment of the pan end caps to the housing pan will be accomplished by mechanical crimping. This operation must not induce any distortion into the completed housing. Also the clamping forces for fixturing the parts during crimping must avoid cutting the insulating laminated film. The positioning of the pan end caps will be determined by the assembly fixture and the contour of the parts themselves. The assembly is quite tolerant of the actual end cap positioning because of the way the lens panel is clamped in place. Also the cell assembly positioning within the housing pan is not referenced to the end caps in the assembly process.

Module Assembly

The taping of the lens parquet edges must be accomplished without scatching or marring the lens surfaces. The subsequent assembly of the parquets into a single panel has the same requirements.

The placement of the panel onto the module is the third major component contributing to overall lens to cell placement tolerances. While a robot will perform this operation the actual lens position tolerance is determined by reference lugs molded into the lens parquets and their receiving slots in the module pan edge. (See Figure 4.1) The robot must assure that these lugs are aligned with the slots. Tolerances in notch positioning and lug position are also contributors to overall error.

Lens edge clip installation must be performed without disturbing the lens position or distorting the module housing. The clip must be inserted the correct distance. If the clip is too far onto the edge, freedom of the lens to expand and contract may be im-

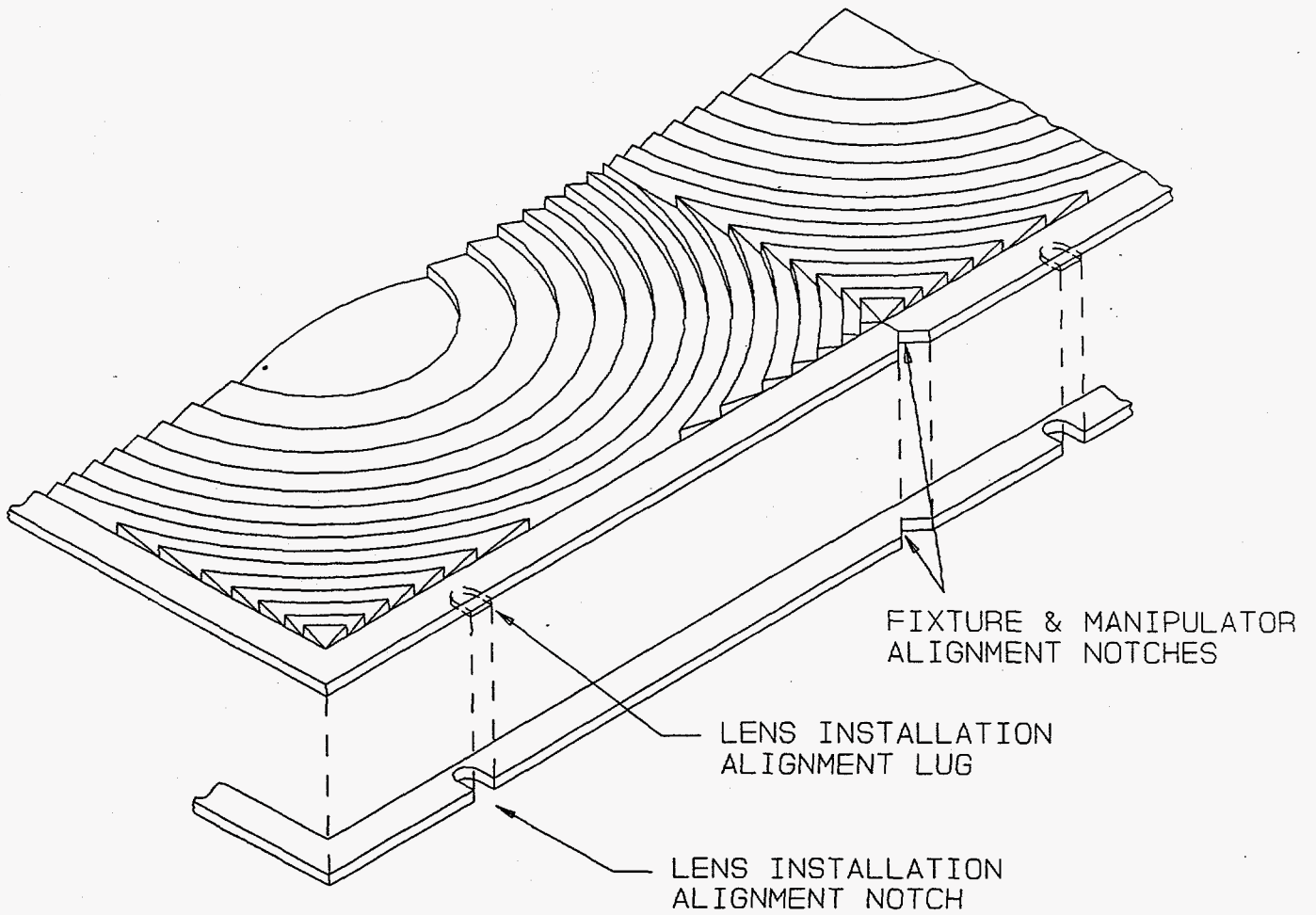

Figure 4.1 Lens and Pan Alignment Details

paired. If the clip is not on far enough sealing integrity may be compromised. Location of the lens partitions is also important to ensure freedom of the lens to expand.

Operational Performance

Issues which must be addressed for the performance of the completed modules are;

- weather seal integrity
- long term electrical insulation integrity
- cell assembly adhesive long-term performance
- solder joint long-term performance
- thermal degradation of cell or cell assembly
- lens distortion due to environmental factors

Failure of a weather seal could permit water and contaminants to enter the module. The presence of pure water alone could result in condensation on the inside of the lens under certain weather conditions. This would degrade module performance by preventing some of the refracted flux from reaching the cell and SOE. Deposition of dust and disheveled solids as the water evaporates on the optical components (cell, SOE and lens) would also degrade performance. Continuous presence of moisture, possibly in combination with elevated internal temperatures, or freeze thaw cycles could adversely affect the adhesives (SOE mounting, cell assembly mounting, insulating film laminate) used in the module. If sufficient volume of water and contaminants entered the module a short circuit could even occur leading to personnel hazards and possible equipment damage.

The long-term integrity of the insulating material in the module is critical. The electrical isolation of the heat spreaders and of the diode mounts prevents internal short circuiting. Such short circuiting would lead to energy loss, potential personnel hazards and potential equipment damage. There are several areas of potential electrical insulation failure. One is the laminated insulating film between the heat spreaders and the housing pan. If this film breaks down with continued exposure to high temperatures and voltage potentials a failure could develop. Another potential failure spot for the laminate is where it is clamped between the housing pan and the pan end cap. If it passes the initial voltage standoff test there is still a possibility the plastic film will creep with time under the pressure of the crimped metal parts and become too thin to provide adequate electrical isolation.

The long-term integrity of the assembly adhesive is a critical issue to the success of this design. The adhesive holding the cell assembly to the housing pan (actually to the insulating film) must withstand continuous high temperature during operation plus the daily cycling of temperature. Some transient and some operational differential expansion between the attached parts exerts shear stresses on the adhesive. Added to this are the thermally induced and gravitational forces transmitted from the interconnects through the cell assembly to the adhesive.

The SOE mounting adhesives see lower loads than the cell mounting adhesive. However the SOE positional stability is very important to the module optical efficiency. Continuous exposure to high operating temperatures must not permit the SOE to shift position.

Another adhesive issue is that of off-gassing. Off-gassing of volatiles from the adhesive must not recondense on the optical surfaces. Such deposits could reduce the optical efficiency by blocking incident solar flux. Continued off-gassing would also be an indication that the adhesive was not stable with extended exposure to elevated temperatures.

Solder joints experience stresses as the attached parts change temperature. Temperature gradients across the solder joint cause differential expansion which results in shear stresses. When the temperature cycles the stresses vary periodically leading to potential fatiguing of the solder joint.

A concentrating PV module must reject heat energy not converted into electrical current. This design uses passive convection and radiation from the back side of the module to reject heat. The heat spreader which the cell is soldered to conducts heat from the cell to the pan housing through the adhesive layer and the insulating film laminate. Each layer has some resistance to heat flow. The ambient air temperature and the convective air currents across the back of the module determine how much heat can be rejected. This in turn determines what the steady state temperature reached by the cell and cell assembly is. If heat rejection is less than anticipated, excessive temperatures may be generated which could degrade cell performance, damage the adhesives or insulators or even the solder joints.

The lens material used in the module is PMMA or acrylic. This material has a relatively high hygroscopic coefficient of expansion. Past experience with large lens panels has indicated some warpage problems, possibly associated with this property. As water is absorbed into the lens panel the material expands. If the panel is prevented from expanding, compressive stresses are created which can lead to out of plane buckling of the panel. There is also a possibility that when a change in ambient humidity occurs, the outer surface of the panel absorbs or releases water to achieve a new equilibrium with the air. The lens material now sees a gradient of water content across its thickness which causes a stress gradient also. This stress gradient will result in a bowing tendency of the flat panel.

Significance of the bowing depends on both the magnitude of bowing and the lens SOE design. The magnitude is determined in part by the lens thickness. A thicker lens will resist higher stresses with less deformation. On the other hand a thicker lens will require more time to attain uniform hygroscopic absorption so transient effects may last longer.

5.0 ANTICIPATED RESOLUTION OF CRITICAL ISSUES

In the previous section critical process and design issues have been identified. This section will describe how these issues will be addressed. Some descriptions are rather general or generic in nature. Other descriptions are quite specific. This variation is a function of the current stage of development of the process being described.

The solutions considered are all selected to optimize automation of the manufacturing operation. The state of development of the final product is such that a concurrent engineering approach with emphasis on integrated product/process design is possible. This is very advantageous for ensuring a cost effective product and manufacturing operation at the conclusion of the current development efforts.

Due to the immature nature of the concentrating PV module technology, its production processes and its market, it is likely that changes and improvements to the process and the design will be regularly implemented as manufacturing and field experience increases and as the market matures. Properly executed automation techniques will permit these necessary changes to be introduced without major production interruptions and retooling expenses. A flexible manufacturing approach is required to achieve this. Additional description of the development of an automatically reconfigurable manufacturing system is provided in section 5.1.

5.1 Manufacturing Approaches

The general system for accommodating process and design changes in the modern manufacturing environment is essential for a company to maintain a competitive position. As previously mentioned, for an immature technology and market, this flexibility is even more important. SKI is working with other experts in this field to ensure such an environment for future PV module and array manufacturing.

The Automatically Reconfigurable Manufacturing System (ARMS) is being designed and constructed at the Automation & Robotics Research Institute (ARRI). The purpose of this Development project is to provide a highly flexible automation "test bed" for industrial use. ARMS will provide the shop floor environment for the development and testing of innovative planning, scheduling, and control techniques and methodologies. Unique robotic applications, flexible material handling system and creative tooling features make this system a highly flexible tool for rapid prototypal purposes. Figure 5.1 shows the conceptual ARMS for PV cell assembly fabrication.

Introduction

In the past, as new projects were undertaken, the work in previous applications was lost due to lack of hardware and software compatibility with the equipment and/or requirements of the new applications. In order to prevent the duplication of the ini-

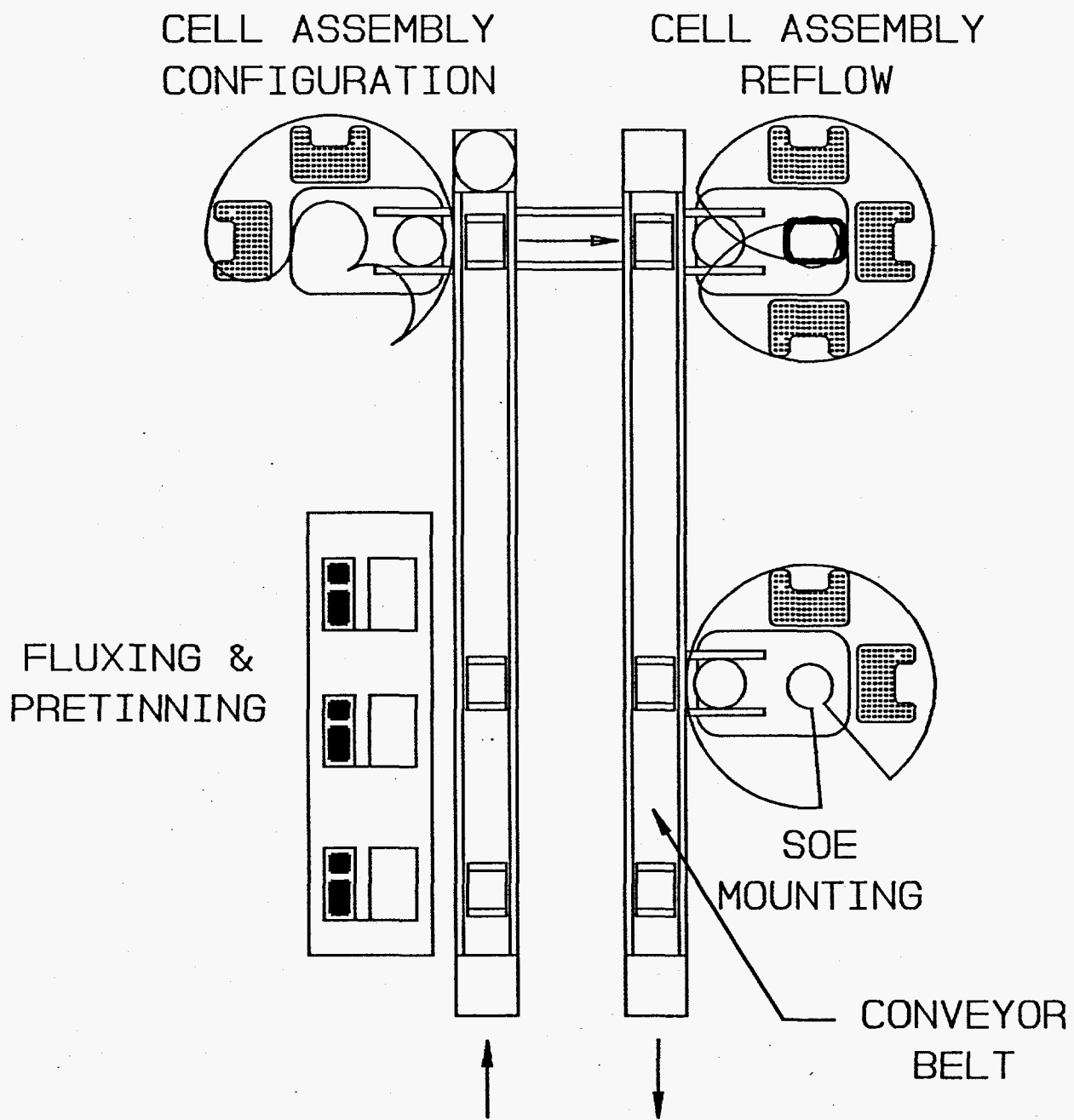

Figure 5.1 Automatically Reconfigurable Manufacturing System for PV Cell Assembly

tial integration effort, a need for a flexible manufacturing system that could be changed rapidly as new applications emerge.

As we progress into the manufacturing of PV Systems, the competitive thrust in manufacturing will shift to time^[6] and flexibility^[7]. Product life cycles are becoming shorter thus the time to bring new products to market must be reduced. Reduced delivery times will also give a competitive edge. Manufacturers add value through the processes they perform on their products. Therefore, having the flexibility to produce a number of products using the same manufacturing processes and the ability to add new ones quickly will also give the company an edge. ARMS provides a "test bed" for the development, implementation, integration and testing of new technologies to attain this flexibility. Figure 5.2 shows a CAD Solid model of a proposed automated cell assembly production line.

The ARMS cell is a flexible manufacturing system aimed at soldering and small mechanical assembly for cell assembly fabrication. Flexible manufacturing systems, such as ARMS, offer cost-effective solutions to the high mix, low volume manufacturing requirements of the concentrating PV module systems. ARMS extends flexible manufacturing by providing the ability to reconfirm the physical make-up of the system through various modules of smaller hardware and software systems. ARMS is capable, in theory, of reconfiguring its physical tooling and software to fulfill the demands of a particular process. The arrangement of these modules is determined by current manufacturing process requirements and can be easily reconverted to support multiple production configurations. All these flexibilities will be valuable during the evolution of SKI's PV products. Figure 5.3 shows a CAD Solid model of a proposed SKI cell assembly workstation.

ARMS consists of several robotic workstations connected by a modular material handling system as shown in Figure 5.4. These workstation form the hardware foundation for the ARMS architecture. This foundation and its control structure will remain constant as new PV modules are introduced. Applications are brought into the generic workstations by process modules. It is these modules that define the individual applications, not the robot itself. The process modules are a unique concept in which interchangeable modular robot tables, instead of dedicated tooling are designed to work with any of the robotic workstations in the cell.

These modules are self supporting, containing all necessary quick change end effectors, parts feeders, and special process equipment, and do not rely on special features of the robot except where necessary. Control of the process module is provided by an "on board" controller. When a module is mounted to a robot table, it becomes part of the larger system under direct control of the robotic workstation. The process modules communicate to the workstation through electrical connections on an interface plate which provides electrical power, air, digital inputs and outputs, and RS232 communications. The process modules are designed to be interchanged between workstation, thus making it 'automatically reconfigurable.'

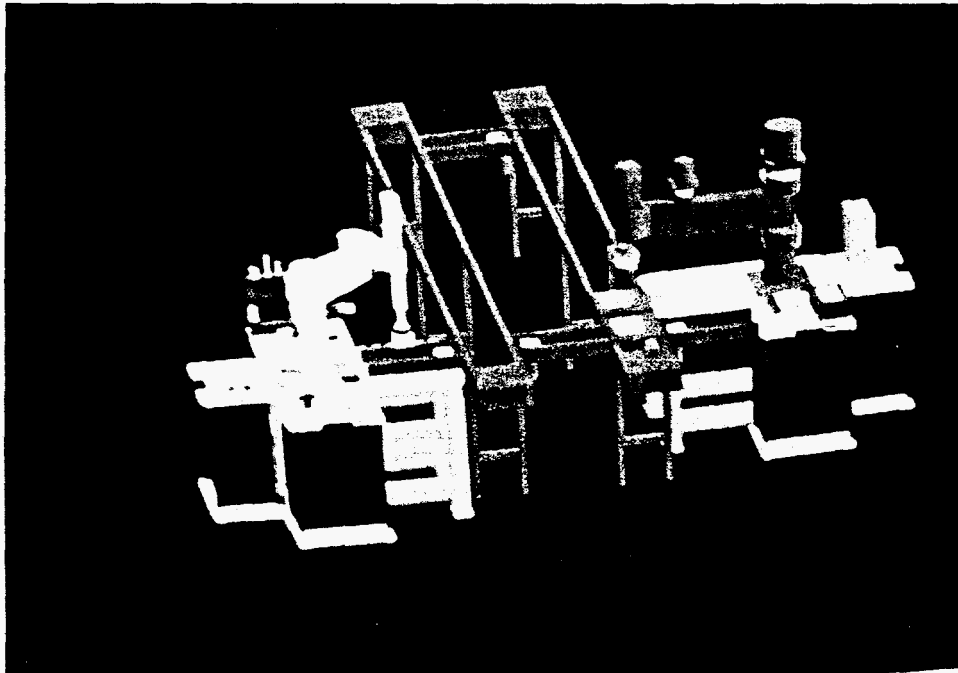

Figure 5.2 CAD Solid Model of Proposed Automated Cell Assembly Production Line.

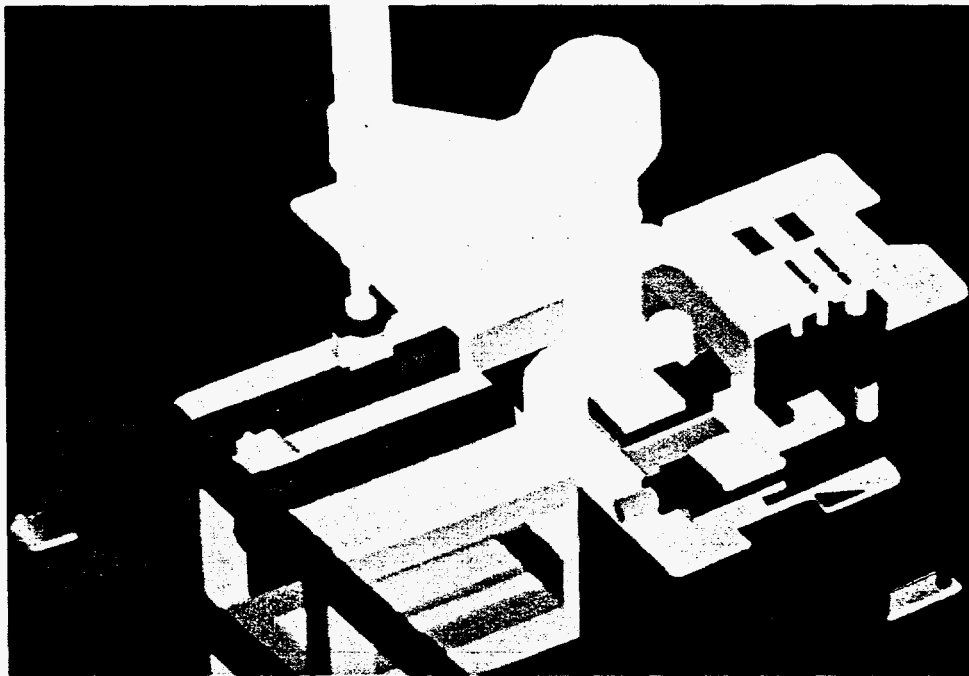

Figure 5.3 CAD Solid Model of Proposed Cell Assembly Workstation.

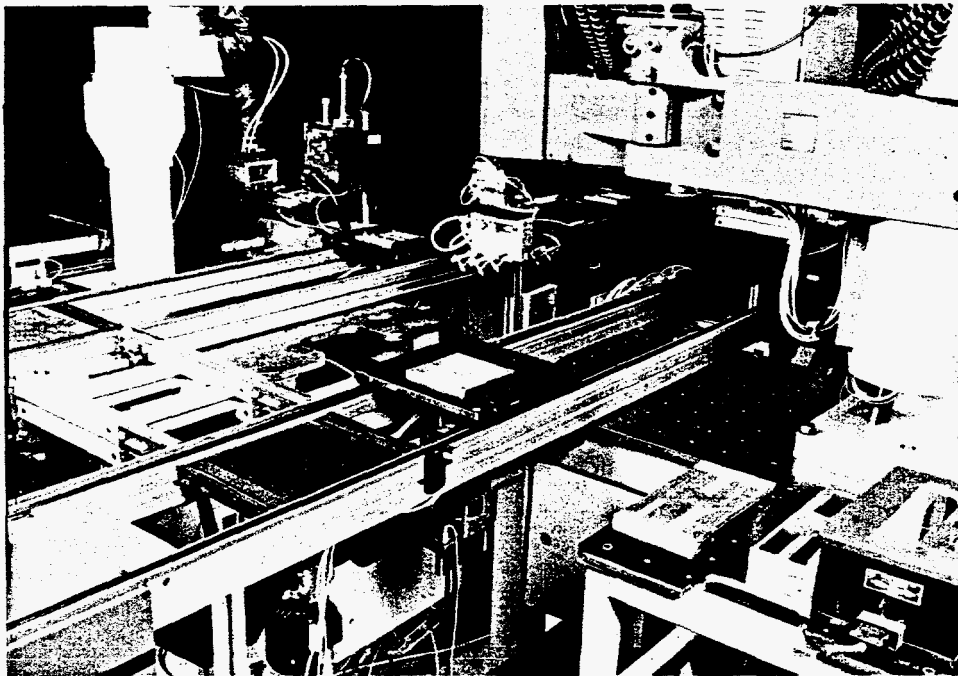

Figure 5.4 Representative Robotic Workstations with Material Handling System.

Cell Control Architecture

The flexibility offered by ARMS is only advantageous if an efficient planning, scheduling, and control concepts, an innovative scheduling architecture for a reconfigurable system based on the scheduling of manufacturing processes rather than products has been developed and is described in references^[8,9].

The scheduling and control architecture implemented in ARMS is largely based on the work done at the National Institute for Standards and Technology (NIST)^{[10][11][12]}. NIST introduced the concept to virtual cell which is a technique using computer control to dynamically group manufacturing processes into cells.^[10] Due to the greater number of components and processes needed to support flexible assembly, ARMS extend the virtual cell concept by allowing not only grouping of processes by software control but also grouping processes physically by allowing processes to be moved into and out of workstations as required by demand. NIST also introduced hierarchical control for flexible manufacturing systems and cell control which is implemented in ARMS^{[11][12]}.

This control model has five levels of hierarchy: facility, shop, cell, workstation, and equipment. In the hierarchical control model, each level in the hierarchy accept orders from the level above, decomposes the orders into its individual tasks, schedules these tasks, dispatches the tasks to the level below, and reports the status back up the hierarchy. This control structure provides the software foundation for the generic workstations. Such a Hierarchical control architecture is shown in Figure 5.5.

Each robotic workstation has different manipulator configurations, robot controllers and overall capabilities. They also have unique programming languages and communication protocols. To provide modularity, the software on each robot will be designed to respond to messages sent from the cell controller in the machine independent manner. The individual tasks are programmed in each robot and invoked by a control message sent to a specific robot by the cell controller. These messages are based on the Manufacturing Message Format Standard (MMFS) and will evolve to the Manufacturing Message Service (MMS) as it develops into the standard messaging language. Using standard messaging formats will allow vendors to provide hardware and software that can be easily integrated into the system of the future.

For example, a single message originated form the cell controller and sent to any one of the robots could look like the following:

```
DRV SCREW(1) 34.5687 745.002 12.000 45 180 0
```

Where DRV tells the robot which program to invoke, SCREW(1) is a variable telling the subroutine DRV what part to pick and the six numbers are the target coordinates instructing the robot where to drive the screw.

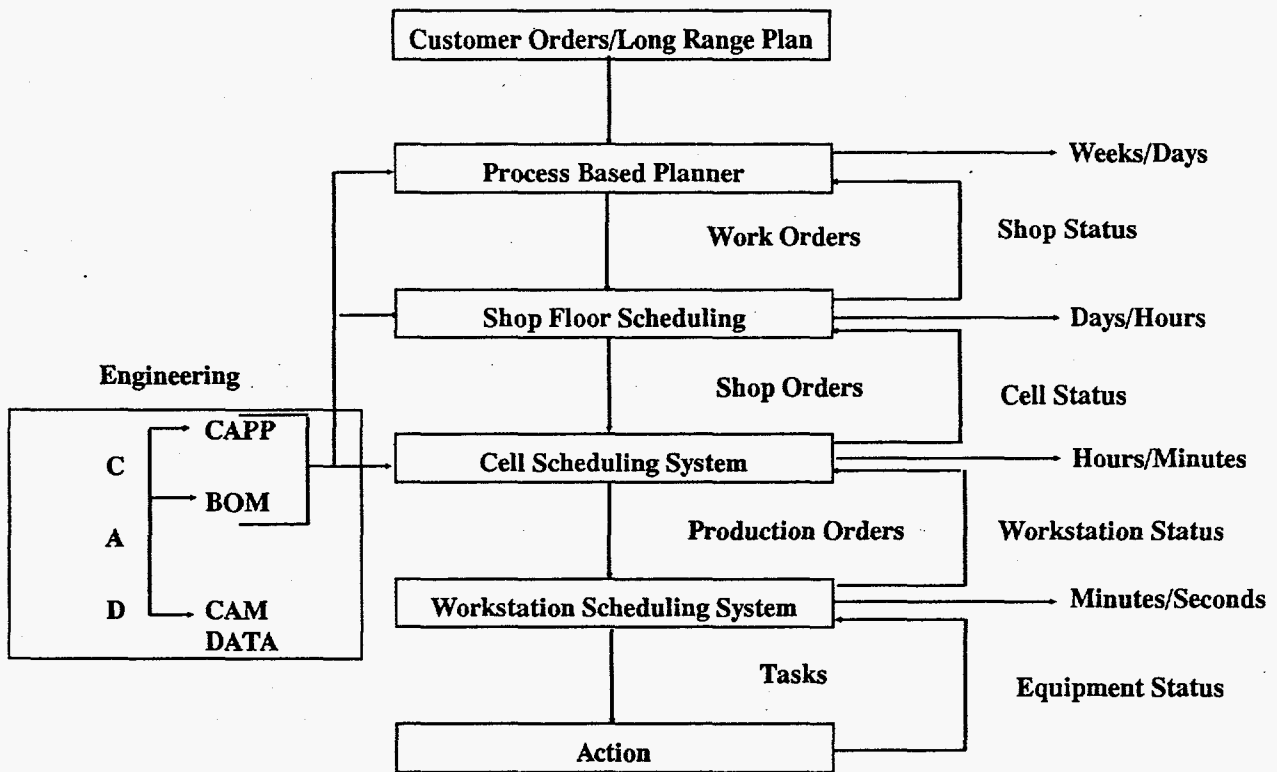

Figure 5.5 Hierarchical Control Architecture for PV Module Manufacturing

The complexity of the program invoked by the message is invisible to the cell controller. It could be a series of subroutines instructing the robot to quick change grippers, initiate processes, report information upline and so on. In most cases the robot programs would be kept to minimum to avoid complex and inflexible robot programming. The cell controller is capable of assembling several sets of control messages, downloading them to the robot controller and thereby "program" the robot off-line.

Currently various hardware is available at ARRI for the major hardware components for the robotic workstations, the AdeptOne, IBM 7547, and PUMA 560 robots, robot tables, process modules, etc. have been acquired and are currently being integrated. The material handling system, a Bosch modular conveyor controlled by a GE Series Six™ PLC, is installed and operational. Processes to be integrated into the ARMS cell will be photovoltaic cell assembly (PVCA) and Module manufacturing. Several processes are being integrated to manufacture photovoltaic cell assemblies^{[13][14][15]}. A linear table, hot bar soldering device, and a vacuum fixture are included in on process module.

The cell control architecture has been outlined and is currently being coded using Savior FLEXIS™. ARMS simulation models have been developed in Silma Cimstation™^[12]. The cell control computer hardware, an IBM PS/2 Model 80™ equipped with ARTIC™ cards to provide multi-tasking communication has been acquired and is being integrated. IBM's Distributed Automation Edition™ (DAE) and Plantworks™ are installed on the cell controller and will be incorporated with the FLEXIS™ model.

Other processes such as screw driving, drilling, routing, soldering and surface grinding are currently in the conceptual stages and plans to develop them in the near future.

Conclusions

ARMS promises to provide a flexible shop floor environment so that prototype manufacturer systems can be developed for PV quickly and cost-effectively, especially for small companies. It should also provide an excellent tool for evaluating the value of flexible manufacturing systems. It should provide a platform for the development and testing of innovative shop floor planning, scheduling, and control algorithms. Finally, it should provide a tool for the development and evaluation of off-line development and programming methods. ARMS and the tools being used to develop and control it address a number of issues that will be of importance in manufacturing of PV systems in the next decade.

5.2 Process Specific Approaches

The following discussions will describe approaches SKI will take toward resolving critical issues for specific manufacturing processes. For the more aggressive or technically risky methods a second fallback approach is also mentioned.

Heat Spreader

The primary issue with heat spreader manufacture was how to eliminate the etching process prior to pretinning. A wave solder technique was identified as the preferred method of applying the pretinning. Selection of an appropriate more aggressive flux will be the first step in eliminating etching. There is a wealth of experience in soldering in the electronics assembly and SMT industry which will be utilized. This activity is very straight forward development work. After consulting with experts in the field, qualified vendors and manufacturers of fluxes will be contacted to obtain additional information and material specifications and samples. The fluxes will be tested on real cell assemblies which will be inspected per our standard X-ray and ultrasound Q.C. procedures. Assemblies which pass the Q.C. will be subjected to temperature cycling to further determine long term effects of the flux change.

Other issues associated with flux selection is the chemical composition of the flux and any potential Environmental, Safety and Health (E,S&H) hazards associated with it. If potential hazards are too great or if a suitably performing flux cannot be found, another precleaning methods will be considered.

The purpose of etching the part is to remove copper oxides and other contaminants which interfere with good wetting and adhesion of the solder. Another method of removing such materials is to abrasively clean the metal. This includes wire brushing, sanding and media blasting. The difficulty with abrasively cleaning copper is that the soft almost gummy character of the metal causes small bits of the abrasive itself to become mechanically imbedded in the metal surface. Abrasive papers and "Scotch-Brite" type media are very likely to leave hard abrasive residues imbedded in the copper. A very clean hard wire brush such as stainless steel may remove the surface coatings without leaving any residue. This approach will be tried, not primarily because of its likelihood of success, but because it is so simple to test and implement if it should happen to work. Media blasting would only work if a media were specified which would not imbed in the copper. A common material used for blasting sensitive surfaces is nut shells. The shell material is relatively soft. The cleaning action comes primarily from the kinetic energy of the particles rather than from any true cutting action. A newer material currently used in only a few applications is solidified CO₂ dry ice pellets. This has the significant advantage of requiring no media clean up or recycling. After use, the CO₂ pellets simply sublimate into the air. There is no solid material used to imbed in and contaminate the copper surface.

Electrical Interconnects and Contacts

It is desirable to eliminate etching with respect to the electrical interconnects. The first approach considered will be to purchase pretinned stock. The issues associated with buying material pretinned are whether suppliers will be willing to supply material in the quantities required and if so at what cost. The volume of material required for the PV manufacturing operation should be sufficient to attract competitive bids on this material. Pretinning on the coil stock is possible by conventional thermal processing or by continuous plating. The plating process should provide bet-

ter control of solder thickness and will be the primary method considered. This may be particularly relevant to the top contact where the small fingers are soldered to the cell. Excess solder at this junction could cause problems with obscuring active cell area or bridging from the top surface to the back.

Appropriate coating of the punching dies should eliminate problems with solder buildup on the tools. Synergistic coatings for cutting tools may be applied by many specialist firms serving the metal processing industry. Use of such coatings should eliminate the necessity of lubricating fluids for the punching and notching operation. Use of fluids is very undesirable because they must be thoroughly removed prior to the solder reflow process.

The top contact contours requires a somewhat challenging blanking operation. The fine size of the contact fingers and the slots separating them require small high precision dies. Close tolerance dies such as these will be more sensitive to solder build up. If too much material builds up the dies will not cut cleanly or strip cleanly. Use of highly polished dies and the aforementioned synergistic tool coatings are expected to solve these problems.

Pretinning interconnects and contacts in the assembly operation is a possibility but not a very desirable one. The only possible advantages it offers is the more efficient use of solder and, in the case of the top contact, elimination of solder build up on the punching tooling. If wire brushing provides sufficient precleaning, at least the initial wet etching and rinsing operations may be eliminated. A post pretinning rinse is still required to remove the flux residue. Also handling the parts for the selective tinning operation would require elaborate machinery and controls.

SOE (Secondary Optical Element)

The principle issue in fabricating the SOE is how and when to remove the premask film. To remove the film automatically would be easiest when the material is still in coil stock form. If this were done, the film would serve almost no purpose. Instead the film will be removed after blanking and forming. This presupposes that the SOE will be fastened by a mechanical staking step instead of welding. This will cost a little more to tool up for but will allow the film to be left in place to protect the reflective surface during fabrication. Operational costs of welding would be greater than staking because the electrode tips require periodic dressing, readjustment and replacement.

Damage to the reflective surface during forming must still be avoided by careful design of that machinery. The forming tooling will be highly polished or made from a relatively soft urethane. The forming machine will be kept very clean to prevent foreign material from being caught between the forming tooling and the reflective surface. Subsequent operations, storage, handling and assembly, will require continued vigilance to prevent damage to the polished surface. The forming tooling will perform one other operation. It will score the premask immediately on either side

of the staked SOE joint. This will permit clean removal of all the premask up to the scored line. Without scoring, the premask may rip at some other location and leave shreds of film inside the SOE which would reduce its performance.

The film will be removed by first picking up its edge with a soft rotating wire brush. Next a vacuum gripping fixture will fit almost entirely inside the SOE. When the vacuum is applied it will draw the film tightly against all four sides of the fixture surface. As the fixture is lifted out of the SOE its slightly flexible sides will help separate the film from the SOE.

Module Housing Pan

The module housing pan will be roll formed. The laminated insulating film on its inside surface will be protected by using relatively large diameter rollers to perform the forming. Corner radii in the pan will not be as tight as in the current press brake formed parts. This will not effect the module performance in any way. It will reduce the contact pressures of the forming rolls on the laminated surfaces during roll forming. It will also benefit the forming of the pan end caps as described below.

Tolerances must be maintained by proper set up of the roll forming machine. Variations due to material mechanical property variations will be minimized by purchase specifications of acceptable ranges of relevant material properties, primarily thickness and yield stress. Beyond this control the module optics design must accommodate a certain variation in lens to cell spacing. Lens and SOE design may be specified to tolerate some variation with minimal effect on module performance. Module width variations will be eliminated, within a defined tolerance range, by the end caps installation and the lens partition installation.

Pan End Caps

Pan end caps will be stamped from laminated stock. To avoid damage to the laminate, long radii on all corners and bends will be used. This reduces tooling forces and reduces the extent of stretch required by the metal and laminate. Use of long radii is consistent with what is required for the roll forming of the housing pan which the end cap must mate. Urethane female tooling will be utilized to further reduce contact pressures between the part and the tooling. Also the low coefficient of friction of urethane reduces the wiping effect of the tooling against the laminate. The Teflon-like laminate will also help reduce friction and related wiping forces.

Part tolerances will be controlled by initial tooling design and by purchased material specifications. An acceptable range of mechanical properties will be specified, principally thickness and yield stress.

Cell Assembly Operations

Maintaining assembly tolerances is a major issue for the cell assembly process. The individual cell assembly components must be assembled within specified tolerances and then kept in that position during soldering. The major issue here is that the top

contact fingers must be positioned on the narrow area of buss bar around the edge of the PV cell. They must not be on the cell active area. They must not stray off the buss bar and remain unconnected or end up connected to the heat spreader. They must rest on the buss bar with sufficient foot print area in contact to assure a sound solder joint and an adequate electrical current path.

Control of top contact finger placement is achieved through two avenues. First the part must be positioned correctly by the assembly robot. This placement is determined by robot repeatability and part dimensional tolerances where the robot grips it. This would be on the outer edge of the top contact. Secondly the finger locations must be accurately located with reference to the gripped edge for the robots placement accuracy to be realized. Because the top contact is to be formed as a continuous coil process and then recoiled for latter assembly, there is a possibility that some of the fingers will be bent in handling. To correct this, just prior to the parts feeder presenting the top contact to the robot, an intermediate reshaping die set will be used. By referencing to the same edge of the part which the robot will grip, the stamping station will re-bend the fingers to ensure correct positioning. This can be readily accomplished since the top contacts are being fed as continuous coil stock.

For the top contact to be placed accurately, the assembly robot must know just where the cell is located. This can be accomplished in two ways. A machine vision system could be placed over the cell assembly station and the image of the cell be acquired to indicate where the top contact should be placed. Alternately, the cell's exterior design dimensions and the heat spreader dimensions could be used to calculate a contact placement position for the robot. As long as the component dimensions are within an acceptable range of tolerances the top contact placement tolerance can be predicted. The vision system would be more tolerant of variations in component dimensions than the hard tooling and calculated position system. It would also be easier to reconfigure for design changes in the top contact, cell or heat spreader. The problem of glare off the cell confusing the imaging system should be surmountable with camera lens filters and minor software modifications.

The use of inductive solder heating during the reflow operation will be used to decrease cycle times and allow firm fixturing of the parts even during the reflow. The grippers and fixtures will be non-inductive materials, such as polymers and machinable ceramics, which will not be heated by the inductive field.

Receiver Assembly

Installation of cell assemblies into the housing pan involves many of the same issues as the cell assembly. As in cell to heat spreader placement, the placement of the cell assembly in the pan is dependent upon robot repeatability, housing pan tolerances and cell assembly tolerances. To assure correct placement by a blind robot, reference dimensions for the critical components must be known within a specific confidence. If this is not the case then the robot cannot be assured of placing the cell assembly precisely. The selected machine vision system will "see" the active cell

surface on the cell assembly and permit closer positioning of the assembly when the outer cell assembly dimensions vary. Some variations in the housing pan will also be accommodated. The vision system guided assembly will permit less expensive "retooling" when new cell designs are introduced with different, or no, top contact requirements.

The mounting of the cell assembly to the pan housing will be by a new adhesive system. The quick cure system must offer the same thermal conductivity, strength and long-term performance as the current silicone adhesive. However a faster acting adhesive is essential to automating this procedure to simplify fixturing, and decrease cycle time. If such an adhesive is not located, the heat spreader design will be altered to permit use of a dual adhesive approach. The "instant" adhesive will provide fixturing while the silicon cures. The "instant" adhesive will be used in an area on the heat spreader away from the cell mounting to minimize its effect on heat dissipation from the cell back.

In anticipation of the lens mounting in the following module assembly operation, a set of notching dies with predetermined center-to-center spacing, is used to mark the pan edge where the lenses should set. The dies must reference off the same points which the vision system used to mount the cell assemblies. This will ensure that the lens foci points are positioned correctly on the cells.

Module Assembly

Module assembly will include interconnect installation and lens clip installation. For interconnect installation, one robot will operate as a pick and place unit. A second robot with a weld or solder head will attach the interconnects to the contacts and diodes.

The lens panel will be placed at the next station. The lens' molded-in lugs on its lower lip must engage the alignment notches punched at the previous operation.

6.0 SUMMARY

In the current work significant progress was made in defining the approach required to achieve low cost high volume manufacturing of point focus concentrating PV modules. Each component and process has been reviewed for how it might be modified for better integration into an automated manufacturing operation. The processes and components with the most significant effect on manufactured cost are discussed in greater detail.

During the conduct of this investigation the importance of two philosophies for the investigators and developers to follow became clear. One is the concept of concurrent engineering. The second is the concept of flexible manufacturing.

Concurrent engineering means that the design of the product and its components is performed hand in hand with development of the manufacturing processes by which they will be made. The components and assemblies must be designed for automation. To ensure this the developers of the manufacturing and automation processes must constantly work with the component designers to achieve the most cost effective final design. An additional advantage of this approach to design is that it not only results in the best final design and process but also accomplish this in less time than a more traditional approach.

The concept of flexible manufacturing is particularly important for this product because of the immature state of its technology and its market. It is inevitable that numerous design and manufacturing process changes will be required. Heavy investment in fixed tooling and inflexible systems would result in expenses which would be avoidable had a flexible system been in place. Installing a flexible system will aid in the prototype stage as well as during production. A flexible system includes heavier use of robots which can be reprogrammed to handle redesigned components. It includes vision systems for insuring part alignment during assembly to avoid the use of hard fixtures which require rebuilding when a part changes. It includes computer integrated manufacturing to provide up to the minute information to workers and management on how the system is operating and what areas require attention.

In addition to the general review one specific critical component was investigated in depth. This critical component whose current projected cost must be reduced is the point focus Fresnel lens. Detailed investigation was performed of alternative materials, processes and manufacturers for this component. This resulted in identification of several high volume experienced injection molding companies with the capabilities to manufacture these parts. Quotations on tooling development and fabrication and on production of lenses were obtained. A cost of \$20 to 25 /m² is attainable. This represents a significant reduction in projected lens manufacturing costs that exceeds the goals set by DOE for this component. These cost are also lower than the DOE goal of \$35/m² for the point focus Fresnel lens.

7.0 REFERENCES

1. Heller, W. H., Peters, J. S., "Development of a Low-Cost Drive Mechanism for Solar-Heliostat", Document Number 90-5753, Peerless-Winsmith, Inc: Springville, NY, 1989
2. Cobb, Jr., S., "Development and Evaluation of an Improved Efficiency Polymeric Web Point-Focus Fresnel Lens", Contract Number DE-AC04-76DP00789, 3M Optics Technology Center, St. Paul, MN, 1987
3. Stillwell, C.B., "Re-Evaluation of an Improved Efficiency Polymeric Web Point-Focus Fresnel Lens", Contract Number DE-AC04-76DP00789, Sandia National Laboratories, Albuquerque, NM, 1988
4. Brown, D., Konnerth III, A., Schertz, P.E., P. and White, P.E., D., "Design and Cost of the First Commercial Stretched-Membrane Heliostat", Sandia Contract #42-9691: Albuquerque, NM, 1991
5. Black & Veatch, Engineers-Architects, "Conceptual Design for a High-Concentration (500X) Photovoltaic Array", Research Project Number 1415-7, Black & Veatch, Engineers-Architects, Kansas City, MO, 1984
6. Ebner, M.L. and Vollman, T.E., ed. M.D. Oliff, "Manufacturing for the 1990's", Intelligent Manufacturing, The Benjamin/Cummings Publishing Company, Inc.: Melo Park, 1988
7. Davis, J., and Oliff, M.D., "Requirements for the Integration of Manufacturing Planning Islands Using Knowledge Based Technology", Expert System and Intelligent Manufacturing, Elsevier Science Publishing Co., Inc.: New York, NY, 1988
8. Smith, Craig B. and Kline, Eric H., "Modular Robot System for electronics Assembly", Proceedings Controls West Conference, 1985
9. Liles, Donald H. and Huff, Brain L., "A Computer Based Scheduling Architecture Suitable for Driving a Reconfigurable Manufacturing System", Proceedings 12th Conference on Computers and Industrial Engineering, 1990
10. McLean, C.R., Bloom, H.M., Hopp, T.M., "The Virtual Manufacturing Cell", National Bureau of Standards, Washington DC, 1982
11. McLean, C.R., "A Cell Control Architecture for Flexible Manufacturing", Proceedings of the 1987 Advanced Manufacturing System Conference, 1987
12. McLean, C.R., "An Architecture for Intelligent Manufacturing Control", Proceedings of Summer 1985 ASME Conference, 1985

13. Criswell, T.C. and Collins, J.H. et al, "Application of Simulation Modeling to the Automated Manufacture of Photovoltaic Cell Assembly", Proceedings of The Fourth National Conference on Microcomputer Applications in Energy, 1990
14. Fitzgerald, M., Vanecek, D., and Jackson, M. C., "Automated Manufacturing of Integrated Photovoltaic Cell-Mounted Assemblies for Linear Fresnel Lens Concentrator Collectors", Proceedings for Solar 90, 1990
15. Simpson, J.A., Hocken, R.J., Albus, J.S., "The Automated Manufacturing Research Facility of the National Bureau of Standards", Journal of Manufacturing Systems, Vol. 1-1, 1982

APPENDIX

SUBJECT: SPECIFICATION FOR HIGH CONCENTRATION SILICON CONCENTRATOR SOLAR CELL: P/N 60-7046

1.0 MANUFACTURER: APPLIED SOLAR ENERGY CORPORATION

1.1 SCOPE

This specification defines design, construction and testing of silicon concentrator solar cell. This concentrator solar cell is also referred to as the cell.

2.0 APPLICABLE DOCUMENTS AND DRAWINGS

2.1 ASEC P/N 60-7046

2.2 ASEC Drawing A-204323 High Concentration Si Concentrator Cell

3.0 CELL DESIGN

3.1 The cell is a N +/P/P + configuration.

3.2 Starting Materials:

3.2.1 Single crystal float zone (FZ) silicon.

3.2.2 P-type silicon, boron doped.

3.2.3 .17-.23 ohm-cm resistivity.

3.2.4 100 orientation.

3.2.5 .008 ± .002 inch thick.

3.3 The N + junction is formed by phosphorus diffusion.

3.4 The P + back surface layer is formed by alloying of evaporated layer of aluminum.

3.5 The gridline pattern and dimensions are determined by computer aided design to optimize cell performance for high concentration sunlight.

3.6 The front contact (N-contact) and gridline metals are conventional evaporated Ti-Pd-Ag, chosen because of the known overall high performance and high reliability. The silver thickness for front contact and gridlines are 7 to 10 um.

3.7 The back contact (P-contact) of the solar cell is conventional evaporated Al-Ti-Pd-Ag. The silver thickness for back contact is 3 to 5 um.

3.8 The active area is coated with antireflective coating of titanium dioxide and aluminum oxide optimized for AM1 sunlight spectrum.

3.9 The contact metals and AR coating will be sintered to ensure good adhesion.

4.0 MECHANICAL SPECIFICATIONS

- 4.1 Drawing: ASEC A-204323
- 4.2 Size: .542 x .542 inch overall, .406 x .406 active area.
- 4.3 Thickness: .008 ± .002 inch.
- 4.4 Any evidence of peeling or lifting of contact metals due to poor contact adhesion is considered a reject.
- 4.5 A maximum contact voids of 2% is allowed for both contacts.
- 4.6 Minor gridline discontinuities are not considered as a reject as long as the electrical requirements are met.
- 4.7 Maximum allowable edge chips and nicks are .020 inch in depth and .100 inch in length.
- 4.8 Maximum allowable corner chips or nicks are .150 inch on the hypotenuse.
- 4.9 Voids in AR coatings are not rejects as long as electrical requirements are met.

5.0 ELECTRICAL SPECIFICATION

- 5.1 The minimum cell efficiency is 16% at 385 suns concentration and 28°C ± 2°C.
- 5.2 The minimum average cell efficiency for each shipping lot is 17.0% at 385 suns concentration and 28°C ± 2°C.
- 5.3 The solar cells are tested at 385 times solar constant (AM1) and 28 ± 2°C. The test voltage is 600 ± 2mV. The solar cells are grouped into the following groupings:

Group No.	Min. Current At 600 mV (AMP)	Min. Efficiency (%)
1	10.9	16.0
2	11.2	16.4
3	11.5	16.8
4	11.8	17.3
5	12.1	17.7
6	12.4	18.2
7	12.7	18.6
8	13.0	19.0

- 5.4 The minimum output current for the shipping lot is 10.9 Amperes at 600mV. The average shipping lot is 11.6 Amperes at 600 mV.

6.0 QUALITY ASSURANCE PROVISIONS

6.1 Responsibility of Inspection

ASEC is responsible for the performance of the mechanical inspection and electrical testing as specified herein in paragraphs 4.0, 5.3 and 5.4.

6.2 Mechanical Inspection

Each cell is inspected to meet the mechanical specifications per paragraph 4.0.

6.3 Electrical Performance

The electrical performance of each cell is tested to assure compliance with cell electrical specifications per paragraph 5.3 and 5.4.

7.0 SHIPPING

- 7.1 Solar cell will be packed in containers which are adequate to protect the cells from mechanical damage. Each container will contain solar cells of the same electrical groupings. Cells shall be packaged in a hermetically sealed container with desiccant and a relative humidity indicator for shipment.

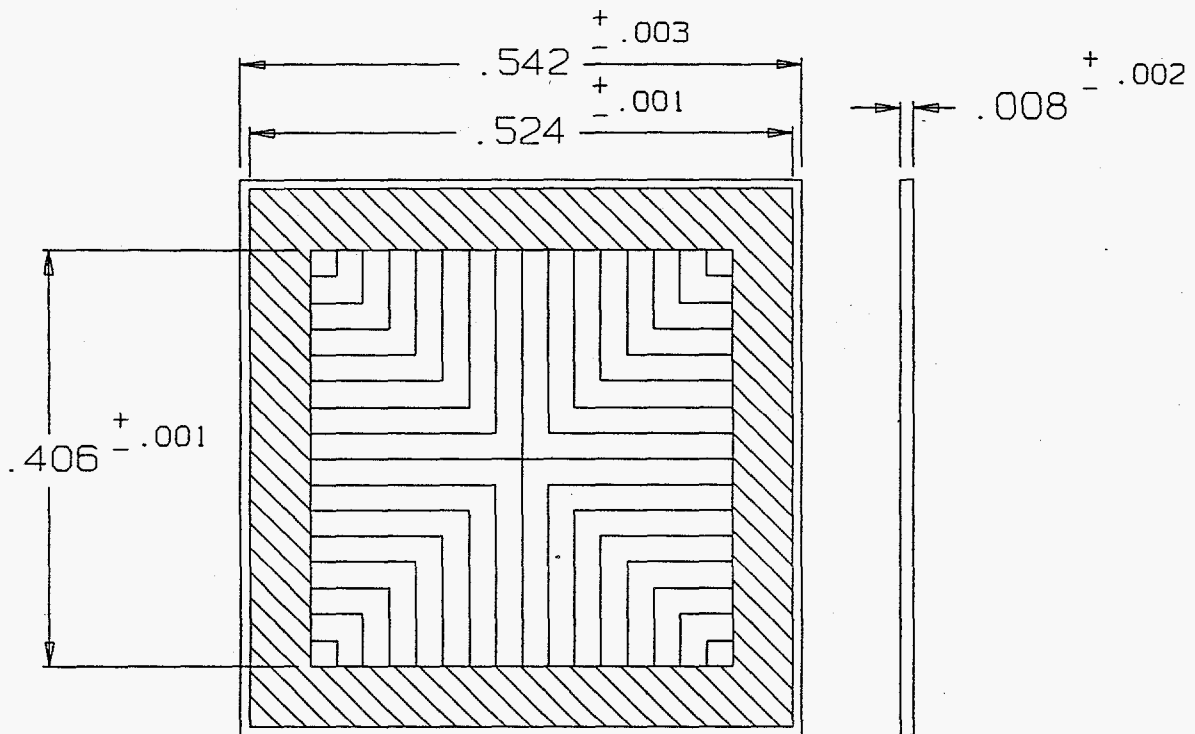

NOTE:

- 1.0 The solar cell is designed for high concentration sunlight application.
- 2.0 The solar cell is N + PP + silicon solar cell made from high quality, float zone (FZ) P-type silicon with substrate resistivity of 0.17 – 0.23 Ohm.
- 3.0 The N-contact (front) is vacuum deposited titanium-palladium-silver. The P-contact (back) is vacuum deposited of aluminum-titanium-palladium-silver. The silver thickness on the gridline and front contact is 7 to 10 um. The silver thickness for the P-contact is 3 to 5um.
- 4.0 The active area is coated with antireflective coating of titanium, dioxide, and aluminum oxide optimized for AM1 solar spectrum.

Document Control Page	1. SERI Report No. SERI/TP-214-4477	2. NTIS Accession No. DE91015028	3. Recipient's Accession No.
4. Title and Subtitle Low-Cost Manufacturing of the Point-Focus Concentrating Module and Its Key Component, the Fresnel Lens			5. Publication Date November 1991
			6.
7. Author(s) S. T. Saifee, A. Konnerth III			8. Performing Organization Rept. No.
9. Performing Organization Name and Address Solar Kinetics Inc. 10635 King William Dr. Dallas, Texas			10. Project/Task/Work Unit No. PV150101
			11. Contract (C) or Grant (G) No. (C) XC-1-10057-15 (G)
12. Sponsoring Organization Name and Address National Renewable Energy Laboratory 1617 Cole Blvd. Golden, Colorado 80401-3393			13. Type of Report & Period Covered Technical Report
			14.
15. Supplementary Notes NREL Technical Monitor: R. Mitchell, (303) 231-1379			
16. Abstract (Limit: 200 words) Solar Kinetics, Inc. (SKI) has been developing point-focus concentrating PV modules since 1986. SKI is currently in position to manufacture between 200 and 600 kilowatts annually of the current design by a combination of manual and semi-automated methods. This report reviews the current status of module manufacture and specifies the required approach to achieve a high-volume manufacturing capability and low cost. The approach taken will include process development concurrent with module design for automated manufacturing. The current effort reviews the major manufacturing costs and identifies components and processes whose improvements would produce the greatest effect on manufacturability and cost reduction. The Fresnel lens is one such key component. Investigating specific alternative manufacturing methods and sources has substantially reduced the lens costs and has exceeded the DOE cost-reduction goals.			
17. Document Analysis			
a. Descriptors Point focus concentrating photovoltaic modules ; manufacturing ; Fresnel lens ; components ; photovoltaics ; solar cells			
b. Identifiers/Open-Ended Terms			
c. UC Categories 275			
18. Availability Statement National Technical Information Service U.S. Department of Commerce 5285 Port Royal Road Springfield, VA 22161			19. No. of Pages 100
			20. Price A05