

107
7/16/91 JS (2)



ORNL/TM-11907

**OAK RIDGE
NATIONAL
LABORATORY**



**Worldwide Advanced Nuclear
Power Reactors with Passive and
Inherent Safety: What, Why,
How, and Who**

Charles W. Forsberg
William J. Reich

MANAGED BY
MARTIN MARIETTA ENERGY SYSTEMS, INC.
FOR THE UNITED STATES
DEPARTMENT OF ENERGY

This report has been reproduced directly from the best available copy.

Available to DOE and DOE contractors from the Office of Scientific and Technical Information, P.O. Box 62, Oak Ridge, TN 37831; prices available from (615) 576-8401, FTS 626-8401.

Available to the public from the National Technical Information Service, U.S. Department of Commerce, 5285 Port Royal Rd., Springfield, VA 22161.

This report was prepared as an account of work sponsored by an agency of the United States Government. Neither the United States Government nor any agency thereof, nor any of their employees, makes any warranty, express or implied, or assumes any legal liability or responsibility for the accuracy, completeness, or usefulness of any information, apparatus, product, or process disclosed, or represents that its use would not infringe privately owned rights. Reference herein to any specific commercial product, process, or service by trade name, trademark, manufacturer, or otherwise, does not necessarily constitute or imply its endorsement, recommendation, or favoring by the United States Government or any agency thereof. The views and opinions of authors expressed herein do not necessarily state or reflect those of the United States Government or any agency thereof.

**WORLDWIDE ADVANCED NUCLEAR POWER REACTORS
WITH PASSIVE AND INHERENT SAFETY:**

WHAT, WHY, HOW, AND WHO

Charles W. Forsberg
William J. Reich

September 1991

Prepared for
U.S. Department of Energy

Prepared by the
OAK RIDGE NATIONAL LABORATORY
Oak Ridge, Tennessee 37831-2008
managed by
MARTIN MARIETTA ENERGY SYSTEMS, INC.
FOR THE
U.S. DEPARTMENT OF ENERGY
under contract DE-AC05-84OR21400

MASTER

TABLE OF CONTENTS

| | |
|---|-----|
| LIST OF FIGURES | vii |
| LIST OF TABLES | ix |
| EXECUTIVE SUMMARY | xi |
| 1. INTRODUCTION | 1 |
| 1.1 REPORT OBJECTIVES | 1 |
| 1.2 CAVEATS | 2 |
| 1.3 REPORT ORGANIZATION | 3 |
| 2. WHAT IS THE NEW DIRECTION IN NUCLEAR POWER? | 4 |
| 2.1 HISTORY | 4 |
| 2.2 DEFINITIONS | 4 |
| 2.2.1 Evolutionary Plant Reactors | 4 |
| 2.2.2 Evolutionary Technology Reactors | 5 |
| 2.2.3 PRIME Reactors | 5 |
| 3. WHY NEW DIRECTIONS IN NUCLEAR POWER? | 6 |
| 3.1 SAFETY IS THE ISSUE | 6 |
| 3.1.1 Political Deadlock | 6 |
| 3.1.2 Competition | 6 |
| 3.1.3 Economics | 6 |
| 3.1.4 Greenhouse Effect | 7 |
| 3.1.5 Regulatory | 7 |
| 3.2 TECHNICAL REVOLUTION | 7 |
| 4. HOW TO ACCOMPLISH GOALS? | 8 |
| 4.1 REACTOR OPTIONS | 8 |
| 4.1.1 Process Inherent Ultimate Safety Reactor | 8 |
| 4.1.1.1 Approach | 8 |
| 4.1.1.2 Technical Description | 8 |
| 4.1.2 Advanced CANDU Reactor | 10 |
| 4.1.2.1 Approach | 10 |
| 4.1.2.2 Technical Description | 10 |
| 4.1.3 Modular High-Temperature Gas-Cooled Reactor | 10 |
| 4.1.3.1 Approach | 10 |
| 4.1.3.2 Technical Description | 12 |
| 4.1.4 Analysis | 12 |
| 4.2 SUPERCONTAINMENTS | 15 |
| 4.2.1 Approach | 15 |
| 4.2.2 Technical Description | 15 |
| 4.2.3 Assessment | 17 |

| | | |
|----------|---|----|
| 5. | WHO IS WORKING ON ADVANCED OPTIONS? | 18 |
| 5.1 | CANADA | 18 |
| 5.1.1 | Technical Programs | 18 |
| 5.1.2 | Assessment | 18 |
| 5.2 | FRANCE | 18 |
| 5.2.1 | Technical Programs | 18 |
| 5.2.1.1 | Water-Cooled Reactors | 18 |
| 5.2.1.2 | Modular High-Temperature Gas-Cooled Reactor ... | 19 |
| 5.2.1.3 | Supercontainments | 19 |
| 5.2.2 | Assessment | 19 |
| 5.3 | GERMANY | 20 |
| 5.3.1 | Technical Programs | 20 |
| 5.3.1.1 | High-Temperature Gas-Cooled Reactor | 20 |
| 5.3.1.2 | Supercontainments | 20 |
| 5.3.2 | Assessment | 20 |
| 5.4 | ITALY | 21 |
| 5.4.1 | Technical Programs | 21 |
| 5.4.1.1 | Light-Water Reactors | 21 |
| 5.4.1.2 | Supercontainments | 21 |
| 5.4.1.3 | Modular High-Temperature Gas-Cooled Reactor ... | 21 |
| 5.4.1.4 | Other | 22 |
| 5.4.2 | Assessment | 22 |
| 5.5 | JAPAN | 22 |
| 5.5.1 | Technical Programs | 22 |
| 5.5.1.1 | Light-Water Reactors | 22 |
| 5.5.1.2 | High-Temperature Gas-Cooled Reactor | 22 |
| 5.5.2 | Assessment | 23 |
| 5.6 | NETHERLANDS | 23 |
| 5.6.1 | Technical Programs | 23 |
| 5.6.2 | Assessment | 23 |
| 5.7 | SOUTH KOREA | 23 |
| 5.7.1 | Technical Programs | 23 |
| 5.7.2 | Assessment | 23 |
| 5.8 | SWEDEN | 24 |
| 5.8.1 | Technical Programs | 24 |
| 5.8.2 | Assessment | 24 |
| 5.9 | SWITZERLAND | 25 |
| 5.9.1 | Technical Programs | 25 |
| 5.9.1.1 | Light-Water Reactors | 25 |
| 5.9.1.2 | Modular High-Temperature Gas-Cooled Reactor ... | 25 |
| 5.9.2 | Assessment | 25 |
| 5.10 | UNION OF SOVIET SOCIALIST REPUBLICS | 26 |
| 5.10.1 | High-Temperature Gas-Cooled Reactors | 26 |
| 5.10.2 | Assessment | 26 |
| 5.11 | UNITED STATES | 26 |
| 5.11.1 | Technical Programs | 26 |
| 5.11.1.1 | Light-Water Reactors | 26 |

| | | |
|----------|---|----|
| 5.11.1.2 | Modular High-Temperature Gas-Cooled Reactor . . . | 27 |
| 5.11.1.3 | Supercontainments | 27 |
| 5.11.1.4 | Other | 27 |
| 5.11.2 | Assessment | 28 |
| 6. | CONCLUSIONS | 29 |
| 7. | REFERENCES | 30 |
| | APPENDIX A: DIRECTIONS IN REACTOR DEVELOPMENT | 33 |
| A.1 | INTRODUCTION | 33 |
| A.2 | EVOLUTIONARY PLANT REACTORS | 33 |
| A.3 | EVOLUTIONARY TECHNOLOGY REACTORS | 33 |
| A.4 | BREEDER REACTORS | 33 |
| A.5 | PRIME REACTORS | 37 |
| A.6 | REFERENCES | 39 |
| | APPENDIX B: PRIME SAFETY | 41 |
| B.1 | REFERENCES | 45 |
| | APPENDIX C: TECHNICAL DESCRIPTIONS OF REACTOR AND CONTAINMENT CONCEPTS | 46 |
| C.1 | INTRODUCTION | 46 |
| C.2 | PIUS REACTOR | 46 |
| C.3 | MODULAR HIGH-TEMPERATURE GAS-COOLED REACTOR | 49 |
| C.4 | SUPERCONTAINMENTS | 52 |
| C.4.1 | Containment Structure | 52 |
| C.4.2 | Reduced-Accident Source Term | 56 |
| C.5 | REFERENCES | 62 |
| | APPENDIX D: EVOLUTIONARY TECHNOLOGY REACTORS | 64 |
| D.1 | INTRODUCTION | 64 |
| D.1.1 | GENERAL | 64 |
| D.1.2 | TECHNICAL DESCRIPTION | 64 |
| D.2 | ARGENTINA | 66 |
| D.2.1 | GENERAL CHARACTERISTICS | 66 |
| D.2.2 | TECHNICAL CHARACTERISTICS | 66 |
| D.3 | JAPAN | 68 |
| D.3.1 | HITACHI SMALL BWR | 68 |
| D.3.1.1 | General Characteristics | 68 |
| D.3.1.2 | Technical Characteristics | 68 |
| D.3.2 | MITSUBISHI SIMPLIFIED PWR | 72 |
| D.3.2.1 | General Characteristics | 72 |

| | | |
|---------|---------------------------------|----|
| D.3.2.2 | Technical Characteristics | 72 |
| D.3.3 | SYSTEM-INTEGRATED PWR | 76 |
| D.3.3.1 | General Characteristics | 76 |
| D.3.3.2 | Technical Characteristics | 76 |
| D.3.4 | TOSHIBA 900 | 80 |
| D.3.4.1 | General Characteristics | 80 |
| D.3.4.2 | Technical Characteristics | 80 |
| D.4 | UNITED STATES | 83 |
| D.4.1 | ADVANCED PASSIVE-600 | 83 |
| D.4.1.1 | General Characteristics | 83 |
| D.4.1.2 | Technical Characteristics | 83 |
| D.4.2 | SIMPLIFIED BWR | 87 |
| D.4.2.1 | General Characteristics | 87 |
| D.4.2.2 | Technical Characteristics | 87 |
| D.5 | UNITED KINGDOM | 90 |
| D.5.1 | SAFE INTEGRAL REACTOR | 90 |
| D.5.1.1 | General Characteristics | 90 |
| D.5.1.2 | Technical Characteristics | 90 |
| D.6 | REFERENCES | 95 |

LIST OF FIGURES

| | | |
|---------|--|----|
| Fig. 1 | PIUS Pressurized Water Reactor | 9 |
| Fig. 2 | Advanced CANDU reactor concept | 11 |
| Fig. 3 | MHTGR-GT module | 13 |
| Fig. 4 | Modular high-temperature gas-cooled reactor | 14 |
| Fig. 5 | Example German supercontainment building | 16 |
| Fig. C1 | Operating principles of PIUS | 48 |
| Fig. C2 | Proposed PIUS design by ABB Atom | 50 |
| Fig. C3 | 350 MW(t) modular HTGR unit | 53 |
| Fig. C4 | MHTGR-GT power cycle process | 54 |
| Fig. C5 | Example of German advanced containment structure | 57 |
| Fig. C6 | Cumulative release fractions of radionuclides to containment by Chemical group and concrete type after core-melt accident | 58 |
| Fig. C7 | Core melt source reduction system (COMSORS) | 60 |
| Fig. D1 | Schematic of the Modular Low-Power CAREM Reactor | 67 |
| Fig. D2 | Schematic of the Hitachi Small Boiling-Water Reactor | 69 |
| Fig. D3 | Mitsubishi Simplified Pressurized-Water Reactor | 73 |
| Fig. D4 | System-integrated pressurized-water reactor | 77 |
| Fig. D5 | Toshiba TOSBWR-900P Reactor | 81 |
| Fig. D6 | Westinghouse Advanced Passive-600 Reactor | 84 |
| Fig. D7 | General Electric Simplified Boiling-Water Reactor | 88 |
| Fig. D8 | Safe integral reactor containment boundary and pressure suppression system | 91 |
| Fig. D9 | Primary circuit flow diagram for safe integral reactor | 92 |

LIST OF TABLES

| | | |
|-----------|--|----|
| Table A.1 | Advanced reactors | 34 |
| Table B.1 | International Atomic Energy Agency draft descriptions of terms | 42 |
| Table C.1 | Some key design data for the PIUS (Secure-P) Reactor | 51 |
| Table C.2 | United States MHTGR major plant parameters for the 450 MW(t) design | 55 |
| Table D.1 | Key design specifications of the Japanese HSBWR-600 | 70 |
| Table D.2 | Principal design parameters of the Mitsubishi Simplified PWR | 74 |
| Table D.3 | Principal design parameters of the System-Integrated Pressurized-Water Reactor | 78 |
| Table D.4 | Main design parameter of the Toshiba TOSBWR-900P Reactor | 82 |
| Table D.5 | Major design specifications of the Westinghouse Advanced Passive-600 Reactor | 85 |
| Table D.6 | Major design parameters of the Safe Integral Reactor | 93 |

EXECUTIVE SUMMARY

The political controversy over nuclear power, the accidents at Three Mile Island (TMI) and Chernobyl, international competition, concerns about the carbon dioxide greenhouse effect and technical breakthroughs have resulted in a segment of the nuclear industry examining power reactor concepts with PRIME safety characteristics. PRIME is an acronym for Passive safety, Resilience, Inherent safety, Malevolence resistance, and Extended time after initiation of an accident for external help. The basic ideal of PRIME is to develop power reactors in which operator error (e.g., TMI, Chernobyl), internal sabotage, or external assault do not cause a significant release of radioactivity to the environment. The commercial interest in such reactors is based on three considerations: (1) breaking the political deadlock over nuclear power and, thus, allowing construction of new reactors; (2) competitive advantage—recognizing that if such a reactor can be built economically, no utility would consider buying a conventional nuclear power plant; and (3) possibly lowering costs via radical simplification in power plant design. There are significant disagreements within the international nuclear power community about the technical, economic, and political feasibility of this new approach to nuclear power.

Several PRIME reactor concepts are being considered. In each case, an existing, proven power reactor technology is combined with radical innovations in selected plant components and in the safety philosophy. The Process Inherent Ultimate Safety (PIUS) reactor is a modified pressurized-water reactor, the Modular High Temperature Gas-Cooled Reactor (MHTGR) is a modified gas-cooled reactor, and the Advanced CANDU Project is a modified heavy-water reactor. In addition to the reactor concepts, there is parallel work on super containments. The objective is the development of a passive "box" that can contain radioactivity in the event of any type of accident.

Different reactor vendors and different countries are examining various options. PIUS and other light-water-cooled reactor options with PRIME characteristics are being developed or evaluated in Sweden, Italy, Japan, and the United States. MHTGR concepts are being developed or evaluated in France, the United States, Germany, and the Soviet Union. Canada is examining PRIME heavy-water reactors. Supercontainments are being examined in Germany and Italy.

This report briefly examines: (1) why a segment of the nuclear power community is taking this new direction, (2) how it differs from earlier directions, and (3) what technical options are being considered. A more detailed description of which countries and reactor vendors have undertaken activities follows. The appendices (70% of this document) provide additional information in specific areas.

1. INTRODUCTION

1.1 REPORT OBJECTIVES

The objective of this report is to provide a description of *one* new direction of nuclear power development worldwide. This is the development of nuclear power reactors with fundamentally different safety characteristics. The impetuses for these new developments are (1) the nuclear power plant accidents at the Three Mile Island (TMI) nuclear power station and at the Chernobyl nuclear power station, (2) the subsequent public debate about the acceptability of nuclear power, and (3) the economics of nuclear power.

The key characteristic of the TMI and Chernobyl accidents was that the operators shut down functional safety systems for what seemed to be good reasons at the time. If those safety systems had remained operational, the accidents would not have occurred. These were accidents of commission—deliberate actions by operators—not equipment failures or failure to follow instructions. The solution proposed to eliminate these and other safety issues is the use of passive and inherent safety. It is a radical change in technology. Whether it will be a technical, economical, and institutional solution to solve the problems associated with nuclear power is unknown.

The concepts of passive and inherent safety can best be understood by the use of these terms in the context of fire protection. A concrete warehouse full of pottery is inherently safe against fire. In other words, a fire cannot occur. Inherent safety implies that there is no need for safety systems. An example of passive safety is water sprinklers. Active safety, then, would be the fire department. Current power reactors use active safety systems. Nuclear reactors cannot be made inherently safe because they contain hazardous radioactive materials, but reactors can be made inherently safe against specific types of accidents. Most types of power reactors are inherently safe against the kind of reactor accident that occurred at Chernobyl [Martinez, 1990]. While active safety, the current technology, works most of the time, plant operators (like fire departments) can make errors. To prevent a TMI or Chernobyl accident, the safety systems cannot have off switches or depend on power supplies which have off switches.

The new direction of nuclear power development is important for several reasons. It signals a worldwide shift in nuclear power priorities of government and private interests from breeder reactors with associated reprocessing to new reactor concepts with once-through fuel cycles. Secondly, there are potentially major economic benefits to the companies or countries if they are successful in developing the technology. Nuclear power is potentially low cost, but its cost depends strongly on public acceptance. If safety issues, as perceived by the public, can be addressed by technology, countries with such technology will have access to lower energy costs. Simultaneously, there is a large export market for such technologies. Finally, environmental concerns—particularly the greenhouse effect—are becoming important political issues. The acceptability of nuclear power strongly impacts what can be done to address greenhouse problems.

1.2 CAVEATS

First, the international nuclear power community is divided on what its future direction should be. The new direction for nuclear power discussed herein is controversial within the technical community, the reactor vendors, national governments, and international organizations [Weaver, 1991a]. There are numerous examples of contradictory statements and perspectives from different organizations and from the same organizations. To help provide a more coherent perspective, this report includes assessment sections. *These assessments are the authors' individual evaluations of what is happening based on multiple informal discussions and other sources of information.* Evaluations do not necessarily represent organizational viewpoints.

Second, the structure of the world's nuclear enterprise is in a state of transition [NEA, 1991]. A decade ago, nuclear programs were organized along national lines. While there were multinational programs, in most cases, there was a dominant partner. Today, the concept of a "national" nuclear reactor program is changing. Several examples will provide an understanding of these changes.

1. The United States historically had four domestic reactor vendors. Today, Combustion Engineering is a wholly owned subsidiary of the Swedish-Swiss company Asea Brown Boveri (ABB). Babcock and Wilcox is partly owned by the French reactor vendor Framatome. General Electric is in partnership with the Japanese to develop and build the Advanced Boiling-Water Reactor. The first two reactors of this kind are being built in Japan.
2. In Europe, the Siemens subsidiary Kraftwerk Union of Germany is in partnership with Framatome of France for the next generation of the light-water reactor.
3. The Process Inherent Ultimate Safety (PIUS) reactor is being developed by ABB in Sweden. Its U.S. subsidiary, ABB Combustion, is interacting with the U.S. Nuclear Regulatory Commission (NRC) for a preliminary safety review. ABB is further developing PIUS in Italy with the Italian reactor vendor.

This report describes programs by nation, but it is important to understand these international linkages and that most reactor programs cannot be considered in the narrow context of a single country.

Third, many reactor vendors and countries are developing multiple reactor options—hedging bets. Passive and inherent safety is only one direction for nuclear power.

Last, several other recent reports complement this report. A recent report describes the current status of Western European nuclear power generation and technology [Turinsky, 1991]. A parallel report describes activities in Japan [Hansen, 1990]. A series of reports address the status of specific nuclear technologies in foreign countries [NEA, 1991; Lanning, 1991].

1.3 REPORT ORGANIZATION

The report is organized into six chapters and a set of appendixes. To provide an understandable perspective, the chapters provide a description and overview, with details placed in the appendixes. The report is organized around four basic questions:

- (1) What is the new direction of nuclear power?
- (2) Why are some organizations considering new directions in nuclear power?
- (3) How are the goals to be accomplished?
- (4) Who is working on advanced options?

2. WHAT IS THE NEW DIRECTION IN NUCLEAR POWER?

2.1 HISTORY

The long-term goal for development of nuclear power is straight forward: develop an economic, safe, environmentally acceptable, unlimited supply of energy for society. Superimposed on the long-term goal have been various short-term objectives. The history of nuclear power in the United States and most other countries of the world can be divided into the three following time periods.

From the 1940s through about 1960, the development of nuclear power was accelerated by the cold war and concerns about national prestige. As one historian [Arthur, 1990] described the early development of the light-water reactor in the United States: "The role of the U.S. Navy in early reactor construction contracts, efforts by the National Security Council to get a reactor—any reactor—working on land in the wake of the 1957 Sputnik launch . . . all acted to favor the early development of light-water reactors . . ." While the details differ from country to country, national prestige and national security issues were the early driving forces for nuclear power.

As nuclear power developed, concerns about the availability of nuclear fuel, particularly uranium, became the dominant nuclear power issue in government policy circles. This led to development of breeder reactors and more fuel-efficient converter reactors throughout the world. The breeder reactor is a reactor that makes more fuel than it consumes. The Liquid Metal Fast Breeder Reactor (LMFBR) received the most attention. By 1980, the discovery of very large reserves of uranium in many parts of the world made it clear that uranium shortages would not occur for many decades, if ever.

In 1979, there was a partial reactor core meltdown at the Three Mile Island nuclear power station in the United States. In 1986, there was a catastrophic reactor accident at Chernobyl in the Union of Soviet Socialist Republics. With these two events, the third era of nuclear power development was initiated—a very high concern for nuclear reactor safety and corresponding concerns about the public acceptance of nuclear power as an energy source.

2.2 DEFINITIONS

During each era of nuclear power development, reactors were characterized by their ability to address the key concern of that time period. Today, safety is the unifying issue in nuclear power; thus, reactors can be categorized by their safety characteristics. The categorization scheme used herein is based on the functional characteristics of the reactor safety systems.

2.2.1 Evolutionary Plant Reactors

Evolutionary plant reactors have designs similar to existing reactor designs, but they include the usual evolutionary improvements that occur over time with any technology. In terms of reactor safety, these reactors have complex safety systems with diesel engines, pumps, valves, and various control systems. Safety, in the event of an accident, depends on proper startup

and continued operations of complex safety systems to prevent reactor core damage. All power reactors under construction today are in this category.

2.2.2 Evolutionary Technology Reactors

Evolutionary technology reactors are proposed future reactors that use the technology of current reactors, but they include significant changes in plant design and layout. Safety, in the event of an accident, depends on passive safety systems and safety systems started up by simple actions such as opening valves, but which are passive in operation (i.e., no moving equipment, such as pumps, motors, or control systems are needed for continued safety system operation). These reactor designs would not require a demonstration plant before placement of reactor orders. Appendix D further describes the Evolutionary Technology Reactors.

2.2.3 PRIME Reactors

PRIME reactors—the subject of this report—are proposed future reactors with radical changes in safety systems. The safety systems require neither active initiation nor active operation of equipment to operate. Different designers have used various terms to describe the safety characteristics of such reactors. One generic term used to describe these characteristics is PRIME, which is an acronym for Passive safety, Resilient safety, Inherent safety, Malevolence resistance, and Extended time for external aid after an accident. Appendix B further describes these characteristics.

A central philosophy of such designs is that the reactor safety system must be designed to work in spite of operator actions. In both the Chernobyl and TMI accidents, the operators shut down functional safety systems for what were thought to be good reasons at the time. PRIME reactors, by definition, have no off switches for safety systems. Unlike the previously mentioned designs, PRIME reactors may, but not necessarily, require a demonstration plant before a utility would be willing to order multiple reactor units. Appendix A provides additional details on each class of reactor described herein.

3. WHY NEW DIRECTIONS IN NUCLEAR POWER?

3.1 SAFETY IS THE ISSUE

There are multiple incentives to develop PRIME reactors. As a consequence, there are very different motivations by the various organizations developing these reactors. This also applies to the motivations of national governments.

3.1.1 Political Deadlock

In a number of countries, there are strong economic incentives for nuclear power, but the political controversy over nuclear power has prevented the construction of new power plants. In these countries, PRIME reactors are considered a mechanism to break the political deadlock. In some countries (i.e., Italy), national law prevents construction of new nuclear power plants unless there are major improvements in safety. In other countries (i.e., Sweden), radical changes in reactor safety technology may provide a face-saving mechanism for political leaders and political parties to change laws prohibiting new nuclear power plants. New technology provides a rationale to reevaluate earlier stated positions.

3.1.2 Competition

Nuclear power is controversial. If a reactor vendor can show that his reactor has (1) clear safety advantages, (2) equivalent economics, and (3) equivalent performance over alternative reactor options, the market will strongly favor him in those countries where nuclear power plants are being ordered. Both financial and political forces would make other reactor options difficult to sell.

3.1.3 Economics

PRIME reactors may (if successful) improve reactor economics by two mechanisms.

1. Current cost estimates are that 30 to 60% of the cost of nuclear power is related to health, safety, and environment. This implies that if major improvements in economics are to be obtained, new approaches to safety are required. The cost of active safety systems is a major factor in the cost of nuclear power [Cook, 1985; UDI, 1988; Golay, 1988; Carnesale, 1981].

2. The cost of money is a significant contributor to the capital cost of nuclear power, and the cost of money depends on investment risk. The higher the risk, the higher the cost of money. For nuclear power plants, there is the risk of an accident at the particular plant or at a neighboring plant. After the TMI and Chernobyl accidents, owners of similar plants suffered significant financial penalties from plant retrofits and permanent shutdown of some reactors of somewhat similar designs. This phenomena has also been seen in the aircraft and chemical industries after major accidents.

3.1.4 Greenhouse Effect

Recent environmental concerns—particularly the carbon dioxide greenhouse effect—may imply expansion of nuclear power by an order of magnitude [Forsberg, 1990] and large-scale use in underdeveloped countries. This has major implications for long-term safety requirements and approaches to safety.

1. The public acceptance of any technology partly depends on the absolute number of accidents, not the accident rate. This was first emphasized in 1963 in the aircraft industry by the Swedish engineer Bo K. O. Lundberg [Weinberg, 1989; Lundberg, 1963]. Lundberg recognized that if the aircraft accident rate was constant and there was continued growth of the industry, the public acceptance of the industry and of flying would be a major problem because of the publicity of each accident. The experiences of the aviation industry on the institutional necessity for reducing accident rates is probably applicable to the nuclear industry.

2. If nuclear power is to be used on a large scale in underdeveloped countries, there will be increased concerns about the low skill levels, political instabilities, and limited resources applied to safety [Kessler, 1990; Goldman, 1990; Hibbs, 1990]. These factors may increase accident probabilities if passive and inherent safety technologies are not used.

3.1.5 Regulatory

The safety of the current nuclear power plants depends critically on reactor design, construction, and operations. Operator errors on a single shift (e.g., TMI and Chernobyl) can result in major accidents. This sensitivity of safety to operations imposes a very heavy burden on governments and their regulatory authorities. For government policymakers, the political risks of nuclear power would be substantially reduced if power plant safety was less dependent on operator performance.

3.2 TECHNICAL REVOLUTION

It is important to stress that with these concepts, the emphasis by the proponents of these technologies is on a radical step change in nuclear technology in terms of safety to break the old mindsets. As Dr. Paul Gray, former president and current chairman of the governing board of the Massachusetts Institute of Technology, stated [Cash, 1991] when discussing one of these concepts, [what we are] "talking about are not incremental improvements, but discontinuous changes from what we see today."

4. HOW TO ACCOMPLISH GOALS?

This chapter provides a brief semitechnical description of the technologies that have created this new option for nuclear power. This includes both reactor options and supercontainment options.

4.1 REACTOR OPTIONS

Examples of the three major PRIME reactor options are described in the following. In each case, the example is the leading concept for that particular reactor type. The safety issues for the designers of any reactor are to remove reactor decay heat (failure at TMI) and control reactor power levels (failure at Chernobyl). In a nuclear power reactor, radioactive decay heat *continues* after reactor shutdown at an initial level of ~1% of full power. The heat source *cannot* be shut off. If the reactor is not cooled after reactor shutdown, the reactor core will melt. Power control is also required. The descriptions emphasize passive decay heat removal, which is thought to be the primary failure mechanisms leading to reactor accidents.

4.1.1 Process Inherent Ultimate Safety Reactor

4.1.1.1 Approach

The PIUS reactor [Hannerz et al., 1990; ABB Nuclear Reactors, Inc., 1989; ABB-Atom, 1989] is a conventional pressurized-water reactor (PWR) with conventional power generation equipment and a radically innovative safety system. PWRs are the dominant type of nuclear power reactor in the world today. ABB is a supplier of both PWRs and boiling-water reactors. The design philosophy of PIUS is to minimize technical change to the power plant except for safety systems, the area in which radical improvements in performance are desired. PIUS is under development by the ABB research and development team located at the corporate research center in Vasterås, Sweden, and by several other research and development facilities worldwide. The nominal power output is 600 MW(e).

4.1.1.2 Technical Description

The reactor safety systems (Fig. 1) have two major components: (1) a very large prestress concrete reactor vessel, and (2) a large pool of cool borated water in the pressure vessel. All critical safety equipment and the nuclear reactor are inside the concrete pressure vessel. The concrete reactor vessel, similar in principle to a gas-cooled concrete reactor pressure vessel, protects the reactor core and safety systems against external and internal assault. Its wall thickness is ~7 m.

The reactor vessel internals are divided into two compartments. One compartment contains the cool borated water, and the other contains the reactor core with the primary reactor coolant. Emergency cooling is provided by the large volume of cool borated water in the pressure vessel. The inventory is sufficient to cool the reactor core by water boiloff for a week versus most reactors today in which the in-vessel water supply is sufficient to cool the reactor for only a few hours. The two water compartments are directly connected through hot/cold water interfaces near the top and bottom of the reactor vessel. During normal

ORNL DWG 90-325R

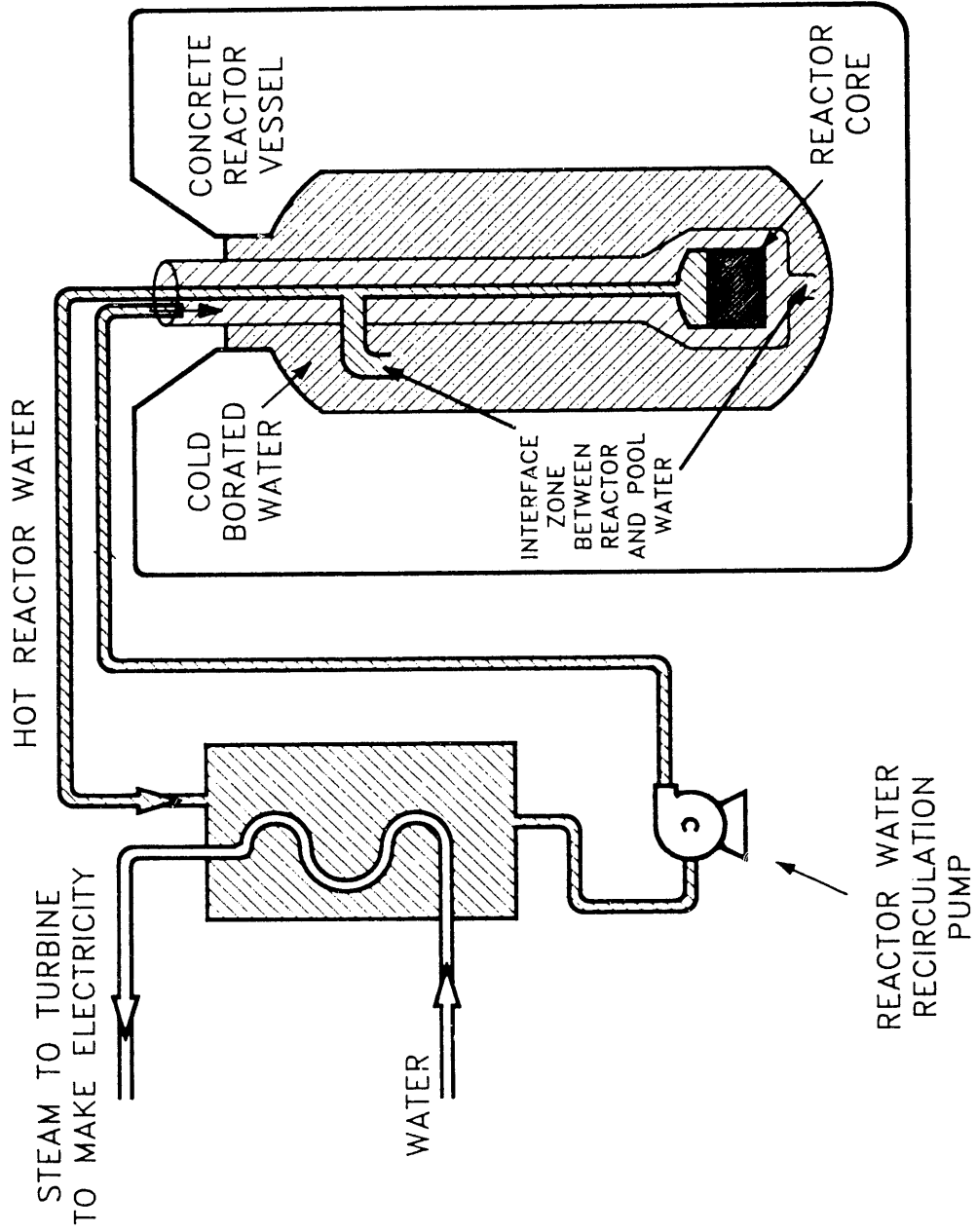

Fig. 1. PIUS Pressurized-Water Reactor.

operations, a hydraulic balance achieved through appropriate flow of primary coolant is maintained by the main reactor circulation pumps, resulting in no transfer of water between the two compartments. In the event of a pump failure, coolant line break, or reactor overpower incident, the hydraulic balance is upset and cold borated water flows into the reactor core, shutting down the reactor. The water then circulates between the two zones. Heat is ultimately removed from the reactor vessel by boiloff of in-vessel borated water (7-d water supply). In effect, the reactor will only operate if the recirculation pumps function at the correct speed and the primary reactor water boron control is correct. Off operation shuts down the reactor. A more detailed description is given in Appendix C.2.

4.1.2 Advanced CANDU Reactor

4.1.2.1 Approach

Research and development groups at Chalk River Laboratory in Canada have begun to investigate a CANDU reactor with passive safety systems—the Advanced CANDU. The plant is similar in most respects to earlier heavy-water reactor designs except for details of plant layout and radical innovations in a few selected components, such as the pressure tubes. Nominal size would be ~900 MW(e). This organization is the traditional supplier of Canadian heavy-water power reactors.

4.1.2.2 Technical Description

In a traditional heavy-water reactor, small fuel bundles are placed inside high-pressure tubes. The insulated high-pressure tubes are in a cold tank of unpressurized heavy water called a "calandria." The cold, heavy water in the calandria is a "nuclear moderator," a "catalyst" that alters the energy of neutrons that control the nuclear chain reaction. When the reactor operates, cold water enters one side of each pressure tube and is heated by the fuel. The hot water then flows to a steam generator to dump heat and produce steam, and the cold reactor water is pumped back to the pressure tubes. In current reactors, if there is a break in the reactor coolant lines, emergency cooling water is pumped in to keep the fuel cool and below its melting point.

With the Advanced CANDU (Fig. 2), if the fuel overheats, as it would in an accident, the pressure tube also overheats. The pressure tube has the unique characteristic, that if a certain temperature is exceeded, the tube becomes highly conductive to heat rather than acting as an insulator. Excess heat that could melt the fuel is instead dumped to the calandria. The pool temperature is kept cool by heat pipes or other mechanisms that dump the heat to the environment (air or water).

4.1.3 Modular High-Temperature Gas-Cooled Reactor

4.1.3.1 Approach

In the United States and a number of other countries, the Modular High-Temperature Gas-Cooled Reactor (MHTGR) is being developed as a power reactor. The nominal power output is in the range of 100 to 173 MW(e) per reactor. HRGRs have been built in the past.

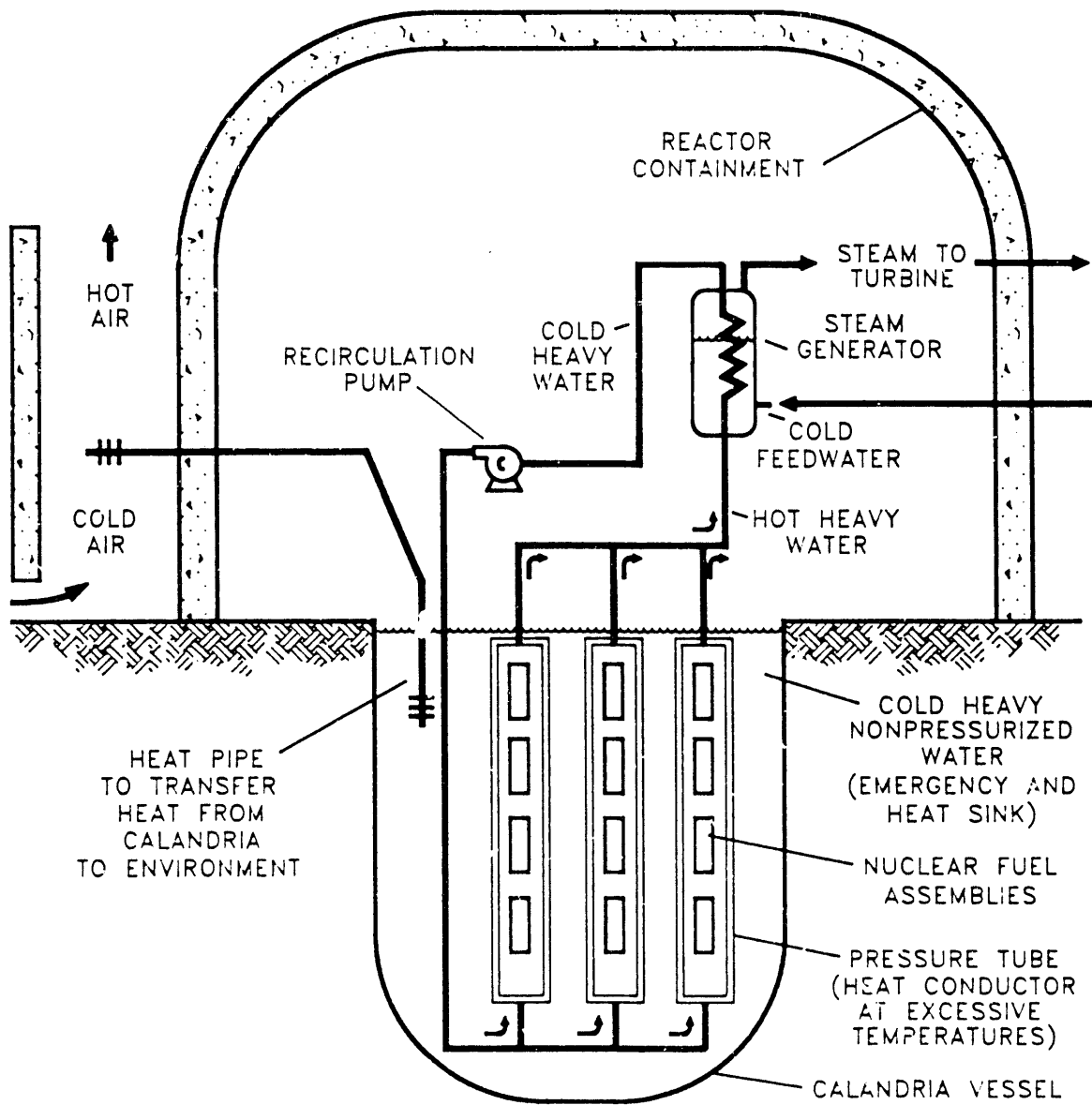

Fig. 2 Advanced CANDU Reactor concept.

The problem for the MHTGR is not safety but economics. Such small reactors have potentially high costs per unit of power output. The innovations here are new approaches to take a reactor that has many favorable safety characteristics and make it economical. Two approaches are being developed to improve economics.

1. **Mass Production.** The MHTGR is small compared with other power reactors and can, in large part, be shop fabricated. Mass production shop fabrication is less expensive than field fabrication.

2. **Gas Turbine.** An alternative version of the MHTGR, the MHTGR-Gas Turbine (MHTGR-GT), is being evaluated. Electric power is produced by running the hot helium from the reactor core directly into a helium gas turbine. Recent technical advances in gas-turbine power cycles have drastically reduced the costs of these power cycles. This is, in part, due to the very small size of the electric power generating equipment (turbines, heat exchangers, compressor) compared to the reactor and to other types of nuclear power plants (Fig. 3). Some estimates indicate that this may lower MHTGR-GT costs by as much as 26%, compared with the steam-cycle MHTGR. This is a major economic improvement [GCRA, 1990; Yan, 1991]. The costs for this option compared to more conventional designs of MHTGRs are the increased development cost and development time. This new technology is a result of jet engine developments in the aviation industry and elsewhere.

The MHTGR is an old reactor concept in which rapid improvements in nonnuclear manufacturing and power equipment have significantly reduced power plant costs. The unanswered question is if these major improvements are sufficient to make the reactor economically competitive. Appendix C.3 provides additional information.

4.1.3.2 Technical Description

The MHTGR core is made of very high-temperature graphite (ceramic) fuel elements. Helium gas is blown through the reactor core, the hot gas is used to generate steam in a steam generator, and the helium is circulated back to the reactor core by a helium blower. The safety system of the MHTGR is based on the geometry of the reactor core (Fig. 4). If the reactor is small enough and overheats, the heat can be conducted out through the vessel walls without overheating the nuclear fuel in the center of the reactor. The MHTGR is made as large as possible, while still allowing this method of cooling. This is the same foolproof system used to ensure safety in many research reactors.

4.1.4 Analysis

The new technologies use the old technologies as a foundation. Large-scale tests have clearly demonstrated the technical feasibility of PIUS and the MHTGR. The Advanced CANDU is in somewhat earlier stages of development. The next step for PIUS is to be a first-of-a-kind reactor to demonstrate economics and reliability. The status of the MHTGR is less clear. Steam-cycle demonstration MHTGR economics may be dependent on serial production, with the difficulty being initiating serial production. The MHTGR-GT may be economical at lower manufacturing rates, but significant development work is required. The

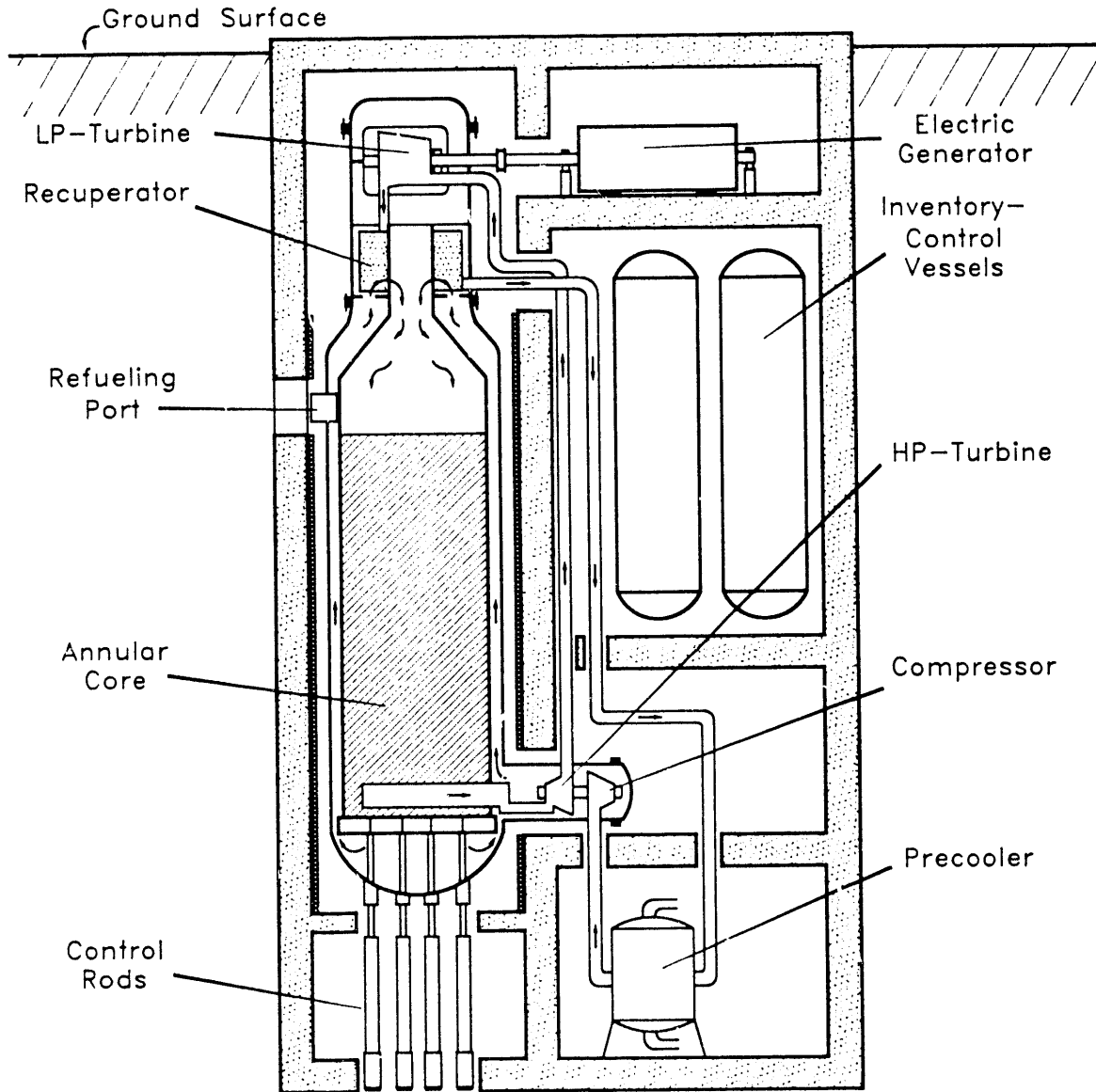

Fig. 3. MHTGR-GT Module.

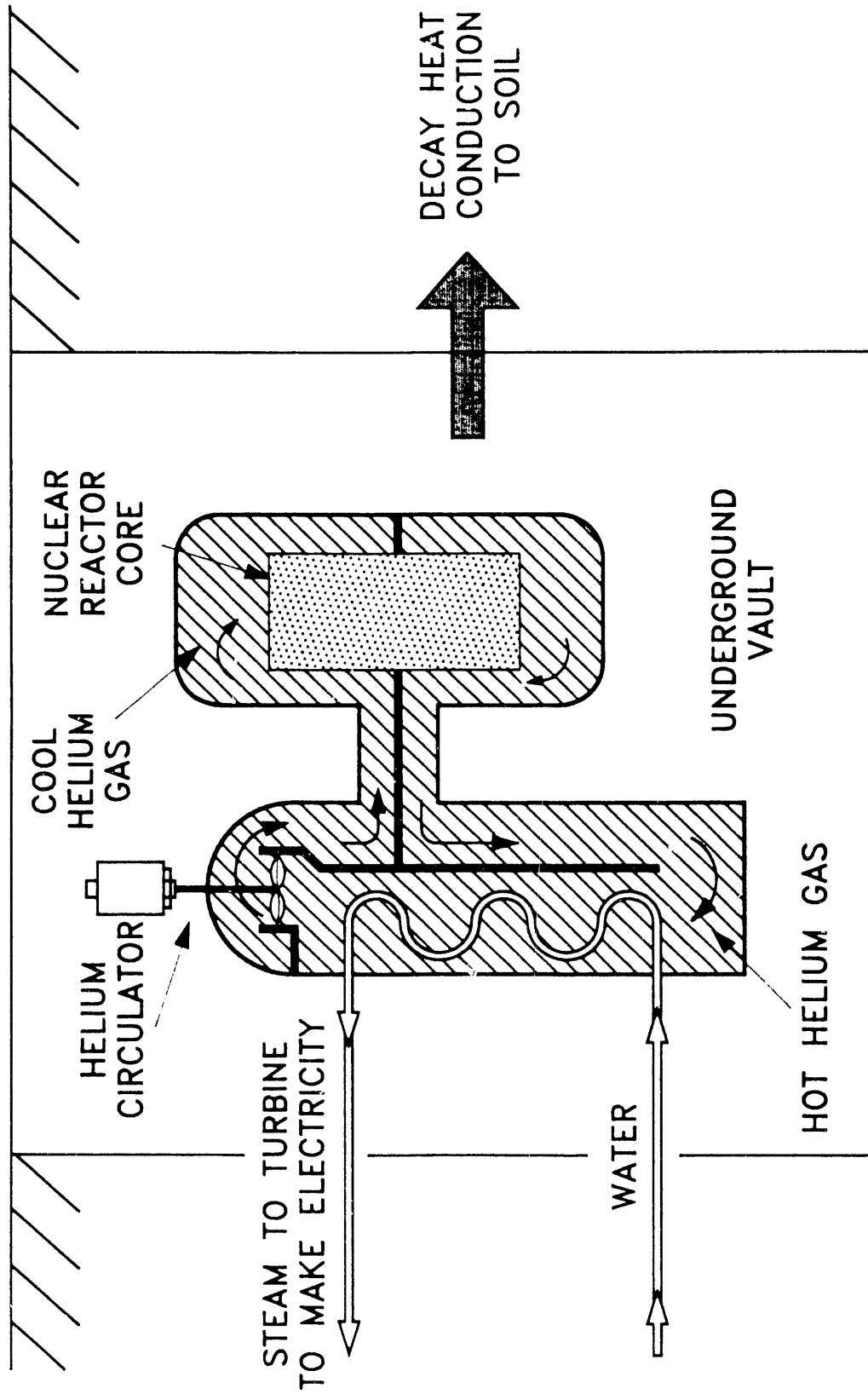

Fig. 4. Modular High-Temperature Gas-Cooled Reactor.

new proposed production reactor for the U.S. may be the critical bridge to commercial deployment.

4.2 SUPERCONTAINMENTS

4.2.1 Approach

Reactor containments have been a standard feature of nuclear power reactors. If there is a reactor accident, the containment building prevents the release of radioactive gases and aerosols to the biosphere. The success of the containment system at TMI and the consequences of the lack of a containment system at Chernobyl have provided strong experimental and political support for using the concept of a containment. This history has resulted in a parallel effort by part of the international nuclear power community to develop supercontainments—a technology based on passive and inherent safety.

4.2.2 Technical Description

Two technical developments have created the possibility of supercontainment systems.

1. Better containments. Historically, containments were designed to withstand a "design-base" accident. Super containment concepts are designed to protect against all types of accidents, including very low probability accidents, such as steel pressure vessel failure. If the accident is possible, the containment is designed to withstand it. A pure deterministic (rather than probabilistic) philosophy is used in design. Experience and elaborate field tests have created a real understanding of how accidents progress. This understanding allows designs to be based on detailed knowledge of accident conditions, not rough estimates. Figure 5 shows a representative German design.

2. Lower Accident Source Term. The danger to the public is not a reactor core meltdown and creation of a liquid pool of radioactive metals and oxides on the floor of the reactor building but the creation of radioactive gases and aerosols that are very hazardous if they escape via air to the environment (i.e., Chernobyl). Modifying reactor designs can reduce the creation of radioactive gases and aerosols if the reactor core melts down. This reduction of source term reduces radioactive releases after an accident, regardless of whether the reactor has a containment building or the containment building functions. Examples of such designs include:

- Nonzirconium-clad nuclear fuels that do not generate chemically explosive hydrogen during an accident (TMI safety problem); and
- Core Melt Source Reduction Systems (COMSORs) that incorporate core melt materials after an accident with special under-the-reactor-floor materials to produce a special high-level waste "glass" that does not release significant radioactive aerosols and gases to the containment buildings.

Appendix C provides a more detailed description of these options.

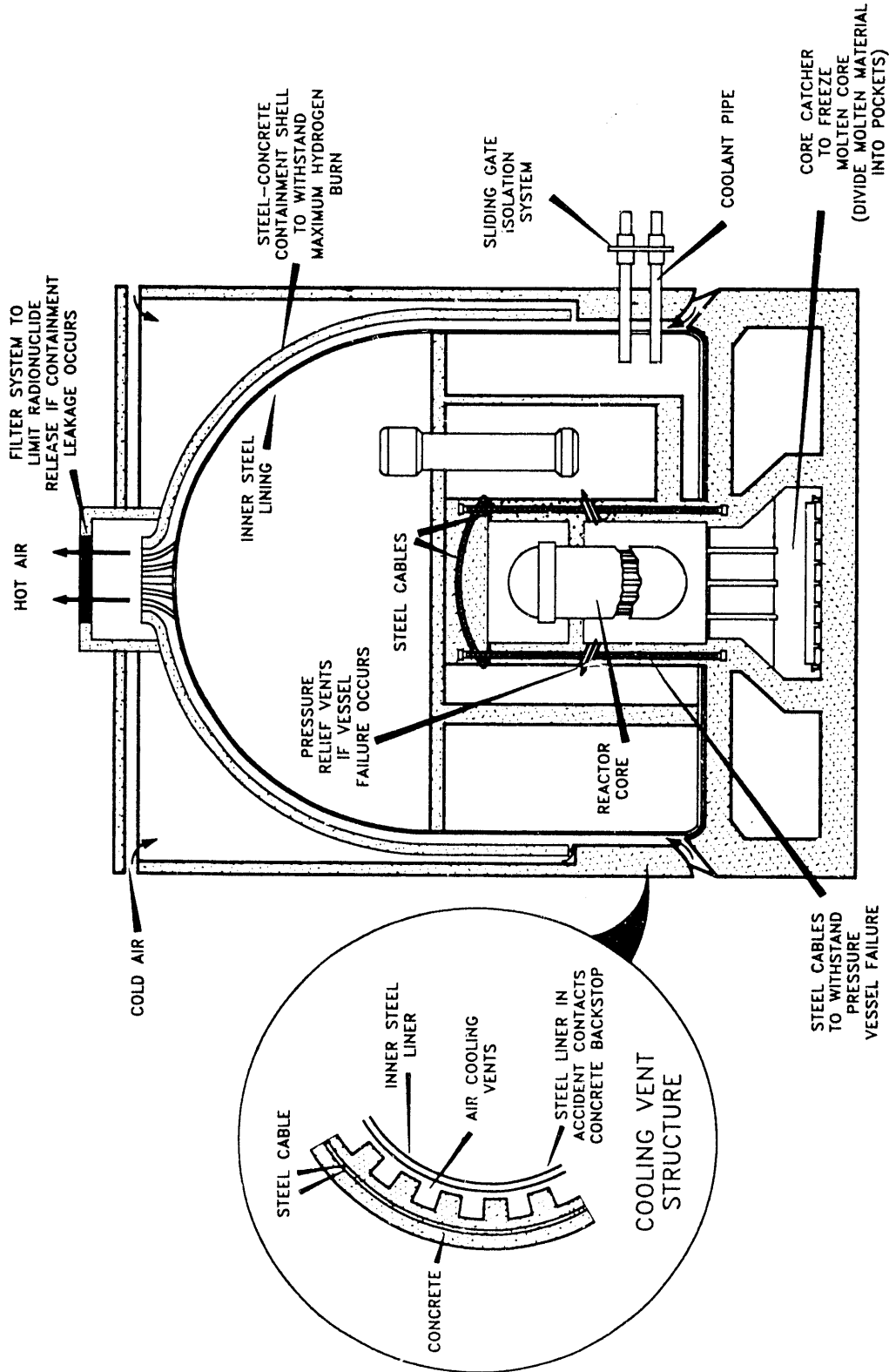

Fig. 5. Advanced containment structure.

4.2.3 Assessment

The interest in supercontainments is a result of three new influences: (1) the perspective in parts of Europe, since the Chernobyl accident, that a reactor accident with land contamination is absolutely unacceptable; (2) the recognition that supercontainments may not be as expensive as first thought; and (3) the technical discovery that with proper design the generation of radioactive gases and aerosols in containment can be radically reduced, capping maximum accident consequences.

5. WHO IS WORKING ON ADVANCED OPTIONS?

5.1 CANADA

5.1.1 Technical Programs

Atomic Energy of Canada Limited (AECL) at Chalk River has initiated the Advanced CANDU Project. Funding has been scheduled to rise to ~\$6 x 10⁶ per year, but the long-term emphasis on the program is uncertain because of the following conflicting (bad/good) events: (1) the election of a semi-antinuclear party as the majority party in Ontario (a major funding source), and (2) the recent sale of CANDU reactor to South Korea.

The program has made major technical breakthroughs. AECL is developing a passive cooling system for CANDU reactors, which is applicable to any size CANDU reactor and provides very high protection against catastrophic events. The passive reactivity control program has also made progress.

5.1.2 Assessment

The technical innovations made at Chalk River may fundamentally improve the long-term perspectives of CANDU. The technical innovations have two advantages over technologies for other types of PRIME reactors.

1. In principle, any size heavy-water reactor can be built.
2. It may be possible to implement the technology piece by piece into new CANDU reactors.

The technical uncertainties are somewhat larger than with other mainline PRIME reactor concepts because of the earlier stage of development.

5.2 FRANCE

5.2.1 Technical Programs

5.2.1.1 Water-Cooled Reactors

In 1990, the Commissariat A L'Energie Atomique (CEA), the French atomic energy commission, initiated a \$20 x 10⁶ per year research program to investigate long-term advanced technologies such as passive and inherent safety for light-water reactors (LWRs). The program is an exploratory effort, not a program to develop a specific technology for a specific reactor in a specific time. If new technologies look useful, separate development programs would be initiated. The program includes a significant effort on passive technologies to cool nuclear power reactors in accident conditions and advanced LWR fuels with advanced clad materials. The advanced clad materials would provide two benefits: (1) the economic benefit of fuels with higher burnup, and (2) the safety benefit of nonzirconium fuels that would not chemically react with water to produce hydrogen in an accident (see Section 4.2 on containments).

5.2.1.2 Modular High-Temperature Gas-Cooled Reactor

Two organizations are studying MHTGRs in France [MIT, 1991]—CEA and Framatome, the French reactor vendor. The small CEA studies are part of a recently initiated larger study to evaluate future nuclear power options. The Framatome study is a larger vendor design study to evaluate the economic and commercial viability of the gas-turbine MHTGR.

The Framatome study includes the participation of various French industrial companies to evaluate specific components and design features. Alternative designs are being evaluated in terms of technical development requirements, manufacturability, and economics. Evaluations include use of French PWR pressure vessel fabrication technology to fabricate equivalent MHTGR steel pressure vessels (same types of steel would be used). The technical and economic bases for a decision on whether to initiate a full-scale development program should be available in several years.

5.2.1.3 Supercontainments

There are several programs [MacLachlan, 1991] to examine advanced containment systems, particularly those designed to reduce the source term inside the containment. This work is strongly supported by the French regulatory agency, Nuclear Installations Safety Directorate (DSIN).

5.2.2 Assessment

The French nuclear power programs have been highly successful, with significant support in France for continued use of nuclear power. The technical programs are driven by economic issues, with a bias for advanced technologies that have the characteristics of simultaneously improving economics and safety. The CEA and Framatome programs have different timescales. The CEA program places more emphasis on development of advanced reactors to replace the first generation of PWRs when these reactors are decommissioned (~20+ years). The Framatome program has a more near-term perspective of ~10+ years.

The French perspective includes the following. The conventional PWRs in sizes from 900 to 1400 MW(e) per reactor are, by large margins, the reactors of choice based on economics. These reactors produce low-cost electricity. The large PWR is equivalent in safety to other nuclear options with appropriate technical support. Considerable future improvements in the technology are possible [MacLachlan, 1991]. The economic limitation of the PWR is that it is not economical in smaller sizes. This limits the use and sale of PWRs to those few countries with large electric demands and large electric grids.

While the absolute economics of smaller reactors is uncertain at this time, the gas-turbine MHTGR (based on vendor studies) appears to be the lowest-cost option for smaller reactors. If an economic gas-turbine MHTGR can be built, there are two markets:

1. The export market for smaller nuclear power plants.

2. The special-application market in which the unique high-heat rejection temperature of the gas turbine MHTGR gives it special economic advantages. These include: (1) combined electricity and water desalting, (2) combined electricity and district heat, and (3) electric production with dry cooling (a power plant with no water consumption). These applications may be internal or external markets.

The overall perspective is that the large PWR and the gas turbine MHTGR are complimentary reactor options for different market segments. The primary emphasis will be on the large PWR with a near-term emphasis on evolutionary PWR reactor designs by the reactor vendor Framatome.

5.3 GERMANY

5.3.1 Technical Programs

5.3.1.1 High-Temperature Gas-Cooled Reactor

At one time, Germany had a relatively large HTGR program with the emphasis initially on large reactors and later on smaller reactors. Several experimental and demonstration HTGRs were built, but all are currently shut down. The industrial program is rapidly shrinking, but there is a continued effort to develop the base technology at Forschungszentrum Julich, a government laboratory.

5.3.1.2 Supercontainments

Germany currently is investigating supercontainments for future reactors. The major technical effort is at Kernforschungszentrum Karlsruhe, but several industrial organizations are also participants. The development has included relatively detailed engineering analysis of advanced concepts with domestic and foreign technical reviews of proposed designs.

The initial cost estimates for supercontainments indicate small impacts on total reactor costs (<5%) under German conditions. This partly reflects the capabilities of current German containment systems, including their requirements to withstand extreme aircraft accidents and the conservative designs to withstand internal accident pressures.

5.3.2 Assessment

The political impact of the Chernobyl accident and the problems with Soviet-designed nuclear power plants in the former East Germany has made nuclear power highly controversial. This has encouraged development work on supercontainment systems for power reactors as a mechanism to improve support for nuclear power. There are two factors that encourage German development in this direction.

1. German reactors have an excellent operating record and have been economical in operation. There is strong support for the base technology by the vendor and the utilities.

2. Historically, Germany has emphasized the importance of containment systems for protection of the public. The success of the containment system in preventing the release of radioactivity at TMI, and the lack of containment on Chernobyl and other Soviet reactors has reinforced this early direction of German reactor programs.

5.4 ITALY

5.4.1 Technical Programs

5.4.1.1 Light-Water Reactors

After the Chernobyl accident, the Italian government shut down its three operating nuclear power plants because of perceived safety concerns, and it canceled the construction of those nuclear power plants under way. In 1988, the National Energy Plan (NEA, 1991) banned the construction of new nuclear power plants for 5 years but called for investigation of advanced nuclear power plants with significantly higher levels of safety that incorporated passive and inherent safety features.

The Italian government, the national utility, and major industrial organizations initiated a program to evaluate advanced reactors with improved safety characteristics. The evaluation is to be completed by the end of the moratorium in 1994 and involves an expenditure of $\sim \$60 \times 10^6$ by the government, an equivalent amount by the utility, plus industrial support. If approved by the government, the best reactor, based on the evaluation, would then be built in Italy. Three LWRs were chosen for detailed study: (1) the Simplified Boiling-Water Reactor (SBWR), (2) the Advanced Passive-600 Reactor (AP-600), and (3) the PIUS Reactor [Pedersen, 1991]. The SBWR and AP-600 are evolutionary technology reactors and are discussed in Appendix D.

The PIUS reactor is a modified PWR (see Sect. 5.8) being developed by the Swedish/Swiss company ABB. In Italy, an industrial consortium—Consorzio Pius [Financial Times, 1991; Barabaschi, 1991]—was formed to support PIUS reactor development and sales in Italy. The consortium partners are ABB (60%), Ansaldo (25%), and Fiat Componentie Impianti of Italy (15%). Major engineering planning and costing studies of PIUS are under way to support the Italian evaluation of future reactor options. In addition to PIUS, Ansaldo is evaluating an internally developed derivative PIUS concept called the Inherently Safe Immersed System (ISIS) Reactor [Cinotti, 1991; Amato, 1991].

5.4.1.2 Supercontainments

Italy has initiated significant programs to develop advanced containment systems, and much of this work is associated with government agencies. The goals are to ensure avoidance of land contamination, with no need for evacuation planning, and to provide time after an accident for response of the central authorities.

5.4.1.3 Modular High-Temperature Gas-Cooled Reactor

Italy is following work on MHTGRs as a long-term reactor option [NEA, 1991].

5.4.1.4 Other

There are several significant university and laboratory programs examining advanced reactors with passive and inherent safety [Universita, 1989].

5.4.2 Assessment

The Chernobyl accident and resultant radioactive fallout in northern Italy has been the central factor in defining Italian nuclear policy. That policy includes a major emphasis on developing reactor technologies that minimize the potential for land contamination in the event of an accident. Simultaneously, there are strong pressures for the use of nuclear power. Italy is almost totally dependent on foreign oil and natural gas for electric production, which results in relatively high-cost electricity, balance of trade difficulties, and strategic concerns about the almost total dependence on imported energy.

Based on operating experience, the Italian utility has a strong preference for water-cooled reactors. Both the government and utility have an interest in supercontainments, but the choice of the next reactor will be difficult for the utility and the government. The PIUS reactor has more advanced safety systems than its competitors; but, unlike the alternatives, it may require a demonstration plant and 7 or 8 years before the utility would commit to multiple nuclear power plants.

5.5 JAPAN

5.5.1 Technical Programs

5.5.1.1 Light-Water Reactors

The Japan Atomic Energy Research Institute (JAERI), in cooperation with various industrial groups, is investigating a family of steel pressure vessel PIUS-type reactors called System Integrated Pressurized Water Reactors [NEA, 1991]. Different reactor sizes and plant layouts are being compared. Investigations include both analytical and experimental work. Plant concepts up to 1100 MW(e) and consisting of two reactors in a single containment building are being evaluated on the basis of feasibility and economics.

5.5.1.2 High-Temperature Gas-Cooled Reactor

Japan has had a long-term program to develop HTGR technology. The program orientation has been development of very high-temperature gas-cooled reactors to provide high-temperature process heat to the steel and chemical industries. Currently, Japan is constructing a 30 MW(t) very high-temperature gas-cooled reactor called the High-Temperature Test Engineering Reactor (HTTR) with an expected completion date of 1995 [NEA, 1991]. They are leaders in several HTGR technologies, including advanced fuels (zirconium carbide-coated fuels) and high-temperature alloys for internal reactor components.

The center of HTGR work is at the JAERI where the HTTR project is being built. JAERI, the reactor vendors, and the utilities are involved in a variety of different HTGR studies.

5.5.2 Assessment

Japan has made no commitment to PRIME reactors. At the same time, they are very rapidly developing the base technologies and have an excellent strategic position to implement the technologies quickly if a commitment is made. In particular, the technology (fuels and high-temperature materials) being developed for the very high-temperature MHTGRs is exactly what is required for the gas-turbine MHTGR.

5.6 NETHERLANDS

5.6.1 Technical Programs

The Netherlands has initiated [ANS, 1991] a \$70 x 10⁶ new multi-year program for investigation of advanced power reactor concepts and waste management concepts. This includes a 3-year feasibility study of PIUS [Pedersen, 1991] and investigation of the Advanced CANDU Project.

5.6.2 Assessment

The Netherlands currently has a nuclear moratorium on construction of new nuclear power plants before the year 2000. There is consideration that the policy may be changed when the government's term of office ends in 1994. The continued growth in electric demand and environmental issues are the major factors for reconsideration of nuclear power. One specific consideration in the Netherlands is the carbon dioxide greenhouse effect and its impact on ocean sea levels—an issue for this country and its system of dikes that keep out the ocean. Both PRIME reactors and supercontainments will receive priority in future nuclear power studies.

5.7 SOUTH KOREA

5.7.1 Technical Programs

South Korea has initiated its own studies on the PIUS PWR [Pedersen, 1991]. It has also followed work on the Advanced CANDU Reactor.

5.7.2 Assessment

South Korea has a long-term interest in advanced reactors for its own internal use and as a potential long-term export. South Korea electric demand is rising rapidly. If South Korea was to attempt export of nuclear power plants in the future, the difficulty would be breaking into a market against many entrenched reactor vendors. New technology with major safety advantages would provide a competitive edge in such a market.

South Korea has recently bought PWRs from ABB Combustion [Weaver, 1991c] and a CANDU reactor from Canada [Anon, 1991]. Both purchases included significant technology transfer. The foreign vendors are also the vendors respectively developing PIUS and the Advanced CANDU Reactor. If South Korea chooses to develop one of these advanced reactors, it would be expected to be in partnership with its historic foreign partners.

5.8 SWEDEN

5.8.1 Technical Programs

The private company ABB [Pedersen, 1991] is developing the PIUS reactor at its research laboratories at Västerås, Sweden. PIUS was invented at this laboratory by K. Hannerz. Large-scale high-temperature, high-pressure test loops at these facilities have experimentally confirmed the technical feasibility of PIUS. Extensive engineering has been completed on the PIUS design, including extensive trade-off studies and economic evaluations. This work is continuing in cooperation with various ABB companies worldwide and other private companies.

While the PIUS concept was initiated and developed in Sweden, ABB is an international company with the goal of selling the reactor worldwide. ABB is the world's largest industrial equipment company [Hammes, 1991] with foreign subsidiaries in many countries (U.S. nuclear power subsidiary ABB Combustion). Historically, ABB nuclear power reactors have been the world's most reliable reactors [NW, 1991]. This provides significant credibility to the PIUS development program, which involves the participation of many subsidiaries and various foreign partnerships. For example, in the United States, ABB Combustion is involved in licensing review of PIUS by the U.S. NRC. In this context, PIUS reactor development is centered in Sweden but is an international effort involving multiple private companies.

5.8.2 Assessment

Sweden has a nuclear moratorium on building new nuclear power reactors and a policy to phase out existing nuclear power reactors. Initially, rapid phase out of existing nuclear power plants was planned, but these policies have been abandoned in a piecemeal fashion. There has been a slow, but steady, increase in public acceptance of nuclear power in Sweden. The reasons for the continuous change in policy include the following:

1. The very high reliability and high levels of safety of Swedish nuclear power plants.
2. The rapid advances in the Swedish radioactive waste programs, including construction and operation of (1) a Monitored Retrievable Storage facility for long-term storage of spent fuel, and (2) a low-level/intermediate-level radioactive waste disposal facility in caverns under the Baltic Sea. Sweden is the only country in the world that has managed to build and operate multiple large-scale waste management facilities in the 1980s. The international recognition of the advanced nature of these facilities has impacted domestic public acceptance.

3. The fact that nuclear power is much more economical than alternative energy sources. This has resulted in a combined program of major industries (nonnuclear) and labor unions supporting nuclear power for economic reasons.
4. The concerns about environmental effects.

The Swedish nuclear industry priorities have been (1) existing plants, (2) waste management, and (3) new nuclear power plants. The issue of new power plants has not been emphasized in public debates because of the initial near-term government policies to phase out existing facilities. The development of PIUS is considered one way to break the deadlock over ordering new nuclear power plants after a general consensus is reached that existing power plants can operate to the end of their useful lives. A radical improvement in reactor safety with a new technology is viewed as a way to allow politicians and political parties to back away from strong antinuclear positions on the basis that the technology has changed, and therefore, should be reevaluated.

5.9 SWITZERLAND

5.9.1 Technical Programs

5.9.1.1 Light-Water Reactors

Switzerland has a small program to develop a district heating reactor, called Geysler®, at the Paul Scherrer Institute. The primary emphasis is on district heat, but the reactor concept, with some of the characteristics of the PIUS reactor, can produce electricity. Full-scale, nonnuclear thermal hydraulic tests have demonstrated the underlying principles of operation [Revesz, 1988]. The technology is different than other concepts that have been proposed and may allow development of a power reactor. With PRIME safety characteristics, the reactor concept has been reviewed by Swiss regulatory authorities, who have stated that it could be licensed for unattended operations in populated areas when used as a district heating reactor.

5.9.1.2 Modular High-Temperature Gas-Cooled Reactor

The Swiss MHTGR program has been a long-term cooperative effort with Germany. Events in Germany plus events in Switzerland have left its future uncertain (see Sect. 5.3)

5.9.2 Assessment

In late 1990, the Swiss adopted a 10-year moratorium for any level of licensing of a nuclear reactor [NEA, 1991]. This was a consequence of the Chernobyl accident fallout, and it has stopped the Swiss nuclear program. New directions have not yet been defined, but the starting point for future programs is the Swiss "Reactors-2000 Study." The preliminary results of this study, which included analysis of opinions of industrial, governmental, and other leaders indicate only 10% support for the safety philosophy (active safety) used in current power reactors.

The Swiss have limited national energy resources (hydropower), thus creating significant incentives to continue with nuclear power. These current operating reactors have been highly reliable and economical. (The moratorium does not impact existing reactors.) Given the preliminary results of the Swiss "Reactor-2000 Study," it appears likely that serious consideration will be given to both PRIME reactors and supercontainment.

5.10 UNION OF SOVIET SOCIALIST REPUBLICS

5.10.1 High-Temperature Gas-Cooled Reactors

In response to the Chernobyl accident, the Soviet Union accelerated its development program on MHTGRs. Issues of reactor safety were the driver for the change in direction. This included agreement with Germany to build a Russian-German MHTGR at Dimitrovgrad, USSR. The economic difficulties have delayed indefinitely the construction of this prototype reactor.

5.10.2 Assessment

The Chernobyl accident plus the other political changes within the Soviet Union have stopped the Soviet nuclear program and made it difficult to define the program. It is equally difficult to define future directions. Unlike the TMI accident, there are three additional complications with the Chernobyl accident:

1. The Chernobyl accident has, in part, become a symbol of the failure of the government, not just the power industry.
2. The political and economic changes in the Soviet Union have disrupted normal economic activity, including those associated with nuclear facilities.
3. With the independence of Eastern European countries, there have been continued shutdowns of Soviet-designed LWRs in Eastern Europe. The impact of these most recent developments is not yet known.

There is a clear interest in reactors that are less sensitive to operator error. It is unclear whether the economic or institutional resources exist to effectively implement an advanced nuclear program. Many of the available resources are focused on upgrades of existing reactors.

5.11 UNITED STATES

5.11.1 Technical Programs

5.11.1.1 Light-Water Reactors

In the United States, ABB Combustion has submitted the PIUS Preliminary Safety Information Document to the U. S. NRC and will support the application in front of the NRC. ABB Combustion is one of the four traditional reactor vendors in the United States

and is a wholly owned subsidiary of ABB. This licensing activity is part of a worldwide effort to develop the PIUS reactor. The NRC review is expected to be completed in 1993 [Weaver, 1991b; Pedersen, 1991]. A number of utilities have formally expressed to the NRC their support of PIUS and encouraged prompt action by the NRC [Fogelström, 1989].

5.11.1.2 Modular High-Temperature Gas-Cooled Reactor

The United States government has supported a long-term High-Temperature Gas-Cooled Reactor development program with funding levels of \$15 to 20 x 10⁶ per year. Current technical efforts focus on the MHTGR with a baseline concept of four reactors per station with some equipment in common. A range of reactor sizes is being considered from 350 to 450 MW(t) per reactor. The corresponding electrical outputs per reactor would vary from 135 to 173 MW(e). The current version uses a Rankine (steam) power cycle. The development work is under way at General Atomics (San Diego) and at Oak Ridge National Laboratory (ORNL).

A group of utilities has formed Gas-Cooled Reactor Associates (GCRA) to assist development. GCRA has also evaluated the gas-turbine MHTGR and encourages its development because of its potentially lower costs.

In the United States, there is also a program to build a new production reactor to produce tritium and other materials. Two reactor concepts are being developed: (1) an MHTGR and (2) a low-pressure heavy-water reactor. At the end of 1991, a decision will be made on which type of production reactor to build. The MHTGR production reactor would produce electricity and is similar in design to the commercial reactor. A decision to build the production MHTGR would result in the rapid development of commercial MHTGR technology. The major companies involved in development of the reactor are General Atomics of San Diego and ABB Combustion. If the MHTGR is chosen, the following will occur: (1) most of the MHTGR technology will be developed, (2) a fuel cycle infrastructure for the MHTGR will be created, (3) licensing issues will be addressed, (4) the technology will be demonstrated, and (5) a cadre of people knowledgeable in the technology will have been assembled.

5.11.1.3 Supercontainments

There is currently no significant effort to develop supercontainments in the United States; however, there are regulatory activities in this area. The Advisory Committee on Reactor Safety (ACRS) to the NRC recently recommended that future reactor containments be designed to withstand a wider variety of accidents [Ward, 1991]. These proposed requirements extend significantly beyond current requirements, but how far requirements will be extended is currently unknown.

5.11.1.4 Other

Small research efforts on technologies applicable to PRIME LWRs are under way at ORNL, the Massachusetts Institute of Technology, and Ohio State University. Two specific activities at ORNL are noteworthy:

1. A compendium of passive and inherent safety technologies for water-cooled reactors [Forsberg, 1989].
2. Discovery of multiple water-cooled reactor concepts with PRIME safety. For several years, the only PRIME LWR concept was PIUS. The discovery of multiple classes of such technologies indicates the existence of many technical options.

5.11.2 Assessment

There is no consensus on future directions of nuclear power in the United States. In part, this reflects the organization of the utility industry, which consists of several hundred private, cooperative, and government owned utilities. The federal government and Electric Power Research Institute perspective is that the next nuclear power orders will be for an evolutionary plant design LWR (General Electric Advanced Boiling-Water Reactor or Combustion System 80+ Pressurized-Water Reactor) or an evolutionary technology LWR (Westinghouse AP-600 PWR reactor or General Electric Simplified Boiling-Water Reactor). In the longer term, the federal government expects development of the MHTGR.

The previous perspective reflects the majority position of the utilities, but it is not a strongly held position by most utilities. There is a broad utility consensus that there will not be significant nuclear plant orders for 5 to 10 years and then only if issues of licensing and public acceptance are addressed. This "wait-and-see" perspective of the utilities implies that major changes in utility perspectives are possible and likely in response to changing conditions.

There are several other noteworthy perspectives held by selected groups of utilities.

1. There is continued utility support for the MHTGR via the Gas-Cooled Reactor Associates consortium. Several utility members have expressed the perspective that a radical change in technology is a requirement for a significant rebirth of nuclear power in the United States.
2. A number of utilities have publicly supported PIUS, in particular, using NRC regulatory review to identify licensing issues and verify safety claims. This includes support from the largest private utilities with major nuclear programs [Fogelström, 1989].
3. Several utilities have expressed support for purchase of advanced reactors from foreign suppliers on the basis of the higher reliability of foreign units.

In the near term, the decision on what technology to use for the next production reactor may strongly influence directions for nuclear power. The new production reactor will be the largest nuclear development and construction project in the U.S. in the 1990s. If the MHTGR is chosen, it will rapidly accelerate development of the technology and make possible commercial development of the technology on a schedule only slightly behind that of more advanced LWRs. Success of a new production MHTGR, in terms of technology and resolution of licensing issues, would significantly increase utility support by elimination of the noneconomic uncertainties associated with the reactor.

6. CONCLUSIONS

Before the TMI accident, the technical question of whether a reactor could be built with PRIME safety characteristics was an unresolved academic issue. There was a broad consensus that water-cooled reactors were the preferred near-term reactor type and that the LMFBR would be needed in the long term to extend nuclear fuel sources.

Today, sufficient technical work has been completed to demonstrate that power reactors with PRIME safety characteristics can be built. The major questions in the international nuclear community are the necessity for and economics of such reactors. *There is no consensus on the future directions of nuclear power.* The answers to these questions will have major impacts on which companies and countries are leaders in the technology and use of commercial nuclear power.

7. REFERENCES

- ABB Nuclear Reactors, Inc., 1989. *PIUS*.
- ABB-Atom, 1989, *PIUS Preliminary Safety Information Document*.
- Amato, S., Monasterolo, U., Monti, R., Orazi, A., 1991. "Response of the Inherently Safe Immersed System (ISIS) Reactor to Accident Conditions," *SMIRT Seminar on Small and Medium Size Reactors*, New Dehli, India.
- American Nuclear Society, 1991. "Rising Power Demand May End Nuclear Moratorium," *Nuclear News*, 34(9):89.
- Anon, 1991. "South Korea Orders CANDU Reactor From Canada's AECL," *The Energy Daily*, 19(4):3 (Jan. 7, 1991).
- Arthur, W. B., 1990. "Positive Feedbacks in the Economy," *Sci. Am.* 262 (2):92.
- Barabaschi, S., 1991. "PIUS on the Move in Italy," *Nuc. Eng. Int.*, 36(443):52 (June 1991).
- Carnesale, A., 1981. *Presidents Nuclear Safety Oversight Committee*.
- Cash, 1991. "Lawrence Lidsky, PhD'62: Nuclear Engineer and Icon Basher," *Technology Review*, p.33 (May/June 1991).
- Cinotti, L. and Rizzo, F. L., 1991. "The Inherently Safe Immersed System (ISIS) Reactor," *SMIRT Seminar on Small and Medium Size Reactors*, New Dehli, India.
- Cook, J., 1985. "Nuclear Follies," *Forbes*.
- Financial Times, 1991. "ABB Strikes New Nuclear Joint Venture," *The Energy Daily*, 14(6):3, (Jan. 9, 1991).
- Fogelström, L., 1989. "Letter requesting Licensability Review of PIUS," Nuclear Regulatory Commission, Public File, T OPRP-ENVASEAB 89-1005, 900529-DMC
- Forsberg et al., 1989. Proposed and Existing Passive and Inherent Safety-Related Structures, Systems, and Components (Building Blocks) for Advanced Light-Water Reactors, ORNL-6554.
- Forsberg, C. W., and Weinberg, A. M., 1990. "Advanced Reactors, Passive Safety and Acceptance of Nuclear Energy," *Ann. Rev. of Energy*, 15:133.
- Gas-Cooled Reactor Associates, 1990. *GCRA Scoping Assessment of the MTHGR-GT*, San Diego.

- Golay, M. W., 1988. "Light-Water Reactor (LWR) Innovation Needs in the United States: The Massachusetts Institute of Technology LWR Innovation Project," *Nucl. Tech.* 80, 42.
- Goldman, J., 1990. "Bad News in Buenos Aires," *Bill of At. Sci* 8(2).
- Hammes, S. and Teitelbaum, R., 1991. "The Fortune Global 500," *Fortune*, 124(3):270.
- Hannerz, K., Nilsson, L., Pedersen, T., and Pind, C. 1990. "The PIUS Pressurized-Water Reactor: Aspects of Plant Operation and Availability," *Nucl. Technol.* 91(1):81.
- Hansen, K. F., Behnke, W. B., Cousin, S. B., Evans, E. A., Olander, D. R., Ransom, V. H., and White, J. D., 1990. *Japanese Technology Evaluation Center Report on Nuclear Power in Japan*, PB90-215724.
- Hibbs, M., 1990. "GDR Orders Greifswald Shut: GRS Hits Operational Safety," *Nucleonics Week*, 31 (23):2.
- Kessler R., 1990. "Atucha-1 Shutdown for 40 Days Set for More Repairs in July," *Nucl. Week*, 31 (24):12.
- Lanning, D. D., White, J. D., Beltraechi, L., Best, F. R., Bhatt, S., Easter, J. R., Oaks, L. C., Sudduth, A. L., 1991. *Japanese Technology Evaluation Center Panel on European Nuclear Instrumentation and Control*, (Draft).
- Lundberg, Bo K. O., 1963. "Speed and Safety in Civilian Aviation," Aeronautical Research Institute of Sweden, Report 95, Stockholm, Sweden.
- MacLachlan, A., 1991. "Definition of France's Future Reactor Gets Underway in Earnest," *Nucleonics Week*, 32(25):12.
- Martinez, J. M., Aragonés, J. M., Minquez, E., Perlado J. M., and Velarde, G., 1990. "An Analysis of the Physical Causes of the Chernobyl Accident," *Nucl. Tech*, 90, 371.
- Massachusetts Institute of Technology, 1991. *International Workshop on the Closed Cycle Gas-Turbine Modular High-Temperature Gas-Cooled Reactor*, June 17-19 (In Press).
- Nuclear Energy Agency, 1991. *Small and Medium Nuclear Reactors: What Prospects* (In Press).
- Nucleonics Week, 1991, page 8 (Feb. 14, 1991).
- Pedersen, T., 1991. "Europe's New Reactors," *Physics World*, 4(8):37.
- Revesz, Z., 1988. "Nuclear Reactors with Enhanced Safety Features: The Geyser System," *International Conference on Enhanced Safety of Nuclear Reactors*, George Washington University, Institute for Technology and Strategic Research, ITSr-088.

- Turinsky, P., Baron, S., Burch, W. D., Corradini, M., Lucas, G., Matthew, R. B., and Uhrig, R. F., 1991. *Western European Nuclear Power Generation*, Foreign Applied Sciences Assessment Center (FASAC), Science Applications International Corporation, McLean, Virginia (In Press).
- Universita' Di Roma "La Sapienze," 1989. *Multipurpose Advanced Reactor inherently Safe (Mars)*, Dipartimento Di Energetica.
- Utility Data Institute, 1988. *1987 Production Costs Operating Steam Electric Plants*, UDI-011-88.
- Ward, D. A., 1991. Letter: "Proposed Criteria to Accommodate Severe Accidents in Containment Design," United States NRC Advisory Committee on Reactor Safeguards (May 17, 1991).
- Weaver, D., 1991a. "Utility Chiefs Spar Over the Best Way to Revive Nuclear," *The Energy Daily*, 19(44):1.
- Weaver, D., 1991b. "NRC's Realism Delays Nuclear Revival," *The Energy Daily*, 19 (113):1.
- Weaver, D., 1991c. "ABB Wins \$200 Million Korean Nuclear Jobs," *The Energy Daily*, 19 (140):1.
- Weinberg, A. M., 1989. "Engineering in an Age of Anxiety," *Issues in Science and Technology*, VI(2):37.
- Yan, X. and Lidsky, L. M. 1991. "Design Study for an MHTGR Gas-Turbine Power Plant," *53rd Am. Power Conf.*, Chicago.

APPENDIX A: DIRECTIONS IN REACTOR DEVELOPMENT

A.1 INTRODUCTION

Current and future reactors may be divided into four classes—evolutionary plant reactors, evolutionary technology reactors, breeder (liquid-metal) reactors, and PRIME reactors—when defined by the goals of the designers.

A.2 EVOLUTIONARY PLANT REACTORS

The evolutionary *plant* designs, exemplified by the nine reactors listed in Table A1, are similar in overall plant design to existing LWRs or Canadian deuterium-uranium reactors (CANDUs) but have refinements and modernization of the designs. Their safety, like that of their predecessors, depends on a variety of active safety systems with power supplied by diesel generators or equivalent power sources. In the event of an accident, the safety systems must start up and continue to operate to prevent reactor core damage. Water-cooled reactors have been built with various types of pumps, valves, motors, control-rod drives, containments, and other components/systems. There is now sufficient operating experience to judge which variations in design work the best. These designs reflect this rapidly increasing experience base and are the nuclear plant equivalents to evolutionary designs in cars and aircraft. The best of them have estimated core melt probabilities approaching 10^{-6} per year for expected design events [Wolfe and Wilkins, 1989].

A.3 EVOLUTIONARY TECHNOLOGY REACTORS

Evolutionary *technology* water-cooled reactors (Table A1) are proposed advanced reactors that use the technology of current reactors (components and systems) but have significant changes in plant design, particularly the safety systems. Most of the proposed safety systems for these reactors require power to initiate safety operations (such as to open a valve) but do not require power for continued operation. Safety system operation after initiation is passive. This is a key distinction between these designs and the evolutionary *plant* designs and is a significant advance in safety technology. These changes in design reflect two experiences. First, all of these designs were initiated after the Three Mile Island accident and reflect the technical lessons learned. Second, the new designs reflect the operating experiences of current plants. That experience has shown which features in a plant that are difficult to operate or expensive and need to be changed. Appendix D describes these reactors in further detail.

A.4 BREEDER REACTORS

Breeder reactors, of which the dominant type is the Liquid-Metal Reactor (LMR), convert cheap, fertile, nonfuel materials such as ^{238}U into valuable fissile fuels such as ^{239}Pu . With increasing estimates of the world's resources of uranium, the time when a breeder may be needed for fissile fuel production has moved further into the future. These changing general conditions, modified by local needs, have resulted in national LMR programs going in new directions. All breeder reactor work is supported by national governments.

Table A1. Advanced reactors

| Name | Type | Size/MW(e) | Countries | Lead organizations | Status | References |
|--|------------------|------------|---------------|--------------------------------------|---------------------|--|
| <u>Evolutionary Plant Designs</u> | | | | | | |
| N4 | PWR | 1400 | France | Framatome | Construction | IAEA, 1988 |
| Sizewell B | PWR | 1250 | Great Britain | Central Electric Generating Board | Construction | IAEA, 1988 |
| Advanced Boiling-Water Reactor | BWR | 1356 | Japan/U.S. | Hitachi/Toshiba/G.E. | Design/construction | Wolfe & Wilkins, 1989; IAEA, 1988; Wilkins et al., 1986 |
| Advanced Pressurized-Water Reactor | PWR | 1350 | Japan/U.S. | Mitsubishi/Westinghouse | Design | IAEA, 1988 |
| Advanced BWR 90 | BWR | 1050 | Sweden/Switz. | ABB*Atom | Design | IAEA, 1988 |
| Combustion 80Plus | PWR | 1280 | U.S. | ABB-Combustion | Design | IAEA, 1988 |
| VVER 88/92 | PWR | ~1000 | USSR | | Design | |
| CANDU 8 | HWR ^b | 900 | Canada | Atomic Energy of Canada, Ltd. | Design | IAEA, 1989 |
| CANDU 3 | HWR | 450 | Canada | Atomic Energy of Canada Ltd. | Design | IAEA, 1989 |
| <u>Evolutionary Technology Designs</u> | | | | | | |
| Simplified Boiling-Water Reactor | BWR | 600 | U.S. | General Electric | Development | Wolfe & Wilkins, 1989; IAEA, 1988; McCandless & Redding, 1989 |
| Safe Integral Reactor | PWR | 300 | U.S./G.B. | ABB-Combustion Rolls Royce | Development | Teare, 1989 |
| Advanced Passive-600 | PWR | 600 | U.S. | Westinghouse | Development | Vijuk & Bruschi, 1988 |

Table A1. Advanced reactors (continued)

| Name | Type | Size/MW(e) | Countries | Lead organizations | Status | References |
|---|------|------------|-------------------------------|--------------------|---------------------------|--|
| Mitsubishi Simplified Pressurized-Water Reactor | PWR | 600/1200 | Japan | Mitsubishi | Development | Matsuoka, 1991 |
| Hitachi Small Boiling-Water Reactor | BWR | 600 | Japan | Hitachi | Development | Kataoka et al., 1988 |
| Toshiba 900 | BWR | 310 | Japan | Toshiba | Development | |
| System Integrated Pressurized-Water Reactor | PWR | 350 | Japan | JAERI ^c | Development | Sako, 1988 |
| CAREM | PWR | | Argentina | INVAP | Development | Nuc. Eng. Int., 1991 |
| <u>Breeder Reactors</u> | | | | | | |
| PRISM | LMR | 155 | U.S. | General Electric | Development ⁱⁱ | Chang, 1989; Berglund & Trippels, 1989 |
| European Fast Reactor | LMR | | France/G.B./ Germany | | Development | Cicognani et al., 1989 |
| <u>PRIME Reactors</u> <u>Water Cooled</u> | | | | | | |
| PIUS (Secure P ^o) | PWR | 640 | Sweden/Italy S. Korea/U.S. | ABB | Development | Forsberg et al., 1989; IAEA, 1988; Hannert, 1988 |
| ISER | PWR | 210 | Japan | U. of Tokyo | Research | Wakabayashi, 1985; IAEA, 1988 |

Table A.. Advanced reactors (continued)

| Name | Type | Size/MW(e) | Countries | Lead organizations | Status | References |
|--|------|------------|-----------|--------------------|--------------------------------------|--------------------------------|
| <u>PRIME Reactors</u> | | | | | | |
| <u>Water-Cooled (continued)</u> | | | | | | |
| Advanced CANDU Project | HWR | | Canada | Atomic Energy of | Research/Development Canada, Ltd. | |
| <u>Modular High-Temperature Gas-Cooled Reactor</u> | | | | | | |
| MITGR/U.S. | HTGR | | U.S. | General Atomics | Development | Lanning, 1989 |
| MITGR/German | HTGR | | Germany | Siemens/ABB | Research | Lanning, 1989; Varley, 1989 |
| MITGR/Gas Turbine | HTGR | | U.S. | MIT ^a | Research | Staudt & Lidsky, 1987 |
| <u>Molten Salt Reactor</u> | | | | | | |
| MSR | MSR | | USSR/U.S. | | Preliminary research | |

^a Asea Brown Boveri

^b HWR = Heavy-water reactor

^c JAERI = Japan Atomic Energy Research Institute

^d MIT = Massachusetts Institute of Technology

In Europe, the emphasis has been on integrating the various national programs into a coordinated European Fast Reactor Project [Cicognani et al., 1989; Turinsky, 1991]. The major partners are France, Germany, and the United Kingdom and the minor partners are Belgium and Italy. Program integration reflects both the general economic integration of western European nations into a single economic block and the viewpoint that the need for LMRs is further in the future than originally believed. The technical aspects of European programs have remained relatively constant.

In the United States, the LMR program has undergone major changes in direction [Chang, 1989; Berglund and Trippets, 1989; Lineberry et al., 1991; Berglund et al., 1991] with an emphasis on shop-fabricated, modular reactors with metal fuel and various passive safety systems. The major development program led by General Electric is for the Power Reactor Inherently Safe Module (PRISM[®]). Each module produces only 155 MW(e); 9 modules would be arranged in 3 identical 465 MW(e) power blocks for an overall plant net electrical rating of 1395 MW(e). The small size for this type of reactor makes design of passive safety systems somewhat easier. Argonne National Laboratory is developing the associated metal fuel and pyrochemical fuel cycle. This includes development of technologies to recycle all actinides (neptunium, plutonium, americium, and curium) in LMRs to reduce the quantities of long-lived radionuclides in the waste. This is to create the option of using LMRs as power reactors and waste management tools.

In contrast to earlier LMR prototype plants and designs, PRISM depends primarily on passive safety systems. These various systems depend on three characteristics of PRISM: (1) its relatively small size, (2) the large temperature difference between normal operating temperatures (~900°F) and the boiling point of sodium (~1800°F), and (3) the characteristics of the metal fuel. The ultimate decay heat removal system is the Reactor Vessel Auxiliary Cooling System (RVACS). If normal cooling systems fail, the sodium heats up to ~1100°F, heat radiates from the reactor vessel to the containment vessel, and the containment vessel is cooled by the natural circulation of air that bathes the containment vessel. This passive decay heat cooling system eliminates the need for active decay heat removal systems but requires that no thermal insulation be placed around the reactor pressure vessel. This results in a nominal heat loss of about 0.2% of the rated power during normal operations to the environment via decay heat removal systems that cannot be turned off. A second development of passive safety systems for LMRs has been the design of relatively small metal fuel reactor cores in which total power levels are limited below levels that cause core damage by the strong, inherent negative reactivity feedback of the reactor core. Inherent protection against many types of reactor overpower accidents was demonstrated in a series of experiments at the Experimental Breeder Reactor-II (EBR-II) in 1986 [Planchon et al., 1987]. These developments have not eliminated all types of overpower accidents that could theoretically occur in LMRs but have reduced the number of potential accidents.

A.5 PRIME REACTORS

The fourth class of reactors under development is PRIME reactors, in which the goals of the designers are radical improvements in safety and public acceptance with the potential for major improvements in economics. Because the goals are aggressive, new technologies are required for the reactor designs. Various advocates state requirements differently, but the

term PRIME provides a reasonable description of these goals. PRIME is an acronym for Passive safety, Resilient operation, Inherent safety, Malevolence resistance and Extended safety (see Appendix B).

There are fundamentally only two requirements to ensure reactor core integrity and, hence, reactor safety. The first requirement is to prevent excessive core power levels. The Chernobyl accident resulted from such a power excursion. The second is the ability to remove reactor heat under all circumstances, including reactor shutdown. When a reactor is shut down, the decay heat, although only a small fraction of full power, can destroy the reactor (such as occurred at TMI) if it is not removed. Based on the means for dealing with decay heat, three categories of PRIME reactors can be identified.

1. Decay heat can be removed from the reactor core by absorbing the heat in the reactor vessel and its contents. This is the basis for the Process Inherent Ultimate Safety (PIUS) LWRs in which the reactor vessel has a large volume of water and decay heat is removed from the reactor by boiloff of this inventory of water.
2. Decay heat can be removed from the reactor core by conduction of heat out of the walls of the reactor, reactor vessel, and structures to the ground and air. This is the approach used for the Modular High-Temperature Gas-Cooled Reactor, and in modified form for the Advanced Candu Reactor.
3. Decay heat can be removed from the reactor core by use of a liquid or gaseous reactor core and continuous processing of the fuel, so there are only small quantities of heat producing fission products in the reactor core at any one time. Modified versions of the Molten-Salt Breeder Reactor (MSBR) and various aqueous fueled reactors are examples. None of these fluid fuel reactor concepts are currently being developed.

A.6 REFERENCES

- Berglund, R. C. and Trippets, F. E. 1989. PRISM, The Plant Design Concept of the U.S. Advanced Liquid Metal Reactor Program, ANTO-SP065, *51st Am. Power Conf., Chicago*.
- Berglund, R. C., Magee, P. M., Boardman, C. E., and Gyorey, G. L. 1991. "Performance and Safety Design of the Advanced Light-Metal Reactor," *53rd Am. Power Conf., Chicago*.
- Chang, Y. I. 1989. "The Integral Fast Reactor," *Nucl. Technol.* **88**(2), 129-138.
- Cicognani, G., Broomfield, A. M., Lallement, R., and Marth, W. 1989. "The European Breeder Program," *Nucl. Technol.* **88**(2), 175-182.
- Forsberg, C. W., Moses, D. L., Lewis, E. B., Gibson, R., and Pearson, R., 1989. *Proposed and Existing Passive and Inherent Safety-Related Structures, Systems and Components (Building Blocks) for Advanced Light-Water Reactors*, ORNL-6554, Oak Ridge National Laboratory, Oak Ridge, TN.
- Hannerz, K., 1988. Making Progress on PIUS Design and Verification. *Nucl. Eng. Int.* **33**(412), 29-31.
- Int. At. Energy Agency, 1988. *Status of Advanced Technology and Design for Water-Cooled Reactors: Light-Water Reactors*. IAEA-TECDOC-479. Vienna, Austria.
- Int. At. Energy Agency, 1989. *Status of Advanced Technology and Design for Water-Cooled Reactors: Heavy Water Reactors*. IAEA-TECDOC-510. Vienna, Austria.
- Kataoka, Y., Suzuki, H., Murase, M., Sumida, I., Horiuchi, T., and Miki, M., 1988. Conceptual Design and Thermalhydraulic Characteristics of Natural Circulation Boiling-Water Reactors. *Nucl. Technol.* **82**(2):147-56.
- Lanning, D. D., 1989. Modularized High-Temperature Gas-Cooled Reactor Systems, *Nucl. Technol.* **88**(2):139-56.
- Lineberry, M. J., Pederson, D. R., Walters, L. C., and Cahalan, J. E. 1991. "Advances by the Integral Fast Reactor Program," *53rd Am. Power Conf., Chicago*.
- Matsuoka, T., 1991. "A Simplified Japanese PWR," *Nucl. Eng. Int.*, **36**(443).
- McCandless, R. J., and Redding, J. R., 1989. Simplicity: The Key to Improved Safety, Performance and Economics. *Nucl. Eng. Int.* **34**(424):20-24.
- Planchon, H. P., Sackett, J. I., Golden, G. H., and Sevy, R. H. 1987. "Implications of the EBR-II Inherent Safety Demonstration Test," *Nucl. Eng. Des.* **101**(1):75-90.

- Sako, K., 1988. "Conceptual Design of SPWR," *Am. Nucl. Soc. Top. Meet. on Safety of Next Generation Power Reactors*, Seattle, Washington.
- Staudt, J. E., and Lidsky, L. M., 1987. *Design Study of an MGR Direct Brayton Cycle Power Plant*, MITNPI-TR-018, Cambridge, Mass: MIT.
- Turinsky, P., Baron, S., Burch, W. D., Corradini, M., Lucas, G., Matthews, R. B., and Uhrig, R. E. 1991. *Western European Nuclear Power Generation*, Foreign Applied Sciences Assessment Center (FASAC), Science Applications International Corp. (In Press).
- Teare, K. R., 1989. SIR—An Imaginative Way Ahead. *Nucl. Eng. Int.* 34(419):32-34.
- Varley, B., 1989. Interest Grows in the Modular HTGR. *Nucl. Eng. Int.* 34(424):25-28.
- Vijuk, R., and Bruschi, H., 1988. AP600 Offers a Simpler Way to Greater Safety, Operability, and Maintainability, *Nucl. Eng. Int.* 33(412):22-28.
- Wakabayashi, H. 1985. "Small, Intrinsically Safe Reactor Implications," *On the New Concepts of Light-Water Reactors*, University of Tokyo, UTNL-Memo-0008.
- Wilkins, D. R., Seko, T., Sugino, S., and Hashimoto, H., 1986. Advanced BWR: Design Improvements Build on Proven Technology. *Nucl. Eng. Int.* 31(383):36-45.
- Wolfe, B., and Wilkins, D. R. 1989. "Future Directions in Boiling-Water Reactor Design," *Nucl. Eng. Des.* 115, 281-88.

APPENDIX B: PRIME SAFETY

The concerns with nuclear power have resulted in development of a set of design goals which, if achieved, would reduce safety as a public acceptance, environmental, or economic issue. Such design goals are independent of the technology. The development of these concepts parallels similar developments in the chemical industry to develop passive and inherently safe chemical plants.

Five characteristics for safety have been identified as necessary to eliminate major accidents. These characteristics have been described in various ways. These are Passive safety systems, Resilient safety, Inherent safety characteristics, Malevolence resistance, and Extended safety. The term "PRIME safety" is sometimes used to summarize these characteristics. An understanding of PRIME provides a good grasp of this revolution in safety philosophy. Some of these terms have been defined by an International Atomic Energy Agency consultants group [IAEA, 1990]. Safety terms which have been defined or described are in Table B.1.

PRIME safety implies using only passive safety systems and inherent safety characteristics in industrial plants versus the active safety systems used in today's plants. Examples from fire protection can help explain these terms. A concrete warehouse full of pottery is inherently safety against fire. In other words, a fire cannot occur. Inherent safety implies no need for safety systems. An example of passive safety is water sprinklers. Active safety, then, would be the fire department. Nuclear reactors cannot be made inherently safe because they contain hazardous radioactive materials, but reactors can be made inherently safe against specific types of accidents. U.S. power reactors are inherently safe against the type of accident that occurred at Chernobyl [Martinez-Val et al., 1990]. While active safety works most of the time, plant operators (like fire departments) can make errors. Operator error was a major cause of the accidents at both TMI and Chernobyl.

Elaborate and expensive safety systems can be built; however, if they are not maintained, they may fail. Because safety systems sometimes complicate operations and accidents are rare events, there is often the incentive for an operator to bypass safety systems. To prevent this problem, safety systems must be resilient. The historical example of resilient safety is the railroad air brake—an active safety system that is very resilient. Railroad air brakes are designed to be on. To hold the brakes in the off position, the locomotive engineer must continuously supply high-pressure air to each railcar brake system. If either a brake line or the air pressure should fail, the brakes are immediately activated. In order for the train to function, the brake system—a resilient safety system—must work properly. In resilient systems, maintenance to ensure operation also ensures safety.

The fourth requirement for safety is malevolence resistance. Malevolence resistance protects against sabotage, terrorists, and off-the-shelf conventional military munitions. It is thought, by many, that the Bophal chemical disaster was initiated by employee sabotage. In industries with high levels of safety, such as the aircraft, nuclear, and chemical industries, sabotage may become a major accident initiator because other accident initiators have been eliminated. The "dark side" of human nature may necessitate development of safety approaches that are not dependent on security forces. Malevolence resistance also provides protection against all types of operator error such as that which occurred at TMI or through shutdown of safety

Table B.1. International Atomic Energy Agency draft description of terms

1. Inherent safety characteristics
Safety achieved by the elimination of a specified hazard by means of the choice of material and design concept.
2. Passive component
A component which does not need any external input to operate.
3. Active component
Any component that is not passive is active.
4. Passive system
Either a system which is composed entirely of passive components and structures or a system which uses active components in a very limited way to initiate subsequent passive operation.
5. Active system
Any system that is not passive is active.
6. Fail-safe
The term describes the behavior of a component or system, following a failure (either internal or external). If a given failure leads directly to a safe condition, the component or system is fail-safe with respect to that failure.
7. Grace period
The grace period is the period of time during which a safety function is ensured without the necessity of personnel action in the event of an incident/accident.
8. Foolproof
Safe against human error or misguided human action.
9. Fault-/error-tolerant (also called forgiving)
The term fault-/error-tolerant, also called forgiving, describes the degree to which equipment faults/human inaction (or erroneous action) can be tolerated.

Table B.1. International Atomic Energy Agency draft description of terms
(continued)

10. Simplified safety system

A system designed with a minimum number of components to achieve the related safety function and relying as little as possible on support systems.

11. Transparent safety

Safety which is obvious or easily understandable; this normally follows from simple, straightforward design concepts or from inherent safety characteristics.

systems to improve plant availability—a problem in some parts of the world [Hibbs, 1990]. Active safety systems (valves, computers, operators), which can be turned off, are sensitive to sabotage; therefore, malevolence resistance as a precondition requires both passive and inherent safety.

Finally, extended safety is required; that is, the plant must stay in a safe state for some defined period after an accident, sabotage, or attack without releasing hazardous materials. This allows time for emergency officials to respond to any accident and ensure no eventual release of radionuclides to the environment. Typically, a period of 1 week is chosen to provide time for corrective actions.

B.1 REFERENCES

Hibbs, M. June 1990. "GDK Orders Greifswald Shut: GRS Hits Operational Safety," *Nucleonics Week* 31(23), 2.

International Atomic Energy Agency Consultants Group, 1990. "Description of Safety-Related Terms for Advanced Nuclear Plants," 622-I3-TC-633, Vienna, Austria.

Martinez-Val, J. M., Aragoes, J. M., Minguez, E., Perlado, J. M., and Velarde, G. 1990. "An Analysis of the Physical Causes of the Chernobyl Accident," *Nucl. Technol.* 90, 371.

APPENDIX C: TECHNICAL DESCRIPTIONS OF REACTOR AND CONTAINMENT CONCEPTS

C.1 INTRODUCTION

This appendix provides brief technical descriptions of the two most developed mainline reactor concepts with PRIME (passive safety, resilient safety, inherent safety, malevolence resistance, and extended time for external assistance) safety goals—Process Inherent Ultimate Safety (PIUS) and modular high-temperature gas-cooled reactors (MHTGR). In each case, various derivative concepts have been developed. Also described are the supercontainment systems.

C.2 PIUS REACTOR

The PIUS reactor, which was invented by K. Hannerz of ABB, is also referred to as Secure P[®] in the literature [Bredolt, 1988; Hannerz, 1983; Hannerz, 1985a; Hannerz et al., 1990; IAEA, 1988].

The PIUS reactor is a modified "swimming pool" pressurized-water reactor (PWR); the pool is at full reactor pressure and contains high concentrations of cool, borated water. The reactor normally operates in a second volume of hot, low-boron reactor water within the pool. In the event of an accident, the cool, borated (neutron poisoned) water enters the reactor core. The boron in the water shuts down the reactor and the reactor core is cooled by boiloff of the borated water. The period during which this Emergency Core Cooling System (ECCS) works in a passive mode depends on the volume of borated water available to be boiled off. Current proposed designs provide 1 week of passive heat removal.

This reactor has two unique features: (1) a very large pressure vessel that includes the reactor core and all key safety systems, and (2) the safety system that puts cool, borated water in direct contact with the hot, low-boron reactor coolant water. The cool, borated water does not enter the reactor core during normal operations because of a hydraulic balance maintained by the main recirculation pumps. In an accident, the reactor core is flooded with this water.

The pressure vessel is a prestressed-concrete reactor vessel (PCRV). Key characteristics include the following:

1. The PCRV contains sufficient borated water to cool the reactor core for 1 week after reactor shutdown. To accomplish this goal, the internal vessel diameter is 12 to 13 m.
2. The PCRV is large enough to allow spent fuel storage in the vessel for the reactor lifetime.
3. The PCRV provides very high levels of protection against external threats. The wall thickness is ~7 m.

The PCRV has several unique design features:

1. It contains both steel reinforcing bars and prestressed steel tendons. The redundant design allows for failure of either reinforcing bars or tendons without catastrophic vessel failure.
2. It contains a double internal steel liner to prevent leakage of water. From the inside to the outside, the vessel includes an inner liner, 1-m-thick concrete, a secondary liner, and the main PCRV.

The second unique feature of the PIUS PWR is the hydraulic emergency core cooling system. The operating principles of this system are shown in Fig. C.1.

Figure C.1(A) shows a natural-circulation PWR reactor core (C) inside a very large pressure vessel (A). The reactor core is in a zone of low-boron water (D) at the bottom of the riser. The riser incorporates a pressurizer (I) to maintain reactor vessel pressure at desired levels. The pressure vessel is primarily filled with cool, borated water (B). The low boron concentration of the water allows the reactor to be critical and produce heat. In this configuration, the reactor would be shut down quickly by the natural circulation of borated water into the core from below (J) and out through the top of the riser (K).

In Fig. C.1(B), the hot reactor water is returned from point M near the top of the riser to a point N below the core by addition of a recirculation pump (E).

In Fig. C.1 (C), a steam generator (F) has been added to the circulating water flow to keep the temperature constant. The steam generator and pump can be located either inside or outside the pressure vessel. The reactor is a natural-circulation reactor dependent on differences in water densities of the high-temperature, low-boron-concentration water in the riser and the low-temperature, high-boron-concentration water in the pool. The pump simply overcomes pressure drops in the steam generator and associated piping between points M and N. It pulls the full flow of hot water from the reactor point M and delivers it to point N.

There are two flow paths of the water from above the reactor core (point M) to back below the reactor core (point N). The first is through the steam generator and pump (M,F,E,N). The second is through the cold, borated water zone (M,K,B,J,N). If the cool, highly borated water flows into the core, the reactor will be shut down. This does not happen in operation because of a careful hydraulic balance generated by the pump.

If the rate of the recirculation pump slows to less than that of the natural water circulation [Fig. C.1(D)] through the core, then cold, borated water will enter the core from point J and shut the reactor down. If the pump operates too rapidly, pump suction will draw cold, borated water into the system near point M and through the steam generator and pump [Fig. C.1(E)]. The pump discharge will push some highly borated water into the core near point N and the remaining water into the cold, borated water zone below point N. In effect, the hot, low-borated water zone that allows the reactor to produce power is stable against the ingress of cold, borated water at only one pump speed for each set of operating conditions.

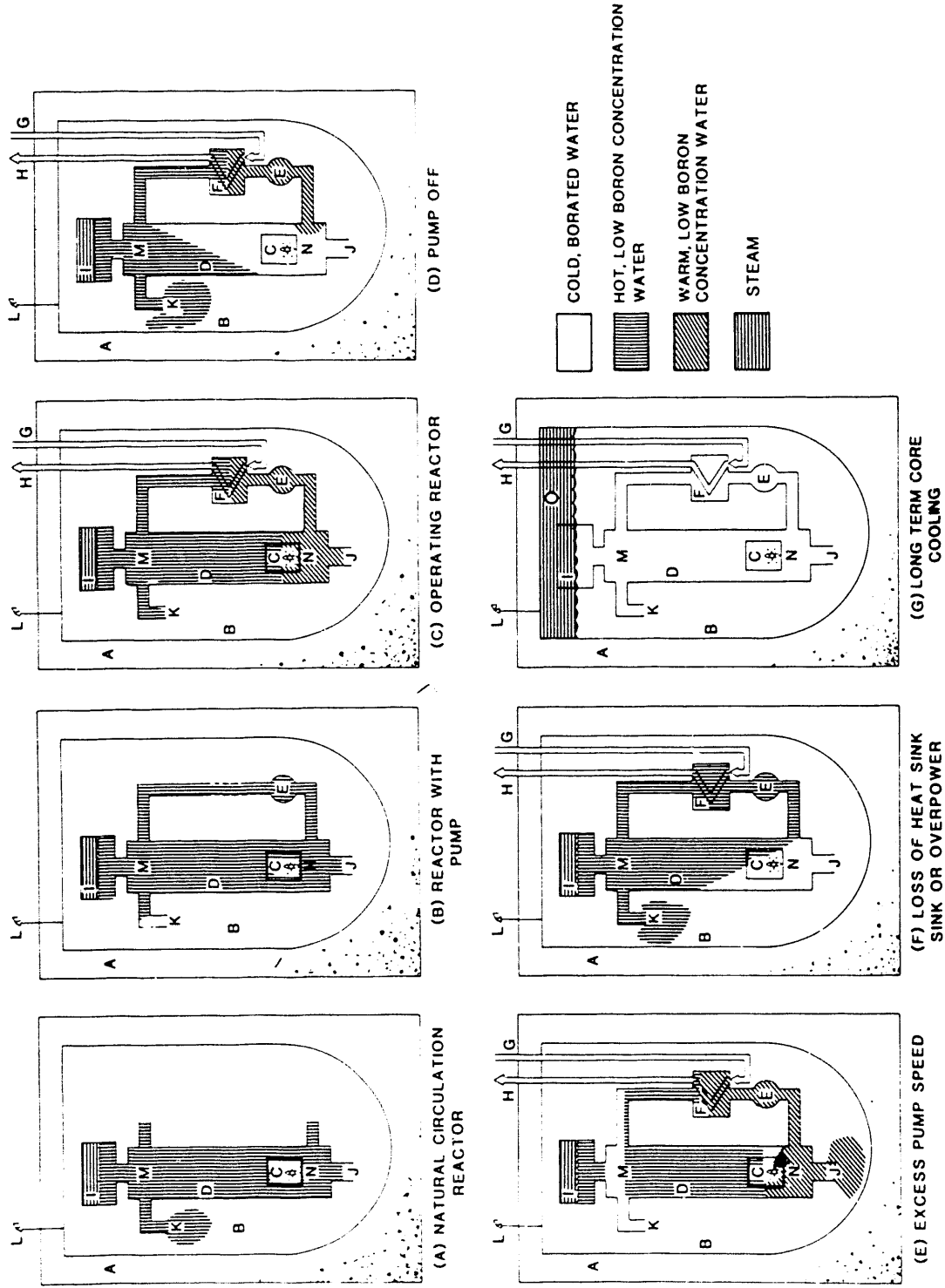

Fig. C.1. Operating principles of PIUS.

The hot reactor water is separated from the cold, borated water by interface zones (J,K). The large density differences between the two water zones make the interface very stable. Instruments sense whether the hot/cold interface zone is moving up or down and will adjust the pump speed accordingly.

Power levels in the core are controlled by varying the boron concentrations in the hot reactor water. The hydraulic balancing also protects against reactor overpower conditions or loss of feedwater to the steam generators. In either case, boiling will eventually occur in the reactor core [Fig. C.1(F)]. Boiling causes major increases in natural circulation flows through the core. The recirculation pump is sized so that it physically cannot handle the water flow through the reactor core under these circumstances. Thus, the hydraulic balance breaks down, and cold, borated water enters the core from the bottom.

After the reactor shutdown, the cool, borated water heats up, absorbing radioactive decay heat. Eventually, the borated water boils, and steam is released through pressure relief valves. The reactor will be cooled as long as water remains in the pressure vessel [Fig. C.1(G)].

A recent design of the PIUS reactor by Asea Brown-Boveri (ABB) is shown in Fig. C.2; some design parameters are given in Table C.1. PIUS reactor design options include steam generators on either the inside or the outside of the PCRV. Siphon breakers prevent siphoning of water from the PCRV if there is a pipe break. This design is for a 640-MW(e), 2000-MW(t) power reactor. The current design also includes four independent natural circulation cooling systems that transfer heat from the cool, borated water to the air during normal and emergency operations. During normal operations, heat leaks from hot water through the walls to the cold, borated water zone. During emergency operations, these cooling systems will remove all core decay heat from the high-boron-concentration water zone as water circulates between the two zones. The reactor core is protected essentially forever if the natural-circulation air coolers are operating, or for at least 1 week in the event of air cooler failure. The air coolers can withstand normal expected events (storms, earthquakes, etc.) but, because they require good access to air, cannot be protected against some types of sabotage or external military assault.

C.3 MODULAR HIGH-TEMPERATURE GAS-COOLED REACTOR

Both HTR GmbH in West Germany and General Atomics in the United States have proposed steam cycle MHTGRs. General Atomics is examining a range of designs from 350 to 450 MW(t) per reactor. The corresponding electric power outputs vary from 135 to 173 MW(e) per reactor. A typical plant would consist of four reactors with some equipment in common. The size of the reactor is the maximum for which decay heat from the reactor can be conducted out of the walls of the reactor to the soil while maintaining central reactor core below temperatures at which fuel failure occurs. In principle, this type of decay heat cooling can be used for any reactor; however, for most reactor types, the reactor size is so small as to make it uneconomical. The MHTGR can be built to a reasonably large size because the fuel temperatures can exceed 1600°C for very long times before fuel failure. With such high-temperature capabilities, reasonably sized reactors can be built.

ORNL DWG. 88-1004

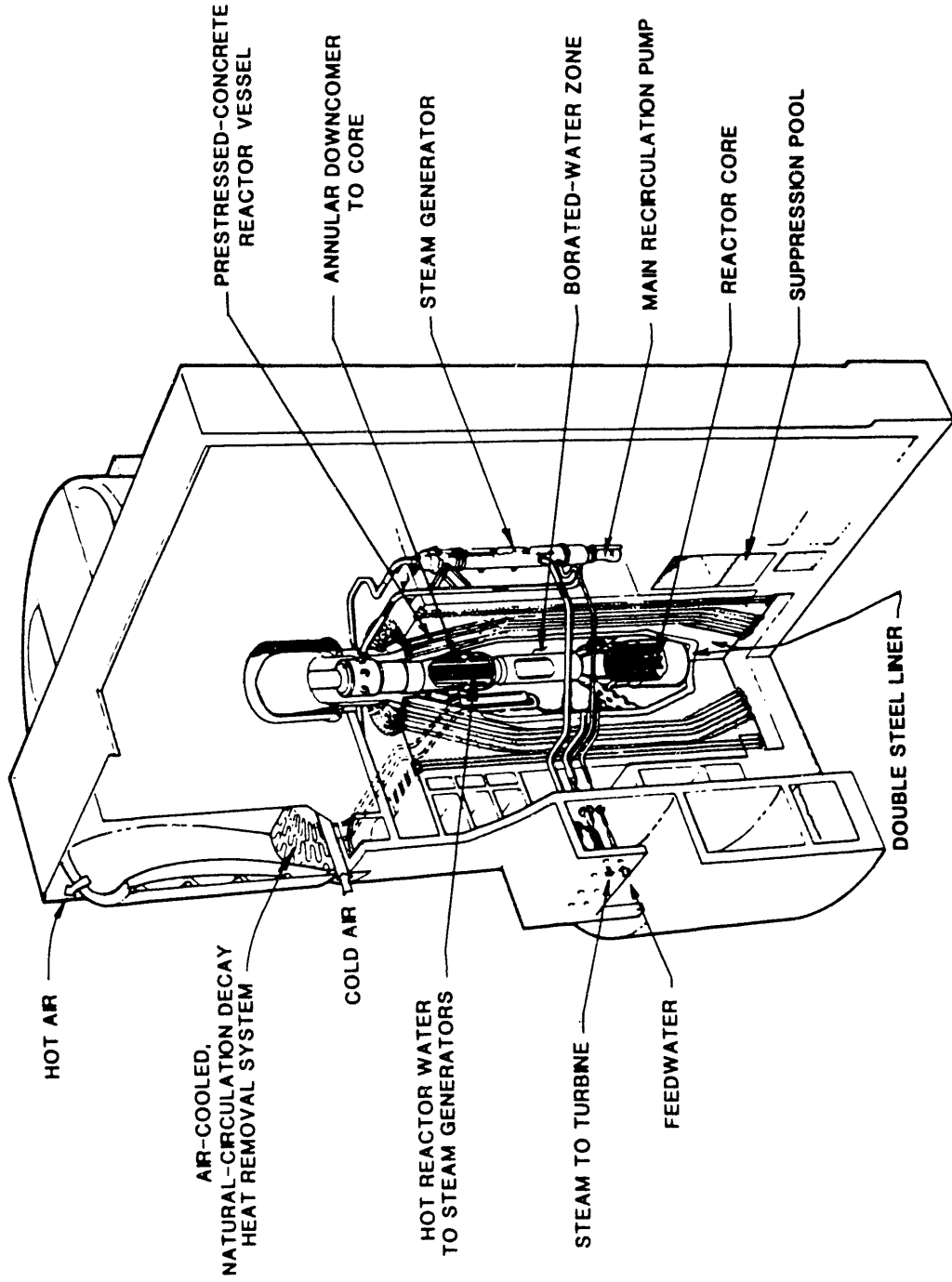

Fig. C.2. Proposed PIUS design by ABB Atom.

Table C.1. Some key design data for the PIUS (Secure-P) Reactor

| | | |
|--|----------------|------------------|
| Thermal power | MW(t) | 2000 |
| Electric power (net) | MW(e) | 640 |
| Core exit temperature (full power) | °C | 290 |
| Core inlet temperature (full power) | °C | 260 |
| Core coolant flow | kg/s | 13,000 |
| Primary system pressure (pressurizer) | MPa | 9.0 |
| Number of fuel assemblies | | 213 |
| Number of fuel rods/assembly | | 316 ^a |
| Fuel enrichment, reload fuel | % | 3.5 |
| Average burnup | MWd/ton | 45,500 |
| Core height (active) | m | 2.50 |
| Core diameter (equivalent) | m | 3.75 |
| Core pressure drop (dynamic) | MPa | 0.039 |
| Number of steam generators | | 4 |
| Steam pressure (steam generator exit) | MPa | 4.0 |
| Steam temperature | °C | 270 |
| Number of reactor coolant pumps | | 4 |
| Pool temperature (normal operation) | °C | 50 |
| Concrete vessel internal cavity diameter | m | 12.2 |
| Concrete vessel cavity internal height | m | 36 |
| Concrete vessel cavity total height | m | 43 |
| Concrete vessel cavity volume | m ³ | 3300 |
| Concrete vessel thickness (minimum) | m | 7 |

^aUp to 32 fuel rods containing burnable absorber (Gd₂O₃).

Figure C.3 shows a cross section of a representative United States design for a steam cycle MHTGR. Figure C.4 shows a typical power cycle for the gas turbine MHTGR version, which is considered an advanced option. Table C.2 shows key design parameters [NEA, 1991] for the 450 MW(t) steam cycle design. This design includes air cooling of the pressure vessel. Air cooling protects the reactor vessel against damage in an accident (investment protection) but is not required for safety.

One advantage of the small size of the modular design is that a unit could be shop-fabricated and shipped to the site. Shop fabrication should lead to major reductions in cost and construction time as well as yield a higher-quality product. These advantages of the modular design from the cost and construction standpoints may be offset by the increase in the amount of instrumentation and control equipment needed, because each of the modular units would require a full set of such equipment, and some additional equipment would be needed to operate a multiplicity of units in parallel.

In view of the fail-safe nature of the modular plant, the German licensing authorities have ruled that the associated balance-of-plant equipment can be commercial grade as opposed to reactor grade. This approach to licensing should improve the overall economics.

The major advance in MHTGR technology in the last 5 years was the experimental demonstration at the AVR (an MHTGR test reactor in West Germany) that an MHTGR can withstand loss-of-coolant flow and loss of coolant without damage to the reactor core [Krüger and Cleveland, 1989]. Furthermore, calculations indicate the ability of MHTGRs to withstand severe reactivity accidents. Like most reactors, MHTGRs have a negative temperature coefficient. In most reactors other than the MHTGR, removal of all control rods would result in excessive power and temperature with destruction of the reactor core. For MHTGRs, the very high-temperature capabilities of the core and the negative temperature coefficient make it possible to ensure reactor shutdown via the negative temperature coefficient before serious reactor core damage occurs; in effect, control rods are an operating system, not a safety system.

C.4 SUPERCONTAINMENTS

The second direction of nuclear power development with the goal of wide public acceptance is supercontainments. A containment system is a box designed so that no radioactivity escapes to the environment if there is a reactor accident. The experience of Three Mile Island (TMI), in which there was a partial reactor core meltdown but almost no release of radioactivity, demonstrated some of the potential of containments.

Supercontainment developments are proceeding in two directions: (1) better "boxes" and (2) methods to limit radioactive releases from core materials during core melt accidents.

C.4.1 Containment Structure

In Germany at Kernforschungszentrum Karlsruhe [Hennies, Kessler, and Eibl, 1989; Häfele, 1990; Eibl, 1990] and elsewhere in Europe, there are substantial research programs

ORNL-DWG-88-7892

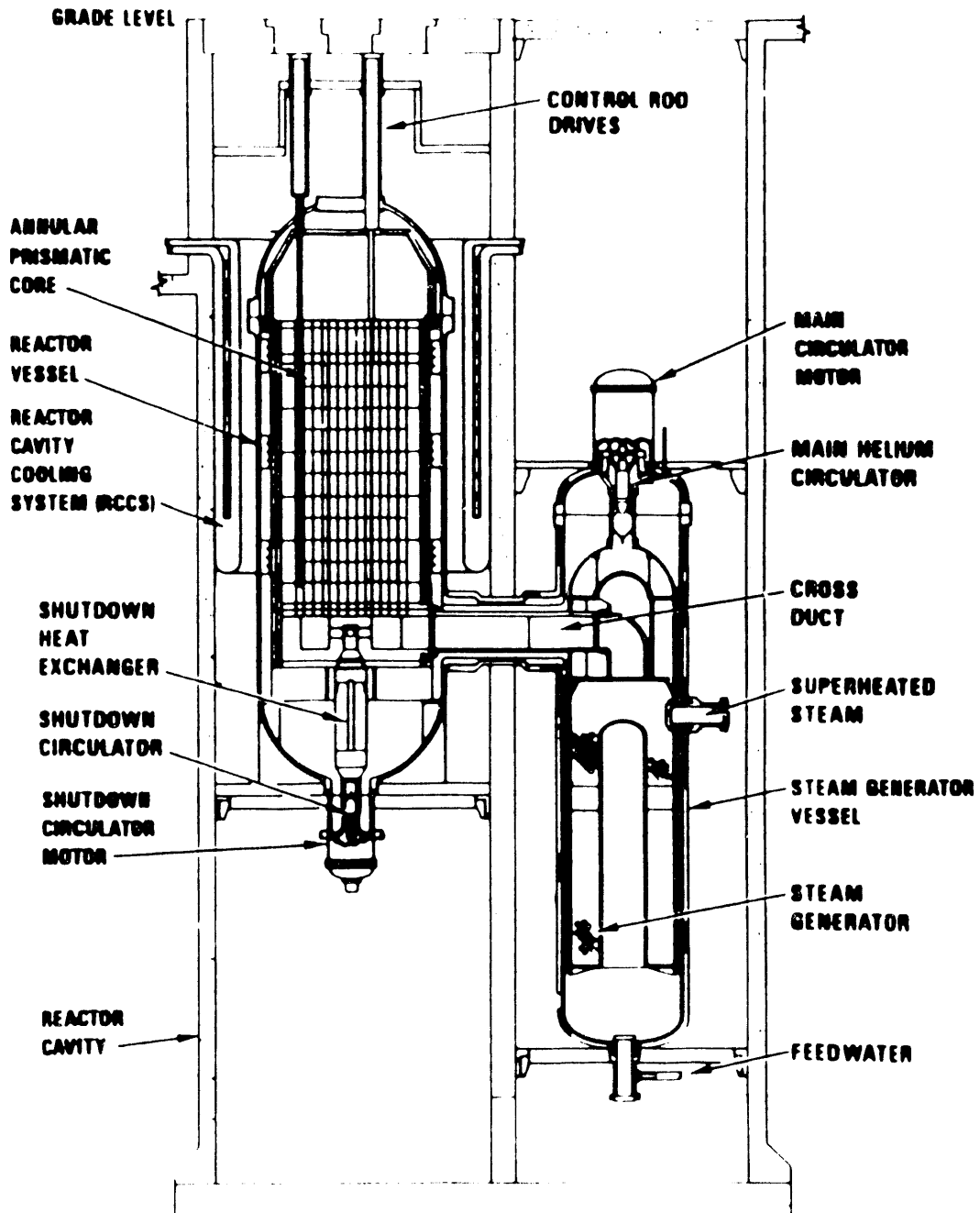

Fig. C.3. Modular 350 MW(t) High-Temperature Gas-Cooled Reactor.

ORNL DWG 91A-542

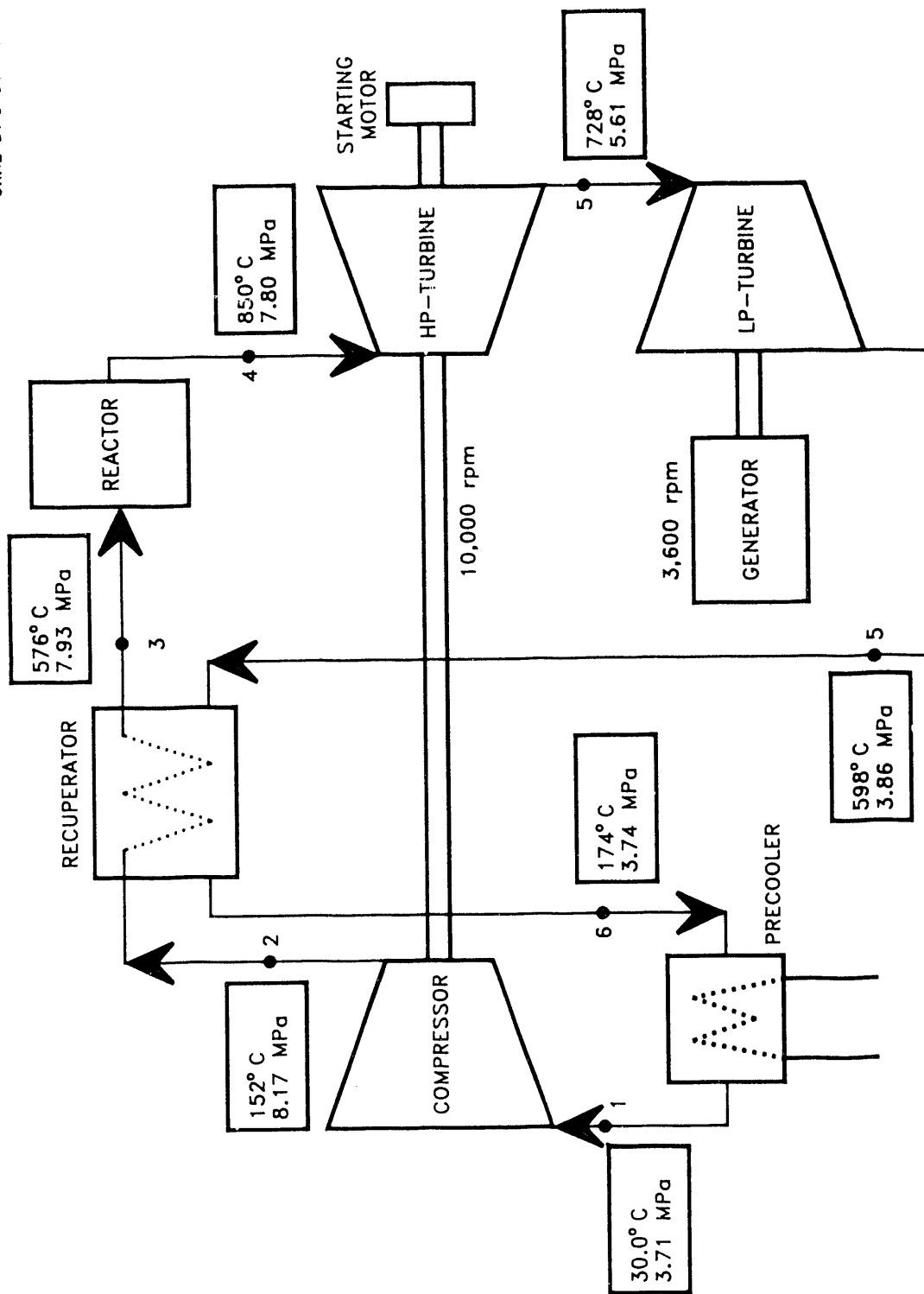

Fig. C.4. MHTGR-GT power cycle process.

Table C.2. United States MHTGR major plant parameters for the 450 Mw(t) design

| | | |
|--------------------------------|-------------------|-------------------|
| Plant | | |
| Configuration | Reactor modules | 4 |
| Thermal power | MW(t) | 1800 (4 x 450) |
| Net electric power | MW(e) | 692 |
| Helium pressure | psia | 1025 |
| Helium temperature, in | °F | 550 |
| Helium temperature, out | °F | 1300 |
| Reactor core | | |
| Fuel element type | | Prismatic |
| Power density | W/cm ³ | 5.99 |
| Enrichment | % | 19.9 |
| Fertile Material | | UO ₂ |
| Reactor vessel (1 of 4) | | |
| Outside diameter | ft | 27.25 |
| Outside height | ft | 72.0 |

to develop supercontainments designed to withstand any potential internal reactor accident including pressure-vessel failure, largest possible hydrogen explosion, steam explosions, and various core melt accidents. The distinction between conventional containments and these designs is that conventional containments are designed to withstand those accidents that are considered most probable. Supercontainment designs account for all accidents without consideration of probabilities. Current cost estimates suggest that such containments would increase total plant costs by <5% compared with modern German containments. At the present time, the German containments may be the best built containments in the world. Figure C.5 shows an example containment design.

C.4.2 Reduced-Accident Source Term

A variety of systems are being proposed to limit generation of radioactive gases and aerosols in containment in the event of a core melt accident, but few details have been published. These systems include:

1. Nonzirconium fuel assemblies to eliminate generation of hydrogen in an accident by reaction of zirconium and water (TMI problem),
2. Cesium atmospheric absorption systems, and
3. Core-melt source reduction systems (COMSORS).

An example of one of these systems, COMSORS, is described below. COMSORS refers to a set of concepts to limit maximum release of aerosols and gases to containment from a reactor core melt accident. If a reactor core meltdown occurs, the molten core material will eventually contact and begin to melt the concrete foundation structure. The chemical reactions and molten core/concrete temperatures will determine the rate and quantities of radioactive gases and aerosols generated by the core/concrete interactions and released to containment. The generation of gases can pressurize the containment and increase the potential for containment failure. If containment fails, the quantities of radioactive aerosols and gases determine the maximum accident potential. If the containment does not fail, large quantities of radioactive aerosols and gases in containment will not only slow efforts to stop an accident but will also slow cleanup after an accident. Use of COMSORS, either as a separate engineered device or by selection of appropriate aggregate in the concrete, may allow the creation of a method to limit the maximum possible source term (radioactive gases and aerosols) by incorporation of molten core and other materials into a stable high-level waste (HLW) matrix. This concept is based on two sets of experimental observations.

1. The U.S. NRC, its contractors, and others [Nourbakhsh, Khatib-Rahbar, and Davis, 1988; Powers, 1979; Skokan and Holleck, 1979; Peehs, Skokan, and Reimann, 1979] have been investigating the physical and chemical mechanisms of a reactor core meltdown. This has included experiments in which molten core materials have been poured onto various types of concrete used in nuclear power plants under the reactor core. The experimental studies show that the quantities of radioactive gases and aerosols generated and released by the molten core/concrete interactions vary widely depending on concrete chemistry (see Fig. C.6). For example, concrete containing

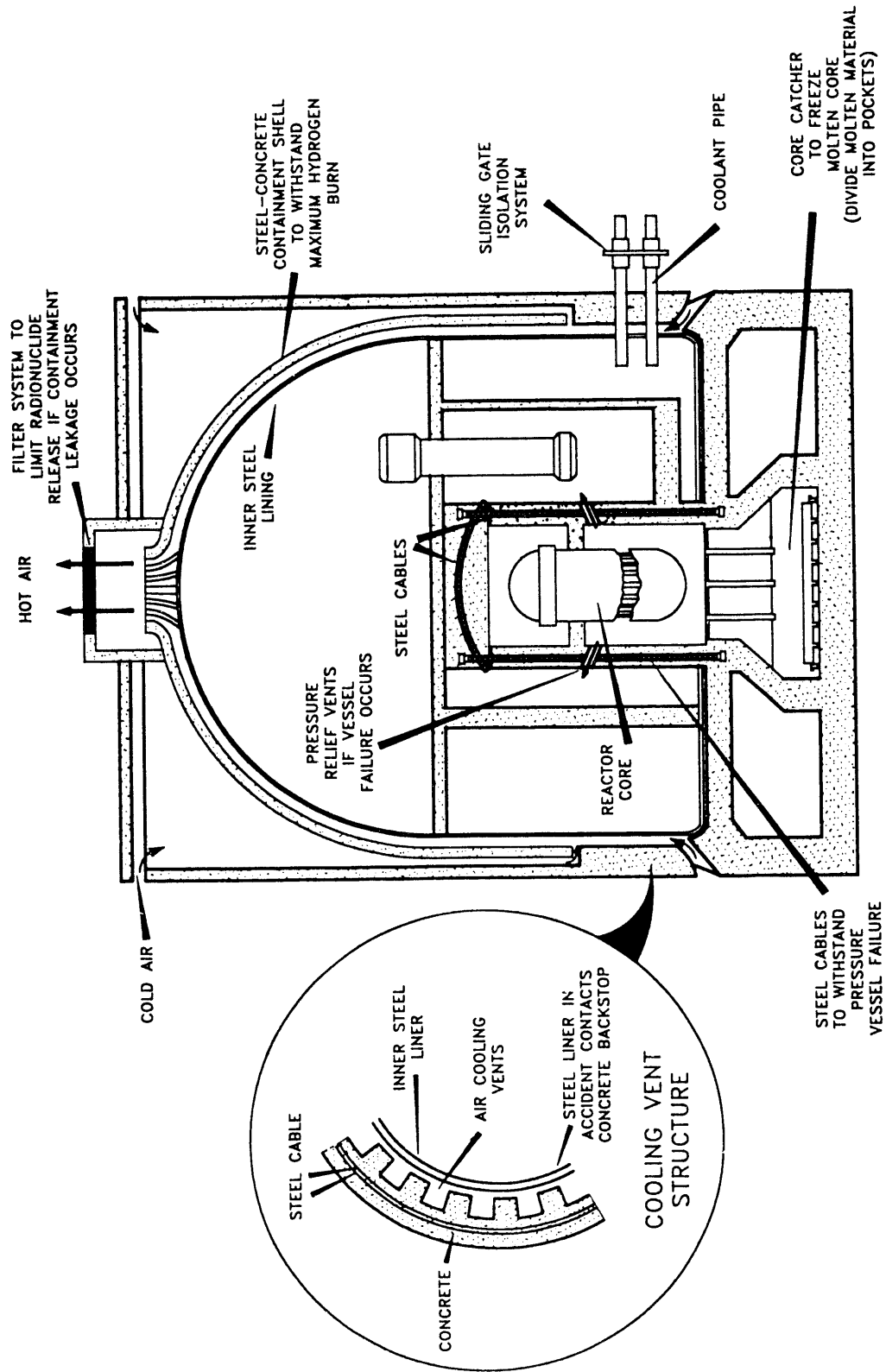
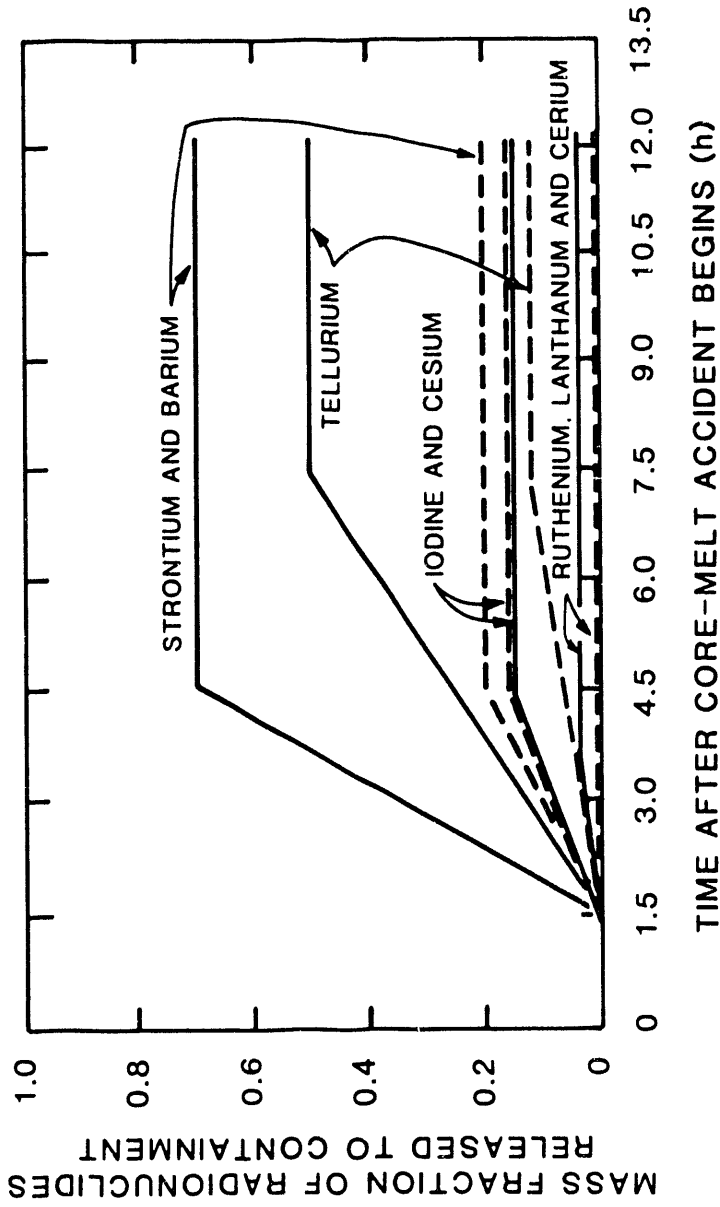

Fig. C.5. Example of German advanced containment structure.



VARIABLES
 - - - - BASALTIC CONCRETE/CORE INTERACTIONS
 ——— LIMESTONE CONCRETE/CORE INTERACTIONS
 CASE SPECIFICS
 BOILING WATER REACTOR
 HIGH REACTOR COOLANT SYSTEM PRESSURE BEFORE STEEL VESSEL MELTTHROUGH
 DRY CAVITY

Fig. C.6. Cumulative release fractions of radionuclides to containment by chemical group and concrete type after core-melt accident.

limestone aggregate causes high rates of radioactive gas and aerosol generation because the limestone decomposes at high temperatures and releases carbon dioxide gases. The gas generation creates aerosols and strips the more volatile fission products from the concrete/core molten bath. In contrast, concrete containing basaltic (volcanic) and granite aggregates does not generate large quantities of gases and, hence, releases less radioactivity to the containment atmosphere when reacting with core melt materials.

2. There are major programs in the United States, Europe, and Japan for the solidification of HLW from reprocessing plants into stable, low-leach glasses. There are multiple requirements to solidify HLW [Ramsey and Wicks, 1988]. The glass must incorporate uranium, plutonium, and fission products into a stable chemical form and must allow easy processability and minimize generation of radioactive aerosols and gaseous fission products. Excessive aerosol or gas generation during solidification processes would result in operating difficulties and high costs for treating HLW plant off-gas streams. In principle, the requirements to make HLW glass from reprocessing plant HLW and the requirements to stop and solidify materials from a molten reactor core meltdown are similar.

A conceptual description of an advanced COMSORS incorporated into the concrete structure is described herein. Under the reactor vessel (Fig. C.7), a portion of the concrete mat has a specially controlled concrete mat chemical composition. The concrete contains a mixture of different aggregates. The aggregates are chosen so that when the various aggregates—cement, steel rebar, and core materials—melt, a waste glass that incorporates the core materials is created. The glass contains one or more aggregates containing neutron poisons to prevent any possibility of a criticality accident. The glass chemical composition is chosen to have a very high affinity for volatile fission products. The aggregates are chosen to minimize gas generation upon melting and, hence, minimize aerosol formation. The glass also has a high surface tension to minimize aerosol generation.

The depth and width of the concrete mat with the special concrete aggregate is chosen to contain the reactor core. A heat balance exists between radioactive decay heat and (1) heat needed to melt the concrete, and (2) heat conducted out or removed by other mechanisms from the molten core/concrete matrix. Eventually, heat conduction out of the waste matrix will exceed heat generation and the molten core/concrete matrix will begin to solidify. The special aggregate concrete mat is sized to exceed the maximum volume of the molten core/concrete matrix, and the area is chosen to maximize cooling. In particular, the top surface area is large enough to radiate sufficient decay heat so that it will cool and solidify the waste matrix over time, without meltthrough of the reactor basemat.

The concrete aggregate is a relatively low-melting aggregate (400 to 900°C). Low melting points are desirable for the following reasons:

1. A low melting waste matrix will quickly spread the molten core/concrete material over a wide area under the reactor. This improves heat transfer and cools the matrix to quickly form a solid.

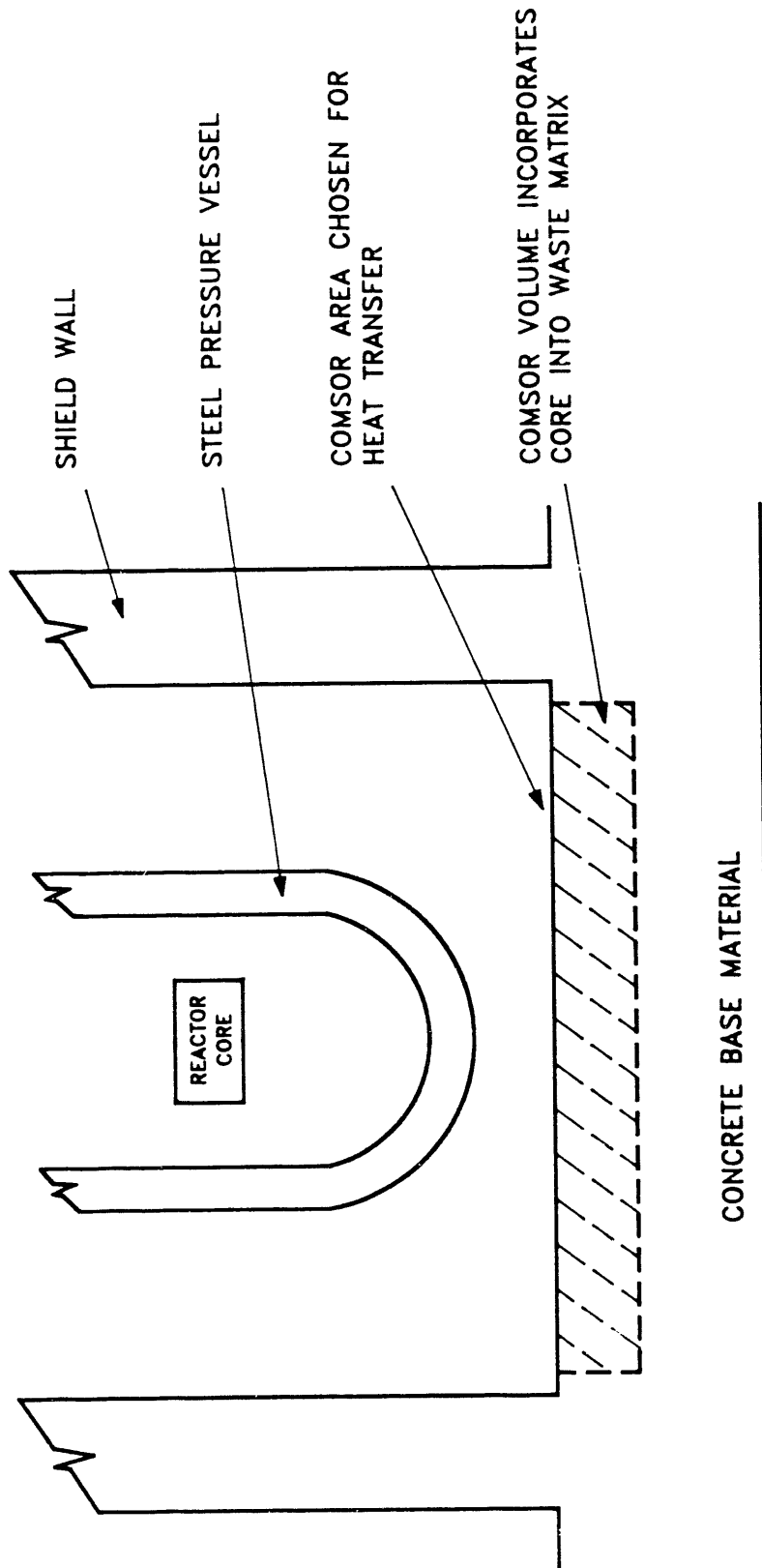

Fig. C.7. Core Melt Source Reduction System (COMSORS).

2. A low melting waste matrix minimizes gas and aerosol generation by two mechanisms. First, the rate of release of semivolatile radioactive gases is temperature dependent. Lower temperatures imply less gas release. Second, the rate of release of semivolatile radioactive gases is dependent on the concentration of those materials in the waste matrix. Diluting the core material reduces the fractional releases of radioactive materials.

For a number of advanced LWRs [Fogelstrom and Simon, 1988], the use of core catchers is planned. For example, the Asea Brown Boveri-Atom (a 1000 MW(e) boiling-water reactor), Model BWR-90, incorporates a core catcher into the design.

C.5 REFERENCES

- Bredolt, U. May 1988. "PIUS — the Next Generation Water Reactor," American Nuclear Society Conference: Safety of Next Generation Power Reactors, Seattle, Washington.
- Eibl, J., 1990. *Zur bautechnisch en Machbarkeit eines alternativen Containments für Druckwasserreaktoren*, Kernforschungszentrum Karlsruhe (KfK).
- Fogelstrom, L. and Simon, M., 1988. "Development Trends in the Area of Light-Water Reactors," *Atomwirtschaft*, p.423 (Aug./Sept. 1988): ORNL/TR-88/38.
- Häfele, W., 1990. "Energy From Nuclear Power," *Scientific American* (Aug. 1990).
- Hannerz, K., 1983. *Towards Intrinsically Safe Light-Water Reactors*, ORAU/IEA-83-2(M)-Rev, Oak Ridge Associated Universities.
- Hannerz, K. 1985a. *Nuclear Reactor Plant*, U.S. Patent 4,526,742.
- Hannerz, K. and Babala, D. 1990. "Pressurized Water Reactor Inherent Core Protection by Prime System Thermohydraulics," *Nucl. Sci. Eng.* 91(1), 81.
- Hannerz, K., Nilsson, L., Pederson, T., and Pind, C., 1990. "The PIUS Pressurized Reactor: Aspects of Plant Operations and Availability," *Nucl. Tech.* 91 (1),81.
- Hennies, H. H., Kessler, G., Eibl, J., 1989. "Improved Containment Concept for Future PWR," *Int. Workshop on Safety of Nuclear Installations of the Next Generation and Beyond*, Chicago, IL, USA.
- International Atomic Energy Agency, April 1988. *Status of Advanced Technology and Design for Water-Cooled Reactors: Light-Water Report*, IAEA-TECDOC-479.
- Krüger, K. and Cleveland, J. 1989. "Loss-of-Coolant Accident Experiment at the AVR Gas-Cooled Reactor," *Trans. Am. Nucl. Soc.* 60, 735-36.
- Nourbakhsh, H. P., Khatib-Rahbar, M., Davis, R. E., 1988. *Fission Product Release Characteristics Into Containment Under Design Basis and Severe Accident Conditions*, NUREG/CR-4881 (BNL-NUREG-52059).
- Nuclear Energy Agency, 1991. *Small and Medium Nuclear Reactors: What Prospects* (In Press). Peehs, M., Skokan, A., and Reimann, M., 1979. "The Behavior of Concrete in Contact with Molten Croium in the Case of a Hypothetical Core Melt Accident," *Nucl. Technol.*, 46, 192.
- Powers, D. A., 1979. "A Survey of Melt Interactions With Core Retention Materials," *Proceedings of the International Meeting on Fast Reactor Safety Technology*, Seattle, Washington.

Ramsey, W. G., and Wicks, G. G., 1988. *WIPP/SRL In Situ Tests-Part III: Compositional Correlations of MIIT Waste Glasses*, DP-1769.

Skokan, A., Pechs, M., and Holleck, H., 1979. "Chemical Reactions Between Light Water Reactor Core Melt and Concretes," *Nucl. Technol.*, 46 255.

APPENDIX D: EVOLUTIONARY TECHNOLOGY REACTORS

D.1 INTRODUCTION

D.1.1 General

Evolutionary technology water-cooled reactors are proposed advanced reactors that use the technology of current reactors but with significant changes in plant design, particularly the safety systems. These reactors contain passive safety systems and some safety systems that require power to initiate safety operations but are passive in operation after initiation.

Most of these reactors have electric power outputs of 300 to 600 MW(e), but may be scaled to much larger sizes [EPRI, 1991; Anon, 1990]. Studies of larger-size reactors have been reported for the MS-600, AP-600, and Simplified Boiling-Water Reactor (SBWR) reactors described herein. When developing new designs, it is less expensive to develop the technology for a midsize reactor first and then use that experience for engineering of larger plants. In the United States, there is the perspective that the utilities prefer midsize plants. In most of Europe and Japan, larger plants are considered preferable.

This appendix provides brief technical descriptions of the eight evolutionary technology reactor designs shown in Table A.1. The reactor designs are presented in alphabetical order by country of origin.

D.1.2 Technical Description

Most of these proposed reactors have the following common technical features [Forsberg and Weinberg, 1990]:

1. All water required for heat removal in the primary system drains by gravity to the reactor core, which is located at the lowest elevation in the plant. In the Three Mile Island (TMI) accident, the plant layout did not permit the water in part of the reactor system (the steam generators) to flow by gravity to the reactor core. Such water flow would have cooled the reactor core by boiloff and prevented damage to the reactor core.
2. Large AC power sources (diesel generators) to run emergency equipment have been eliminated. In current plants, emergency equipment consuming large amounts of electric power and associated power supplies have proven expensive to build, maintain, and operate. Furthermore, the complexity of the equipment increases the probability of operator error in an emergency. The elimination of emergency diesel generators has necessitated major changes in those emergency systems that consumed electric power—the emergency core cooling systems and the containment cooling systems. The evolutionary technology light-water reactors (LWRs) do require battery power in an emergency to initiate safety system operations (open valves, etc.).
3. For emergency core cooling in the event of a major pipe break or other accident, existing and proposed evolutionary plant nuclear power plants pump cooling water into the reactor core. This requires large pumps and, hence, diesel generators to provide

power. The proposed evolutionary technology LWRs use a different approach. In most of these designs, large volumes of water are stored above the reactor core. In an accident, the reactor is depressurized by opening valves and then water flows by gravity from overhead tanks into the reactor vessel. Typically, there is sufficient water to flood the reactor containment and reactor system above the level of any pipe failure in the primary system.

4. Passive systems are used to cool the reactor containment in the event of an accident. All the proposed evolutionary technology LWRs have larger quantities of cold water in containment, which can absorb heat after an accident. One or more of the following concepts is used to cool the containment passively: air-cooled steel containment, heat pipe or modified heat pipe, or boiloff of clean water outside of containment by transfer of containment heat through containment cooling walls.
5. Reactor power densities have been reduced. This both increases the margin of safety and widens the operating window for reactor operations, which reduces the sensitivity of the reactor to operator error.
6. Finally, a major effort has been made to simplify the design. The complexity of existing plants implies high cost and the possibility of operator/maintenance error. Plant simplification is possible because the designs are new and not just modifications of existing plant designs.

D.2 ARGENTINA

D.2.1 General Characteristics

The Argentinean (CAREM) project is focused on developing a very low-power pressurized-water reactor (PWR) with a rated capacity between 25 and 150 MW(e). The applications being considered include electric power generation, industrial steam production, water desalination, and urban heating.

The economies of scale achieved with larger power reactors are not realized with a very low-power design. In order to counter this limitation, a number of design objectives were adopted for the CAREM project to reduce costs, including: (1) modular reactor design with factory fabrication; (2) standardization of the design, manufacture, construction, and maintenance; (3) simple control systems with emphasis on self-regulation; and (4) emergency cooling systems with active initiation, but passive operation.

A typical reactor would contain one or more CAREM modules that share common services, such as a single control room, effluent treatment plant, and fuel storage pool. Each module would be preassembled and tested before shipment to the reactor site. This would decrease construction costs and schedules as well as limit the need for a large number of technical personnel at the reactor site. More modules could be added later to allow for additional needed capacity.

D.2.2 Technical Characteristics

A schematic of the safety systems for the modular, low-power CAREM reactor is shown in Figure D.1 [INVAP, 1991]. The CAREM reactor has an integrated primary circuit, meaning that the steam generator and other components of the primary system are contained within a single pressure vessel. A once-through, helical tube steam generator is located above the core at the top of the downcomer. The density difference between the hot water exiting the reactor core into the riser and the cooler reactor water exiting the steam generators in the downcomer provides the natural convective flow of water in the primary loop through the reactor core. A vapor chamber, located in the upper part of the pressure vessel, absorbs pressure transients.

The shutdown condenser, in the upper part of the pressure vessel, is used to transfer decay heat after reactor shutdown from the reactor coolant to an external evaporator in the containment structure. Flow in the shutdown cooling system is by natural convection. The two elevated water tanks provide enough water to the evaporator to ensure core cooling for 1 week after shutdown.

The actively initiated, passively operated water injection system is used to keep the core underwater during a loss of coolant accident (LOCA). The injection of water into the pressure vessel will cool the core by direct water evaporation. During a LOCA, the steam generated from the core will pass into the steel primary containment vessel (PCV) and condense. Passive air cooling of the PCV will dissipate the heat and condense the steam.

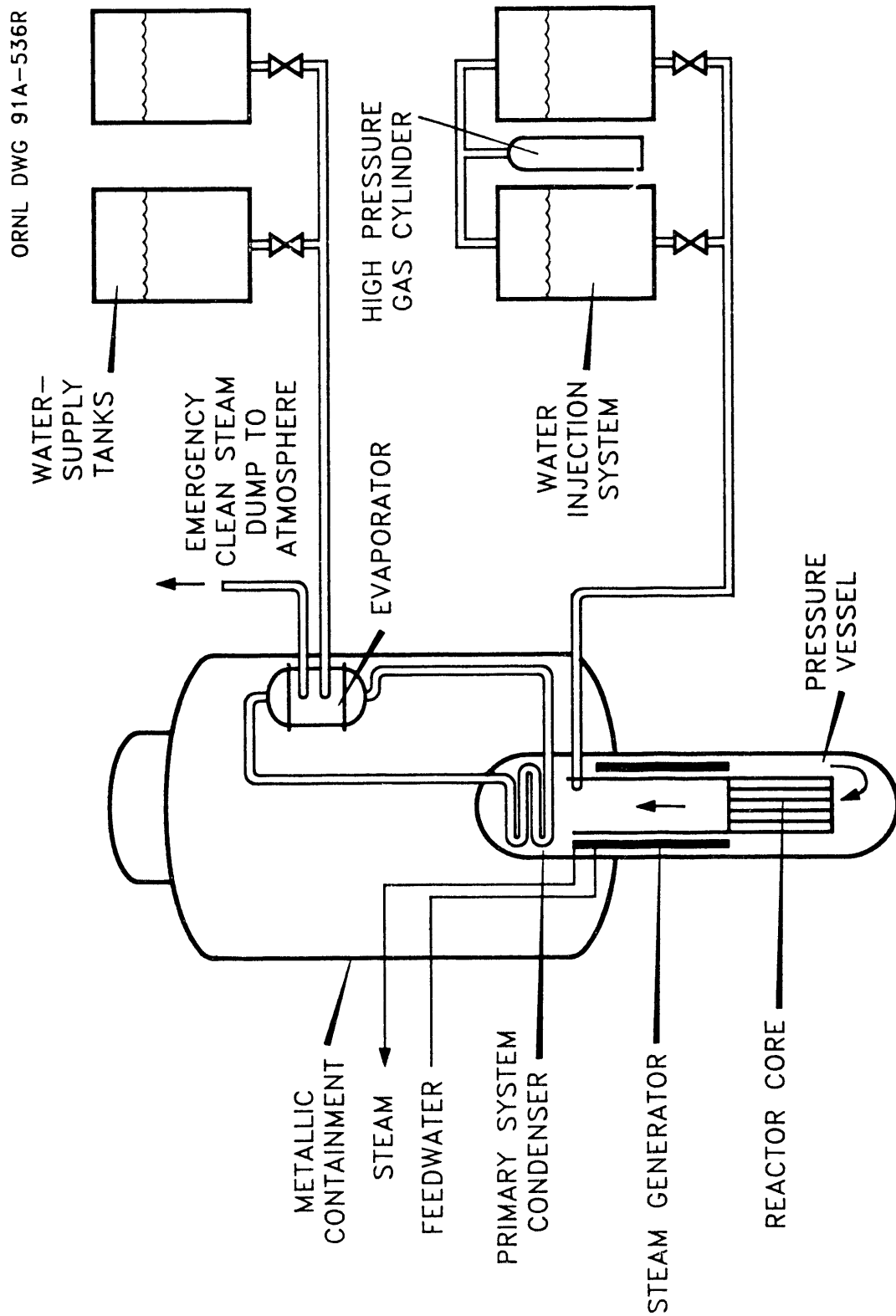

Fig. D.1. Schematic of modular low-power CAREM Reactor.

D.3 JAPAN

D.3.1 HITACHI SMALL BWR

D.3.1.1 General Characteristics

The Hitachi Small Boiling-Water Reactor (HSBWR-600) is a proposed natural-circulation BWR with a rated capacity of 600 MW(e). The primary design objectives of the HSBWR, designed by Hitachi, Ltd. of Japan, are as follows [Kataoka, 1988]:

1. to standardize the design of the reactor building and improve the seismic resistance of the core;
2. to extend the reactor operating cycle to ~2 years, primarily by decreasing the power density;
3. to simplify the reactor components and systems and, thus, improve the operability and maintainability of the reactor;
4. to simplify and improve operating procedures under abnormal conditions by using passive safety concepts; and
5. to decrease capital costs by reducing the construction period.

D.3.1.2 Technical Characteristics

A schematic of the HSBWR is shown in Fig. D.2 [Kataoka, 1988] with key design specifications given in Table D.1. A major simplification of the reactor design is the elimination of pumped recirculation systems, steam separators, and pumped emergency core cooling systems (ECCS). Natural circulation is used for steady-state core cooling. A riser, 9 m in height, is placed above the reactor core to enhance this circulation. The elimination of the steam separators will further increase the rate of natural circulation. The lower power density achieved by natural circulation allows the reactor to operate continuously for 23 months.

The residual heat removal (RHR) system is designed to provide long-term core cooling after normal reactor shutdown or reactor scram. The RHR system uses injection pumps and heat exchangers to reduce the coolant temperature of the 1,800 MW(t) reactor to 52°C within 20 h.

The elimination of large pipes below the top of the reactor core greatly decreases the risk during a postulated LOCA resulting from pipe breaks. The usual pumped ECCS has been replaced by the steam-driven Reactor Core Isolation Cooling (RCIC) system and accumulators that are capable of supplying emergency coolant to the core for 1 d after reactor scram. The RCIC system provides emergency cooling water during loss of AC power (station blackout) or after small break LOCAs. It is powered by steam from the reactor vessel.

In the event of a large LOCA or anticipated transit without scram (ATWS) accident, activation of the safety relief valves (SRVs) will allow the automatic depressurization

ORNL DWG 91A-539R

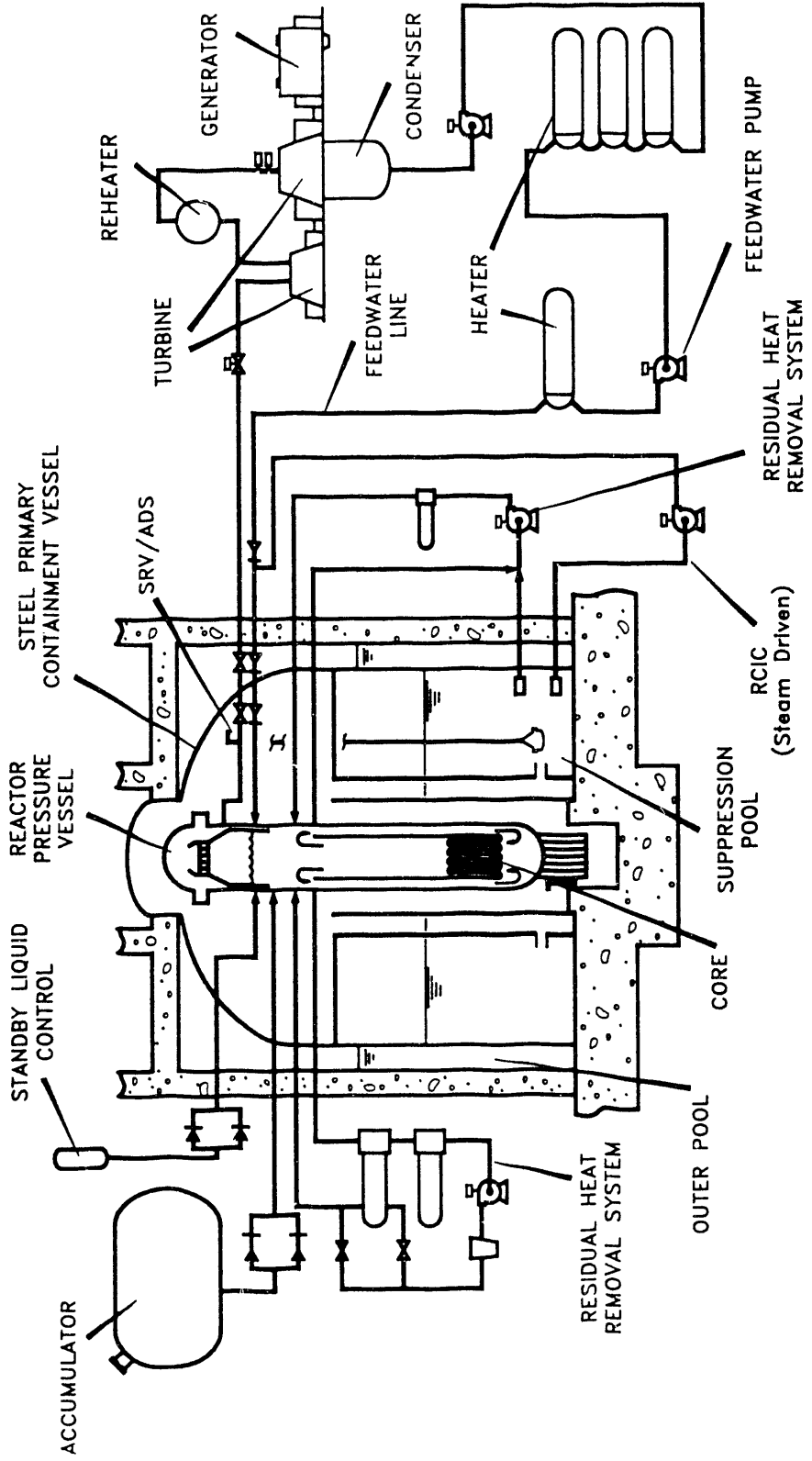

Fig. D.2. Schematic of the Hitachi Small Boiling-Water Reactor.

Table D.1 Key design specifications of the Japanese HSBWR-600

| | |
|--------------------------|--------------------------|
| Reactor type | Natural-circulation BWR |
| Thermal power | 1,800 MW(t) |
| Electrical power | 600 MW(e) |
| No. of fuel assemblies | 708 (8 x 8 design) |
| Average U-235 enrichment | 3.6% |
| Operating cycle | 23 months |
| Average burnup | 39,000 MWd/M(t) |
| Fuel assembly height | 3.7 m total/3.1 m active |
| Core diameter | 4.65 m |
| Volumetric power density | 34.2 kW/L |
| Size of reactor building | 47 m x 47 m x 47 m |
| Size of turbine building | 47 m x 58 m x 45 m |
| Construction period | 32 to 36 months |

system (ADS), along with the borated water injection from the accumulators, to decrease reactivity, shut down the reactor, and cool the reactor core.

The PCV, constructed of steel, allows for natural heat removal by conduction from inside the containment through the PCV wall to the outer pool. The outer pool has adequate heat removal for 3 d before operator intervention is necessary.

The fuel assemblies are designed to minimize seismic resonance between the core and reactor building. This allows the entire plant layout to be standardized regardless of local geologic considerations, such as ground firmness.

As a result of these design enhancements, the volume of the reactor building is ~50% of that for current BWRs of equal electrical capacity. The construction period from initial ground breaking to commercial operation is estimated to be 32 to 36 months.

D.3.2 MITSUBISHI SIMPLIFIED PWR

D.3.2.1 General Characteristics

The Mitsubishi Simplified PWR has been designed as both a 300 MW(e) (MS-300) and a 600 MW(e) (MS-600) power plant [Matsuoka, 1991]. Basic design work has focused primarily on the larger MS-600 design. Mitsubishi Heavy Industries of Japan has begun a more detailed design and testing phase that will continue through 1996. In the near future, the program, in cooperation with Japanese utilities, will be extended to develop the four-loop, 1200 MW(e) plant. The program is a top-priority program for development of the next generation of PWRs in Japan. It is the first fully Japanese-designed, large PWR. The design objectives are to develop a plant that has improved safety, better economy, and higher reliability. In order to meet these objectives, the MS-600 design uses horizontal steam generators, a low-power density core, top-mounted in-core instrumentation, passively cooled drive mechanisms for the control rods, and a hybrid safety system.

This reactor is the first Western reactor proposed to use horizontal steam generators. Based on (1) engineering studies, (2) experience in Finland with Soviet reactors with horizontal steam generators, and (3) chemical industry experience, this is a major improvement. Vertical steam generators have historically been the most troublesome mechanical component in current Western PWRs and the major cause of downtime for repair and inspection. Horizontal steam generators, when compared with the more common vertical designs, potentially offer a number of advantages, such as higher reliability, increased resistance to seismic events, and significantly enhanced safety by natural-circulation cooling under accident conditions. While these advantages have been known for many years, it takes a significant engineering effort to modify plant layout and design for horizontal steam generators.

D.3.2.2 Technical Characteristics

The 600 MW(e) Mitsubishi Simplified PWR [Matsuoka, 1991a] is shown in Fig. D.3, and the principal design parameters of the reactor are given in Table D.2. The MS-600 uses a double containment that consists of a spherical steel primary containment vessel (PCV) and a concrete-filled steel secondary containment vessel. The primary reactor coolant system, the spent fuel pit, and the gravity injection tanks are located within the PCV. The annulus inside the secondary containment is vented through a charcoal filtration system that traps airborne contaminants.

A low-power density reactor core, surrounded by radial neutron reflectors, allows the MS-600 to operate on a 24-month fuel cycle with lower fuel costs than conventional PWRs. The use of top-mounted in-core instrumentation eliminates all bottom penetrations in the pressure vessel. This has simplified the design of the lower containment structure, lowered the elevation of the pressure vessel in containment, and, thus, improved seismic resistance. While conventional control rod drive mechanism (CRDM) coils require forced cooling, the MS-600 uses high-temperature windings for the CRDM coils that simplify the reactor vessel head design and are passively cooled. High-efficiency reactor coolant pumps reduce AC power demands and are fitted with high-temperature seals to avoid seal failure and a possible small, secondary LOCA via the seals in a reactor accident when the seals become hot.

ORNL DWG 91A-535

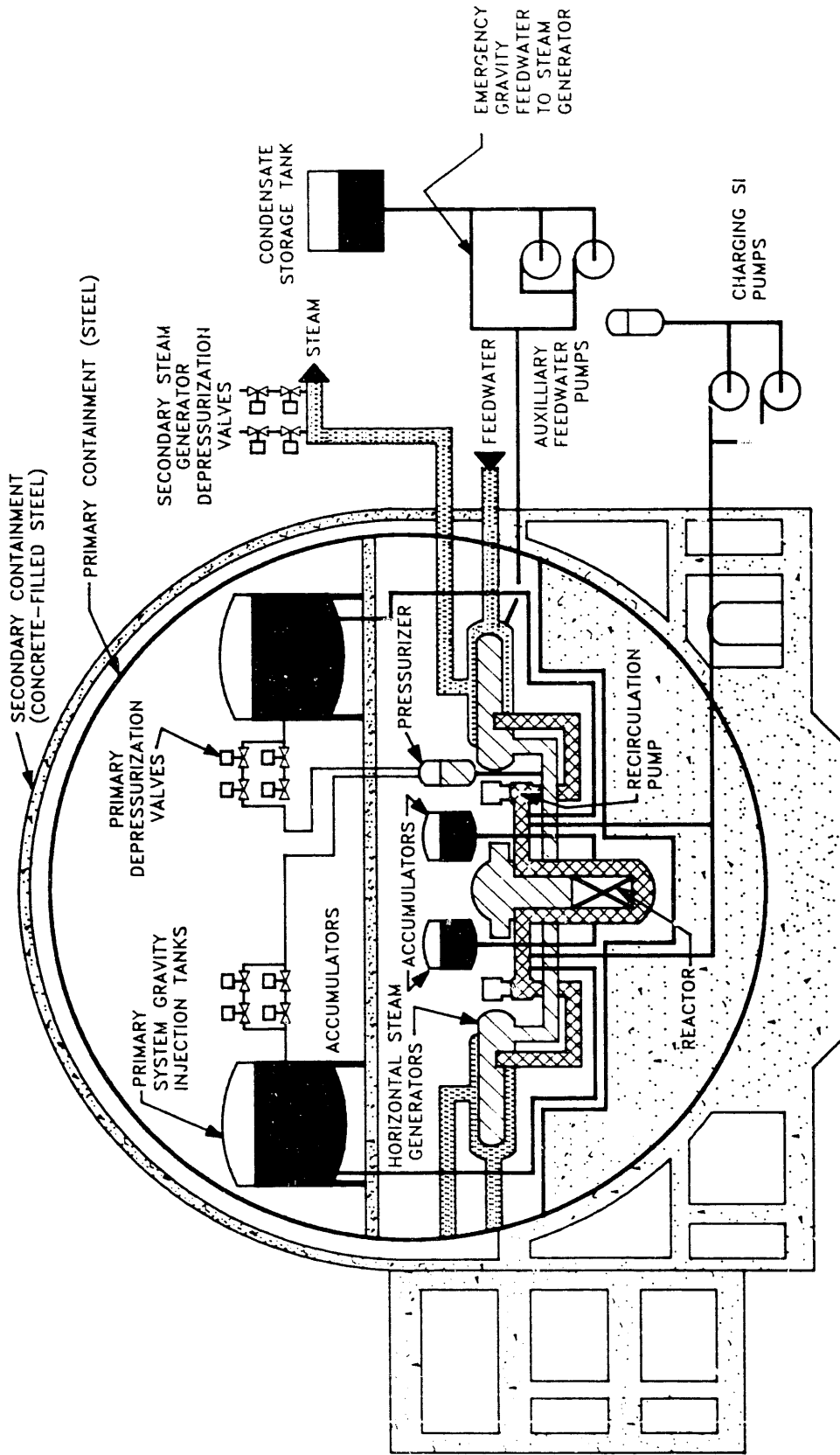

Fig. D.3. Mitsubishi Simplified Pressurized-Water Reactor.

Table D.2 Principal design parameters of the Mitsubishi Simplified PWR

| Parameters | MS-300 Design | MS-600 Design |
|--|---|---------------|
| Thermal power, MW(t) | 854 | 1825 |
| Electrical power, MW(e) | 300 | 630 |
| Reactor core | Low core power density | |
| Fuel Assemblies | | |
| Array size | 14 x 14 | 15 x 15 |
| Number | 121 | 157 |
| Turbine type | TC2F40 | TC4F40 |
| Containment vessel | Steel primary containment with concrete-filled, steel secondary containment | |
| Reactor coolant system | | |
| Number of loops | | 2 |
| Operating pressure, kg/cm ² g | | 157 |
| Coolant temperatures | | |
| Reactor inlet, °C | 302.5 | 290.6 |
| Reactor outlet, °C | 325.0 | 325.0 |
| Steam generators | | |
| Type | Horizontal, U-Tube | |
| Number | | 2 |
| Steam generator pressure, kg/cm ² g | 62 | 58 |
| Reactor coolant pumps | | |
| Type | High efficiency with improved seals | |
| Number | | 2 |

The horizontal steam generators are the most unique feature, compared with other evolutionary technology reactors, and potentially are a major improvement. The lower-than-expected reliability of vertical steam generators is a consequence of sludge buildup and subsequent corrosion at the bottom of the steam generator where tubes enter the tube sheet. At this location, the tubes are highly stressed by (1) the weight of the tubes, and (2) the large temperature differences between feedwater and primary reactor water. The most highly stressed location in the vertical steam generator has the most corrosive chemical conditions. In horizontal steam generators, the weight of the tubes is supported by horizontal bars (not the tubesheet) and sludge falls by gravity away from the tubes and tubesheet. The horizontal configuration also ensures natural primary coolant circulation. In vertical steam generators, noncondensable gases can collect at the top of the tubes and prevent natural circulation of primary system water if reactor recirculation pumps are turned off.

A hybrid safety system, using both active and passive concepts, is proposed for the MS-600. The basic idea of the MS-600 design is to use active safety systems to terminate credible accidents without flooding the PCV and, thus, minimize post-accident recovery times. The most probable accidents are relatively small; thus, only small active safety systems are needed. Passive systems and systems which require activation, but which are passive in operation, which usually flood the containment to remove core decay heat, are only used for improbable, severe accidents such as a large break LOCA or in the event of a failure of the active safety systems. Thus, the advantages of both active and passive systems are obtained.

The active safety systems consist of conventional PWR safety injection pumps, auxiliary feedwater pumps, and small emergency diesel generators. These systems are used for very small pipe breaks, steam generator tube ruptures, and non-LOCA transients.

Passive safety is provided by the automatic depressurization system (ADS), the advanced accumulators, the gravity injection tanks, and the horizontal steam generators (refer to Fig. D.3). During a LOCA, the ADS will rapidly depressurize the reactor coolant system (RCS). The advanced accumulators, using a fluidic flow control device, will then provide a high initial flow rate of cooling water to the reactor core followed by a prolonged, low flow rate. As the RCS pressure continues to drop, gravity injection tanks will inject enough water to flood the lower containment. Natural-circulation core cooling is provided by the horizontal steam generators. The secondary side of the steam generators is supplied water by gravity from a condensate storage tank. This system, after actuation, will provide 3 d of cooling by boiloff of clean water in the steam generators with steam dumped to the atmosphere before operator intervention is required to refill the safety tank. Heat is also dumped to the environment through the containment systems.

D.3.3 SYSTEM-INTEGRATED PWR

D.3.3.1 General Characteristics

The Japanese System-Integrated Pressurized-Water Reactor (SPWR) is a 350 MW(e) [1,100 MW(t)] PWR that has a fully integrated primary cooling system within the reactor pressure vessel (RPV). The SPWR, designed by Japan Atomic Energy Research Institute (JAERI), has a passive, natural-circulation ECCS using boron injection similar in concept to the PIUS-type reactors, such as the Secure-P. Boron injection systems, along with inherent reactivity controls, replace the conventional control rod drive system.

The SPWR is part of a larger program to investigate reactors with passive and inherent safety. As a reactor concept, it has most of the characteristics of a PRIME reactor. There is a spectrum of reactor concepts, with this machine on the boundary between evolutionary technology reactors and PRIME reactors, as defined herein.

D.3.3.2 Technical Characteristics

Two basic reactor designs, hot vessel and cold vessel, are being considered. The hot vessel design contains an internal boron tank with the hotter primary coolant flowing in the annulus between the tank and RPV outer wall (thus the term "hot vessel"). The cold vessel design does not use the internal boron tank but rather places the cooler boron water in the annulus at the RPV outer wall and directs primary coolant through a second annulus farther from the RPV wall (thus the term "cold vessel"). Options are being designed that place the main circulating pump (MCP) in either the hot leg or cold leg of the primary coolant system (PCS).

Current SPWR design work is focusing on the hot vessel design with the MCP in the hot leg of the PCS [NEA, 1991]. This version of the SPWR is shown in Fig. D.4, with principal design parameters given in Table D.3 [Forsberg, 1990]. During normal operation, the reactor core is immersed in water of a low boron concentration. The highly borated water (4,000 ppm) in the boron tank is separated from the PCS by means of a hot/cold interface zone beneath the reactor core and is prevented from entering the core by means of hydraulic pressure valves at the top of the boron tank. These hydraulic valves are held closed by the force of water from the MCP. The coolant flow during normal operation is shown by the arrows in Fig. D.4.

If the flow of primary coolant is reduced below the minimum level necessary to hold the hydraulic valves closed, a weight attached to the valves will open them up and start the flow of borated water. Thus, a loss of AC power, MCP failure, or LOCA will cause the hydraulic valves to open, and flow by natural-circulation would flood the core with cool, high-boron water. Figure D.4 also shows coolant flow during emergency operation. Coolers are located in the borated water tank to maintain the temperature at 150°C during reactor operation. Passive operation of the ECCS is supplemented by installation of two active, rapid-opening valves between the steam generator and the top of the boron poison tank. This active system can be used to shut down the reactor in 5 s after valve activation, assuming the MCP is operating at full capacity.

ORNL DWG 89A-92R

EMERGENCY OPERATION

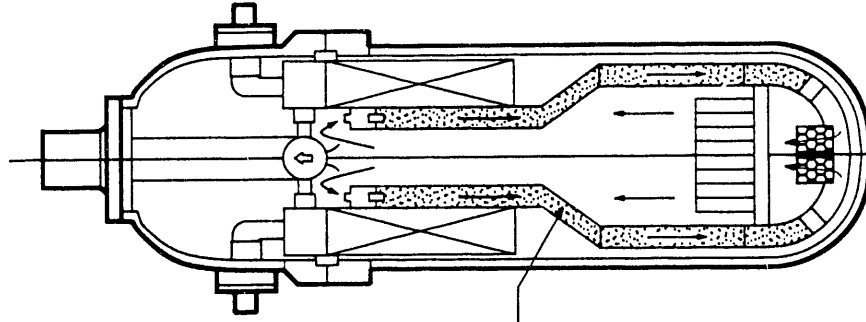

NORMAL OPERATION

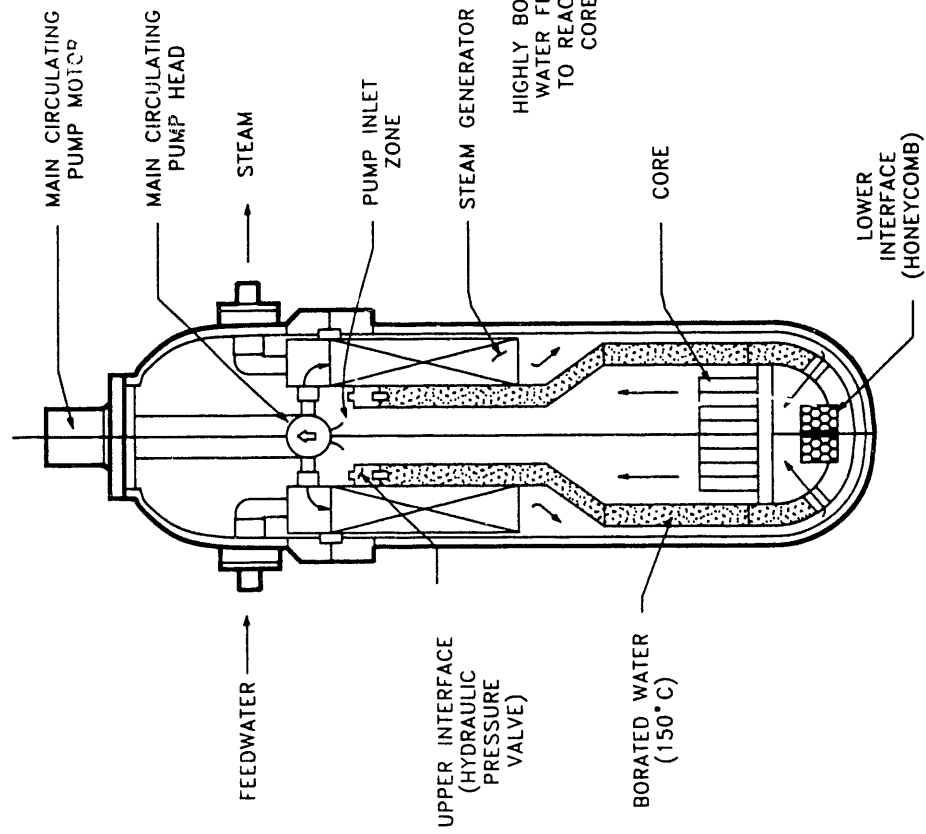

Fig. D.4. System-integrated pressurized water reactor.

Table D.3 Principal design parameters of the System-Integrated Pressurized-Water Reactor

| | |
|--|-------------------------|
| <u>Reactor</u> | |
| Thermal power | 1,100 MW(t) |
| Electrical power | 350 MW(e) |
| Coolant inlet/outlet temperature | 280° C/310° C |
| Coolant flow rate | 24,000 t/h |
| Core outlet pressure | 13 MPa |
| Core pressure drop | 0.035 MPa |
| Steam generator pressure drop | 0.18 MPa |
| Reactor pressure vessel inside diameter | 6.6 m |
| <u>Core</u> | |
| Equivalent core diameter/height | 2.89 m/2.0 m |
| Core average power density | 84 MW(t)/m ³ |
| <u>Main circulating pump (one unit)</u> | |
| Flow rate | 26,000 t/h |
| Delivery pressure | 0.23 MPa |
| Rotating speed | 600 rpm |
| <u>Steam generator</u> | |
| Steam temperature/pressure | 285° C/5 MPa |
| Feed water temperature | 210° C |
| Steam flow rate | 2,000 t/h |
| Steam generator inner/outer diameter | 3.2/6.1 m |
| Steam generator height | 7.6 m |
| <u>Poison injection system</u> | |
| Natural boron content | >4,000 ppm |
| Poison temperature | 150±10° C |
| Number of hydraulic pressure valves | 3 |
| Number of rapid-opening valves | 3 |
| <u>Hydraulic pressure valves</u> | |
| Valve port | 200 mm |
| Cylinder diameter | 300 mm |
| Piston diameter | 290 mm |
| Annular space gap diameter | 10 mm |
| Estimated leakage flow | 50 L/s |
| Percent of rated main circulating pump flow required for closure | 40% |
| Attached weight | 170 kg |
| Force supplied to piston at full power | 1.26 tons |

Because the SPWR does not have a control rod drive system, the reactor power is controlled by adjusting the boron concentration of the primary coolant water during normal operation. This active control system, separate from the ECCS boron injection system, is supplemented by the inherent control offered by the negative temperature and void coefficients of the reactor core. Reactivity change due to fuel burnup is also compensated for by adjusting the boron concentration.

The top of the RPV serves as a pressurizer with integral electric heater. The once-through, helical coil steam generator is divided into four units surrounding the core riser. Having no large-scale piping and no openings below the core ensures that the core will remain covered for an extended period of time after a LOCA.

D.3.4 TOSHIBA 900

D.3.4.1 General Characteristics

The Toshiba TOSBWR-900P reactor is a proposed 310 MW(e) [900 MW(t)] natural-circulation BWR designed by Toshiba Corporation of Japan. The primary design objectives are to simplify the reactor systems to decrease capital costs, reduce construction schedules, decrease operational complexity, and use passive safety concepts to enhance reactor safety.

D.3.4.2 Technical Characteristics

A schematic of the Toshiba 900 reactor is shown in Fig. D.5 [Oka, 1989]. The main design parameters are given in Table D.4. Natural circulation in this BWR design is enhanced by the use of steam drums that eliminate the need for steam separators and dryers within the RPV. Reactor coolant makeup and emergency core cooling are accomplished by using accumulators, a gravity-driven reactor core cooling system, an automatic depressurization system, passive containment spray, and a passive containment cooling system that uses sea water as a heat sink.

The TOSBWR-900P reactor core contains 388 fuel assemblies of the 8 x 8 design that generate 900 MW(t) power with a relatively low power density of 40 kW/L. The size of the RPV has been reduced (see Table D.4) by using shorter fuel assemblies and eliminating the need for steam separators and dryers in the reactor vessel. A gravity-driven CRDM is mounted on top of the RPV. This top-mounted design, which eliminates all penetrations in the bottom of the reactor pressure vessel simplifies the design of the lower containment structure, simplifies maintenance requirements, and lowers the elevation of the pressure vessel in containment. This improves seismic resistance.

High- and low-pressure accumulators provide for coolant makeup and short-term emergency cooling of the reactor core. Long-term decay heat removal is provided by the Gravity-Driven Cooling System (GDCCS), which provides sufficient water to the RCS to completely flood the reactor vessel. This same system provides water for the passive containment spray that maintains containment pressure and temperature below design limits. An automatic depressurization system reduces RCS pressure to allow the gravity-driven safety systems to inject coolant.

Containment heat is ultimately removed by the natural-circulation Seawater Coolant System (SCS). After the containment is flooded, natural-circulation flow will remove decay heat from the RPV. The outer wall of the flooded containment is also the inner wall of a seawater-filled compartment used for heat exchange. The seawater compartment is connected to the sea by upper and lower cooling pipes. Decay heat is transferred from the flooded containment to the seawater compartment, where natural circulation of the seawater through the compartment provides heat removal [Forsberg, 1990].

ORNL DWG 89A-10433R

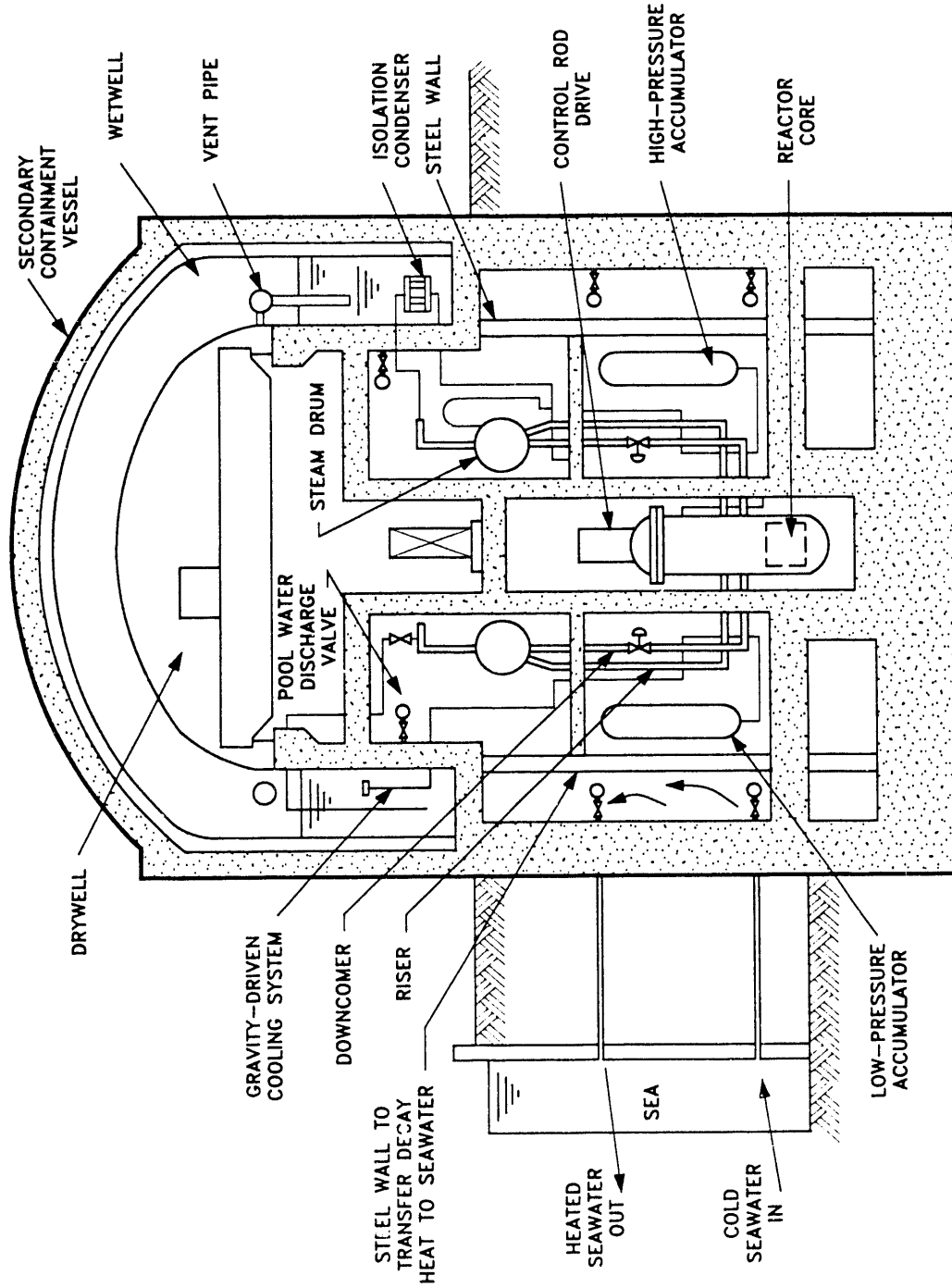

Fig. D.5. Toshiba TOSBWR-900P Reactor.

Table D.4 Main design parameters of the Toshiba TOSBWR-900P Reactor

| | |
|---------------------------|----------------------------|
| Reactor type | Natural-circulation BWR |
| Thermal power, MW(t) | 900 |
| Electrical power, MW(e) | 310 |
| Type of fuel assemblies | 8 x 8 array |
| Number of fuel assemblies | 388 |
| Effective core size | 3.4 m diam. x 2.5 m height |
| Power density, kW/L | 40 |
| Size of pressure vessel | 4.7 m I.D. x 17 m height |
| Operating pressure, atm | 72.1 |

D.4 UNITED STATES

D.4.1 ADVANCED PASSIVE-600

D.4.1.1 General Characteristics

The Advanced Passive-600 (AP-600) is a proposed 600 MW(e) PWR designed by Westinghouse Electric Company and their subcontractors¹ with financial support from the Electric Power Research Institute (EPRI) and the U.S. Department of Energy (DOE). The program includes cooperative work with organizations in Japan and Italy. The major design objectives of the AP-600 program are to reduce capital cost, shorten the construction schedule, improve plant safety, reduce occupational radiation exposure, increase plant availability, and reduce maintenance and inspection requirements. These objectives are met by the use of passive and active initiation/passive operation safety systems to perform all safety-related functions. The passive and active initiation/passive operation safety features of the AP-600 perform the following functions: emergency core decay-heat removal, reactor coolant inventory control, short-term LOCA injection, long-term LOCA recirculation, containment heat removal, and containment spray [Conway, 1988].

D.4.1.2 Technical Characteristics

The Westinghouse AP-600 reactor is shown in Fig. D.6, with major design specifications given in Table D.5. The AP-600 reactor is designed with a low-power-density core fueled with 145 fuel assemblies and surrounded by a stainless steel and water radial neutron reflector to reduce neutron leakage and, thus, reduce enrichment and fuel cycle costs. Westinghouse 17 x 17 Optimized Fuel Assembly (OFA) fuel assemblies are used and yield an estimated fuel cycle length of 18 months. Soluble boron and burnable poisons are used for shutdown and fuel burnup reactivity control. This reduces use of control rods.

The RCS is unique in that the hermetically sealed reactor coolant pumps (RCPs) are integral to the steam generator. Two modified Westinghouse Model 8006 canned motor pumps, similar to those used at the Shippingport reactor, are welded to each of the two Westinghouse Model F steam generators (vertical "U"-tube type). Separate RCP supports are thereby eliminated. The use of hermetically sealed pumps improves plant safety by eliminating the possibility of a shaft seal LOCA.

The safety systems of the AP-600 consist of three primary components—the Passive Residual Heat Removal (PRHR) System, the Passive Safety Injection System (PSIS), and the Passive Containment Cooling System (PCCS). The PRHR system is designed to remove core decay heat in the event that normal feedwater systems are not operational. The PRHR system, which replaces the safety grade auxiliary feedwater system, consists of two in-containment heat exchangers which transfer heat in a natural-circulation loop between the primary circuit and the In-containment Refueling Water Storage Tank (IRWST), which is capable of

¹ Includes Bechtel; Burns and Roe Co.; Avondale Industries; CBI Services, Inc.; M-K Ferguson Co.; Southern Company; and Ansaldo.

ORNL DWG 91A-537

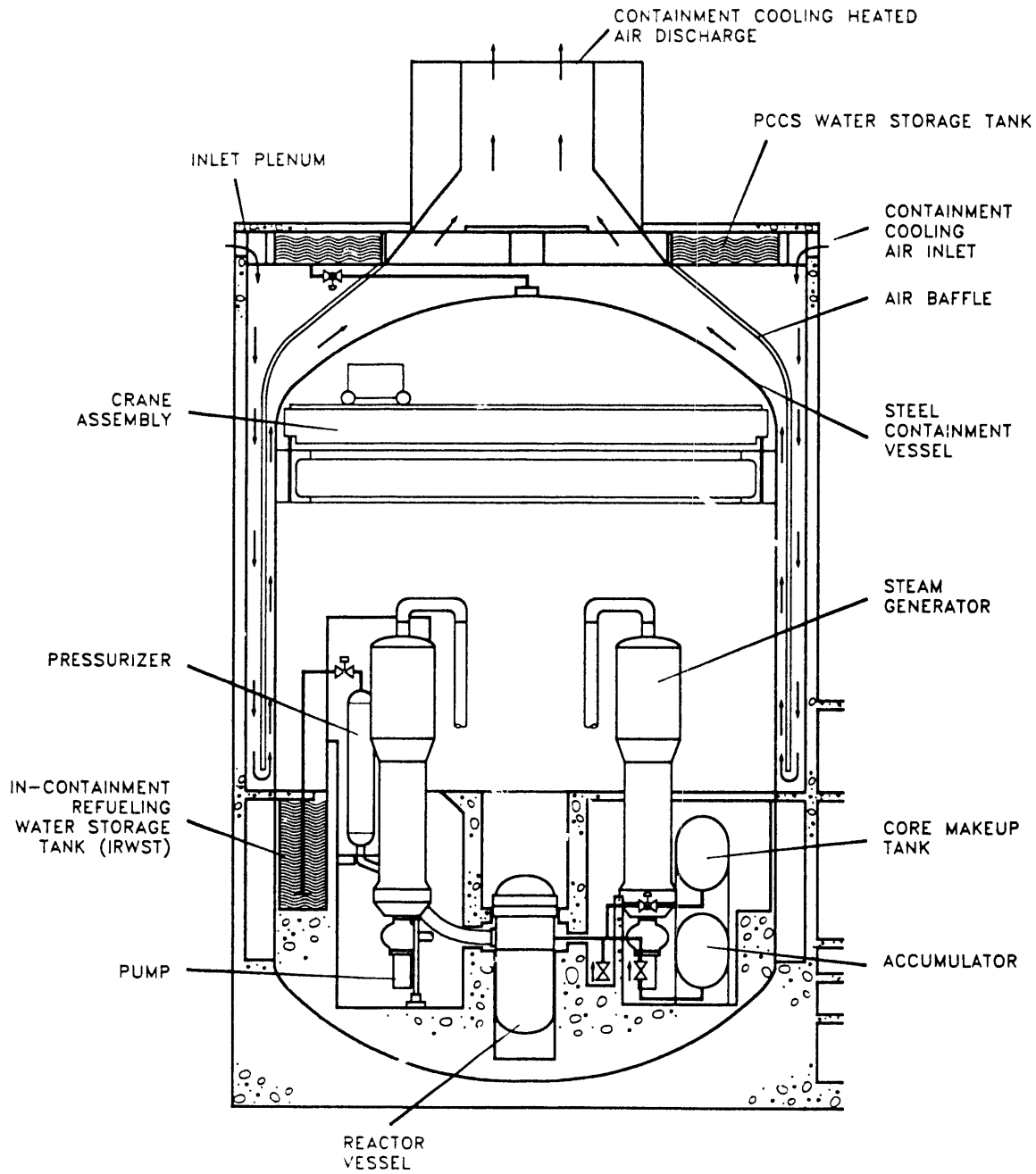

Fig. D.6. Westinghouse Advanced Passive-600 Reactor.

Table D.5 Major design specifications of the Advanced Passive-600 Reactor

| | |
|-----------------------------------|--------------------------|
| Thermal power, MW(t) | 1812 |
| Electrical power, MW(e) | 600 |
| Type of fuel assemblies | Westinghouse 17 x 17 OFA |
| Number of fuel assemblies | 145 |
| Active fuel length, ft | 12 |
| Core loading, MTU | 61.0 |
| Linear heat rating, kW/ft | 3.8 |
| Average power density, kW/L | 73.9 |
| Reactor pressure vessel I.D., ft | 13.1 |
| Type of steam generators (SGs) | F-1000, vertical U-tubes |
| Number of steam generators | 2 |
| Primary coolant flow rate, gpm/SG | 92,060 |
| Steam flow rate per SG, lb/h | 3.9×10^6 |
| Number of reheat stages | 1 |
| Number of feedwater heaters | 5 |

absorbing decay heat for several days without operator intervention or use of active feedwater systems. System activation using air-operated valves is automatic if AC power fails.

Reactor coolant makeup after a LOCA is provided by the PSIS, which replaces the conventional safety injection pumps, safety grade diesel generators, and cooling water systems. The PSIS consists of two core makeup tanks, two accumulators, and the IRWST as shown in Fig. D.6. There are three subsystems that act sequentially, if needed, to ensure reactor core cooling:

1. The two core makeup tanks, with a combined capacity of 4,000 ft³, are filled with borated water and maintained at the same pressure as the RCS cold leg. After a small-break LOCA, the tanks use gravity to provide water safety injection to the pressure vessel. This system is activated by air-operated valves that fail open on loss of power or control signal.
2. Large-break LOCAs require additional coolant makeup capacity that is supplied by the two accumulator tanks. Each 2,000 ft³ tank contains 1,700 ft³ of borated water with a 700 psig overpressure of nitrogen. This system is initiated after the primary system pressure decreases from 2200 psi to 700 psi.
3. The third system provides long-term reactor core cooling after an accident. A series of valves connected to the pressurizer serves as the automatic depressurization system. After RCS depressurization, long-term coolant makeup is supplied by the IRWST system, which has an initial 10-hour supply of coolant water. After the IRWST has emptied, the containment area will be flooded above the highest RCS location and, thus, continuous core cooling is established when coupled with the containment cooling system.

A PCCS is provided to remove heat from the steel reactor containment. The operation of PSIS (above) results in steam from the reactor core being released to the containment. Cooling the containment condenses the reactor steam inside containment. Steam condensation removes heat, reduces containment pressure, and washes cesium and iodine from the containment atmosphere. The water (condensed steam) flows back via the IRWST to cool the reactor core. The PCCS consists of large tanks of water above the containment structure that allow gravity drain of the water onto the outside of steel containment vessel at an initial flow rate of 250 gal/min. Opening the air dampers will supply natural-circulation air cooling of the external surface of the steel containment. The air and evaporated water exhaust through an opening in the roof of the shield building. The water tanks can supply containment coolant for 3 d before operator intervention is required to refill the tanks.

D.4.2 SIMPLIFIED BWR

D.4.2.1 General Characteristics

The SBWR is a proposed 600 MW(e) natural-circulation BWR designed by General Electric² with financial support from the EPRI and the DOE. The primary design objectives for the SBWR are as follows [NRC, 1987]:

1. Power generation costs must be superior to coal.
2. Plant safety systems should be simpler than those used in current designs.
3. The design should be based on existing technology.
4. The design should considerably shorten construction schedules.
5. The plant should have an electrical rating in the 600 MW(e) range.

These objectives are achieved in the SBWR design by providing natural-circulation core cooling, a gravity-driven ECCS, a passive containment cooling system, and a low-power density core.

D.4.2.2 Technical Characteristics

A schematic of the SBWR is shown in Fig. D.7. The design of the large RPV allows natural-circulation coolant flow and reduces the core power density to about 36 kW/L. This lower power density will reduce fuel-cycle costs by as much as 15% over the conventional types, with forced circulation designs, and extend the cycle length to 24 months. Design simplification occurs by eliminating the recirculation pumps, control equipment, and other safety-grade systems. All large pressure vessel piping is placed above the reactor core to prevent large-break LOCAs, which could drain the reactor vessel of water, and to extend the time the core is covered during postulated accidents.

An isolation condenser in the elevated pool provides normal removal of decay heat and will control reactor pressure automatically without the need to remove fluid from the pressure vessel. This system is used when the RPV is isolated from the turbine condenser. For decay heat removal, valves open and steam from the reactor core enters a condenser submerged in a pool of water. The steam is condensed and flows by gravity back to the reactor core. The need for conventional BWR safety relief valves is avoided. Nonsafety grade systems, such as feedwater pumps and small diesel generators, allow more conventional, active equipment to terminate credible accidents without flooding the PCV and, thus, minimizing post-accident recovery times. This is similar to the hybrid safety concept used in the Mitsubishi SPWR.

The gravity-driven ECCS consists of low-pressure elevated pools, makeup vents, and depressurization valves. In the event of a LOCA, the depressurization valves will reduce RVP and allow water from the elevated pools to flow by gravity to the core. The drywell

² In cooperation with Bechtel Power, Southern Company Services, Burns and Roe, Foster-Wheller Energy Applications, Massachusetts Institute of Technology, University of California-Berkeley, Hitachi, Toshiba, Ansaldo, ENEL, ENEA, GKN, ECN, NUCON, and KEMA.

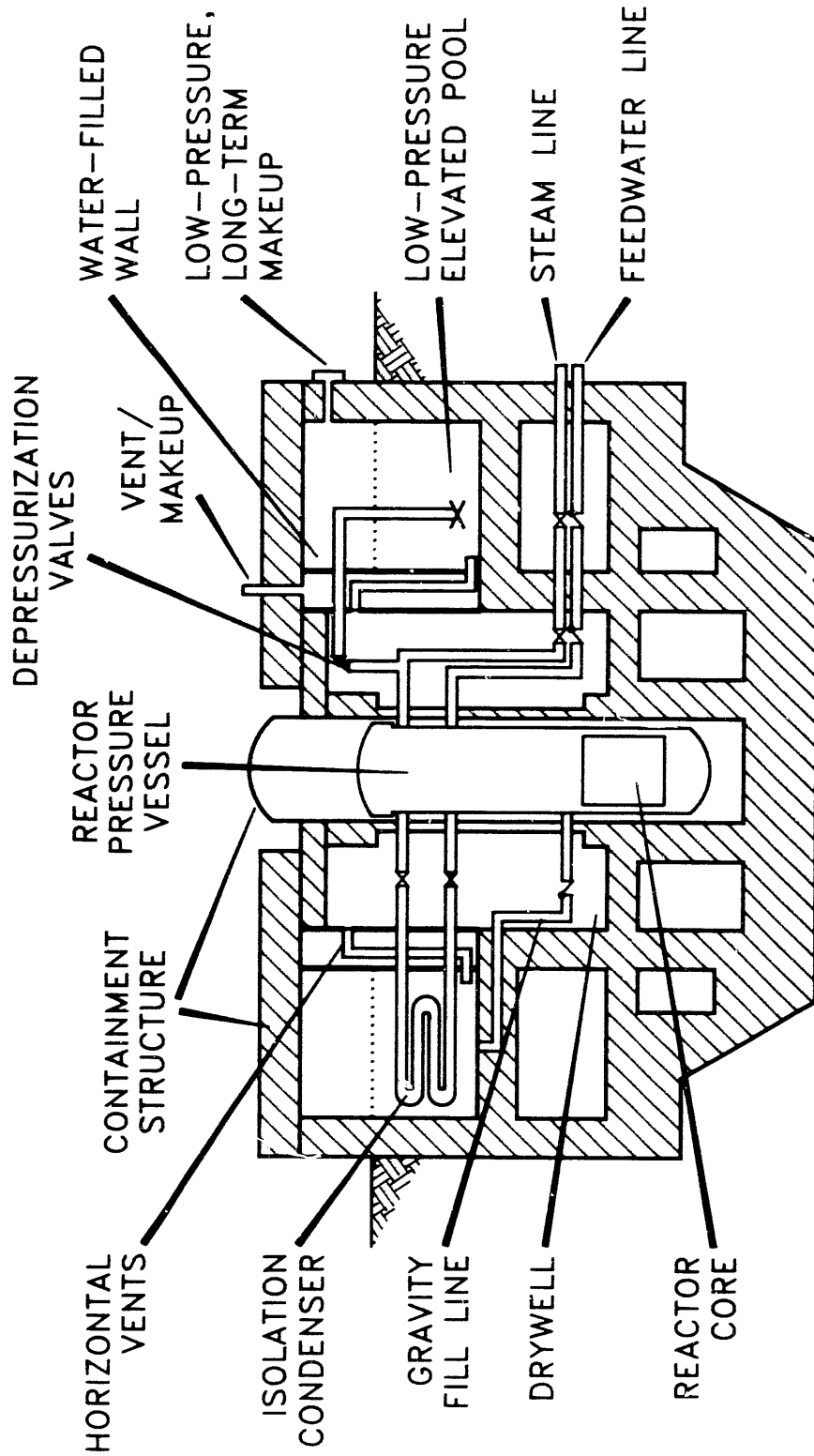

Fig. D.7. General Electric Simplified Boiling-Water Reactor.

area around the reactor vessel will also be flooded and, thus, activate the PCCS. The PCCS consists of a water-filled wall between the drywell area and the elevated pools. Decay heat removed by the ECCS will be transferred to the "water-wall," which is cooled by natural-circulation water flow (similar to the Toshiba Seawater Coolant System). Passive containment cooling will continue for 3 d before operator intervention is required to replenish the water supply of the elevated pools.

D.5 UNITED KINGDOM

D.5.1 SAFE INTEGRAL REACTOR

D.5.1.1 General Characteristics

The Safe Integral Reactor (SIR) is a proposed 320 MW(e) PWR being developed by a joint USA-UK team consisting of ABB-Combustion Engineering; Stone and Webster; Rolls Royce and Associates, Ltd.; and the United Kingdom Atomic Energy Authority [NEA, 1991; Andrews, Hall, and Gibson, 1991]. SIR has several unusual characteristics for evolutionary technology reactors:

1. The reactor provides total passive safety for many hours against accidents of the type that occurred at TMI. This is a consequence of the high water inventory of the primary reactor system, which is significantly higher than other reactors, except the PIUS reactor—a PRIME reactor.
2. The entire primary nuclear system (core, steam generator, etc.) is located within a very large pressure vessel. This maximizes shop fabrication and minimizes field construction.

D.5.1.2 Technical Characteristics

A schematic of the SIR and the associated pressure suppression system is shown in Fig. D.8. The SIR has a fully integrated PCS. This means that the primary system components, including the reactor core, steam generators, pressurizer, and reactor coolant pumps, are enclosed in a RPV. Passive safety systems consist of the inherent safety of an integrated reactor design, a larger volume of primary coolant than conventional PWRs, a passive pressurizer system, a pressure suppression containment system, and a system designed to enhance natural circulation in both the primary and secondary coolant systems. The integrated primary cooling system contained within the pressure vessel is detailed in Fig. D.9. Major design parameters are given in Table D.6. The integrated design requires a large pressure vessel and, therefore, a large water inventory that provides short-term emergency core cooling. The core is near the bottom of the pressure vessel and is placed under a tall riser to enhance natural circulation. Twelve once-through steam generators and six sealed primary circulation pumps are located along the periphery of the pressure vessel, as shown in Fig. D.9.

The integrated primary circuit provides a number of safety-related advantages. The maximum rate of coolant loss after an accident is significantly reduced because the largest external pipe connected to the pressure vessel is < 2.8 in. in diameter. Because there are no large primary coolant pipes, a large-break LOCA with rapid loss of reactor vessel water inventory is not possible. Equipment failures that would normally result in a substantial loss of coolant are no longer as significant. For example, a casing or seal failure on a main circulation pump is not a LOCA in the SIR design. Many potential seismic-related failures caused by differential movement of pressure vessel/steam generator equipment are eliminated. The larger pressure vessel also places more distance between the core and vessel wall and thereby reduces the radiation damage to the vessel.

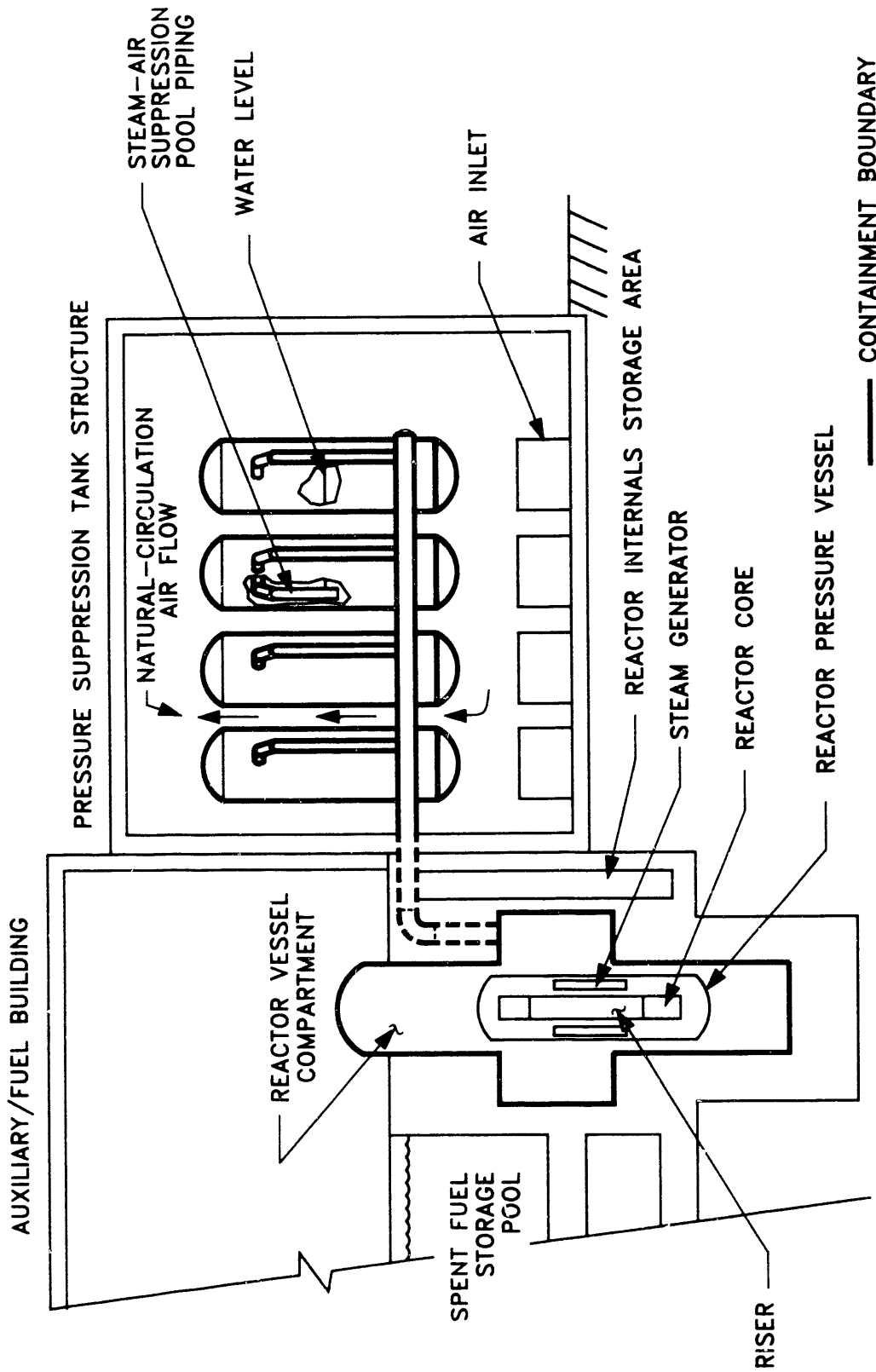

Fig. D.8. Safe integral reactor containment boundary and pressure suppression system.

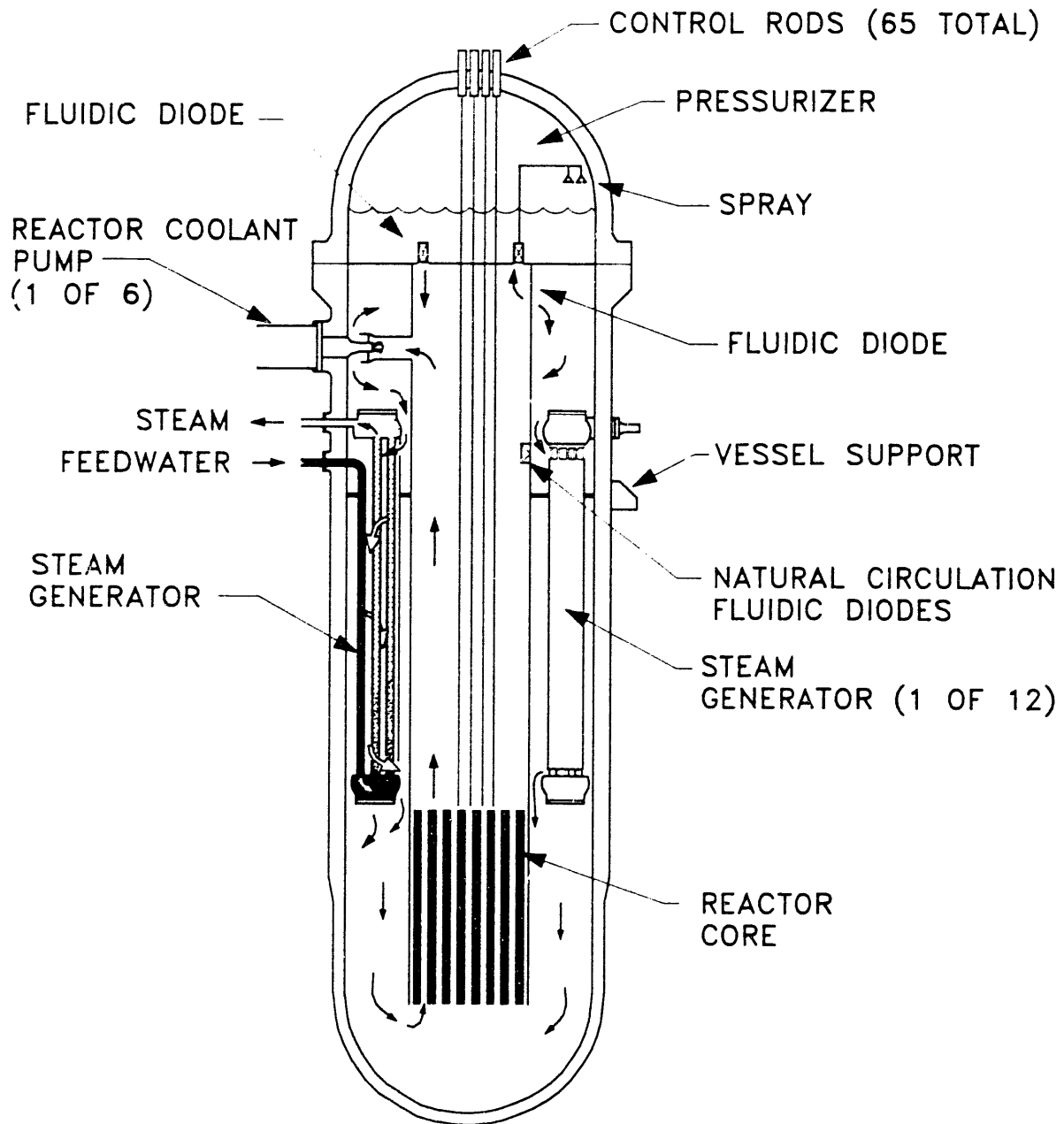

Fig. D.9. Primary circuit flow diagram for safe integral reactor.

Table D.6 Major design parameters of the Safe Integral Reactor

| | |
|----------------------------------|------------------------------|
| <u>Reactor</u> | |
| Thermal power | 1,000 MW(t) |
| Electrical power | 320 MW(e) |
| Coolant inlet/outlet temperature | 295° C/318° C |
| Coolant flow rate | 7,500 kg/s |
| Core outlet pressure | 15.5 MPa |
| Pressure vessel height | 19.2 m |
| Pressure vessel diameter | 5.8 m |
| Pressure vessel weight | ~1,000 tons |
| <u>Core</u> | |
| Fuel/moderator | UO ₂ /light water |
| Fuel enrichment | 3.3 to 4.0% |
| Core power density | 55 kW/L |
| <u>Reactor coolant pumps</u> | |
| Number | 6 |
| Type | Glandless wet winding |
| Operating power | 700 kW |
| <u>Steam generator</u> | |
| Number | 12 |
| Type | Modular once-through |
| Material | Inconel 690 |
| Steam temperature/pressure | 298° C/5.5 MPa |
| Feed water temperature | 224° C |

The upper part of the pressure vessel contains the passive pressurizer system (PPS) that regulates reactor pressure under normal and accident conditions [Forsberg and Weinberg, 1990]. The pressurizer coolant in the upper head of the vessel is separated from the primary circuit coolant by a steel plate. Penetrations exist in the plate for the control rod shrouds and pipes for the pressurizer spray. The use of fluidic diodes, a type of one-way valve with no moving parts, provides a passive means of supplying spray flow. Operation of the PPS is similar to conventional PWR pressurizers except for the use of a passive device to provide the water spray. If primary circuit pressure or water level decrease, the fluidic diodes allow water to leave the pressurizer rapidly as electric heaters generate more steam. If pressure increases, the fluidic diodes prevent large quantities of water from entering at the bottom of the pressurizer but force incoming water into the pressurizer spray lines. This water spray condenses some of the steam and lowers the pressure. In short, water only enters the pressurizer via spray nozzles into the steam volume and only leaves by the fluidic diodes at the bottom of the pressurizer where the coldest liquid water is located.

There are several subsystems associated with the ECCS.

1. For decay heat removal or a small LOCA, the secondary condensing system provides water to the steam generators, which can boiloff steam to the atmosphere while removing reactor decay heat.
2. The emergency coolant injection system uses steam injectors with steam from the reactor to inject water.
3. For larger LOCAs, the safety depressurization system depressurizes the reactor and allows gravity flow of water from storage tanks to the reactor core for cooling.

The PCCS, shown in Fig. D.8, consists of the reactor vessel (RV) compartment, eight cylindrical steel pressure suppression tanks with external fins, and a vent system connecting the RV compartment with the suppression tanks. Each pressure suppression tank operates as a conventional BWR suppression pool and is used to rapidly cool and condense the steam-air mixture from the RV compartment after a LOCA. This is accomplished by bubbling the higher-pressure steam-air mixture through a bath of cool water. Each tank has a finned exterior surface to promote heat transfer to the ambient air. Passive, long-term cooling of the containment is, thus, established. A secondary function is to prevent gaseous and particulate radionuclides from entering the containment atmosphere by scrubbing the steam-air mixture with the tank water.

D.6 REFERENCES

- Andrews, P. J., Hall, S. F., and Gibson, I. H., 1991. "SIR Reactor Safety and Decommissioning," *Journal of the British Nuclear Energy Society*, (April, 1990).
- Anon., 1990. "Vendors Ready to Offer Both Big and Small Advanced PWRs," *Nucleonics Week*, 31(20):1
- Conway, L. E., 1988. Westinghouse Electric Company, "Westinghouse AP600 Passive Safety Systems—Key to a Safer, Simplified PWR," *American Nuclear Society International Topical Meeting—Safety of Next Generation Power Reactors*, Seattle, Washington, May 1-5, 1988.
- Electric Power Research Institute, 1991. *PWR Passive Plant Heat Removal Assessment: Joint EPRI-CRIEPI Advanced LWR Studies*, EPRI NP-7080M.
- Forsberg, C. W., Weinberg, A. M., 1990. "Advanced Reactors, Passive Safety, and Acceptance of Nuclear Energy," *Annual Review of Energy*, 1990, 15:133-152.
- INVAP, 1991. "CAREM Aims to Make Very-Low-Power Reactors Economic," *Nucl. Eng. International*, April 1991, 49-51.
- Kataoka, Y., Suzuki, H., Murase, M., Sumida, I., Horiuchi, T., Mike, M., 1988. "Conceptual Design and Thermal-Hydraulic Characteristics of Natural Circulation Boiling Water Reactors," *Nucl. Technol.*, 82:147-156.
- Matsuoka, T., 1991a. "A Simplified Japanese PWR," *Nucl. Eng. Int.*, 36(443):47.
- Matsuoka, T., 1991b. Personal correspondence between Tsuyoshi Matsuoka, Mitsubishi Heavy Industries, Inc., and Dr. C. W. Forsberg, Oak Ridge National Laboratory, July 2, 1991.
- NEA, 1991. Small and Medium Nuclear Reactors: What Prospects?, (In preparation), Organization for Economic Cooperation and Development/Nuclear Energy Agency.
- NRC, 1987. Wolfe, B., Wilkins, D. R., "Future Directions in Boiling Water Reactor Design," *Fifteenth Water Reactor Safety Information Meeting*, Gaithersburg, Maryland, October 26-29, U.S. Nuclear Regulatory Commission, NUREG/CP-0091, Vol. 1, 1987.
- Oka, Yoshiaki, 1989. "Research and Development of Next Generation Light Water Reactors in Japan," *International Atomic Energy Agency Technical Committee Meeting on Passive Safety Features in Current and Future Water-Cooled Reactors*, Moscow, USSR, March 21-24, 1989.
- Tower, S. N., Schulz, T. L., Vijuk, R. P., 1988. "Passive and Simplified System Features for the Advanced Westinghouse 600 MW(e) PWR," *Nuclear Engineering and Design*, 109, 147-154.

END

**DATE
FILMED**

01 / 17 / 92
