

117
8/11/81
M.E.

①

MASTER DR-2932

06373

LBL-12383
UC-20



Lawrence Berkeley Laboratory

UNIVERSITY OF CALIFORNIA

Accelerator & Fusion Research Division

A CONCEPTUAL DESIGN FOR THE ZEPHYR NEUTRAL-
BEAM INJECTION SYSTEM

W.S. Cooper, V.P. Elischer, D.A. Goldberg,
D.B. Hopkins, V.L. Jacobson, K.H. Lou, and
J.T. Tanabe

March 1981

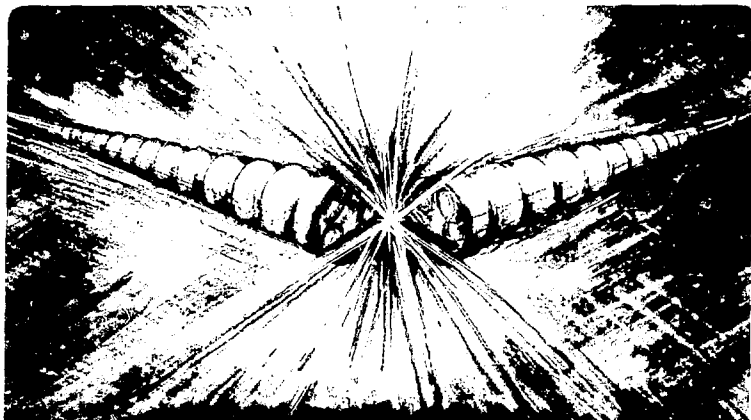

Prepared for the U.S. Department of Energy under Contract W-7405-ENG-48

A CONCEPTUAL DESIGN FOR THE ZEPHYR NEUTRAL-BEAM INJECTION SYSTEM*

W. S. Cooper, V. P. Elischer, D. A. Goldberg, D. B. Hopkins,
V. L. Jacobson, K. H. Lou, J. T. Tanabe

Lawrence Berkeley Laboratory
University of California
Berkeley, California 94720 USA

DISCLAIMER



March, 1981

- * This work was supported by the Director, Office of Energy Research, Office of Fusion Energy, Development and Technology Division, of the U.S. Department of Energy under Contract No. W-7405-ENG-48.

ABSTRACT

In June, 1980, the Lawrence Berkeley Laboratory (LBL)* began a conceptual design study for a neutral beam injection system for the ZEPHYR ignition tokamak proposed by the Max-Planck-Institut für Plasmaphysik in Garching, Germany. The ZEPHYR project was cancelled, and the LBL design effort concluded prematurely in January, 1981. This report describes the conceptual design as it existed at that time, and gives brief consideration to a schedule, but does not deal with costs.

In our design effort we were able to draw heavily on our experience in constructing and operating the TFTR prototype beamline at LBL. ZEPHYR requirements were similar to those of TFTR in many ways, but exceeded existing capability in the areas of

- 1) beam energy (160 keV vs 120 keV),
- 2) remote maintenance, and
- 3) system reliability.

The conceptual design for ZEPHYR is similar to that of TFTR, but is simplified both mechanically and electrically. The mechanical design is specifically configured for ease of remote maintenance: Direct vertical access for cranes and remote manipulators is provided for all critical components, which can be individually removed without disturbing other components. A new reflection magnet design permits the use of simple thermal-inertia dumps for the 1.5 sec beam pulses. Most of the water cooling lines are outside the vacuum envelope. Fifty square meters of cryopump area are available, if needed. The high voltage power supply is a simple, unregulated design, controlled by solid-state equipment

*A full list of abbreviations and acronyms used in this report is given in Appendix B.

located near ground potential in the ac primary circuit; the design uses commercially available components, and is consistent with standard industrial practice.

It appeared unlikely that the original desired date for neutral injection on ZEPHYR (Spring, 1987) could be met. The delay would be caused mainly by the additional time needed to perfect remote handling capability and to attain the high system reliability required.

A significant conclusion of this study is that a systems analysis and design effort should continue as an ongoing effort at the neutral beam laboratories to enable them to respond more quickly to new neutral beam injection requirements of confinement experiments, to reduce the time required to develop and deliver future neutral beam injection systems, and to develop and incorporate cost-reducing innovations where possible.

ACKNOWLEDGEMENTS

Many persons at LBL who were not members of the design team participated significantly in this study. In particular we would like to acknowledge the valuable contributions of the following people.

O. A. Anderson	Reflection Magnet Design
W. R. Baker	Power Supply Conceptual Design
C. F. Chan	Accelerator Ion Optics
J. H. Feist*	General System Comments
J. V. Franck	Power Supply Conceptual Design
K. Halbach	Magnetic and Vacuum Analysis
G. P. Harnett	Power Density on Ion Dump
L. T. Jackson	Power Supply Modeling
H. Kim	Eddy Current Analysis
H. M. Owen	Power Supply Conceptual Design
L. Soroka	Power Density on Ion Dump

The report also benefitted from critical reading by our colleagues in the LBL Magnetic Fusion Energy group.

* Permanent Address: Max-Planck-Institut für Plasmaphysik, Garching, Germany

This work was supported by the Director, Office of Energy Research, Office of Fusion Energy, Development and Technology Division, of the U.S. Department of Energy under Contract No. W-7405-ENG-48.

CONTENTS

	Page
Abstract	iii
Acknowledgements	v
List of Figures	xi
List of Tables	xiii

1. OVERVIEW

1.1 Introduction	1
1.1.1 Historical Background	1
1.1.2 Design Approach	4
1.2 Status of Conceptual Design	6
1.2.1 General Status at the End of the Project	6
1.2.2 Technical Status	6
1.2.2.1 Mechanical	6
1.2.2.2 Electrical	8
1.2.2.3 Controls and Diagnostics	9
1.2.3 Schedule Status	11
1.2.4 Cost Status	13
1.2.5 Remaining Technical Questions	13
1.2.5.1 Questions to be Resolved Before Completion of Conceptual Design	15
1.2.5.2 Questions to be Resolved Before Completion of The Project	15
1.2.5.3 Supporting Research and Development	16
1.3 Summary	16
References to Chapter 1	18

2. NEUTRAL BEAMLINE

2.0 System Overview	19
2.0.1 Beamline Configuration	19
2.0.1.1 Working Specifications	20
2.0.1.2 Magnetic Shielding	23
2.0.1.3 Remote Handling	27
2.0.1.4 Source Layout	28
2.0.2 Anticipated Performance	30
2.1 Mechanical Configuration	32
2.1.1 Overall Beamline	32
2.1.2 Torus Penetration and Duct	38
2.1.3 Vacuum Vessel and Carriage	38
2.1.4 Source, Snubber, and Housing	41
2.2 Subsystem Performance Characteristics and Details	42
2.2.1 Ion Source	42
2.2.2 Accelerator System	43

2.2.2.1	Insulator Structure	43
2.2.2.2	Stored Energy	43
2.2.2.3	Electrode Design	45
2.2.3	Neutralizer	
2.2.4	Ion Removal System	48
2.2.4.1	Beam Optics	49
2.2.4.2	Analyzing Magnet	51
2.2.4.3	Beam Dump	52
2.2.5	Calorimeter	54
2.2.6	Vacuum and Cryogenic Systems	56
2.2.6.1	Cryopumping Performance	57
2.2.6.2	Cryopanel Configuration	60
2.2.6.3	Cryopanel Construction	61
2.2.6.4	Cryogenic Circuitry	65
2.2.7	Miscellaneous Auxiliary Systems	65
2.2.7.1	Water	65
2.2.7.2	Rough Vacuum	67
2.2.7.3	Pump and Purge	67
2.2.7.4	Liquid Helium Refrigerator	67
2.2.7.5	Liquid Nitrogen System	67

3. POWER SUPPLIES

3.0	Introduction	69
3.0.1	Design Philosophy	69
3.0.2	LBL Experience	70
3.0.3	General Description	72
3.1	Design Specifications	76
3.1.1	ZEPHYR Requirements	76
3.1.2	Proposed Neutral Beam Power System Specifications	76
3.2	Primary Power Sources and Loading	82
3.2.1	Source and Feeder Arrangement	82
3.2.2	Load and Power Factor Summary	84
3.2.3	Motor Generator Considerations	84
3.3	Accel/Gradient Grid Power Supply	87
3.3.1	Introduction	87
3.3.2	General Description and Block Diagram	89
3.4	Auxiliary Power Supplies	94
3.4.1	Filament Power Supplies	94
3.4.2	Arc Power Supply	95
3.4.3	Suppressor Power Supply	95
3.4.4	Magnet Power Supply	96
3.5	Core Snubber	97
3.5.1	General	97
3.5.2	Stored-Energy Analysis	99

4. CONTROL AND DIAGNOSTIC SYSTEMS

4.0	General Requirements	101
4.1	Control System Architecture	102
4.2	Instrumentation	105
4.2.1	Thermocouples	105
4.2.2	Water Flow Calorimetry	107
4.2.3	Cryosystem Indicators	107
4.2.4	Electrical Signals	108
4.2.5	Fault Detectors	109
4.2.6	Safety Interlocks	109
4.3	Interface Hardware	109
4.3.1	Thermocouples	110
4.3.2	Cryosystem Indicators	110
4.3.3	Electrical Signals	110
4.3.4	Safety Interlocks	111
4.3.5	Sequencing and Timing Signals	111
4.3.6	Other Commercial Interface Hardware	112
4.3.7	Non-Commercial Interface Hardware	112
4.4	Computer	112
4.5	Operator Interface	114
4.6	ZEPHYR Controls	118
4.7	Software Architecture	119
	References to Chapter 4	123
Appendix A	ZEPHYR Interface Control Document (ICD)	A-1
Appendix B	List of Abbreviations and Acronyms Used	B-1
Appendix C	Detailed Description of Accel Power Supply Operation	C-1

LIST OF FIGURES

Page

Fig. 1.2.2-1	Conceptual design of a ZEPHYR beamline	7
Fig. 1.2.2-2	Simplified schematic diagram of accel power supply	10
Fig. 1.2.3-1	NBSTF experience and TFTR schedule	12
Fig. 1.2.3-2	Plausible ZEPHYR beamline schedule	14
Fig. 2.0.1-1	Time dependence of the current in the ZEPHYR vertical field coils	24
Fig. 2.0.1-2	160 keV D ⁺ ion trajectories	26
Fig. 2.1.1-1	Floor plan of ZEPHYR experimental hall showing tokamak and six neutral beamlines.	33
Fig. 2.1.1-2	Plan view of neutral beamline	34
Fig. 2.1.1-3	Elevation view of neutral beamline	35
Fig. 2.1.1-4	Exploded view of neutral beamline showing principal components	37
Fig. 2.2.1-1	Bucket source and accelerator for TFTR	44
Fig. 2.2.2-1	Ion trajectories through a ZEPHYR accelerator structure calculated using the code "WOLF"	46
Fig. 2.2.4-1	Beam optics for ion-removal system	50
Fig. 2.2.6-1	Pressure distribution along beamline	58
Fig. 2.2.6-2	Pressure line-integral calculated from duct entrance	59
Fig. 2.2.6-3	4.2 K helium-cooled cryopanel surface	62
Fig. 2.2.6-4	77 K liquid-nitrogen-cooled chevron shields	63
Fig. 2.2.6-5	Cryopanel support system	64
Fig. 2.2.6-6	Liquid helium distribution system	66
Fig. 3.0.3-1	Electrical systems block diagram	73
Fig. 3.2.1-1	Primary power source and distribution	83

Fig. 3.2.3-1	Generator loading and output frequency	86
Fig. 3.3.2-1	Accel power supply block diagram	90
Fig. 3.3.2-2	Starting transients and magnetics	93
Fig. 3.5.1-1	Core snubber circuit and assembly	98
Fig. 4.1-1	Neutral beam controls and diagnostics	103
Fig. 4.1-2	Block diagram of beamline computer system	106
Fig. 4.5-1	A typical touch-panel control display	115
Fig. 4.5-2	A typical touch-panel "menu" of diagnostic displays	116
Fig. C-1	Simplified schematic diagram of accel power supply	C-2

LIST OF TABLES

		Page
Table 1.1.1-1	ZEPHYR Neutral Injection Beam Requirements	1
Table 1.1.1-2	ZEPHYR Neutral Beam Injection System Requirements	2
Table 2.0.1-1	ZEPHYR Beamline Working Specifications	20
Table 2.0.1-2	Range of Injection Angles	29
Table 2.0.2-1	Anticipated Performance	31
Table 2.2.6-1	Cryogen Requirements for ZEPHYR Beamline	60
Table 3.0.2-1	LBL NB Power System Milestones	71
Table 3.0.3-1	Approximate Typical Operating Sequence (Including Sparkdown)	75
Table 3.1 1-1	ZEPHYR Requirements and Constraints	77
Table 3.1.2-1	NB Power System Specifications	78
Table 3.2.2-1	Primary Loading and Power Factor Summary	85
Table 3.5.2-1	"Unsnubbed" Stored-Energy Summary	100

1. OVERVIEW

1.1 Introduction

1.1.1 Historical Background

In January, 1979, the Max-Planck-Institut für Plasmaphysik (IPP), Garching, Federal Republic of Germany, proposed a major new tokamak confinement experiment called ZEPHYR.¹ ZEPHYR is a German acronym standing for Zünd-Experiment für die Physik im Reaktor, or Ignition Experiment for Reactor Physics. The purposes of the proposed experiment were:

1. to investigate α -particle heating,
2. to ignite a DT plasma,
3. to keep the DT plasma burning for many energy confinement times, and
4. to investigate a tolerable shut-down procedure.

U.S. involvement in ZEPHYR was solicited by IPP in several areas, including neutral beam injection, which was chosen by IPP as the primary heating mechanism. The ZEPHYR neutral injection requirements are summarized in the following table.

Table 1.1.1-1

ZEPHYR Neutral Injection Beam Requirements

Beam Energy	160 keV
Gas	D ₂
Pulse Length	1.5 sec
Neutral Power into Plasma	15 MW of 160 keV D ₀ 25 MW of all energies

A summary of some of the most important ZEPHYR neutral beam injection system (NBIS) requirements is given in Table 1.1.1-2. In most cases these requirements significantly exceed current capabilities (as typified, for example, by the TFTR injection system).

Table 1.1.1-2

ZEPHYR Neutral Beam Injection System Requirements

Number of beamlines	≤ 6
Reliability	> 75% of shots to give ≥ 25 MW to plasma
Duty Factor	$\geq 1.25\%$
Availability	> 80%
Maintenance	By remote means
Minimum maintenance interval	10^3 plasma shots
Lifetime	> 2×10^5 beam pulses for all components except source filaments
Tritium purging	Beamline bakeable to 150°C
Modularity	All critical components separately and independently replaceable
Radiation exposure	10^9 rads (neutron and gamma)
Principal power source	Motor-generator set
Beamline materials	Chosen for low activation

An informal workshop on ZEPHYR neutral injection was held at the Lawrence Berkeley Laboratory (LBL), February 4-8, 1980; one of the conclusions of this workshop was that ZEPHYR requirements seemed to be

possible from the standpoint of both technology and physics. Just as the ZEPHYR experiment itself was complementary to the U.S. program, which did not include a similar experiment, the ZEPHYR neutral injection systems seemed to fit reasonably well into the U.S. neutral beam program. The requirements were similar to those already being considered in the energy range 150-175 keV (ETF, INTOR), except for the somewhat shorter beam pulse length. The shorter ZEPHYR construction schedule (at the time of the LBL workshop, neutral injection on ZEPHYR was scheduled for the Spring of 1987) would force an early look at such difficult problems as remote maintenance capability, which does not exist in any beamlines now in use.

In June of 1980 the Office of Fusion Energy, Development and Technology Division of the U.S. Department of Energy (DOE), funded groups at both LBL and the Oak Ridge National Laboratory (ORNL) to undertake competitive conceptual design efforts, to be concluded by September, 1981. The goals of these efforts were stated as follows:²

"This Neutral Beam Conceptual Design is to be of sufficient detail to give confidence in schedule, design feasibility and cost to allow finalization of a formal agreement between the U.S. and the FRG. It must also be adequate to allow you to make a formal proposal for the remainder of the ZEPHYR neutral beam work, up through delivery of the neutral beam sets."

Design work began at both laboratories, and in a three-way effort involving LBL, ORNL, and IPP, work started also on an Interface Control Document (ICD) to define the interfaces with ZEPHYR systems and the

performance requirements of the NBIS. This in itself was a valuable exercise (a draft version of the ZEPHYR ICD is included as Appendix A to this report). A meeting between LBL, ORNL, IPP, DOE, and other interested parties was held at ORNL in November 1980, to try to complete the ICD. Early the next month, December 1980, we learned that the Federal Republic of Germany was unable to fund ZEPHYR, and that IPP had cancelled the project. Shortly therefore, the U.S. ZEPHYR effort stopped also.

Design work was well along by this time at LBL, although work had only just begun on the cost and schedule aspects of the problem. We decided to report our efforts in the form of a study stressing the technical aspects of the conceptual design, but with little consideration given in the report to costs or schedules (although these constraints were, of course, constantly in mind during the design process). The result is this report.

1.1.2 Design Approach

We decided that the ZEPHYR injection requirements could best be met by an upgraded and improved version of the TFTR beamline, coupled with a new and very simple power supply design tailored to the ZEPHYR motor-generator set (a ZEPHYR requirement). The Neutral Beam System Test Facility (NBSTF) at LBL, which is the prototype TFTR beamline, was designed as a joint LBL/LLNL activity, and has been operating at LBL since June, 1979. This is a 120 keV system, as opposed to ZEPHYR's 160 keV, but has the same pulse length (1.5 sec), and is of approximately the same size. We would therefore be able to examine

actual construction costs and operating experience for a system very similar to that which we would propose for ZEPHYR, and simplify and improve the design based on this experience. This approach would afford the best chance to meet the extremely aggressive ZEPHYR startup schedule and the demanding technical challenges, especially those of remote maintenance capability and reliability.

These thoughts led to the following guidelines for the technical design of the ZEPHYR NBIS:

1. The design would be based on the TFTR design, simplified, reduced in costs, and improved wherever possible.
2. Existing industrial components would be used wherever possible.
3. To gain in system reliability and remote maintenance capability, we would move as many vulnerable beamline components as possible outside the vacuum system, and provide direct vertical access to them by cranes and remote handling equipment; we would also make it possible to remove any of the critical components (individual cryopanel, dumps, ion deflection magnets, source assemblies, etc.) without disturbing the others.
4. The design should require minimum extrapolation from existing technology, in order to maximize reliability and minimize design and construction time and costs.

It was our intention to involve industry as soon as possible in the project, to benefit from industrial design and manufacturing experience, and to maximize transfer of technology to industry, but funding limitations prevented us from doing this.

1.2 Summary of the Conceptual Design

1.2.1 General Status at the End of the Project

At the end of the design effort we had reached the point where we had examined all major sub-systems and had found conceptual designs for all of them that satisfied both our internal guidelines and the ZEPHYR requirements (set forth in the ZEPHYR ICD, Appendix A). In particular, it appeared that no unreasonable extrapolation would be required from existing experience and technology (NBSTF) except in the areas of remote maintenance and reliability. However, only a few preliminary optimization studies to minimize costs had been performed, and practically no cost information was available. It was apparent that the entire NBIS should go through a prototype stage to verify the validity of the design of simple but nevertheless expensive sub-systems, such as the high voltage power system, to develop and test techniques for remote maintenance on the beamline, and to perfect and demonstrate reliable operation of the entire system.

1.2.2 Technical Status

1.2.2.1 Mechanical

An elevation view of the LBL conceptual design for a ZEPHYR beamline is shown in Fig. 1.2.2-1. Mechanical highlights of the conceptual design may be summarized as follows:

1. All critical components--all cryopanel, the ion and neutral dumps, the magnet, and the three source assemblies--are directly and independently accessible by overhead crane and remote handling equipment. Each item can be removed independently of the others.

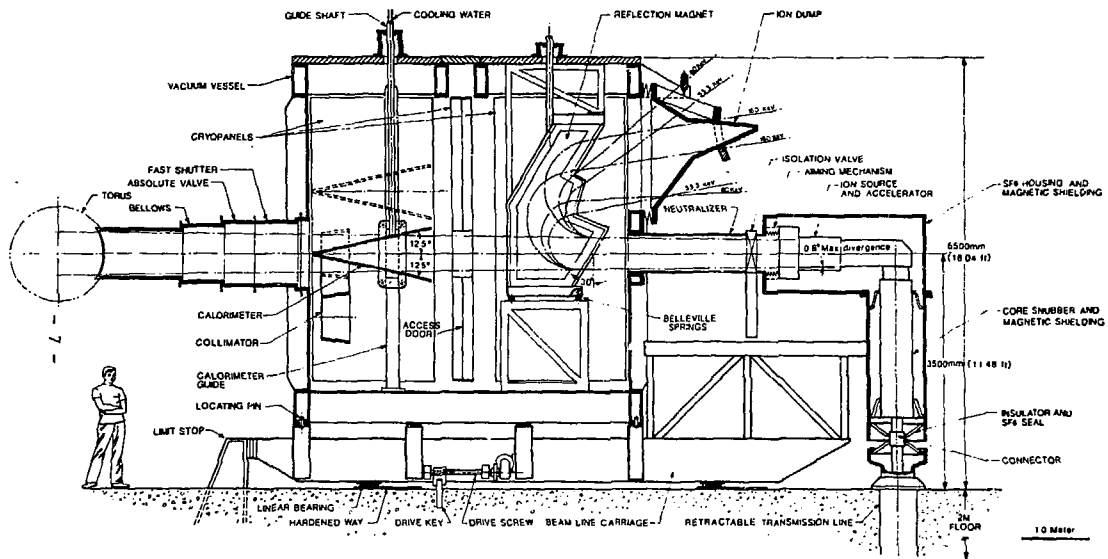

NBL 813-8482

2. Water cooling lines for the ion dump and the neutralizer are outside the vacuum envelope.
3. Both the ion and neutral dumps are single, simple "Vees" of copper. The designs are inertial (not actively cooled), and are conservative for 1.5 sec pulse operation.
4. The ion sweep magnet is of a new reflection type that defocuses the ion beam to reduce the power density on the ion dump, and does not require water cooling.
5. An aluminum alloy was found for the vacuum vessel that had several highly desirable properties. It contained only a very small concentration of trace elements that produced long-lived isotopes after neutron irradiation (Mn was the worst offender), it was weldable without subsequent heat-treatment, and it was readily available.
6. A mounting system was devised whereby beamlines could be removed and replaced without requiring alignment adjustments to be performed in the radioactive environment.
7. The design permits installation of up to 50 m^2 of cryopumping, if necessary (the TFTR beamline has 30 m^2).
8. A cryopanel design was chosen to permit bake-out to 150°C for tritium removal, but yet did not require bellows in the vacuum to accommodate thermal expansion.

1.2.2.2 Electrical

Highlights of the conceptual design may be summarized as follows:

1. All power supplies (PS) use solid-state circuitry exclusively, with the exception of ignitrons in the accelerating (accel) PS crowbar circuit, and the tetrode switch tube in the suppressor PS.
2. Control of the accel PS is done using solid-state switching in the primary circuit, thereby eliminating all control circuitry from the high-voltage secondary (see Fig. 1.2.2-2).
3. The accel PS has the ability to turn off and restart several times (if necessary) during a single beam shot, in the event of a spark-down in the accelerating grid structure. The current in the primary circuit exhibits negligible increase during spark-down and recovery.
4. The turn-on of the accel PS is phase-synchronized relative to its last turn-off, thereby eliminating unbalanced transformer saturation and the resulting undesirable transient behavior in the dc secondary.
5. Electrically symmetric extended-delta windings are used in the accel PS transformer to minimize high voltage ripple.
6. The ion source filament PS is "stepped" in order to reduce overheating due to additional power from the arc current.
7. All major power supply components are well within present industrial fabrication capability.

1.2.2.3 Controls and Diagnostics

Virtually all the control and diagnostic hardware and software necessary for the ZEPHYR NBIS either has been developed already at LBL or is being developed for NBSTF and its upgrade, NBETF.³

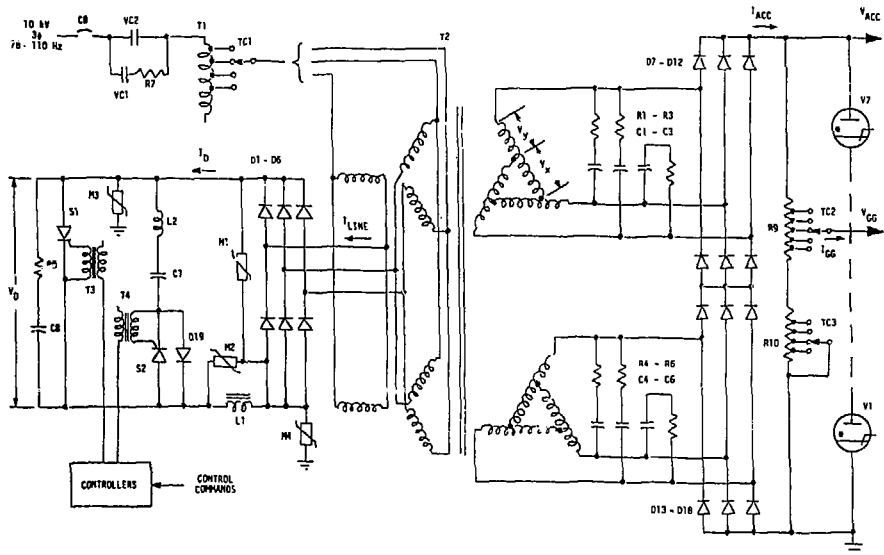

XBL 814-9191

Fig. 1.2.2-2 Simplified schematic diagram of accel power supply

Better yet, this control system has been in use for some time, and will be extensively tested during this Fiscal Year. A substantial saving in costs and time would be realized by using this investment also for ZEPHYR.

1.2.3 Schedule Status

Development of a realistic schedule would have come later in the design study, after the conceptual design was frozen. It was apparent, however, that the reliability and remote maintenance requirements would introduce large uncertainties in the schedule, and necessitate the development of a prototype. The schedule would be complicated by the requisite three-way LBL-IPP-DOE interaction (assuming LBL were chosen to carry on with the detailed design), and by the governmental agreements required. It was also apparent that, although massive industrial involvement and coordination of the entire project was the most desirable way to transfer neutral beam technology to industry, it probably would not produce beamlines on the shortest time scale or at the lowest cost. These issues were not resolved.

We can use our NBSTF and TFTR experience as a guide in estimating development and construction times for the ZEPHYR NBIS. Figure 1.2.3-1 summarizes this experience. LBL began consideration of a conceptual design for TFTR neutral beam systems in April, 1975, and completed the conceptual design⁴ in August of that year. The LBL Proposal⁵ was accepted by the Princeton Plasma Physics Laboratory (PPPL) in January 1977, and work began immediately, aimed at operation of neutral injectors on TFTR in June of 1982. If this schedule is met, the following time intervals will have elapsed between the major milestones given below and the start of operation on TFTR:

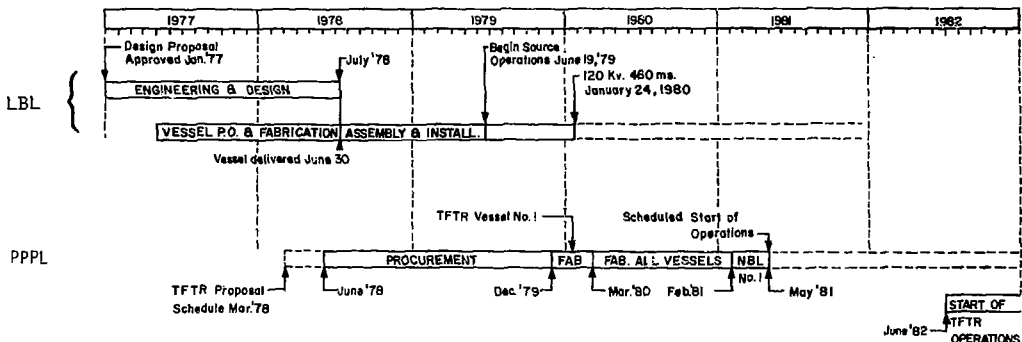

Fig. 1.2.3-1 NBSTF experience and TFTR schedule

LBL 814-9353

From beginning of conceptual design - 7 years

From beginning of detailed design and construction - 5-1/2 years

Preliminary scheduling studies and our NBSTF and TFTR experience led us to propose the tentative but plausible ZEPHYR Beamline Schedule shown in Fig. 1.2.3-2. This schedule shows neutral beam operation on ZEPHYR beginning a year later than desired by IPP, and we considered even this schedule to be aggressive and optimistic.

The design project, had it been completed, would have produced a schedule which, even had it not differed significantly from that in Fig. 1.2.3-2, would have been more credible. The areas of major uncertainty in the currently proposed schedule are:

1. the time required to perfect remote maintenance capability,
2. the time required to perfect and demonstrate reliability, and
3. the degree of industrial involvement.

1.2.4 Cost Status

Although cost constraints were constantly kept in mind in the conceptual design phase, trade-off studies for cost minimization would only have been performed in the latter half of the project, along with schedule studies. We did not reach this stage; therefore, no cost information will be given. The largest uncertainty in estimating costs was in the area of remote handling.

1.2.5 Remaining Technical Questions

In a number of technical areas, we have identified problems that need to be carefully studied at the appropriate point in the course of the project, and also areas in which supporting research and development is required. We summarize these problem areas below:

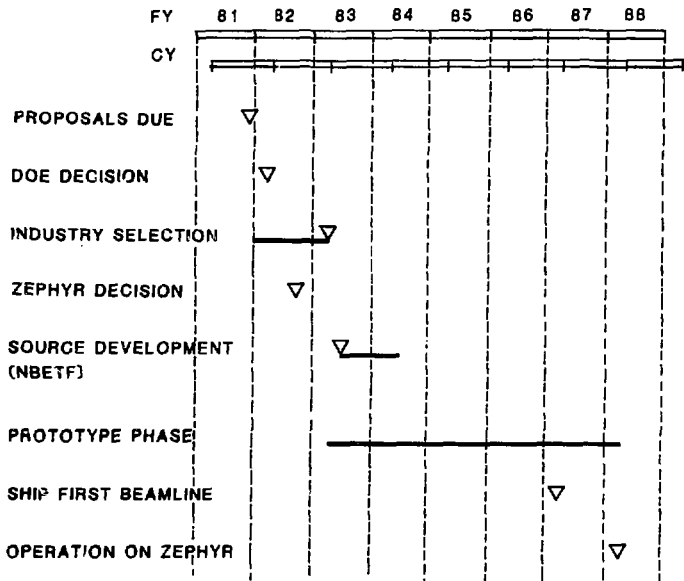

XBL 814-9250

Fig. 1.2.3-2 Plausible ZEPHYR beamline schedule

1.2.5.1 Questions to be Resolved Before Completion of
Conceptual Design

1. Complete computer code development now underway, specifically for better calculation of power densities on the ion dump.
2. Study thermal stress and fatigue of the ion dump and calorimeter.
3. Study cryopanel heating due to eddy currents and neutrons.
4. Apply NBSTF cryopump experience and measured performance to ZEPHYR design.
5. Complete cost study of NBSTF construction.

1.2.5.2 Questions to be Resolved Before Completion of the
Project

1. Model field penetration into the vacuum tank and calculate ion trajectories.
2. Model the ion deflection magnet and measure the fields at the exit face.
3. Model a cryopanel.
4. Model the source-snubber-transmission line to check high voltage breakdown.
5. Model the high voltage power supply at higher voltage and power levels, and perform computer studies of the supply.
6. Develop additional design codes as needed.
7. Analyze NBSTF operation for reliability.
8. Construct and operate a ZEPHYR NBIS prototype to
 - a) demonstrate and improve system reliability, and
 - b) demonstrate and improve remote maintenance capability.

1.2.5.3 Supporting Research and Development

1. Develop an ion source with a long-lived cathode and/or remote maintenance capability.
2. Improve the D^+ fraction of the ion source.
3. Develop water-cooled grid technology for back-up accelerator design.
4. Demonstrate 160 keV, 1.5 sec source operation with beam.
5. Demonstrate 160 keV, 1.5 sec source operation with unregulated high voltage.
6. Study sparking and degradation of the voltage-holding ability of the source at 160 keV ("stored energy" problem).
7. Compare NBSTF system performance with that predicted by the design codes used; improve design codes where necessary.

1.3 Summary

Although this project did not continue to completion, we were able to draw a number of conclusions from our work to date, and we list them below. Some of these relate specifically to the ZEPHYR design; other are more general in nature. While the present report is not the appropriate place to document the latter in any detail, the issues they dealt with seemed to be of sufficient moment that we felt obliged to raise them, if only in summary form.

1. It appeared that a ZEPHYR NBIS could be designed and built using what were, for the most part, reasonable extrapolations from existing technology. A major exception was the area of remote-handling capability, which would likely require substantial additional development.

2. It appeared unlikely that the ZEPHYR NBIS could be delivered in time to meet the proposed ZEPHYR start-up date of spring, 1987. The uncertainty was mainly due to the unknown difficulty in achieving high reliability and remote maintenance capability, and the unknown degree of industrial involvement.
3. Construction of a prototype beamline and associated power supplies was regarded as virtually essential for a number of reasons, despite its apparent negative impact on the NBIS delivery schedule. The remote handling features constitute a sufficiently major innovation that their development on a prototype system is required. An equally compelling argument, in our view, is that the amount of power in an NBIS is so large that even a small unaccounted for fraction of stray beam or electrical power is capable of doing considerable damage; to achieve reliable operation, such situations must be identified and corrected, and this is by far most efficiently done in the prototype stage. In short, we feel that system reliability could only be guaranteed after extensive testing and appropriate modification of a prototypical NBIS.
4. Industrial involvement, if it is eventually to be substantial (for example, having an industrial systems integrator manage the detailed design, construction, and testing), should occur at an early stage in the project. Such participation raised a number of logistical questions which we were unable to address fully. The process of selecting an industrial partner would probably take over one year. To maximize his degree of participation it would be necessary to delay much of the

detailed design work, which would not only impact negatively on the final delivery schedule, but would make it difficult to maintain interim support for the in-house (LBL) design team (see also 5, below); on the other hand, proceeding with the design work prior to selection, in order to minimize delay and maintain continuity, would compromise the early introduction and development of industrial expertise.

5. Laboratories involved in NB development need to maintain an on-going program of system design studies. Notwithstanding the large number of highly competent individuals at such laboratories, design teams can not be assembled and/or educated on short notice, nor can design tools be developed or resurrected quickly. In addition, ongoing programs in research and development are needed to come up with and incorporate cost-reducing innovations wherever possible. In summary, continuity is essential in the engineering and systems aspects of the program, as well as in the research and development areas.

References

1. ZEPHYR, Proposal for a Compact Ignition Experiment, IPP Study Group, January 1979, revised June 1979.
2. Letter from F. E. Coffman (DOE) to R. R. Borchers (LLNL), April 1980.
3. Proposal to Upgrade the Neutral Beam System Test Facility (NBSTF) to a 170 keV, 65 A, 30 second, 10% Duty Factor Neutral Beam Engineering Test Facility (NBETF), LBL Staff, LBL-5038, Rev. 1, October 1980.
4. TFTR Neutral Beam Injection System Conceptual Design, LBL/LLL CTR Staff, LBL-3296, August 29, 1975.
5. LBL TFTR Neutral Beam System Proposal, December 14, 1976.

2. NEUTRAL BEAMLINE

2.0 System Overview

In the following sections we discuss the thinking that led to the final beamline mechanical configuration, and summarize the anticipated performance of the ZEPHYR NBIS. Fixing the beamline configuration required consideration of ZEPHYR beam acceptance criteria (spatial and angular constraints), magnetic effects (especially the effects of ZEPHYR magnetic fields on ion trajectories in the beamline), suitability of the configuration for remote maintenance, and source module dimensions.

After neutralization, about two-thirds of the beam power remains in the form of positive ions. It is a major problem to dispose of this power safely. We chose to avoid the approach of recovering the ion beam power electrically ("Direct Recovery"), because of the very short time available to perfect this advanced technology. We could not be certain that this approach would work, and if it did, what impact it would have on system costs. We chose instead to use a conventional sweep magnet to separate the ions from the neutrals, and to try to configure the system so that we could use the cheapest possible dump design.

2.0.1. Beamline Configuration

2.0.1.1 Working Specifications

Early in the project, we generated a table of "Working Specifications", reproduced below as Table 2.0.1-1. This table was intended to include all important specifications that could influence the initial mechanical and electrical conceptual designs. The

Table 2.0.1-i

ZEPHYR BEAMLINE WORKING SPECIFICATIONS

I. BEAM

Cross-section at source	10x40 cm
Orientation (40-cm dimension)	Vertical
Angle between beams	5.20°
Current (D ₂ operation)	50 A
Energy	160 keV
Pulse length	1.5 sec
Compostion	
Percent D ⁺	80%
Percent D ₂ ⁺	15%
Percent D ₃ ⁺	5%
Divergences	
1/e Angular half-width perpendicular to rails	0.8° min 1.6° max
1/e Angular half-width parallel to rails	0.25° min 0.50° max

Table 2.0.1-1 (Cont'd)

Typical Beam Powers

(After Traversing Neutralizer $\Pi = 1.2 \times 10^{16} \text{ cm}^{-2}$)

Positive Ion Power

160 keV D ⁺	4754 kW
160 keV D ₂ ⁺	29 kW
160 keV D ₃ ⁺	0.2 kW
106.7 keV D ₂ ⁺	9 kW
80 keV D ⁺	436 kW
53.8 keV D ⁺	<u>92 kW</u>

Total	5320 kW
-------	---------

Negative Ion Power

160 keV D ⁻	10 kW
80 keV D ⁻	10 kW
53.3 keV D ⁻	<u>6 kW</u>

Total	26 kW
-------	-------

Neutral Power

160 keV D ⁰	1637 kW
160 keV D ₂	27 kW
106.7 keV D ₂	16 kW
80 keV D ⁰	700 kW
53.3 keV D ⁰	<u>277 kW</u>

Total	<u>2656 kW</u>
-------	----------------

Total Beam Power (I X V = 8000 kW)	8002 kW
------------------------------------	---------

Table 2.0.1-1 (cont'd)

II. SOURCE

Envelope (Source dimensions without shielding)

Width	53 cm
Height	102 cm
Length	91 cm
Minimum center-to-center spacing	88 cm
Number of filaments	30
Filament current per filament	120 A
total	3600 A
Filament voltage	10 V
Arc current	1200 A
Arc voltage	80 V
Minimum D ₂ gas flow	8 Torr-l/sec

III. NEUTRALIZER

Total length, from grids to end of neutralizer	2.5 m
Cross section	15 x 60 cm
Minimum gas flow out of neutralizer (D ₂)	10 Torr-l/sec
Maximum gas flow out of neutralizer (D ₂)	20 Torr-l/sec

data were derived from calculations and from reasonable extrapolations of TFTR (NBSTF) and Doublet-III beamline experience, and, of course, from ZEPHYR requirements. The data were sufficient to permit examination of beam layouts, power densities on dumps and scrapers, pumping requirements, vacuum tank dimensions, and power supplies. These working specifications were updated as the design progressed and served the useful function of permitting close coordination of different design activities.

2.0.1.2 Magnetic Shielding

The major component of the ZEPHYR magnetic field in the vicinity of the beamlines is vertical, and is due to the vertical field coils. The spatial dependence is very closely approximated by a dipole field distribution (see Fig. 3.6.3, Appendix A). From this, and the time-dependence of the current in the vertical field coils, shown in Fig. 2.0.1.-1, we made an analytical study of the time-dependent magnetic fields in the beamline (including the fields due to induced eddy currents) and of their effect on ion trajectories in the beamline.

The assumptions were:

1. The vacuum vessel was made of aluminum, 4 cm thick.
2. The vacuum vessel was 3 m wide, 5 m long, and 4 m high, with the far end of the box 10 m from the center of the torus.

The conclusions of this approximate analysis were:

1. The time constant for field penetration into the vacuum vessel was given by the L/R time constant of the system and was about 0.7 sec. Therefore, the effects of eddy current fields would be very important.

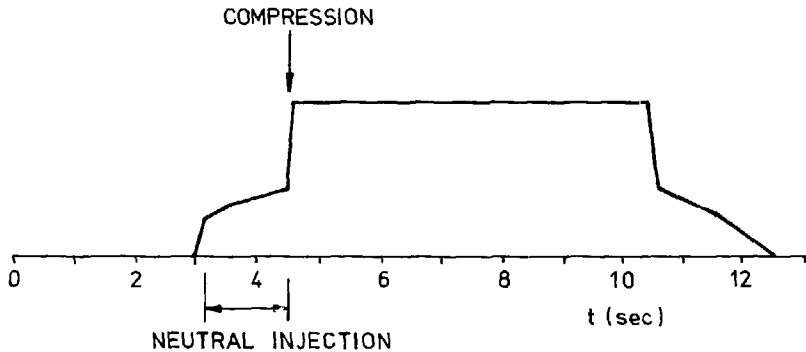

XBL 814-9243

Fig. 2.0.1-1 Time dependence of the current in the ZEPHYR vertical field coils

2. The time-dependent magnetic fields in the vacuum vessel would have a very large effect on the ion trajectories.
3. The analysis was so approximate that it would have to be backed up by modeling studies.

The trajectories of 160 keV D^+ ions at various times during the ZEPHYR operating cycle are shown in Figure 2.0.1.-2. Neutral injection begins at $t=0$ sec.

This study had the following impact on the beamline configuration:

1. It would not be feasible to dump the large power remaining in the ion beam in the portion of the vacuum vessel nearest the tokamak. The ion beam impact point depended too strongly on unpredictable time-dependent fields, and it did not appear feasible to provide adequate magnetic shielding for this large volume.
2. The choice was therefore made to use a reflection magnet to move the ion dump further from the tokamak and into a region of much weaker field (so that we could more nearly predict the point of impact of the ion beams) and to make it easier to provide magnetic shielding of that portion of beamline, should it be necessary.
3. It would be necessary to protect or remove cryopumps located in regions where stray ions produced by reionization of neutrals might strike.

The choice of a reflection magnet had the important and beneficial consequence that the ion dump could now be located external to the vacuum system. The water cooling lines are outside the vacuum envelope,

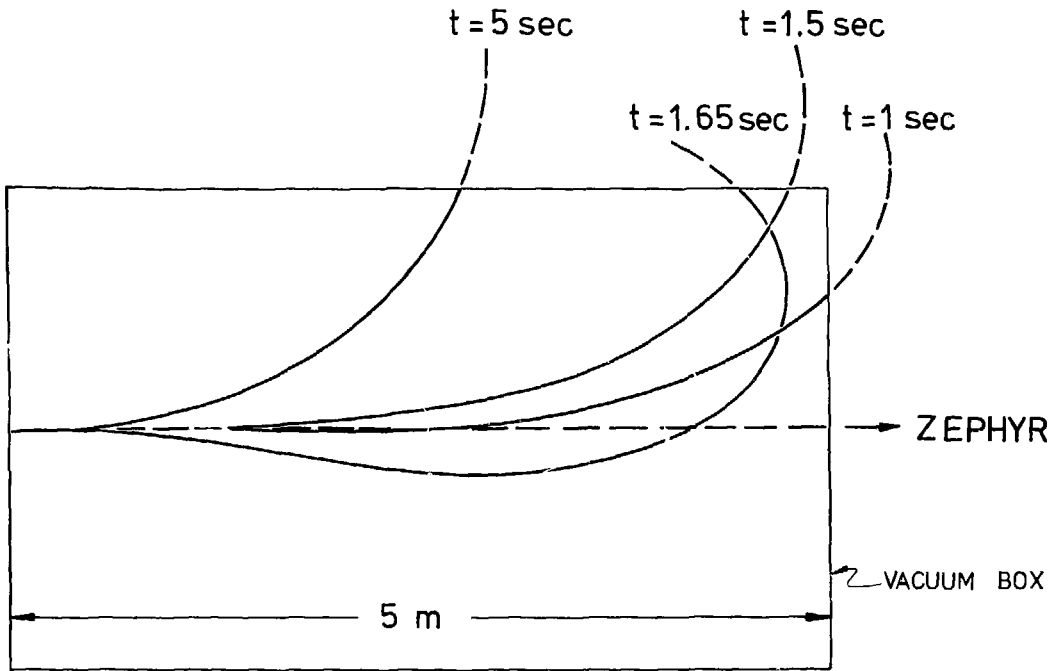

Fig. 2.0.1-2 160 keV D⁺ ion trajectories

XBL 814-9244

access for remote maintenance is much improved, and it is relatively easy to provide dynamic cooling, should that be necessary.

Another problem has to do with the perturbing effects of the beamlines on the tokamak magnetic fields. The design effort terminated before we were able to give serious consideration to this problem.

2.0.1.3. Remote Handling

The requirement that the system operate with tritium and the fact that the entire beamline would become radioactive due to neutron activation had a strong impact on beamline design philosophy. The beamlines would become contaminated with tritium from the tokamak. The tritium-handling safeguards at IPP are very strict, and would make it necessary to heat the internal surfaces of the vacuum vessel and all internal components to 150°C to remove tritium from the surfaces before large penetrations could be opened for removal or repair of components.

Neutron activation poses even more severe problems. Activation should be reduced as much as possible by proper choice of materials, such as the 5254 aluminum alloy selected for the vacuum vessel. Other beamline components, however, use large amounts of copper and iron, and would be so radioactive that they would have to be removed before "hands-on" work could be done on the vacuum vessel (if that in fact proved to be possible). Removal and replacement of major components would have to be done remotely, with overhead cranes and remote maintenance equipment (to be designed by IPP).

Because of the anticipated difficulties with remote handling problems, and to conform to ZEPHYR standards (see Appendix A), we laid down the following ground rules for our beamline design:

1. Electrical connectors and vacuum flanges (up to one meter diameter, designed by IPP) would be installed with suitable clearance for remote maintenance equipment.
2. Direct line-of-sight vertical access would be provided to all sensitive components (all cryopanels, ion and neutral dumps, and source modules).
3. Major critical components would be mounted separately, so that any one could be removed or replaced without disturbing others.
4. Vacuum penetrations and all connections to the external world would be minimized.

The major consequence of these decisions on the beamline configuration was that sources would have to be stacked side-by-side rather than vertically.

2.0.1.4 Source Layout

The most efficient source arrangement consistent with the ground rules given in the preceding sections, and with the source envelope dimensions given in the Working Specifications (Table 2.0.1-1) is one in which the sources are stacked horizontally, side-by-side, with the long axis of the 10 x 40 cm accelerator vertical.

Each source module consists of a source, the aiming mechanism, and the "core snubber" (a passive device to isolate the source electrically from the energy stored capacitively in the power supply and cables), and is an independent unit, complete with the required electrical and mechanical shielding. After we allow room to prevent electrical breakdown (in 1 atmosphere of SF₆) from the high voltage source to the

grounded case, and for magnetic shielding, we find that the minimum center-to-center spacing of the sources is 88 cm.

One remaining question to answer before we fix the beam layout is how many sources we can put side-by-side and still stay within the ZEPHYR angular acceptance criterion. This is mainly determined by the minimum distance between adjacent sources.

The angle of injection is defined to be the angle included between the beam centerline and the radius drawn from the center of the tokamak to the point at which the beam centerline intersects the plasma center. The range of angles acceptable for injection into ZEPHYR, together with the ranges required by three and by four side-by-side sources, is given in Table 2.0.1-2.

Table 2.0.1-2

Range of Injection Angles

Acceptable to ZEPHYR:	30° - 250°
Required by three sources:	8.6° - 24.6°
Required by four sources:	4.6° - 28.9°

As one can see in the table, three sources side-by-side produce beams that fit within the range of tolerable acceptance angles, but two of the beams from a four-source configuration fall somewhat outside that range. It is more cost-effective to use a configuration with four sources per beamline than one with only three. Had the project continued, IPP physicists would have extended their power deposition calculations to see if the range of injection angles we preferred

(corresponding to four sources per beamline) would have been acceptable to ZEPHYR. These calculations were not carried out, however, so for the conceptual design we show only a configuration with three sources per beamline.

2.0.2 Anticipated Performance

We calculated the anticipated performance of the ZEPHYR NBIS for both three and four sources per beamline. We chose unfocused sources; the power transmitted to the plasma target is reduced slightly compared to the value with the sources focused on the narrowest part of the duct, but the peak power density on the neutral dump (calorimeter) is reduced by almost a factor of four. Thus, we traded a slight decrease in power transmitted to the target for a modest simplification in source design and a great simplification in dump design; this trade-off permitted the use of simple and inexpensive thermal-inertia dumps, and avoided actively cooled dump designs.

The anticipated NBIS performance for both three and four sources per beamline is shown in Table 2.0.2-1. To meet the minimum injection requirements, five beamlines with three sources each are required, with no safety margin. To increase reliability, certainly six beamlines should be installed, the maximum number permitted. Five or six beamlines with four sources each would provide even larger safety margins. In subsequent sections, we consider only the configuration with three sources per beamline.

Table 2.0.2-1

ANTICIPATED PERFORMANCE

(UNFOCUSED SOURCES; 0.5° BY 0.8° BEAMS)

	<u>S O U R C E S P E R B E A M L I N E</u>		
	<u>THREE</u>	<u>COMMON</u>	<u>FOUR</u>
CURRENT PER SOURCE		50 A	
TARGET THICKNESS		$1.2 \times 10^{16} \text{ cm}^{-2}$	
BEAM LOSS DURING ACCELERATION		15%	
REIONIZATION LOSS		7%	
DUCT LOSS	1%		2.5%
GEOMETRIC TRANSMISSION TO PLASMA	81%		80%
NEUTRAL POWER TO PLASMA, PER SOURCE (160 keV/TOTAL)		1.04/1.68 MW	
NEUTRAL POWER TO PLASMA FROM 5 BEAMLINES	16/25 MW		21/34 MW
NEUTRAL POWER TO PLASMA FROM 6 BEAMLINES	19/30 MW		25/40 MW
NEUTRAL POWER TO PLASMA: DESIGN GOALS		15/25 MW	

2.1 Mechanical Configuration

2.1.1 Overall Beamline

The ZEPHYR Tokamak with six neutral beamlines, as installed in the Experimental Hall at IPP, is shown in Figure 2.1.1-1. Plan and elevation views of the individual beamlines are shown in Figs. 2.1.1-2 and 2.1.1-3 respectively.

Each beam line consists of three independently operated beam channels. The usual neutral beamline components - ion source, neutralizer, ion removal system, and neutral beam dump - are clearly seen in Fig. 2.1.1-3. The large structure directly below the source is a "core snubber" whose function is to protect the source in the event of sparkdown (see Sect. 3.5).

The overall beamline is 10.96 m from the exit grid to the center of the plasma; an additional 2.05 m is required for the SF₆ housing enclosing the source and core snubber. The angle between the centerlines of the channels is 5.2°. The estimated weight of the beamline (exclusive of its support carriage) is about 93 tonnes. The vacuum vessel containing the ion removal system and beam dumps is made trapezoidal in shape, in order to present a minimal front face at the tokamak. The beam centerlines are 3.5 m above the floor, the same elevation as the tokamak plasma centerline. Services, such as power, water, cryogen, etc., will be brought up from the basement through the 2m thick floor. The shielding enclosure has been extended to accommodate the 0.2 m travel necessary to roll the beamline away from the tokamak for servicing or removal. To facilitate access to the front-most components of the beamlines, such rolling can be done without

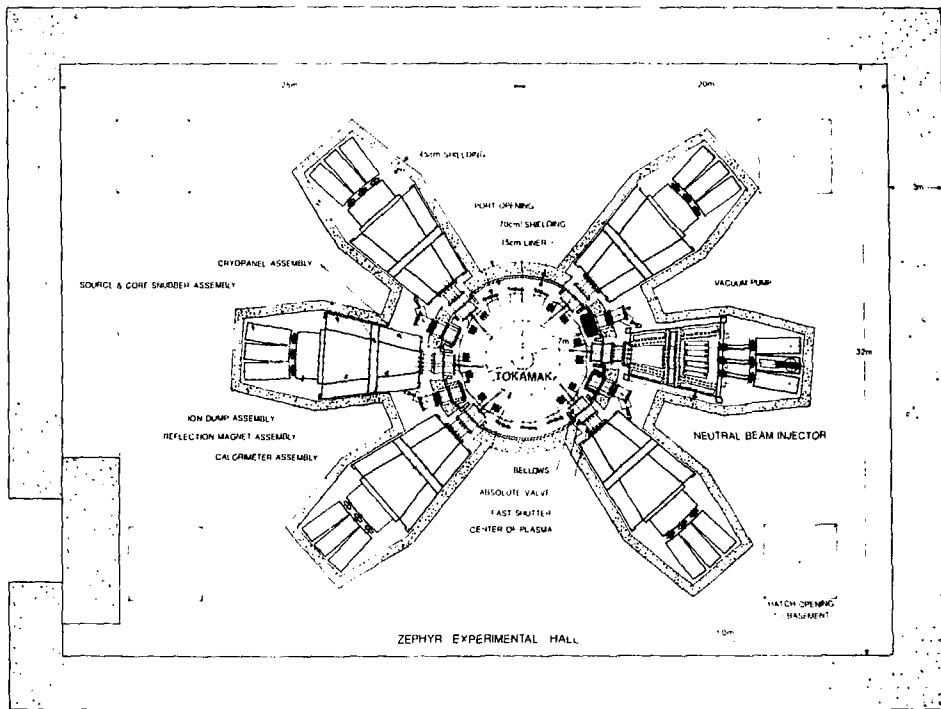

Fig. 2.1.1-1 Floor plan of ZEPHYR experimental hall showing tokamak and six neutral beamlines.

XBL 814-9235

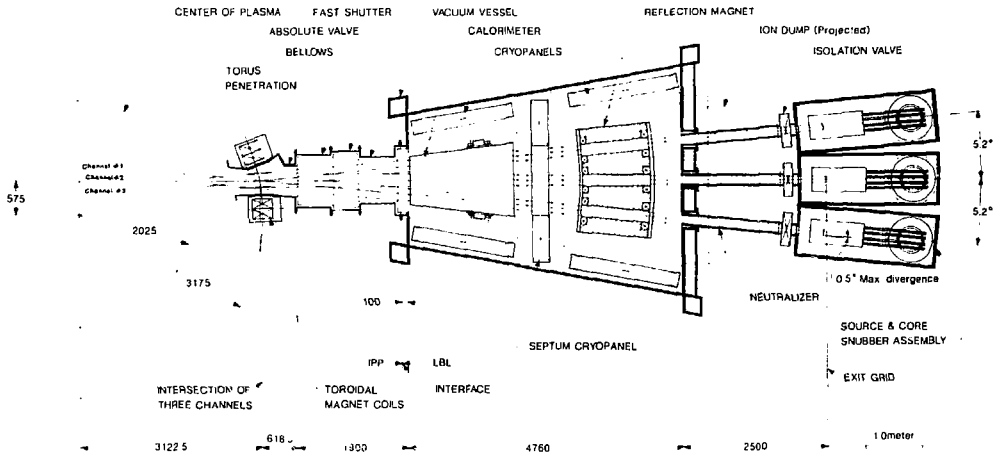

Fig. 2.1.1-2 Plan view of neutral beamline

XBL 814-9234

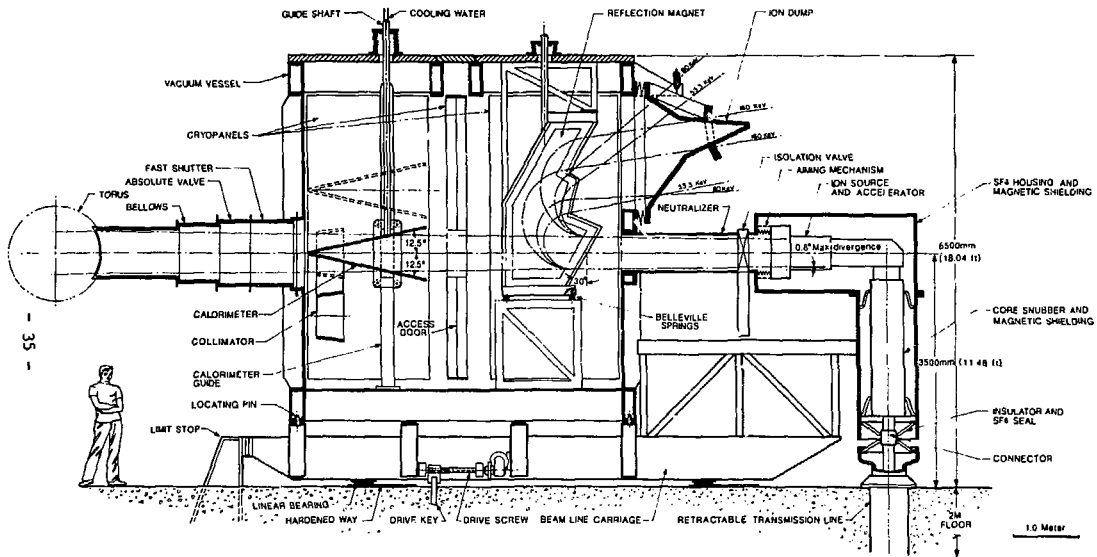

Fig. 2.1.1-3 Elevation view of neutral beamline

NBL 813-8482

disconnecting any services other than the transmission lines to the sources.

The beamlines must be accurately positioned relative to the tokamak, yet must be removable and/or interchangeable for servicing. Moreover, the beamline-tokamak interface must be able to accommodate expansion of the torus. The latter requirement dictates a flexible (i.e. non-locating) vacuum coupling. The former then dictates that the beamline support carriage serve to position the beamline to high accuracy; this implies not only an accurate means of locating the beamline on the carriage, but replacement of the railroad track support for the carriage specified in the ZEPHYR Interface Control Document (ICD) by a set of precision machined ways. Both these features are described in detail in Sect. 2.1.3.

Incorporation of the above features not only insures that the mechanical installation and removal of the beamlines can be done remotely, without the need for adjustment at final assembly, but also saves valuable operating time by permitting the various beamline elements to be pre-aligned in the hot cell, using a "dummy" carriage and duct, rather than at the torus itself.

As now conceived and shown in Figures 2.1.1-2,3 and in the exploded view given in Fig. 2.1.1-4, each beamline has all of its major critical components directly and independently accessible by overhead crane. The list of such components comprises the calorimeter, the magnet, the ion dump, each of the three source/snubber assemblies, and each of the five cryopanel; the neutralizer, at this stage, is assumed to be relatively trouble-free and not in need of replacement.

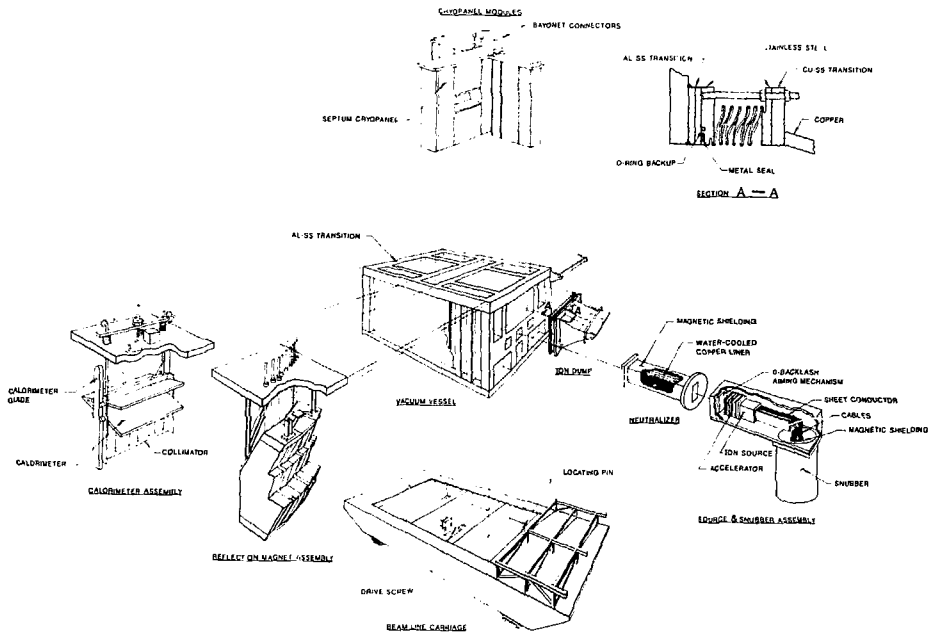

Fig. 2.1.1-4 Exploded view of neutral beamline showing principal components

XBL 814-9236

In an attempt to further facilitate servicing, as well as enhance reliability, we have taken the cooling water circuits for the ion dump and the neutralizer out of the vacuum envelope. (The magnet does not require any water cooling; see Sect. 2.2.4.2.) We thereby substantially reduce the chances of vacuum failure due to water leaks, or failure due to water freezing in the water passages inadvertently, and also cut down considerably the number of penetrations through the vacuum envelope. All vacuum joints employ metal seals backed by radiation-resistant elastomer seals. Quick-disconnect flanges of IPP design will be utilized wherever practical. The remaining flanges are to be designed so that fasteners are accessible to remote manipulators.

The major components are discussed in greater detail in the following sub-sections.

2.1.2 Torus Penetration And Duct

The torus penetration and duct assembly are to be furnished by IPP. The torus penetration terminates in a flange which is 1.8 m from the plasma. The duct assembly containing the bellows, fast shutter, and absolute valve, terminates in another 1.8 m in a second flange. This latter flange marks the interface of the tokamak with the beam line; systems on the tokamak side of the flange are the responsibility of IPP. As presently configured (see Figures 2.1.1-2,3), the torus penetration and duct assembly presents no clearance problem with the beams in either the vertical or horizontal plane.

2.1.3 Vacuum Vessel and Carriage

As described earlier, the beam line vessel is

trapezoidal in plan, with the front walls at 2.80 m overall width and the side walls canted at 10° . The front wall interior dimension is 2.25 m, the rear wall is 3.95 m, the axial length is 4.76 m, and the height is 4.95 m. The overall height from the top of the port covers to the bottom of the stiffeners is 5.50 m; to the floor, it is 6.50 m (when the beam line vessel is in position on its carriage). The beam centerline is 3.50 m above the floor. Vessel and lid weight is estimated to be 17.3 tonnes (38,000 lbs.).

The vessel itself is a weldment of 5254 aluminum alloy whose composition contains only 0.01% Mn, 0.15%- 0.35% Cr, 0.2% Zn, 0.05% Cu, and 0.45% Si and Fe (combined). Activation should therefore be at a minimum. The envelope itself is of 2.5 cm (1") thick material with Tee stiffeners 23 cm x 30 cm (9" x 12") spaced at 53.3 cm (21") (maximum center-to-center distance). To provide harder surfaces for the metal seals, the base Al flanges are faced with a composite transition material (metallurgically bonded) of aluminum and 300 series stainless steel. The transition material is to be a one piece picture frame for each opening and only the aluminum substrate is welded to the vessel weldment. This avoids corner welds of the transition and also avoids welding across the aluminum/stainless steel bond. At the top of the vessel, girders will frame seven openings for the calorimeter, the magnet, and the cryopanel, with the tops of the girders providing the base structures for the transition metal facings.

The bottom of the floor stiffeners will be finished to provide an exactly known distance to the centerline of the beam. At the bottom and along the axis of the center beam channel will be two bushed holes for engaging dowel pins on the carriage; the front hole nearest the tokamak

will be round while the rear one will be slotted. This arrangement will ensure accurate positioning and alignment of the beamline relative to the support carriage, while still allowing for axial movement due to thermal expansion. The weight of the vessel will rest on low friction bearing pads, such as sintered bronze matrix material impregnated with teflon.

The carriage will have its own low speed propulsion system with an electric motor driving a screw through a reductor and a slip-clutch. A precision (zero-backlash) slotted nut will engage a key set into the floor and the screw will then rotate to drive the carriage against a structural stop set into the floor. The stop will have been pre-adjusted to properly position the interfacing flanges which make up the vacuum seal, and the screw will act to hold the position.

Since the travel will be only 0.2 m, there is little justification for rails, called out in the ZEPHYR ICD (see Appendix A). Moreover, rails would not position the beamline with the required accuracy. We therefore propose instead that the carriage-positioning system be made like a large precision machine tool, i.e., hardened ways set into the floor, with matching heavy-duty recirculating linear bearings on the carriage. On one side, an inverted Vee way would mate with two sets of recirculating linear bearings to act as precision low-friction guides for the beamline. On the other side, a flat way would carry a single linear bearing without lateral restraints. The components for this system can be purchased as catalog items (e.g., Bendix Scully-Jones "Tychoway" bearings, which have a static capacity of 55,340 kg with matching ways, locking bars, etc.). Since the service is very intermittent and the speed very low, longevity should be no problem.

While the vessel itself rests on the carriage directly, the neutralizer, source isolation valve, source assembly housing, and core snubber housing will be supported by a space frame at the rear end of the carriage.

2.1.4 Source, Snubber, and Housing

The plasma source can only tolerate a stray magnetic field of about 0.5 Gauss, so magnetic shielding is required for the tokamak stray field of ~50 Gauss. Also, an enclosure is needed for the electronegative gas (SF_6) which will be at a pressure slightly greater than atmospheric. A rectangular housing of pure iron or SAE 1010 3 cm thick will be able to perform both functions. The bottom and front end plates will make a structural unit which will cantilever the source and accelerator assembly through a gimbal. The gimbal will allow for angular source aiming of $\pm 0.5^\circ$ in the vertical and horizontal planes through a zero-backlash mechanism. The mechanism is designed to minimize the probability that failure would allow the source and accelerator assembly to swing freely. For access, the top housing enclosure (shaped like an inverted open box) can be lifted off to completely expose the gimbal and drive, bellows, and source/accelerator assembly, as well as the source end of the power and signal conductors.

Because of the close proximity of source and snubber (to reduce capacitance on the source side of the snubber coupling), the snubber has its own magnetic shielding, designed to keep its axial field from penetrating the plasma source. This assembly is in its own SF_6 enclosure mounted underneath the source housing.

The entire L-shaped assembly is designed to be installed and removed as a unit. In the operating location, the weight is carried by the space frame at the end of the carriage. A connector at the bottom also forms the gas seal for the SF₆. A poppet valve opened by a mating connector will allow water to flow into a drain in case of a cooling circuit rupture. Connection and disconnection of the transmission line is made by the lower line being jacked up, or retracted from the basement.

2.2 Subsystem Performance Characteristics and Details

The following sections describe the characteristics and design details, as far as they have been determined, of the various subsystems of the ZEPHYR Neutral Beam Injection System (NBIS).

2.2.1 Ion Source

The ion source must provide a uniform current density of ions over the 10x40 cm accelerator array, for pulse lengths of 1.5 sec; to meet ZEPHYR power injection requirements (Table 1.1.1-1), it must put out at least 80% D⁺ ions (the rest being D₂⁺ and D₃⁺). The design goal for the lifetime of all components except the ion source filaments was specified in the ICD to be 2x10⁵ shots (see Appendix A). To attain this goal for the filaments as well, an improved cathode would need to be developed; failing that, a means would need to be devised for easy cathode replacement by remote-maintenance equipment. Both these approaches would be pursued during the course of the project.

For design purposes, we selected a source of the "bucket" type; the source power requirements listed in Table 2.0.1-1 reflect this choice, and are appropriate for this type of source. Extensive prototype testing and development would be required in this area. A typical source of this type is shown in Fig. 2.2.1-1, which shows a TFTR accelerator and a "bucket" plasma source.

2.2.2 Accelerator System

2.2.2.1 Insulator structure

The requirement that sources be stacked as close to one another as possible dictates that the insulator must be rectangular, rather than round. Because of uncertainties in producing and brazing insulators larger than the current sizes being used for TFTR and Doublet III sources, we chose to maintain that size also for ZEPHYR sources. Technology for fabricating these insulator structures is proven; the technique involves brazing the Al_2O_3 insulator sections to thin titanium sections, then welding the brazed assemblies together to form the complete high voltage insulator module.

2.2.2.2 Stored Energy

Repeated experiments at LBL have shown that when sparking occurs under conditions in which

- 1) the stored energy exceeds about 5 Joules, and

- 2) the current in the spark exceeds a few hundred amperes,

some sparks seriously degrade the voltage-holding ability of the accelerator structure, and require reduction of the beam voltage and "re-conditioning" back to full operating voltage. This situation should be avoided to maximize source availability.

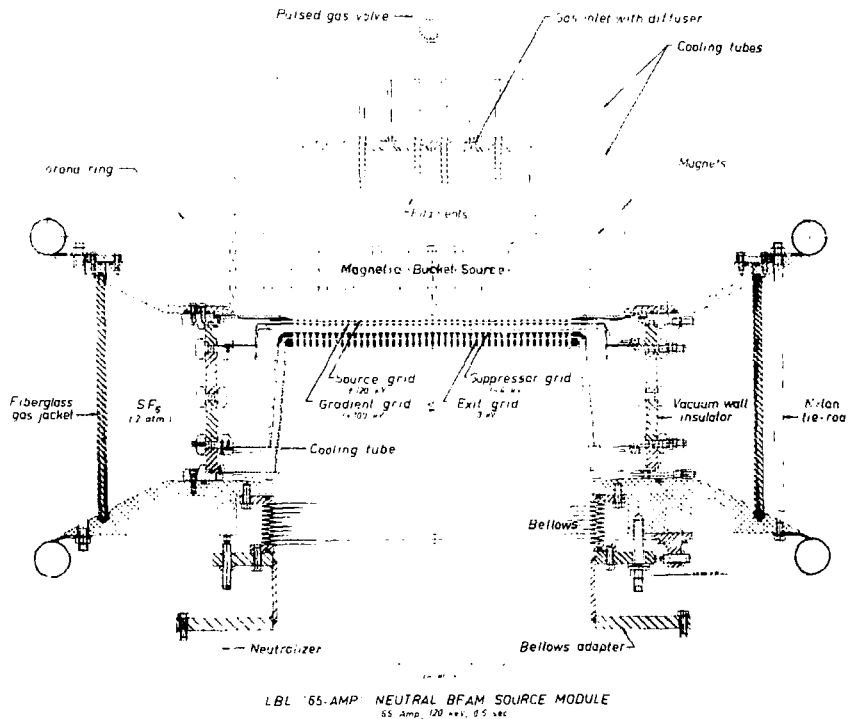

Fig. 2.2.1-1 Bucket source and accelerator for TFTR

XBB 787-8075

We measured the capacitances in the TFTR accelerator structure, which is very similar to the one we propose for ZEPHYR. The TFTR design operates at 90 kV/cm in the second (high-voltage) gap of the accelerator, and stores about 0.9 J in the accelerator alone (more energy is stored in the stray capacitance of the source, cables, etc). The design chosen for ZEPHYR should increase the energy stored in the source to only about 1.3 J, and so probably would not exhibit these "degrading" sparks. Testing would be required to verify this.

2.2.2.3 Electrode Design

The basic electrode configuration, which we have used successfully at 80 and 120 keV, uses four electrodes. The first, in contact with the plasma in the plasma source, serves as a "beam-forming" electrode. Its principal purpose is to give the ion beam an initial convergence, in order to compensate for the diverging effects of the beam space-charge and for the diverging lens action of the hole in the electrodes near ground, and also to control aberrations at the edge of the beam. The second electrode, the "gradient grid," aids in forming the desired potential distribution along the beam as it is accelerated. The third electrode, the "suppressor," is biased negatively with respect to ground, and prevents electrons from the plasma in the neutralizer from being accelerated back through the accelerator structure into the plasma source. The fourth electrode, the "ground" electrode, forms a final ground plane and reduces (because of its geometric transparency) the magnitude of the ion current accelerated from the downstream plasma into the suppressor electrode.

Ion trajectory calculations made using the WOLF code (Fig. 2.2.2-1) indicated that an electrode configuration similar to that used for TFTR

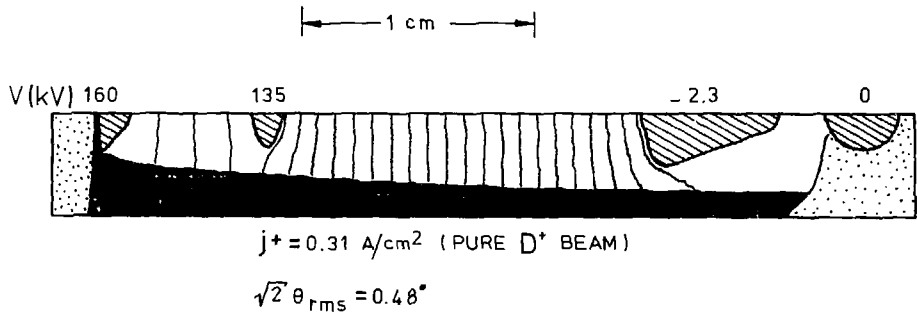

XBL 814-9169

Fig. 2.2.2-1 Ion trajectories through a ZEPHYR accelerator structure calculated using the code "WOLF"

and (uncooled) Doublet-III sources would be suitable, except that the inter-electrode gaps must be lengthened to maintain the maximum electric field at 90 kV/cm, the design value for the TFTR and Doublet-III grids. This electrode configuration would operate at 160 kV at a D^+ ion current density of about 0.3 A/cm^2 , the same as TFTR. To enhance reliability of operation, we would lengthen the inter-electrode gaps even more, and reduce the net output per source module to 50 A (a source with the electrode configuration shown in Fig. 2.2.2-1 would put out about 65 A).

The decision whether or not to water-cool the electrodes must await further experimental tests. There is a good chance that the electrodes would not need to be actively cooled for 1.5 sec pulse length, which would simplify the design and reduce construction costs for the source.

2.2.3 Neutralizer

The neutralizer has been designed to achieve a neutralization efficiency of 95% of that obtainable with a neutralizer of infinite thickness (∞). For 160 keV deuterons, this gives a thickness of $\lambda = 1.6 \times 10^{16} \text{ D}_2 \text{ molecules/cm}^2$. Our computations were made assuming a neutralizer gas temperature of 500 K. If the gas temperature is reduced, the resulting decrease in neutralizer conductance causes an increase in gas density and hence in neutralization efficiency; thus the design is conservative for a water-cooled neutralizer.

To calculate the neutralizer gas density we first calculated the conductance of the source-grid-neutralizer assembly under the assumption

of molecular flow (corrections for transition flow are minimal). From this, we computed the pressure distribution for this structure with a normalized 1 Torr-liter/sec gas load at the source. It was determined that the required neutralization efficiency could be achieved with a 2.5 meter long neutralizer with a gas load of 20 Torr-liter/sec introduced at the source.

The neutralizer structure is made from copper with external water cooling. Provisions are made for additional gas injection at selected points along its length. An iron magnetic shield surrounds the copper neutralizer tube. Since the neutralizer is external to the NBIS vacuum vessel, it is readily convertible to a cold (LN₂-cooled) design. Should further analysis indicate that this feature would be advantageous, local differential pumping to provide steeper pressure gradients in the neutralizer will also be considered for the final design. Using a cold neutralizer and/or providing differential pumping could provide the required target thickness while significantly lowering the gas flow out of neutralizer and reducing the heat load on the source grids.

2.2.4 Ion Removal System

The charged particles are removed from the beam by a magnet which reflects them in the vertical plane back to an inertial beam dump whose entrance is at the plane of the neutralizer exit (see Fig. 2.1.1-3). The reflection magnet option was selected to limit the charged particle beam orbits to the weaker regions of the tokamak's fringe field. A transmission magnet would have placed the beam dump in a location where the fringe fields would have posed severe problems of magnetic shielding (see earlier discussion in Sect. 2.0.1.2).

A major consideration in designing the beam dump system was that the components be consistent with existing or well known technologies. Thus, the design constraints were chosen to limit power densities at the beam dump to less than 1.7 kW/cm^2 . This is near the upper limit of power density with a 1.5 sec pulse length for acceptable temperature excursions in a copper inertial beam dump.

In order to achieve this goal, the magnet geometry was selected to defocus the beam significantly at the beam dump location. This task was made more difficult since the drift length to the dump was limited by the constraint of beamline size and by the requirement for vertical access to the source module, which is located below the beam dump. Also, increasing the beam size in the horizontal direction as it passed through the magnet was not allowed; collisions with the magnet pole pieces would generate gas and, because the magnet gap is poorly pumped, a gas source in that region would significantly increase beam loss due to reionization of the neutral beam.

Calculations using the parameters for the selected magnet geometry and beam orbits (see Fig. 2.2.4-1 and sections 2.2.4.1-3) indicate that the maximum power density at the beam dump is less than 1 kW/cm^2 , providing a generous safety margin for operation of the inertial beam dump. The calculations assume 33% neutralizing efficiency for the full-energy component, and $1/e$ divergences of $.8^\circ$ and $.5^\circ$ in the directions perpendicular and parallel to the source grids, respectively.

2.2.4.1 Beam Optics

The restriction on the horizontal beam size was achieved by having the entrance beam make an angle of 30° with the normal to the magnet face. This focusses the beam in the direction

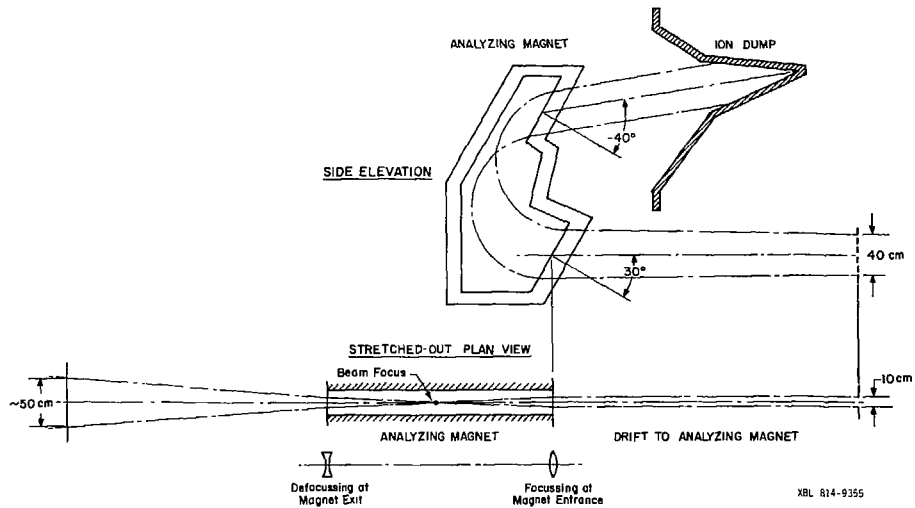

Fig. 2.2.4-1 Beam optics for ion-removal system

perpendicular to the bend plane at a point roughly two-thirds of the way through the 170° reflection magnet. The diverging beam leaves the magnet at an angle of -40° relative to the normal to the magnet face. This further defocusses the beam and spreads it as it drifts to the dump, creating a significant enlargement of the beam size perpendicular to the bend plane.

A rather generous 75 cm bend radius was chosen for the D^+ species to prevent the third-energy beam from being reflected back into the neutralizer. The rather complicated shape for the exit face of the magnet was chosen so that the lower energy beams would also find their way to the beam dump. It may be possible to simplify the shape by further design effort. In any event, a rigorous modeling program will be necessary due to uncertainty about the magnetic field at the interior corners; testing would include wire orbit measurements of the model magnet. Increasing the 75 cm bend radius results in increasing the focal length of the magnet and reduction of the defocussing effect at the dump. Thus, the minimum bend radius was selected.

2.2.4.2 Analyzing Magnet

The magnet design has three 20 cm gaps oriented vertically, one for each beam channel, in a single yoke structure. The magnets are excited to approximately 0.1 Tesla, with individual coil circuits for each beam channel.

Since the yokes for adjacent beam channels are common, and since the magnet leg segments also share flux for the various beam channels, the magnetic reluctances for the separate beam magnet circuits are coupled. Also, the fringe fields from the tokamak are large and they, too, couple

into the analyzing magnet circuit. To compensate for these coupling effects, instrumentation to measure the field in each gap is needed for adjustment of the individual power supplies.

The coil cross-section is made large to permit a low current density in the coil. This, plus the facts that the magnet can be pulsed and the duty factor is low, permits the use of solid conductor coils. The coils (and leads) can then be air cooled by enclosing them in a vacuum-tight aluminum jacket which penetrates the magnet port cover. Elimination of the water cooling not only simplifies the coil design but also removes the possible hazard of water freezing in the magnet coils and water feed lines. This hazard exists for water-cooled designs due to the presence of nearby cryopumps.

The magnet is massive, and its support system is designed to suspend the magnet and its services from an independent mounting plate. The entire structure must be designed for balance so that installation and removal can be accomplished with the mounting plate horizontal (as it must be to make the vacuum seal to the tank) when suspended from a crane. In its operating position, the magnet is keyed into a support structure which will provide lateral restraint. Moreover, some of the weight load will be removed from the mounting plate by the use of spring washers on the support stand (see Fig. 2.2.1-3).

2.2.4.3 Beam Dump

The ion beam dump is a "Vee" structure, as shown in Fig. 2.1.1-3. The dump is mounted in a strong-back structure which will both limit its thermal deflection and also provide a means of supporting it from the brackets on the vessel. The dump itself is made

from copper and is water-cooled. The water channels are made by milling grooves into the back side of the copper plates, and welding on cover plates to enclose them.

The Vee is oriented such that the intersection of the two plates lies in the horizontal plane, perpendicular to the long axis of the rectangular ion source. Thus, the beam "footprint" on the dump is amplified in the "short" direction by the optical properties of the magnet, and in the "long" direction by the inclination of the copper plate with the beam axis. There are two main advantages to this geometry:

1. A single mechanical structure serves as a beam dump for all three sources.
2. Ion beam steering errors due to tokamak fringe field effects on the ions are not critical.

A possible disadvantage is that although the maximum calculated power density for the simpler geometry is modest, the relatively narrow beam image in the "short" direction may present some thermal stress/fatigue problems due to the large power density gradient. This will create a temperature gradient in the direction along the plate faces whose resultant stresses must be carefully analyzed before the simple single "Vee" structure is adopted. The analysis will consider fatigue and crack growth as well as evaluation of stress magnitudes and distribution.

In the event the thermal stresses prove unacceptable, we have worked out an alternate design in which the dump consists of three Vees

oriented with their intersections parallel to the long beam axis. (The power density gradient is much larger in the "short" source direction than in the "long", and the inclined face of the beam dump serves to reduce the effective gradient in only one of these directions; in the present configuration, it serves to reduce the smaller gradient.)

The reflection magnet option allows mounting the beam dump at the back of the vacuum vessel. The copper structure is thermally and mechanically isolated from the flange which mounts the dump to the vacuum tank by a large rectangular bellows, which is welded to the dump through a copper-to-stainless-steel transition material. The strongback support relieves the bellows, as well as the adjusting screws, of the weight load of dump. The water circuits are all in air, and thus require no complicated and costly water feedthroughs into the vacuum space. The hazards associated with water spillage into the tank are also reduced thereby. Access for removal or maintenance is also enhanced by this external mounting.

Instrumentation for calorimetric measurements of the charged beam are attached to the air side of the beam dump. The maintenance and serviceability advantages for instrumentation mounted in this manner are self-evident.

2.2.5 Calorimeter

The calorimeter is a 25° Vee-shaped structure made from two copper plates whose intersection line lies in the horizontal plane, perpendicular to the long ion source axis. All three beams use the same 25° Vee. The separations between the beam imprints for the

anticipated beam divergences are adequate and no significant overlap is anticipated. The copper plates are thick (~5cm) and employ the same type of water-cooling channels as used for the ion beam dump (see Sect. 2.2.4.3). The thermal time constants for heat diffusion in the transverse direction for this geometry are long compared to the 1.5 sec beam pulse length. Thus, temperature sensors mounted to the backs of these plates will give accurate power density profiles.

To maximize the reliability of the water system, we have eliminated all flexible hoses, since these tend to fail under pulsed duty, and also eliminated all movable water-system joints inside the vacuum system. The latter objective is achieved by bringing the calorimeter cooling water in and out through the same tubes which are used to position the calorimeter vertically. The vertical motion can be accommodated in the external water circuit through the use of rotating joints (similar to those used as seals on pump shafts), thereby permitting the use of rigid water lines throughout.

The water circuits are designed for a minimum number of parallel circuits so that blocked lines can be easily detected from external flow/pressure drop measurements. The lines will be sized so that all lines can be blown down and emptied of water when the system is not in operation. This will protect the circuits from freezing due to radiant heat transfer to the LN_2 cryopanel shield.

The calculated maximum beam power density on the calorimeter is 1.1 kW/cm², which is below the upper limit for an inertial power-absorbing structure. However, the power density gradient for this inclination of calorimeter is severe, and as in the case of the ion dump, further calculations of the thermal stresses with consideration of fatigue

performance and crack growth rate must be performed. If it appears that the design is marginal for thermal stresses, a design with the throat of the calorimeter rotated 90° about the beam axis will be adopted. This design will require three Vees (a more costly design) and will make the mechanical positioning tolerances of these heavy devices more critical. For either the one- or three-vee design, guides and supports internal to the vessel will be used to provide lateral restraint to relieve any bending moment on the feed-through bearings which permit the calorimeter to move vertically.

2.2.6 Vacuum and Cryogenic Systems

The "baseline" NBIS design includes 50 m^2 of cryopanel area. This is the upper limit of cryopanel surface area which can be easily placed in the vacuum enclosure.

It is instructive to examine the origins of the increased cryopumping requirements of ZEPHYR as compared with the TFTR NBIS (30 m^2) and the Doublet-III NBIS (15 m^2). The TFTR source operates at 120 keV. The neutralizing efficiency at this voltage is higher than at the 160 keV level specified for ZEPHYR. Thus, the ZEPHYR neutralizer gas load and ion dump gas loads are significantly greater than those anticipated for TFTR. The Doublet-III NBIS includes two 80 keV hydrogen sources, as compared with three 160 keV deuterium sources required for ZEPHYR. The neutralizing characteristics are equivalent; however the specific pumping speed per unit area for hydrogen is 40% greater than for deuterium.

It may be possible to further reduce the total area of the cryopanel by up to 20% through careful optimization of the location of the

cryopanel modules and positioning of the various beamline components to maximize the conductances to the cryopanel from the various gas sources, as well as through reduction of the total gas load as a result of further development of the neutralizer structure. However, to be conservative, 50 m^2 is used as a working figure for estimating the cryogenic distribution and supply requirements.

2.2.6.1 Cryopumping Performance

Five cryopanel modules pump the 71

Torr-liters/sec total deuterium gas load predicted for the NBIS. The calculated pressure distribution ranges from 1.2×10^{-4} Torr at the neutralizer exit to 2×10^{-6} Torr in the torus duct area (see Fig. 2.2.6-1). The calculated pressure line integral from the entrance of the analyzing magnet to the duct is approximately 1.2×10^{-4} Torr-m (see Fig. 2.2.6-2), which translates to a predicted reionization loss of approximately 5.5% of the full-energy neutrals. (The region between the neutralizer exit and analyzing magnet entrance is treated as an extension of the neutralizer.) The calculated reionization loss from the magnet exit through the torus duct system is approximately 1.5%. (The TFTR and Doublet NBIS predicted losses are comparable.)

Measurements of the NBSTF cryopanel performance will be used to refine cryogenic load estimates. Cooldown and regeneration of the ZEPHYR cryopanel should be accomplished at least as quickly as for the NBSTF cryopanel, because of the lower thermal inertia of the proposed design and relative insensitivity to temperature changes (see Sec. 2.2.6.3).

Operation of the neutralizer at 77 K is being seriously considered (see Sec. 2.2.3). At this temperature the gas load can be reduced by a

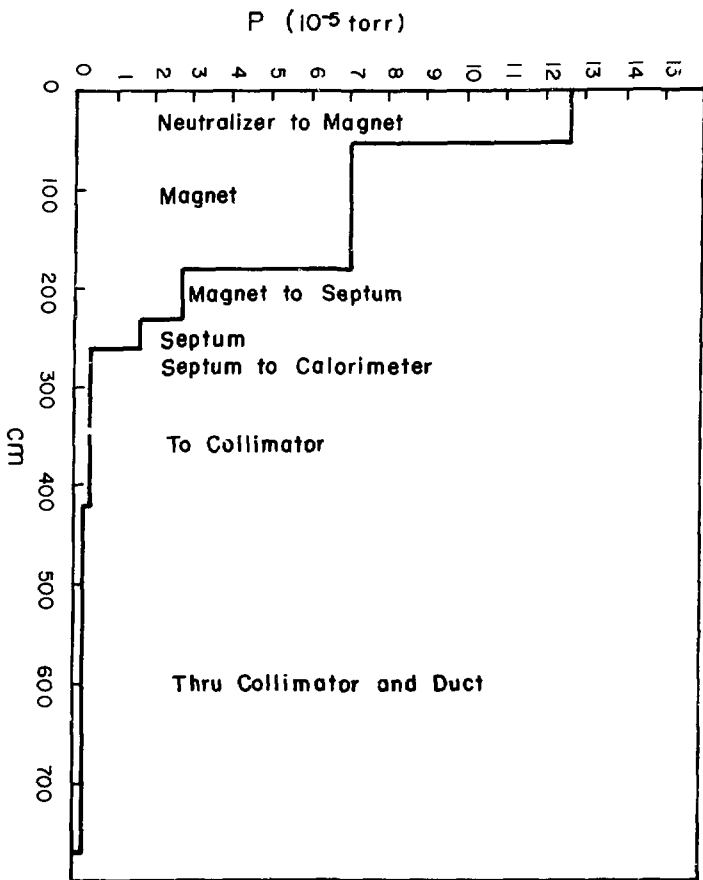

Fig. 2.2.6-1 Pressure distribution along beamline

XBL 814-9249

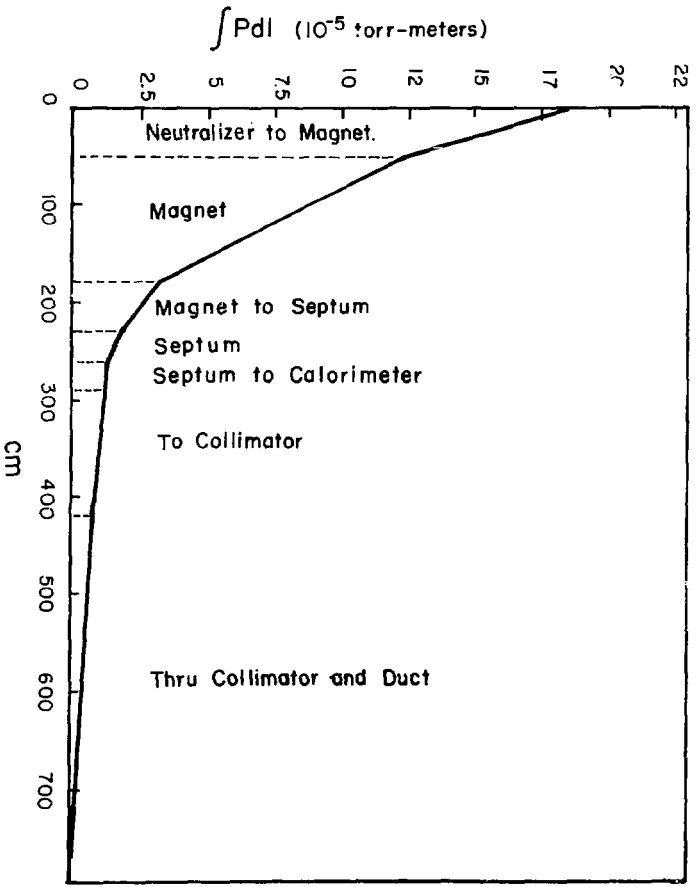

Fig. 2.2.6-2 Pressure Line-Integral calculated from duct entrance

XBL 814-9245

factor of two without affecting the neutralizer performance, and would permit a significant reduction in cryopanel area.

Anticipated cryogen consumptions, based on preliminary NBSTF results, are given in Table 2.2.6-1. As additional data become available from NBSTF on cryopump performance and system behavior (re-ionization loss, etc.), we will modify the ZEPHYR NBIS conceptual design as necessary.

Table 2.2.6-1

Estimated Cryogen Consumption (Per Beamline)

Liquid Helium	100 liters/hour*
Liquid Nitrogen	260 liters/hour*

*Recent measurements at NBSTF indicate that the actual load may be only 35-50% of this value.

2.2.6.2. Cryopanel Configuration

Two cryopanel modules are mounted in the neutralizer-magnet region. This is the region of highest pressure and hence the pumping performance here affects the pressure throughout the remainder of the system. Although we have maximized the possible cryopanel surface area in this region, the effectiveness of these panels is limited by conductances from the beam region.

A septum cryopanel separates the neutralizer-magnet region volume from the calorimeter region. This cryopanel pumps on both sides, and contains an opening for beam passage. The cold area of this module can possibly be reduced or armored if necessary, with minor effects on the reionization losses.

Two of the modules of the cryopump in the calorimeter volume may be reduced or eliminated altogether, increasing beam losses only slightly. These modules are desirable to reduce gas flux from or to the tokamak. The calorimeter region is also pumped by one side of the septum cryopanel.

The vacuum system performance calculations indicate that up to 1.5% of the neutral beam may be lost due to reionization beyond the analyzing magnet. Although some magnetic shielding is provided by the eddy currents in the aluminum vacuum tank, enough of the tokamak fringe field penetrates the beam volume so that reionized neutrals may collide with the cryopanel. Large sections of the calorimeter cryopanel may need to be either shielded or eliminated. Further study needs to be performed on the specific requirements for protection or removal of sections of the cryopump modules.

2.2.6.3 Cryopanel Construction

The cryopanel modules are LN_2 cooled chevrons shielding the LHe cooled panel (see Fig. 2.2.6-3,4). The cryogenic distribution circuits are tubular, with plates brazed to the tubular structure to extend the helium-cooled areas for larger cryopumping area. This type of structure is insensitive to large temperature gradients, so that thermal stresses are not a factor in rapid cooldown and warmup cycles. The mechanical flexibility of the tubular circuitry allows one to avoid the use of bellows, whose pressure capabilities frequently constitute a design limit for the cold circuits. Bellows are designed into the air/vacuum interfaces for mechanical flexibility in assembling the structure, thereby permitting relatively relaxed mechanical tolerances (see Fig. 2.2.6-5).

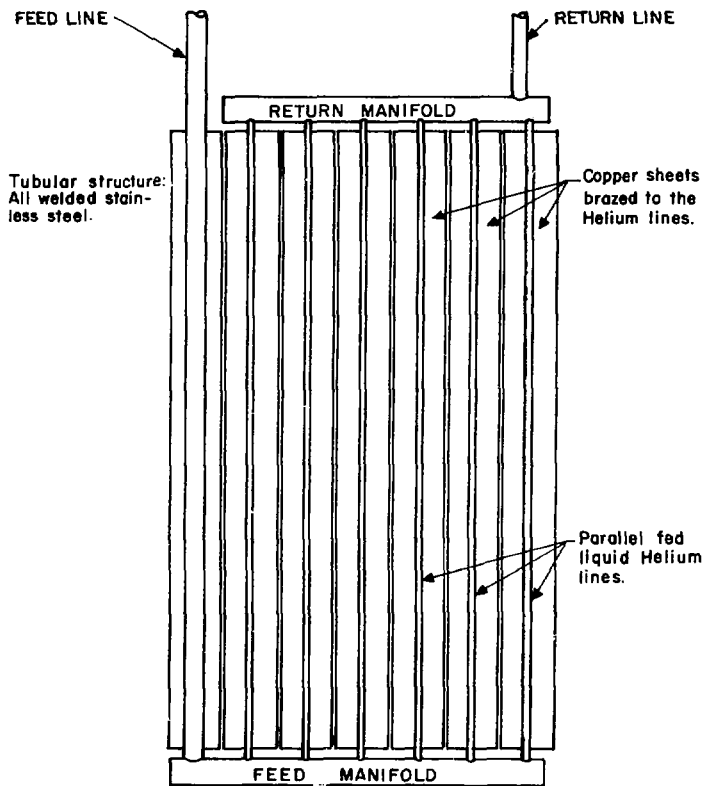
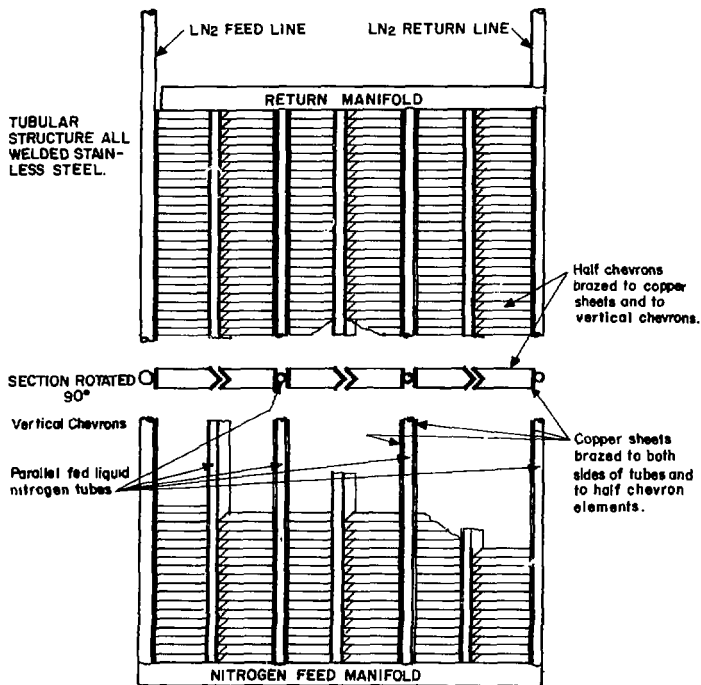

Fig. 2.2.6-3 4.2 K helium-cooled cryopanel surface

XBL 814-9246



XBL 814-9247

Fig. 2.2.6-4 77 K liquid-nitrogen-cooled chevron shields

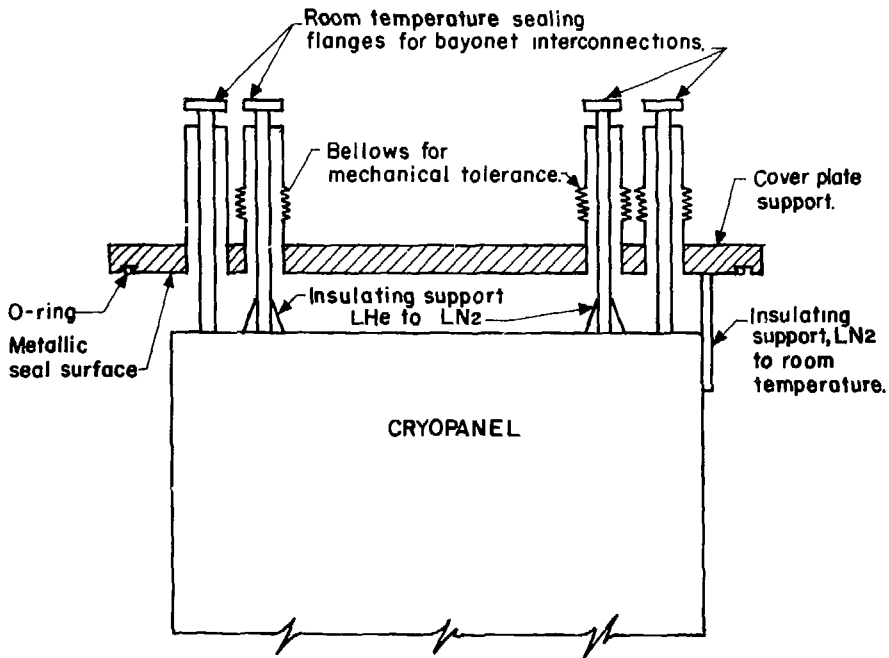

Fig. 2.2.6-5 Cryopanel support system

XBL 814-9248

Four of the five cryopanel s are of identical design; the fifth will be designed to pump on both sides. Each cryopanel is mounted on its own support plate for independent mounting or removal. Cryogenic circuit connections are external to the vacuum tank and use bayonet type connectors.

2.2.6.4 Cryogenic Circuitry

The six NBIS must be fed with LN₂ and LHe. The topology of the system makes individual parallel feed to all the units impractical, because of the excessive transfer line lengths required and the valves needed for flow control and isolation. It is proposed that the cryogenic feed be divided between two circuits, each feeding three NBIS from the central liquid helium refrigerator and LN₂ supply dewar, as shown in Fig. 2.2.6-6. The three NBIS are fed in series, with the boil-off gas being collected in return manifolds. Because of the series-feed arrangement, the flow through an individual NBIS may be up to three times greater than needed for its load. However, the pressure drop is proportional to m^2/d^5 , where m is the mass flow rate and d is the tube diameter; thus, increasing the flow cross-section diameters by 60% will more than compensate for the increased pressure drop due to trebling the mass flow rate. For similar reasons, the individual cryopanel s on each beam line will also be fed in series. Valving will make possible the bypassing of individual beam lines and/or cryopanel s.

2.2.7 Miscellaneous Auxiliary Systems

2.2.7.1 Water

Water requirements for the power supplies,

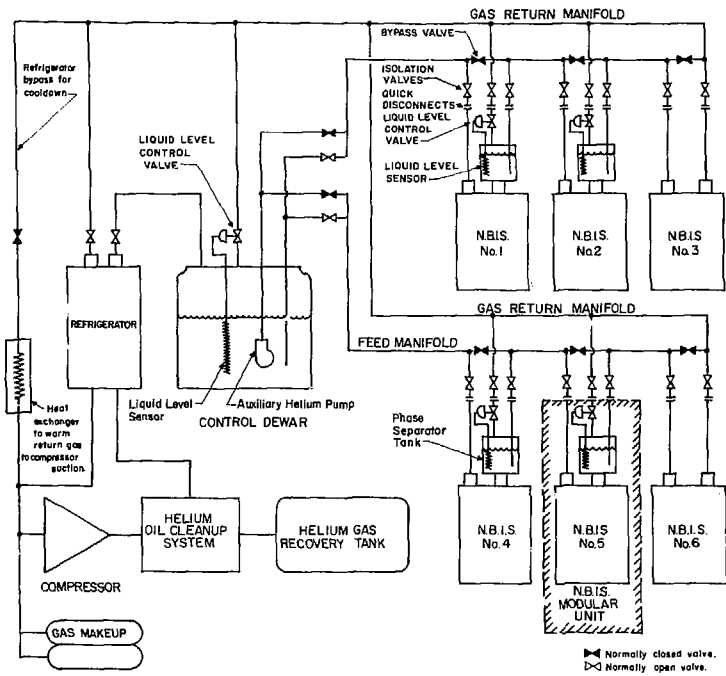

Fig. 2.2.6-6 Liquid helium distribution system

XBL 814-9354

calorimeters, beam dumps, and neutralizers have not yet been determined. Water cooling of the source grid is being considered. All water systems will include valving for isolation, orifices for flow monitoring, and thermocouples for temperature sensing. Interlocks controlling primary power systems using the signals from both flow and temperature sensors will be fed into the system interlock chain.

2.2.7.2 Rough Vacuum

Trapped roughing pumps will bring the pressure in the NBIS tanks down to the level where the turbomolecular pumps can be started. The turbo pumps are sized to bring the pressure in the NBIS tank to the low 10^{-5} Torr range, sufficiently low so that the cryopumps can be safely turned on.

2.2.7.3 Pump and Purge

A rough pumping system and a helium gas source will be required to pump and purge the cryopumps and the various distribution circuits, helium refrigerator and dewar.

2.2.7.4 Liquid Helium Refrigerator

The cryopumping system load for five or six NBIS is approximately 700 to 800 watts at 4.2 K. A central storage dewar and a helium circulation pump (for operation during refrigerator shutdown) will be required.

2.2.7.5 Liquid Nitrogen System

Up to 1000 liters/hour of liqu'd nitrogen will be required for six NBIS. This can be supplied from a large storage dewar. A collection manifold should be installed for the boiloff gases which may present a suffocation problem if allowed to collect in low areas as the basement power supply areas.

3. POWER SUPPLIES

3.0 Introduction

3.0.1 Design Philosophy

Throughout the study and the development of the power supply (PS) configurations for the ZEPHYR Neutral Beam Injection System (NBIS), we have set as our goals high reliability, short construction schedules, and low cost. To achieve these goals we have tried as much as possible to adhere to the following three guidelines:

1. employ proven techniques;
2. avoid complex approaches;
3. choose equipment which is either commercially available or readily fabricated by private industry.

The proposed arrangement for the accelerating (accel) PS arrangement, for example, is an outgrowth of this philosophy and will be seen to be far less complex than other similar supplies under construction or in operation. All major components of the supplies we propose (which are almost invariably made-to-order-as-per-specification items) are well within existing industrial fabrication capability.

One of the guidelines for the ZEPHYR NBIS sub-system has been that it should be delivered to the IPP site as a turn-key system. For this reason, among others, the earliest possible construction and testing (into a NB source load) of a prototype power system or the first production system would be highly desirable. This should be done sufficiently in advance of the completion of following systems to permit the incorporation of any necessary changes in them.

3.0.2 LBL Experience

For approximately 10 years, LBL has pursued a program of NB source development which has recently culminated in the designs chosen for the LLNL 2XIIB, TMX, and MFTF mirror experiments, the PPPL TFTR machine, and the General Atomic Doublet-III experiment.

Innovative power system development has necessarily paralleled the NB source program since in a number of instances, the program's special requirements could not be met by the currently existing technology (e.g., in the area of high-power radar modulators).

Over the years, whenever possible, we have chosen solid-state designs for such functions as accel PS switching and arc PS modulation because of our belief, vindicated by subsequent performance, in the potential reliability attainable with this approach. We have gained an appreciation for the necessity of understanding the cause of virtually every possible voltage and current transient under all normal and abnormal operating conditions. This understanding has enabled us in every case to control or eliminate the adverse effects of such transients. It has also been applied in our techniques for grounding and appropriately laying out and shielding signal and control leads. This has resulted in operating environments which are remarkably electrically noise-free, even in the presence of nearby multi-megawatt NB source sparking.

Table 3.0.2-1 lists some notable milestones in the NB power system development program. The next-to-last listing refers to the present upgrading of our largest facility (NBSTF), which had been constructed for 120 kV, 80 A, 1.5 sec, 1% duty testing of TFTR sources. The 30 sec, 170 kV accel PS (for NBETF) will employ solid-state ac primary

Table 3.0.2-1

LBL NB POWER SYSTEM MILESTONES

June 1972	20 kV, 10 A, 0.01 sec, 7 x 7 cm Source
September 1973	First Test of 20 kV, 70 A Accel, 7 x 35 cm Source
October 1973	19.5 kV, 70 A, 0.01 sec Without "Arc Notch"
February 1974	20 kV, 80 A, 0.01 sec With "Arc Notch"
August 1975	40 kV, 70 A, 0.01 sec, 7 x 35 cm Source
March 1976	Start Construction of 120 kV, 20 A, 0.5 sec PS
March 1977	First Beam at 120 kV, 20 A, 0.5 sec, 10 x 10 cm Source
July 1977	TS IIIB Arc and Fil. Tests, 10 x 40 cm Source (TFTR)
July 1977	Start Construction of NBSTF (TFTR) System
August 1977	Began Test of TS IIIB 120 kV, 75 A, 0.030 sec Accel PS
September 1977	35 kV on 10 x 40 cm TFTR Source, TS IIIB
January 1978	68 kV on 10 x 40 cm TFTR Source, TS IIIB
April 1978	120 kV, 70 A, 0.02 sec on 10 x 40 cm Source, TS IIIB
June 1979	120 kV, 80 A, 0.5 sec, 1% Duty Factor, NBSTF System Operational
February 1980	120 kV, 60 A, 0.5 sec on TFTR 10 x 40 cm Source
March 1980	Closed-Loop Tracking Arc Modulator Proof-of-Principle Demonstration, NBSTF
October 1980	100 kV, 6 A, 5 sec Unregulated Accel Operation on TS IIIA
October 1980	Start NBSTF Upgrade of NBSTF to 170 kV, 65 A, 30 sec, 10% Duty
January 1981	Completed NBSTF-TFM Upgrade to 120 kV, 65 A, 1.5 sec, 1% Duty Factor

controllers at the 4160 V level. The arc PS will have phase-controlled SCR's in the HV-isolated secondary circuit and a new transistorized shunting-type arc modulator with a feedback-controlled regulating ability. This hardware is now being purchased or designed. Experience gained from this equipment will be valuable to other programs and would have been to ZEPHYR.

3.0.3 General Description

The major PS's required for operating the NBIS are shown in the block diagram Figure 3.0.3-1; there are a total of eighteen such systems associated with ZEPHYR (six beamlines, with three sources each). The arc and filament supplies are used to produce the plasma which is the source of positive deuterium ions (see Section 2.2.1). The accel PS is used in forming and accelerating the beam (see Section 2.2.2). The suppressor PS is used to protect the source and the accelerator grids from backstreaming electrons, coming primarily from the neutralizer, and the magnet PS is used for removing unneutralized ions from the beam (see Section 2.2.4). The remaining major power supply component is a "core snubber," whose purpose is to protect the accelerator structure from the PS stored energy in the event of sparkdown.

By far the largest of these supplies is the accel PS which must supply up to roughly 10 MW of beam power per source. Because of the large power demands of (eighteen) such sources, IPP decided that the accel PS power, along with that of the suppressor PS, should be supplied by the same motor-generator (MG) set which was used to power the

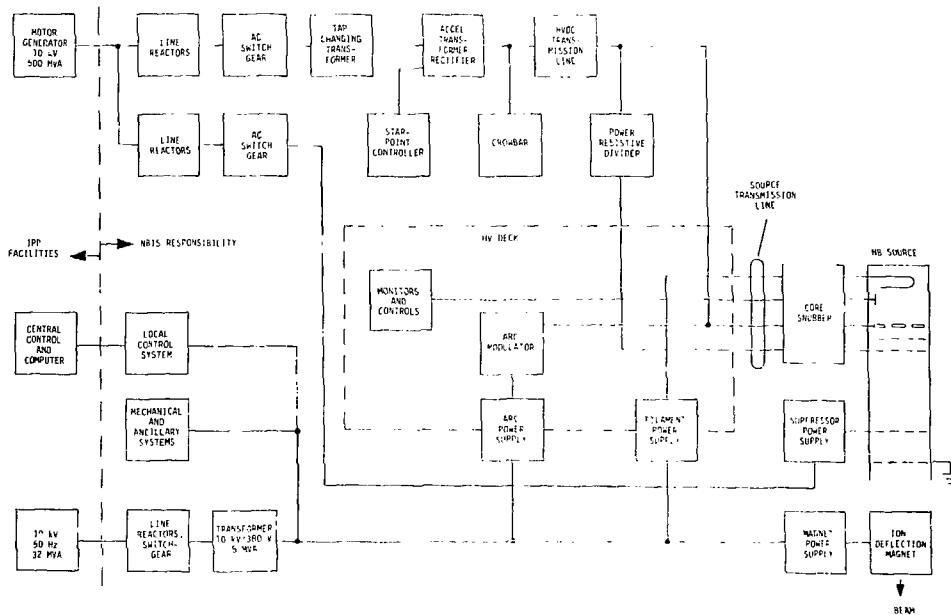

Fig. 3.0.3-1 Electrical systems block diagram

XBL 814-9242

ZEPHYR toroidal field (TF) coils. This imposes the additional design constraint on these supplies that they be able to operate using an input power source of variable frequency.

A second major design constraint on the NBIS supplies arises from the need for high power switching. This is in part due to the fact that the beam consists of finite-length pulses, but is also due to the need to interrupt the power from the accel PS in order to prevent the energy stored in it from damaging the accelerator structure during occasional sparking.

The operating sequence for a typical beam "shot," including the switching sequences associated with sparkdown, is shown in Table 3.0.3-1. In conventional parlance, a shot is defined as the entire period during which beam is requested, either for injection or conditioning purposes. This is to distinguish it from a "pulse", which is the period between turn-on and turn-off. Because of interrupts during sparkdown, a shot may consist of more than a single pulse. The "notching" of the arc effects a reduction in plasma density in the ion source (and hence beam current) to maintain approximate "perveance match" and reasonable ion optics during the turn-on of the accel PS. The other unusual feature in the operating sequence is the filament PS "step" command, whose purpose is discussed in Section 3.4.1.

A detailed listing of overall PS design requirements and constraints imposed by ZEPHYR is given in Section 3.1; following this we list a detailed set of specifications for each of the power

Table 3.0.3-1

APPROXIMATE TYPICAL OPERATING SEQUENCE (INCLUDING SPARKDOWN)

<u>Time</u> <u>(sec)</u>	<u>Event</u>
-90.00 (Typical)	Accel Primary Tap-Changing Started
- 4.00	Magnet PS ON
0.00	Receive <u>FIRE Command</u> From ZEPHYR
0.00	Accel Primary Contactor CLOSE Command
0.00	Ion Deflection Magnet PS ON
0.00	Filament PS ON
1.48	Gas Valve OPEN Command
1.49	Filament Step Command
1.52	Arc PS ON
1.60	Arc Notch Command
1.60 (Beam On)	Accel Primary Controllers ON
1.60	Suppressor PS ON (Slaved to Accel)
2.00 (e.g.)	<u>NB Source Spark</u>
2.00 (Beam Off)	Crowbar Command
2.00	Accel Primary Controllers OFF
2.00	Suppressor PS OFF
2.000	Divert Arc Current Gate ON
2.005	Divert Arc Current Gate OFF
2.012	Arc Notch Command
2.012	Accel Primary Controllers ON
2.012 (Beam On)	Suppressor PS ON
3.10 (Beam Off)	<u>End of Pulse</u> ; Crowbar Command
3.10	Accel Primary Controllers OFF
3.10	Accel Primary Contactor OPEN Command
3.10	Suppressor PS OFF
3.10	Divert Arc Current Gate ON
3.10	Arc PS OFF
3.10	Filament PS OFF
3.10	Magnet PS OFF
3.11	Gas Valve CLOSE Command

supplies as proposed by LPI. A discussion of primary power sources is presented in Section 3.2. Section 3.3 describes the accel PS (supplemented by a detailed circuit description given in Appendix C), and the remaining supplies are described in Section 3.4. Section 3.5 describes the design of the core snubber.

3.1 Design Specifications

3.1.1 ZEPHYR Requirements

A list of parameters relevant to the design of the ZEPHYR power supplies, as excerpted from the ZEPHYR ICD (see Appendix A), is given in Table 3.1.1-1. Included in the table are not only the power supply performance specifications, but also constraints due to such factors as motor-generator performance and space limitations. In the case of the accel PS, the current-voltage requirements are based on the fact that operation will be restricted to deuterium beams.

3.1.2 Proposed Neutral Beam Power System Specifications

The proposed NB power system specifications are listed in Table 3.1.2-1. A prudent margin of reserve capability over and above the requirements stated above has been incorporated into the specifications. For the filament and arc supplies, this is in fact necessary to permit proper output regulation. Of particular note is the 5 sec pulse width rating. This resulted from two considerations: first, an informally-expressed interest by IPP in possible longer pulses in the future; and second, the realization that as long as the duty cycle remains unchanged, the cost difference between a 1.5 sec and a 5 sec pulse capability is essentially negligible.

Table 3.1.1-1

ZEPHYR REQUIREMENTS AND CONSTRAINTS

Total Neutral Power to Plasma Target, Maximum	≥ 25 MW
No. Shots With ≥ 25 MW to Target	75%
Availability	$> 80\%$
Accelerating Voltage	≥ 160 kV
Voltage Regulation (Slow Variations), Pk-Pk	$\leq 2\%$
Voltage Ripple, Pk-Pk, Design Goal	$\leq 4\%$
Voltage Risetime (0 - 90%)	≤ 10 msec
Voltage Risetime (0 - 97%), Design Goal	≤ 250 msec
Voltage Resolution, 40 to 160 kV, Maximum	≤ 10 kV
Nominal Pulse Width, Maximum	1.5 sec
Duty Cycle, Maximum	1.25%
Simultaneous and Sequential Firing Modes	Required
Minimum Time Difference Between Sequential Source Firings	≤ 15 msec
Individual, Independent NB Source Control and Firing	Required
Emergency Beam-Stop Time	≤ 100 μ sec
Turn-off Requirements	Same as for Turn-on
Maintenance Interval for Components	10^3 shots
Component Lifetime (Except Source Filaments)	$\geq 2 \times 10^5$ shots
Filament Lifetime	TBD
Motor-Generator (M-G) Supply Voltage	10 kV
M-G Voltage Regulation, Long-Term	$\pm 1\%$
M-G Voltage Droop for 240 MVA Pulse Loading	$\leq 10\%$
M-G Voltage Recovery Time to $\pm 1\%$ Following 240 MVA Pulse Load	≤ 250 msec
M-G Flywheel Stored Energy, Maximum	5.2 GJ
M-G Output Frequency Range	78 to 110 Hz
M-G Short Circuit Current, Maximum	300 kA
Available Auxiliary Power at 220 V, 1 ϕ and 380 V, 3 ϕ , 50 Hz	5 MVA
Available Outdoor Area for PS Equipment	2400 m ²
Available Basement Area Under Beamlines for PS Equipment	90 m ²
Available Main Floor Area Near Beamlines	900 m ²
Outdoor - Type Large Transformers, Bushings, Switchgear	Preferred

Table 3.1.2-1

NB POWER SYSTEM SPECIFICATIONS
(Per NB Source, Except As Noted)

Accel PS

Voltage (V_{acc})	
Operating Range	40 to 176 kV
Regulation, Pk-Pk	$\leq 2\% V_{acc}$
Ripple, Pk-Pk	$\leq 4\% V_{acc}$
Risetime (0 - 90%); Falltime (90% - 0)	≤ 10 msec
Risetime (0 - 97%); Falltime (97% - 0)	≤ 250 msec
Resolution (With 33 Taps,	~ 4.1 kV
Current (I_{acc})	
Operating Range	0 to 60 A
Turn-off Time to $\leq 1\%$ After Fault	≤ 10 μ sec
Interrupt Duration After Fault	5 to 100 msec
Interrupts Allowed In One Shot	1 to 10
Pulse Width, Adjustable	1 msec to 5.0 sec
Pulse Repetition Rate, Adjustable	1 per 2 Minutes, Max.
Duty Cycle, Maximum	1.25%
Lifetime at Max. Output (Including Interrupts)	$\left\{ \begin{array}{l} 2 \times 10^5 \text{ Shots} \\ 2 \times 10^6 \text{ Pulses} \end{array} \right.$
AC Primary Voltage	10 kV, 3 ϕ
AC Primary Frequency Range	78 to 110 Hz

Gradient Grid PS

Voltage (V_{gg})	
Operating Range, Adjustable	0.75 to 0.90 V_{acc}
Adjustment Resolution	$\leq 0.01 V_{acc}$
Current (I_{gg})	
Range Anticipated	0 to ± 1 A
Turn-off Time & Interrupt Duration	Same as V_{acc}
Pulse Width and Repetition Rate	Same as V_{acc}
Duty Cycle, Maximum	1.25%
Power Resistive Divider Current, Maximum	5 A

Table 3.1.2-1 (cont'd)

NB POWER SYSTEM SPECIFICATIONS
(Per NB Source, Except As Noted)

Suppressor Grid PS

Voltage (V_{supp})	
Internal Supply, At Full Load, Maximum	-7.5 kV
Output Operating Range	-2.0 to -6.0 kV
Adjustment Resolution	0.5 kV
Regulation (Over 0 - 30 A Range), Pk-Pk	$\leq 10\% V_{supp}$
Ripple, Pk-Pk	$\leq 10\% V_{supp}$
Turn-on Delay Plus Risetime (Slaved to V_{acc})	$\leq 5 \mu\text{sec}$
Current (I_{supp})	
Operating Range	0 to 30 A
Turn-off Time and Interrupt Duration	Same as V_{acc}
Pulse Width and Repetition Rate	Same as V_{acc}
Duty Cycle, Maximum	1.25%
AC Primary Voltage	10 kV, 3 ϕ
AC Primary Frequency Range	78 to 110 Hz

Filament PS

Number of Isolated Filament PS Rectifiers	30
Voltage (V_f , Common Adjustment for All Filaments)	
Internal Supply, At Full Load, Maximum	14 V
Output Operating Range (At Fil. Terminals)	8 to 11 V
Regulation (For Slow Variations)	$\leq 0.5\% V_f$
Ripple, Pk-Pk	$\leq 1\% V_f$
Adjustment Resolution	$\leq 0.5\% V_f$
Step Depth, Adjustable	$\leq 15\% V_f$
Current (I_f)	
Total, Maximum	3750 A
Inrush/Operating Ratio	3.0 \pm 0.3
Individual Fil., $I_f/30$, Maximum	125 A
Pulse Width, Maximum	7 sec
Pulse Repetition Rate, Maximum	1 per 2 Minutes, Max.
Duty Cycle, Maximum	5.83%
AC Primary Voltage	380 V, 3 ϕ
AC Primary Frequency	50 Hz

Table 3.1.2-1 (cont'd)

NB POWER SYSTEM SPECIFICATIONS
(Per NB Source, Except As Noted)

Arc PS

Voltage (V_{arc})	
Internal Supply At Full Load, Maximum	88 V
Output Operating Range (At Arc Terminals)	20 to 85 V
Open Circuit, Maximum	185 \pm 15 V
Current (I_{arc})	
Operating Range	150 to 1500 A
Regulation Plus Ripple (Fixed Resistance Load), Max.	1% Pk-Pk
Short Circuit/Operating Ratio At All I_{arc}	≤ 2
Resolution At All I_{arc}	$\leq 1\%$
Pulse Width, Maximum	6.0 sec
Pulse Repetition Rate, Maximum	1 per 2 Minutes, Max.
Duty Cycle, Maximum	5%
AC Primary Voltage	380 V, 3 ϕ
AC Primary Frequency	50 Hz

Arc Modulator/Regulator

I_{arc} Range	150 to 1500 A
Divert/Notch Current Range, I_{notch}	150 to 750 A
Falltime (I_{arc} to I_{notch})	≤ 100 μ sec
Divert/Notch Width Range	.00 μ sec to 10 msec
Arc Current During Rise (I_{notch} to I_{arc})	Approximately proportional to $V_{acc}^{3/2}$
Rise Curve-Shaping Adjustments, Minimum	24
Double Notches in Any Pulse, Maximum	20
Regulator Current Range	0 to 150 A
Regulator Closed-Loop Bandwidth	≥ 500 Hz

Table 3.1.2-1 (cont'd)

NB POWER SYSTEM SPECIFICATIONS
(Per NB Source, Except As Noted)

Magnet PS (Per Gap, Two Series Coils)

Voltage Range At PS Terminals	≤ 15 V to 50 V Max.
Current	
Operating Range	≤ 40 A to 100 A Max.
Regulation and Ripple, Maximum	$\leq 1\%$ Pk-Pk
Duty Cycle	100%
Programmable	Required
Programmed Setting Accuracy	$\leq +1\%$
AC Primary Voltage	220 V, 1 ϕ
AC Primary Frequency	50 Hz

Stored Energy And Core Snubber

Maximum $1/2 CV^2$ Energy on NB Source Side of Core Snubber	3 J
Maximum $1/2 CV^2$ Energy on PS Side of Core Snubber	15 J
Maximum Fault Current Permitted by Core Snubber Over and Above Operating I_{acc}	300 A

General (For Total NBPS)

Number of NB Sources	18
Availability	$> 80\%$
Auxiliary Power Required at 220 V, 1 ϕ and 380 V, 3 ϕ	≤ 5 MVA
M-G Power Required at 10 kV, 3 ϕ	206 MVA, P.F. ≈ 0.95
Individual, Independent NB Source Control and Firing	Provided
Simultaneous and Sequential Firing Modes	Provided
Minimum Time Difference Between Sequential Source Firings	≤ 15 msec
Emergency Beam-Stop Time	≤ 100 μ sec
Maintenance Interval for Components	$> 10^3$ shots
Component Lifetime (Except Source Filaments)	$\geq 2 \times 10^5$ shots
Filament Lifetime	TBD

The specifications given are for a "double magnetic bucket" type of NB source with isolated filaments which produces 50 A of extracted deuterium ion current at 160 kV.

3.2 Primary Power Sources And Loading

3.2.1 Source and Feeder Arrangement

The arrangement for the source and distribution of ac primary power to the NB power systems is shown in the one-line diagram of Figure 3.2.1-1. A 500 MVA MG supplies 10 kV, 3 ϕ power to the TF coil power supplies and the NB accel and suppressor power supplies. Also available for NBIS primary power is 5 MVA of 10 kV, 50 Hz power from a 32 MVA bus.

It is desirable to supply fixed-frequency power to the arc and filament PS's in order to minimize their regulation and ripple-filtering burden. This, and the 5 MVA constraint on available 50 Hz power, are the reasons for distributing the loads as shown. Since the suppressor PS's have only modest regulation requirements, they can tolerate the short-term line voltage drops expected on the 10 kV MC bus. The line reactors are necessary for limiting available short circuit currents to the rated interrupting capacity of the various PS circuit breakers.

All of the auxiliary PS's have 380 V, 3 ϕ ac primaries except the eighteen magnet PS's whose primaries are rated at 220 V, 1 ϕ . Their loading will be balanced with 6 PS's connected between each of the three 380 V lines and the neutral. The latter is carried on the 4th wire of the 380 V, 3 ϕ feeder.

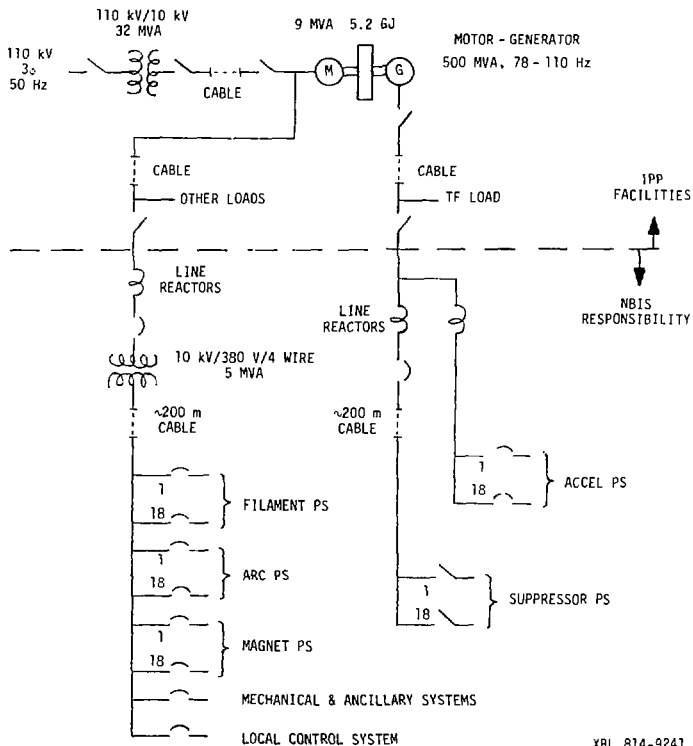

Fig. 3.2.1-1 Primary power source and distribution

3.2.2 Load And Power Factor (PF) Summary

Table 3.2.2-1 summarizes the loads and their power factors. In making these estimates, appropriate factors have been included for such effects as commutation, harmonic distortion, exciting currents, line reactor and feeder impedance, and the resistive losses in transformer windings, rectifier diodes, and dc output leads.

3.2.3 Motor Generator Considerations; Output Frequency

The flywheel energy storage for the MG is 5.2 GJ. Its drive motor is rated at 9 MW. Allowing for the motor power input plus friction and windage losses, the worst-case TF + NB loading vs time is shown in Figure 3.2.3-1.

At the time of the NB pulsing, the TF coil PS is in a phased-back and bypassing mode, maintaining the TF coil current. As the windings heat up, resistive losses increase the TF primary power requirement from approximately 120 to 140 MVA during the NB pulse. The time-integrated power load and time-dependent generator output frequency are also plotted in Figure 3.2.3-1. This shows that the worst-case frequency-change during NB pulsing is approximately 5 Hz as the frequency falls from 96 to 91 Hz. At various times during operations or NB source conditioning, any or all NB sources may be operated and the TF load may be anything from zero to the maximum value shown in the figure. Therefore, the general specifications for the NB power systems must be met while the primary supply frequency is any value within the range of 78 to 110 Hz.

Table 3.2.2-1

PRIMARY LOADING AND POWER FACTOR SUMMARY

(18 NB Sources And Power Supplies)

	<u>Worst-Case, Full Load</u>		
	P_{real}	Min. PF	P_{total}
	<u>(MW)</u>	_____	<u>(MVA)</u>
<u>M-G Loads</u>			
Accel PS	191	0.95	201
Suppressor PS	<u>4.1</u>	0.95	<u>4.8</u>
	195.1	0.95 (net)	205.8
<u>380 V, 3ϕ, 50 Hz Loads</u>			
Filament PS	1.35	0.93	1.45
Arc PS	2.56	0.86	2.97
Magnet PS	<u>0.09</u>	0.81	<u>0.11</u>
	4.00	0.89 (net)	4.53
LCS			
Mechanical Systems			0.47
Ancillary Equipment			_____
			5.00

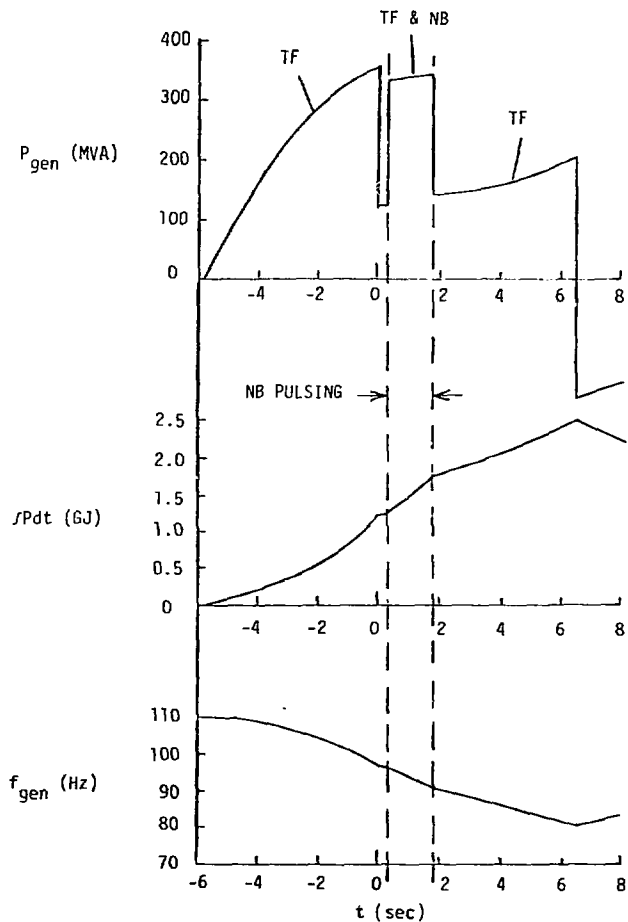

XBL 814-9240

Fig. 3.2.3-1 Generator loading and output frequency

As indicated in Table 3.1.1-1, the MG output voltage is nominally regulated to $\pm 1\%$. However, simultaneous full-load pulsing of all NB PS's will cause a rapid voltage decrease of $\leq 10\%$ followed by a 250 msec recovery period for the voltage to rise again to the nominal regulated range. The 0 - 97% accel risetime requirement specified by ZEPHYR permits V_{accel} to simply follow this voltage variation, dropping and recovering proportional to the MG output voltage. As discussed later, the arc modulator causes I_{arc} to track this V_{accel} variation correctly so that proper beam optics are maintained.

3.3 Accel/Gradient Grid Power Supply

3.3.1 Introduction

The major PS of an NB power system is the accel PS (which also supplies the gradient grid voltage, through the use of a power resistive divider). The earliest such supply built at LBL had a 20 kV, 10A, 10 msec, 1% duty capability; the most recent is a 170 kV, 65 A, 30 sec, 10% duty system now being assembled. Qualitative changes in supply design have accompanied the increase in capability. For example, at voltages above 40 kV, the serious difficulties in using tubes as HVDC series switches prompted us to choose alternative approaches. Because tight regulation and ripple requirements were specified, shunt-regulation was provided and solid-state (series SCR) assemblies were developed as series HVDC switches. These switches have proven extremely reliable and trouble-free. One such accel PS consists of a 1.2 MJ capacitor bank supplying 120 kV, 80 A for approximately 40 msec to a NB source. This supply is switched,

interrupted (several times during a shot if necessary), and regulated entirely by SCR circuitry. We have come to believe in the reliability and overall economy of the solid-state approach, even in large HVDC applications. We note that the power companies apparently agree; there are SCR-based converters in service in large installations operating at 500 kV DC.

Since 1977, we have advocated the relaxing of certain NB source electrical specifications (e.g., regulation, ripple, and risetime) realizing that large gains in the areas of cost and reliability could result from reduced PS complexity. In particular, we have felt that as a general rule, it is technically wiser, as well as more economical, to minimize the amount of circuitry in the HVDC secondary. Permitting an accel risetime of 10 msec, e.g., can permit all ON/OFF switching to take place in the ac primary circuit, eliminating the need for all HVDC switching except for a crowbar.

In choosing the configuration for the accel PS, we have taken advantage of the generally relaxed specifications provided by IPP and incorporated the principles discussed above. Also strongly influencing the choice is our experience with arc modulators and various existing hardware designs for them. With this experience in hand, we feel that, given a regulated ac supply line, there is no need for a regulated (i.e., modulated) accel supply.

We are in fact now operating the accel PS for our long-pulse (5 sec) 120 kV test stand in an unregulated mode. (Our power line is long-term regulated to a nominal +1%; at this level of ac regulation, we have been able to achieve satisfactory NB source operation even

without using a tracking arc modulator.) Additionally, we have used electronic primary controllers in several high-power systems. (Earlier designs employed ignitrons and diodes; recent ones have SCR's.)

3.3.2 General Description And Block Diagram

In this section, a general description of the accel PS is presented along with a block diagram. A detailed technical explanation of the circuit is given in Appendix C with reference to a simplified schematic diagram.

The block diagram of the proposed accel PS is shown in Figure 3.3.2-1. The only control component in the high voltage circuit is the crowbar. This is triggered when a NB source sparks, diverting current from the NB source while the primary is opened by the star point controller (SPC). The latter is the heart of the supply and performs all of the necessary functions of pulse ON/OFF switching and interrupting, synchronized ON-switching, risetime control, and ripple filtering. The supply is unregulated and requires no large RC compensation network or ripple-filters in the HVDC secondary. The latter constitutes a significant saving in required floor space and eliminates potential problems associated with HVDC stored energy.

For each accel PS, the rectifier transformer, diode rectifiers, and RC snubber networks share a common oil-filled enclosure outdoors, approximately 200 m from the tokamak. The rectifier stacks and snubbers are to be configured in modules easily removed for inspection or maintenance. A HVDC cable, inside metal conduit, conducts the

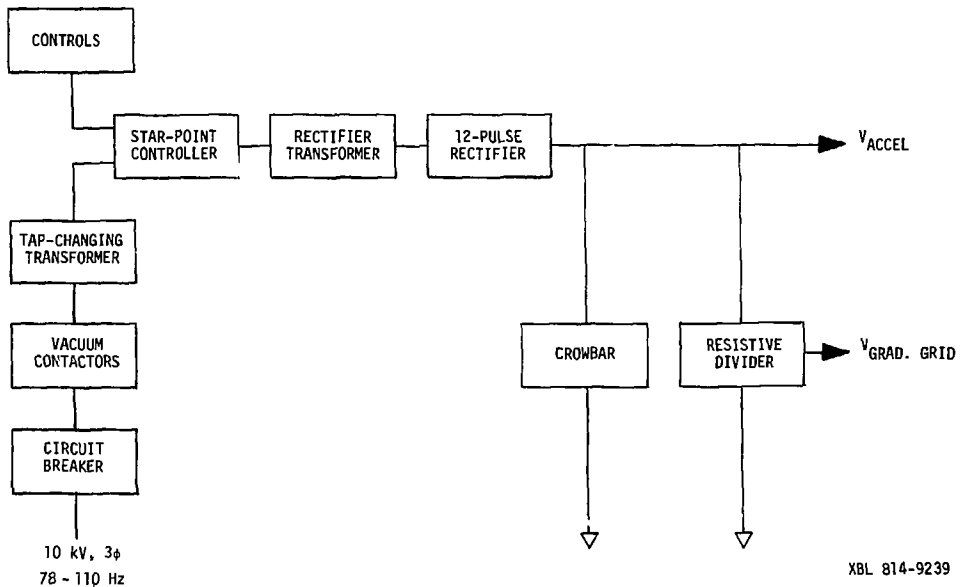

Fig. 3.3.2-1 Accel power supply block diagram

accel power to a nearby crowbar cabinet and from there to the main building basement, where it connects to the hot deck and gradient grid power divider.

The arrangement of the outdoor accel PS components, described above, has the major advantage of keeping all primary and HVDC secondary connections and components entirely enclosed in grounded tanks, cabinets, or conduits. There are no HV bushings or terminals exposed to possible lightning discharges. This, in turn, results in relatively large savings in rectifier transformer costs since a significantly reduced Basic Impulse Level (BIL) specification is now permissible. (The magnitude of this specification strongly influences transformer cost.) The oil-filled enclosures will have a slightly-pressurized nitrogen "blanket" over the oil. This continually excludes moisture and eliminates the possibility of generating explosive gas mixtures in the event there is internal sparking.

Vacuum contactors will close/open for each 1.5 sec ON/OFF sequence. These will provide a step-start action for resistively limiting the inrush current to the tap-changing transformer, thereby extending its life. Opening these after each shot minimizes the excitation time of the tap-changing transformer and SPC, and eliminates the possibility of accidentally producing accel voltage during control "glitches" or other malfunctions.

The tap-changing transformer is used to vary the output voltage. It has a 33 step tap-changing mechanism, which produces a V_{acc} adjustment increment of approximately 4.1 kV per tap over the required 40 to 176 kV range.

The SPC receives its commands from the local control system (LCS) and various monitoring and detecting circuits. The synchronized ON-switching mentioned in the previous section refers to a need to properly time the accel turn-on with respect to the primary ac waveform. This is a simple control requirement and comes about because there is no HVDC switch in the secondary, and because of the 10 msec risetime requirement.

Because of the latter requirement, a step-start excitation of the rectifier transformer cannot be used, since it cannot be effectively implemented in a manner that is compatible with a 10 msec output risetime. Moreover, randomly-timed full-voltage excitation of the rectifier transformer primary windings (a consequence of on/off switching in the primary circuit, rather than the secondary) would frequently result in output pulses which look like the one shown in Figure 3.3.2-2 (a). Oscillations such as those shown in the figure cannot be tolerated since their damping time constant is determined by the L/R ratio of the system, and this can easily exceed 100 msec in large power supplies. The oscillations are a result of one of the transformer core legs being driven into saturation at the time of excitation because the flux in that core leg had been left "high" (say) at the end of the previous shot.

To overcome this problem, the controls will include circuitry to "remember" the point in the primary sinusoidal waveform where a pulse ends or an interrupt occurs (i.e., when a NB source sparks). The next pulse, or the restart after an interrupt, will be made to start at the instant the line voltage polarity, magnitude, and "direction" match

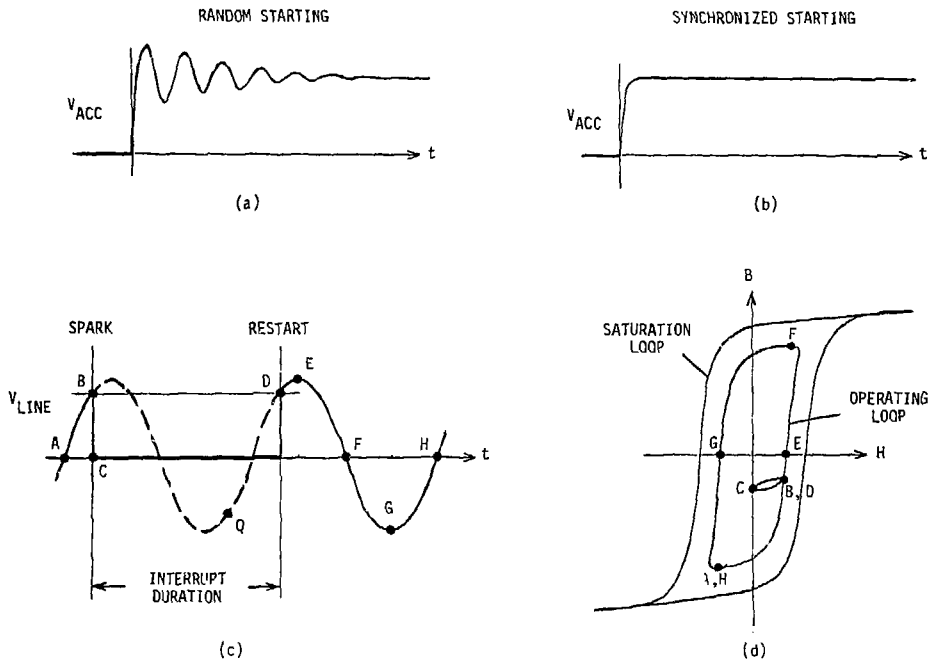

Fig. 3.3.2-2 Starting transients and magnetics

XBL 814-9238

the values which existed at the time of the prior turn-off. Figures 3.3.2-2 (c, d) show the relation between the input waveform and the core-material B-H loop, and illustrate the effect of synchronous turn-on on the loop, as well as on the V_{acc} waveform (Figure 3.2.2-2 b). In the case shown, a NB spark occurs at B and the restart occurs at E. The B-H loop path indicates that saturation is avoided in this case. If, however, the restart had been timed to occur at the point Q of the sine wave, there would likely be sufficient volt-seconds available during roughly the first half cycle to swing the iron flux-state from point C on the B-H loop to positive saturation.

3.4 Auxiliary Power Supplies

Time did not permit us to study and design the auxiliary PS's in depth. However, certain tentative conclusions have been reached. These are summarized in this section. (Refer to specifications in Table 3.1.2-1.)

3.4.1 Filament Power Supply

The filament PS consists of 30 isolated well-filtered sources of 8 to 11 V dc, 125 A power floating at V_{acc} potential. An isolation transformer provides HV-isolated primary voltage to one or more filament rectifier transformers located on the HV deck (see Figure 3.0.1-1). These have multiple secondary windings which connect to rectifiers and filters.

The isolation transformer receives its power from a 380 V, 3 ϕ standard thyristor controller. This controller performs the functions

of ON/OFF switching, output voltage adjustment and slow regulation, and filament stepping. The latter refers to a requirement of the double-bucket NB source. When the arc is turned on, arc current flowing through the filaments can cause them to overheat, causing erratic operation and shortening their life. The filament PS primary excitation must be reduced, or stepped, in synchronism with arc turn-on in order to maintain constant filament emission and achieve stable operation.

The per-unit impedance of the supply is approximately 33%, in order to limit the current inrush to cold filaments to $\leq 300\%$ of normal I_{fil} .

3.4.2 Arc Power Supply

This supply is essentially a shorter pulse-width, shorter duty-cycle version of the 30 sec, 10% duty factor arc PS now under construction, which will be used to power the 65 A sources for NBETF. Like the filament PS, it is located on the HV deck; a single transformer serves as both the isolation and rectifier transformer. It includes a 12-pulse phase-controlled thyristor bridge rectifier in the HV-isolated secondary. Included in the HV deck is a shunting-type arc modulator which has a $\sim 10\%$ feedback-controlled current-regulating range. Coarse current-ranging is controlled by switched line reactors in the 380 V, 3 ϕ primary lines.

3.4.3 Suppressor Power Supply

This supply must be slaved to V_{acc} ; i.e., it should always be turned on and off at the same time as V_{acc} . The delay

between the time V_{acc} exceeds 3 kV and the time in which this supply turns on will be made as short as possible, e.g., 1 to 2 μ sec. The sum of this delay and the 0 - 90% risetime must not exceed 5 μ sec.

The supply is switched by a 4CW 250,000 tetrode. A rather large plate dissipation rating is required to satisfy the minimum-output case. The tube can then conduct 30 A with a 5.5 kV anode voltage. It is possible to select V_{supp} in 500 V increments over a range of -2 kV to -6 kV. A $\leq 10\%$ voltage regulation can be maintained over a 0 to 30 A load current range. An adjustable screen voltage supply permits the selection of a short-duration current limit value between 0 and about 50 A.

The equipment is to be located outdoors, perhaps 200 m or so from the NB sources. The V_{supp} feed cables need proper transient terminations near the experiment. At this location, also, diode strings are to be located for clamping transient positive voltage excursions which occur when the NB source sparks.

The 10 kV, 3 ϕ suppressor supply bus is fed through current limiting reactors and a circuit breaker. The individual suppressor PS's incorporate ac primary vacuum contactors and output dc grounding switches.

3.4.4 Magnet Power Supply

This supply provides power to the ion deflection magnet in the vacuum chamber. The nominal magnet design requirement compatible with a 40 to 176 kV accel PS range is ~ 21 V, 40 A to ~ 42 V, 80 A. Current variations from regulation and ripple must fall within a 1% pk-pk band.

Programmable 5 kW PS's rated at ≤ 15 V to 50 V, 100 A maximum and having 220 V, 1 ϕ primary excitation satisfy the above requirements. Supplies meeting these specifications are commercially available at reasonable cost. Eighteen units can be symmetrically loaded (line to neutral) onto the 380 V, 3 ϕ supply bus.

The programmable feature is necessary in order to be able to accurately preset the magnet excitation, before a shot, to the value consistent with the V_{acc} requested for that shot. An adjustment accuracy of $\leq 1\%$ is desirable to keep the deflected ion beam properly aimed toward the ion dump. The LCS is responsible for checking the proper I_{mag} setting just before the shot and for inhibiting firing in the event that it is incorrect.

3.5 Core Snubber

3.5.1 General

This important component consists of a stack of tape-wound cores and is used to limit the $1/2 CV^2$ stored energy available to participate "promptly" in a NB source spark, and also to limit the transient peak accel current during a NB spark to $\lesssim 300$ A over and above the normal operating value. The snubber must be located as near to the NB source as possible in order to meet the requirement for ≤ 5 J stored energy on the NB source side of the snubber. All leads which connect to the NB source, including control and monitor leads, the gradient grid power feed, and arc and filament supply leads, must thread through the stack of cores. The entire assembly floats at V_{acc} potential. The snubber circuit and its physical arrangement is shown in Figure 3.5.1-1.

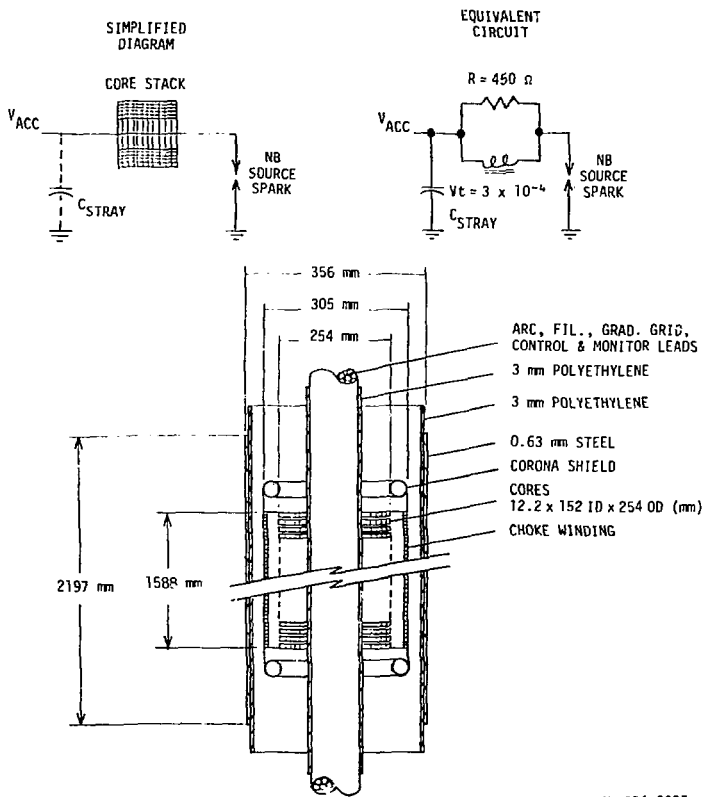

XBL 814-9237

Fig. 3.5.1-1 Core snubber circuit and assembly

The core flux is reset by a current-bias circuit fed from the filament PS. This circuit requires a choke in order not to short out the core stack during the transient period when it is to be active. The choke must be capable of transiently sustaining an end-to-end voltage equal to the maximum V_{acc} . To minimize capacitance to ground (counted in the $1/2 CV^2$ total), the choke coil is located outside of and concentric with the core stack. At a flux-reset bias current of ~ 60 A, however, the choke produces a significant external magnetic field. Analysis shows this is ~ 100 Gauss at the ends of the coil, and ~ 8 Gauss 0.5 m away, on axis, approximately the distance to the nearest NB source surface. Since stray magnetic fields at the NB source must be < 1 Gauss, magnetic shielding near the snubber and choke is required. A thin-walled steel cylinder which is outside of, longer than, coaxial with, and insulated from the choke coil can satisfy the need in a simple manner. It may be necessary to implement this with several in-line cylindrical sections separated and insulated from each other. This would be done to reduce the net end-to-end capacitance of the snubber assembly. A relatively thin dielectric barrier can be used to aid in transient voltage-holding. The corona shields at the ends of the choke windings are necessary to prevent corona from occurring during the 1 to $2 \mu\text{sec}$ that full V_{acc} voltage appears across the snubber.

3.5.2 Stored-Energy Analysis

Existing LBL NB sources have shown a tendency toward degraded voltage-holding when the "unsnubbed" $1/2 CV^2$ capacitively-stored energy between the core snubber and the NB source

exceeds approximately 5 J and the current in a spark exceeds a few hundred amperes. The capacitance to ground associated with the NB source and the proposed ZEPHYR arrangement of core snubber NB source connections has been analyzed for 160 kV operation. The contributions of these components to the total stored energy "budget" is summarized in Table 3.5.2-1.

Table 3.5.2-1
"Unsnubbed" Stored-Energy Summary

<u>Component</u>	<u>Stored Energy (J)</u>
Core Snubber	0.63
Connecting Cables & Sheet Conductors	0.41
NB Source (Internal)	1.25
NB Source (External)	<u>0.41</u>
Total	2.72

The above contribution from the core snubber is felt to be a conservative estimate. It is based on the assumption that only half of the capacitive energy associated with the core snubber is inadequately snubbed.

Reviewing the mechanical layout of the core snubber and NB source, it appears feasible to reduce the length of the sheet conductors which bring filament and arc current to the NB source. The reduction in stored energy thus achieved is estimated to be approximately 0.1 J, a rather small but still desirable savings. With this reduction, the 5 J stored energy limit can be met with an accel voltage well in excess of 200 kV.

4. CONTROL AND DIAGNOSTIC SYSTEMS

4.0 General Requirements

The ZEPHYR Control and Diagnostic System must

- (1) Allow the ZEPHYR Central Control System (ZCCS) to easily set the start time, duration, and voltage of each neutral beam (NB) pulse of every NB source.
- (2) Allow an operator to easily and safely bring each NB source to the point where it is ready to deliver beam to ZEPHYR. (This includes both the long "conditioning" phase of a new NB source and the short "warm up" necessary for a "cold" but conditioned source.)
- (3) Monitor long and short term behavior of the neutral beamlines to alert the operator to potentially damaging trends before any damage occurs.
- (4) Provide sufficient diagnostic information to allow operators, engineers, and physicists to rapidly determine the cause of any problems with a NB source or beamline.
- (5) Provide the required NBIS performance data to ZCCS after each shot.

In addition, the entire neutral beam injection system (NBIS) must be highly reliable (>75% availability), produced at a minimum cost, and completely operational in a relatively short time (four calendar years).

This chapter of the report details a control and diagnostic system which we feel meets all of the above criteria. It is an adaptation of the LBL-developed system used to control the TFTR Neutral Beam System Test Facility (NBSTF) and General Atomic's Doublet-III NB injectors.

The existing LBL NB control and diagnostic system was itself an outgrowth of earlier LBL-developed real-time accelerator control systems, and thus represents approximately 50 man-years of accumulated development in real-time control.¹⁻⁷

Since the ZEPHYR control and diagnostics system is a small iteration on the existing LBL NB system, equipment cost and delivery schedules can be specified with some confidence (the entire system is constructed from commercially available equipment⁸). The use of the proven LBL software minimizes the largest component of the system's cost, namely that of software development. Since the NBSTF and Doublet-III control systems have demonstrated excellent availability (>95% overall, >99% for the computer systems), have met or exceeded all of their original design objectives, and are well liked by their users, we have good reason to believe this is the best system solution for ZEPHYR.

In the following sections we discuss the hardware and software components of the neutral beam control system (NBCS). We start with a description of the primary transducers and controls, and then proceed to the data acquisition hardware, the computer system, the operator/NBIS interface, and finally, the software architecture. Because of the similarity of the proposed ZCCS to the existing NBSTF and Doublet-III systems, we have been able to incorporate a number of specific examples of both hardware and operating experience in our discussion.

4.1 Control System Architecture

A simplified block diagram of the entire NBCS is shown in Fig.

4.1-1. It consists of one medium scale mini-computer per beamline. All

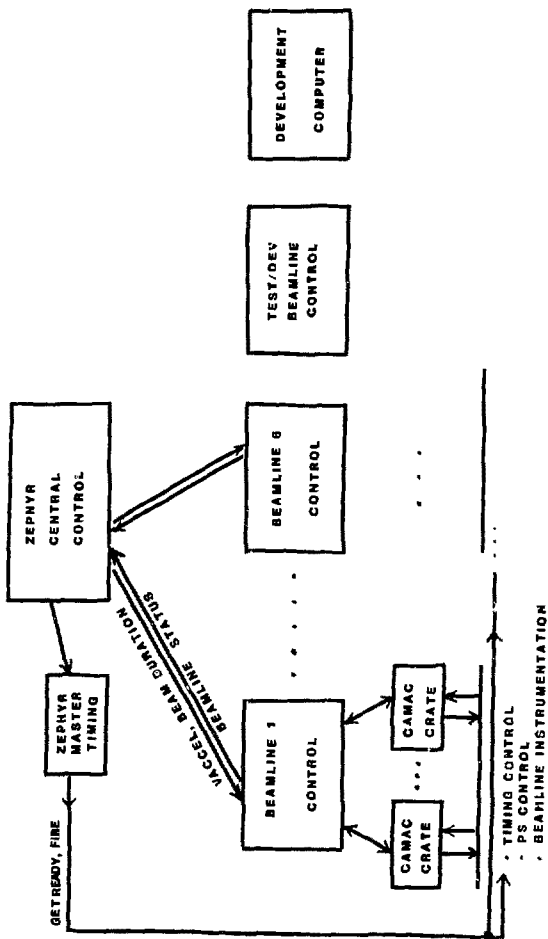

XBL 814-9190

4.1-1 Neutral beam controls and diagnostics

beamlines are identical (to minimize maintenance and development costs) and there is no communication among beamlines (to minimize the impact of a single beamline's failure). A few simple interface signals (discussed in Sect. 4.6) connect ZCCS to each beamline.

Each beamline computer is connected to the beamline instrumentation and controls via CAMAC crates and modules. In the absence of specific guidance from the ICD, we chose CAMAC (as opposed to a vendor supplied process I/O system) since it is an international standard for nuclear instrumentation and thus probably familiar to engineers and physicists working on both ZEPHYR and the ZEPHYR NBIS. Also, there are commercially available CAMAC modules to perform almost every function necessary for NB operation; we have found no vendor able to supply an equivalent range of non-CAMAC modules.

In addition to the computers for the injection beamlines, there will likely be a control computer for a test cell beamline (to be used for source conditioning and detailed diagnostic investigations of the NB systems) and a computer for software and hardware development. This last is frequently omitted in the name of "economy"; however, since the life-cycle costs of the control system will be dominated by the operating and programming costs, and lack of an available machine for development and test generally makes the programming take at least twice as long, the "economy" generally saves about a hundred thousand dollars of initial capital cost, but results in a development costs which are several times that.

Since all the computers are identical, either the test cell machine or the development machine can be used to run an injection beamline in

the event of a failure. The failure rates of mini-computers are very low - the NBSTF Modcomp Classic has had only one failure in its 2 year operating life - but the mean time to repair (MTTR) is often long: The single Classic problem took almost three weeks to isolate; the NBSTF development computer was used in its place while the problem was being worked on.

Figure 4.1-2 is a fairly detailed block diagram of a single beamline computer. Briefly, a typical shot sequence is as follows: Power supply (PS) setpoints are taken from the data base and output to the PS subsystem via CAMAC D/A converters. The CAMAC based timing system is triggered (from the local "Fire" button or the ZEPHYR master timing system) and it in turn sequences the PS's and various other hardware and software modules (the circled T's are the timing system outputs which trigger some sequence of events). Some software modules acquire experimental data and place it in the data base. The arrival of new data then triggers higher level software modules which display the data, fit it to models of the physical process involved, and search for alarms or anomalies or update models of the long-term source behavior. These new models, together with possible operator input, are then used to predict the correct PS setpoints for the next shot.

4.2 Instrumentation

A variety of instrumentation is necessary to keep a beamline operational and to identify and correct various failures.

4.2.1 Thermocouples

Thermocouples are required on virtually everything in

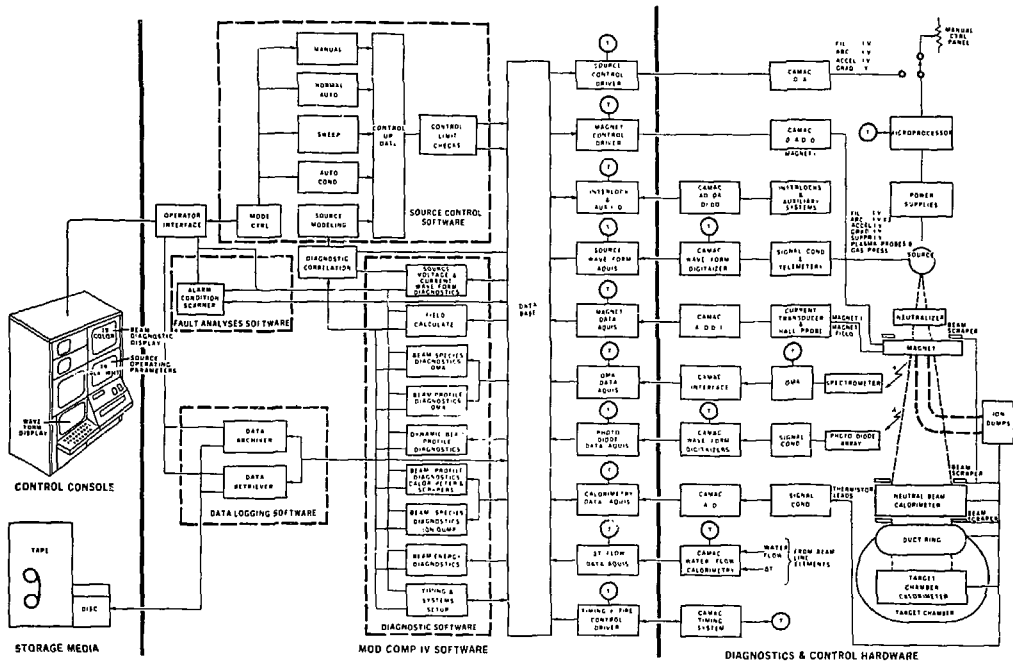

SOURCE DIAGNOSTICS AND CONTROL

Fig. 4.1-2 Block diagram of beamline computer system

XBL 803-8940

line-of-sight of the beam. A sufficiently dense rectangular array is required on the beamline calorimeter to allow a model to be fit to the temperature distribution. The results of this fit will be used in "tuning" the source for maximum power density and minimum beam divergence. They will be also used to center the beam so there is minimum power lost on the various apertures.

The ion dump requires a "cross" pattern of thermocouples with enough resolution in the vertical direction to adjust the magnet current so that all three energy components of the beam lie on the dump.

Each aperture requires top, bottom, left, and right thermocouples for use in correcting beam position during normal operation (i.e., injection into ZEPHYR).

4.2.2 Water Flow Calorimetry

Calorimetry is required on each aperture, ion dump, and calorimeter cooling water circuit. This diagnostic provides an energy inventory which directly measures the energy supplied to ZEPHYR. It is also the main indicator for degradation in the NB injector (e.g., a change in source perveance will cause an increase in divergence angle which will show up as too much energy deposited on one of the apertures).

4.2.3 Cryosystem Indicators

Such indicators, including Carbon-Glass Resistors (CGR), ion gauges, thermocouple gauges, and LN₂ and LHe level indicators, are needed on the cryopanel, dewars and transfer lines. The large cryosystem has a number of failure modes but catastrophic events can usually be prevented by adequate information. For example,

high ion gauge pressure in one of the chambers could indicate a leak or a failure to pump.

4.2.4 Electrical Signals

These signals consist primarily of various power supply and source voltages and currents, and serve a variety of functions. First, they are used as inputs to the source fault detector; secondly, they are the primary measure of all source characteristics, such as permeance, arc efficiency, filament resistance, etc.; finally, they serve as the usual diagnostic tool for investigating both single-shot failures and long term degradations.

The usual sensors are resistive dividers, current shunts, Hall probes, and current transformers. Because of the pulsed nature of the NBIS operation, the input data presented to the NBCS are necessarily in the form of time histories (i.e., waveforms) with bandwidths of at least 1 kHz, and in a few instances, 1 MHz.

Experience at NBSTF has demonstrated that the MTTR for an electrical problem (which constitute the bulk of the beamline problems) varies inversely with the number of monitors available. NBSTF monitors about 60 power supply and source waveforms, and it would be useful to look at several more.

Since certain signals are the primary indicator of source performance (i.e., I_{acc} , V_{acc} , I_{gg} , etc.) and large dividers and shunts have substantial gain and offset drift over relatively short times (< 1 day), at minimum these signals should have a computer controllable calibration system which calibrates as much of the signal path (transducer, cabling, signal conditioner, telemetry, digitizer, etc.) as possible.

4.2.5 Fault Detectors

Detection of such faults as sparks, overcurrents, etc., is necessary to prevent various electrical faults from damaging the source or power supplies. Most faults are defined simply by a given signal exceeding some preset threshold; the fault detector must then cause power to be temporarily removed from the source. However, post-shot analysis of faults requires that the type and time (to within about 1 microsecond) of each fault be available to the computer. For example, a gradient-grid-to-suppressor-grid spark is usually indicated by a fast dV/dt in V_{acc} . However, a source-grid-to-gradient-grid spark also has this fast dV/dt , but is accompanied by high gradient grid and suppressor currents. All three fault indications and their time of occurrence are needed to distinguish between the two types of events.

4.2.6 Safety Interlocks

These are required to protect people and equipment from mistakes and improper operation, e.g., firing with people in the high voltage area; attempting a shot with the filament power supply off, etc. Since the interlocks are the primary safety system, they should be simple and self contained. However, since a substantial portion of the machine turn-on time can be involved in making up the interlocks, complete information on interlock status should be available to the computer, so that missing interlocks can be flagged for rapid location and corrected.

4.3 Interface Hardware

With the exception of the water flow calorimetry, waveform

calibration system, and fault detector, all of the above instrumentation, up to and including the interface to the computer, is mass produced commercial equipment.

It should be noted that the NB environment contains both substantial electrical noise and high radiation fluxes. To avoid electronic equipment radiation damage and to simplify maintenance, all electronic equipment should be located outside the shielding walls. Since this results in long signal runs, all signal conditioners need to be true differential with high common-mode noise rejection.

4.3.1 Thermocouples

The thermocouples are type E (chosen for their temperature range and high output). They are buffered with individual amplifiers and brought into the computer through multiplexed, dual-slope integrating ADC's. Both the amplifiers and ADC's are available as CAMAC modules from a number of vendors (NBSTF and Doublet-III use Kinetic Systems KS-3540 amplifiers and KS-3510 ADC's).

4.3.2 Cryosystem Indicators

CGR's, ion gauges, and liquid level indicators are standard commercial products. The CGR's and level indicators interface through signal-conditioning pre-amplifiers and 12-bit CAMAC ADC's; the ion gauges, through 16-bit CAMAC digital input modules using the digital interface supplied by the ion gauge manufacturer.

4.3.3 Electrical Signals

The power supply and source electrical monitor signals

are conditioned (attenuated or amplified) to be in the +/- 5 V range acceptable to industrial process I/O hardware. The amplification is via commercially available instrumentation amplifiers; the attenuation, via compensated resistor networks. Signals which originate at ground level are run directly into commercially available waveform digitizers (NBSTF and Doublet-III use either 32 channel, 12 bit, 1 MHz Lecroy 8212's or 8 channel, 8 bit, 1 MHz Lecroy 2264's, depending on the time resolution necessary). Signals which originate at accel potential are conditioned, then brought down to ground level via commercial fiber optic telemetry (2 MHz bandwidth). The analog telemetry output is then fed into the appropriate waveform digitizer.

4.3.4 Safety Interlocks

The interlocks are done by a commercially available programmable sequencer (Doublet-II and Doublet-III use the Texas Instruments TI-6MF; TFTR, the Process Control Systems PCS-2000).

4.3.5 Sequencing and Timing Signals

All sequencing and timing, both hardware and software, is controlled by a CAMAC-based timing system. The timers have an external trigger input, which starts them timing, and two 24-bit registers. One register sets the time interval between the trigger and the timer "ON" transition, and the other sets the time from the "ON" transition to the "OFF" transition. These registers are used as presets for 24-bit down-counters counted out by a 1 MHz crystal clock, and can generate timing signals ranging from 1 microsecond to 2 days' delay and/or duration. NBSTF, Doublet-III, and TFTR use a CAMAC timer module developed by TFTR/LBL, but commercial equivalents are available.

4.3.6 Other Commercial Interface Hardware

In addition to the major diagnostic signals listed above, a variety of miscellaneous signals are interfaced via general purpose CAMAC D/A's, digital input modules, and digital output modules. These include a shot counter (two 16-bit digital inputs), setpoint requests from ZEPHYR Central (a 12-bit ADC), status report to ZEPHYR Central (a 16-bit digital output), etc. These are all stock CAMAC modules available from virtually any CAMAC supplier.

4.3.7 Non-commercial interface hardware

Of the non-commercial hardware, the water flow calorimetry is done by an LBL-developed, micro-processor-based CAMAC module which is currently being used by NBSTF and Doublet-III. Calibration is done by an LBL-developed calibration signal generator NIM module, currently being used by NBSTF and LBL TS-III. An LBL-developed prototype of the fault detector (lacking the computer readout of fault times) is in use at NBSTF and the version described here is in development for use in NBETF (an upgrade of the NBSTF facility).

4.4 Computer

Each beamline is controlled by a medium-sized mini-computer. The criteria for the computer are:

- It must be fast enough to perform all necessary processing for a shot at the maximum NB rep rate (one shot every two minutes).
- It must have enough disc storage for all of its programs, all of the large volume per-shot data (e.g., 512k bytes of waveform

data per shot) and all historic shot data required by the modelling, auto-conditioning and fault detection software.

- There must be sufficient main memory to perform several tasks in parallel (e.g., do a fit to the calorimeter thermocouple data while acquiring waveform data).

All of the available evidence demonstrates that the life-cycle costs of the control system will be dominated by the software costs. General industry results show that the software/hardware cost ratio is about 10 to 1, and our experience confirms this. The computer system should therefore be chosen to minimize the software cost. Some factors involved in this are:

- The computer should be fast enough that the bulk of the software can be done in a high-level language; this results in about five-fold productivity improvement.
- The computer should be large enough that it is only run at about 50% utilization of its bandwidth, main memory or disc (software costs tend to go up exponentially as any resource approaches saturation).
- The computer operating system should contain facilities for breaking down a problem into discrete units, sequencing those units, and managing communication among them.

In the last five years, a substantial body of literature on engineering software/hardware systems has developed. The bibliography mentions a few important papers.⁹⁻¹¹ The points above represent a distillation of this literature, blended with our own experience with real-time control systems.

The NBSTF and Doublet-III systems use Modcomp Classic computers with 512K words of memory, 3330-style 80M byte discs (1 per system), 75 ips tape drives (1 per system) and a medium speed line printer (1 per facility - usually on the development machine).

4.5 Operator Interface

The operator interface to the NB line is via a simple operator's console described in detail in Ref. 3. The console consists of three video graphics CRT's (2 color and one black and white), a transparent, touch sensitive panel over the face of the monochrome CRT, and two programmable knobs. The graphics CRT's have sufficient resolution (512 x 512) to show contour plots of the calorimeter temperature data, scope-like pictures of power supply waveforms, block diagrams of the beamline marked with interlock status, etc. The monochrome CRT and touch panel are used for all control functions. The touch panel has a resolution of 64 x 64 (about .5 by .5 cm squares). Controls, timing diagrams, mimic diagrams, etc., are "painted" on the CRT, and the operator simply touches the appropriate part of the screen to perform some function. Figure 4.5-1 shows a touch panel display used to control beamline timing and Fig. 4.5-2, a menu used to select displays of temperature data. Quantities which "human engineering" considerations require to be continuously variable are assigned via touch panel button to one of the knobs. A small display over the knob gives the name of the quantity it is adjusting and the current value (e.g., "V_{acc} = 75.8 kV"); turning the knob raises or lowers the value.

SHOT 26644

ARC & FIL TIMING

03/03/81 00:42

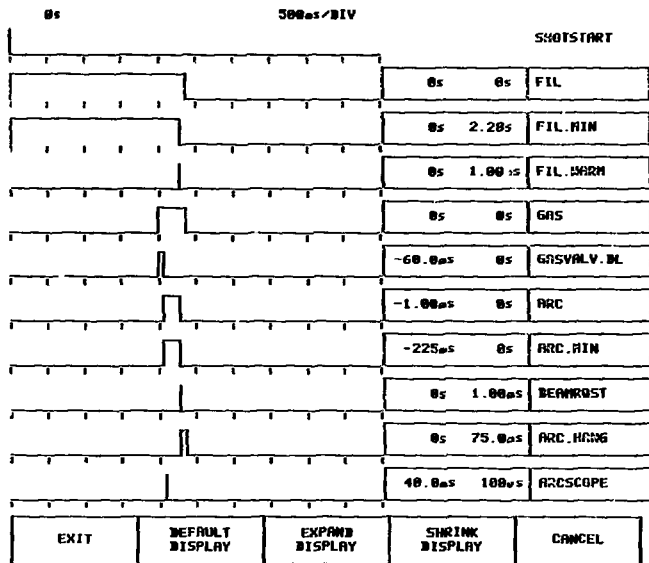
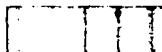

XBL 814-9251

Fig. 4.5-1 A typical touch-panel control display

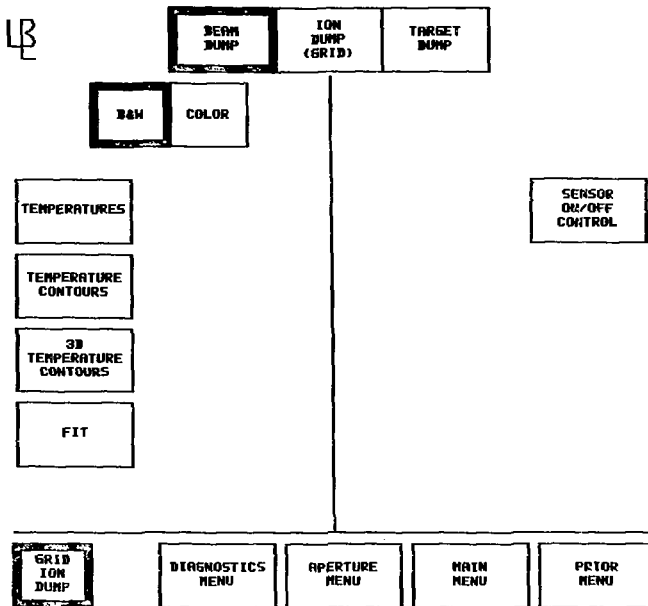

XBL 814-9252

Fig. 4.5-2 A typical touch-panel "menu" of diagnostic displays

This type of operator interface has been shown to have a number of advantages.^{3,12}

- It requires virtually no training time. One simply points at what one wants done.
- It is infinitely expandable. When a new device or function is added to the system, controls for it are simply a matter of painting the appropriate material on the CRT screen.
- It reduces operational errors. The only controls which ever appear on the screen are ones which are reasonable to use at the current phase of operation; hence it is virtually impossible for anyone to "accidentally hit the wrong button" and cause damage.
- It makes the machine simple to operate. The operator is usually dealing with an unambiguous picture of what is being operated (e.g., control of vacuum valves is done by painting a picture of the beamline vacuum tanks and valves; a valve is opened or closed by touching it). There is little possibility of confusing the names of things and operating on the wrong one by mistake.

Most of the diagnostic and control information is in the form of various displays which can be called up on either color CRT. A video hardcopy device is connected to the console which will make monochrome paper copies of whatever is on any of the CRT screens.

The CRT's, graphics controller and hardcopy device are commercial equipment; NBSTF used Mitsubishi CRT's, Grinnel graphics controllers, and a Versatek video hardcopy unit. The touch panel/knob panel is an LBL-developed, microprocessor based unit used in a number of control

systems (NBSTF, Doublet-III, and the Bay Area Rapid Transit system [BART]).

4.6 ZEPHYR Controls

This section of the report describes the communication between the NBCS and ZCCS. The system is essentially the same as that currently in use at Doublet-III for communication between the four-beamline, eight-source NBIS and the Doublet-III Tokamak Control computer. The substantial investment in high level NB control software allows ZCCS to treat the entire beamline as a simple "black box." ZCCS simply specifies the operating voltage and on-times for each NBIS via analog voltages, e.g., 0 V for 0 kV, 5 V for 40 kV, etc.

The NB system frequently uses analog signals for communication, even in some instances between basically digital devices (like two computers). This is because it is universal (any process control computer can generate and receive 0 - 10V signals), it is easy to troubleshoot (the signal can be tested by a scope or meter and generated by any signal generator) and because large-scale integrated circuits have made system costs almost solely a function of the number of interconnections (10 bits of information can go over a single wire in analog form but require ten wires in digital form).

In addition, the ZEPHYR timing system must supply a pulse to the NB timing system about two minutes before a shot to allow it to set up (items like power supply tap changes can take more than a minute to complete), and a pulse three seconds before a shot to initiate the NB firing sequence (the NB will fire at some fixed time - accurate to microseconds - from this last pulse).

Owing to the unfinished state of the ZEPHYR ICD, the nature of communication from the NB computer to ZCCS is not well defined. Initially, we envision communication of a minimal amount of information, including such items as state of beam line readiness, acknowledgment of "FIRE" command, etc., which could be supplied via a single sixteen-bit register. Eventually, the NB computer will likely be required to transmit a considerably larger amount of information on the NBIS performance data following each shot; the exact nature and quantity this information is likely to evolve with operating experience. To permit transmission of such additional information, the NBCS includes an intercomputer serial network (software and hardware) conforming to international CCITT Standard X.25. It would then merely be necessary for ZEPHYR to supply the receiving network link (primarily software) and specify the additional information desired.

When the NB computer receives the "setup" timing pulse, it reads the desired operating voltage and beam pulse length, computes accel, arc, gradient grid, suppressor, and filament power supply settings using the optimum operating point predicted by the source models for that voltage, commands the power supplies to those settings, and sets up the control timing and data acquisition sequence appropriate for a shot into ZEPHYR. Local operation of the beamline is accomplished via touchpanel buttons which select among various operating modes (start-up, conditioning, beam to calorimeter, etc.) and cause the ZCCS pulse to be ignored.

4.7 Software Architecture

The NB system consists of a number of small "tasks." Each task

involves performing a single specific function (e.g., read thermocouple past-shot temperatures, fit a bi-gaussian to a temperature distribution, display current shot on a graph of the source models, etc.). All data input to a task come from an external data base (a task has no memory - it keeps no internal data). Each task produces a single output which is put into the data base (i.e., a set of temperatures, the fit parameters). No task is allowed to do something like read temperatures and display them; a display would be a second output.

The system is constrained this way to reduce its complexity.¹¹ The basic operation of any program is to use some data to produce other data. Since programs have only a single output, there are no side effects; e.g., one doesn't worry about the operation of updating the source models resulting in the display currently on the right hand screen being wiped out. The output completely characterizes the program; e.g., for someone writing a tuning program to use the results of the fitting program, it is only necessary to understand what the fit output parameters are, not how they were generated.

Since tasks have no memory, failures are easy to test and isolate; i.e., since there are no internal data, the output is solely a function of the inputs, and so an incorrect output is due to either an incorrect input or a mistake in the algorithm. The former is easy to test since the inputs are always available for inspection in the data base. The latter is easy to correct since the same input must always generate the same output.

In general, it is reasonable to run the same algorithm (task) on any subset of a type of data (e.g., displaying the temperatures on an

aperture is the same algorithm, regardless of which aperture). Thus, a task is started by handing it the names of the data base items it is to use as inputs and outputs. When a task has processed the list of data, it sends whoever started it a message saying it is done processing the set of data. Since a task produces a single output, this completion message is equivalent to stating that the task's output data are now available.

A special task called the Dispatcher manages all of the task sequencing. It works from a description of the inputs and outputs of each task and the following rules:

- a task is started if it is "requested" (initial requests are generated by an input such as an interrupt from the timing system or a signal from touch panel) and all of its inputs are available.
- a task is requested if its output is needed by any other requested task.

The first rule causes a task not to be run until everything necessary for it to run is available. For example, the operator may request the fit to be displayed at any time during a shot; however, no display will appear until the fit parameters for the current shot have been computed.

The second of the above rules causes requests to percolate "backwards" from the requested output, and creates a system which automatically does only what is necessary: The only programs run are those which are necessary precursors of some display or program requested by the operator or necessary for the safe operation of the NBIS (these latter programs are automatically requested). For example,

requesting a display of the plasma probe profile results in a request for filtering and averaging of the plasma probe waveforms. The request for averaging will in turn generate a request for acquisition of the plasma probe waveforms. The profile display task knows nothing of either of these requests - it will simply run when the data have been acquired and averaged. If it is requested again before the next shot, it will run immediately (since all of its data are available) and there are no extraneous requests for the averaging or acquisition. If the display is not requested, the probe data will be neither acquired nor averaged, unless of course some other request requires such data.

The NBSTF/Doublet-III NB software system consists of about 60 small tasks which, via various sets of input data, produce about 200 displays and perform about 100 additional control or housekeeping functions. The average task size is about 200 lines (three pages of code). The per-shot data base consists of about 15K 16-bit words. This data base is for a single-source beamline; for a ZEPHYR beamline, it would be three times this. The number of tasks, of course, depends only on the number of types of data, not on the quantity of data, and is unchanged for ZEPHYR.

References

1. Elischer, V., Jacobson, V., Wiley, K., "The Cost of Program Development for Small Computers in a Large Accelerator Control System," LBL-4238, 1975.
2. Elischer, V., Fehr, S., Jacobson, V., Wiley, K., "Designing the TFTR Neutral Beam Line Control System Software to Aid the Engineer," LBL-4315, November, 1975.
3. Elischer, V., Fiddler, J., "Graphical human Interface to a Neutral Beam System," SIGGRAPH 1979 Sixth Annual Conference on Computer Graphics and Interactive Techniques, Chicago, IL, August, 1979.
4. Kohli, J., Moore, C.D., Drobnis, D.D., Elischer, V., Kilgore, R., Uber, D., "Instrumentation and Control of the Doublet-III Neutral Beam Injector System, Eighth Symposium on Engineering Problems of Fusion Research," San Francisco, CA, November 1979.
5. TFTR Neutral Beam Injection System Conceptual Design, LBL/LLL CTR Staff, LBL-3296, August 1975.
6. Lietzke, A.F., Berkner, K.H., Feist, J.H., Smith, R.R., Baker, W.R., Hopkins, D.B., Lutz, I.C., Bereznai, D., Jacobson, V., "Initial Operation of NBSTF, the Prototype Neutral Beamline for TFTR," Twenty-second Annual Meeting of the APS Division of Plasma Physics, San Diego, CA, November 10, 1980.
7. Theil, E., Elischer, V., Fiddler, J., Jacobs, N.J.D.J., Jacobson, V., Lawhorn, R., Uber, D., Wilner, D., "Progress in Computer-Assisted Diagnosis and Control of Neutral Beam Lines," Eleventh Symposium on Fusion Technology, Oxford, England, September 1980.
8. Belshé, R.A., Elischer, V., Jacobson, V., "The Feasibility and Advantages of Commercial Process I/O Systems for Accelerator Control," IEEE Particle Accelerator Conference, Washington, D.C., March 1975.
9. Boehm, B. W., "Software and Its Impact: A Quantitative Assessment," Datamation, Vol. 19, No. 5, May 1973, p. 52.
10. Brooks, F.P., "The Mythical Man Month," Datamation, Vol. 20, No. 12, December 1974, p. 45.
11. Endres, A.B., "An Analysis of Errors and Their Causes in System Programs," IEEE Transactions on Software Engineering, Vol. SE-1, No. 2, June 1975.
12. Rouse, W.B., "Human Problem Solving Performance in a Fault Diagnosis Task," IEEE Transactions on Systems, Man and Cybernetics, Vol. SMC-8, No. 4, April 1978, p. 258.

APPENDIX A: THE ZEPHYR INTERFACE CONTROL DOCUMENT

The ZEPHYR Interface Control Document (ICD) is the result of a joint effort by IPP, LBL, and ORNL. The present draft version resulted from a meeting of members of the three laboratories held in Oak Ridge in December of 1980, just prior to the termination of the project by the German government.

While the specifications given in the ICD represent a consensus of the participants at that meeting, there was no formal agreement made, in part because some of the major areas were still undefined.

Three of the figures appearing in the ICD (Figs. 3.6.1.1-3.6.1.3), showing gamma-ray activity as a function of neutron activation, were reproduced from copyrighted material, and have been eliminated from the version appearing in the present report. The remaining figures in the ICD have been reproduced here with the permission of the Max-Planck-Institut für Plasmaphysik.

ZEPHYR Interface Control Document

Contents

1. Introduction
2. General (tolerances, standards)
3. Detailed Interface Specifications
 - 3.1 Beam Plasma Interface
 - 3.1.1 Plasma target ($R_C(h)$, $R_C(v)$, $X_{CFF}(v)$)
 - 3.1.2 Main beam parameters (power, neutral fraction, voltage, gas, pulse length)
 - 3.1.3 Other requirements (duty cycle, maintenance, number of lines, availability, reliability, impurities)
 - 3.1.4 Lifetime
 - 3.1.5 Time variations (on/off, ripple, slow variation)
 - 3.1.6 Flow of gas from torus
 - 3.2 NBIS Duct Assembly
 - 3.2.1 Flange/porthole geometry
 - 3.2.2 Duct outlines
 - 3.2.3 Scrapers
 - 3.2.4 Source steering
 - 3.2.5 Beam positioning (measurements required for 3.2.4)
 - 3.3 Space and Buildings
 - 3.3.1 Open air space for power supply
 - 3.3.2 Space in NBIS building for auxilliary power supply and modulators
 - 3.3.3 Space available in basement of experimental hall

- 3.3.4 Box support system (vertical and longitudinal movement)
- 3.3.5 Floor loading
- 3.3.6 Crane
- 3.3.7 Floor penetrations
- 3.3.8 Access to basement
- 3.3.9 Clear height in basement

- 3.4 Power Supply
 - 3.4.1 Definition of electrical power interface point
 - 3.4.2 Input power requirements
 - 3.4.3 Permissible power load from mains
 - 3.4.4 Characteristics and "load" limits of motor-generator system
 - 3.4.5 Tests
 - 3.4.6 Monitoring and control; maintenance and repair

- 3.5 NBIS Services
 - 3.5.1 Water cooling
 - 3.5.2 LN₂
 - 3.5.3 LHe
 - 3.5.4 External vacuum
 - 3.5.5 Compressed air
 - 3.5.6 Electronegative gases
 - 3.5.7 D₂ gas
 - 3.5.8 Hot inert gas (tritium purging)
 - 3.5.9-11 Connections

3.6 Environment

3.6.1 Building temperature limits

3.6.2 Building humidity limits

3.6.3 Magnetic fields

3.6.4 Radiation

3.6.5 Tritium

3.6.6 Air circulation

3.7 Safety

3.7.1 H₂/D₂ in air

3.7.2 Tritium inventory in beam lines and monitoring

3.7.3 Tritium handling

3.7.4 General safety systems (interlocks, "safety valves")

3.7.5 Safety information to general control

3.7.6 Seismic requirements

3.8 Remote Handling

3.8.1-7 General considerations

3.8.8 Circular flange details

3.8.9 Rectangular flange details

3.8.10 Recessing of vacuum-sealing surface

3.9 Control System and Diagnostics

3.9.1 Philosophy and conceptual design of control system

3.9.2 Diagnostics (vacuum, residual gas analysis, beam power "distribution," general operation)

4.0 Amending Procedure for ICD

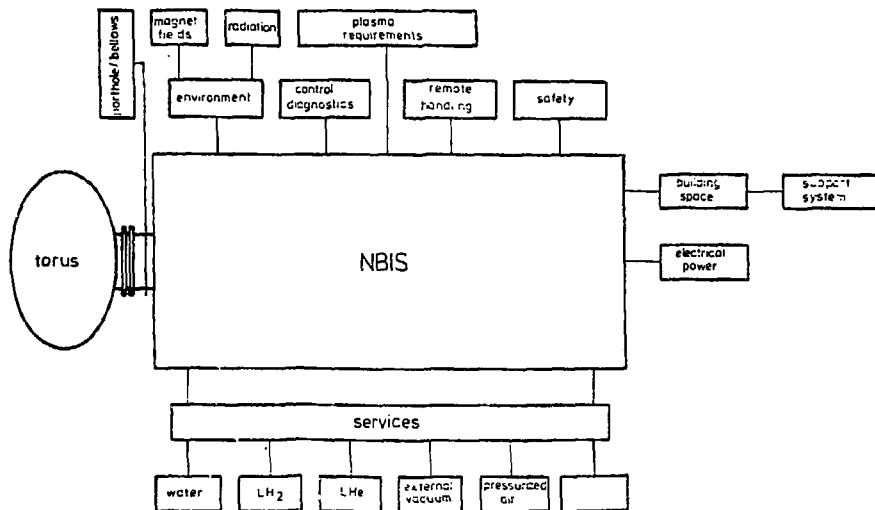

Fig. 1

2.) General Requirements

- 2.1 The metric system shall be used. Dimensions on drawings shall be specified in millimeters.
- 2.2 In single cases it might be necessary to use German standards (voltage test etc.). These cases are tbd.
- 2.3 Component parts, such as screws, nuts, bolts, connections, etc., shall, whenever possible, be metric standard.

3.1 Beam/plasma interface

3.1.1 Plasma Target

tangential radii of beam centers	$28 \text{ cm} \leq R_c \leq 86 \text{ cm}$
tangential radius for vertical source array	$50 < R_c < 60 \text{ cm}$
vertical limits at plasma center	$-21 \text{ cm} \leq x \leq 21 \text{ cm}$

3.1.2 main parameters of neutral beam

total neutral power to the plasma target	= 25 MW
neutral power fraction with full energy	$\geq 60 \%$
acceleration voltage	$\geq 160 \text{ kV}$
kind of gas	deuterium
nominal pulse length	1.5 s

3.1.3 other requirements

duty cycle	$\geq 1.25 \%$
maintenance interval for components that require remote handling (following source conditioning)	10^3 shots into plasma
maintenance and repair of individual beam lines and associated systems shall not interfere with operation of other beam lines.	
number of beam lines	≤ 6
a number of less than 6 beam lines is desirable.	
overall reliability or percentage of successful shots with at least 25 MW to target	$> 75 \%$
It must be possible to operate single beam lines and single sources individually and independent of each other (e.g. in time, voltage etc.)	
availability	$> 80 \%$
impurity content as low as possible by the selection of appropriate materials	
hydrogen	$< \text{tbd}$

3.1.4 life time

The design goal for the life time of all components other than filaments shall be	$> 2 \cdot 10^5$ beam pulses
---	------------------------------

life time of filaments

tbd

3.1.5 variations in time

turn-on, turn-off. Voltage of the neutral beam shall reach 90 % of the design values in 10 ms and 97 % (design goal) of the design values in 250 ms. Single sources shall be operable individually in time and voltage.

In case of sequential turn-on of the sources the minimum time difference Δt between the turn-on of consecutive sources shall be ≤ 15 ms.

For normal turn-off the same requirements as for turn-on are valid.

In case of an emergency because e.g. a fault in the beam line or in any other system, it shall be possible to turn off any or all beams in times $t < 100 \mu s$.

Ripple. The peak to peak ripple in voltage shall not be larger than 4 % (design goal). On the average over the pulse length the design values shall be obtained.

Slow variations in time. A slow increase in voltage and/or power up to 2 % (design goal) of the design value is tolerable, as long as on the average over the pulse length the design values are obtained.

It shall be possible to choose the operating voltage in steps of 10 kV or less between 40 and 160 kV.

3.1.6 Gas flow from the torus into the beam line

is

tbd

3.2 NBIS/duct assembly

- 3.2.1 The technical interface is given by a flange, that connects the beam line box and the duct assembly. The size and position of this flange is given in the drawing SK 943. More details of the flange are tbd.
The geometry of the porthole is given in drawing 1A CVN 0002.
- 3.2.2 At present the outline of the duct is as shown on the drawing SK 943. The IPP shall investigate, whether the diameter of the duct can be enlarged to accept the vertical arrangement of 4 ORNL-sources or the horizontal arrangement of 4 LBL-sources. The US-Labs shall investigate the possibilities to include the fast shutter in the beam line box, as the duct length thereby could be reduced by ~ 70 cm.
- 3.2.3 The dashed line in drawing SK 943 determines the scraper area. In this area the design goal for the power density in beam direction shall be less than 0.3 kW/cm^2 on the average in time over the pulse length.
- 3.2.4 A steering mechanism for the sources has to be installed, that allows positioning of the beams in the port to an accuracy of ± 1 cm.
- 3.2.5 In close cooperation a measuring technique is to be developed which allows correct positioning of the beam in the duct to ± 1 cm.

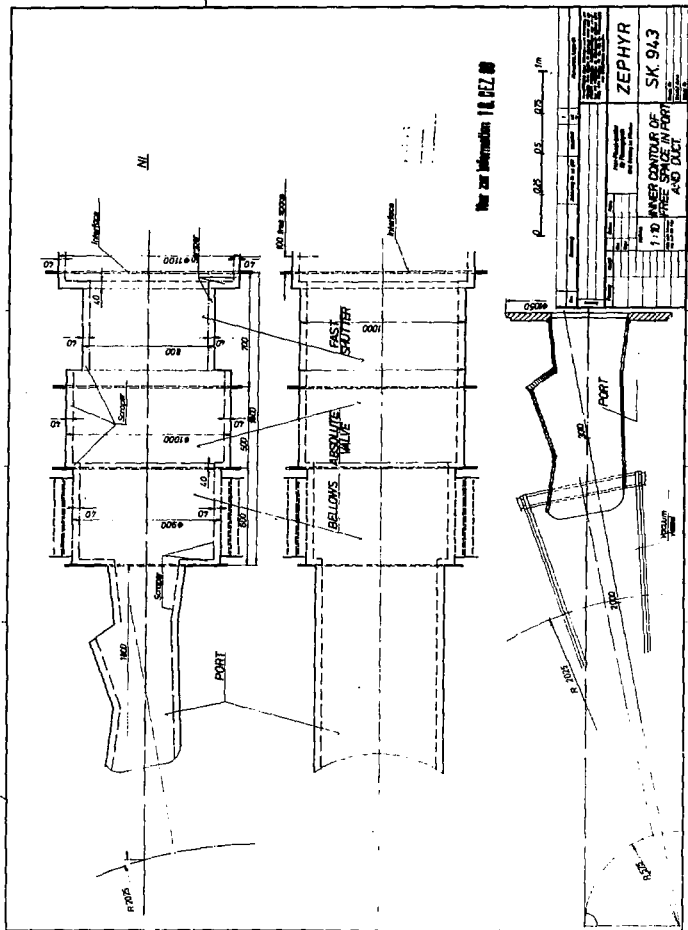

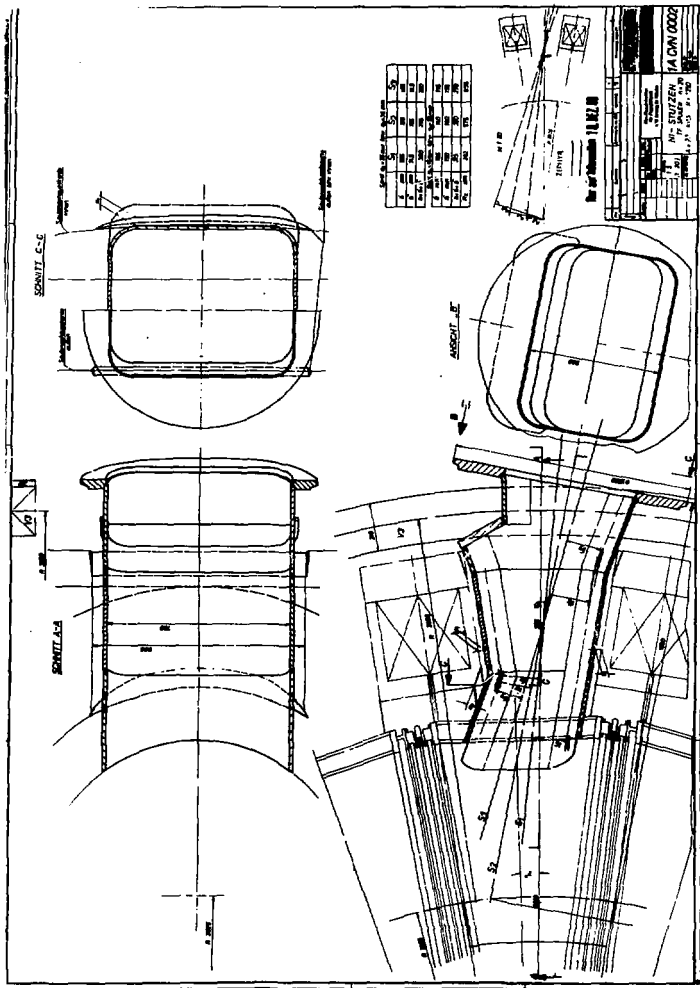

3.3 NBIS/space and buildings

Fig. 3.3.1 gives a top view of the buildings and the available open air space

Fig. 3.3.2 gives a top view of the building at the experimental level

Fig. 3.3.3 gives a top view of the building at the basement level

Fig. 3.3.4 gives two cross-sections through the experimental building

Fig. 3.3.5 gives a cross-section through the experiment

the cross-sectional area that is available for the beam line boxes is given in drawing OA CVA 0009. The midplane of the torus is 3.5 m above the floor. The available height in the experimental hall including the space for mounting is about 15 m as can be seen from Fig. 3.3.4.

- 3.3.1 2400 m² open air space is available for power supplies.
- 3.3.2 The neutral injection building and parts of its basement are available for auxiliary power supplies and modulators (see Figs. 3.3.2, 3.3.3 and 3.3.4).
- 3.3.3 In the basement of the experimental hall the space below the beam line tbd is available for neutral injection.
- 3.3.4 Box support system. Motion of the box for about 0.2 m in the direction of the beam shall be possible. The box shall move on rails. The rails are installed by IPP. Width and profile of the rail are tbd. The support system shall include provisions to adjust the box to the torus also in vertical direction.
- 3.3.5 The permissible loading of the floor in the experimental hall is about 10 to/m². The floor loading in other areas is tbd.
- 3.3.6 The lifting power of the crane in the experimental hall is 100 to. The hook height of the crane is 15 m.
- 3.3.7 Size, number and nature of floor penetrations for NBIS are tbd.
- 3.3.8 Size of side doors and floor openings to basement area are tbd.
- 3.3.9 Clear height of basement area is tbd.

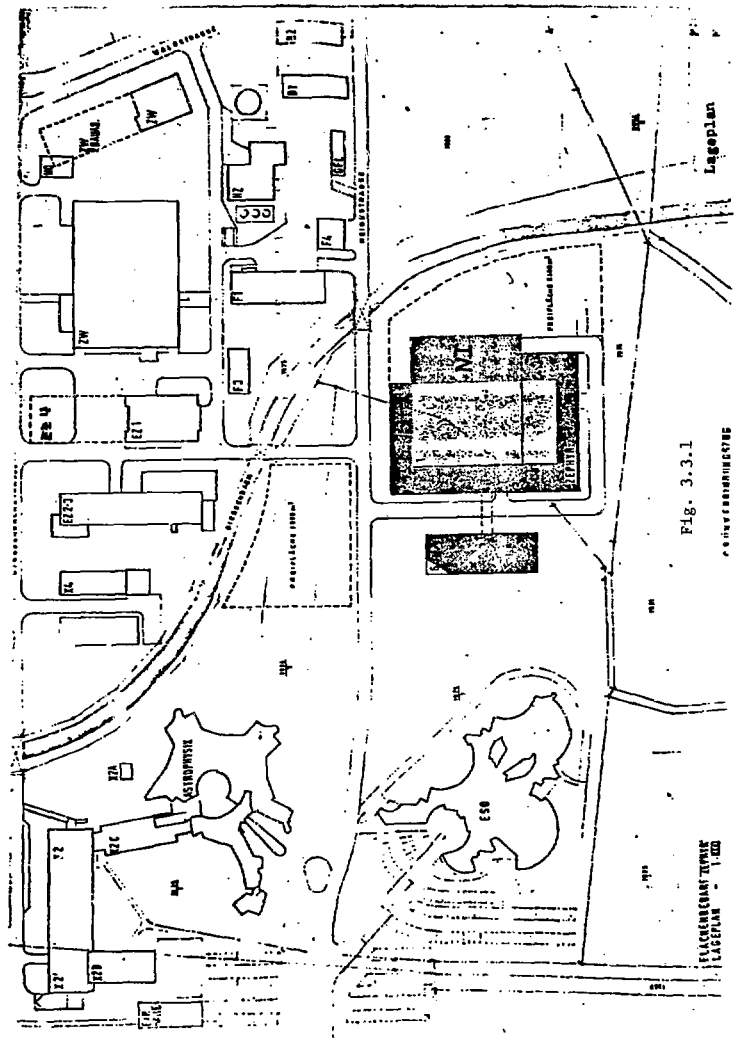

Fig. 3.3.1

PLAN OF BLACKBURN TOWER

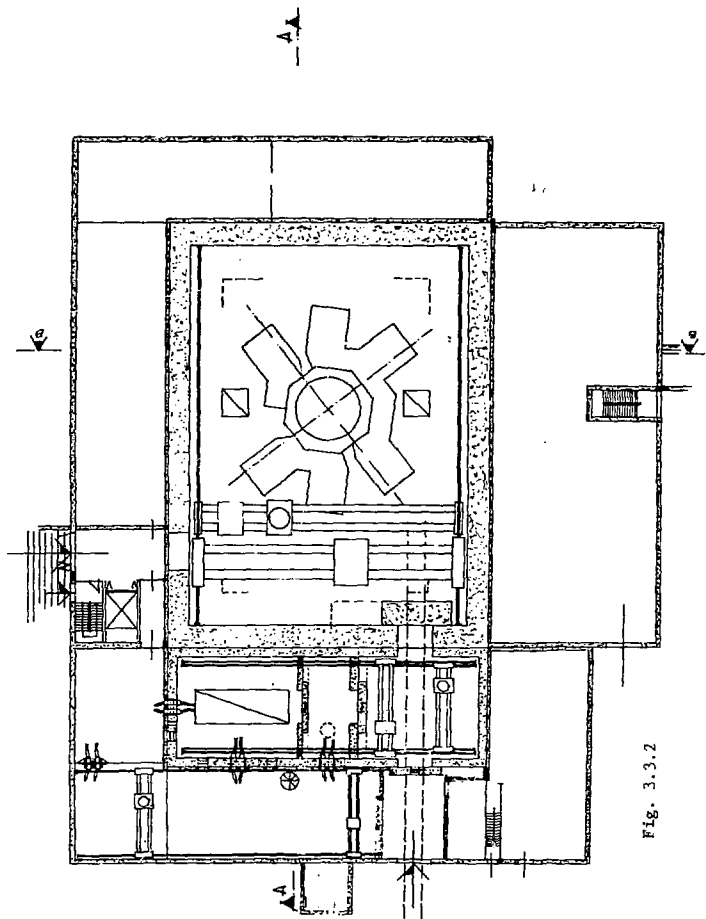

Fig. 3.3.2

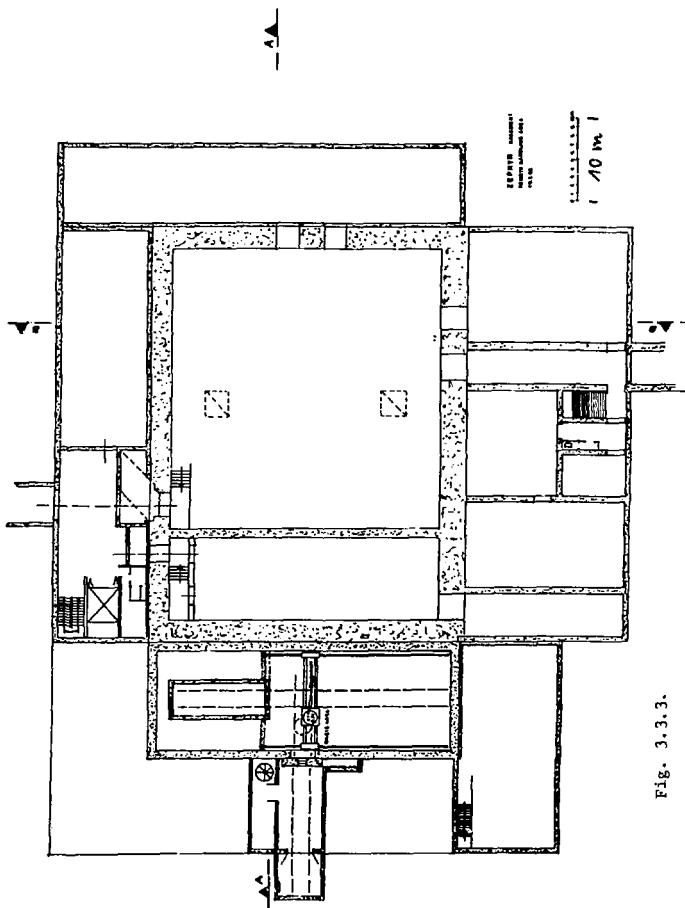

Fig. 3.3.3.

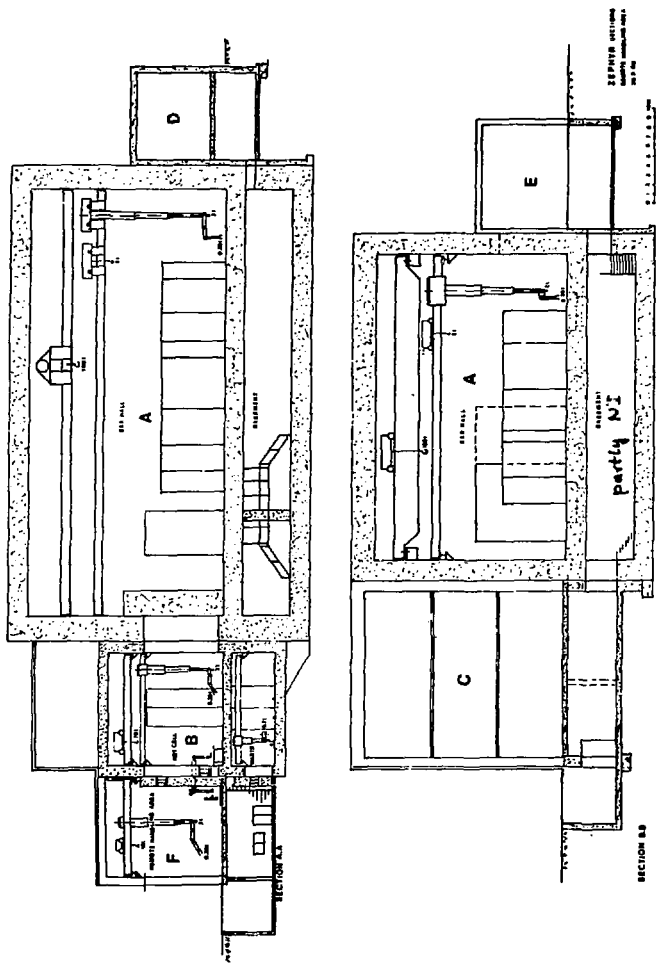

Fig. 3.3.4

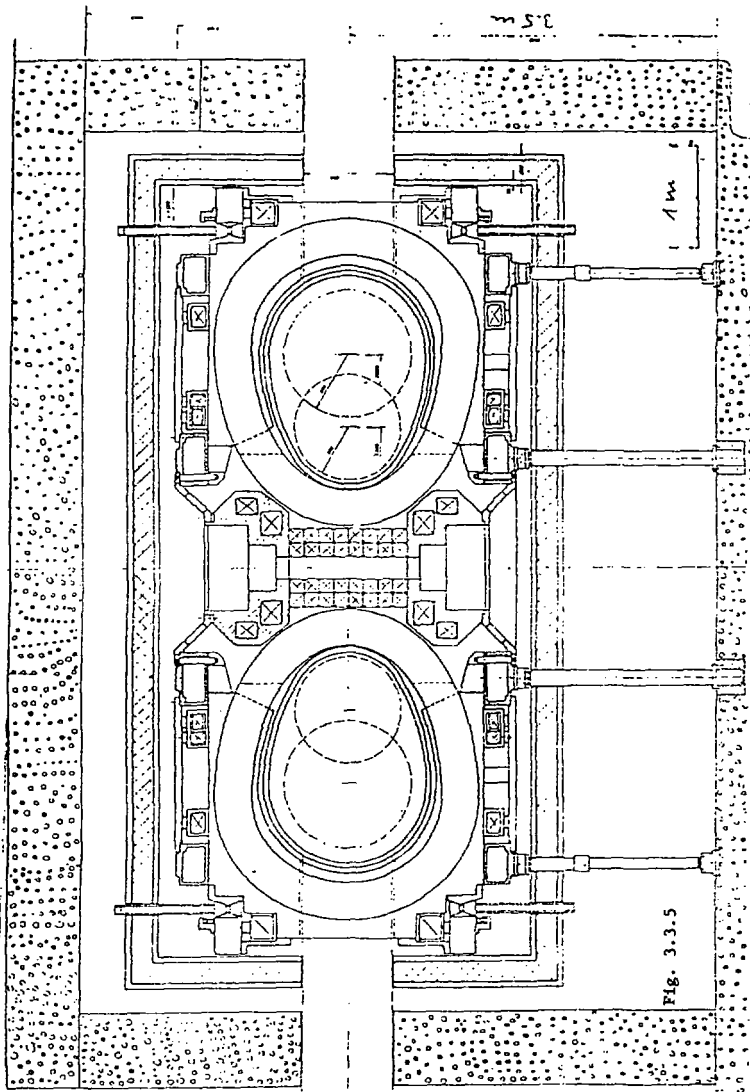
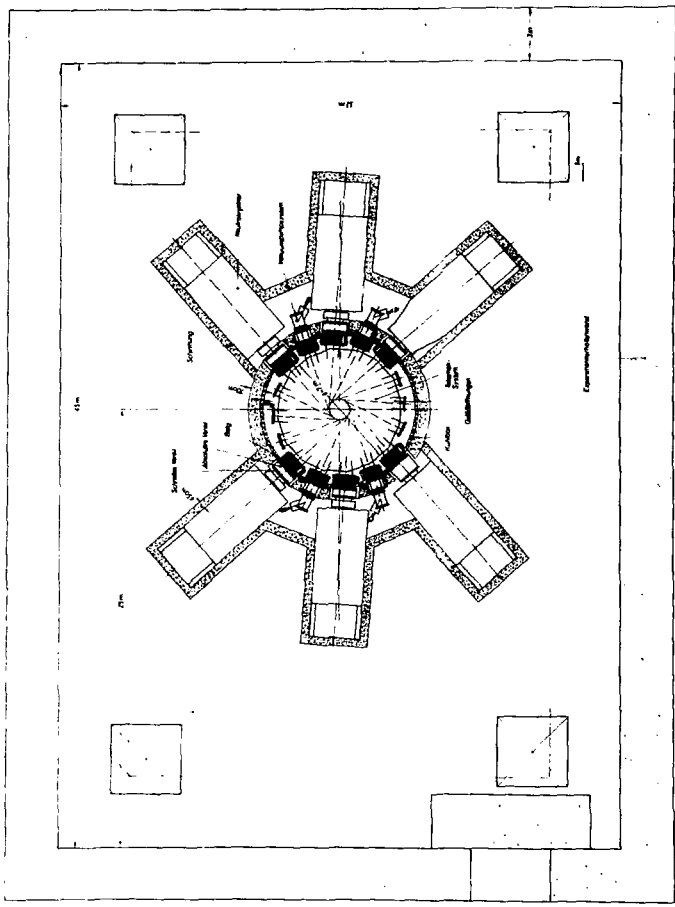

FIG. 3.3-5

217
217
217
217



3.4 Power Supply

3.4.1 Responsibilities

IPP provides the electric power for the NI system in a 3-phase AC mode (10 kV) as specified in the following at interface locations which are still to be determined.

The U.S. lab is responsible for the power supply facilities from the 10 kV interface mentioned above to switch board at the NI boxes and other terminals.

3.4.2 Basic Requirements

The basic power supply requirements of the ZEPHYR neutral injection system are listed in Fig. 3.4.1a to 3.4.1d.

The numbers contained there are as required by LBL and ORNL. IPP cannot provide a 50 Hz pulse power from the mains above 5 MVA. Possible solutions to overcome the problem:

- power factor improvement
- stagger firing for conditioning pulses
- motor generator supply.

3.4.3 Systems supplied from the Mains

The energy will be transferred to the NI power supply interface by 10 kV cables.

Switch system plan: see Fig. 3.4.2.1

Maximum tolerable voltage drop on 110 kV

side due to pulse loading: 0.5 % (1 % once a day).

Maximum tolerable voltage drop on 10 kV

side: 3 % (5 % once a day)

Voltage harmonics allowed at 10 kV side of 32 MVA transformer

odd number harmonics	allowed percentage of first harmonic
3	0.85 %
5	0.65 %
7	0.60 %
9 and 11	0.40 %
13	0.30 %
15 to 39	0.25 %
even number harmonics	
2 to 40	0.2 %
Asymmetry in power load allowed	TBD

3.4.4 Systems Supplied from a Fly Wheel Generator

3.4.4.1 Users

See Fig. 3.4.1a to 3.4.1b (at least 78 - 110 Hz users).

3.4.4.2 Power Transfer

The power transfer from the fly wheel generator to the NI interfaces will be performed by 10 kV cables.

3.4.4.3 Generator Data

The generator is not yet specified, so the following numbers are still matter of discussion except those which are marked with an f. The f-marked numbers are maximum values and can be taken as a basis for further planning of NBPS.

Power	500 MVA
Stored energy	5.2 GJ
Energy available	2.6 GJ
Output voltage	10 kV (f)
Frequency	78 - 110 Hz (f)

Frequency change during 1.5 s pulse of 240 MVA (worst case, including 260 MW for additional user) 10 Hz (f)

Long-term output voltage constancy $\pm 2\%$ (f)

LBL requirement $\pm 1\%$

Maximum output voltage drop for 240 MVA pulse loading 10% (f)

Maximum overvoltage in case of 240 MVA load shedding 10% (< 1 kV)

Output voltage recovery time to $\pm 2\%$ for 240 MVA pulse loading ≤ 250 ms (f)

($\pm 1\%$ for LBL)

- Output voltage waveform aberration no even number harmonics
no third harmonic
for all other harmonics

$$U_h = 100 \frac{\sqrt{\sum U_{hi}^2}}{U} \leq 2,5\%$$

$i : 5, 7, 9$

U_h = effective voltage of all harmonics

U_{hi} = effective voltage of individual harmonic

U = generator voltage

NB load harmonics magnitudes typical for 12 pulse rectifier loads and 15% peak-peak line currents allowed: phase controlled voltage variations.

Protection systems of generator

Internal protection systems causes de-excitation of the generator (voltage to zero in < 400 ms)

External protection system (IS-limiter): In case of a short in the outer circuit, explosion breakers open in 1 ms

Maximum short circuit current 300 kA

3.4.5 Tests

Test programs for the main neutral beam components have to be specified in mutual agreement and in parallel to progress of work.

3.4.6 Monitoring and Control/Maintenance and Repair

See general part of Interface Document.

User	Voltage	Power MW	Power factor	Frequency Hz	Pulse length	Repet. rate	Number of shots
A: Pumps, diagnostics, control and monitoring	220/380 V AC/3 phase	0.5	0.8	50	steady state		--
B: Heating of switch tubes	10 kV AC/3 phase	0.2	0.9	50	steady state		--
C: Magnets, filament heating	10 kV AC/3 phase	0.15	0.75	50	steady state		--
D: Plasma sources Arc	10 kV AC/3 phase	3.6	0.75	50	2s	2 min	10^6
E: Accel. System Decel. System	10 kV AC/3 phase	150 5	0.90 0.9	78 - 110 78 - 110	1.5s 1.5s	2 min 2 min	10^6 10^6

Power supply for services like cooling etc. is not included.

Fig. 3.4.1a: IPP-ZEPHYR Power Supply for Neutral Injection/Interface Data as required by ORNL, based on 12 sources.

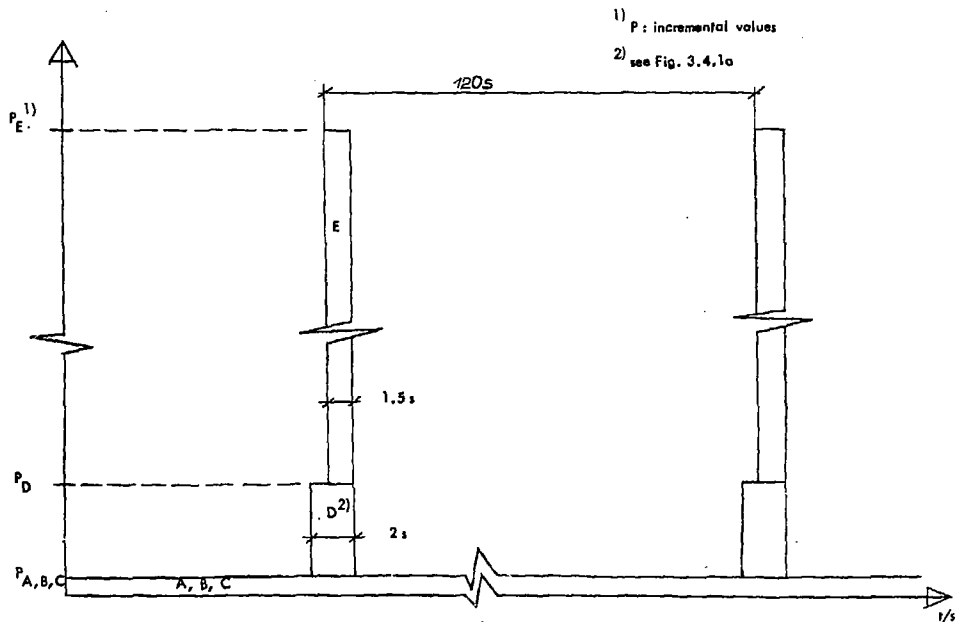

Fig. 3.4.1b: IPP-ZEPHYR power supply for neutral injection/Interface power versus time as required by ORNL, based on 12 sources

User	Voltage	Power MW	Power factor	Frequency Hz	Pulse length	Repet. rate	Number of shots
A: Pumps, diagnostics, control and monitoring	220/380 V AC/3 phase	0.5	0.8	50	steady state		--
B: Heating switch tubes	10 kV AC/3 phase .. (0 if no tube)	0.24	0.9	50	steady state		--
C: Magnets, filament heating	10 kV AC/3 phase	2.5	0.7	50	3.5 s	2 min	10 ⁶
D: Plasma sources Arc	10 kV AC/3 phase	2.5	0.4	50	2s	2 min	10 ⁶
E: Accel. System	10 kV	250	0.9	78 - 110	1.5 s	2 min	10 ⁶
Decel. System	AC/3 phase	3	0.9	78 - 110	1.5 s	2 min	10 ⁶

Power supply for services like cooling etc. is not included.

Fig. 3.4.1c: IPP-ZEPHYR Power Supply for Neutral Injection/Interface data as required by LBL, based on 24 sources.

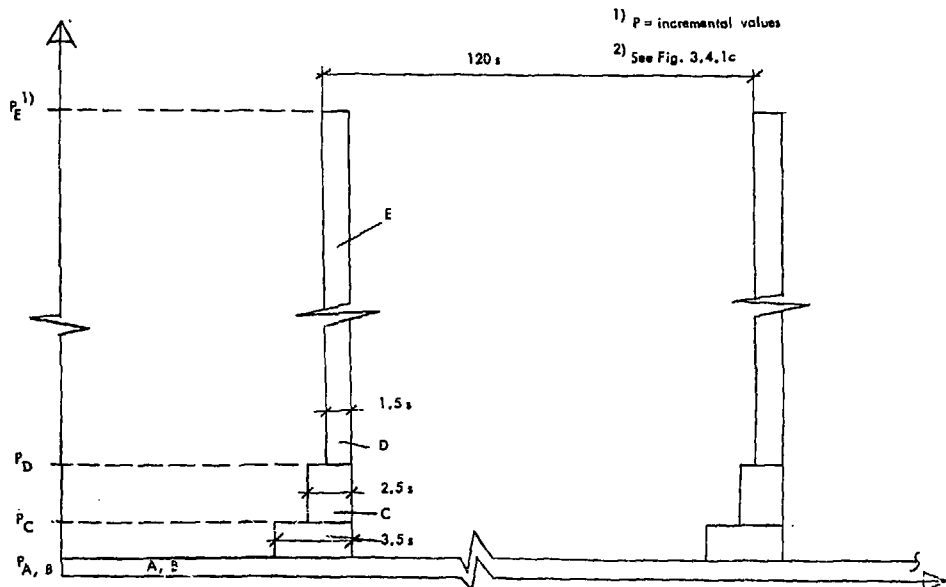

Fig. 3.4.1d: IPP-ZEPHYR power supply for neutral injection/interface power versus time as required by LBL, based on 24 sources.

Power line; 110 kV; 50 Hz, 3 phase

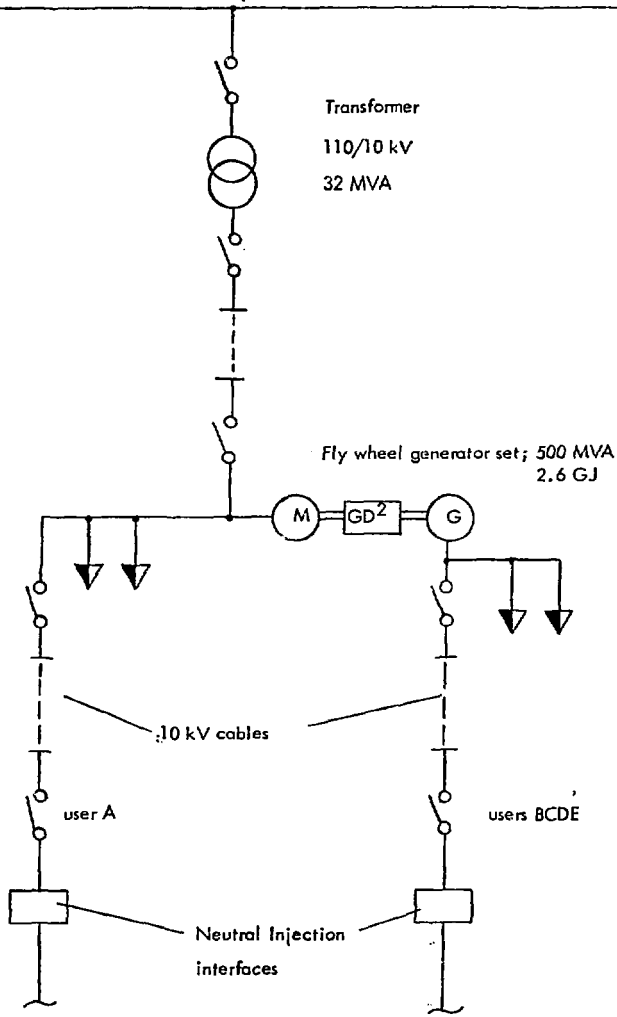

Fig. 3.4.2.1: IPP ZEPHYR NI power supply/instative schema
A-30

3.5 NBIS / services

3.5.1 water cooling, details tbd

3.5.2 LN_2 , details tbd

3.5.3 LHe , details tbd

The interface for the cryosystem and ZEPHYR is defined in Fig. 3.5.1.2

3.5.4 external vacuum. At the source side of the beam line box a port with 400 mm \varnothing shall be available for pumping. This port shall be accessible for remote handling from above.

3.5.5 pressurized air, details tbd

3.5.6 electronegative gases, details tbd

3.5.7 deuterium gas, details tbd

3.5.8 hot inert gas (up to 150 °C) for wall cleaning. Details tbd

The beam line box shall have two ports far apart with 100 mm \varnothing for the circulation of hot gases. The interface are the remotely handle flanges. Gas supply and tritium handling falls in to the responsibility of IPP.

3.5.9 The number o connections to the beam line box shall be as small as possible. See 3.8.

3.5.10 All connections shall be done by remote handling, preferably using quick disconnects. See 3.8.

3.5.11 The interface for each service line is a connection at a local distribution point on each beam line.

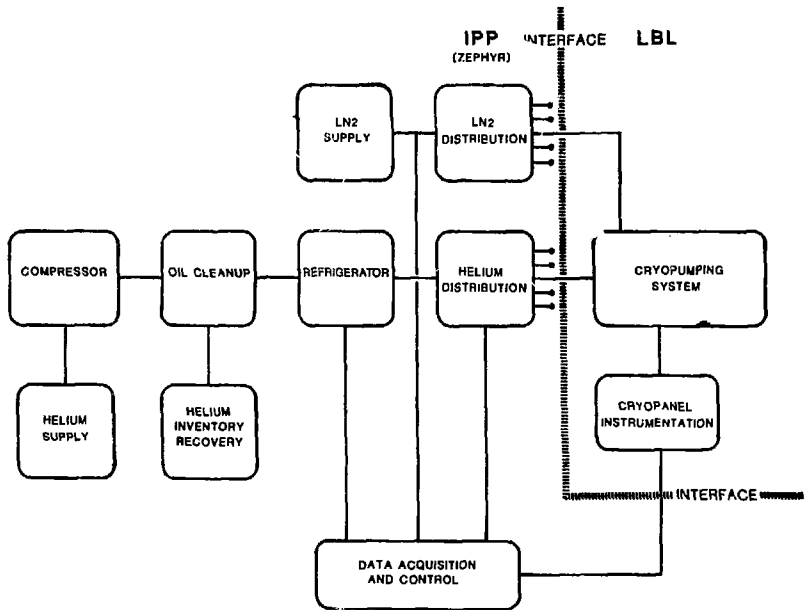

Fig. 3.5.1.2

CRYOSYSTEM INTERFACE

3.6 NBIS / environment

3.6.1 The IPP will provide temperatures as listed below

- | | | |
|----|-------------------------------------|-------------------------------|
| a) | NI-building | $15^{\circ} < T < 25^{\circ}$ |
| b) | Experimental hall | $15^{\circ} < T < 35^{\circ}$ |
| c) | Basement | $15^{\circ} < T < 25^{\circ}$ |
| d) | Room for control
and diagnostics | 20 - 22 $^{\circ}$ |

3.6.2 The IPP will provide an air humidity as listed below

- | | | |
|----|--|------------------|
| a) | NI-building | 30 % < RH < 80 % |
| b) | Experimental hall | 30 % < RH < 80 % |
| c) | Basement | 30 % < RH < 80 % |
| d) | Room for control
and diagnostics, tbd | |

3.6.3 Magnetic fields

The magnetic field outside the torus is mainly determined by the vertical field coils. The field is given in Fig. 3.6.3.

The time dependence of the vertical coil current is given in Fig. 3.6.3.2.

No active or passive component of the beam line shall give a contribution to the horizontal component of the field, that averaged over the whole plasma volume exceeds 0.8 mT (for full vertical field).

3.6.4 Radiation

The beam line is exposed to the flux of neutrons. This flux is $3 \cdot 10^{14} \text{ cm}^{-2} \text{ s}^{-1}$ in the porthole, of which $5 \cdot 10^{13} \text{ cm}^{-2} \text{ s}^{-1}$ is at an energy of 14 MeV.

The neutron flux into the beam line shall be reduced as much as possible. It could be advisable to fill a suitable space behind the end scrapers in the box with a hydrogen rich material (paraffin).

Isolation materials used in the beam line shall be able to withstand a neutron and γ - radiation of 10^9 rad.

If a choice of materials is possible, materials shall be preferred that have a lower level of γ - radiation a few days after the interruption of the experiment. Fig. 3.6.4.4 to 3 give the γ - radiation of selected materials as a function of time for three energy ranges of the neutrons.

Elements that can be used without restrictions are: H, C, N, O, F, Be, Ar, K, Ca, Bi, Li, Ge, Br.

The material of the beam line box is tbd.

3.6.5 Tritium

To minimize the amount of tritium in the beam line a fast shutter with slow opening, but fast closing (≤ 0.3 s) time is necessary. Its conductance for deuterium (in closed position) shall be less than 50 l/s. As the duct assembly shall be as short as possible, it shall be considered whether a fast shutter can be installed in the beam line box.

The presence of tritium requires the use of double seals, of which the inner one shall be metallic, the outer one e.g. an elastomer (e.g. viton ER 60).

The seals in the source are tbd.

To allow the use of metallic seals in the whole system all flanges shall be from stainless steel.

3.6.6 Air circulation in the neutral injection building and basement of the experimental hall is tbd.

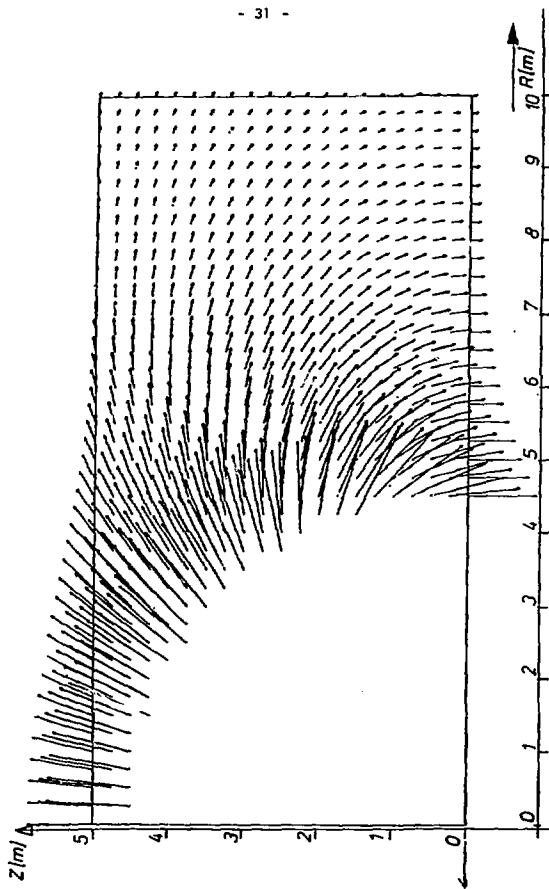

Fig. 3.6.3

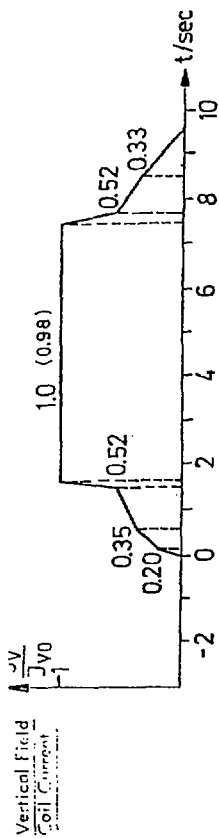

Fig. 3.6.3.2

- 3.7 NBIS / safety
- 3.7.1 The corresponding STP volume of hydrogen (H_2 , D_2) in the beam line shall be less than 4 % of the beam line volume (STP).
- 3.7.2 The maximum tritium inventory allowed in the beam line is TBD. Instrumentation to monitor the tritium inventory in the beam lines will be provided by TBD.
- 3.7.3 The handling of tritium in the exhaust gas from the NBIS is the responsibility of ZEPHYR.
- 3.7.4 The NBIS shall incorporate pressure reliefs, electrical interlocks, key interlocks, and temperature, pressure, flow, vacuum, and radiation monitors and interlocks to a sufficiently redundant degree that equipment and personnel safety are ensured.
- 3.7.5 The NBIS shall report the following safety information to the ZEPHYR central control: tbd
- 3.7.6 Seismic loading requirements are tbd.

- 3.8 NBIS / remote handling**
- 3.8.1** The activation of the material of torus and beam line necessitates remote operation for inspection, maintenance and repair.
- 3.8.2** Repairs of system components need not be made in situ.
- 3.8.3** System components that need inspection or repair shall be removed remotely and be transported to a hot cell. Spare parts shall be available for critical items.
- 3.8.4** If maintenance is unavoidable parts with the longest maintenance interval shall be preferred.
- 3.8.5** Special parts to be remotely operable are: the connecting flanges between duct assembly and beam line box and all flanges for the items that are remotely replaceable.
- 3.8.6** Critical items, that shall be remotely replaceable are:
sources, calorimeters, beam dumps, power recovery systems, diaphragms, scrapers, cryopumps, the magnet, and others tbd. The design goal is that all these items be replaceable independently.
- 3.8.7** To facilitate remote operation the number of connections for services, diagnostics and control shall be minimized. See also 3.5.10.
- 3.8.8** For circular connections special flanges developed by IPP shall be used wherever possible. Dimensions tbd. The free distance of these flanges from the next material plane shall be larger than tbd mm. For details see drawing tbd.
- 3.8.9** Large flanges on top of the box may be connected to the top cover by bolts. Above each screw a cylindrical space with 200 mm \varnothing and height tbd shall be empty for easy access of the manipulator.
- 3.8.10** To protect the sealing surfaces against scratches etc. they shall be recessed.

3.9 NBIS/control and diagnostic

3.9.1 Control

The U.S. laboratory shall be responsible for the control and monitoring system of the NBIS. The interface locations and signals to be exchanged are TBD. It shall be a goal to enhance similarities between the ZEPHYR Central Control System (ZCCS) and the NBIS control to facilitate operation, maintenance, and modifications by ZEPHYR personnel. A preliminary conceptual design of the ZEPHYR control system is shown in Fig. 3.9.1.

3.9.2 Diagnostic

The vacuum in each chamber of the beam line shall be measured. The number of measuring systems shall be redundant (at least 2 gauges per chamber). Each beam line box shall have redundant capabilities for residual gas analyzer measurements.

Other diagnostics for the operation, conditioning, fault detection etc. shall be provided by the designing team in its responsibility.

It shall be possible to measure the beam power to the different components of the beam line.

4. Amendments to ICD

Changes to this document may be proposed by IPP, ORNL, or LBL.

The proposed changes are to be communicated promptly and in writing, by the party proposing them, to all interested parties, including DOE and MIT. The proposed changes will become effective by mutual agreement between IPP and the U.S. laboratory proposing the change, providing the change does not adversely effect the other U.S. Laboratory.

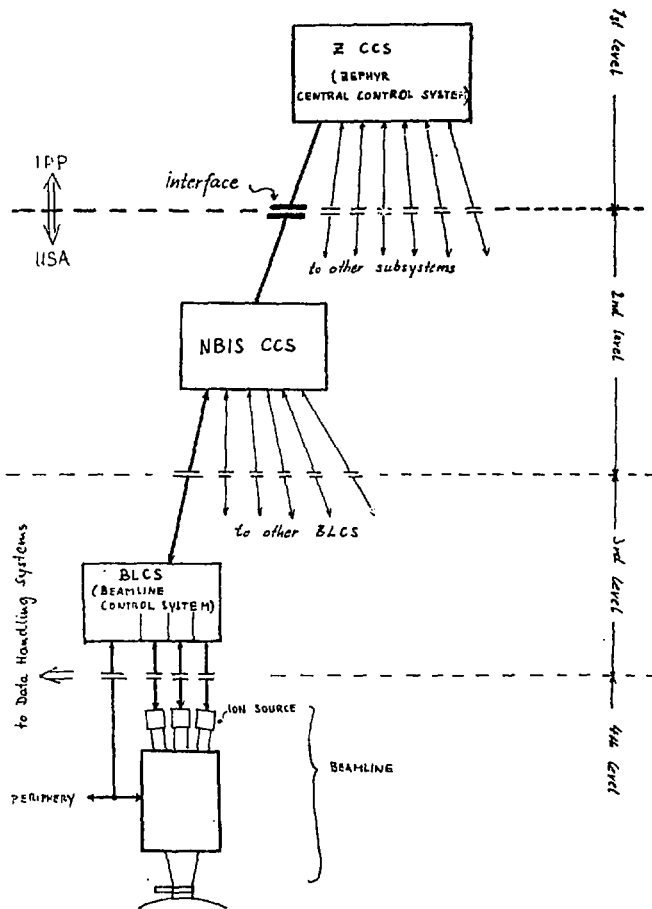

Fig. 3.9.1

APPENDIX C: DETAILED CIRCUIT DESCRIPTION OF
ACCEL POWER SUPPLY OPERATION

A simplified diagram of the accel/gradient grid PS is shown in Figure C-1. A 12-pulse rectifier has been chosen to minimize the ripple-filtering burden as well as the magnitude of the ac line current harmonics. The two oppositely-phased extended-delta secondary windings do the following:

1. provide necessary 30° phase shift for producing 12-pulse output ripple,
2. provide a closed winding circuit for third-harmonic currents to flow,
3. provide complete symmetry of winding turns-ratios and leakage reactance in order to obtain near-ideal 12-pulse ripple (theoretically of 3.5% pk-pk amplitude).

This secondary winding configuration was chosen over other alternatives such as wye-delta, polygon, and zig-zag windings principally because of (2) and (3), above. Additionally, the polygon arrangement has the disadvantage of requiring windings on the same core leg to be at markedly different voltages. The rectifier transformer will be rated for 12 MVA (pulsed), 3 MVA (cw) duty. Referring to the figure, the full winding voltage is

$$V_w = V_x + V_y .$$

For proper 30° phase shift:

$$V_x = \sqrt{3} V_y .$$

The line-to-line RC networks, R1 - R6 and C1 - C6, are standard spike filters and aid in smoothing commutation notches.

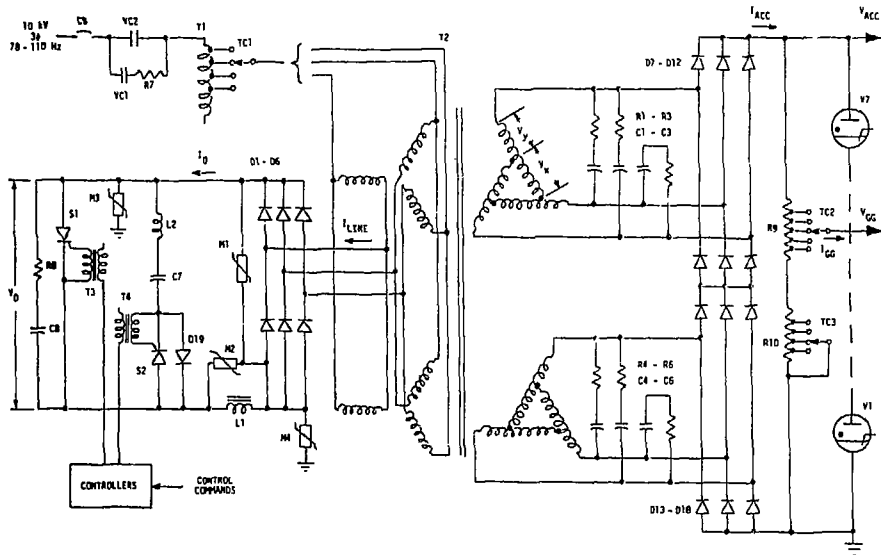

XBL 814-9191

Fig. C-1 Simplified schematic diagram of accel power supply

R9 and R10 make up the gradient grid PS. R10 is a coarse range-control, necessary to keep I_{gg} in the few-ampere range even when V_{acc} is at the low end of its range. R9 is the fine V_{gg}/V_{acc} ratio control. R9 and R10 are adjusted by programmable stepping-motor drives and properly coordinated with V_{acc} to produce the desired V_{gg}/V_{acc} ratio.

Ignitrons V1 - V7 make up the crowbar. This will be triggered each time a NB source spark occurs and at the end of the pulse.

The rectifier transformer has two sets of primary windings, electrically connected in parallel, one under each of the two secondary windings. This arrangement minimizes leakage reactance, but more importantly it avoids extremely large axial forces between the windings on a core leg which would be produced if only a single primary winding were used. Since the two sections of the secondary windings have different currents flowing in them, each section must consist of an integer number of layers in order to avoid large axial forces.

The neutral, or star, points of the primary windings are connected to a 3 ϕ diode bridge rectifier. Such a circuit makes it possible to control a large amount of ac power by dc techniques and with a response time that is short compared to the ac line period. The 3 ϕ bridge rectifier and its associated circuitry make up the SPC. It has three main components:

1. a series SCR string (S1) which, when triggered, turns on the PS;
2. another series SCR string (S2), always triggered at the same time as the crowbar, which commutates S1, then itself, turning off the PS;

3. a dc choke (L1) with an inductance in the 10 mH range.

This choke serves several purposes.

1. It provides HVDC ripple filtering.
2. It limits the rate of rise of current into any HVDC fault, including crowbaring, so that by the time S1 and S2 open the primary circuit (in typically <100 μ sec), the increase in primary current is negligibly small. This is a very important consideration; it results in transformer and rectifier diode lifetimes which can be rated in millions of pulses while using standard, economical transformer winding techniques.
3. It provides filtering for notches which exist on the ac supply lines as a result of TF coil PS transient loading.

It also has the undesirable effect of limiting output risetime at turn-on.

A common alternative method for limiting short-circuit currents is to build up the power supply impedance by a combination of higher transformer leakage reactance and added line reactance. However, this has the disadvantages of "softening" the supply, producing poorer regulation, and leading to an unacceptable increase in V_{acc} as the MG bus frequency decreases during the shot. A power supply having the current-limiting inductor L1 in the SPC has the intriguing property of being "stiff", i.e., having relatively low impedance, during normal operation while being "soft" and effectively limiting currents during faults.

The SPC switching and commutation circuit arrangement has been chosen for reasons of simplicity, economy, and reliability. The

latter is judged by our experience using essentially the same technique for switching large accel PS's in the HVDC secondary circuit.

An alternative configuration which was considered had S_{UK} 's replacing the bridge rectifiers D1 - D6. This had the advantage of permitting phase-controlled regulation but was judged more expensive than the chosen approach. Most importantly, following a crowbar, primary current in such a circuit would not cease for a significant fraction of a line period. This would likely result in an $I_{peak}/I_{operate}$ current ratio of 2 or more, a condition which can seriously compromise transformer life. Increasing the dc choke size to limit this only worsens the risetime. Pre-charging the inductor with a separate current supply could solve the problem. However, since regulation is not needed for the present task, the simpler circuit, compatible with a smaller choke, has been chosen.

In Figure C-1, L2 and C7 form the commutating network. C2 is charged through D20 to the SPC voltage V_D . Assuming S1 has been conducting and S2 is triggered, C2 discharges through L2 and S1 in a ringing oscillation. For the first half-cycle, current through S1 is therefore increased. During the second half-cycle, voltage across S1 reverses and it ceases to conduct after its commutation delay (typically $<40 \mu\text{sec}$) expires. Deprived of its current source, S2 also commutates and C7 is recharged to V_D . Any failure to commutate S1 because of circuit malfunctions would be detected by fault-sensing circuits. These would cause the primary vacuum contactors VC1 and VC2 to open. R8 and C8 form a "keep-alive" circuit to ensure that S1

becomes fully conducting, when triggered, since L_1 limits the initial current flow.

Even though the primary can be opened in $<100 \mu\text{sec}$, current still flowing in the transformer leakage reactance may flow longer while the stored energy it represents is dissipated. With I_D interrupted, this reactance generates an $L di/dt$ voltage while the current is decaying. The peak voltage is clamped by the varistor M_1 . This component is thus a relatively small but important device. It is fabricated from power-distribution grade lightning arrestor material of the zinc oxide type. It is adequately cooled and sized so it can dissipate energy in the several-kJ range during each interrupt. The energy stored in L_1 is also several kJ. M_2 clamps the voltage and dissipates this energy, when interrupts occur, in the same manner as M_1 . The peak voltage permitted by M_1 and M_2 will be restricted to $<1.5 V_D$ and this affects the specification of the transformer primary winding insulation.

At maximum rated output with the top tap of T_1 supplying 16 kV to the rectifier transformers, analysis shows that $V_D \approx 13.6 \text{ kV rms}$ before S_1 is triggered. When S_1 is conducting, $I_D \approx 840 \text{ ADC}$ and $I_{\text{line}} \approx 618 \text{ A}_{\text{rms}}$. At a later stage in the project, a cost optimization study would have been conducted to choose the optimum transformer primary voltage, trading off T_1 and T_2 costs vs SPC costs. At least one manufacturer markets series assemblies of 4000 V, 3000 A SCR's. It is conceivable that we could take better advantage of SCR's large current capability to lower overall costs by going to a system with a lower voltage and higher current primary circuit.

Finally, the SPC receives transformer-coupled trigger signals from a "smart" controller. This device causes the PS to turn on or off properly in response to local or remote control commands received from the LCS. It also receives turn-off commands directly from NB source and PS fault-sensing circuits.

The proposed accel PS and SPC configuration has been breadboard-tested at low power on the bench. Because a transformer with dual extended-delta secondary windings was unavailable, two other transformers were used. These were matched in all respects except that one had a wye secondary and the other had a delta secondary. Their rectified outputs were connected in series. Their primaries were paralleled and connected to the SPC. The circuit performed in the manner described above with no problems or unanticipated transients being generated, either within the SPC and transformer windings or to ground.

The next step would be to test the circuit at a few-kilovolt, few-kW level with the proper extended delta windings. Particular attention would be paid to the correct scaling of the per-unit impedance and leakage reactance. Uncertainties about the necessary choke (L1) size and the output risetime would be resolved. In case the risetime is excessive, a back-up plan exists for pre-charging the choke, L1, by an isolated power supply, thereby eliminating the "filling time" of the inductor from the risetime.

Three items of related experience are of interest. The LBL 120 kV, 75 A, 1.5 sec accel PS has an output risetime (0 - 90%) of <10msec. At IPP, a multimewatt 140 kV NB power supply¹ is in operation (as of this date, at a ~30 kV level) which has thyristor-

bridge star point controllers and pre-charged inductors in the SPC. In 1977, the JET design group proposed² that their 200 kV, 25 MW NB PS's have thyristor-bridge star point controllers and inductors in the SPC.

References

1. D. Hrabel, et al., "HV-Power Supply For Neutral-Injection Experiments Wendelstein VII and Asdex", Proceedings of the 8th Symposium on Engineering Problems of Fusion Research, IEEE Pub. No. 79CH1441-5NPS, November 1979, p. 1005.
2. P.L. Mondino and K.I. Selin, "JET Additional Heating Power Supply and Protection", Proceedings of the 7th Symposium on Engineering Problems of Fusion Research, IEEE Pub. No. 77CH1267-4NPS, October 1977, p. 1558.