

251  
8/17/81

DR 2880  
2951

**GEND**

008

**MASTER**

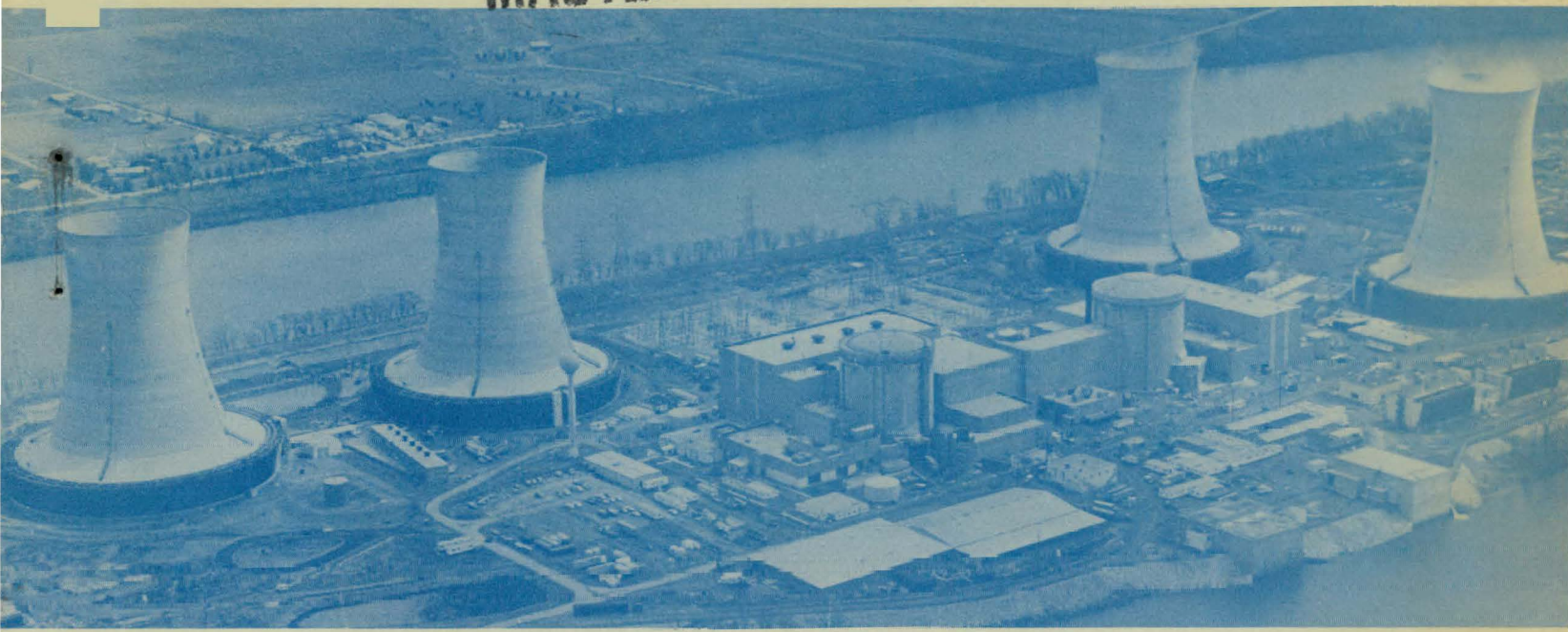

**GEND**

General Public Utilities • Electric Power Research Institute • U.S. Nuclear Regulatory Commission • U.S. Department of Energy

# The Citizen Radiation Monitoring Program for the TMI Area

Anthony J. Baratta  
Barbara G. Gricar  
William A. Jester

July 1981

Prepared for the  
U.S. Department of Energy  
Three Mile Island Operations Office  
Under DOE Contract No. DE-AC07-76IDO1570

DISTRIBUTION OF THIS DOCUMENT IS UNLIMITED

## DISCLAIMER

**This report was prepared as an account of work sponsored by an agency of the United States Government. Neither the United States Government nor any agency Thereof, nor any of their employees, makes any warranty, express or implied, or assumes any legal liability or responsibility for the accuracy, completeness, or usefulness of any information, apparatus, product, or process disclosed, or represents that its use would not infringe privately owned rights. Reference herein to any specific commercial product, process, or service by trade name, trademark, manufacturer, or otherwise does not necessarily constitute or imply its endorsement, recommendation, or favoring by the United States Government or any agency thereof. The views and opinions of authors expressed herein do not necessarily state or reflect those of the United States Government or any agency thereof.**

## **DISCLAIMER**

**Portions of this document may be illegible in electronic image products. Images are produced from the best available original document.**

Printed in the United States of America

Available from  
National Technical Information Service  
U. S. Department of Commerce  
5285 Port Royal Road  
Springfield, VA 22161  
NTIS Price Codes: Printed Copy A18  
Microfiche A01

#### DISCLAIMER

This book was prepared as an account of work sponsored by an agency of the United States Government. Neither the United States Government nor any agency thereof, nor any of their employees, makes any warranty, express or implied, or assumes any legal liability or responsibility for the accuracy, completeness, or usefulness of any information, apparatus, product or process disclosed, or represents that its use would not infringe privately owned rights. References herein to any specific commercial product, process, or service by trade name, trademark, manufacturer, or otherwise, does not necessarily constitute or imply its endorsement, recommendation, or favoring by the United States Government or any agency thereof. The views and opinions of authors expressed herein do not necessarily state or reflect those of the United States Government or any agency thereof.

# THE CITIZEN RADIATION MONITORING PROGRAM FOR THE TMI AREA

Anthony J. Baratta  
Barbara G. Gricar  
William A. Jester

Published July 1981

Pennsylvania State University  
University Park, Pennsylvania 16802

**DISCLAIMER**

This book was prepared as an account of work sponsored by an agency of the United States Government. Neither the United States Government nor any agency thereof, nor any of their employees, makes any warranty, express or implied, or assumes any legal liability or responsibility for the accuracy, completeness, or usefulness of any information, apparatus, product, or process disclosed, or represents that its use would not infringe privately owned rights. Reference herein to any specific commercial product, process, or service by trade name, trademark, manufacturer, or otherwise, does not necessarily constitute or imply its endorsement, recommendation, or favoring by the United States Government or any agency thereof. The views and opinions of authors expressed herein do not necessarily state or reflect those of the United States Government or any agency thereof.

Prepared for EG&G Idaho, Inc.  
Under Subcontract No. K-9004  
And the U.S. Department of Energy  
Under DOE Contract No. DE-AC07-76ID01570

## ABSTRACT

As early as the summer of 1979, concerns were expressed by local officials and citizens around Three Mile Island (TMI) regarding radiation levels and clean-up operations at TMI. In response to these concerns, the Department of Energy (DOE) requested the Pennsylvania State University (PSU) and the Pennsylvania Department of Environmental Resources (DER) to cooperate with the U.S. Environmental Protection Agency and citizens in the TMI area to develop a Citizen Radiation Monitoring Program.

The purpose of the Program was to develop a system for citizens to independently measure radiation levels in and around their communities. This report describes the process by which the Program was developed and operated. It also presents the methods used to select and train the citizens in making and interpreting the measurements. The test procedure used to select the equipment for the program are described as are the results of the testing. Finally, the actual monitoring results are discussed along with the citizens' reactions to the program.

## ACKNOWLEDGMENTS

This project would not have been possible without the support and assistance of the following organizations:

The U.S. Department of Energy  
The Pennsylvania Department of Environmental Resources  
EG&G Idaho, Inc.  
The U.S. Environmental Protection Agency  
The Pennsylvania State University

In addition, the following people deserve special appreciation for their contribution:

Margaret A. Reilly  
Greg R. Eidam  
Erich E. Bretthauer  
Al Smith  
Willis A. Bixby  
Willis Corchoron

Special recognition should also be given to the citizens of the TMI area.

## CONTENTS

Summary

- I. Background
- II. Program Design
- III. Training
- IV. Monitoring Operations
- V. Community Assumption of Responsibility
- VI. Results
- VII. Recommendations and Conclusions

Appendix A - Monitoring Equipment Test Report

Appendix B - Training Program Outline, Handouts, and Tests

Appendix C - Program Operating Procedures

Appendix D - Reporting Forms and Results

Appendix E - Monitors' Responses to Questionnaires



## SUMMARY

Following the accident at the Three Mile Island Nuclear Generating Station (TMI) on March 28, 1979, efforts by the government and the utility to inform the public about the accident and the clean-up activities were impeded by a strong public mistrust, created partly by the organizations themselves and partly by the emotional nature of the events themselves. Federal, state, and local agencies experienced serious problems of credibility. In the face of this public mistrust, alternative methods were required to provide reliable technical information to the public in a credible and understandable manner about the consequences of the accident and the clean-up of the damaged reactor.

It is the purpose of this paper to describe one such approach that was used to accomplish this task in the area surrounding TMI. Specifically, the U.S. Department of Energy (DOE), in cooperation with local citizens, the Pennsylvania Department of Environmental Resources (DER), The Pennsylvania State University (PSU), and the U.S. Environmental Protection Agency (EPA), undertook the development of a Citizen Radiation Monitoring Program. The program provided a means for citizens in the TMI area to independently measure and thereby verify radiation levels, and as a result educate themselves about radiation and the radiation levels in their communities.

### Background

The most serious commercial nuclear accident occurred at the Three Mile Island Nuclear Generating Station-Unit 2 (TMI-2). As a result of the accident, the plant was extensively damaged. Although the reactor is shut-down, there are large amounts of radionuclides trapped in the containment. Cleanup and removal of this material is required to allow disassembly of the damaged reactor.<sup>1,2</sup>

The first step in the cleanup process was the decontamination of the TMI-2 containment atmosphere, which involved removal of 44,000 curies of krypton-85 along with smaller quantities of other radionuclides.<sup>3</sup> The process was carried out through a purge of the containment. As a result, the krypton-85 was vented in a controlled manner to the environment:

Prior to the purging, residents of the area were concerned about the release of the krypton-85 from containment and its potential impact on public health. At public meetings on TMI, residents repeatedly stated their fears over potential dangers associated with the planned release

and requested their own radiation detection system to monitor radiation levels in their communities. As early as five months after the accident concerned citizens and county officials in Lancaster County (located less than 2 miles from TMI) initiated inquiries about a system equipped with remote radiation monitoring capability. The system would measure radiation levels in Lancaster County independently of measurements by the Nuclear Regulatory Commission (NRC) and the Utility (Met Ed). This effort was abandoned after County officials discovered the cost of the system would be excessive.<sup>4</sup>

The Governor's Report on Three Mile Island also pointed to the need for an independent monitoring program.<sup>5</sup> This report suggested that DER design and implement a pilot community radiation monitoring program.

In response to these various community requests, the Department of Energy called together representatives of seven organizations to explore the feasibility of developing a community monitoring effort. The organizations included the Pennsylvania Department of Environmental Resources, the Pennsylvania State University, EG&G Idaho (a DOE contractor charged with TMI-related research), the Environmental Protection Agency, DOE representatives, the NRC, the Metropolitan Edison (the Utility). In early March 1980, a decision was made to explore the idea of a Citizen Radiation Monitoring Program with local county and community Officials.

#### Program Concept

The primary purpose of the Citizen Monitoring Program was to provide a source of accurate and credible information concerning radiation levels in and around TMI to the local citizens. The Program trained local citizens to perform and evaluate radiation measurements and to report their findings to their communities. The Program was, in essence, an independent routine radiation surveillance program operated by the local citizenry.

Based on discussion with local officials, twelve communities were selected to participate in the Program. These communities are identified in Figure 1. Drawing on previous contacts that DER had with many of the communities, DER, DOE, and PSU representatives visited first county and then local township officials to solicit input and support for the Program.

Local officials from each of the twelve communities were then asked to nominate three to five citizens to participate in the Program. Fifty-one were nominated. These individuals were placed in a comprehensive three-week training program described later.

### Program Management

A technical working group (TWG) consisting of representatives from DER, PSU, EPA, and EG&G was organized to oversee development and operation of the Monitoring Program. The purpose of the TWG was to develop the necessary procedures and structure for Program implementation, conduct the training, and manage the Program during the operational phase. The TWG provided periodic briefings to local community leaders, the NRC, the Utility, and the press about the status and activities of the Program.

### Equipment Selection

Once the Citizen Monitoring Program was conceived, several major decisions had to be made. One of these involved the selection of the equipment to be used for the actual monitoring. There was considerable disagreement among TWG members about which radiation monitoring system should be used. Since the system would be first utilized during the controlled release of the krypton-85 from the containment, the decision was made to test the various systems for ease of operation and sensitivity to krypton-85. The Pennsylvania State University tested twelve instruments currently available for radiation monitoring.

The instruments tested included a Reteur Stokes pressurized ionization chamber, a Learsiegler ionization chamber, a Kimmel plastic scintillation detector, Eberline HP 260, HP 210, and HP 27 GM probes, and an Eberline PAC-46 Proportional Counter with AC21B beta probe.<sup>6</sup> Each instrument was immersed in a tent containing krypton-85 at a concentration of approximately  $67 \times 10^{-7}$   $\mu\text{Ci/cc}$  or 22 times the unrestricted allowable concentration of  $3 \times 10^{-7}$   $\mu\text{Ci/cc}$  of 10 CFR20, Appendix B. The most sensitive device was found to be the Eberline PAC-4G with the AC21B beta probe. The HP 210 and 260 GM probes were found to also have a sensitivity to the beta radiation from krypton-85. The least sensitive were the various ionization chambers.

Because of its ruggedness, the HP 260 probe with a Ludlum ratemeter was chosen for the Program. The minimum measured krypton-85 sensitivity for this probe was about  $1 \times 10^{-7}$   $\mu\text{Ci/cc}$ . Since GM tubes are sensitive to gamma radiation in addition to beta radiation, it was decided to also equip each monitoring site with a Learsiegler ionization chamber (LSI), which is sensitive only to gammas. Use of the two instruments allowed measurement of both beta and gamma radiation levels and dose.

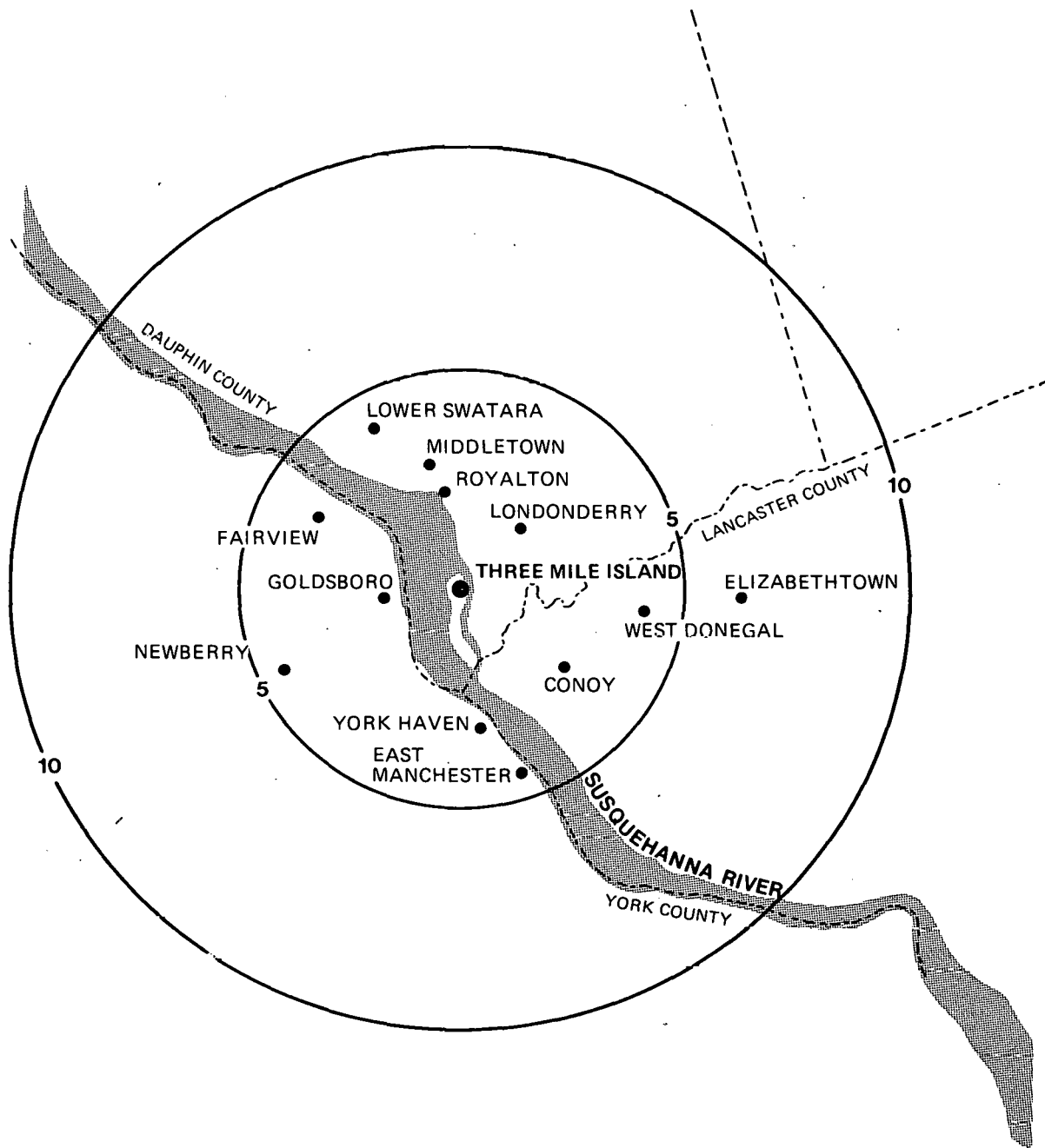

FIGURE 1

## Training

The training program was designed to introduce participants to basic concepts about radioactivity and to equip them to make radiation measurements and to interpret the results. As expected, it was found that the participants had little or no formal training in nuclear science or radiation detection fundamentals. Most were high school educated and employed in a non-technical position.

To accomplish the needed education, the training program was divided into two parts. The first part provided a fundamental course in nuclear science. It consisted of lectures on nuclear and atomic structure, fundamentals of radioactivity, natural sources of radiation, interaction of radiation with matter, fundamentals of gas-filled detectors, radiation dose units, and the biological effects of radiation. Also included in this part of the program was laboratory work in radiation, its interaction with matter, radiation protection and health physics, and counting statistics. The second portion of the training program provided specific training for the monitoring task. It consisted of lectures on the TMI accident, krypton-85 disposal methods, and gaseous plume dispersal. Hands-on experience with the radiation detection equipment was provided throughout the program. Table 1 provides an outline of the course topics.

The training program was structured in this manner to allow the participants to be conversant in radiation terminology and capable of not only recording but interpreting and explaining the results as well. In this way, the citizen monitors could interpret the results for others in their communities, thereby providing a more credible source of information for the residents than government reports.

The training was accomplished in an 11-session, 36-hour course. The course was taught at the Middletown Campus of PSU located about 5 miles from TMI. In addition, the participants attended a one-day laboratory session at the Breazeale Nuclear Reactor located on the PSU University Park Campus.

## Program Operation

Once the training of the residents was complete, the Program began to collect data on a regular basis. Each of the twelve communities operated a station equipped with a gamma sensitive Learsiegler Ionization Chamber and a beta sensitive Ludlum GM detector

TABLE I

Topical Outline for Training Participants  
for the Citizen Radiation Monitoring Program

DAY		TIME
1	A. Introduction to the Citizen Radiation Monitoring Program	3 hours
	B. Radioactivity	
	1. Introduction and Definition of Terms	
	2. Radioactive Decay	
	3. Conservation Laws	
	4. Background Radiation and Sources	
2	C. Interaction of Radiation with Matter	1.5 hours
	1. Introduction and Definition of Terms	
	2. Interaction Mechanisms	
	D. Methods of Radiation Detection	1.5 hours
	1. Introduction and Definition of Terms	
	2. Detector Types	
	3. Detector Sensitivities	
3	E. Radiation Counting Variables	1.5 hours
	1. Introduction and Definition of Terms	
	2. Systematic and Statistical Variables	
	F. Laboratory Experiment	1.5 hours
	GM Counting Experiment	
4	G. Radiation Protection Units	1.5 hours
	1. Activity	
	2. Exposure Dose	
	3. Absorbed Dose	
	4. Equivalent Dose	
5	H. Laboratory Experiment	6 hours
	1. Monitoring Equipment	
	2. Familiarization and Krypton-85 Monitoring	
6	I. Radiation Interaction in Biological Systems	1.5 hours
	1. Introduction and Definition of Terms	
	2. Radiation Effects	
	3. Regulations	

DAY		TIME
	J. Laboratory Experiment Counting Statistics Laboratory	1.5 hours
7	K. Citizen Radiation Monitoring Program 1. Purpose 2. Organization 3. Equipment 4. Procedures	1.5 hours
	L. Three Mile Island Unit-2 1. The Accident 2. Proposed Methods of Cleanup	1.5 hours
8	M. Supervised Area Monitoring	3 hours
9	N. Supervised Area Monitoring	3 hours
10	O. Final Exam	1.5 hours
	P. Discussion of Community Radiation Monitoring Results and Observations	1.5 hours
11	Q. Meteorological Considerations 1. Introduction and Definition of Terms 2. Atmospheric Conditions Affecting Dispersion	1.5 hours
	R. Assignment of Personnel to Local Monitoring Teams	1.5 hours

The radiation levels were recorded on strip chart recorders. Each day the participants examined the charts and recorded high, low, and average readings for the day on forms developed specifically for use with the Program. The forms from each of the twelve communities were collected daily by a DER representative. DER personnel reviewed the data, summarized it, and distributed the results to the press, NRC, EPA, and twelve communities involved, and other state and federal agencies.

During the period from May 23, 1980 to June 28, 1980, the data<sup>7</sup> consisted of background radiation levels in and around the area. This pre-purge data was used to establish baseline data for background levels at each of the monitoring sites.

The purging of the TMI-2 containment began on June 28, 1980 and continued through July 11, 1980. Each day the charts were checked for readings above background. Positive readings on the Ludlum GM detection system and none on the LSI system indicated the presence of krypton-85 in the area. Such indications occurred at a minimum of one station on 10 of the 12 days during the purging.<sup>7</sup> Krypton-85 was detected at least once at 10 of the 12 stations. The data for the purge period is summarized in Table II. This data is generally consistent with data produced by other organizations during the purge.

#### Evaluation

A questionnaire to the participants and interviews with local community leaders, the participants, and state and county officials suggested that the Program was successful in developing a credible source of information. The Program provided simple, yet technically accurate, information on radiation levels in each community in a manner that was accepted by the residents. In fact, the Mayor of Middletown recently stated that this Program was one of the most significant activities that helped alleviate tension during the krypton-85 purging.

#### Recommendation

While overall, the program was deemed successful, a number of problems were noted and should be corrected. These problems and the action needed to resolve them are as follows:

- <sup>o</sup>The Program should encourage community input into and responsibility for the design and implementation. That is, local officials and



Table II

Summary of Community Monitoring Data for the<sup>7</sup>  
 Reactor Building Purge (6/28/80-7/11/80)

## CMP Station Locations

<u>Municipality</u>	<u>Azimuth</u>	<u>Distance (mi)</u>	<u>Integrated Total Skin Dose (mrem)</u>	<u>Max Skin Dose (mrem)</u>
Londonderry	40°	1	0.105	0.056
Elizabethtown	90°	6.5	0.015	0.015
West Donegal	100°	7	0.011	0.011
Conoy	160°	2	0.036	0.015
East Manchester	170°	7	ND	ND
York Haven	175°	3	0.041	0.037
Newberry	245°	4.5	0.003	0.003
Goldsboro	270°	1.5	0.004	0.004
Fairview	285°	7	ND	ND
Lower Swatara	335°	2.5	0.006	0.006
Middletown	350°	2	0.030	0.014
Royalton	355°	2	0.087	0.025

citizens should participate in the initiation and planning of the Program as well as in its implementation. Such participation will increase the likelihood that the Program is responsive to community needs, promote community understanding of what the Program is trying to achieve, and facilitate eventual transfer of responsibility for the Program to the community once it is operational. Implementation of this recommendation involves efforts by the sponsors to build such participation into the Program design from the outset.

○ Considerable reliability problems occurred with some of the instrumentation. To avoid these problems in future programs, a comprehensive environmental and reliability program should be undertaken to identify reliable instrumentation suitable for such programs.

○ Among the participants in the Program there was a clear lack of understanding regarding the basics of radiation, radiation effects, and radiation detection. Insofar as the participants are representative of residents near a nuclear power plant, there appears to be a need for increased educational efforts in areas surrounding such facilities.

○ Some difficulty was encountered regarding the specific role assignments of the organizations comprising the TWG. To minimize this problem in future programs, time and effort should be devoted to team development activities, with particular emphasis on clarification of roles and coordination mechanisms. Similar team development should be conducted with the monitoring team from each community to encourage a cooperative spirit and to insure that the monitoring work was distributed evenly among the participants.

○ Because the media were already receiving reports from other government agencies and the utility, they were reluctant to report the results of the Monitoring Program. As a result, some news outlets did not report the program's findings. To alleviate this problem, the media should be better advised as to the significance of the effort. In addition, they should be invited to participate early in the design, development, and operation of such programs.

## References

1. M. Rogovin; Three Mile Island a Report to the Commissioners and the Public, NTIS, January 1980.
2. "Planning Study for Containment Entry and Decontamination," Bechtel Power Corporation, July 1979.
3. Environmental Assessment for Decontamination of the Three Mile Island Unit 2 Reactor Building Atmosphere, NUREG-0663, NTIS, March 1980.
4. Interim Report #2. Proposal for the Establishment of an Early Warning Nuclear Detection System for Lancaster County. W. D. Connors Lancaster County, Emergency Management Division, Lancaster, PA August 21, 1979.
5. Report of the Governor's Commission on Three Mile Island, Commonwealth of PA, February 1980.
6. W. A. Jester, et al. "Evaluation of Radiation Monitor Effectiveness for the Detection of Krypton-85," Trans ANS, Vol. 35 (November 1980).
7. M. A. Reilly, "The Measurement of Kr-85 by a Community Monitoring Program," Trans. ANS, Vol. 35 (November 1980).

## INTRODUCTION

This report describes the Citizen Radiation Monitoring Program, designed to provide an independent and credible source of information about radiation levels to citizens in the communities adjacent to the Three Mile Island Nuclear Generating Station (TMI). The Program was the first of its kind and represented a unique effort to foster citizen confidence in public information.

### I. BACKGROUND

#### Aftermath of the accident at Three Mile Island

The most serious commercial nuclear accident in the world occurred at (TMI) on March 28, 1979. This event, coupled with a number of other compounding technical and human errors, created a nuclear emergency which culminated in an estimated, release of 2.5 million Curies of radioactive gases into the atmosphere.<sup>1</sup> The President's Commission on the Accident at TMI identified no immediate or expected long-term physical health effects to the citizens from the accident.<sup>2</sup> They did identify an immediate short term psychological health effect. In addition, the potential danger associated with the crisis was substantial.<sup>1</sup>

Following the accident, large quantities of radionuclides remained in the containment building and reactor core. Removal of these materials will require extensive cleanup and decontamination efforts over the next several years. The first major step in the cleanup effort required decontamination of the reactor containment building atmosphere. The technical consensus favored controlled purging of the radioactive krypton-85 to the atmosphere.

The NRC staff concluded that the purging would not endanger the health and safety of the public.<sup>3</sup> However, much of the public did not totally accept this conclusion. The lack of acceptance stemmed from public mistrust of the utility and of the federal, state and local agencies involved in regulating and monitoring the clean-up. This feeling of distrust can be attributed to (1) a lack of basic scientific and technical knowledge about radiation among the public and (2) the belief among many citizens that initial reports about the accident were deliberately misleading. For example, the Report of the Governor's Commission on TMI,<sup>4</sup> attributed the psychological stress associated with the accident to a lack of credible

scientific information on which residents of the area could rely. Such stress is exacerbated by general lack of understanding among the local population as to what radiation is, how to measure it, and what health effects can be expected from exposure to it. Attempts by the NRC, Metropolitan Edison (Met Ed), the utility which operates TMI, to provide information to people about safety had been largely ineffective and at times had antagonized people living in the area. The NRC's own special inquiry group concluded.

It's clear to us that the public misconception about risks associated with the actual releases measured during the accident, as well as about the risks associated with nuclear power plants generally, has been due to a failure to convey credible information regarding the actual risks in an understandable fashion to the public. We believe substantial efforts are necessary to provide such information.<sup>1</sup>

Public mistrust such as this originates from perceptions that activities of the NRC and Met Ed were solely motivated by their self-interest without consideration for the community.

#### Community Requests for Monitoring

As early as August of 1979 concerned citizens and county officials in Lancaster County (directly east of TMI) initiated inquiry to the Lancaster County Emergency Management Director about a remote radiation monitoring capability for measuring radiation levels. They sought a system for Lancaster County which would have been independent of measurements made by the NRC and Metropolitan Edison. In the fall of 1979 they sought and received technical assistance from the Pennsylvania Department of Environmental Resources (DER)<sup>5</sup>, but they abandoned their efforts after discovering that such a system would cost the county over \$100,000.

A separate, but similar initiative was launched by the Mayor of Middletown, a borough of 10,000 people located four miles north of TMI. In a letter to President Carter, the Mayor requested that an independent monitoring program be established by a government agency other than those already related to TMI. As a follow-up to this letter, residents of Middletown traveled to Washington, D.C. to meet with their congressman to express their desire for credible information about TMI and radiation levels in the area. In February, residents of Lower Swatara, just north of Middletown, lodged a similar request for a community monitoring program

with the Governor of Pennsylvania.

The Governor's Report on Three Mile Island<sup>4</sup> also pointed to the need for an independent monitoring program. Specifically, the Report recommended that the Pennsylvania Department of Environmental Resources design, implement and supervise a pilot community radiation monitoring program to ensure local officials and residents of having quick access to information on environmental radiation levels.

There were additional requests for an independent monitoring capability from frustrated and anxious citizens at TMI information meetings held by the Department of Environmental Resources in February 1980 and at a public hearing held by the NRC on March 19, 1980, in Middletown, Pa. The requests were epitomized by one citizen who exclaimed: I want a monitoring device in my yard and for my neighbors.<sup>6</sup> The purpose of the NRC's public hearing in Middletown was to present and receive comments on the NRC's Environmental Assessment for Decontamination of TMI's Unit 2 Reactor Building Atmosphere.<sup>3</sup> Instead, what resulted was a vivid demonstration of the community's lack of confidence in information from the government, and in particular from the NRC. Comments from two citizens at the meeting convey the community's skepticism:

Citizen 1: Why should we (sic) believe you when you've made such colossal mistakes already?

Citizen 2: We are facing questions which have not been faced elsewhere. When are we going to get some credibility? I want to believe you, but I don't.

Ironically, there was so little communication between government officials and public at this meeting that an announcement by the NRC that the government was already pursuing a community monitoring program fell on deaf ears.

## II. PROGRAM DESIGN

### Concept of the Citizen Radiation Monitoring Program

During February and March of 1980, in part as a response to these various community requests, the U.S. Department of Energy (DOE) convened a series of meetings among representatives from seven organizations to discuss the idea of a community monitoring effort around TMI. The organizations included the Pennsylvania Department of Environmental Resources (DER), The Pennsylvania State University (PSU), EG&G Idaho (contractor for DOE), The Environmental Protection Agency (EPA), DOE, The Nuclear Regulatory Commission

(NRC) and Metropolitan Edison (Met Ed). During these meetings the concept of the Citizen Radiation Monitoring Program was developed. The purpose of the proposed Program was to provide a source of accurate and credible information about radiation levels to citizens who live close to TMI. This information would permit citizens to make informed and independent judgments about the safety of radiation levels in their community and to verify radiation levels measured by existing state and federal agencies. The Program was to be in essence, an independent routine surveillance program operated by local municipalities. Sponsoring organizations for the Program included the U.S. Department of Energy, the Pennsylvania Department of Environmental Resources and the Pennsylvania State University. To achieve its purpose, six characteristics were built into the design of the Citizen Radiation Monitoring Program.

- (1) The Program provided an independent, community-based source of information. Radiation measurements were made and disseminated by local citizens themselves. Data was not derived from government agencies or the utility, in whom some residents had little trust.
- (2) The Program provided simple, but technically accurate information. The instruments were sensitive to radiation levels well below the limits of safe exposure to the public. To minimize confusion and the need for technical conversions, measurements were reported in units that already had public currency in the area.
- (3) The Program offered an immediate source of information. Radiation level measurements were available to any citizen around the clock at a public site in each township.
- (4) The Program was educational. During the three-week training course the citizen monitors learned enough about radiation and its effects to enable them to interpret the measurements they received in the field.
- (5) The Program created a forum for dialogue among scientists, citizens, and government officials on technical aspects of policy decisions. The dialogue which occurred in the classroom permitted the citizen monitors to air their concerns and to hear alternative explanations supported by factual information.

(6) Most importantly, the Program offered a credible source of information. Its credibility derived primarily from the fact that the citizens themselves made direct measurements of radiation levels and could report their findings directly to their neighbors. The data was not filtered through any other organizations for interpretation or modification. A second contribution to the Program's credibility is the fact that the organizations who sponsored the Program had some objectivity in the eyes of the community. None of them were directly linked with Met Ed or the NRC. The sponsoring organizations offered technical expertise on radiation and its effects and essentially served as consultants to the communities in developing their monitoring capability. The Program gained credibility as the citizens assumed responsibility for managing the details locally.

Since such a Program was the first of its kind, there was no precedent to follow in establishing it.

#### Design Issues

As a result, a number of basic issues needed to be addressed in designing the Program. The most significant issues are listed below.

How many monitoring sites should be established and where should they be located?

Specifically, this decision required determination of what area the monitoring program should serve and which communities should be included. Once a municipality was selected, a specific site for placement of the monitoring equipment had to be determined.

Who should do the monitoring and how should they be selected?

This decision required determination of the qualifications of the monitors themselves and the process by which they would be selected.

What kind of radiation monitoring equipment should be used by the citizens?

This issue required decisions about the sensitivity, durability, availability, reliability and cost of monitoring equipment.

How should the data be presented and disseminated to the public?

This decision required the design of a simple, yet technically accurate format for presenting the radiation-level data. It also required design of a process for collecting the data from the monitoring sites and transmitting it to the public in a timely and accurate fashion.



How will readings above normal background levels be handled?

This issue, dubbed "glitch management", involved design of a process by which abnormal readings could be verified and interpreted (as a real radiation field or an instrument malfunction) and appropriate agencies and the public notified without causing undue alarm or confusion within the area.

What kind of education and training should the citizens receive to prepare them to conduct the monitoring?

This issue required a judgement about the amount of theoretical background and practical experience that citizens should be given to ensure that they could accurately read and interpret the radiation monitoring equipment. It was also important to determine criteria for successful completion of the training.

What must be done by the organizations to establish and maintain the Program's credibility with the monitors themselves and with the general public?

In order to provide a credible information source for the general public, the sponsoring organizations needed to establish and preserve their own level of credibility with the participants.

The sections which follow provide specifics about how each of these issues was handled in the design and conduct of the program.

Community Input into the Program

In mid-March 1980 the sponsoring organizations decided to explore the feasibility of the proposed Program with municipal and county officials in the areas immediately adjacent to TMI and to solicit their input into the design of the Program. Judging from the expressed need for such a program and the availability of equipment, the sponsors decided to include the twelve municipalities (representing three counties) which fell within a five mile radius of the TMI plant. (See Figure 1).

DER, in its role in radiation protection for the State, had previously worked with many of the local communities. Therefore, DER arranged meetings between the sponsors and the commissioners of each county and local officials of the twelve municipalities. The meetings acquainted the officials with the Program concept and invited their input. These meetings also helped to establish local responsibility for the monitoring. Specifically, local officials were asked to nominate four citizens from their townships to receive training in radiation monitoring. In addition, they were asked how the Program could be useful to them and how it could best be designed

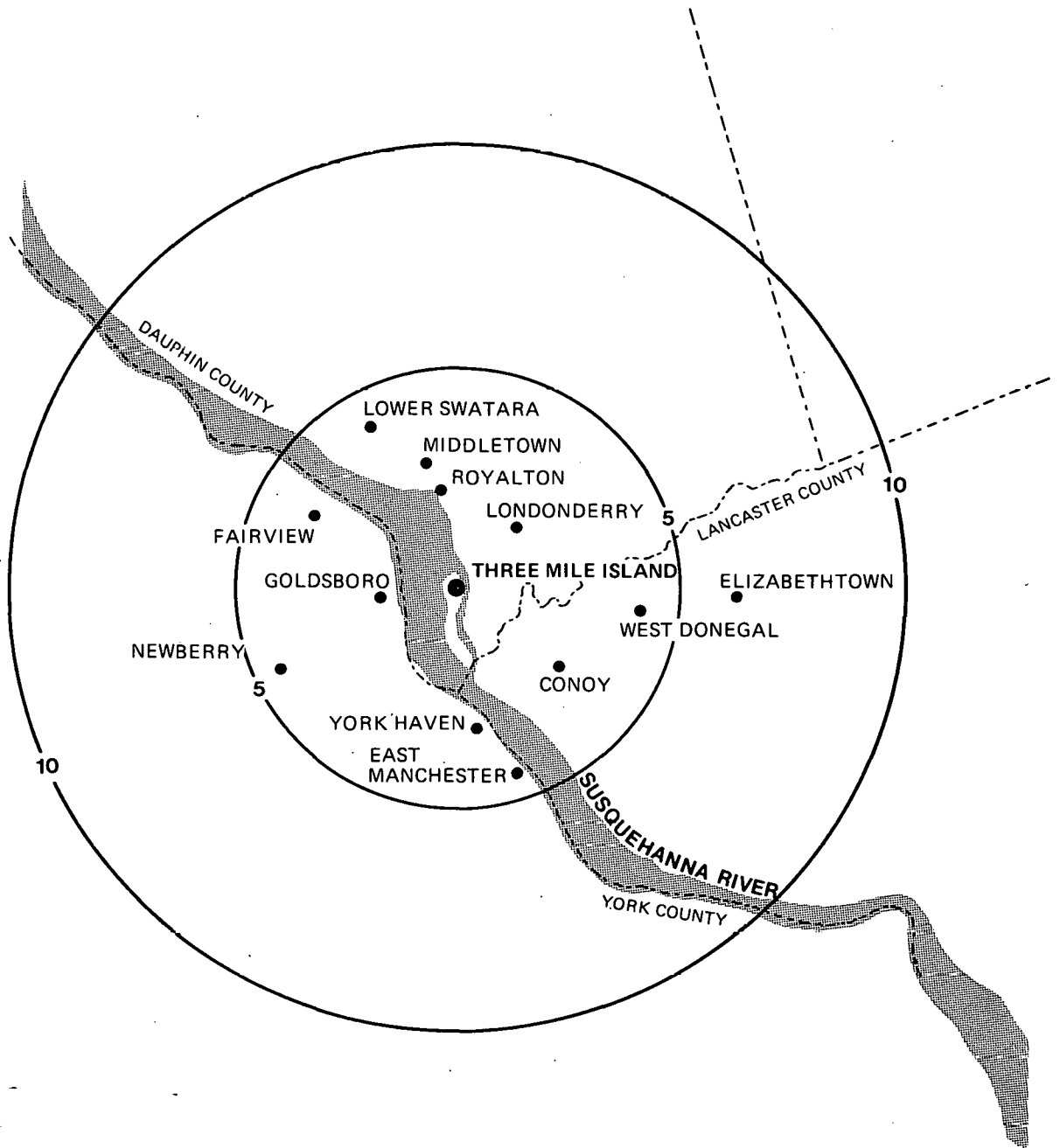

FIGURE 1

to ensure that timely and credible information was available to the citizens.

While most township officials reacted favorably to the concept of citizen monitoring, some were skeptical about whether it could really be done. They expressed concerns that the citizens could not be adequately trained to make accurate readings, that the data would be misused or reported incorrectly, and that the Program would generate conflicting reports about radiation levels, thereby amplifying existing confusion rather than providing a credible basis for citizens to judge the safety of radiation levels in their community.

#### Participants

Despite these concerns, all twelve municipalities agreed to participate in the Program. Local officials nominated fifty-one citizens to participate, approximately four from each township. Forty-eight of them were high school graduates. They had completed an average of one year of college. Roughly half had taken a course in chemistry or physics. Eleven had some previous training in radiation monitoring. They ranged in age from early twenties to senior citizens. Their occupations included a postal carrier, teachers, secretaries, police officers, engineers, housewives, and retirees.

#### Creation of a Technical Working Group (TWG)

To oversee the development and operation of the Program, a technical working group (TWG) was established. This group, comprised of representatives from four organizations (DER, PSU, EG&G Idaho and the EPA), spent many hours planning the overall Program, training the citizen monitors, designing the monitoring procedures, selecting the monitoring equipment, meeting with community leaders and generally overseeing the monitoring operation once it was underway in the individual communities.

### Selecting the Monitoring Equipment

Selecting the monitoring equipment to be used in the Program involved evaluating the sensitivities of various instruments to krypton-85. In addition, each type of equipment was examined for ease of operation and reliability. The evaluation was done by monitoring the argon-41 background radiation in the Penn State Breazeale Nuclear Reactor bay and by measuring krypton-85 levels in a specially-designed test room. Table 1 lists the equipment tested and the results.

As may be seen, only the thin window beta sensitive detectors, namely the GM pancake probes and the gas flow proportional counter, could detect the krypton-85 in the test room. None of the gamma sensitive detectors, such as the ion chambers, were sensitive enough to detect krypton-85 at the levels present in the test room. A detailed report of the tests and the results is contained in Appendix A.

As a result of this work, the Ludlum Model-177 ratemeter with an Eberline HP-260 pancake probe and Rustrak Model 288 recorder was chosen for use as a beta monitor in the Community Monitoring Program. In addition, the Learsigler, Inc. Model 131500 ion chamber (LSI) was chosen as a gamma detector. The rationale for using two instruments was to permit the detection of unforeseen abnormalities involving gamma emitters and to verify that during the purging, positive GM data would be attributable to krypton-85. Each station was equipped with these instruments. The Ludlum GM system was installed in a weather-tight enclosure.

The output of each instrument was to a strip chart recorder. The strip chart output allowed convenient identification of intervals by clock time allowing correlation of observed activity with predicted krypton-85 plume location. In addition, to allow reporting of estimated beta skin dose using the Ludlum GM system, a beta skin dose calibration factor was developed from the test room data. This calibration assumed the pancake probe to be immersed in a uniform infinite hemisphere of krypton-85. The calibration factor was determined to be between 0.6 and 1.0  $\mu\text{rem/hr/cpm}$ . Appendix A provides the details of the calibration.

### Designing a Training Program

As expected, the residents chosen for the Program had little or no formal training in nuclear science or radiation detection fundamentals.

Table 1

Test Instrument Sensitivity to Krypton-85 at  $6.7 \times 10^{-6} \mu\text{Ci/ml}$ 

Instruments Tested	Beta shield open		No beta shield or beta shield closed	
	Background	Kr-85	Background	Kr-85
	$\mu\text{R/hr}$	$\mu\text{R/hr}$	$\mu\text{R/hr}$	$\mu\text{R/hr}$
Ion Chambers				
Reuter Stokes, RSS-111 (Pressurized Ion Chamber)	NA <sup>(1)</sup>	NA	7-10	8-10
Learsigler, 131500-1 (Suitcase-type)	NA	NA	8-13	10-15
Eberline R0-2 (Portable Survey Meter)	100-500	300-700	100-500	100-500
Scintillation Detectors				
Kimmel, MAB604 (Plastic Scintillator)	3-6	13-16	3-6	5-7
Elliott Process Rate Meter, 1597A	NA	NA	5-8	6-8
	CPM	CPM	CPM	CPM
GM Detectors				
Eberline RM 14 ratemeter with Eberline HP 210 (Pancake Probe)	20-60	2000-2500	NA	NA

Table 1 (continued)

Instruments Tested	Beta shield open		No beta shield or beta shield closed	
	Background	Kr-85	Background	Kr-85
	CPM	CPM	CPM	CPM
Ludlum-2A rate meter with Eberline HP 210 and HP 260 (Pancake Probes)	20-80	2000-2200	20-60	100-140
Eberline MS2 with following probes:				
HP 210 (Pancake Probe)	20-60	1700-2500	20-60	140-200
HP 260 (Pancake Probe)	20-60	2300-2700	30-60	150-160
HP 270 (Energy Compensated)	20-30	40-100	20-30	20-30
Gas Flow Proportional Counter Eberline PAC-4G rate meter with Eberline AC21B Beta Probe	150-200	30,000-32,000	100-200	300-400

1 NA - Not applicable

2 Beta shield for GM detectors was a 0.3 cm aluminum absorber.

Therefore the training program was designed to provide sufficient education and training so that the citizen monitors could both make and interpret their readings.

Key issues in the design of the training program therefore were:

(1) How much background information in nuclear science did the participants need?, (2) What practical skills do the participants need to learn to read and interpret the monitors?, (3) At what level should the material be presented to insure that the participants could absorb it?, (4) What schedule should be adopted to encourage learning and still insure that the citizens were prepared before the start of the venting?, (5) What could be done during the training to enhance and maintain the Program's credibility with the participants and with the community?

To respond to these concerns, the training program was divided into two parts: the first provided a fundamental course in nuclear science consisting of lectures, and laboratory work in radiation, its interaction with matter, radiation protection and health physics, and counting statistics. The second portion of the training consisted of information about TMI's operation, the accident, as well as detailed discussions of the citizen monitoring procedures and hands-on experience with the radiation detection equipment. Such comprehensive training was not required for simply taking readings. However, since the task of recording the readings was only a part of the monitor's job, particular emphasis was placed on the ability to interpret and explain those measurements to his or her fellow residents. As a result, the training was designed to teach the participants enough fundamentals so they could be conversant in the subject and could practically apply those fundamentals to the monitoring activity.

Details of the training program's content and execution and staff effort to enhance credibility are described in Section III, Training. A topical outline of the course is included in Appendix B.

#### Designing a System for Collecting and Disseminating Information

The design for this part of the Program was one of the most difficult tasks to accomplish. The design addressed the following specific concerns.

1. Uniform procedures were needed across the twelve townships.
2. A minimum of filtering of the data by the citizens or by the TWG was needed to preserve credibility.
3. Rapid verification of the citizens' readings by the TWG was required to insure that the readings were accurate.

4. A process was needed by which TWG could be notified and citizen monitors could receive immediate technical assistance from the TWG in the event that an abnormal reading occurred.
5. Procedures were required for initiating and performing equipment maintenance.
6. Mechanisms were required to establish a central location for storage, summary and dissemination in a timely fashion.
7. The data needed to reach multiple outlets simultaneously. These included the TWG, the NRC, the EPA, and the local counties and municipalities.
8. The radiation levels needed to be reported in units that made sense to the general public.

With these considerations in mind, the overall information collection and dissemination system was developed. Figure 2 diagrams the flow of information from the monitoring sites to dissemination to the public.

The data collection procedures followed the general format described below. The citizens removed several feet of tape from strip chart recorders, determined the high, low and average reading for the completed 24-hour time period and recorded that information on a report form. Any comments or abnormal observations or equipment problems encountered were also recorded. Sample report forms appear as Figures 3 and 4. Citizen monitors (CM's) made readings at approximately 6:00 p.m. every day. Specific operating procedures for each piece of equipment were developed. A copy of these appears as Appendix C. While no one but the community monitors were permitted to operate the monitoring devices, local citizens could visually observe the readings at any time during the day or evening. The CM's signed, dated, and recorded the location and time of their reading. If the designated CM's did not make the readings and provide a daily monitoring report, no data was recorded for their community for that day. CM's were responsible, in conjunction with local officials, to determine a duty roster for the monitoring.

After the CM's made their readings they posted a copy of their daily report at the monitoring site for the public to observe. Each community determined if and where this data was to be made available.



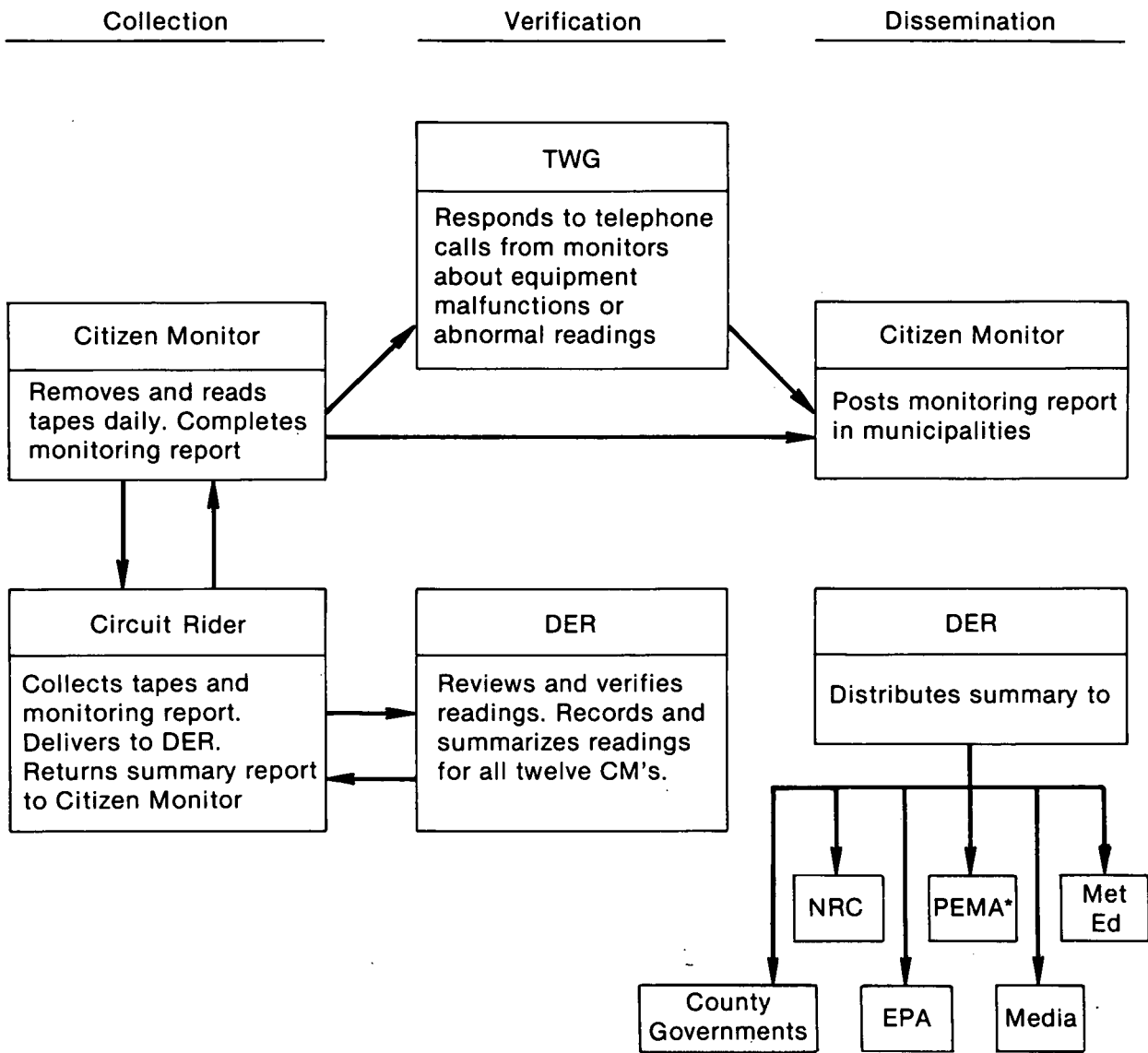

\*Pennsylvania Emergency Management Agency

FIGURE 2

CITIZEN RADIATION MONITORING PROGRAM

MONITORING REPORT

DATE

<u>LSI (Lear Siegler)</u>	<u>Eberline/Ludlum (Pancake)</u>
Time On: _____	Time On: _____
Time of Reading: _____	Time of Reading: _____
Daily High: _____ mr/hr	Daily High: _____ mr/hr
Duration: _____ minutes	Duration: _____ minutes
Daily Low: _____ mr/hr	Daily Low: _____ mr/hr
Duration: _____ minutes	Duration: _____ minutes
Daily Average: _____ mr/hr	Daily Average: _____ mr/hr

Comments:

\_\_\_\_\_  
\_\_\_\_\_  
\_\_\_\_\_  
\_\_\_\_\_  
\_\_\_\_\_  
\_\_\_\_\_

Signature: Citizen Recording Readings

Checked By:

FIGURE 3

CITIZEN RADIATION MONITORING PROGRAM  
MONITORING REPORT

FAIRVIEW TWP.

Date 6/16/80

<u>LSI (LEAR SIEGLER)</u>	<u>EBERLINE/LUDLUM (PANCAKE)</u>
Time on: <u>7:45 am</u>	Time on: <u>7:45 am</u>
Time of reading: <u>3:00 pm</u>	Time of reading: <u>3:00 pm</u>
Daily high: <u>.013</u> mr/hr	Daily high: <u>60 cpm</u> <del>mr/hr</del>
Duration: _____ Minutes	Duration: _____ Minutes
Daily low: <u>.008</u> mr/hr	Daily low: <u>10 cpm</u> <del>mr/hr</del>
Duration: _____ Minutes	Duration: _____ Minutes
Daily average: <u>.010</u> mr/hr	Daily average: <u>35 cpm</u> <del>mr/hr</del>

Comments: Normal background.  
High levels on Ludlum due  
to storm.

Signature: [Signature]  
 Citizen Recording Readings

Checked by: [Signature]

A circuit rider picked up the data (the strip charts and the CM's daily report) the following morning and delivered it to the DER offices in downtown Harrisburg for verification, documentation and dissemination. DER staff checked the readings, recorded them and prepared a summary of the results from all twelve monitoring sites. The circuit rider delivered the summary to each community during the following day's pick-up. Any errors noted in the readings were corrected by the DER staff. Copies of the corrected tapes were returned to the CM's. Otherwise, the original strip chart tapes from each of the local communities were retained by DER where they were available for inspection.

Periodic malfunctions of the radiation monitoring equipment did occur. Special procedures were provided to the CM's for these circumstances. See Appendix C for "In Case of Trouble" procedures.

The radiation monitoring equipment did periodically register readings above expected background levels. The CM's were trained to judge whether or not these readings represented significant abnormalities. For example, CM's were instructed to distinguish between instrument spikes and increases attributable to radiation sources.

If a significant, unexpected reading was discovered by the CM, he or she was instructed to immediately telephone a member of the TWG at a dedicated phone number. Additionally he or she was instructed to notify the local township official. If the unexpected reading was discovered by a local citizen or official other than a CM, that person was expected to contact a CM to verify and interpret the unexpected results. Once notified of an unexpected reading, the TWG gathered additional data as needed to determine the cause of the reading. This could require a visit to the site by the TWG representative, verification of the reading by mobile monitoring devices, check of local weather conditions, and a check of possible sources of radiation in the area. If this effort by the TWG required a substantial period of time, the TWG was expected to alert local officials about the situation and to keep them abreast of explanatory efforts.

CM's were instructed to notify the TWG in the event that the equipment was not operating properly. The TWG representative, in turn, either corrected the situation himself or notified either EG&G, Idaho or the Environmental Protection Agency both of whom had responsibility for maintenance of the equipment.

### III. TRAINING

#### Content and Schedule

The course consisted of eleven sessions scheduled over a three-week period as identified in Table 2. The course schedule was determined by the immediate perceived need for the program as identified by the communities involved and the availability of staff and facilities. Ten of the sessions were conducted at the Penn State Capitol Campus (about 4 miles from TMI), and lasted approximately 3 hours each. Each 3 hour session was divided into two parts separated by a half hour coffee break. One session involved a field trip to the Penn State Breazeale Nuclear Reactor operated by the University at the University Park campus. This session lasted approximately 6 hours. In addition to lectures, the course included four laboratory exercises, two supervised monitoring experiences, and numerous classroom demonstrations; a course outline is provided in Appendix B.

During the first lecture, the program was introduced by a DER representative. A survey was also administered to determine educational background and to measure the participants perceptions about their safety and about nuclear energy. The questionnaire and results are discussed in detail in Section VI, Results.

Topics covered for the first session included basic nuclear terms and definitions, e.g., definition of proton, neutron, electron. The basic structure of the atom and nucleus were also discussed as were several basic nuclear reactions. The instructor defined radioactivity, the curie, and half-life. This session also described common natural sources of radioactivity. The instructor concluded with a demonstration which measured radiation levels from a number of radioactive items with which people come in contact each day. Handouts covering the lecture material were provided for this lecture and each subsequent one. Copies of the handouts are provided in Appendix B.

The second session covered the way in which radiation interacts with matter and how ionizing radiation is detected. The session also prepared participants for the Geiger Mueller Counting laboratory held during the third session. Topics covered during the second session included definition of an ion and ion pair, discussion of relative ionizing power of  $\alpha$ ,  $\beta$ , and  $\gamma$  radiation, and their relative penetrating power. A series of demonstrations

Table 2

## Instructional Schedule for Citizen Monitoring Program

Monday March 31	Tuesday April 1	Wednesday April 2	Thursday April 3	Friday April 4	Saturday April 5	Sunday April 6
		4:30 p.m. to 9:30 p.m.  Introduction, Basic Terminology				
April 7	April 8	April 9	April 10	April 11	April 12	April 13
6:30 p.m. to 9:30 p.m.  Interaction of Radiation with Matter & Methods of Radiation Detection	6:30 p.m. to 9:30 p.m.  Radiation Counting Vari- ables & G.M. Counting Experiment	6:30 p.m. to 9:30 p.m.  Radiation Protection Units & Health Physics	6:30 p.m. to 9:30 p.m.  Radiation Inter- action with Bio- logical Systems and Radiation Counting Statis- tics Laboratory			10 a.m. to 4 p.m. (at PSU Reactor)  Equipment Familiarization & Argon-41 Monitoring
April 14	April 15	April 16	April 17	April 18	April 19	April 20
6:30 p.m. to 9:30 p.m.  Citizen Radiation Moni- toring Program	6:30 p.m. to 9:30 p.m.  Supervised Area Monitoring	6:30 p.m. to 9:30 p.m.  Supervised Area Monitoring & TMI Accident Cleanup		6:30 p.m. to 9:30 p.m.  Final Exam and Discussion of Community Radiation Moni- toring Results		
	April 22					
	6:30 p.m. to 9:30 p.m.  Meteorology Considerations Assignment. of Monitoring Krypton Disposal Techniques					

were conducted to illustrate these points. These principles and definitions were then applied to the operation of gas filled detectors. A gas filled detector was defined and its operation described. The ionization and Geiger Mueller (GM) regions were defined and their differences noted. Demonstrations of the radiation detection equipment which the citizens would later use for the monitoring program were made.

The third session involved a lecture on the fundamentals of radiation counting statistics and the first laboratory exercise. During the lecture, the instructor introduced the concept of the statistical nature of radioactivity and the concept of a distribution function. The instructor then discussed how one could estimate the mean and standard deviation for such a distribution from experimental data.

The second half of this session was devoted to a laboratory experiment in which students used the HP-260 GM probe and Ludlum ratemeter to measure  $\alpha$ ,  $\beta$ ,  $\gamma$  radiation from three sources  $\text{Po}^{210}$ ,  $\text{Sr}^{90}\text{-Y}^{90}$ , and  $\text{Co}^{60}$  respectively. The effects of various absorbers on count rate for these sources was observed as was the effect of distance on count rate. Participants were asked to record their observations and answer a series of questions which tested their understanding of what they were doing and related it to the earlier lectures. The laboratory procedure is provided in Appendix B.

The fourth session introduced the commonly used radiation units such as the roentgen, rad, and rem. The lectures discussed the relationship between radiation dose and energy deposited in tissue. In addition, the concept of quality factor was described as was the relative amounts of dose due to  $\alpha$ ,  $\beta$ , and  $\gamma$  radiation. The radiation dose from natural sources such as cosmic rays, terrestrial  $\gamma$  rays,  $^{40}\text{K}$  and  $^{14}\text{C}$  was also discussed.

The next session, described the biological effects of radiation. Topics discussed included the damage sites within cells, the relative sensitivities of different organisms, and definition of acute and chronic doses and associated health effects. The concept of risk was also discussed in the lecture. A comparison of risks associated with radiation and other biological and chemical hazards was made. Of all the lectures, the topics discussed in this one created the most controversy and uneasiness among the students. Because of this, the instructors devoted additional time to this topic at a subsequent class.

Also included in this session was the second laboratory exercise. The laboratory work investigated the statistical nature of radiation. Students were asked to determine the average background count rate and to estimate the mean and standard deviation. The process was repeated for several radioactive sources. The laboratory procedure is provided in Appendix B.

The sixth class was held at the Pennsylvania State University's Breazeale Nuclear Reactor. The purpose of this session was to allow the students additional experience with their equipment and to allow them to see how it responded to various radiation fields. In addition, for many of the students this was the first time they had seen an operating reactor.

The laboratory work involved the measurement of radiation fields in the reactor building at various reactor power levels. The principle radiation source was airborne  $^{41}\text{Ar}$  produced by the reactor. Students were asked to record background levels prior to startup and then record radiation levels at various power levels up to and including full power (1 MW). Both the LSI and Ludlum systems were used during this exercise.

Students also participated in the calibration of the Ludlum systems. This portion of the laboratory exercise involved exposing the detectors to  $^{85}\text{Kr}$  at a concentration of approximately  $2.1 \times 10^{-5} \mu\text{Ci/cc}$ . Students were asked to observe their instruments prior to and during exposure to the  $^{85}\text{Kr}$ . The testroom used for the calibration effort was the same used to initially test the various detectors proposed for this Program and is described in Appendix A of this report.

The next session, session number seven, was a review of the biological effects material covered earlier. This was accomplished through the use of a slide show developed by the National Society of Professional Engineers. The slides and transcript are included in Appendix B.

In addition, one of the staff reviewed the previous lecture's major points and answered student questions.

During this session, students were given a scheduled ten question quiz. The quiz covered basic material discussed in the preceding lectures. A copy of the quiz is included in Appendix B. The students were asked to exchange papers and grade each others quiz. A count of the number wrong was made. No quizzes were retained by the instructor nor were the grades recorded. The average grade was two wrong. This exercise demonstrated to the participants that they were learning the material and helped build up their confidence.



The last part of the class was devoted to a review and discussion of what the Citizen Radiation Monitoring Program was and how it would operate. Students were asked to comment on the program organization and operation. This provided an opportunity to acquaint the students with the proposed procedures and to solicit their reactions, suggestions, and modifications, thereby including them in the set-up of the Program.

The eighth class was a combination lecture laboratory exercise. The lecture described in detail the monitoring procedures to be followed by the citizens during the monitoring effort. The instructor reviewed the function of each control on the two radiation detection system and described how to read the strip chart printout. Sample strip charts were discussed in detail. The form to be used in recording the data was also described along with how to interpret the information. The procedures, sample strip charts, and monitoring form are included in Appendix C.

The laboratory exercise involved the measurement of background radiation using both the LSI and Ludlum systems. A series of abnormal readings were introduced using small sources. This allowed the students to again observe the response of their instruments to radiation. The students were then asked to individually read and interpret the strip charts. Their findings were reviewed for accuracy and critiqued by the staff.

The TMI-2 accident was discussed during session number nine. The presentation was given by Mr. Bill Dornsife, a nuclear engineer with DER. He recounted both his personal observations during the accident and the accident scenerio. Considerable discussion ensued throughout this lecture. A copy of this lecture appears in Appendix B.

The last half of the session was devoted to another monitoring exercise similar to the previous session.

The tenth session consisted of a final exam. The exam was divided into two parts, a theory and practical section. A sample exam is provided in Appendix B. Of the 40 students who took the exam, 36 passed. Passing score was 65. A makeup exam was subsequently scheduled for those who failed or did not take the exam. The second half of the class was devoted to a critique by the students of the course. The comments are discussed in the Results section of the report. Also, at this time a second survey was conducted to measure the participant's perception about their safety and about nuclear energy. The result of this and the earlier survey are discussed in Section VI of this report.

The last session of the course was devoted to a review of the exam, a discussion of the proposed  $^{85}\text{Kr}$  disposal methods, and plume dispersal. The discussion of plume dispersal included definition of the various atmospheric conditions and rating of each regards venting. The  $^{85}\text{Kr}$  disposal lecture stressed the hazards associated with each method proposed by the NRC and evaluated in their environmental assessment report<sup>3</sup> and the probability of success and of accidents. The abnormal reading that occurred at the EPA Middletown monitoring station the previous day was discussed. Upon completion of the lecture, plans to begin monitoring were announced as were plans to hold a follow-up class to review the monitoring effort.

The follow-up class meeting was held approximately two weeks after the previous class. During this class, the citizens were asked to provide comments on their experiences. As a result of these comments, changes were made to the monitoring procedures. The revised procedures are included in Appendix C.

Also discussed as part of this session was the disposal of radioactive waste. The discussion mainly involved a description of current low level waste disposal methods.

A graduation ceremony was held on May 12, 1980. The ceremony included Secretary Jones of DER as its principle speaker. A reception followed the exercise.

### Building Credibility

The communication of complex scientific concepts is difficult even in an environment devoid of emotionalism and distrust. In situations where such elements are present the task becomes almost impossible if conventional teaching techniques are the sole devices used. In such an environment an effort must be made to develop credibility with the students and to manage the expression of emotion constructively.

The effort to build credibility included careful attempts to document the "factual" material presented. Frequent references to recognized journals and publications were included in handouts with each lecture. An example is the use of the Radiological Health Handbook<sup>7</sup> published by HEW as a source for radioisotope information. In addition, every effort was made to minimize expression of personal opinion by the instructors during classroom discussion. Instructors assumed a neutral stance regarding nuclear power as a source of energy. No attempts were made to persuade students to change their attitude regarding nuclear energy.

The course design was based on a program, Nuclear Concepts and Energy Resources Institute, used successfully by Penn State faculty in the past. In addition to ideas on course content, the Nuclear Concepts Program found that time for informal interaction greatly enhanced rapport between students and professors. Toward this end, a half hour "coffee break" between the first and second half of each session was purposely built into the training program. This break allowed staff and students to interact informally with each other, to ask questions, or to express personal feelings and concerns. As a result, both students and staff developed a rapport conducive to learning.

Creation of a classroom environment was a primary emphasis of the training. This established credibility by identifying the course subjects as highly technical in nature. The participants would therefore be required to master factual, scientific material rather than to simply express opinions. The very first lecture purposely stressed technical material to establish this point. While such an approach did discourage some participants initially, they were encouraged to continue by the staff, who pointed out that an initial technical understanding of the material was needed before practical applications could be described. As the course developed, more and more practical applications were included.

Credibility was further enhanced by choice of instructors and class schedule. In particular, handling of controversial topics was carefully planned. Instructors were chosen who were estimated to be (1) special experts on the topic, (2) unbiased in their presentations, and (3) able to develop rapport with the students. Furthermore, three local science teachers trained in nuclear science provided necessary assistance during the laboratory exercises. Also, because teachers are generally respected members of the community, it was hoped their presence would add credibility to the Program. In addition, the class schedule was arranged such that the more controversial topics came later in the course. This was done so that a certain amount of credibility could be developed prior to discussion of those topics the participants felt strongly about. One topic was particularly difficult. During a presentation on the biological effects of radiation the participants became extremely uneasy. This topic was of major concern to them. The problem centered around the concept of relative risk which was difficult for the students to accept. This then led to questioning of the other material presented by the instructor. As a result a certain amount of credibility with the group may have been lost.

Because controversial topics understandably heightened the participants' anxiety and exposed a number of misconceptions about radiation and its effects, the staff created a number of opportunities for informal interaction between themselves and the students. Through these interactions the staff sought to increase the students' confidence in the ability and motivation of the staff to fairly represent the information. The first opportunity occurred during the field trip to the Breazeale Nuclear Reactor at Penn State's University Park campus. Additionally the staff made themselves available at optional social hours for general discussion and listening to participants' concerns. Such sessions tended to improve rapport with the participants, to reduce anxiety, and to increase the participants' confidence in the Program.

Another method used to build rapport was to provide candid and direct answers to all questions. The staff made every attempt to be responsive to the questions and the concerns of the students. These included providing students with additional reading material on subjects of concern to them, arranging for extra help if needed, and placing students in contact with those staff who could best answer their questions.

In summary, attempts were made to build credibility through the use of a variety of methods. These included presentations of the material in as factual a manner without opinions on advocacy, adopting various rapport-building processes such as coffee breaks, and attempts to be responsive to the concerns and questions of the participants. The success of the approaches adopted and the participants high motivation may be seen by the low (4%) dropout rate. The results of the two attitude surveys also showed that the participants continued to view the Program as credible. (See Results, Section VI.)

#### Measuring Progress

To determine the educational progress of the students, three methods were employed. These methods were written tests, discussion with and observation of students during laboratory exercises, and discussion with students during breaks.

Two written tests were administered during the course of the program. The ten question quiz on theoretical material given during the seventh

session appears in Appendix B. This quiz provided written confirmation to both students and instructors of satisfactory progress at the mid point of the course.

The second exam was a comprehensive final exam. It tested the students' understanding of both the theoretical and practical aspects of the course. The test consisted of thirty-three questions covering radiation, radiation units, biological effects, monitoring procedures, and monitoring instruments. A copy of the exam and the results are provided in Appendix B. This exam provided written confirmation that the participants had satisfactorily mastered the course work.

Another less formal but equally important method of evaluating progress was the discussions with and observation of students during the laboratory work. In the various laboratories it was possible to work with students individually and assess their understanding of what they were doing and why. Through such first hand one-on-one experiences, the staff was able to determine problem areas and take appropriate action. This method of ongoing evaluation of student progress was continued throughout the course.

Similar discussions were also conducted with students during the break periods. Here students were approached and asked what material they found troublesome or asked specific questions on material covered to date. Again, this allowed ongoing evaluation of progress to be performed.

### III. MONITORING

#### Introduction

This section describes the actual monitoring effort. In particular, the start-up of the monitoring is described along with the evaluations performed and the "debugging" effort. In the last section, the staffing responsibility and protocol are discussed.

#### Start-up

With the completion of the formal training program on April 22, 1980, the program entered the operational phase. The beginning of this phase involved setting up the LSI and Ludlum systems in each of the twelve communities. To accomplish this, two TWG members arranged to visit the sites and set up the equipment. The monitors for the community were asked to be present along with the community officials who had appointed them. The monitors were briefed on and given a final checkout on the equipment. Equipment installation was essentially completed by April 30, 1980.

Once the equipment was installed, the monitors began several days of practice monitoring. This involved reading the LSI and Ludlum strip charts on a daily basis and recording their findings on the Community Monitoring Report (see Appendix D for sample report). During the first few days of this period, no pickups of the data were made pending finalization of the DER circuit rider procedure. Data pickup began on May 5, 1980.

On May 7, a follow-up class meeting was held to critique the progress of the monitoring effort. As a result of that class discussion, a revised procedure (Rev 2 dated May 12, 1980) was issued (see Appendix C). From May 7, 1980, to May 19, 1980, monitoring continued but without formal publication of the results. During this period the TWG responded to various equipment problems and complaints. DER collected the data, and summarized it. Copies of the summaries were provided to the participants' communities (see Appendix D for sample).

On May 20, 1980, the monitoring program became fully operational. On May 23, the summary data was formally released to the press, other state agencies, federal agencies, and anyone requesting the information.

#### Debugging

Throughout the start-up phase, problems were encountered with procedures and equipment. As a result, the program underwent an extensive debugging phase. The more significant problems and their solutions are described in this section.

The first problems encountered concerned the procedures. An initial set of procedures had been developed and issued during the formal training program. These procedures were used during the various laboratory exercises where the students performed supervised monitoring. It quickly became apparent that the procedures could be improved. For example, no troubleshooting process was provided, several minor errors existed. As a result, a revised procedure (Rev 1 dated April 22, 1980) was issued.

Rev 1 was used up until the follow-up class meeting on May 7. At that meeting a number of procedural problems were discussed, and an agreement was reached to resolve them. For example, DER personnel found it too time consuming to copy all strip charts so that the originals could be returned to the communities. As a result, it was agreed that DER would retain the charts. The charts would be available for review and copying by the communities if they requested them.

Another problem concerned transmittal of the data. The monitors and circuit riders requested the procedure be revised to allow placement of the data into the LSI suitcase in lieu of the Ludlum box. The Ludlum box was too difficult to open. Since DER provided the circuit rider and performed the data reduction and compilation, the circuit was revised to provide for drop off and pick up of the data at DER headquarters in the Fulton Building.

The procedure was also revised to require the monitors to check the chart recorders for sufficient paper. This was the first of many problems encountered with these recorders.

The strip chart recorders were the single most significant equipment problem encountered in the program. A total of 23 days worth of data was lost (see Table 3) because of the recorders. The recorders used were Rustrak recorders. They provided a continuous permanent record of the radiation levels recorded by the LSI and Ludlum detectors. Each LSI and Ludlum was equipped with its own recorder. For the LSI, the recorder provides the only readout. The single most common problem was jamming of the chart paper in the recorder. This occurred when the sprocket holes in the paper were torn, the paper cocked during tear off, or the paper was improperly installed during replacement. In addition, frequent problems were encountered with hangup of the indicator pen. These problems were never completely resolved. Eventually, the monitors were trained to replace the chart papers in the event a jam occurred or a new roll of strip chart paper was required. They were also told to tap the recorders if the indicators hung up.

Another equipment problem found during the debugging phase concerned the LSI's. Sixteen days of monitoring were lost because of problems with the LSI's. These instruments were originally designed and built about twelve years ago by Learsiegler for EPA's use at their Nevada test site. These instruments were provided by EPA to the program under a cooperative agreement between DOE/EG&G/EPA. The equipment as originally designed was expected to be water tight. Due to their age and lack of maintenance, the LSI's were susceptible to malfunction during humid or rainy weather.

The sensitivity to humidity may be attributed to the fact that the equipment was originally designed for use in an arid environment. The

Table 3  
Operating and Equipment Problems<sup>1</sup>

Township	#days no report due to		Type of Equipment Problem			# Errors
	Citizen Failure	Equipment Failure	LSI	Ludlum	Rustrak Recorders	
East Manchester	3	7	4	2	1	0
Newberry	2	4				1 no signature
Fairview	0	6	4	0	2	2 incorrect decimals 1 date missing 1 switched values
Conoy	7	7	1	2	4	4 incorrect readings 1 wrong date 1 no signature
Goldsboro	0	6	6	1	5	0
Yorkhaven	0	5	2	0	3	1 no signature
Lower Swatara	8	1	0	0	1	1 incorrect reading
Middletown	1	2	1	1	0	0
Royalton	0	4	1	1	2	1 incorrect reading 1 missing data
Londonderry	1	4	2	1	1	2 incorrect decimals
West Donegal	2	3	0	0	3	5 incorrect reading 2 no signature
Elizabethtown	5	4	1	2	1	7 incorrect reading 1 wrong data
TOTALS	29	53	16	10	23	32

<sup>1</sup>Covering a 42-day period 5-20-80 to 7-3-80



malfunctions included hang up of the recorder movement, failure of the detector, and a failure mode which produced excessively high readings. The monitors were instructed to be aware of these problems, to notify the TWG, and to request replacement and service when malfunctions occurred.

Two minor problems were encountered with the Ludlum detector system. The first concerned the metal box that was designed to contain the system. Insufficient clearance was allowed around the instruments. As a result, the locating tabs on the cover could strike the "ON-OFF" switch on the Ludlum ratemeter thereby shutting the system down. As this was a frequent occurrence, the monitors were told to inspect the instrument once the cover was in place to ensure the ratemeter was on. The lack of clearance also caused some minor cable chafing.

The second problem involved the interconnection between the Ludlum ratemeter and the Rustrak recorder. The interconnection is accomplished using a phone jack and Jones plug. Apparently vibration would cause one or both to loosen. The result would be a zero reading on the recorder. A tap on the side of the Ludlum case would usually cure the problem. The monitors were instructed to check for this condition and report its occurrence.

#### Periodic Evaluations

Throughout the monitoring phase, the TWG met to review problems and take corrective action. In addition DER performed daily reviews of the monitoring results checking for accuracy and consistency. Again, if any problems were identified the appropriate monitors were contacted. In general, these evaluations revealed few errors on the part of the monitors or staff. A total of 32 errors were made by the twelve communities. Twenty-five of those were incorrect readings but of a minor nature. The remaining seven errors involved failures in properly completing the monitoring form. In other instances, the equipment was found deficient. These deficiencies have already been described.

#### Staffing Responsibilities

The staff of the monitoring program consisted of DER, PSU, EG&G, Idaho and EPA personnel and the community monitors. During the monitoring phase, each agency assumed part of the responsibility for overseeing operation of the program.

EPA assumed responsibility for periodic checkout of the LSI and Ludlum systems. This was accomplished by EPA personnel assigned to service the EPA monitoring equipment. The EPA personnel would use a check source to see if the equipment was operating properly. They would also check for sufficient strip chart paper. The EPA checks were made on a weekly basis.

DER, PSU, EG&G, and EPA personnel jointly assumed responsibility for troubleshooting during the start-up phase of the program. Each group provided individuals who would be assigned the responsibility of responding to problems reported by the monitors. A weekly duty roster was developed to provide for these assignments. On occasion, failure to communicate the assignments to the monitors led to some confusion on their part.

At the completion of the start-up phase, DER assumed responsibility for responding to reported problems. PSU, EG&G, and EPA provided back-up and consultation if requested by DER.

#### V. COMMUNITY ASSUMPTION OF RESPONSIBILITY

In Section II of this report, mechanisms for community input into the program design were described. During the time from March through May the citizens' contribution to the design and operation of the program increased. Once individuals were nominated from each community, the classroom became the primary vehicle for community input to the Program's design. During the training program, dialogue between the instructors and the citizens influenced the design of the data collection and dissemination. Basic procedures drafted by the TWG were refined and tailored by the citizens to meet their individual community needs. This give-and-take between the TWG and the monitors served three purposes: first, it created rapport between the TWG and citizens; second, it provided necessary input to improve the program's operation; and third, it began the process of transferring some of the technical and management responsibility for the Program to the communities involved.

Community officials were kept abreast of the Program's progress and were asked for specific input to shape its direction periodically over the next few months. At one of these meetings, the community leaders reviewed the training program and a detailed plan for data collection and dissemination. Within technical guidelines provided by the TWG, each community was asked to determine a specific site for its monitoring equipment and a date for its installation.

During the preliminary operating phase the primary citizen input came from the monitors themselves who had the firsthand experience with problems in the system's operation. Once installation of all the monitors was completed, the class was expressly convened to critically review the procedures. The citizens provided a number of suggestions which led to decisions in the operating procedures.

By June when the Nuclear Regulatory Commission announced its decision permitting Met Ed to vent radioactive gas from the reactor building, the monitors had had one month of official monitoring experience. At a meeting convened by the TWG, the monitors and their local townships officials assumed major responsibility for operating the Program. Each community drew up and presented a plan for monitoring during and after the venting period. This plan included a schedule for making measurements and for publishing the results and identification of any assistance required from the TWG to carry out the plans. Some townships decided to make readings more frequently during the venting. One requested a second monitoring site be established at the opposite end of their township to quell fears of residents in that area. Others agreed to exchange and compare their results. Some made tentative plans to reduce the frequency of monitoring once the venting had subsided.

## VI. RESULTS

### Monitoring Results

The official monitoring effort commenced on May 23, 1980, and continued through and beyond the purging of the TMI-2 containment. Practice monitoring preceded the start of the official effort by several weeks. Each of the twelve communities operated a monitoring station consisting of the LSI and Ludlum systems described earlier. Each system output was recorded on a strip chart.

At the time venting of the TMI-2 containment began, June 28, 1980, about nine weeks of operating experience and background data had been accumulated. Starting on May 23, 1980, these data were distributed to the news media, other federal and state agencies, the utility and public at large. The pre-venting data was used to establish baseline gamma and beta radiation levels at each of the monitoring sites. Table 4 contains a

summary of this data for the period May 23, 1980 through June 27, 1980, the start of venting. Listed for each station is the average gamma and beta dose rates recorded for this period. The gamma dose rate is an arithmetic average of the daily averages reported by the monitors. The beta dose rate corresponds to the minimum detectable beta levels that could be measured by the Ludlum GM system. (The actual readings were in counts per minute and were converted to mrem/hr using the calibration procedure described in Appendix A.) This data provided an estimate of the background levels typical of the area. Typical recorder traces from which the data was obtained are contained in Appendix C. The summary reports distributed to the media, and other groups are included in Appendix D.

During the pre-venting period, it was also observed that data from the Ludlum GM system displayed increased apparent radiation detection rates during the passage of electrical storms.<sup>8,9</sup> It is not clear at this time, whether this phenomenon is related to instrument electronics, or to a temporary rearrangement of the radiation environment during these storms or perhaps both.

The purging of the TMI-2 containment began June 28 and continued through July 11, 1980, a total of 14 days. The resulting krypton-85 plume was detected at least once at 10 of the twelve stations during the venting period. The station measuring the highest beta dose rate (0.0399 mrem/hr), Londonderry, located 1 mi in a northeasterly direction from TMI. The station measuring the highest accumulated beta exposure (0.105 mrem) during the venting was also the station which had the highest beta exposure in any one day (0.057 mrem). This station was located in Londonderry, approximately one mile northeast of TMI.

The data for the purge period are summarized in Table 5. The data generated by the Program is generally consistent with data produced by other organizations such as EPA who used other measurement techniques.

Summary of Community  
Monitoring Data  
Pre-Purge  
(23 May - 27 June 1980)

	Average Dose Rate (mrem/hr)	
	<u>Gamma</u>	<u>Beta</u>
Fairview	0.0094	0.005
Newberry	0.0080	0.005
Goldsboro	0.0136	0.005
York Haven	--	0.005
E. Manchester	0.0143	0.005
Lower Swatara	0.0071	0.005
Middletown	0.0095	0.005
Royalton	0.0159	0.005
Londonderry	--	0.005
Conoy	0.0129	0.005
W. Donegal	0.0102	0.005
Elizabethtown	0.0080	0.005

Table 4

Summary of Community  
Monitoring Data  
Purge  
(28 June - 11 July 1980)

	Average Dose Rate (mrem/hr)		Maximum Beta Skin Dose Rate Due to <sup>85</sup> Kr (mrem/hr)	Total Beta Skin Dose Due to <sup>85</sup> Kr (mrem)
	<u>Gamma</u>	<u>Beta</u>		
Fairview	0.0097	.005	—————	ND
Newberry	0.0079	.005	0.0057	0.003
Goldsboro	0.0144	.005	0.0114	0.004
York Haven	—————	.005	0.0342	0.041
E. Manchester	0.0126	.005	—————	ND
Lower Swatara	0.0077	.005	—————	0.006
Middletown	0.0099	.005	0.0171	0.030
Royalton	0.0168	.0053	0.0171	0.087
Londonderry	—————	.0053	0.0399	0.105
Conoy	0.0126	.005	0.0086	0.036
W. Donegal	0.0150	.005	0.0171	0.011
Elizabethtown	0.0081	.005	0.0057	0.015

Table 5

## Survey Results

An effort was made during the Program to assess the monitors perceptions about their own safety and about the credibility of the information they received. A survey was administered on the first day of class ( $t_1$ ) and again on the last day ( $t_2$ ) to see if there were any significant differences in the citizens' attitudes over this time.

The following sample question illustrates the format: "I feel well-informed about the progress of the clean-up activities at TMI." Responses were recorded on a five point Likert scale varying from strongly disagree to strongly agree. Mean responses values were compared using a t-test. (See Table 6 for a list of questions and mean response values).

Generally, the results demonstrate improvements in how informed and how safe the citizen monitors felt. While the mean values of the responses to these questions only indicated they had neutral to slightly positive feelings about safety, this did represent a significant change for three questions. The responses indicated that the monitors felt better-equipped to judge their own safety at the end of the course than they did when it began.

The citizens were also asked to rate (on a five-point scale) the quality of the information they received from eleven organizations. The list of organizations included the NRC, Met Ed, the Governor's office, and local officials of the agencies represented in the TWG. The citizens rated the quality of information from Met Ed and the NRC as poor (3.6 and 3.5, respectively) and that from The Pennsylvania State University as good (1.8) with ratings of other agencies falling somewhere in between. (See Table 7). No significant changes in these ratings were observed from the beginning ( $t_1$ ) to the end of the course ( $t_2$ ) with the exception of those for EPA which improved from 2.7 to 2.2. This may be explained by the fact that EPA's efforts became more visible to the citizens during the Program, since EPA provided and maintained some of their monitoring equipment.

On the second survey an additional ten questions were asked specifically about the citizen monitoring program and the course itself. Response choices again ranged from strongly agree to strongly disagree. Table 8 presents the questions and mean response values.

Table 6. Attitude Survey Results

.....1:.....2:.....3:.....4:.....5:..

Strongly Disagree      Disagree      Neutral      Agree      Strongly Agree

Attitude Items	t <sub>1</sub>		t <sub>2</sub>		p <sup>1</sup>
	Mean	S.D.	Mean	S.D.	
1. My community is a safe place in which to live.	3.3	1.1	3.5	1.0	n.s.
2. I feel well-informed about the progress of the clean-up activities at Three Mile Island.	2.5	1.3	2.7	1.2	n.s.
3. I receive a minimum exposure to radiation every day which does not pose any hazard to my health.	3.6	1.0	3.7	1.0	n.s.
4. I have access to sufficient information from existing public and private sources to make a judgment about my safety with respect to radiation.	2.9	1.3	3.4	1.0	.01
5. Metropolitan Edison should proceed with the clean-up activities at Three Mile Island as quickly as possible, even if it means venting the Krypton gas to the atmosphere.	3.2	1.6	3.5	1.4	n.s.
6. I feel well-informed about what to do in case of an emergency.	2.9	1.3	3.3	1.2	n.s.
7. Radiation levels in my community are currently above safe levels.	2.6	.9	2.2	1.1	.02
8. The Nuclear Regulatory Commission (NRC) should not permit Metropolitan Edison to re-open reactor #1.	3.1	1.4	2.7	1.6	n.s.
9. I currently can get accurate information about radiation levels in my community.	2.5	1.2	2.9	1.2	.03
10. Most of my friends and neighbors in my community are well-informed about radiation and its effects.	1.9	.8	1.7	.8	n.s.

<sup>1</sup> Significance values for 2-tailed t-test



Table / Credibility of Information Sources

Use the scale below to rate the quality of the information that is available from each of the following sources.

.....:1:.....:2:.....:3:.....:4:.....:5:.....  
 Excellent.                      Good. I                      Sometimes Good                      Poor.                      Bad. I  
 I trust it com-                      trust it most                      Sometimes Bad.                      I don't trust                      never trust  
 pletely.                      of the time                      I trust it 50%                      it much.                      it.

Information Sources	t <sub>1</sub>		t <sub>2</sub>		p <sup>1</sup>
	Mean	S.D.	Mean	S.D.	
Pennsylvania State University (PSU)	2.0	.8	1.8	.5	n.s.
Pennsylvania Dept. of Environmental Resources (DER)	2.6	.8	2.2	1.0	n.s.
Environmental Protection Agency (EPA)	2.7	.7	2.2	.8	.05
Township Officials	2.3	1.1	2.4	.9	n.s.
County Emergency Preparedness Agency	2.6	1.2	2.7	1.0	n.s.
Department of Energy (DOE)	3.0	.7	2.8	1.1	n.s.
Pennsylvania Emergency Preparedness Agency (PEMA)	2.5	1.1	2.9	.9	n.s.
County Officials	2.8	1.0	3.0	1.0	n.s.
Gov. Thornburgh's Office	3.0	1.2	3.3	.7	n.s.
Nuclear Regulatory Commission (NRC)	3.3	1.2	3.5	1.2	n.s.
Metropolitan Edison	3.9	1.2	3.6	1.3	n.s.

<sup>1</sup> Significance values for 2-tailed t-test

Table 8 Course Evaluation

Please use the scale below to answer the next 10 questions.

::.....:1:.....:2:.....:3:.....:4:.....:5:.....:

Strongly Disagree      Disagree      Neutral      Agree      Strongly Agree

	Mean	S.D.
I did not learn anything in this course that I didn't already know.	1.5	.8
I feel better equipped to explain radiation and its affects to my neighbors then I did before the course began.	4.1	.9
This course provided far too much information.	2.3	1.0
I am well prepared to begin my job as a citizen radiation monitor in my community.	3.7	.8
Most of the material covered in this course was not relevant.	2.1	1.0
I received accurate information from the course instructors.	4.2	.6
This program will provide needed information to people in my community.	4.1	.6
My feelings about being a citizen radiation monitor are generally positive.	4.1	.6
I feel less secure now living near TMI then before I began the course.	2.2	1.1
I have been brainwashed in this course.	1.8	.83

Responses to items 1, 2, 5 and 7 reveal that the citizens believe they received needed information from the course. Responses to items 6 and 10 also suggest that they trusted those who provided the information. Moreover, the responses indicate that the citizens did not feel that the course influenced them to either accept or reject nuclear power. This was important since the course instructors took great care to insure that the instruction was not construed as favorable propaganda for nuclear power or for or against Met Ed in particular. With regard to serving as monitors, the citizens indicated they felt positively about the task and moderately prepared for it. Their primary reservations about their preparation stemmed from wanting more time to practice with the equipment.

The survey results affirm that the Program was at least moderately successful in meeting its purpose, that of providing an accurate and credible source of information about radiation levels to citizens around TMI.

#### Citizens' Comments

In addition to the structured questions about the course, on two occasions the citizens were asked to answer open-ended questions about the course and the instructors. The questions were:

What did you like best about the course?

What did you like least about the course?

Are there other comments you wish to make about the course?

What suggestions do you have for improving this course?

A summary of all the individual responses to these questions appears in Appendix E. A number of themes can be identified from the comments which represent the opinions of many of the participants.

Regarding the quality of the information, many participants indicated that the course responded to the communities' need for information and that the material was well presented overall. A number of people indicated that some concepts were too technical and went over their heads. Others complimented the instructor's success at relating the material in layman's terms.

The trip to the Penn State Nuclear Reactor was frequently cited as something they liked the best. Operating the monitoring equipment in the laboratory was also well received.

Many citizens commented about the fair and objective presentation of the material.

"It was objective rather than opinionated in its presentation."

"Being able to feel I'll be an asset to my community in reading meters to warn of troubles. As a listener I learned how the pro-nuclears feel."

"The opportunity to see a different scope of the situation."

"The instructors were impartial and did their best to take scientific data and bring it to the layman. I felt they did not try and influence anyone's opinion whether they were anti or pro nuke....I can live with the truth, but lies do create fear and strong distrust."

Only two of the forty-six indicated they felt aspects of the course favored the pro-nuclear point of view. One indicated the material was "biased to protect the side of the nuclear industry." Another individual wrote,

"The filmstrip on the low contribution nuclear power plant made to the background radiation exposure was a very one-sided presentation. Tomorrow night a special is going to be on concerning how uranium mining is killing people, I'm sure I'll be more knowledgeable on this safe technology after this show.

There were some positive points to this course. I felt all the people involved with the teaching of the course made 100% effort to answer questions and to be as factual as possible. There seemed to be a genuine interest in making this course a success and at making people as knowledgeable as possible."

Many citizens acknowledged the patience and helpful attitudes of the course instructors and attributed their own positive response to the course to these characteristics. By in large the instructors were perceived as honest experts and as real people.

The primary drawback identified by the monitors was the condensed format of the course. Many indicated they would have liked more time to review, study and absorb the material than the schedule of consecutive evenings permitted. A few pointed out that they would have benefited from a more detailed explanation of what was involved in the Citizen Monitoring Program early in the course. They wanted clarity on what it meant to participate as a citizen monitor, how the program would operate and the type of monitoring equipment which was to be used. One citizen commented:

"There appeared to be day to day planning as far as the monitoring program itself. For example, no clear cut definition was given the first night as to the type of equipment or exactly what individuals would be required to do at the end of the session."

A few felt that the course provided too much background information, but most seemed pleased to receive all that the course offered. When queried about those topics about which they needed additional information to do their job as a citizen monitor, TMI-2 clean-up efforts were most frequently identified. The topics about which more information was requested were:

- Nature and sources of radioactivity
- Interaction of radiation with matter
- Methods of radiation detection
- Radiation protection units
- Biological effects of radiation
- TMI-2 Accident
- TMI-2 Clean-up efforts
- Operating procedures for the Ludlum and/or LSI
- Interpretation of the strip chart results
- What to do when I begin monitoring in my community
- Overall operation of the Citizen Monitoring Program

Those responses and other comments provided by the citizens suggest that their appetite for information about TMI and nuclear energy generally was barely whetted by this course. A number asked for follow-up courses. Others expressed the desire for similar course offerings for a wider segment of the community. A few of these comments are characteristic:

"This course was well put together and presented given what was probably short notice. Some thought should be given to an on-going (monthly or so) course covering various topics as well as reviewing material already presented to keep it fresh."

"Worthwhile, wish more people could take it. Feel this will be a good service to the community and wish it could extend to a ten mile radius."

"Most of this material presented to the general public in a proper way would definitely enlighten them, increase their confidence and improve the general sense of security."

## VII. CONCLUSIONS AND RECOMMENDATIONS

In the preceding sections of this report, the Citizen Monitoring Program design, operation and results are described. This section summarizes major conclusions about the program and offers recommendations for future programs of a similar nature.

### Conclusions

Based on interviews with local community leaders, the monitors themselves, and state and county officials, the Citizen Monitoring Program was successful in providing a source of credible information to the public at large. In fact, one official commented that the Program was one of the most significant activities that helped make people feel safe during the purge. A review of the data by EPA, DER, and GPU, revealed the monitoring results to be consistent with those obtained by these agencies.

The design was, in general, consistent with the above objective. Certain aspects of the design and operation of the Program were particularly important in achieving that objective. These included the following:

- ° The rapport building efforts during the training program were particularly important. As a result they should be explicitly considered in the design and development of future programs.
- ° The "debugging" phase provided valuable experience and time for resolution of emerging problems. Such a period should be built into any future program.
- ° The factual authoritative manner in which the Program was conducted provided it with a high degree of credibility among the participants. As a result future programs should be conducted in a similar manner. No attempt at advocacy should be made.
- ° The experience of the University Staff in the summer science teacher program provided valuable background for conducting the training portion of the Program. Those lacking in such experience will require additional preparation time.

### Recommendations

The experience of developing and operating a Citizen Radiation Monitoring Program for the first time has prompted some important lessons. These are put forward as action recommendations for future projects of a similar nature.

- ° The Program should encourage community input into and responsibility for the design and implementation. That is, local officials and citizens should participate in the initiation and planning of the Program as well as in its implementation. Such participation will increase the likelihood that the Program is responsive to community needs, promote community understanding of what the Program is trying to achieve, and facilitate eventual transfer of responsibility for the Program to the community once it is operational. Implementation of this recommendation involves efforts by the sponsors to build such participation into the Program design from the outset.
- ° Considerable reliability problems occurred with some of the instrumentation. To avoid these problems in future programs, a comprehensive environmental and reliability program should be undertaken to identify reliable instrumentation suitable for such programs.
- ° Among the participants in the Program there was a clear lack of understanding regarding the basics of radiation, radiation effects, and radiation detection. Insofar as the participants are representative of residents near a nuclear power plant, there appears to be a need for increased educational efforts in areas surrounding such facilities.
- ° Some difficulty was encountered regarding the specific role assignments of the organizations comprising the TWG. To minimize this problem in future programs, time and effort should be devoted to team development activities, with particular emphasis on clarification of roles and coordination mechanisms. Similar team development should be conducted with the monitoring team from each community to encourage a cooperative spirit and to insure that the monitoring work was distributed evenly among the participants.
- ° Because the media were already receiving reports from other government agencies and the utility, they were reluctant to report the results of the Monitoring Program. As a result, some news outlets did not report the program's findings. To alleviate this problem, the media should be better advised as to the significance of the effort. In addition, they should be invited to participate early in the design, development, and operation of such programs.

- ° In an effort to improve dissemination of the Program results, a training session should be included to instruct the monitors in how to handle inquiries from fellow citizens.
- ° In some cases, the lack of rapid availability of the data hindered the TWG's ability to diagnose trouble and respond to it. An effort should be made to develop an on-line remote monitoring capability. This would supplement the monitors' readings and provide for quick diagnosis of problems or abnormal readings should they occur.
- ° To reduce the burden on the volunteers during the training program, the training session should occur at the rate of no more than three times per week. In addition an attempt should be made to schedule them on an every other night basis.
- ° To resolve individuals' concerns about their ability to operate and read the instruments correctly, the practice monitoring should be made a portion of the formal training program. In addition, each citizen should be tested and checked out individually on operation of the monitoring equipment and on the reading of the tapes.
- ° To resolve some of the troubles encountered with the chart recorders and other instruments, the monitors should be instructed early in the program in how to change the chart paper and perform rudimentary maintenance.



#### REFERENCES

1. M. Rogovin, Three Mile Island a Report to the Commission and the Public, NTIS, January 1980.
2. J. G. Kemeny, Report of the President's Commission on the Accident at Three Mile Island, NTIS, October 31, 1979.
3. TMI Support Staff, Office of Nuclear Reactor Regulations, Environmental Assessment for Decontamination of the Three Mile Island Unit 2 Reactor Building Atmosphere, NUREG-0662, U.S. Nuclear Regulatory Commission, March, 1980.
4. W. W. Scranton, III. Chairman, Report of the Governor's Commission on Three Mile Island, Commonwealth of Pennsylvania, February 26, 1980.
5. Letters between J. L. Mowery, Lancaster County Commissioner and T. M. Gerusky, PA Dept. of Environmental Resources, October and November, 1979.
6. Transcript of the hearing.
7. Radiological Health Handbook, U.S. Department of Health, Education, and Welfare, January 1970.
8. M. A. Reilly, "The Measurement of Kr-85 by a Community Monitoring Program," Trans. of ANS, Vol. 35, November 1980.
9. M. A. Reilly, private communication.

Appendix A

Monitoring Equipment Test Report

EVALUATION OF RADIATION MONITOR EFFECTIVENESS  
FOR THE DETECTION OF KRYPTON-85

by

W. A. Jester  
A. J. Baratta  
Nuclear Engineering Department  
R. W. Granlund  
Health Physics  
The Pennsylvania State University  
University Park, Pa. 16802

and

G. R. Eidam  
TMI Information and Examination  
EG&G Idaho  
P O Box 88  
Middletown, PA 17037

Presented at the  
1980 ANS/ENS International Conference  
Washington, D.C.  
November 19, 1980

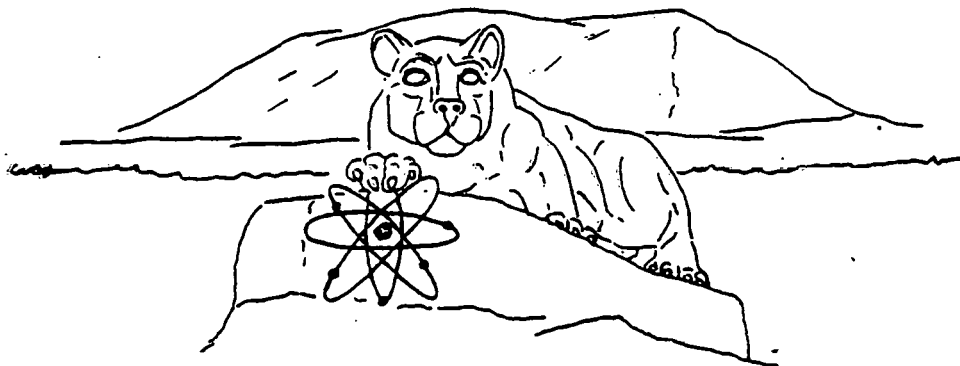

## ABSTRACT

As part of the preparations for the purging of TMI Unit-2, the krypton-85 sensitivity of 12 radiation detector systems or system combination was determined. Eleven of these were evaluated using a cube-shaped polyethylene-walled room containing a volume of  $5.6 \text{ m}^3$  ( $200 \text{ ft}^3$ ). Krypton-85 gas was added to produce a concentration of  $6.7 \times 10^{-6} \text{ } \mu\text{Ci/ml}$  in the test room. It was found that none of the ion chambers and scintillation detector systems were able to detect this concentration of krypton-85. Detectors employing thin window GM pancake probes were found to be sensitive enough to monitor this gas down to the unrestrictive area maximum permissible concentration level (MPC) of  $3 \times 10^{-5} \text{ } \mu\text{Ci/ml}$ , while a large window gas flow proportional counter was found to be sensitive enough to monitor down to about 0.1 MPC. At the end of this experiment,  $2.3 \text{ m}^3$  ( $80 \text{ ft}^3$ ) of the gas in the test room was pumped into a compressed air cylinder (scuba bottle) and was used to calibrate the PSU Noble Gas Monitor. The sensitivity of this system, which employs gas compression and Ge(Li) spectroscopy, was demonstrated to be between 0.1 and 0.03 times MPC, depending on the counting time employed.

## INTRODUCTION

Prior to the purging of the TMI-2 primary containment, a program was initiated to train citizens living near the plant to conduct radiation monitoring for their community.<sup>(1)</sup> In setting up this program, there developed considerable disagreement among program organizers as to which radiation monitoring system(s) should be utilized to monitor krypton-85. Thus, all concerned organizations were invited to submit their instruments of choice to a test which was conducted at the Breazeale Nuclear Reactor of The Pennsylvania State University between March 13 and March 18, 1980. This paper reports the results of this test.

## EXPERIMENTAL FACILITY AND PROCEDURES

A cubical test chamber 1.8 m (70 inches) on a side was built from 0.15 mm (6 mill) polyethylene sheeting sealed at the edges with duct tape. This chamber was supported by and suspended from a cubical aluminum frame 1.8 m (72 inches) on a side. Thus the room had a volume of about 5.6 m<sup>3</sup> (200 ft<sup>3</sup>). The entrance port into this test chamber, once the test room was sealed, was through the left side of a glove box centered on and sealed to one face of the test room (Fig. 1). Three test instruments having remote readouts were inserted into the test room prior to the injection of the trypton085. The sensitive detection volume for each detector was centered 0.9 m (35 inches) from the floor and well separated from one another so as to not significantly shadow the other detectors. The one pancake GM probe (Eberline HP-210) was centered on a side wall with the window side facing into the room. It was connected to an Eberline RM-14 exterior to the room. The other two detectors, a Reuter Stokes RSS-111 and

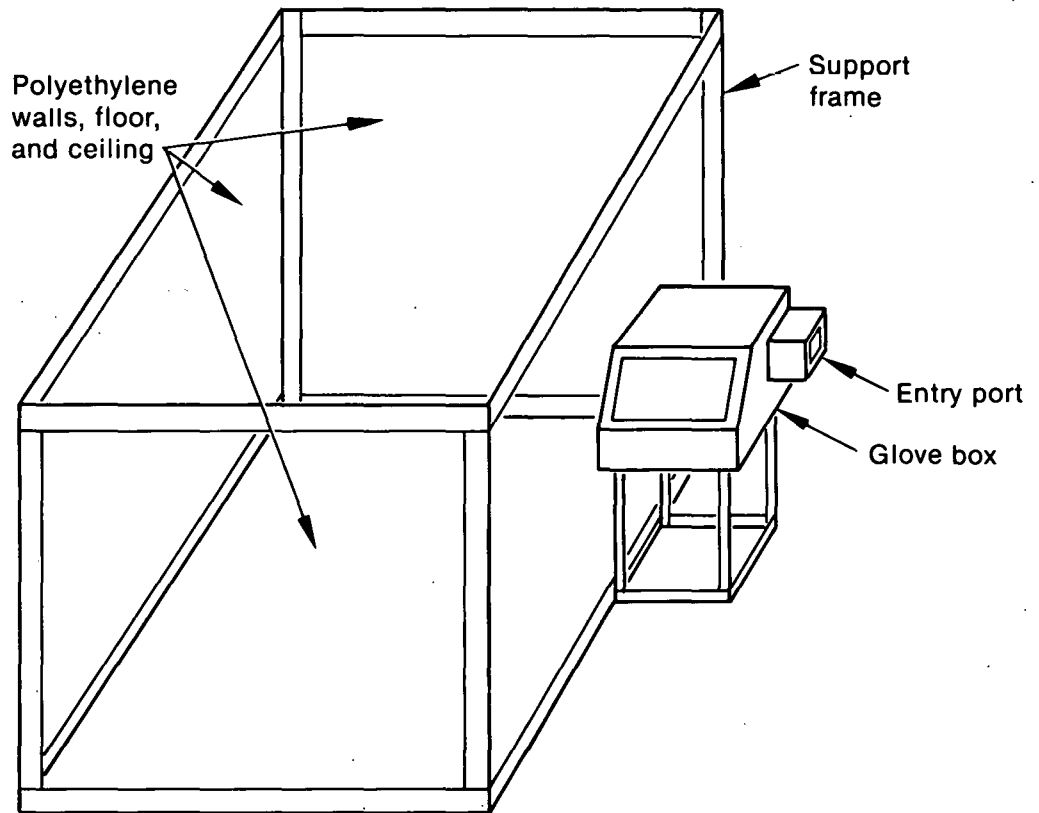

FIGURE 1: Krypton-85 Test Room.

a Kimmel MAB604, were located at adjacent corners one third of the way into the test room.

Instruments having no remote readout and various GM detector probes were placed into the glove box and inserted into the test room one at a time. An Eberline MS-2 scaler, and a Ludlum-2A rate meter, along with three types of GM probes, were also placed into the glove box. 0.3 cm thick aluminum absorber was attached as a beta shield for the GM pancake probes as needed.

One suitcase-type ion chamber, Learsigler 131500-1, did not have a remote readout and was too large for the glove box. Thus for most of the test it was located on a table outside the test room with its most sensitive location centered on and touching one of the plastic walls. Toward the end of the tests, a slit was made in one of the corners, the ion chamber was placed on the floor of the test room, and the room was quickly resealed. The output of this system was obtained from a strip chart at the end of the experiment.

Approximately 40 microcuries of krypton-85 was introduced into the test room, resulting in a concentration of  $6.7 \times 10^{-6}$   $\mu\text{Ci/ml}$  as determined by assaying samples of the air in a Cary one liter cylindrical ion chamber with a calibrated Cary model 32 electrometer. All readings were corrected for background. The test room was checked periodically for the krypton-85 concentration. For the 24-hour period of the tests, no change in this concentration was detected. This concentration is about 1.8 times lower than the  $1 \times 10^{-5}$   $\mu\text{Ci/ml}$  restricted area maximum permissible concentration (MPC) and about 22 times the  $3 \times 10^{-7}$   $\mu\text{Ci/ml}$  unrestricted area MPC as stated in 10 CFR Part 20, Appendix B. The unrestricted area MPC is that concentration in an infinite hemisphere which will give a beta skin dose

equivalent of 500 mrem in one year of continuous exposure.

At the end of the test period,  $2.3 \text{ m}^3$  ( $80 \text{ ft}^3$ ) of the air from the test room was pumped into a scuba bottle for the subsequent monitoring by the Penn State Noble Gas Monitor, <sup>(2)</sup> pressurizing the bottle to a pressure of  $2.1 \times 10^5 \text{ g/cm}^2$  (1200 psig). The plastic walls were untied from their supports and allowed to collapse around the instruments in the test room during the collection of this sample.

#### RESULTS USING THE KRYPTON-85 TEST ROOM

The results of the test conducted in the polyethylene room are given below and are summarized in Table 1.

##### 1. Ion Chambers

###### A. Reuter-Stokes Environmental Radiation Monitor Model RSS-111 (pressurized ion chamber)

This pressurized chamber was located in the test room. The background reading for this instrument was found to vary between 7.4 and 9.7  $\mu\text{R/hr}$ . After injection of the krypton-85, the readings varied between 8 and 10  $\mu\text{R/hr}$ . Thus there was no significant increase in measured dose rate from the krypton-85.

B. Tearesigler, Inc. Model 131600-1 Ion Chamber (suitcase-type) volume centered on one of the test room walls. The background reading was found to vary between 8 and 13  $\mu\text{R/hr}$ . After the injection of the krypton, the level was found to vary between 10 and 15  $\mu\text{R/hr}$ . When the instrument was inserted into the test room, no increase in the level was noted. Thus this instrument had no significant sensitivity to krypton-85 at the test level.



Table 1

Test Instrument Sensitivity to Krypton-85 at  $6.7 \times 10^{-6}$   $\mu\text{Ci/ml}$ 

Instruments Tested	Beta shield open		No beta shield or beta shield closed	
	Background	Kr-85	Background	Kr-85
	$\mu\text{R/hr}$	$\mu\text{R/hr}$	$\mu\text{R/hr}$	$\mu\text{R/hr}$
<b>Ion Chambers</b>				
Reuter Stokes, RSS-111 (Pressurized Ion Chamber)	NA <sup>(1)</sup>	NA	7-10	8-10
Learsigler, 131500-1 (Suitcase-type)	NA	NA	8-13	10-15
Eberline RO-2 (Portable Survey Meter)	100-500	300-700	100-500	100-500
<b>Scintillation Detectors</b>				
Kimmel, MAB604 (Plastic Scintillator)	3-6	13-16	3-6	5-7
Elliott Process Rate Meter, 1597A	NA	NA	5-8	6-8
	CPM	CPM	CPM	CPM
<b>GM Detectors</b>				
Eberline RM 14 ratemeter with Eberline HP 210 (Pancake Probe)	20-60	2000-2500	NA	NA

Table 1 (continued)

Instruments Tested	Beta shield open		No beta shield or beta shield closed	
	Background	Kr-85	Background	Kr-85
	CPM	CPM	CPM	CPM
Ludlum-2A rate meter with Eberline HP 210 and HP 260 (Pancake Probes)	20-80	2000-2200	20-60	100-140
Eberline MS2 with following probes:				
HP 210 (Pancake Probe)	20-60	1700-2500	20-60	140-200
HP 260 (Pancake Probe)	20-60	2300-2700	30-60	150-160
HP 270 (Energy Compensated)	20-30	40-100	20-30	20-30
Gas Flow Proportional Counter Eberline PAC-4G rate meter with Eberline AC21B Beta Probe	150-200	30,000-32,000	100-200	300-400

1 NA - Not applicable

2 Beta shield for GM detectors was a 0.3 cm aluminum absorber.

C. Eberline RO-2 Chamber (portable survey meter)

This detector was placed in the glove box for evaluation. The background level with and without the beta shield was between 0.1 and 0.5 mR/hr with the beta shield closed and 0.3 to 0.7 mR/hr with the beta shield open. Thus there is only a slight increase in activity due to betas penetrating into the sensitive volume.

2. Scintillation Detectors

A. Kimmel MAB604 Plastic Scintillator

This system was located in the test room. The background level with and without the beta shield cap was between 3 and 6  $\mu$ R/hr. With the krypton-85 present and the beta shield removed, the radiation level rose to between 13 and 16  $\mu$ R/hr, or an increase of about a factor of 3. At the end of the test, the beta shield was replaced over the crystal and the level fell down to near background level. Thus this system has some potential for detecting krypton-85 at or above the restricted area MPC, but will be of little use at or below the non-restricted area MPC.

B. Elliott Process Rate Meter Type 1597A (scintillation camera)

This hand-held monitor was evaluated from the glove box and had a background reading of from 5 to 8  $\mu$ R/hr. After introduction of the krypton-85, the range of readings was found to be about the same as the background readings. Thus this detector is of little use in monitoring krypton-85 at these levels.

3. GM Probes

A. Eberline HP-210 and HP-260 (GM pancake probes)

These two types of probes use the same model thin window GM tube in slightly different mountings. An HP-210 was mounted

centered on one wall of the test room and connected to an Eberline RM-14. This probe gave a background reading of between 20 and 60 cpm. After the introduction of the krypton-85, this count rate rose to a value of between 2000 and 2500 cpm.

An HP-210 and an HP-260 probe were also connected to an Eberline MS-2 scaler in the glove box. Both gave background readings of 20 to 60 cpm with and without beta shields attached. After the addition of the krypton-85, the HP-210 gave a count rate of between 1700 and 2500 cpm without a beta shield, and 140 to 200 cpm with a beta shield. The HP-260 gave a count rate between 2300 and 2700 cpm without a beta shield and 150 to 160 cpm with the beta shield in place.

The same HP-210 and HP-260 were also connected to a Ludlum Model-2A portable rate meter and tested in the glove box. Background readings for both instruments with and without beta shields were between 20 and 80 cpm. After the insertion of the krypton-85, the activity monitored by both detectors was found to be between 2000 and 2200 cpm without a beta shield and between 100 to 140 cpm with a beta shield in place. Thus these probes were among the most sensitive tested in this work.

B. Eberline HP-270 (GM probe with energy compensated shield)

This probe was connected to the MS-2 in the glove box. Background was found to vary between 20 and 30 cpm with the beta shield open or closed. With the beta shield in place, this detector recorded between 90 and 100 cpm when inserted into the test room and about 30 cpm with the beta shield closed. Thus this detector is not sufficiently sensitive to the krypton-85 betas to be useful.

4. Eberline PAC-4G with AC21B Beta Probe (gas flow proportional counter)

This system was evaluated from the glove box. It gave a background reading of between 100 and 200 cpm with and without a beta shield. In the presence of the krypton-85, it recorded between 30,000 and 32,000 cpm without a beta shield and between 300 to 400 cpm with the beta shield. Thus this was the most sensitive system tested.

Some problems were experienced in using this survey instrument because of the build-up of static electricity on the meter window. This may have been caused by the nylon lab coat worn by the operator.

#### CALIBRATION OF THE TMI AREA COMMUNITY MONITORING INSTRUMENTS

Considering the previously described test, as well as the authors' experience in equipment reliability and the availability of equipment on short notice, it was decided to supply each of the 12 communities taking part in this program with two instruments. The instrument chosen for use as a krypton-85 monitor was a Ludlum Model 177 rate meter with an Eberline HP-260 hand probe and a Rustrak Model 288 strip chart reader.<sup>(1,3)</sup> In addition, each community was supplied with a Learsigler 131500-1 ion chamber. Several of these systems were already in place and a large number of these weather-proofed suitcase-type instruments were available from EPA. The use of the gamma sensitive Learsigler and the beta sensitive Ludlum systems provided the TMI area community monitoring program the capability of distinguishing between the beta emitting krypton-85 and any other possible airborne gamma emitting radionuclides.

On April 13, 1980, as part of the Community Monitor Training Program, the 48 participants were brought to The Pennsylvania State University's Breazeale Nuclear Reactor. <sup>(1)</sup> They used the krypton-85 test room to calibrate their instruments. At this time, six of the Eberline HP-260 probes were evenly spaced along the walls of the test room 0.9 m (35 inches) above the floor. Each of these detectors was connected to a Ludlum-177 rate meter with its Rustrak recorder. Two of the Learsigler ion chambers were also placed in the room.

Approximately 115  $\mu\text{Ci}$  of krypton-85 was introduced into the test room, producing a concentration of  $2.1 \times 10^{-5}$   $\mu\text{Ci/ml}$  as measured with the previously described Cary Model 32 electrometer.

Even at a krypton concentration about 3 times that of the previous test, the Learsigler ion chambers showed no significant sensitivity to the presence of the krypton-85. The six Ludlum systems had average background readings between 25 and 30 cpm prior to the introduction of the krypton-85. After the gas was added, five of the six systems showed an average reading of between 4100 and 4300 cpm, resulting in a calibration factor of  $5 \times 10^{-9}$   $\mu\text{Ci/ml/cpm}$  (Table 2). One of the six systems gave an average value of 6000 cpm or a calibration factor of  $3 \times 10^{-9}$   $\mu\text{Ci/ml/cpm}$ . This latter value is in agreement with the values obtained in the first set of tests using a Ludlum-2A rate meter and an HP 260 probe. The difference between these two somewhat different sets of calibration factors may represent variations in window thickness occurring during the manufacture of the probes. Table 2 lists these calibration factors.

Table 2 also gives the estimated beta skin dose calibration factors assuming a uniform infinite hemisphere of krypton-85.

Table 2  
 Calibration Factors Used During  
 TMI-2 Purging

	$\mu\text{Ci/ml/cpm}$	$\mu\text{rem/hr/cpm}$
Ludlum-177 Rate Meter with Eberline HP-260	$5 \times 10^{-9}{}^1$ $(3 \times 10^{-9})$	$10 \times 10^{-1}{}^1$ $(6 \times 10^{-1}){}^2$
Eberline PAC-4G	$2 \times 10^{-10}$	$4 \times 10^{-2}$
PSU Noble Gas Monitor	$9.5 \times 10^{-8}$	18

- 1 Five instruments gave these calibration factors
- 2 One instrument gave this calibration factor as did an Eberline RMI4 rate meter with an Eberline HP-210 and a Ludlum-24 rate meter with an Eberline HP-210 or HP-260 probe.

## EPA USE OF PAC-4G GAS FLOW PROPORTIONAL COUNTERS

As the result of these tests, the EPA chose to use Eberline PAC-4G Gas Flow Proportional Counters with a Model AC21B Beta Probe on their mobile monitoring vans which operated during the purging of the TMI Unit-2 containment.<sup>(4)</sup> Based on this work, they used a calibration factor of  $2 \times 10^{-10}$   $\mu\text{Ci/ml/cpm}$  and  $6 \times 10^{-1}$   $\mu\text{rem/hr/cpm}$  (Table 2). These instruments were often able to locate the krypton-85 plume prior to the taking of compressed air samples.

## CALIBRATION OF THE PSU NOBLE GAS MONITOR

The PSU Noble Gas Monitor<sup>(2,5,6)</sup> is based on the principle of compressing air samples into a  $1.5 \times 10^5$  ml ( $0.5 \text{ ft}^3$ ) volume sphere surrounding a 50 cc Ge(Li) high resolution gamma-ray spectroscopy detector. The gas scuba bottle containing the krypton-85 air sample collected at the end of the first set of tests described in this paper was connected to the pressure vessel, and upon the opening of the interconnecting valves, the pressure was allowed to equalize between the two pressure chambers. This resulted in a common pressure of  $8.4 \times 10^4$   $\text{g/cm}^2$  (1200 psig). A 2000 second count of this sample gave a net count of 2350 counts in the 514 keV krypton-85 peak with a background of 8 counts. This gave a system calibration factor of  $9.5 \times 10^{-8}$   $\mu\text{Ci/ml/cpm}$  and 18  $\text{mrem/hr/cpm}$ , Table 2. These calibration factors were employed with this system during the monitoring program conducted during the purging of the TMI-2 containment. This sensitivity was a factor of 100 to 1000 times poorer than the sensitivity demonstrated by this system when monitoring for other



radioactive noble gases,<sup>(6)</sup> and results from the low photon yield (0.41%) of krypton-85. Based on this calibration data, the limits of detection of the system was found to vary from  $3 \times 10^{-8}$   $\mu\text{Ci/ml}$  for a 2000 second count to  $9 \times 10^{-9}$   $\mu\text{Ci/ml}$  for a 20,000 second count.<sup>(2)</sup>

## CONCLUSIONS

In retrospect one might wonder why there was any uncertainty as to the type of instruments which should be employed to monitor airborne emissions from the crippled TMI-2 plant. The only gaseous fission product remaining after a year of decay was the 10.76 year krypton-85. This radionuclide decays by beta emission 100% but emits only one gamma ray every 240 disintegrations. Also, beta sensitive detectors are invariably more efficient than gamma detectors, so it is not surprising that gas-filled detectors with thin end windows and large surface areas would be orders of magnitude more sensitive than those detectors that can detect only gamma rays. The initial resistance to the adoption of such instruments may reflect a lack of appreciation for the fact that radiation monitoring around a reactor which has been shut down a year may be different than radiation monitoring around an operating or recently shut down reactor, where short-lived gamma emitting radionuclides predominate.

Based on these tests, instruments were chosen which would detect and measure krypton-85 at or below unrestricted area mpc. These instruments were successfully used during the purging of krypton-85 from TMI-2 primary containment.<sup>(2,3,4)</sup>

## REFERENCES

1. A. J. Baratta, et al. "A Citizen's Radiation Monitoring Program for the TMI Area," Trans. of ANS, Vol. 35 (November 1980).
2. W. A. Jester, et al. "Monitoring Kr-85 during TMI-2 Purging Using the Penn State Noble Gas Monitor," Trans. of ANS, Vol. 35, (November 1980).
3. M. A. Reilly, "The Management of Kr-85 by a Community Monitoring Program," Trans. of ANS, Vol. 35 (November 1980).
4. E. W. Bretthauer, et al. "The Environmental Protection Agency's Radiation Monitoring and Surveillance Activities during the Purging of TMI-2," Trans. of ANS, Vol. 35 (November 1980).
5. R. H. Jabs, and W. A. Jester, "The Development of an Environmental Monitoring System for the Continuous Detection of Radioactive Gases," Nuc. Tec., Vol. 30 (July 1976).
6. W. A. Jester, and F. J. Hepburn, "A Ge(Li) System for the Monitoring of Low Levels of Radioactive Gases," Trans. of ANS, Vol. 36, p. 121 (June 1977).

## ACKNOWLEDGMENT

This work was supported by the Department of Energy through its contractor EG&G Idaho, Inc.

Appendix B

Training Program Outline

Handouts and Tests

Topical Outline for Training Participants  
for the Citizen Radiation Monitoring Program

DAY		TIME
1	A. Introduction to the Citizen Radiation Monitoring Program	3 hours
	B. Radioactivity <ol style="list-style-type: none"> <li>1. Introduction and Definition of Terms</li> <li>2. Radioactive Decay</li> <li>3. Conservation Laws</li> <li>4. Background Radiation and Sources</li> </ol>	
2	C. Interaction of Radiation with Matter <ol style="list-style-type: none"> <li>1. Introduction and Definition of Terms</li> <li>2. Interaction Mechanisms</li> </ol>	1.5 hours
	D. Methods of Radiation Detection <ol style="list-style-type: none"> <li>1. Introduction and Definition of Terms</li> <li>2. Detector Types</li> <li>3. Detector Sensitivities</li> </ol>	1.5 hours
3	E. Radiation Counting Variables <ol style="list-style-type: none"> <li>1. Introduction and Definition of Terms</li> <li>2. Systematic and Statistical Variables</li> </ol>	1.5 hours
	F. Laboratory Experiment GM Counting Experiment	1.5 hours
4	G. Radiation Protection Units <ol style="list-style-type: none"> <li>1. Activity</li> <li>2. Exposure Dose</li> <li>3. Absorbed Dose</li> <li>4. Equivalent Dose</li> </ol>	1.5 hours
5	H. Laboratory Experiment <ol style="list-style-type: none"> <li>1. Monitoring Equipment</li> <li>2. Familiarization and Krypton-85 Monitoring</li> </ol>	6 hours
6	I. Radiation Interaction in Biological Systems <ol style="list-style-type: none"> <li>1. Introduction and Definition of Terms</li> <li>2. Radiation Effects</li> <li>3. Regulations</li> </ol>	1.5 hours

DAY		TIME
	J. Laboratory Experiment Counting Statistics Laboratory	1.5 hours
7	K. Citizen Radiation Monitoring Program 1. Purpose 2. Organization 3. Equipment 4. Procedures	1.5 hours
	L. Three Mile Island Unit-2 1. The Accident 2. Proposed Methods of Cleanup	1.5 hours
8	M. Supervised Area Monitoring	3 hours
9	N. Supervised Area Monitoring	3 hours
10	O. Final Exam	1.5 hours
	P. Discussion of Community Radiation Monitoring Results and Observations	1.5 hours
11	Q. Meteorological Considerations 1. Introduction and Definition of Terms 2. Atmospheric Conditions Affecting Dispersion	1.5 hours
	R. Assignment of Personnel to Local Monitoring Teams	1.5 hours

Supplementary Reading Materials

for

Citizen Monitoring Program

by

William A. Jester  
Associate Professor of Nuclear Engineering  
The Pennsylvania State University

and

Janet Fay Jester  
Technical Writer

## Introduction

Much of the enclosed material was adapted from a soon-to-be published DOE document entitled "Electrical Energy: Policy and Prospects."

The sections utilized and modified from the above-mentioned documents were written and edited by the authors of this material.

## INDEX

Page

Chapter 1	Basic Nuclear Concepts
	Introduction
	Radiation Effects
	Radiation Detectors
	Units for Measuring Radiation Exposure
	Sources of Radiation
Chapter 2	Radiation Detection with a Geiger-Muller Detector
	Introduction
	Radiation Detector Variables
	Determinate Errors
	Background
	Geometry Factor
	Absorption of Radiation by Matter
	Experimental Procedures
Chapter 3	Studying the Statistical Nature of Radioactivity
	Introduction
	Discovery of Decay Statistics
	Binominal Distribution
	Radioactive Decay
	Experimental Procedures
Chapter 4	Radiation Health Effects
	Radiation Effect Studies
	Factors Which Influence Radiation Effects
	Biological Effects of Radiation
	Non-human Biological Effects
	Effects of Low-Level Radiation
Chapter 5	Nuclear Reactors
	Introduction
	The Fission Process
	Types of Reactors
	Safety Systems in Nuclear Reactors
	The Price-Anderson Act
	Wastes from Nuclear Power Plants
Chapter 6	The Events of Three Mile Island
	The Accident
	TMI-2 One Year Later
	Purging of TMI-2 Primary Containment
Appendix A	Glossary of Terms
Appendix B	The TMI Accident, As it Really Happened
Appendix C	Instruction Concerning Risk from Occupational Radiation Exposure



## Chapter 1

### BASIC NUCLEAR CONCEPTS

#### Introduction

The building block for all matter is the atom. An atom can be considered to be a dense core of particles called protons and neutrons forming a positively charged nucleus, surrounded by a swarm of negatively charged electrons. The nucleus is extremely small and dense compared to the whole atom. If an atom were the size of the Superdome, the nucleus would be the size of a peanut. But if a peanut were as dense as a nucleus, it would weigh about 100 million tons.

Different atoms have different numbers of neutrons, protons, and electrons. The number of protons in an atom, called the atomic number, determines the element of the atom. For example, an atom with 6 protons in the nucleus is an atom of carbon, while an atom with 11 protons is an atom of sodium (Table 1). It is also convenient to categorize atoms on the basis of the number of protons and neutrons in the nucleus. The term nuclide is used for any group of atoms having the same number of protons and neutrons. Thus, an atom with 35 protons and 44 neutrons is a nuclide of bromine, while an atom with 36 protons and 44 neutrons is a nuclide of krypton (Table 2). An isotope is one of a group of two or more nuclides having the same number of protons. For

Table 1  
LIST OF ELEMENTS

Atomic Number	Symbol	Name	Atomic Number	Symbol	Name
0	n	neutron	52	Te	tellurium
1	H	hydrogen	53	I	iodine
2	He	helium	54	Xe	xenon
3	Li	lithium	55	Cs	cesium
4	Be	beryllium	56	Ba	barium
5	B	boron	57	La	lanthanum
6	C	carbon	58	Ce	cerium
7	N	nitrogen	59	Pr	praseodymium
8	O	oxygen	60	Nd	neodymium
9	F	fluorine	61	Pm	promethium
10	Ne	neon	62	Sm	samarium
11	Na	sodium	63	Eu	europium
12	Mg	magnesium	64	Gd	gadolinium
13	Al	aluminum	65	Tb	terbium
14	Si	silicon	66	Dy	dysprosium
15	P	phosphorus	67	Ho	holmium
16	S	sulfur	68	Er	erbium
17	Cl	chlorine	69	Tm	thulium
18	Ar	argon	70	Yb	ytterbium
19	K	potassium	71	Lu	lutetium
20	Ca	calcium	72	Hf	hafnium
21	Sc	scandium	73	Ta	tantalum
22	Ti	titanium	74	W	tungsten
23	V	vanadium	75	Re	rhenium
24	Cr	chromium	76	Os	osmium
25	Mn	manganese	77	Ir	iridium
26	Fe	iron	78	Pt	platinum
27	Co	cobalt	79	Au	gold
28	Ni	nickel	80	Hg	mercury
29	Cu	copper	81	Tl	thallium
30	Zn	zinc	82	Pb	lead
31	Ga	gallium	83	Bi	bismuth
32	Ge	germanium	84	Po	polonium
33	As	arsenic	85	At	astatine
34	Se	selenium	86	Rn	radon
35	Br	bromine	87	Fr	francium
36	Kr	krypton	88	Ra	radium
37	Rb	rubidium	89	Ac	actinium
38	Sr	strontium	90	Th	thorium
39	Y	yttrium	91	Pa	protactinium
40	Zr	zirconium	92	U	uranium
41	Nb	niobium	93	Np	neptunium
42	Mo	molybdenum	94	Pu	plutonium
43	Tc	technetium	95	Am	americium
44	Ru	ruthenium	96	Cm	curium
45	Rh	rhodium	97	Bk	berkelium
46	Pd	palladium	98	Cf	californium
47	Ag	silver	99	Es	einsteinium
48	Cd	cadmium	100	Fm	fermium
49	In	indium	101	Md	mendelevium
50	Sn	tin	102	No	nobelium
51	Sb	antimony	103	Lw	lawrencium



example, one nuclide of chlorine has 17 protons and 20 neutrons in its nucleus, while another nuclide of chlorine has 17 protons and 18 neutrons in its nucleus. These two different nuclides are said to be isotopes of chlorine, and they are designated chlorine-37 and chlorine-35 for the sum of their neutrons and protons. There are approximately 1800 known nuclides.

All nuclides can be placed into one of two categories: radioactive or stable. Radioactive nuclides (radionuclides) undergo spontaneous nuclear changes which transform them into other nuclides. This transformation is called radioactive decay, and through the decay the radioactive nuclide is changed eventually into a stable nuclide.

There are 265 stable nuclides and 66 radionuclides found in nature. All the rest of the nuclides are man-made radionuclides.

In changing into a stable state, the nucleus of a radioactive atom emits radiation. Radiation may be in the form of particles, or in the form of electromagnetic rays called photons. Some radionuclides decay by the emission of alpha particles, which are high energy helium nuclei. Others decay by the emission of beta particles, which can be either negatively charged electrons (negatrons) or positively charged electrons (positrons). Decay by the emission of these particles is usually followed by the emission of photons of two types: gamma rays, which are produced in the nucleus of the decaying atom, and x-rays, which are produced as a result of the rearrangement of orbital electrons. Except for their origin and the fact that x-rays are usually lower in energy and therefore less penetrating, x-rays and gamma rays are the same.

Loss of this radiation changes the atomic structure of the radioactive nuclide, a process which continues until a stable (nonradioactive) nuclide is reached. Uranium, for instance, is radioactive; it decays slowly into

elements like radium, radon, and polonium, and finally stops at lead, which is a stable nuclide.

The time it takes for a radionuclide to decay into another nuclide can vary from millionths of a second to billions of years. The term that is most commonly used to describe this time is the half life. The half life of a radionuclide is the time it takes for one half of the atoms in a given sample of the radionuclide to decay. Thus, after one half life, half of the original radionuclide is left; after two half lives, one-fourth remains; and after twenty half lives, only one-millionth is left. Each radionuclide has its own characteristic half life, and the half life cannot be changed by any known means. As an example, the half life of copper-67 is 61.7 hours. This means that a sample that starts out with 6 billion atoms of copper-67 will have half that number, or 3 billion atoms of copper-67, remaining at the end of 61.7 hours. In another 61.7 hours, it will have only 1.5 billion atoms left. Eventually, after several weeks, nearly all of the copper-67 will have decayed into zinc-67, which is a stable nuclide.

The rate at which radioactive material decays is described by the curie unit. As shown in Table 3, a curie is  $3.7 \times 10^{10}$  disintegrations per second which means that in each second there are 37 billion atoms decaying (Table 4). There is often a great deal of confusion about the prefix terms often used with curie and other radiological units. As shown in Table 4, a megacurie is one-million curies which is a very large amount of radioactivity, while a microcurie is one one-millionth of a curie and is a rather small amount of radioactivity.

Radioactivity is all around us. Natural sources include cosmic rays from space, and radionuclides in stone, soil, water, food, and even our own bodies. Man-made sources include medical x-rays, nuclear weapons, fallout, and television sets and other consumer products.

### Radiation Effects

As noted above, all matter is made up of units called atoms. Each atom has

Table 3

## RADIOACTIVE UNITS

		<u>Disintegrations each second</u>	<u>Curies</u>
1 megacurie	=	$3.7 \times 10^{16}$	$10^6$
1 kilocurie	=	$3.7 \times 10^{13}$	$10^3$
1 curie	=	$3.7 \times 10^{10}$	1
1 millicurie	=	$3.7 \times 10^7$	$10^{-3}$
1 microcurie	=	$3.7 \times 10^4$	$10^{-6}$
1 nanocurie	=	$3.7 \times 10^1$	$10^{-9}$
1 picocurie	=	.037	$10^{-12}$

Table 4

Prefixes for Units

<u>Prefix</u>	<u>Symbol</u>	<u>Power</u>	<u>Common Name</u>	<u>Meaning</u>
tetra -	T	$10^{12}$	trillion	1,000,000,000,000
giga -	G	$10^9$	billion	1,000,000,000
mega -	M	$10^6$	million	1,000,000
kilo -	k	$10^3$	thousand	1,000
hecto -	h	$10^2$	hundred	100
deka -	da	$10^1$	ten	10
deci -	d	$10^{-1}$	tenth	0.1
centi -	c	$10^{-2}$	hundredth	0.01
milli -	m	$10^{-3}$	thousandth	0.001
micro -	$\mu$	$10^{-6}$	millionth	0.000,001
nano -	n	$10^{-9}$	billionth	0.000,000,001
pico -	p	$10^{-12}$	trillionth	0.000,000,000,001

a nucleus with an electrically positive charge. A cloud of electrically negative electrons surround the positive nucleus. Ordinarily, the number of negative electrons equals the number of positive charges in the nucleus. The atom is then electrically neutral. If energy is supplied to an electron, it can be moved to a position further from the nucleus; then the atom is said to be in an excited state. If large amounts of energy are supplied, the electron can escape from the atom completely. When one or more electrons are separated from the atom, the atom is said to be ionized. The atom has a net positive charge since it is missing an electron. This positively charged atom, taken with its separated negative electron, is called an ion pair. Radiation produced by nuclear reactions and by radionuclide decay can supply the energy needed to excite an atom or for ion pairs. Thus, it is often called ionizing radiation.

When ionizing radiation passes through matter, it interacts with the electron clouds of the atoms in the matter. In this process, the radiation loses its energy by exciting the atoms and/or producing ion pairs in the matter. This basic process is essentially the same for all kinds of materials - air, water, people, cement blocks, or steel.

The potential for injury or damage from any kind of radiation depends on the rate of energy loss as the radiation travels through matter. This rate of energy loss in turn depends on the type of radiation, its electrical charge, and its energy. The energy deposited by the radiation in the absorbing matter causes changes in the matter, such as the production of ion pairs. These changes can result in damage to the matter, including disruption of the functions of cells of living organisms.

The most penetrating type of decay radiation is the gamma ray. High energy gamma rays can completely penetrate a person, a concrete block or a sheet of lead.

Beta radiation, which is high energy positive or negative electrons, is capable of penetrating a piece of aluminum foil or several layers of a person's skin. In air, its range may be as much as a yard.



Alpha radiation, which is high energy helium nuclei, can sometimes penetrate a very thin piece of paper, but cannot penetrate conventional aluminum foil. However, alpha particles are the most hazardous of all types of radiation if they enter the body as a result of swallowing or inhaling an alpha emitter.

### Radiation Detection

Radioactivity is not detectable by the human senses except in massive doses, but it is easily detected by several types of instruments. One of the simplest radiation detectors is ordinary photographic film, which darkens on exposure to radiation and is routinely used in film badges for measuring the cumulative amount of exposure received by people who work with sources of radiation. Other types of detectors, such as Geiger counters, ionization chambers, and proportional counters, are used to detect the presence and measure the intensity of radiation. These instruments can detect the presence of extremely small amounts of radioactive materials. Radiation detection is also very sensitive in its ability to identify specific radioactive substances. This is possible because every species of radioactive atom has a unique pattern of radioactive decay with respect to type of radiation and energy level.

### Units for Measuring Radiation Exposure

The roentgen is the unit of exposure related to the number of ion pairs produced in air by x-rays and gamma rays. It is the amount of such radiation required to produce ions carrying a standard electrical charge in a standard amount of air. The roentgen can be measured directly since the electric current can be measured by an ammeter.

The radiation absorbed dose (rad) indicates the amount of energy deposited in material by any type of ionizing radiation. It is a measurement

of not only ion pairs, but of all energy deposited. A rad is a very small unit. For example, one rad equals the energy required to raise the body temperature by two-millionths of a degree of Fahrenheit.

The roentgen equivalent man (rem), is the unit of dose equivalent. It is a measure not only of energy deposited but also the resulting biological effects.

For instance, suppose 500 rads of gamma rays produce a certain change in a tissue and 50 rads of alpha particle radiation produce the same change. We then would say that the alpha radiation was 10 times as powerful as gamma radiation in causing this change. In other words, the alpha radiation would have a quality factor of 10 when compared to the gamma ray.

We can use the formula  $\text{rems} = \text{rads} \times \text{quality factor}$  to convert from rads to rems. In our example, the quality factor for gamma radiation is 1. Therefore, 500 rads multiplied by a quality factor of 1 gives 500 rems. For the alpha radiation, 50 rads multiplied by a quality factor of 10 gives 500 rems. The number of rems is thus the same for the two types of radiation which produced the same biological effect.

Since radiation protection deals with the safeguarding of people from unnecessary radiation exposure, regulations and recommendations are usually written in terms of rems, which take into account the biological effects of the radiation. However, it is often desirable to work with smaller units, so the term millirem (mrem), which is one-thousandth (.001) of a rem, is often used. For example, the maximum permissible exposure allowed for a radiation worker is 5 rems, or 5,000 mrem, per year.

To describe radiation exposure to groups of people, the term person-rem is used. The person-rem indicates the total exposure of all members of a certain population. For example, consider a group of 50 people. If each of the 50 people receives one rem, the population dose is 50 person-rems. If 25 people

receive one rem and 25 people receive no exposure, the population dose is 25 person-rems. If one person receives 25 rem and the rest receive no exposure the population dose is 25 person-rems.

To summarize the units of radiation exposure, a roentgen refers to the ions produced in air by x-rays and gamma rays. A rad refers to the energy deposited in any material by any ionizing radiation. A rem indicates the results of that energy deposited in tissue, and the term person-rem indicates total exposure of the population.

### Sources of Radiation

Radiation is everywhere in our environment. The radiation we receive comes both from natural or background radiation and from man-made radiation. Our radiation dosage is about equally split between these two, with an average of close to 100 mrem per year coming from each category.

The intensity of natural radiation varies from time to time and from place to place. One source of this natural radiation is high energy cosmic radiation from the sun and stars. The cosmic radiation dose increases with altitude, so that people who live in higher elevations receive more exposure than those who live at sea level. Taking an airplane trip also increases exposure to cosmic radiation.

Another source of natural radiation is radioactive nuclides in soil, rock, and even our bodies. Uranium and thorium are widely distributed in soil and rock. Because of this, people who live in houses made from stone or brick receive significantly more natural radiation than those who live in houses made from wood. Our bodies and the food we eat contain radioactive nuclides such as potassium-40 and carbon-14.

The air that surrounds us and which we breath contains Radon-220 and Radon-222, again from uranium and thorium.

Table 5 shows the average dose from natural radiation in the U.S. Man-made radiation adds to the average dose that everyone receives. Most significant is the dose from medical and dental x-rays. A small amount of radioactivity is also received from fall-out from weapons testing and from nuclear reactors. Table 6 gives some examples of man-made radiation exposures that give an average of 100 mrem per year to everyone in the U.S.

TABLE 5

## Natural Sources of Radiation in U.S.

<u>Source</u>	<u>Dose Rate</u> <u>mrem per year</u>
Cosmic Radiation	
1. at Sea Level	40
2. add 1 mrem for every 100 feet of elevation.	—
Example: Harrisburg area 400 feet above sea level, add 4.	
Natural Occurring Radionuclides	
1. Radionuclides in ground (U.S. average)	15
2. Home construction materials	—
wood - add 35	
concrete - add 50	
stone - add 70	
brick - add 75	
3. Food and drinking water (U.S. average)	25
4. Air (U.S. average)	<u>5</u>
TOTAL:	130



## Chapter 2

### RADIATION DETECTION WITH A GEIGER-MULLER DETECTOR

#### Introduction

One of the most commonly used and sensitive instruments for the detection of radiation is the Geiger-Muller detector. This name is sometimes abbreviated to Geiger or GM detector. This detector consists of a tube filled with a counting gas at a pressure of about 10% of atmospheric pressure. Within the tube and separated by the gas are two terminals with a potential difference of 900 volts. As long as there is no radiation entering the gas, there is no flow of electrical current between the two electrodes. When a particle of radiation passes into the tube, it causes ionization of the gas. This momentarily closes the circuit and sends a pulse of electricity through the electrical circuit connected to the tube. The tube is designed in such a way that the pulse is amplified. If one is interested in determining the number of particles entering the tube in a given amount of time, then the GM detector is connected to a device called a scaler which is merely an electrical adding machine that counts the pulses sent by the detector. A scaler usually contains a clock which can be set for the desired counting time. Sometimes the GM detector is connected to a rate meter which shows the rate in units such as counts per minute at which the particles are being detected. A scaler is more accurate than a rate meter, but a rate meter gives a more rapid indication about changes in radiation levels.

5

A GM counter system cannot in itself tell what type of radiation a person is counting. That is, it cannot distinguish between gamma photons or beta or alpha particles. The experiment will give some methods which can be used to identify the type of radiation being counted.

#### RADIATION DETECTION VARIABLES

There are a number of factors which can cause variations in the amount of radiation being counted by a GM detector. It is important when using such detectors to have an understanding of these sources of variation and errors in order to properly interpret the meaning of a detector reading.

Some of these variables are called determinate errors. These include constant and systematic errors which will be the subject of this experiment. Other variables are called indeterminate errors, and these include random, accidental, and observational errors.

#### DETERMINATE ERRORS

Determinate errors are those factors that cause the measured activity to be different from the true activity of the sample. They can either be eliminated through careful planning and control of the measurement, or their magnitude can be determined and the final results corrected for the error. The determinate errors that we will investigate in this experiment are background, geometry factor, and the absorption of the radiation by matter.

#### BACKGROUND

When no obvious source of radiation exists in the vicinity of a GM detector, it will still detect a small amount of radioactivity called



background radiation. A typical background may vary between 10 and 100 counts per minute, depending on the design of the detector, location of the detector, and the time the reading is taken. There are two types of background: natural sources and artificial sources.

A. Natural Sources

1. Cosmic Rays

This source of background is caused by charged particles from space bombarding the earth's atmosphere. It will change with location on the earth and with sun spot activity.

2. Natural Radioactivity in the Surroundings

This includes uranium and thorium and their daughter radionuclides in the soil and in building materials, carbon-14 in wood and carbon-containing compounds, carbon-14 and potassium-40 in the body, and radon radioisotopes and their daughter products in the air.

B. Artificial Radioactivity in the Surroundings

This includes such man-made items as watches and other objects painted with luminous paint, radioactive materials stored nearby, X-ray radiation generated by a variety of electrical and electronic equipment, contamination of the counting equipment during previous use, and radiation fallout from weapons testing.

In determining the radioactivity of an object, one must first determine the background activity of the area. The background must then be subtracted from the activity while monitoring an object in order to obtain the activity from the object alone.

## GEOMETRY FACTOR

Just as the intensity of a light falls off as one gets farther away from the light, the intensity of radiation also falls off the farther one gets from the source of radiation. For a small radiation source, the number of counts being detected by a detector will decrease as the square of the distance. This is called the inverse square law. This distance is one of the factors in radiation protection; namely, the farther one is from a strong source of radiation, the safer he is.

## ABSORPTION OF RADIATION BY MATTER

Alpha, beta, and gamma radiations are each absorbed in matter in different ways. Alpha radiation loses its energy over a short distance in matter and cannot even penetrate the dead layer of cells covering the skin. Thus, alpha emitters are not considered a hazard unless they are somehow taken into the body through the air we breathe or the water and food which we consume. The alpha particles emitted by the polonium-210 source used in this work have an energy of 3.3 Mev and will be completely stopped by about 0.73 inches of air. Beta particles are more penetrating than alpha particles even though they usually have lower energies. Thus, since they lose their energy in a larger volume of matter, they cause less damage. The beta emitter used in this experiment is a strontium-90 - yttrium-90 source having a maximum energy of 2.3 Mev. This energy beta particle can penetrate about 0.4 inches into the skin and has a range in air of about 25 feet. Beta particles are considered to be both an external hazard to the skin as well as an internal hazard if taken into the body.

We cannot talk about a maximum range for gamma rays. We can talk only about an average range. The gamma source used in this experiment is cobalt-60, having a maximum energy of 1.33 Mev. It will take about 6.5 inches of tissue

to absorb half the radiation and about 470 feet of air to absorb half the radiation from cobalt-60. But it will take only about 0.6 inches of lead to absorb half the radiation.

When talking about absorption of radiation in these terms, one must not confuse it with the geometry factor. The source and the detector are kept at a constant distance apart, and the comparison is made between the activity observed with no matter between the source and detector and with the absorbing matter placed between the source and detector.

Because of their ability to penetrate matter, gamma sources are considered to be a whole body hazard whether they are inside or outside the body. This experiment demonstrates the value of placing high-density radiation shielding such as lead or concrete between a person and a high-level radioactive source.

## EXPERIMENTAL PROCEDURES

### Part I: Set-up and Background Measurements

1. Plug in the power cords for the Ludlum, Model 177 Alarm Rate Meter and its Rustrak Recorder.
2. Set the range switch at "X 1," its response switch to a slow, and the power switch to ON.
3. Pull down the recorder window and record the time and date you started the instrument and then close the window.
4. Being sure that there are no radioactive sources near your detector, allow the instrument to run for 5 minutes and observe the needle on the counts per minute meter. Observe the maximum and minimum count rate and estimate the average count rate for the 5-minute period.

Record your observations below.

Maximum count rate \_\_\_\_\_

Minimum count rate \_\_\_\_\_

Average count rate \_\_\_\_\_

5. At the end of the 5-minute counting period, using the wheel on the recorder face, advance the tape until you can see the trace clearly beneath the window. Record the stop time on the tape. From the points on the tape, determine the following information:

Maximum count rate \_\_\_\_\_

Minimum count rate \_\_\_\_\_

Average count rate \_\_\_\_\_

QUESTION: How do your results compare from steps 4 and 5?

6. Set the response switch to FAST and again count for 5 minutes, recording the start time on the tape. Again, observe the maximum count rate, the minimum count rate, and estimated average count rate for the background during this period of time. Record your observations below.

Maximum count rate \_\_\_\_\_

Minimum count rate \_\_\_\_\_

Average count rate \_\_\_\_\_

7. At the end of the 5-minute counting period, again advance the tape until you can read it and report the stop time on the tape. From the points on the tape, record the following information:

Maximum count rate \_\_\_\_\_

Minimum count rate \_\_\_\_\_

Average count rate \_\_\_\_\_

QUESTION: How do the results compare from steps 6 and 7?

The RESPONSE switch fast position makes the rate meter respond more quickly to the fluctuations of the radiation than in the slow position.

QUESTION: In which response position is it easier to determine the average background?

## Part II: Geometry Factor and Radiation Attenuation

### A. Alpha Source

1. Using tweezers to handle the source, position the alpha source 1/4 inch beneath the wire screen of the detector, with the hole side toward the detector. You will have to adjust the range switch to a higher scale. Using the count rate meter, read off the average counts per minute. Do not leave the source in this position for more than one minute before going to the next step.

Alpha source 0.25 inches from detector \_\_\_\_\_ counts/min  
Measurement minus average background \_\_\_\_\_ counts/min  
from Part I, step 5.

2. Without moving the source, insert absorber number 2 on top of the source and record the observed counts per minute. This absorber is aluminum foil having a thickness of about 0.0005 inches.

Alpha source with absorber number 2 on top \_\_\_\_\_ counts/min  
Measurement minus average background \_\_\_\_\_ counts/min

3. Remove the absorber and adjust the distance between the detector wire screen and the alpha source to 1 inch and estimate the activity.

Alpha source one inch from detector \_\_\_\_\_ counts/min  
Measurement minus average background \_\_\_\_\_ counts/min

QUESTIONS: How do the measurements made in steps 2 and 3 compare with background?

Why isn't the high count rate observed in step 1 seen in steps 2 and 3?

Explain how geometry and absorption factors caused a reduction in the measured alpha activity.

B. Beta Source

1. Using tweezers to handle the source, position the beta source 1/4 inch from the detector and record its counts per minute.

Beta source 0.25 inches from detector \_\_\_\_\_ counts/min

Measurement minus background \_\_\_\_\_ counts/min

2. Without moving the source, insert absorber number 2 on top of the source and record the observed counts per minute.

Beta source with absorber number 2 on top \_\_\_\_\_ counts/min

Measurement minus background \_\_\_\_\_ counts/min

3. Remove the absorber and adjust the distance between the detector and the source to 1 inch and record the counts per minute.

4. Place absorber number 21 on top of the source and record the counts per min. This aluminum absorber is about 1.6 inches thick.

Beta source with absorber number 21 \_\_\_\_\_ counts/min

Measurement minus background \_\_\_\_\_ counts/min

Compare the beta and alpha activity recorded in the two positions and with absorber number 2 in place.

QUESTION: Which type of radiation is more penetrating?  
How did the beta activity with absorber number 21 in place compare with background activity?

Explain how geometry and absorption factors caused a reduction in the measured beta activity.

#### C. Gamma Source

1. Using tweezers to handle the source, position the gamma source 1/4 inch from the detector and record its counts per minute.

Gamma source 0.02 inches from detector \_\_\_\_\_ counts/min

Measurement minus background \_\_\_\_\_ counts/min

2. Without moving the source, insert absorber number 2 on top of the source and record the observed counts per minute.

Gamma source with absorber number 2 on top \_\_\_\_\_ counts/min

Measurement minus background \_\_\_\_\_ counts/min



NOTE: Cobalt-60 is both a beta and gamma emitter, but most of the beta particles are absorbed in the plastic source button. If no betas are reaching the detector, the measurement from 1 should be essentially the same as that of measurement 2.

QUESTION: Is there any evidence that part of the measured activity is from beta particles?

3. Remove the absorber and adjust the distance between the detector and the source to 1 inch and record the counts per minute.

Gamma source one inch from the detector \_\_\_\_\_ counts/min

Measurement minus background \_\_\_\_\_ counts/min

4. Place absorber 21 on top of the source and record the counts per minute.

Gamma source with absorber number 21 \_\_\_\_\_ counts/min

Measurement minus background \_\_\_\_\_ counts/min

5. Place aluminum absorber 25 on top of the source and record the counts per minute.

Gamma source with absorber number 25 \_\_\_\_\_ counts/min

Measurement minus background \_\_\_\_\_ counts/min

6. Place lead absorber E on top of the source and record the counts per minute. This absorber is about the same thickness as the aluminum source used in 5 above.

Gamma source with absorber number E \_\_\_\_\_ counts/min

Measurement minus background \_\_\_\_\_ counts/min

Compare the effects of distance and absorbers on gamma rays with the effects on alpha and beta particles/

Question: How did the two absorbers of different density affect the absorption of the gamma radiation?

Considering the results of the experiment, how can you use absorbers to tell if the radiation you are detecting is primarily gamma rays or beta or alpha particles.

## STUDYING THE STATISTICAL NATURE OF RADIOACTIVITY

## INTRODUCTION

Besides the systematic errors for which we can correct our measurements, there are several sources of errors which are beyond our control to correct. These include observational errors which happen when we either read the results wrong from the instrument or copy it wrong when we write it down. There is also instrumental errors which occur when a momentary malfunction of some component of the detector system or a fluctuation in line voltage powering the instrument. There can also be a momentary increase in activity due to an increase in background caused by such events as cosmic ray showers or by the passing of a radioactive source near the detector. Finally, there is the normal random fluctuations which result from the radioactive decay process itself. In this experiment we will look at the fluctuations of both background and a radioactive source.

## DISCOVERY OF DECAY STATISTICS

Very early in the history of radioactivity, it was recognized that there are statistical fluctuations in the number of disintegrations from a radioactive source for any particular time interval. In 1910, Rutherford and Geiger performed an important experiment which showed that these fluctuations followed well known laws of statistics.

They found that in counting the alpha particles emitted from radioactive substances, that while the average number of particles from a steady source is nearly constant, when a large number were counted, the number appearing in a given short interval was subject to wide fluctuations. These variations were especially noted when only a few disintegrations occurred per minute. For example, during a considerable interval it may happen that no alpha particles appeared; then followed a group of particles in rapid succession then occasional alpha particles, and so on.

It was important to determine whether these variations in the distribution were in agreement with the laws of probability, that is, whether the distribution of alpha particles on an average was that which would be anticipated if the alpha particles are expelled at random. It might be conceived, for example, that the emission of alpha particles might lead to the disintegration of neighboring atoms, and so lead to a different distribution law.

Their work indeed confirmed the validity of using the laws of probability in the study of radioactive decay.

If one had the ability to isolate a single radioactive atom and watch it until it decayed, there would be no method currently available to us to predict at exactly which instant the decay would take place. On the other hand, by use of statistical methods, if one has a large number of atoms, it becomes possible to predict how many atoms will decay within a certain period of time. This situation is comparable to that confronting the life insurance companies. When they insure a single life, they have no means of predicting exactly how long that individual will live. If, however, they consider a large number of lives, it then becomes possible for them to predict how many of the insured will die during a particular period of time. It can be seen that the larger the number of atoms or the greater the number of people considered in such a calculation, the more accurate will be the prediction percentage-wise.

#### BINOMIAL DISTRIBUTION

Any situation which can randomly have either one of two outcomes in a measurement or a time interval is described by a binomial distribution. For example, consider the case of tossing a coin. We can get either a head or a tail in each if we made ten tosses, we could get any one of 11 possible combinations as shown in Table I below:

Table I  
Binomial Distribution for Ten Coin Tosses

<u>Number of Heads</u>	<u>Tails</u>	<u>Probability Distribution (Fraction)</u>	<u>Probability Distribution (Percent)</u>
0	10	$\frac{1}{1024}$	.1
1	9	$\frac{10}{1024}$	.0
2	8	$\frac{45}{1024}$	4.4
3	7	$\frac{120}{1024}$	11.7
4	6	$\frac{210}{1024}$	20.5
5	5	$\frac{252}{1024}$	24.6
6	4	$\frac{210}{1024}$	20.5
7	3	$\frac{120}{1024}$	11.7
8	2	$\frac{45}{1024}$	4.4
9	1	$\frac{10}{1024}$	1.0
10	0	$\frac{1}{1024}$	0.1
Total -----		$\frac{1024}{1024}$	100.0

If you would keep a record of the number of heads and tails in a group of ten tosses, you would find that on the average you would get one group of ten heads only one in 1024 trials. You would also get only one group of ten tails in the 1024 trials. As expected, the combination which occurs most frequently is five heads and five tails, which occurs on the average of 252 times out of the 1024 trials, or about one quarter of the time. In this example, the mean or average value is five heads out of ten tosses. That is, if you record the results of all trials, the number of trials having more than five heads will be balanced by the number of trials having less than five heads.

#### RADIOACTIVE DECAY

The binomial distribution applies to radioactive decay. In a given time period, some of the radionuclide atoms in a sample will decay while the rest will not. If two conditions hold, we can describe the probability distribution that we can expect from a series of measurements. These two conditions are that the number of counts observed in each measurement exceeds 100 counts and the half-life is large, at least seven times the observation time.

Two factors are used to describe the distribution of continuing measurements. The first is the average or mean value ( $m$ ) obtained by adding up all the counts obtained on all the measurements and then dividing by the number of measurements. The second is the standard deviation,  $\sigma$ , which describes the spread of the measurements about the mean. The standard deviation is obtained by taking the square root of the mean value. For example, if the mean value from a series of counts was 1,000 counts, the standard deviation would be the square root of 1,000 or about 32.

The distribution about the mean value is described in Table II.

Table II  
The Binomial Distribution of Counts about a Mean Numeral Range

<u>Range</u>	<u>Numeral Range Counts in Example</u>	<u>Probability Distribution (Percent)</u>
0 to $m-3\sigma$	0 to 905	0.1
$m-3\sigma$ to $m-2\sigma$	906 to 937	2.1
$m-2\sigma$ to $m-\sigma$	938 to 967	13.6
$m-\sigma$ to $m$	968 to 1,000	34.2
$m$ to $m+\sigma$	1,001 to 1,032	34.2
$m+\sigma$ to $m+2\sigma$	1,033 to 1,062	13.6
$m+2\sigma$ to $m+3\sigma$	1,063 to 1,095	2.1
$m+3\sigma$ and larger	1,096 and larger	0.1
	Total -----	100.0

Our example problem is illustrated in this table. The mean value,  $m$ , is equal to 1000. Our standard deviation,  $\sigma$ , is equal to 31.6. Thus,  $m-\sigma$  equals 1000-32 or 968, while  $m+\sigma$  equals 1000+32 or 1032. Likewise,  $m-2\sigma = 1000-63$  or 937, while  $m+2\sigma$  equals 1063, and-so-forth. Thus, if our measured count was found to be 985, it would fall between  $m-\sigma$  and  $m$  while if another count was found to be 1076 it would fall between  $m+2\sigma$  and  $m+3\sigma$ .

## EXPERIMENTAL PROCEDURES

### Part 1 Set-up and Measurement of the Variation of Background Radiation.

1. As directed by your instructor, connect the electronic scaler either directly to the detector or to the signal connection located on the back of the Ludlum Alarm Rate meter.
2. Allow the scaler to warm up for five minutes.
3. Set the timer for thirty seconds.
4. With all radioactive sources well away from the detector, take and record below 20 measurements.

Measurement  
Number

1.	_____	16.	_____
2.	_____	17.	_____
3.	_____	18.	_____
4.	_____	19.	_____
5.	_____	20.	_____
6.	_____		
7.	_____		
8.	_____		
9.	_____		
10.	_____		
11.	_____		
12.	_____		
13.	_____		
14.	_____		
15.	_____		

Total = \_\_\_\_\_



5. Take the total number of counts from the 20 readings.. Divide the total by 20 to obtain the average or mean value for the 20 readings and record this number. Take the square root of the average value to obtain the standard deviation and record this value.

mean(m) = total/20 = \_\_\_\_\_

standard deviation ( $\sigma$ ) =  $\sqrt{m}$  = \_\_\_\_\_

6. Compare below the distribution of the counts about the mean value with the probability distribution of Table II.

Range	Numerical Range	Number of Measurements in the Range	Function of Total Counts
0 to m-3 $\sigma$	_____ to _____	_____	_____
m-3 $\sigma$ to m-2 $\sigma$	_____ to _____	_____	_____
m-2 $\sigma$ to m- $\sigma$	_____ to _____	_____	_____
m- $\sigma$ to m	_____ to _____	_____	_____
m to m+ $\sigma$	_____ to _____	_____	_____
m+ $\sigma$ to m+2 $\sigma$	_____ to _____	_____	_____
m+2 $\sigma$ to m+3 $\sigma$	_____ to _____	_____	_____
m+3 $\sigma$ and larger	_____ to _____	_____	_____

NOTE: The fluctuations in background you observe may not follow the binomial distribution too well.

Question: Which of the factors listed below could cause a deviation from the binomial distribution?

	Can cause a deviation:	
	yes	no
Counts per measurement less than 100.	_____	_____
Small number of measurements.	_____	_____
Radionuclides in your body	_____	_____
Radionuclides in walls and floor.	_____	_____
Radionuclides in the air.	_____	_____
Cosmic radiation.	_____	_____

Part 2. The Measurement of the Ratio of Radiation From a Source.

1. Position your strontium-90 source beneath your detector at a distance such that you record a count of about 1,000 counts in thirty seconds.
2. Take and record below 20 measurements and determine the total, the mean and the standard deviation.

Measured  
Number

1

2

3

4

5

6

7

8

9

10

11

12

13

14

15

16

17

18

19

20

\_\_\_\_\_ Total

(m) \_\_\_\_\_ Mean

( $\sigma$ ) \_\_\_\_\_ Standard deviation

3. Compare the distribution of the counts about the mean value with the probability distribution of Table II.

<u>Range</u>	<u>Numerical Range</u>	<u>Number of Measurement in Range</u>	<u>Fraction of Total in Range</u>
0 to $m-3\sigma$	_____ to _____	_____	_____
$m-3\sigma$ to $m-2\sigma$	_____ to _____	_____	_____
$m-2\sigma$ to $m-\sigma$	_____ to _____	_____	_____
$m-\sigma$ to $m$	_____ to _____	_____	_____
$m$ to $m+\sigma$	_____ to _____	_____	_____
$m+\sigma$ to $m+2\sigma$	_____ to _____	_____	_____
$m+2\sigma$ to $m+3\sigma$	_____ to _____	_____	_____
$m+3\sigma$ and larger	_____ to _____	_____	_____

Question: Which set of measurements more closely approximates the binomial distribution, the background measurements or the source measurements?

4. The mean activity obtained in step 2 above contains counts from both the source and background. Let us call this term  $m_{Sb}$ . To obtain the mean activity from the source alone,  $M_S$ , we must subtract out the mean value of the background  $M_b$  obtained in step 4 part 1 as follows:

$$M_S = M_{Sb} - M_b$$

Calculate your mean count,  $M_S =$  \_\_\_\_\_

5. Based on the law of counting statistics, we can also calculate the standard deviation of the source alone ( $\sigma$ ) as follows:

$$\sigma_S = \sqrt{\sigma_{Sb}^2 + \sigma_b^2} = \sqrt{M_{Sb} + M_b}$$

where

$\sigma_{Sb}$  = the standard deviation of the source and background from step 2 part 2.

$\sigma_b$  = the standard deviation of background from step 4 part 1.

Calculate the standard deviation of the mean count,  $\sigma_S =$  \_\_\_\_\_

Question: Is the standard deviation of the source alone larger than  $\sigma_{Sb}$ ? Why?

## Chapter 4

### RADIATION HEALTH EFFECTS

#### RADIATION EFFECTS STUDIES

Of all the factors that do damage to our bodies, none has been as extensively studied as radiation effects. Since 1947, many millions have been spent on a long range study of nearly 100,000 survivors and their off-springs of the Hiroshima and Nagasaki bombings. Other extensive studies have been made on individuals receiving low level medical exposures and occupational exposures. Extensive tissue and animal radiation studies have also been conducted. There are a variety of prestigious national and international scientific organizations who continually review the scientific findings in this area.

#### Factors Which Influence Radiation Effects

Radiation effects are not dependent solely on the amount of radiation received. Other factors must be considered.

The rate at which a radiation dose is received is an important factor in determining its effect. This is because living tissue is not inert. As soon as damage is produced, healing begins. Thus, if a particular dose is delivered over a long period, it is possible that repair may keep up with the damage, so that no detectable change would be produced. On the other hand, if the same dose is delivered all at once, the change may be noticeable.

Knowledge of the effects of radiation has generally resulted from data on large doses received in a short time. Data sources include Hiroshima survivors, victims of radiation accidents and patients receiving radiation therapy. However, most humans are exposed to low doses and low dose rates. To see the biological effects of this type of radiation, one would have to observe large groups of people over many generations. Because of this difficulty, the general practice is to predict the results of the low doses and low dose rates on the basis of high dose and high dose rate data.

Furthermore, in order to be conservative in estimating radiation effects, one must assume that some injury results from any exposure to radiation. Accord-

ing to the International Committee on Radiation Protection (ICRP): "The objectives of radiation protection are to prevent acute radiation effects, and to limit the risks of late effects to an acceptable level. For purposes of radiation protection, any exposure is assumed to entail a risk of biological damage." It should be stressed that this is not known to be the case. There are certainly levels of radiation that produce no detectable effects--background radiation and routine diagnostic X-rays, for example. But the most conservative assumptions are used to insure maximum protection for the population.

The age of the exposed individual can greatly affect his/her sensitivity to radiation. When organs are developing before birth, sensitivity is high, because differentiating cells and cells undergoing rapid division are more easily damaged. Similarly, from birth to maturity, high rates of cell division and possible further differentiation make a child more sensitive to radiation exposure. An adult is more resistant to radiation effects. Exposure, however, may give rise to genetic effects in the exposed adult's future children. For a person beyond the reproductive age, genetic effects are not important. Similarly, radiation effects which might appear only after a long time (for example, tumor induction) would not be as significant to older people as to younger people.

Some parts of the body are more sensitive to radiation effects than other parts. For example, if the upper abdomen is irradiated, the radiation effects are more severe than if a body area of similar size elsewhere were exposed to the same dose. This is because of the presence of vital organs in the upper abdominal area. Thus the relatively high doses from sources such as dental x-rays can be tolerated since they are confined to an extremely small area containing no vital body organs.

Irradiation of a small part of the body surface will have much less general

effect than an equal dose delivered to the whole body, since the unirradiated portions can help the affected portions recover.

The whole body can receive a radiation dose from radioactive materials taken into the body. The most common sources of significant levels of radioactive materials inside the body are nuclear medical techniques. Radioactive materials move through the body in the same manner as nonradioactive materials. They are also eliminated in the same manner and constantly become weaker through radioactive decay.

Although it is possible to determine an average dose of radiation which produces certain effects, individual responses will vary from the average. For instance, a dose of about 600 rads in a single exposure killed half of a group of rats within 30 days. On the other hand, some rats died after 400 rads and some lived after 800 rads.

#### Biological Effects of Radiation

Biological effects of radiation are divided into two general classes. Somatic effects are those observed only in the person who has been irradiated. Genetic effects are those seen in the offspring of the person irradiated.

Somatic effects originate with the response of the irradiated cells. The first event in the absorption of ionizing radiation is the production of excited atoms and ion pairs. When these are produced in the chemical systems of a cell, new and possibly harmful chemicals are produced as the original chemical structure of the cell is disturbed by the radiation. Thus toxic materials may be produced. Furthermore, if the radiation affects chromosomal material within the cell nucleus, cell division may be affected. Thus, a cell may respond to irradiation in several ways: chromosomal changes, cell death before division, failure to specialize, failure to divide completely, or slowing its division rate. Some cells will be unaffected by the radiation.

The cellular response to radiation is determined by a number of factors. Among these are the cell's stage of specialization, its activity, and its division rate. These factors partially account for an embryo's great sensitivity to radiation. In the embryo, a small group of cells will eventually specialize or form an organ, so these cells are especially radiosensitive.

These factors also help to make radiation therapy possible. A patient with cancer, for example, receives a number of exposures, giving him/her a large total radiation dose. Through the phenomenon of repair following radiation exposure, the cells begin to repair the radiation damage between exposures. However, the rapidly dividing cancer cells have a greater chance of being destroyed by the radiation because they are more frequently in the radiosensitive stages of cell division.

The radiosensitivity of organs and tissues depends on cell multiplication. In the lining of the gastrointestinal tract, for example, some cells are mature. These are continuously being discarded and replaced by new cells produced nearby. If a high dose of radioactivity is received, these rapidly dividing cells will be severely decreased in number. If the dose is not too high, the surviving cells will be able to replace those destroyed.

If a large dose is given to a small area of the body, the general and local effects depend on which organ is irradiated. For instance, a large radiation dose to an arm will very likely cause detectable changes in the arm. But it will not result in death or severely damage the blood-making system, because the majority of this system was not exposed to the radiation. On the other hand, a moderate dose to the reproductive organs can result in temporary sterility.

A large, sudden, whole-body dose of radiation produces the acute radiation sickness syndrome: nausea, vomiting, general aches and pains, and possibly a decrease in the number of white cells. Localized phenomena, such as reddened

skin or loss of hair, may be produced. Larger doses cause weakness, drastic depression of all blood elements, and possibly sterility. At still higher doses, death will probably occur.

It has been shown in animals that high radiation doses cause the body changes that occur with aging. It is obviously difficult to obtain such data for humans, but it is probable that some degree of life-shortening may occur following high dose exposures.

Identifying the effects of low levels of radiation is difficult because no new type of malady is produced. Instead, there is at most an increased frequency of disorders which are also produced by other environmental factors or which occur spontaneously with no known cause. For example, cancer and leukemia may be long-delayed consequences of a single large exposure to radiation, and they may also follow chronic exposure. But they are by no means an inevitable result of any form of human exposure to radiation.

A recent report by the National Academy of Sciences Committee on the Biological Effects of Ionizing Radiation (BEIR) estimates that it will take a population dose of 7,000 person rem to produce between one to five excess fatal cancers.

Genetic effects refer to the production of mutations, which are permanent, transmissible changes in the characteristics of an offspring from those of its parents.

Mutations occur in all living organisms. They may occur of their own accord, apart from any known alteration in the environment. Whatever their origin, most mutations are undesirable. Every individual has some of these undesirable mutations.

Radiation-induced mutations are divided into two classes: gene mutations and chromosomal abnormalities. Most radiation-induced alterations are gene mutations, which tend to be recessive. In other words, the effect of the



mutation is not seen in the offspring unless the altered gene is carried by both parents. Even though the mutation may not be seen in first-generation offspring, it makes such offspring slightly less fit.

Chromosomal abnormalities include chromosome loss and chromosome breaks. These effects are severe, the result usually being the death of the embryo before birth. This type of genetic effect happens much less frequently than does gene mutation.

The increase in genetic damage to be expected from radiation is sometimes discussed in terms of doubling dose. This dose would eventually cause a doubling in the rate of gene mutations that occur spontaneously.

In the United States, about 100 million children are born in a generation. Of these, about two per cent will have detectable genetic defects as a consequence of spontaneous, unavoidable genetic changes passed on by all their ancestors. If a doubling dose of radiation were applied to present and future generations, it would eventually lead to a gene mutation rate of four per cent. It would take on the order of 10 generations to reach the four per cent rate. The doubling dose cited by the National Academy of Sciences report, "The Effects on Population of Exposure to Low Levels of Ionizing Radiations, is estimated to be 40 rads (40,000 mrad) per generation." In other words, if the average dose to the reproductive cells of all of the individuals of the population were a total of 40 rads from conception to age 30, or 1.3 rads per year above background for every generation, after about 10 generations the rate of impairing mutations would gradually increase so as to eventually double from two per cent to four per cent. This amount of radiation is far above that obtained from any current man-made source.

The recent BIER report estimates that it will take on the average of about 100,000 person rem to produce each socially significant genetic effect.

It should be pointed out that only between five and 12 per cent of all genetic changes are caused by environmental radiation. The majority of genetic changes are produced by other causes, including environmental pollutants.

#### Nonhuman Biological Effects

In nature, hundreds of thousands of species of plants and animals have been identified. It is reasonable to expect that a wide range of sensitivities to radiation would be seen in this great variety. While radiation protection guides are written for the protection of humans, much of the data upon which such guides are based was derived from animal experiments.

The basic conditions that tend to predict radiosensitivity in humans, such as cell division rate and age, apply to all other life forms. However, there is a wide range of variation among species. The more complex the organism, the more sensitive it is to radiation effects.

A number of types of organisms have been known to reconcentrate radioactive materials in their bodies. An example is shellfish such as oysters and clams. These organisms can reconcentrate certain radionuclides up to 100,000 times the levels found in the water in which they live. This reconcentration does not appear to affect the well-being of the animal, but people who use these shellfish as a major source of food could receive a significant fraction of their maximum permissible dose in the process. For this reason, edible shellfish living near nuclear plants are used as monitors for crosschecking radioactive discharges.

#### Effects of Low Level Radiation

What are the risks from small amounts of radiation? The latest National Academy of Sciences study indicates, according to its chairman, "At Low doses the risks are very small. There is a risk, but it's not the end of the world."

Another member of the study panel disagrees somewhat: "We have no idea what the effects are from very low levels, and in any case they are undetectable."

This very fact of being unable to clearly detect any effect, accompanied by an unwillingness to say that there is no effect at all, has led into a dilemma. In order to avoid setting standards which would expose the public to unnecessary radiation, the National Council on Radiation Protection and Measurements has recommended exposure limits based upon the following very cautious assumptions: (1) There is a single, linear dose-effect relationship for the effects of radiation, from zero dose with no effect to the known effects of high level doses. (2) There is no threshold of radiation below which there is no effect. (3) All doses received by an individual are additive—that is, their effects add up. (4) There is no biological recovery from the effects of radiation. Much of the available evidence indicates that several of these assumptions are conservative, but in the interest of safety, it is assumed that they are true, under the philosophy that it is better to be oversafe than to be sorry at some future date.

The radiation protection guide, arrived at as a result of these assumptions, gives a maximum permissible dose to the general population. The maximum is presently 500 mrem/year above natural background. This figure does not include an individual's radiation dose from medical procedures. The NCRP does not attempt to regulate or limit radiation exposure for necessary diagnostic and therapeutic purposes, but it does recommend reductions in any exposure which does not contribute to treatment or diagnosis.

People are becoming more cautious about having x-rays that might not be needed. In all cases, doctor and patient must decide when benefits outweigh risks. This is particularly true with the large doses received in radiation treatment for cancer. Doctors know that such doses increase the risk of a

second cancer, but they also may lengthen the life of the patient.

The radiation dose limit for radiation workers is 5000 mrem per year, 10 times that for the general public. There have been suggestions that this maximum exposure level should be reduced, perhaps by a factor of 10. Part of the controversy over this subject stems from a study done by Dr. Thomas Manusco of workers at the government nuclear facilities at Hanford, Washington. He studied the causes of death of people who had received radiation exposures while working at Hanford, and concluded that some of the cancer deaths could be correlated with low-level radiation exposures. Other scientists, questioning Dr. Manusco's methods of analyzing the data on the deaths, have concluded that there is no evidence of an increased death rate from cancer or any other cause in the Hanford workers.

## Chapter 5

### NUCLEAR REACTORS

#### INTRODUCTION

It happened on December 2, 1932, beneath the west stands of Stagg Field in Chicago. A group of scientists, led by Nobel Prize winner Enrico Fermi, first initiated and controlled a self-sustaining nuclear chain reaction. From that pile (and it was actually called an atomic pile) of graphite, wooden timbers, and uranium was born a significant energy resource that in 1978 supplied over 4 percent of the United States' total energy demand and about 13 percent of our nation's electrical needs.

As the name implies, nuclear energy comes from the energy contained within the nucleus of the atom, rather than the energy of the electrons as in chemical reactions such as the burning of coal. The energy released in nuclear reactions can be over 100 million times greater per atom than the energy released in a chemical reaction. Although there are many different kinds of nuclear reactions, present-day nuclear reactors rely on one specific nuclear reaction—fission.

#### THE FISSION PROCESS

Today, the explanation seems obvious; but in 1938 to German radiochemists O. Hahn and F. Strassman, the results of their experiments were perplexing. When uranium was bombarded with neutrons, they concluded that one of the elements produced was barium, an atom with nearly half the mass of uranium. It was Lise Meitner and her nephew O. R. Frisch who suggested the correct interpretation of the results. In a letter dated January 16, 1939, published in the English scientific magazine Nature, Meitner and Frisch wrote, "It seems possible

that the uranium nucleus has only small stability of form and may, after neutron capture, divide itself into two nuclei of roughly equal size." Similar experiments had been conducted by Enrico Fermi earlier, but they were not correctly interpreted. American biologist William Archibald Arnold suggested that this splitting of the uranium nucleus into two halves be called fission, the term used for the dividing of living cells.

Thus, it was determined that when the atoms of certain heavy nuclides are bombarded by neutrons, some of the nuclei of these atoms will capture a neutron and become unstable. As a result of this instability, the atom splits or fissions into two smaller atoms. Together the fission products weigh slightly less than the original atom and the bombarding neutron combined; this fission mass is converted to energy, as described by Einstein's formula: energy equals mass times the velocity of light squared ( $E = mc^2$ ). It is this conversion of mass into energy that makes nuclear energy so powerful and sets it apart from ordinary chemical reactions, where no such conversion occurs. As fission fragments fly apart, most of this energy appears almost instantaneously as heat as the fragments lose their energy of motion to the surrounding material. The heat from this fission reaction can then be used to boil water to make steam, which in turn spins turbines that generate electricity.

Uranium-235 is the only atom found in nature that readily undergoes fission by neutron bombardment. (Plutonium-239 and uranium-233 also undergo fission by this process but are considered man-made elements.)

If the splitting of the uranium atoms were the only thing that happened in the fission process, it would probably be nothing more than a scientific curiosity. But a very important consequence of the fission of uranium-235 is that it is accompanied by the release of free neutrons which can interact with other uranium atoms, causing more fissions and producing more free neutrons,

resulting in further fissions and so on. This series of fissions followed by more fissions is referred to as a chain reaction (Figure 12). If a chain reaction is to continue, there must be enough fissionable atoms packed sufficiently close to insure the capture of enough neutrons to keep the rate of fission constant. The amount of material required for this is called the critical mass.

Generally, the smaller atoms produced by fission are radioactive. These fission fragments usually decay by negatron emission followed by gamma ray emission. Figure 13 shows one of more than 30 possible chains of decay following the fissioning of an atom of uranium-235. The fission fragments are atoms of radioactive bromine-90 and xenon-143, and they each decay through many steps by emitting beta particles. The half life for each part of the chain is shown in Figure 13. Note the diversity of half life lengths. Other possible decay chains produce fission products which have half lives of hundreds or thousands of years.

#### NUCLEAR REACTORS

To harness the energy produced in the fission process, a suitable environment must be maintained in which fission reactions can be initiated, sustained, and controlled, and the nuclear energy can be converted into a useful, transportable kind of energy. A commercial nuclear reactor provides these things. There are certain components that are common to all nuclear reactors regardless of their specific design. These are fuel, coolant, control rods, moderator, and shielding.

The uranium fuel, usually in the form of ceramic pellets of uranium dioxide, is contained within fuel rods in the reactor core, which is the heart of the reactor. A typical reactor core contains thousands of fuel rods which in turn contain several million uranium pellets.

# NUCLEAR FISSION CHAIN REACTION

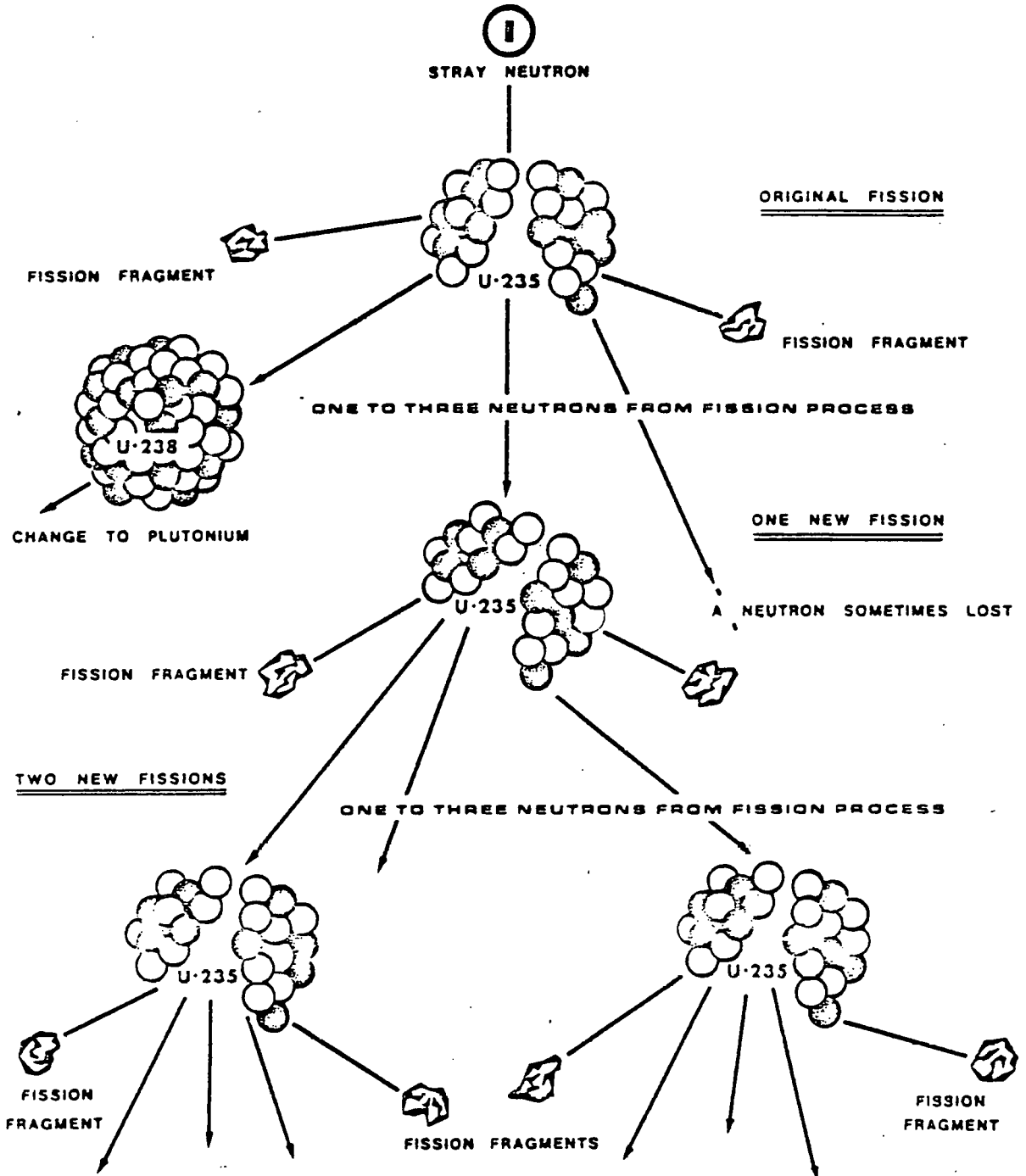
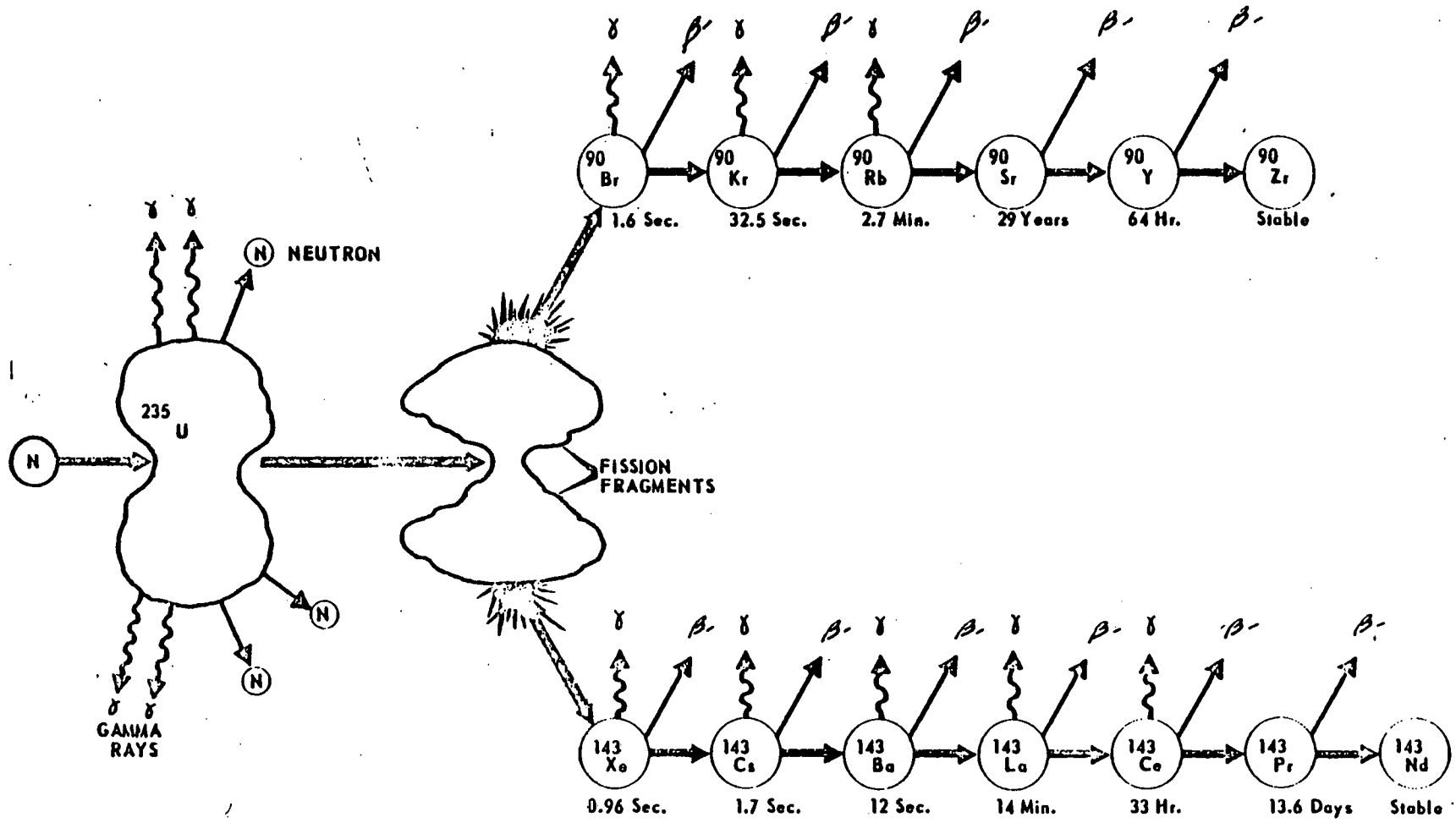

FIGURE 12





URANIUM FISSION AND BETA DECAY CHAINS

FIGURE 13

The uranium fuel must undergo several preliminary processes before it is used in a reactor. After uranium is mined, it must first be processed to produce uranium oxide, known as yellowcake. Then it is converted to uranium hexafluoride, a gaseous form essential in the next step, the enrichment process. The natural concentration of uranium-235 in uranium is only seven-tenths of one percent. The rest of the uranium is non-fissionable uranium-238. In order for uranium to be used as a fuel for power plants, the concentration of uranium-235 must be raised to about three percent. This fuel is then said to be enriched in uranium-235. The federal government is currently the only provider of enrichment services in the United States. Its three gaseous diffusion enrichment plants provide the enriched uranium for all reactors in the United States as well as for many foreign reactors. Power companies and other users pay the government for these services. After enrichment, the uranium hexafluoride is converted to uranium dioxide, which is then fabricated into fuel rods.

The coolant, either a liquid or gas, flows over the fuel rods and removes heat from the fuel. Since the fuel is contained within the fuel rods, the coolant does not come in direct contact with the fuel. The coolant then is either converted directly to steam or goes through a heat exchanger to convert water into steam. This steam drives a turbine which turns a generator to produce electricity.

Water is used as the coolant in all except one reactor in the United States (a gas cooled reactor). Thousands of tons of water circulate around the core to carry away the heat. The core and cooling water are both contained in a heavy steel pressure vessel which is in turn shielded by a steel-lined concrete containment structure.

For safety and reliability, there must be some way to control the nuclear reaction - to speed it up, slow it down, or stop it entirely. One way would be

to move fuel out of the core until not enough remained to sustain a chain reaction. But this would be a rather cumbersome, unsafe, and time-consuming process. Another way of controlling the reaction would be to somehow stop some or all of the neutrons that are produced in the fission process from interacting with the uranium-235. This can be achieved by the use of control rods, which act as neutron sponges. The control rods, made of materials such as boron that readily absorb neutrons, are positioned inside the fuel assembly. If the rods are pulled out of the assembly, more neutrons are available to cause fissioning of the fuel, so the rate of reaction increases. If the rods are inserted into the fuel assembly, they absorb neutrons, so that there are fewer neutrons available to the fuel. Thus, the chain reaction slows or even stops completely. This makes it possible to produce heat at a desired rate, or to shut down the reactor.

The moderator, a material within the reactor core, is used to slow down neutrons as they emerge from the fissioning atoms. Slowing is necessary because neutrons traveling too fast are less readily captured by the uranium-235, and they must be captured in order to cause fission. A moderator may cause a decrease in speed of nearly ten thousand times, but even a slow neutron travels at a rate of appreciably more than a mile per second. Graphite, water, or heavy water can be used as moderators. Except for the one gas-cooled reactor, which uses graphite, U.S. power reactors use the cooling water as the moderator.

As a by-product of the fission process, several different kinds of radiation are produced. Shielding, consisting of various materials surrounding different portions of the reactor systems, prevents this radiation from escaping into the environment.

## TYPES OF REACTORS

At the end of December 1978, 72 nuclear power reactors were authorized to operate, producing 52,296 megawatts of electricity. Construction permits had been issued for 92 additional reactors at 51 sites, and meaningful construction had begun for all but four units. Thirty additional reactors were in some phase of planning prior to construction.

The most common type of reactor in the U.S. is the light water reactor, including the boiling water reactor and the pressurized water reactor. (Light water is ordinary water,  $H_2O$ , as distinguished from heavy water containing the hydrogen isotope deuterium.) There is one high temperature gas cooled reactor in operation in Colorado. About two-thirds of the operating and planned reactors are pressurized water reactors. Most of the rest are boiling water reactors. Figure 14 shows the location of power reactor sites in the United States.

### Boiling Water Reactors (BWR)

In the boiling water reactor (Figure 15), water is brought into the reactor and allowed to boil. It is then expelled from the reactor vessel as saturated steam, which drives the turbine.

Typically, a BWR operates at a pressure of about 1,000 pounds per square inch and produces steam at about 550 degrees Fahrenheit. The BWR has the advantage of simplicity and the disadvantage of requiring a large core for cooling. Some of the materials in the water may become radioactive and be carried through to the turbine section, increasing the size of the area where radiation exists.

### Pressurized Water Reactors (PWR)

In a pressurized water reactor (Figure 16), pressure keeps the water from boiling. Instead, water is pumped through the core and removed at the top as

# Central station nuclear power plants in the United States

as of June 30, 1978

Source: AIF

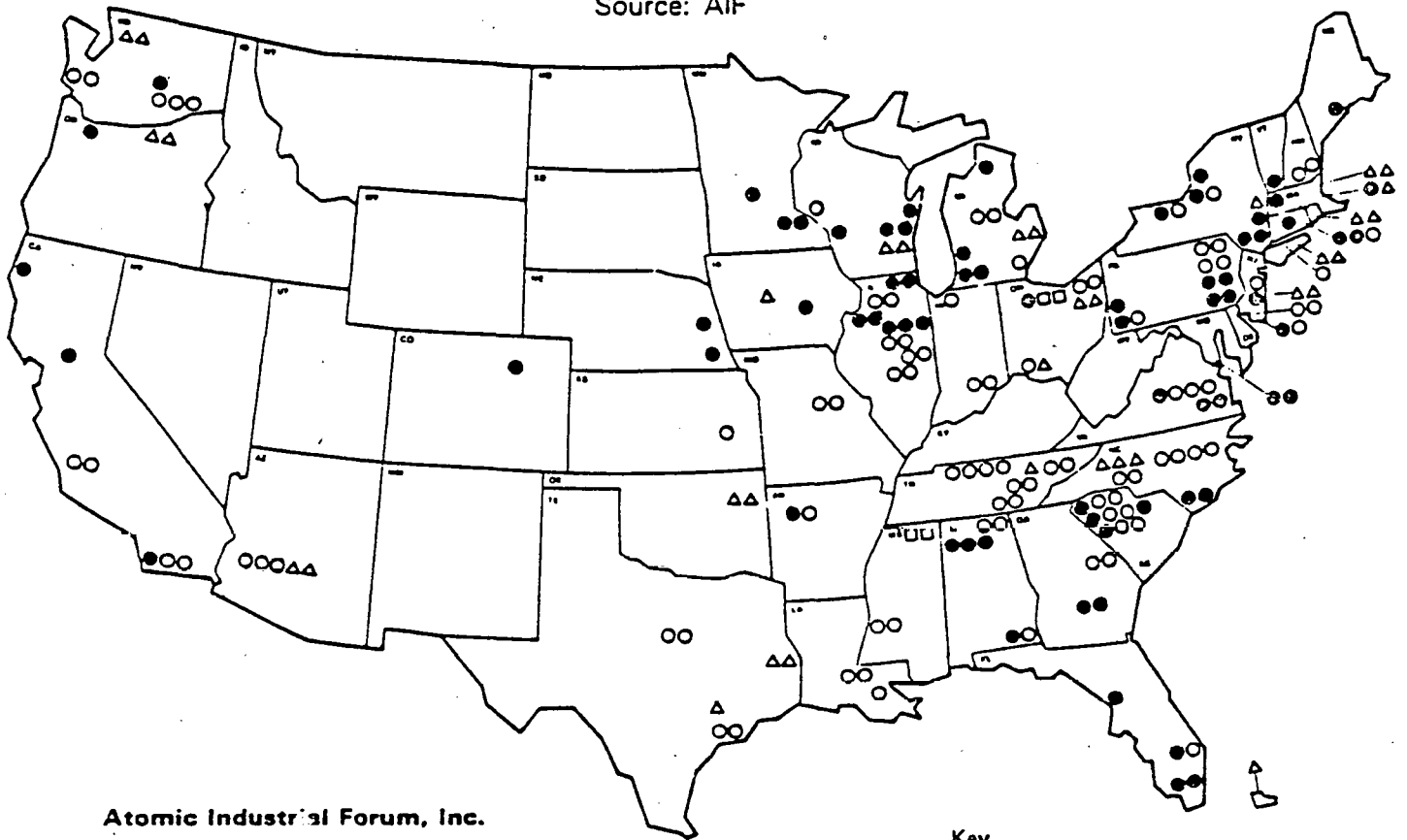

Atomic Industrial Forum, Inc.

FIGURE 14

- Key
- Operable
  - Under Construction
  - Limited Work Authorizations
  - △ On Order

# Boiling water reactor (BWR)

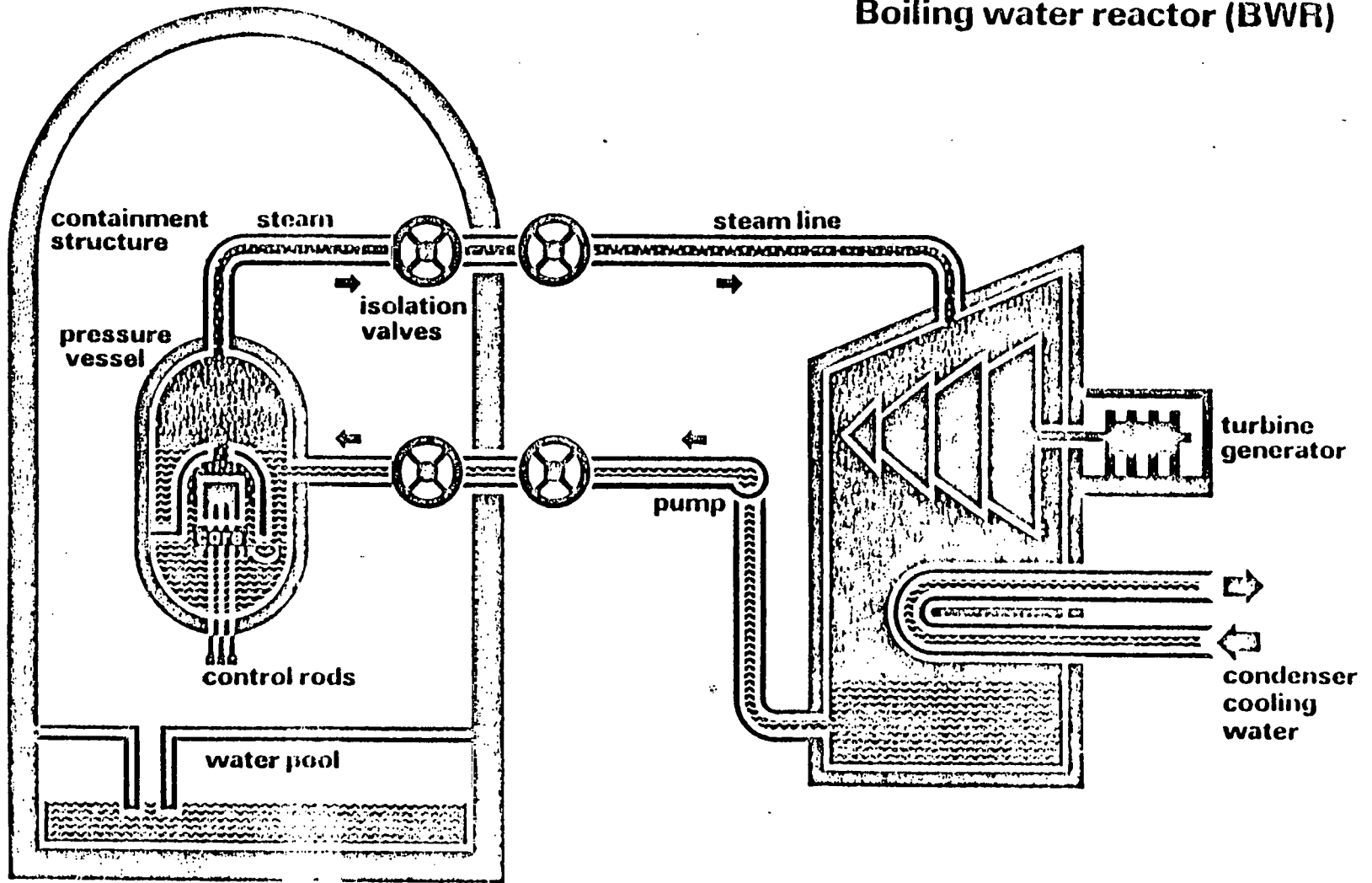

123

FIGURE 15

# Pressurized water reactor (PWR)

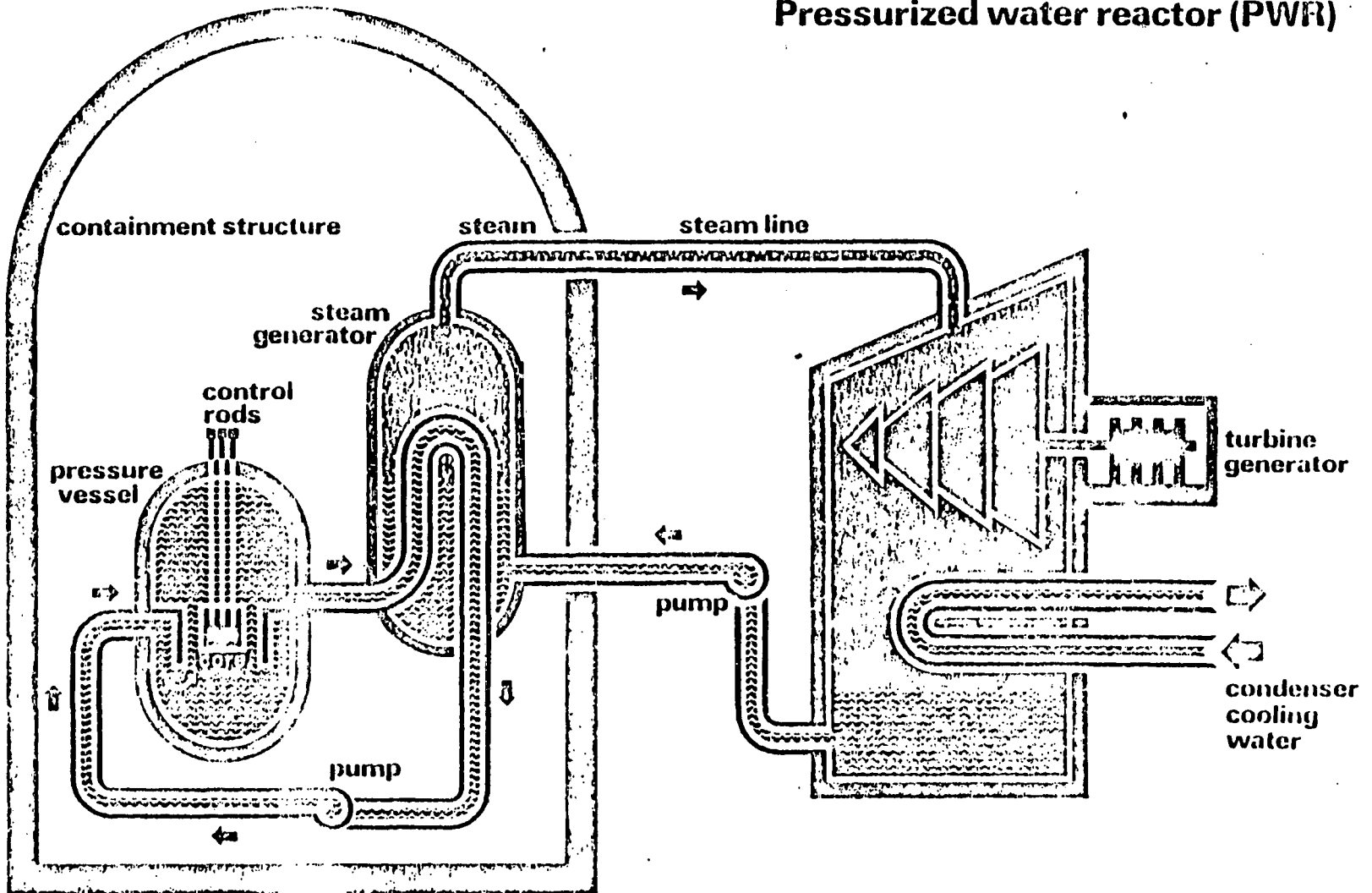

124

FIGURE 16

a heated liquid. The water is then circulated through a heat exchanger, where steam is produced from water in a secondary loop. The steam drives the turbine. The cooled water in the primary loop is returned to the reactor to again cool the core.

The PWR primary loop normally operates at a pressure of 2,000 pounds per square inch and at an average temperature of 590 degrees Fahrenheit. The coolant in the PWR core does not directly contact the turbine, so the turbine area remains uncontaminated with radioactive materials. The higher pressure allows more efficient heat transfer and requires a smaller surface area for the core. The PWR, however, requires higher operating pressures and additional heat exchangers which lower its efficiency.

#### High-Temperature, Gas-Cooled Reactors (HTGR)

In the high-temperature, gas-cooled reactor (Figure 17), the core is cooled by certain gases passing over it, usually purified carbon dioxide or helium. The gas coolant gives up its heat to water circulating through a steam generator. The moderator system usually consists of graphite blocks pierced to contain the fuel. This type of reactor has a low fuel consumption rate. Also, since the gas coolant can be heated to much higher temperatures than water coolant, it can produce steam at higher temperatures than water-cooled reactors. The high temperature allows the use of the best turbine technology and reduces the release of waste heat. But the gas circulation system requires very large blowers, and the core must also be large in order to have enough surface area for effective cooling.

#### SAFETY SYSTEMS IN NUCLEAR REACTORS

Stringent safety precautions must always be taken by the builders of nuclear plants, which cannot be built or operated without a license from the Nuclear Regulatory Commission, charged by law with the responsibility of



# High temperature gas-cooled reactor (HTGR)

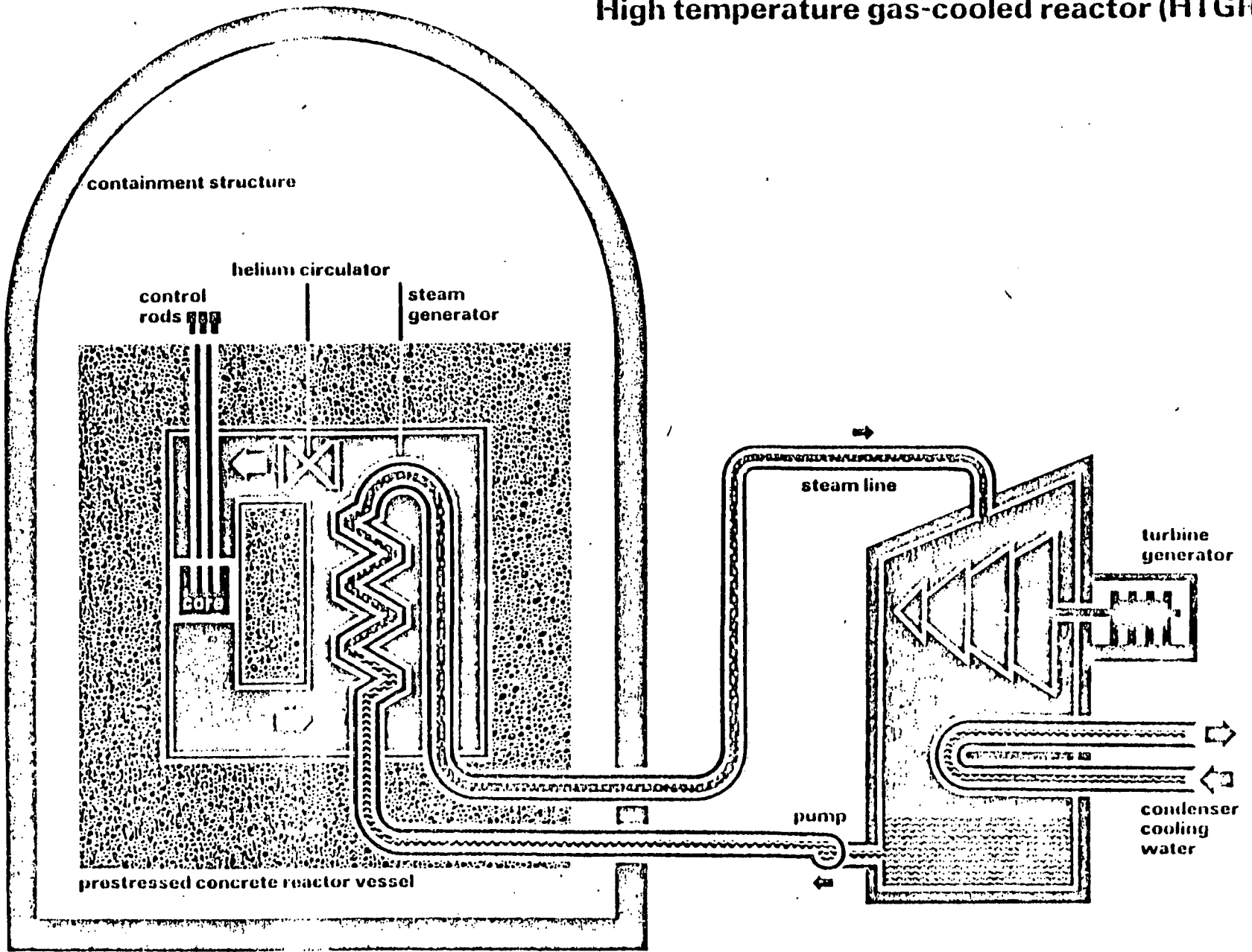

126

FIGURE 17

satisfying itself that the plant will not endanger public health and safety. Licensing was previously done by the Atomic Energy Commission (AEC), which was abolished in 1974. The AEC's research and development activities were taken over by the Energy Research and Development Administration (ERDA), now part of the Department of Energy (DOE). The regulatory and licensing activities are the function of the Nuclear Regulatory Commission (NRC).

#### Control During Normal Operations

Nuclear power plants form small quantities (several pounds per day) of radioactive substances. In normal operation, more than 99.99 percent of these substances stay within the fuel assemblies. The small amount that escapes from the fuel enters the reactor coolant system, where almost all of it is removed by purification equipment. An extremely small amount of radioactivity is released to the environment under strict control, subject to conservative and rigidly enforced health and safety regulations.

#### Natural Safeguards

In today's water-moderated power reactors, if the rate of fissions were to increase significantly, more heat would be produced. The heat would increase the energy of the neutrons in the fuel, and thus, increase the proportion of neutrons escaping from the core and being captured by non-fissioning atoms. The rate of fission would thus slow down. This effect is automatic and instantaneous, and is one reason why a nuclear reactor cannot possibly become a bomb. In a bomb, essentially pure fissionable material is required, much more than in the slightly enriched reactor fuel, and it must be rapidly compressed and held together for the chain reaction to increase to an intensity of a nuclear explosion.

The use of water as a coolant and moderator provides another safety feature. If the reactor were to exceed its designed power level, it would raise the temperature of the water, which would in turn decrease the water's ability to act as a moderator. This tends to reduce the reactor's power level.

### Engineered Safeguards

In addition to natural safeguards, many safety features are built as an integral part of any reactor facility.

One such safeguard is a monitoring system for neutron intensity. Neutrons initiate the fission reaction, and the number of available neutrons is related to the reactor power level. Thus, measurements of the number of available neutrons are made by several independent monitoring systems at various locations in the reactor core. These instruments are connected to a rapid shutdown system in case neutron intensity rises above a pre-set limit.

Reactor control systems are also designed for safety. Materials such as boron or cadmium are able to absorb neutrons, and by removing neutrons from the system, shut down a reactor, preventing new fissions from occurring. Common methods of using these control systems include the mechanical insertion of control rods into the core and the addition of liquid solutions of these neutron-absorbing elements to the water moderator. Most water reactors have both methods of control available.

Instruments constantly monitor what is happening in the core. Improper signals concerning temperature, pressure, or other unwanted conditions will immediately shut down the reactor. Each safety system has one or more backup systems in case there is a failure in the primary system.

Reactor designers assume that at some time, electric power to a nuclear plant may be shut off. To allow for this possibility, they usually design reactor systems that require no electric power to achieve safe shutdown. Those which may require power after shutdown, such as those which keep the coolant circulating, are equipped with emergency diesel generators and batteries so that they can operate when no outside power is available.

Although the nuclear chain reaction can be stopped immediately, radioactive fission products in the fuel rods continue to decay and give off heat. If for some reason there is a rapid loss of the coolant water to a nuclear reactor, it is conceivable that the core might melt due to heat from these fission products. This core meltdown could result in dangerous releases of radioactive material. In order to prevent the core from overheating due to a loss of coolant, several independent emergency core cooling systems are available to bring in water to cool the core. The network does not require an operator to get started.

In order to test the effectiveness of emergency core cooling systems, the Nuclear Regulatory Commission built a loss-of-fluid test (LOFT) reactor in Idaho. In December 1978, this reactor had a planned loss of coolant accident, allowing the effectiveness of the emergency core cooling systems to be observed. The results of this experiment indicated that the systems of an actual nuclear reactor will work even better than expected. Reactor temperatures never rose as high as predicted, nor did it take as long as expected for emergency cooling water to cool the radioactive core.

#### Containment in the Event of an Accident

There are many barriers in reactor systems to guard against radioactive substances escaping to the environment. There is, first of all, the ability of the fuel material to retain most of the fission products, even when overheated.

Then there is the fuel element cladding, through which fission products must pass to get into the reactor coolant. Next, there are the walls of the reactor vessel itself. Finally, there is the containment system, constructed to halt any release of radioactive material that gets past all the other barriers. The reactor building itself may be sealed off as a secondary containment system.

### Assessments of Nuclear Safety

Several attempts have been made to determine the probability of a serious nuclear accident. One of the best known, WASH-1400, also called the Rasmussen report, was ordered in 1972 by the Atomic Energy Commission. They determined that the worst credible accident would kill 3,300 people and cause radiation injuries to another 45,000. Several thousand square miles of land would be contaminated and 290 square miles would be uninhabitable for a year or more. The probability that such an accident would occur was calculated to be extremely small--if there were 1,000 reactors in operation, such accidents would be a million years apart.

The Union of Concerned Scientists has produced a critique of WASH-1400. They believe that under the worst possible conditions, the immediate and eventual deaths from a nuclear accident might exceed 300,000, and such accidents have the probability of occurring about once every 50,000 years.

The NRC recently commissioned a group to review the Rasmussen study. Their findings, the Lewis Report, state that much of the data needed for calculations of reactor risks is still inadequate and that WASH-1400 cannot be used to prove the safety of nuclear power. The authors were unable to say whether reactors are more safe or less safe than the figures in WASH-1400 suggest.

Nuclear power opponents argue that the consequences of an accident would be so catastrophic that any risk, no matter how small, is unacceptable. They contend that the accident at Three Mile Island, caused apparently by a combination of human errors and equipment failure, shows that no matter how many safeguards there are in a system so complex it is impossible to anticipate and provide for all the things that can go wrong. The Three Mile Island accident will be discussed later in this chapter.

#### THE PRICE-ANDERSON ACT

When nuclear power began to emerge in the U.S., Congress was concerned with providing protection to the public and limiting the liability of the nuclear industry in the event of a major nuclear accident. To accomplish these purposes, The Price-Anderson Act was enacted in 1957 and renewed for the second time in 1976.

Price-Anderson is not unique in providing government liability protection. The federal government also provides deposit insurance for bank accounts, flood insurance, and disaster aid.

At present, a total of \$560 million is available to cover liability claims for a nuclear accident at a licensed power plant or reprocessing facility or during the normal course of transportation between such facilities. The act requires that a maximum amount of insurance be first purchased from a private source. This amount is currently set at \$390 million by the American Nuclear Insurers. The federal government provides the rest of the insurance, up to the maximum of \$560 million. Each utility pays a premium to the government for Price-Anderson coverage.

The Price-Anderson Act will be in effect until August 1987. The entire responsibility for providing the \$560 million liability protection, which

includes both personal injury and property damage, will be gradually transferred to the utilities. Congress has also guaranteed further action if the liability exceeds \$560 million.

## WASTES FROM NUCLEAR POWER PLANTS

### Heat as a Waste Product

Heat is not normally thought of as a waste product, but it is put into the environment in large amounts by both nuclear and fossil-fueled power plants. Most of the energy used by humans is produced by the conversion of heat energy into other energy forms such as electrical or mechanical energy. The efficiency of this conversion is limited by natural laws. Thus, a large portion of the energy involved in the conversion is lost, usually in the form of heat. Modern steam turbine equipment provides relatively high thermal efficiency compared to other engines. The thermal efficiency of most electrical generating stations is slightly more than 30 percent. This means that almost 70 percent of the total available energy is not used and must be discarded into the environment as heat.

The problem of heat removal is greater for nuclear plants than for fossil-fueled plants. One reason is that nuclear plants discharge almost all their waste heat into their cooling water. Fossil-fueled plants, on the other hand, discharge about 15 percent of their waste heat directly into the air with the stack gas so that only about 85 percent must be removed by the water.

The thermal efficiency of most nuclear power plants is slightly lower than that of modern fossil-fueled plants. Using high temperatures (1,000 to 1,100 degrees Fahrenheit) and high steam pressures (1,800 to 3,500 pounds per square inch), modern fossil-fueled plants may attain a thermal efficiency of 37 to 40 percent. Because of their design, most nuclear plants produce steam

at lower temperatures (500 to 600 degrees Fahrenheit) and at lower pressures (800 to 1,000 pounds per square inch). Thus, their thermal efficiency is lower than that of the best fossil-fueled plants, averaging about 32 percent. Because of this lower efficiency, they must reject more heat.

As previously discussed, heat from the combustion of fossil fuels or from the fission of nuclear fuels is used to make steam in a generating station. The steam drives a turbine connected to an electrical generator. As the heat energy of the steam is converted to mechanical energy, the temperature and pressure of the steam decreases. This steam, called spent steam, is converted back to water in a condenser and returned to the boilers, where it is reconverted to high pressure steam for reuse in the cycle. The heat removed from the spent steam in order to condense it is the waste heat released to the environment.

Condensation is accomplished by passing large amounts of cooling water through the condenser. In the least costly method, the cooling water is taken directly from a nearby river, lake, or other large body of water. The cooling water is heated 10 to 30 degrees Fahrenheit, depending on plant design and operation, and then returned by cooling canals to its source. Usually, only a small fraction of the volume of a body of water is used for cooling water. Thus, the temperature change is usually less than one degree Fahrenheit at points 1,000 feet from the point of discharge of the heated water. The body of cooling water eventually loses the added heat to the atmosphere. This type of cooling system is called a once-through system. If the volume of the body of water is not sufficient, the heated water may be critically low in oxygen, therefore favoring the rapid growth of some aquatic plants. If the temperature change in the cooling water is excessive, it may create critical ecological problems. The use of once-through cooling is restricted in many



areas; and new installations of this type are permitted only if the volume of water allows only negligible temperature changes.

Other methods of cooling are more expensive, but they place less strain on natural waterways. Each has its own environmental effects and economic penalties so that the best system for a particular plant must be decided on a case-by-case basis in an attempt to gain the greatest environmental benefits at the least cost.

A cooling method which is finding favor in many areas is the use of wet or dry cooling towers. In such systems, water is drawn from a nearby source, passed through the condenser, and then through a cooling tower, where at least part of the waste heat is transferred to the air. The cooled water may then be returned to its source or be reused in the condenser.

In wet cooling towers, the cooling water is brought in direct contact with a flow of air, and the heat is dissipated primarily by evaporation. The flow of air through the cooling tower can be provided by either mechanical means or natural draft, and makeup water must be added to replace evaporative losses. Wet cooling towers for a 1,000 megawatt nuclear plant may evaporate up to 20 million gallons of water per day. This excess water burden in the atmosphere may affect local weather conditions. In cold or humid weather, the likelihood of fogging and precipitation increases, and in some cases in cold weather, moisture from these towers create icing problems on nearby plant structures and roads.

Dry cooling towers are similar to automobile radiators in that the heat dissipates by conduction and convection rather than evaporation. Dry cooling towers probably produce the least environmental effects of all cooling systems. However, they are much more costly because they require a larger surface area for heat transfer and the circulation of a larger volume of air. They also reduce the plant's efficiency.

In yet another method of cooling, artificial ponds or lakes are constructed to provide water for circulation through the condensers. A 1,000 megawatt plant might require as much as 3,000 acres for such a pond. These ponds create some local fogging on cold days as warm surface water evaporates.

Although these alternatives offer relief from potential thermal effects, they are not a satisfactory answer to the heat problem. The real answer is two-fold: finding a use for the excess heat and increasing the efficiency of electrical generation to decrease the amount of excess heat.

Research is underway on uses for the excess heat. One study involves the beneficial uses of low-grade heat in urban systems. An example is the use of discharge heat to increase the rate and effectiveness of secondary sewage treatment processes. Another possibility is the use of treated sewage effluent in cooling towers, where the nutrients can be substantially concentrated by evaporation. If the evaporation water could be condensed and collected, it could become a source of pure water, while the concentrated nutrients could be recovered and recycled to the environment. Sea water might be disalienated in the cooling towers, providing pure water and minerals.

Controlled heated water added to natural bodies of water has been found to benefit a few forms of fish life, particularly shellfish. Tests demonstrate that rejected heat can be used to extend the growing season for crops.

There has been increasing use of a system called cogeneration, where the spent steam from electrical generation is used in industrial processes which do not require high temperatures and pressures for their operation.

These concepts and many others such as home heating and cooling are incorporated into the idea of the Energy Center Complex. It is envisioned that an entire city would grow up associated with, and complimentary to, an electric power source. In this futuristic city, practically all the reject heat would be a beneficial resource instead of a waste product.

## Radioactive Wastes

Many of the waste products of nuclear power plants contain varying amounts of radioactivity.

The first point in the nuclear fuel cycle where radioactive wastes appear is with the mining and milling of the uranium-bearing ores. Although the decay of natural uranium eventually yields stable lead, there is a long series of intermediate radionuclides which account for more than 90 percent of the total radioactivity present in a specimen of natural uranium ore. These daughter products are left behind in the tailings, which are the residues from the milling process in which the uranium is chemically extracted from the crushed and ground ore. These tailings are normally stored on the surface near the mill, graded and diked as necessary to prevent erosion by surface waters and watered to prevent erosion by wind. When addition of tailings to a particular pile has been completed, a vegetation covering can be added as additional protection against leaching and erosion. It is possible for radon, a radioactive gas, to diffuse through a tailings pile from decay of the radium and disperse into the air. The Residual Radioactive Materials Act of 1978 establishes joint federal-state programs to minimize the potential problems from these mill tailings.

Other radioactive wastes result from the refining and enriching of the uranium and the fabrication of fuel elements. The relatively low levels of radioactivity in these wastes is due to the presence of naturally-occurring radioactive nuclides. They do not present a significant disposal problem.

The nuclear power plants themselves produce many kinds of radioactive waste with varied amounts of radioactivity. Some of these wastes may be released to the environment under carefully regulated conditions, while others require varying degrees of controlled storage.

Most nuclear facilities generate gaseous and liquid wastes which are contaminated with radioactive materials. Under strict regulation, some of these wastes can be treated and released to the environment. The gaseous wastes can be filtered and are sometimes stored temporarily to permit the decay of short-lived radionuclides. Liquid wastes can be treated by evaporation, ion exchange, or precipitation, so that the remaining concentration of radioactivity in the liquid is very low. Release of these treated liquids or gases to the surrounding water or air must be carefully monitored to insure that only very small amounts of radioactivity are put into the environment.

A wide variety of solid wastes containing radioactive materials are shipped from nuclear facilities to burial grounds which are operated under licenses from either the Nuclear Regulatory Commission or certain states which operate their own radiation control programs under agreements with the NRC. These burial grounds are selected after studies of local soil and weather conditions have shown an acceptable probability that the buried radioactive materials will not be moved from the site by the action of groundwater.

This general class of waste is frequently called low-level solid radioactive waste, although the term is not precise. Almost all facilities in the fuel cycle send wastes to the burial grounds. Some of the types of waste involved are as follows: filters from the clean-up of gaseous wastes; ion exchange resins, precipitates, or evaporator sludges from the clean-up of liquid wastes; concrete or other solids made from small batches of radioactive waste not practical to clean-up; absorbent paper, swabs, plastic sheeting, and similar materials from contamination control or clean-up work; defective or obsolete piping, motors, instrumentation, or other equipment.

The annual volume of this general category of waste is a few million cubic feet per year. This is very small compared with other types of solid wastes.

The spent fuel rods from nuclear power plants are highly radioactive, and their final disposal is a problem yet to be solved. It is a problem shared by wastes from the government weapons testing and nuclear-powered ship program. The amount of these defense wastes is many times larger than that from civilian nuclear power reactors. The defense programs had produced about 500,000 tons of highly radioactive wastes and 64 million cubic feet of less radioactive solid waste. Nuclear power plants have produced about 5,000 tons of spent fuel and 16 million cubic feet of low-level waste.

The high-level waste from both sources is currently in temporary storage awaiting a decision on the best method of more permanent disposal. The weapons waste is stored in tanks and burial pits at three government reservations. The spent fuel is stored in pools of water on the power plant sites. This storage at the site allows the short-lived radionuclides to decay and, thus, reduces the radioactivity of the spent fuel. It will probably be the first step in any disposal plan.

Most experts believe that long-lived radioactive waste should be concentrated and put into solid form, then placed into protective containers and stored deep underground in suitable geologic formations.

Radioactive waste is being solidified into glass in France, and U.S. researchers are looking at the possibility of a ceramic form, which would be more resistant to leaching by groundwater.

Scientists are looking at geologic formations such as salt beds, basalts, shales, and granites to determine which might be more suitable for long-term storage. The storage site must be one where groundwater cannot easily reach and where earthquakes are not likely.

A government task force called the Inter-agency Review Group on Nuclear Waste Management has been set up to study and report on the best methods for waste disposal. This group reports that a waste repository will probably not be available until 1988 to 1993.

The interagency group believes that the radioactive wastes can be successfully isolated for a few thousand years, but after that point, it is more difficult to be sure of success. Most of the radioactive materials would be harmless long before that time, but materials containing plutonium-239 would remain dangerous for many thousands of years.

One of the key decisions affecting waste management is that of reprocessing. If the spent fuel is considered a waste, it would be encapsulated in some very hard material and disposed of. If on the other hand reprocessing is to take place, the spent fuel would be treated to remove useful fuel. The remaining material would be a highly radioactive liquid which would be solidified before disposal.

Since any type of commercial power plant has a useful life of roughly 40 years, it is necessary to consider the disposal (or decommissioning) of a nuclear power plant. Except for the reactor vessel, most of the plant could be disposed of by conventional methods, with the materials being recycled or discarded. Many of the materials within the reactor vessel will have become radioactive. These materials and the reactor vessel itself would probably remain on the site for several years to allow the shorter half-lived materials to decay.

## Chapter 6

### THE EVENTS OF THREE MILE ISLAND

#### THE ACCIDENT

About 4 a.m. on Wednesday, March 28, 1979, a sequence of events began which added considerable fuel to the nuclear power controversy. At that time, at the Three Mile Island Unit 2 nuclear plant near Harrisburg, Pennsylvania, the main feedwater supply system went out of operation. This is the system that feeds water into the steam generator. The auxiliary system should have started automatically, but it did not because some valves had been left closed after a test of the system in the days prior to the accident. This was a violation of NRC regulations. Without a water supply, the steam generators dried out, resulting in a rise in the temperature and pressure of the cooling water. The turbine shut itself down instantly, and within seconds, the reactor's control rods automatically descended into the core and shut down the fission process. A relief valve released steam into the reactor containment vessel to reduce the pressure in the primary cooling system. This relief valve should have then closed; instead, it malfunctioned and remained open. Unknown to the reactor operators, this allowed the continuing release of radioactive steam and water into the containment building. This water overflowed the tanks that were supposed to hold it, flooding the floor of the building.

The emergency core cooling system started automatically at two minutes into the accident sequence and began to raise the coolant level. Soon afterward, a gauge in the control room indicated that the coolant level inside the system was adequate and, in fact, went off the scale on the high side. Thus, the operators shut off one of the two pumps in the emergency core cooling system. Shortly afterward still deceived by the erroneous gauge, the operators shut off the second pump. They

shut off these pumps because if the system were completely filled with water, as they thought was happening, they would have difficulty controlling the pressure. Around 5:30 a.m. they shut down the primary coolant pumps, which had begun to vibrate, apparently because they were pumping too little water. The operators feared that the vibration would destroy the pumps, and possibly cause a rupture in the primary coolant system. By the time the stuck relief valve was discovered and repaired, and the emergency core cooling system was turned on again, the coolant level had dropped so low that part of the core had been uncovered, resulting in substantial fuel damage.

Meanwhile the radioactive water from the containment building was being pumped into a storage tank in an auxiliary building. This pumping was done by sump pumps which operated automatically. When the storage tank was full, water spilled onto the floor and radioactive gases began to escape to the environment through the auxiliary building's ventilation system. This problem was discovered at about 9 a.m. The sump pump was turned off and the containment building was sealed off from the rest of the plant.

As the fuel heated, some of the fuel element cladding began to chemically react with the water, forming a hydrogen bubble at the top of the reactor pressure vessel. Reactor operators were unaware of the extent of this problem.

The most serious problem confronting operations personnel was getting enough cooling water into the reactor to begin to cool the core. This was finally accomplished through the use of the emergency core cooling system, and one of the main reactor coolant pumps could be started by 8 p.m.

On Thursday, the core appeared to be stabilized, but the operators were still having difficulty cooling it. Utility officials held a new conference in the morning saying that there had been little fuel damage, but later NRC officials



reported that fuel damage was much worse than previously thought. Low levels of radiation continued to be emitted as plant personnel tried to control the radioactive water on the floor of the auxiliary building.

Friday, March 30, is called Black Friday by many of those working at the plant. Starting about 6:40 a.m., there was a series of small gaseous releases of radioactivity from the auxiliary building. There was a larger release around 8:45 a.m. About that time, a helicopter which was monitoring radiation levels directly above the plant reported a radiation reading of 1200 mrem per hour. NRC headquarters in Washington mistakenly thought this measurement was from ground level outside the boundary of the plant, and they called Pennsylvania Civil Defense and told them that the area around the plant should be evacuated. The error was soon discovered, and the evacuation order was replaced with a directive that people within a 10 mile radius of the plant should stay indoors.

Around noon, in order to decrease the amount of radiation being released into the atmosphere, NRC ordered that all the contaminated water in the auxiliary building be pumped back into the primary containment. Also about noon, Governor Thornburgh, on the advice of NRC, closed the 23 schools in a five mile radius of the plant, and advised pregnant women and preschool children in that five mile radius to leave the area. As it turned out, most of the significant radiation releases that would take place during the incident had already occurred. Utility officials discounted the need for the evacuation, but they had little credibility by this time due to their previous overoptimistic reports. The governor's advisory triggered a general exodus with as many as 75,000 of the 975,000 persons in the four-county area leaving their homes. Because of overloaded telephone circuits in the area, President Carter ordered the installation of a direct line linking the governor's office, the White House, NRC headquarters, and the nuclear plant.

On Friday afternoon, NRC personnel detected the hydrogen bubble. The possibility of the bubble had not been considered in previous safety evaluations, and no one knew how to deal with it. The reactor was still stable and the fuel temperature was slowly coming down. But there was fear that if the system cooled down very much, the bubble would expand and restrict the flow of cooling water through the damaged core, possibly exposing the core again.

NRC personnel erroneously postulated that there could be a hydrogen explosion which could possibly breach the containment building and release serious amounts of radioactive materials to the environment. In actuality, there was never a danger of such an explosion because there was no oxygen in the reactor vessel. The chemical reaction which produced the hydrogen had consumed the oxygen from the water by oxidizing the fuel cladding.

About this time, the NRC official at the scene remarked to the press that there was a real possibility of a core meltdown. In the midst of the confusion, Harold Denton arrived to take control of the NRC staff and began the coordination of news releases.

NRC officials debated about whether they should recommend a general evacuation of the area around the plant. They also considered taking over operation of the crippled plant, but finally concluded that they did not have enough qualified operations staff to run the plant. Thus as Black Friday closed, the nation believed that a catastrophe was eminent.

Saturday arrived with continued tension and confusion. Low levels of radiation continued to leak from the plant. Governor Thornburgh told the people living near the plant that it was no longer necessary to stay indoors, but still advised pregnant women and preschool children to avoid coming within five miles of the plant. Plans were being prepared for the evacuation of everyone within 20 miles

of the plant.

The core was stable, but some hot spots remained in the fuel. The utility reported that the bubble was decreasing, but NRC reported that it was growing, increasing the possibility of an explosion. NRC advised the governor to evacuate the people up to 10 to 20 miles around the plant, but the governor decided such an evacuation was unwarranted. However, many who had remained up to this time decided to leave, and it is estimated that over the weekend 80,000 of the people living within 20 miles of the plant left their homes.

At 8:27 p.m., the Associated Press quoted an unnamed NRC source as saying that the bubble was so volatile it might explode at any minute. Harold Denton reported at 10:00 p.m. that this was false, and that the bubble had started to decrease. At about the same time, the governor was advised that President Carter would visit the plant the next day.

Sunday, April 1, was a better day at the plant. The core pressure and temperature remained stable and the bubble was slowly shrinking. Gases were being removed from the primary coolant water and vented to the containment. Hydrogen recombiners were converting the hydrogen and some of the containment oxygen into water.

President Carter, with his wife and some of his staff, arrived at the plant around 2 p.m. After a tour of the control room, he assured the citizens that everything possible was being done to assure the safety of the people in the area.

Monday, April 2, arrived with the core still stable. NRC, after first reporting that the bubble was slightly reduced, reported a dramatic decrease in the size of the bubble. They were not sure where it had gone, and could not promise that it would not form again. It was announced that the possibility of an evacuation was now remote.

Harold Denton told the press that the possibility of the hydrogen bubble exploding was never great. He also began recruiting some 200 nuclear experts from around the world to assist in the subsequent evaluation of the system.

By Tuesday, April 3, some schools in the area opened. Governor Thornburgh declared an end to the threat of an immediate catastrophe.

Joseph Califano, then head of the federal Department of Health, Education, and Welfare, stated that the maximum dose anyone might have received was about 80 mrem, or about the same as a couple of chest x-rays.

Some radiation was reported to be escaping from the plant, primarily from opening systems to take water samples.

In subsequent days, the pressure and temperature of the system remained stable and the fuel temperature slowly decreased. The pressurizer was occasionally vented to the containment to avoid possible return of the bubble. The hydrogen recombiners continued to lower the hydrogen content of the containment building. By April 9, the dissolved gases in the primary coolant were essentially eliminated, and Governor Thornburgh lifted his advisory that pregnant women and preschool children stay out of the area.

Finally, on April 27, nearly a month after the accident, cold shutdown was achieved. The primary pumps were shut off and the reactor was kept cool by the natural circulation of water between the core and the A steam generator. The massive clean-up job remained to be done.

There were several assessments of the radiation exposure to the population around the plant. The normal background radiation in the area is about 125 mrem per year. The maximum dose that anyone in the public could have received occurred at the bridge on the north side of the plant boundary as it connects to the main-

land. It was computed that if someone had stayed at that point 24 hours a day during the incident, that person would have received a total dose of about 85 mrem. The maximum actually received by any individual was less than this value.

The department of Health, Education and Welfare calculated that the total dose to the two million person within 50 miles of the plant was about 3,500 person-rems. The National Academy of Science estimates that this exposure could cause an additional one to five cancer deaths in the population of 166,000 people living within 10 miles of the plant within 20 years following exposure. The same population would normally be expected to have 45,000 cancer cases over the next 20 years.

Very little radioactive iodine was found in milk, well below the allowable limits and considerably less than that caused in the area by Chinese bomb tests over the last 10 years.

The accident pointed out some serious design deficiencies in the plant, including its monitoring systems. This led to the subsequent shutdown of similar plants until the deficiencies were corrected. It also showed the need to upgrade the training of reactor operators and the licensing procedures for nuclear plants. Much of the safety systems that the training and licensing stress pertain to a sudden large break in the primary coolant line. They were not prepared for events which occurred over a period of time and involved relatively small leaks.

The incident showed that the utility had inadequate numbers of personnel on hand to handle such a problem. It also showed a need for better radiation monitoring systems near the plant.

The complete effect of the accident on the future of nuclear power is not known, but it has certainly increased the apprehension of many people about this

energy source. Supporters of nuclear power say that the lessons learned from the accident will make nuclear power safer.

A socio-economic study of the accident, commissioned by the NRC, estimated that 144,000 persons left their homes, at a cost of \$18.2 million in evacuation expenses and lost wages. The independent study also found that nearly one in every five persons living near the plant has considered moving elsewhere because of their continuing fear of accidents and radioactive emissions. Twenty-two percent of the respondents said some member of their family suffered extreme emotional upset during the two-week emergency period.

There have been many investigations into the causes and effects of the accident at Three Mile Island. One major study was done by a 12-member panel appointed by President Carter. This group was called the President's Commission on the Accident at Three Mile Island, and was also known as the Kemeny Commission after its chairman, John G. Kemeny, president of Dartmouth College. After a six-month investigation, the commission concluded that the utility company's operators were insufficiently trained to cope with the accident. They also concluded that the Nuclear Regulatory Commission is unable to provide an acceptable level of safety in nuclear power plants. In light of their conclusions, the panel recommended fundamental changes in both the nuclear industry and NRC.

The commission called for abolishing the Nuclear Regulatory Commission and replacing it with an independent agency within the executive branch, headed by an administrator appointed by the President and monitored by a Congressional committee. Other major recommendations called for establishing agency-accredited training schools for reactor operators, establishing a program to set and monitor safety standards, initiating studies on health and safety matters relating to nuclear power, redesigning instruments to provide more reliable data, licensing new reactors

only in states with emergency response plants, periodic review of licenses, and locating plants away from densely populated areas.

There was no recommendation to ban construction of future nuclear plants, although such a moratorium was considered. The commission concluded that long-term health costs of the accident at Three Mile Island are likely to be negligible, but the short-term mental stress was severe.

#### TMI-II--One Year Later

The progress in cleaning up TMI-II has been very slow, and has been punctuated by a series of minor controlled and uncontrolled releases of radioactivity. Some progress has been made in the clean-up of the auxiliary and fuel handling buildings, but no clean-up of the primary containment has been accomplished.

In October of 1979, the Nuclear Regulatory Commission finally approved the use of the Epicor-II system to process 400,000 gallons of intermediate level radioactive water stored in tanks in the auxiliary and fuel handling buildings. By April 13, 1980, 182,000 gallons had been processed. Samples of this processed water indicate that it is clean enough to discharge into the Susquehanna River without violating federal standards, but NRC currently is requiring Metropolitan Edison to store the processed water on site.

Yet to be processed are some 600,000 gallons of highly radioactive water that covers the basement of the containment building to a depth of seven feet. A system more sophisticated than the Epicor-II will be needed to process this water. And before it can be processed, a method must be chosen to remove the krypton-85 gas from inside the primary containment.

There is approximately 57,000 curies of krypton-85 inside the containment building at a concentration of about one microcurie per cubic centimeter of air.

This is about one million times higher than the maximum permissible concentration of this gas for continual exposure of occupational workers in restricted areas. Thus access to the building, even with protective clothing, is severely limited.

The damaged reactor core is being maintained in a shutdown configuration through the use of large amounts of boron in the cooling water to absorb neutrons. The building's air cooling system is still operating and is maintaining a slight negative pressure with respect to the outside atmosphere. Thus any leaking that is taking place is outside air leaking into the containment, and no significant building atmosphere is leaking into the environment. It is unknown how long this cooling system will continue to operate without maintenance.

On November 13, 1979, Metropolitan Edison submitted to NRC a request for authorization to remove the krypton-85 by controlled purging. In this request, they compared purging with four other methods, namely charcoal absorption, gas compression, cryogenic processing, and selective absorption. The utility stated that these alternative methods would require a delay of between 20 months and 4 years in further clean-up of the primary containment, would cost between 3 and 160 million dollars more, and would require the continual on-site storage of the krypton-85 for up to 100 years. These approaches would significantly lower the dose to the surrounding population from the maximum beta skin dose of 16 mrem and gamma whole body dose of 0.2 mrem which are estimated for the purging approach.

In March 1980, the NRC staff released its report NUREG-0662 for public comment. This report essentially agreed with the proposal of Metropolitan Edison and recommended to the NRC commissioners that purging of the reactor building atmosphere to the environment be selected as the decontamination option for the disposal of krypton-85. This report, and the public hearings held after its release, have led to widespread public opposition to the purging option and further increased public mistrust of NRC and the utility.



## APPENDIX A

### GLOSSARY OF TERMS

The following terms are included to aid you in your understanding of the material included in the text and of the terms you will encounter as you investigate the effects of power generation. Many of the nuclear terms are excerpted from the U.S. Energy Research and Development Administration publication, *The Environmental Impact of Electric Power Generation: Nuclear and Fossil*. ERDA-69, 1975.

absorbed dose	When ionizing radiation passes through matter, some of its energy is imparted to the matter. The amount absorbed per unit mass of irradiated material is called the absorbed dose, and is measured in rems and rads.
absorber	Any material that absorbs or diminishes the intensity of ionizing radiation. Neutron absorbers, like boron, hafnium and cadmium are used in control rods for reactors. Concrete and steel absorb gamma rays and neutrons in reactor shields. A thin sheet of paper or metal will absorb or attenuate alpha particles and all except the most energetic beta particles.
absorption	The process by which the number of particles or photons entering a body of matter is reduced by interaction of the particles or radiation with the matter; similarly, the reduction of the energy or particles or photons while traversing a body of matter.
activation	The process of making a material radioactive by bombardment with neutrons, protons, or other nuclear particles or photons.
acute radiation sickness syndrome	An acute organic disorder that follows exposure to relatively severe doses of ionizing radiation. It is characterized by nausea, vomiting, diarrhea, blood cell changes, and in later stages of hemorrhage and loss of hair.
air sampling	The collection and analysis of samples of air to measure its radioactivity or to detect the presence of radioactive substances, particulate matter or chemical pollutants.
alpha particle	(Symbol $\alpha$ ) A positively charged particle emitted by certain radioactive materials. It is made up of two neutrons and two protons bound together. Hence, it is identical with the nucleus of a helium atom. It is the least penetrating of the three common types of decay radiation.
atom	A particle of matter whose nucleus is indivisible by chemical means. It is the fundamental building block of the chemical elements.
atomic bomb	A bomb whose energy comes from the fission of heavy elements such as uranium-235 and plutonium-239.
Atomic Energy Commission	(Abbreviation AEC) The federal agency which previously had statutory responsibilities for atomic energy matters. Functions taken over in 1974 by Energy Research and Development Administration and Nuclear Regulatory Commission.
atomic mass	(see atomic weight, mass)
atomic mass unit	(Abbreviation amu) One-twelfth the mass of a neutral atom of the most abundant isotope of carbon, carbon-12.
atomic number	(Symbol Z) The number of protons in the nucleus of an atom, and also its positive charge. Each chemical has its characteristic atomic number, and the numbers of the known elements form a complete series from 1 (hydrogen) to 105.
atomic reactor	A nuclear reactor.
atomic weight	The mass of an atom relative to other atoms. The present-day basis of the scale of atomic weights is carbon; the most common isotope of this element has

arbitrarily been assigned an atomic weight of 12. The unit of the scale is one-twelfth the weight of the carbon-12 atom, or roughly the mass of one proton or one neutron. The atomic weight of any element is approximately equal to the total number of protons and neutrons in its nucleus.

autoradiograph	A photographic record of radiation from radioactive material in an object, made by placing the object very close to a photographic film or emulsion. The process is called autoradiography. It is used, for instance, to locate radioactive atoms or tracers in metallic or biological samples.
background radiation	The radiation in man's natural environment, including cosmic rays and radiation from the naturally radioactive elements, both outside, and inside the bodies of humans and animals. It is also called natural radiation. The term may also mean radiation that is unrelated to a specific experiment.
backscatter	When radiation of any kind strikes matter (gaseous, solid or liquid), some of it may be reflected or scatter back in the general direction of the source. An understanding or exact measurement of the amount of backscatter is important when beta particles are being counted in an ionization chamber, in medical treatment with radiation, or in the use of industrial radioisotopic thickness gauges.
barrier shield	A wall or enclosure shielding the operator from an area where radioactive material is being used or processed by remote control equipment.
beta particle	(Symbol $\beta^-$ ) An elementary particle emitted from a nucleus during radioactive decay, with a single electrical charge and a mass equal to 1/1837 that of a proton. A negatively charged beta particle is identical to an electron. A positively charged beta particle is called a positron. Beta radiation may cause skin burns, and beta-emitters are harmful if they enter the body. Beta particles are easily stopped by a thin sheet of metal.
BeV	Symbol for a billion ( $10^9$ ) electron volts. (See electron volt.)
binding energy	The binding energy of a nucleus is the minimum energy required to dissociate it into its component neutrons and protons.
biological dose	The radiation dose absorbed in biological material. Measured in rems.
biological half life	The time required for a biological system, such as a human or animal, to eliminate by natural processes half the amount of a substance (such as a radioactive material) that has entered it.
biological shield	A mass of absorbing material placed around a reactor or radioactive source to reduce the radiation to a level safe for humans.
body burden	The amount of radioactive material present in the body of a human or an animal.
boiling water reactor	A reactor in which water, used as both coolant and moderator, is allowed to boil in the core. The resulting steam can be used directly to drive a turbine.
bone seeker	A radioisotope that tends to accumulate in the bones when it is introduced into the body. An example is strontium-90, which behaves chemically like calcium.
breeder reactor	A reactor that produces more fissionable fuel than it consumes. The new fissionable material is created by capture in fertile materials of neutrons from fission. The process by which this occurs is known as breeding.
BTU	British Thermal Unit. The amount of heat required to change the temperature of one pound of water one degree Fahrenheit.
by-product material	Any radioactive material (except source material for fissionable material) obtained during the production or use of source material or fissionable material. It includes fission products and many other radioisotopes produced in nuclear reactors.

calorie (large calorie)	The amount of heat required to change the temperature of one kilogram of water one degree Centigrade.
carbon oxides	Compounds of carbon and oxygen produced when the carbon of fossil fuels combines with oxygen during burning. The two most common such oxides are carbon monoxide, a very poisonous gas, and carbon dioxide.
cask	A heavily shielded container used to store and/or ship radioactive materials.
cathode rays	A stream of electrons emitted by the cathode, or negative electrode, of a gas-discharge tube or by a hot filament in a vacuum tube, such as a television tube.
chain reaction	A reaction that stimulates its own repetition. In a fission chain reaction, a fissionable nucleus absorbs a neutron and fissions, releasing additional neutrons. These in turn can be absorbed by other fissionable nuclei, releasing still more neutrons. A fission chain reaction is self-sustaining when the number of neutrons released in a given time equals or exceeds the number of neutrons lost by absorption in nonfissioning material or by escape from the system.
charged particle	An ion; an elementary particle that carries a positive or negative electric charge.
chromosome	The determiner of heredity within a cell.
cladding	The outer jacket of nuclear fuel elements. It prevents corrosion of the fuel by the coolant and the release of fission products into the coolant. Aluminum or its alloys, stainless steel and zirconium alloys are common cladding materials.
closed-cycle reactor system	A reactor design in which the primary heat of fission is transferred outside the reactor core to do useful work by means of a coolant circulating in a completely closed system that includes a heat exchanger.
community	All the plant and animal species that live and interact in a particular environment.
containment	The provision of a gas-tight shell or other enclosure around a reactor to confine fission products that otherwise might be released to the atmosphere in the event of an accident.
containment vessel	A gas-tight shell or other enclosure around a reactor.
control rod	A rod, plate or tube containing a material such as hafnium, boron, etc. used to control the power of a nuclear reactor. By absorbing neutrons, a control rod prevents the neutrons from causing further fission.
coolant	A substance circulated through a nuclear reactor to remove or transfer heat. Common coolants are water, heavy air, air, carbon dioxide, liquid sodium and sodium-potassium alloy.
cooling tower	A tower designed to aid in the cooling of water that was used to condense the steam after it left the turbines of a power plant.
core	The central portion of a nuclear reactor containing the fuel elements and usually the moderator, but not the reflector.
counter	A general designation applied to radiation detection instruments or survey meters that detect and measure radiation.

critical mass	The smallest mass of fissionable material that will support a self-sustaining chain reaction under stated conditions.
criticality	The state of a nuclear reactor when it is just sustaining a chain reaction.
curie	(Abbreviation Ci) The basic unit to describe the intensity of radioactivity in a sample of material. The curie is equal to 37 billion disintegrations per second, which is approximately the rate of decay of 1 gram of radium. A curie is also a quantity of any nuclide having 1 curie of radioactivity. Named by Marie and Pierre Curie, who discovered radium in 1898.
daughter	A nuclide formed by the radioactive decay of another nuclide, which in this context is called the parent. (See radioactive series.)
decay chain	A radioactive series.
decay heat	The heat produced by the decay of radioactive nuclides.
decay, radioactive	The spontaneous transformation of one nuclide into a different nuclide or into a different energy state of the same nuclide. The process results in a decrease, with time, of the number of the original radioactive atoms in a sample. It involves the emission from the nucleus of alpha particles, beta particles (or electrons), or gamma rays; or the nuclear capture or ejection of orbital electrons; or fission. Also called radioactive disintegration.
decontamination	The removal of radioactive contaminants from surfaces or equipment, as by cleaning or washing with chemicals.
detector	Material or device that is sensitive to radiation and can produce a response signal suitable for measurement or analysis. A radiation detection instrument.
deuterium	(Symbol $^2\text{H}$ or D) An isotope of hydrogen whose nucleus contains one neutron and one proton and is therefore about twice as heavy as the nucleus of normal hydrogen, which is only a single proton. Deuterium is often referred to as heavy hydrogen; it occurs in nature as 1 atom to 6500 atoms of normal hydrogen. It is nonradioactive. (See heavy water.)
deuteron	The nucleus of deuterium. It contains one proton and one neutron.
dose	(See absorbed dose, biological dose, maximum permissible dose, threshold dose.)
dose equivalent	A term used to express the amount of effective radiation when modifying factors have been considered. The product of absorbed dose multiplied by a quality factor multiplied by a distribution factor. It is expressed numerically in rems.
dose rate	The radiation dose delivered per unit time. Measured, for instance, in rems per hour.
dosimeter	A device that measures radiation dose, such as a film badge or ionization chamber.
doubling dose	Radiation dose which would eventually cause a doubling of gene mutations.
ecology	The science dealing with the relationship of all living things with each other and with their environment.
ecosystem	A complex of the community of living things and the environment forming a functioning whole in nature.
efficiency	That percentage of the total energy content of a power plant's fuel which is converted into electricity. The remaining energy is lost to the environment as heat.
electron	(Symbol $e^-$ ) An elementary particle with a unit negative charge and a mass $1/1837$ that of the proton. Electrons surround the positively charged nucleus and determine the chemical properties of the atom. Positive electrons, or positrons, also exist for brief periods of time as the result of positron decay.

electron volt (Abbreviation ev or eV) The amount of kinetic energy gained by an electron when it is accelerated through an electric potential of 1 volt. It is equivalent to  $1.603 \times 10^{-12}$  erg. It is a unit of energy, or work, not of voltage.

element One of the 105 known chemical substances that cannot be divided into simpler substances by chemical means. A substance whose atoms all have the same atomic number. Examples are hydrogen, lead, and uranium. Not to be confused with fuel element.

energy The ability to do work.

Energy Research and Development Administration (Abbreviation ERDA) The independent executive agency of the federal government with responsibility for management of research and development in all energy matters. Its functions were taken over by the Department of Energy in 1977.

enrichment (See isotopic enrichment)

environment The total surroundings of an organism which act upon it.

exclusion area An area immediately surrounding a nuclear reactor where human habitation is prohibited to assure safety in the event of an accident.

excursion A sudden, very rapid rise in the power level of a reactor caused by supercriticality. Excursions are usually quickly suppressed by the negative temperature coefficient of the reactor and/or by automatic control rods.

fast breeder reactor A reactor that operates with fast neutrons and produces more fissionable material than it consumes.

fast neutron A neutron with kinetic energy greater than approximately 1,000,000 electron volts.

fast reactor A reactor in which the fission chain reaction is sustained primarily by fast neutrons rather than by slow-moving neutrons. Fast reactors contain little or no moderator to slow down the neutrons from the speeds at which they are ejected from fissioning nuclei.

fertile material A material, not itself fissionable by thermal neutrons, which can be converted into a fissionable material by irradiation in a reactor. There are two basic fertile materials, uranium-238 and thorium-232. When these fertile materials capture neutrons, they are partially converted into fissionable plutonium-239 and uranium-233, respectively.

electron volt	(Abbreviation eV or eV) The amount of kinetic energy gained by an electron when it is accelerated through an electric potential of 1 volt. It is equivalent to $1.603 \times 10^{-12}$ erg. It is a unit of energy, or work, not of voltage.
element	One of the 105 known chemical substances that cannot be divided into simpler substances by chemical means. A substance whose atoms all have the same atomic number. Examples are hydrogen, lead, and uranium. Not to be confused with fuel element.
energy	The ability to do work.
Energy Research and Development Administration	(Abbreviation ERDA) The independent executive agency of the federal government with responsibility for management of research and development in all energy matters. Its functions were taken over by the Dept. of Energy in 1977.
enrichment	(See isotopic enrichment)
environment	The total surroundings of an organism which act upon it.
exclusion area	An area immediately surrounding a nuclear reactor where human habitation is prohibited to assure safety in the event of an accident.
excursion	A sudden, very rapid rise in the power level of a reactor caused by supercriticality. Excursions are usually quickly suppressed by the negative temperature coefficient of the reactor and/or by automatic control rods.
fast breeder reactor	A reactor that operates with fast neutrons and produces more fissionable material than it consumes.
fast neutron	A neutron with kinetic energy greater than approximately 1,000,000 electron volts.
fast reactor	A reactor in which the fission chain reaction is sustained primarily by fast neutrons rather than by slow-moving neutrons. Fast reactors contain little or no moderator to slow down the neutrons from the speeds at which they are ejected from fissioning nuclei.
fertile material	A material, not itself fissionable by thermal neutrons, which can be converted into a fissionable material by irradiation in a reactor. There are two basic fertile materials, uranium-238 and thorium-232. When these fertile materials capture neutrons, they are partially converted into fissionable plutonium-239 and uranium-233, respectively.
film badge	A light-tight package of photographic film worn like a badge by workers in nuclear industry or research, used to measure exposure to ionizing radiation. The absorbed dose can be calculated by the degree of film darkening caused by the irradiation.
fissile material	While sometimes used as a synonym for fissionable material, this term has also acquired a more restricted meaning; namely, any material fissionable by neutrons of all energies, including thermal (slow) neutrons as well as fast neutrons. The three primary fissile materials are uranium-233, uranium-235 and plutonium-239.
fission	The splitting of a heavy nucleus into two approximately equal parts (which are nuclei of lighter elements), accompanied by the release of a relatively large amount of energy and generally one or more neutrons. Fission can occur spontaneously, but usually is caused by nuclear absorption of gamma rays, neutrons or other particles.
fission fragments	The two or more nuclei which are formed by the fission of a nucleus. Also referred to as primary fission products. They are of medium atomic weight, and are radioactive.
fission products	The nuclei (fission fragments) formed by the fission of heavy elements, plus the nuclides formed by the fission fragments' radioactive decay.

fissionable material	Commonly used as a synonym for fissile material. The meaning of this term has also been extended to include material that can be fissioned by fast neutrons only, such as uranium-238. Used in reactor operations to mean fuel.
flux (neutron)	A measure of the intensity of neutron radiation. It is the number of neutrons passing through one square centimeter of a given target in one second. Expressed as $n \times v$ , where $n$ = the number of neutrons per cubic centimeter and $v$ = their velocity in centimeters per second.
food chain	The pathways by which any material (such as radioactive material from fallout) passes from the first absorbing organism through plants and animals to humans.
fuel (nuclear)	Fissionable material used or usable to produce energy in a reactor. Also applied to a mixture, such as natural uranium, in which only part of the atoms are readily fissionable, if the mixture can be made to sustain a chain reaction.
fuel cycle	The series of steps involved in supplying fuel for nuclear power reactors. It includes mining, refining, the original fabrication of fuel elements, their use in a reactor, chemical processing to recover the fissionable material remaining in the spent fuel, re-enrichment of the fuel material, and refabrication into new fuel elements.
fuel element	A rod, tube, plate or other mechanical shape or form into which nuclear fuel is fabricated for use in a reactor. (Not to be confused with element.)
fuel reprocessing	The processing of reactor fuel to recover the unused fissionable material.
fusion	The formation of a heavier nucleus from two lighter ones (such as hydrogen isotopes), with the attendant release of energy.
gamma rays	(Symbol $\gamma$ ) High energy, short wave length electromagnetic radiation originating in the nucleus. Gamma radiation frequently accompanies alpha and beta emissions and always accompanies fission. Gamma rays are very penetrating and are best stopped or shielded against by dense materials, such as lead or depleted uranium. Gamma rays are essentially similar to x-rays, but are usually more energetic.
gas cooled reactor	A nuclear reactor in which a gas is the coolant.
gaseous diffusion (plant)	A method of isotopic separation based on the fact that gas atoms or molecules with different masses will diffuse through a porous barrier (or membrane) at different rates. The method is used by the AEC to separate uranium-235 from uranium-238; it requires large gaseous diffusion plants and enormous amounts of electric power.
Geiger-Muller counter	A radiation detection and measuring instrument. It consists of a gas-filled Geiger-Muller tube containing electrodes, between which there is an electrical voltage but no current flowing. When ionizing radiation passes through the tube, a short, intense pulse of current passes from the negative electrode to the positive electrode and is measured or counted. The number of pulses per second measures the intensity of radiation. It was named for Hans Geiger and W. Muller who invented it in the 1920s. It is sometimes called simply a Geiger counter, or a G-M counter.
genetic effects of radiation	Radiation effects that can be transferred from parent to offspring. Any radiation-caused changes in the genetic material of sex cells.
genetically significant dose	A population-averaged dose which estimates the potential genetic effects of radiation on future generations. It takes into consideration the number of people in various age groups, the average dose to the reproductive organs to which people in these groups are exposed, and their expected number of future children.

graphite (reactor grade)

A very pure form of carbon used as a moderator in nuclear reactors.

half life

The time in which half the atoms of a particular radioactive substance disintegrate to another nuclear form. Measured half lives vary from millionths of a second to billions of years. Also called physical half life. (See decay, radioactive)

half life, biological

(See biological half life.)

half life, effective

The time required for a radionuclide contained in a biological system, such as a human or an animal, to reduce its activity by half as a combined result of radioactive decay and biological elimination. (Compare biological half life and half life.)

half-thickness

The thickness of any given absorber that will reduce the intensity of a beam of radiation to one-half its initial value.

health physics

The science concerned with recognition, evaluation and control of health hazards from ionizing radiation.

heat exchanger

Any device that transfers heat from one fluid (liquid or gas) to another or to the environment.

heat sink

Anything that absorbs heat; usually part of the environment, such as the air, a river or outer space.

heavy water

(Symbol D<sub>2</sub>O) Water containing significantly more than the natural proportions (one in 6500) of heavy hydrogen (deuterium) atoms to ordinary hydrogen atoms. Heavy water is used as a moderator in some reactors because it slows down neutrons effectively and also has a low cross section for absorption of neutrons.

heavy water moderated reactor

A reactor that uses heavy water as its moderator. Heavy water is an excellent moderator and thus permits the use of inexpensive (unenriched) uranium as a fuel.

induced radioactivity

Radioactivity that is created when substances are bombarded with neutrons as from a nuclear explosion or in a reactor, or with charged particles and photons produced by accelerators.

intensity

The energy or the number of photons or particles of any radiation incident upon a unit area or flowing through a unit of solid material per unit of time. In connection with radioactivity, the number of atoms disintegrating per unit of time.

ion

An atom or molecule that has lost or gained one or more electrons. By this ionization it becomes electrically charged. Examples: an alpha particle, which is a helium atom minus two electrons; a proton, which is hydrogen atom minus its electron.

ionization

The process of adding one or more electrons to, or removing one or more electrons from, atoms or molecules, thereby creating ions. High temperatures, electrical discharges, or nuclear radiations can cause ionization.

ionization chamber

An instrument that detects and measures ionizing radiation by measuring the electrical current that flows when radiation ionizes gas in a chamber, making the gas a conductor of the electricity.

ionization event

An occurrence in which an ion or group of ions is produced; for example, by passage of a charged particle through matter.



ionizing radiation	Any radiation capable of displacing electrons from atoms or molecules, thereby producing ions. Examples: alpha, beta, gamma radiation, short-wave ultraviolet light. Ionizing radiation may produce severe skin or tissue damage.
irradiation	Exposure to radiation, as in a nuclear reactor.
isotope	One of two or more atoms with the same atomic number (the same chemical element) but with different atomic weights. An equivalent statement is that the nuclei of isotopes have the same number of protons, but different numbers of neutrons. Thus carbon-12, carbon-13 and carbon-14 are isotopes of the element carbon; the numbers denoting the approximate atomic weights. Isotopes usually have very nearly the same chemical properties, but somewhat different physical properties.
isotope separation	The process of separating isotopes from one another, or changing their relative abundances, as by gaseous diffusion or electromagnetic separation. Isotope separation is a step in the isotopic enrichment process.
isotopic enrichment	A process by which the relative abundances of the isotopes of a given element are altered, thus producing a form of the element which has been enriched in one particular isotope and depleted in its other isotopic forms.
kilowatt hour	One kilowatt of electricity expended for one hour.
kilo-	A prefix that multiplies a basic unit by 1000.
lethal dose	A dose of ionizing radiation sufficient to cause death. Median lethal dose (MLD or LD-50) is the dose required to kill within a specific period of time (usually 30 days) half of the individuals in a large group of organisms similarly exposed. The LD-50/30 for man is about 400,000 to 450,000 nrem.
low population zone	An area of low population density sometimes required around a nuclear installation. The number and density of residents is of concern in providing, with reasonable probability, that effective protection measures can be taken if a serious accident should occur.
mass	The quantity of matter in a body. Often used as a synonym for weight, which, strictly speaking, is the force exerted on a body by the earth.
mass-energy equation	The statement developed by Albert Einstein, German-born American physicist, that the mass of a body is a measure of its energy content, as an extension of his 1905 special theory of relativity. The statement was subsequently verified experimentally by measurements of mass and energy in nuclear reactions. The equation, usually given as $E = mc^2$ , shows that when the energy of a body changes by an amount $E$ (no matter what form the energy takes), the mass, $m$ , of the body will change by an amount equal to $E/c^2$ . The factor $c^2$ , the square of the speed of light in a vacuum, may be regarded as the conversion factor relating units of mass and energy. The equation predicted the possibility of releasing enormous amounts of energy by the conversion of mass to energy. It is also called the Einstein equation.
matter	The substance of which a physical object is composed. All materials in the universe have the same inner nature, that is, they are composed of atoms, arranged in different (and often complex) ways; the specific atoms and the specific arrangements identify the various materials.
maximum credible accident	The most serious reactor accident that can reasonably be imagined from any adverse combination of equipment malfunction, operating errors and other foreseeable causes. The term is used to analyze the safety characteristics of a reactor. Reactors are designed to be safe even if a maximum credible accident should occur.

maximum permissible dose	That dose of ionizing radiation established by competent authorities as an amount below which there is no reasonable expectation of risk to human health, and which at the same time is somewhat below the lowest level at which a definite hazard is believed to exist. (See radiation protection guide).
mean life	The average time during which an atom, an excited nucleus, a radionuclide or a particle exists in a particular form.
median lethal dose	(See lethal dose.)
mega-	A prefix that multiplies a basic unit by 1,000,000.
Mev	One million ( $10^6$ ) electron volts. Also written as MeV.
milli-	A prefix that multiplies a basic unit by 1/1000.
moderator	A material, such as ordinary water, heavy water, or graphite, used in a reactor to slow down high velocity neutrons, thus increasing the likelihood of further fission.
molecule	A group of atoms held together by chemical forces. The atoms in the molecule may be identical, as in $H_2$ , $S_2$ , and $S_8$ , or different, as in $H_2O$ and $CO_2$ . A molecule is the smallest unit of a compound which can exist by itself and retain all its chemical properties. (Compare atom, ion.)
mutation	A permanent transmissible change in the characteristics of an offspring from those of its parents.
natural radiation or natural radioactivity	Background radiation.
natural uranium	Uranium as found in nature. It contains 0.7 per cent of uranium-235, 99.3 per cent of uranium-238 and a trace of uranium-234. It is also called normal uranium.
neutron	(Symbol n) An uncharged elementary particle with a mass slightly greater than that of the proton, and found in the nucleus of every atom heavier than hydrogen-1. A free neutron is unstable and decays with a half life of about 13 minutes into an electron, proton and neutron. Neutrons sustain the fission chain reaction in a nuclear reactor.
neutron capture	The process in which an atomic nucleus absorbs or captures a neutron.
nuclear energy	The energy liberated by a nuclear reaction (fission or fusion) or by radioactive decay.
nuclear power plant	Any device, machine or assembly that converts nuclear energy into some form of useful power, such as mechanical or electrical power. In a nuclear electric power plant, heat produced by a reactor is generally used to make steam to drive a turbine that in turn drives an electric generator.
nuclear reaction	A reaction involving a change in an atomic nucleus, such as fission, fusion, neutron capture, or radioactive decay, as distinct from a chemical reaction, which is limited to changes in the electron structure surrounding the nucleus.
nuclear reactor	A device in which a fission chain reaction can be initiated, maintained and controlled. Its essential component is a core with fissionable fuel. It usually has a moderator, a reflector, shielding, coolant and control mechanisms. Sometimes called an atomic furnace, it is the basic machine of nuclear energy.



power reactor	A reactor designed to produce useful nuclear power, as distinguished from reactors used primarily for research, for producing radiation or fissionable materials or for reactor component testing.
pressure vessel	A strong-walled container housing the core of most types of power reactors; it usually also contains moderator, reflector, thermal shield and control rods.
pressurized water reactor	A power reactor in which heat is transferred from the core to a heat exchanger by water kept under high pressure to achieve high temperature without boiling in the primary system. Steam is generated in a secondary circuit. Many reactors producing electric power are pressurized water reactors.
primary fission products	Fission fragments.
protection	Provisions to reduce exposure of persons to radiation. For example, protective barriers to reduce external radiation or measures to prevent inhalation of radioactive materials.
quality factor (Q)	The factor by which absorbed dose is to be multiplied to obtain a quantity that expresses, on a common scale of all ionizing radiations, the irradiation incurred by exposed persons. It is used because some types of radiation such as alpha particles are more biologically damaging than other types.
rad	(Acronym for radiation absorbed dose) The basic unit of absorbed dose of radiation. A dose of one rad means the absorption of 100 ergs of radiation energy per gram of absorbing material.
radiation	The emission and propagation of energy through matter or space by means of electromagnetic disturbances which display both wave-like and particle-like behavior; in this context the particles are known as photons. Also, the energy so propagated. The term has been extended to include streams of fast-moving particles (alpha and beta particles, free neutrons, cosmic radiation, etc.). Nuclear radiation is that emitted from atomic nuclei in various nuclear reactors, including alpha, beta and gamma radiation and neutrons.
radiation area	Any accessible area in which the level of radiation is such that a major portion of an individual's body could receive in any one hour a dose in excess of 5 millirem, or in any five consecutive days a dose in excess of 150 millirem.
radiation burn	Radiation damage to the skin.
radiation damage	A general term for the harmful effects of radiation on matter.
radiation detection instrument	Devices that detect and record the characteristics of ionizing radiation.
radiation monitoring	Continuous or periodic determination of the amount of radiation present in a given area.
radiation protection	Legislation and regulations to protect the public and laboratory or industrial workers against radiation. Also measures to reduce exposure to radiation.
radiation protection guide	The officially determined radiation doses which should not be exceeded without careful consideration of the reasons for doing so. These are equivalent to the older term maximum permissible dose.
radiation shielding	Reduction of radiation by interposing a shield of absorbing material between any radioactive source and a person, laboratory area or radiation-sensitive device.
radiation source	Usually a man-made sealed source of radioactivity used in teletherapy, radiography, as a power source for batteries, or in various types of industrial gauges. Machines such as accelerators and radioisotopic generators and natural radionuclides may also be considered sources.

radiation standards	Exposure standards, permissible concentrations, rules for safe handling, regulations for transportation, regulations for industrial control of radiation and control of radiation by legislative means. (See radiation protection, radiation protection guide.)
radiation sterilization	Use of radiation to cause a plant or animal to become sterile, that is, incapable of reproduction. Also the use of radiation to kill all forms of life (especially bacteria) in food, surgical sutures, etc.
radiation warning symbol	An officially prescribed symbol (a magenta trefoil on a yellow background) which should be displayed when a radiation hazard exists.
radioactive	Exhibiting radioactivity or pertaining to radioactivity.
radioactive contamination	Deposition of radioactive material in any place where it may harm persons, spoil experiments or make products or equipment unsuitable or unsafe for some specific use. The presence of unwanted radioactive material found on the walls of vessels in used-fuel processing plants, or radioactive material that has leaked into a reactor coolant. Often referred to only as contamination.
radioactive dating	A technique for measuring the age of an object or sample of material by determining the ratios of various radioisotopes or products of radioactive decay it contains. For example, the ratio of carbon-14 to carbon-12 reveals the approximate age of bones, pieces of wood, or other archaeological specimen that contain carbon extracted from the air at the time of their origin.
radioactive isotope	A radioisotope.
radioactive series	A succession of nuclides, each of which transforms by radioactive disintegration into the next until a stable nuclide results. The first member is called the parent, the intermediate members are called daughters, and the final stable member is called the end product.
radioactive waste	(See waste, radioactive.)
radioactivity	The spontaneous decay or disintegration of an unstable atomic nucleus, usually accompanied by the emission of ionizing radiation. (Often shortened to activity.)
radioecology	The body of knowledge and the study of the effects of radiation on species of plants and animals in natural communities.
radioisotope	A radioactive isotope. An unstable isotope of an element that decays or disintegrates spontaneously, emitting radiation. More than 1300 natural and artificial radioisotopes have been identified.
radioisotopic generator	A small power generator that converts the heat released during radioactive decay directly into electricity. These generators generally produce only a few watts of electricity and use thermoelectric or thermionic converters. Some also function as electrostatic converters to produce a small voltage. Sometimes called an atomic battery.
radiology	The science which deals with the use of all forms of ionizing radiation in the diagnosis and treatment of disease.
radiomutation	A permanent transmissible change in form, quality or other characteristic of a cell or offspring from the characteristics of its parent, due to radiation exposure. (See genetic effects of radiation, mutation.)
radioresistance	A relative resistance to cells, tissues, organs, or organisms to the injurious action of radiation. (Compare radioresistance.)
radium	(Symbol Ra) A radioactive metallic element with atomic number 88. As found in nature, the most common isotope has an atomic weight of 226. It occurs in minute quantities associated with uranium in pitchblende, carnotite and other minerals.
radiosensitivity	A relative susceptibility of cells, tissues, organs or organisms to the injurious action of radiation. (Compare radioresistance.)

radon	(Symbol Rn) A radioactive element, one of the heaviest gases known. Its atomic number is 86, and its atomic weight is 222. It is a daughter of radium in the uranium radioactive series.
reactor	(See nuclear reactor.)
recycling	The reuse of fissionable material, after it has been recovered by chemical processing from spent or depleted reactor fuel, re-enriched and then refabricated into new fuel elements.
reflector	A layer of material immediately surrounding a reactor core which scatters back or reflects into the core many neutrons that would otherwise escape. The returned neutrons can then cause more fissions and improve the neutron economy of the reactor. Common reflector materials are graphite, beryllium and natural uranium.
regulating rod	A reactor control rod used for making frequent fine adjustment in reactivity.
relative biological effectiveness (RBE)	A factor used to compare the biological effectiveness of different types of ionizing radiation. It is the inverse ratio of the amount of absorbed radiation, required to produce a given effect, to a standard or reference radiation required to produce the same effect.
rem	(Acronym of roentgen equivalent man.) The unit of dose of any ionizing radiation which produces the same biological effect as a unit of absorbed dose or ordinary x-rays. The RBE dose (in rems) = RBE x absorbed dose (in rads).
rep	(Acronym for roentgen equivalent physical) An obsolete unit of absorbed dose of any ionizing radiation, with a magnitude of 93 ergs per gram. It has been superseded by the rad.
reprocessing	Fuel reprocessing.
roentgen	(Abbreviation r) A unit of exposure to ionizing radiation. It is that amount of gamma or x-rays required to produce ions carrying 1 electrostatic unit of electrical charge (either positive or negative) in 1 cubic centimeter of dry air under standard conditions. Named after Wilhelm Roentgen, German scientist who discovered x-rays in 1895.
roentgen equivalent, man	(See rem.)
roentgen rays	X-rays.
safety rod	A standby control rod used to shut down a nuclear reactor rapidly in emergencies.
scaler	An electronic instrument for rapid counting of radiation-induced pulses from Geiger counters or other radiation detectors. It permits rapid counting by reducing by a definite scaling factor the number of pulses entering the counter.
scram	The sudden shutdown of a nuclear reactor, usually by rapid insertion of the safety rods. Emergencies or deviations from normal reactor operation cause the reactor operator or automatic control equipment to scram the reactor.
shield (shielding)	A body of material used to reduce the passage of radiation.
somatic effects of radiation	Effects of radiation limited to the exposed individual, as distinguished from genetic effects, which also affect subsequent unexposed generations. Large radiation doses can be fatal. Smaller doses may make the individual noticeably ill, may merely produce temporary changes in blood-cell levels detectable only in the laboratory, or may produce no detectable effects whatever. Also called physiological effects of radiation. (Compare genetic effects of radiation.)

spent (depleted) fuel	Nuclear reactor fuel that has been irradiated (used) to the extent that it can no longer effectively sustain a chain reaction.
spill	The accidental release of radioactive material.
stable	Incapable of spontaneous change. Not radioactive.
stable isotope	An isotope that does not undergo radioactive decay.
subcritical assembly	A reactor consisting of a mass of fissionable material and moderator which cannot sustain a chain reaction. Used primarily for educational purposes.
subcritical mass	An amount of fissionable material insufficient in quantity or of improper geometry to sustain a fission chain reaction.
supercritical reactor	A reactor in which the power level is increasing. If uncontrolled, a supercritical reactor would undergo an excursion.
superheating	The heating of a vapor, particularly steam, to a temperature much higher than the boiling point at the existing pressure. This is done in power plants to improve efficiency and to reduce condensation in the turbines.
survey meter	Any portable radiation detection instrument especially adapted for surveying or inspecting an area to establish the existence and amount of radioactive material present.
thermal breeder reactor	A breeder reactor in which the fission chain reactor is sustained by thermal neutrons.
thermal pollution	Raising the temperature of a body of water such as a lake or stream to an undesirable level by the addition of heat. This heat may change the ecological balance of that body of water, making it impossible for some types of life to survive, or it may favor the survival of other organisms, such as algae.
thermal reactor	A reactor in which the fission chain reaction is sustained primarily by thermal neutrons. Most current reactors are thermal reactors.
thermal shield	A layer or layers of high density material located within a reactor pressure vessel or between the vessel and the biological shield to reduce radiation heating in the vessel and the biological shield.
thermonuclear reaction	A reaction in which very high temperatures allow the fusion of two light nuclei to form the nucleus of a heavier atom, releasing a large amount of energy. In a hydrogen bomb, the high temperature to initiate the thermonuclear reaction is produced by a preliminary fission reaction.
threshold dose	The minimum dose of radiation that will produce a detectable biological effect.
tracer, isotopic	An isotope of an element, a small amount of which may be incorporated into a sample of material (the carrier) in order to follow (trace) the course of that element through a chemical, biological or physical process, and thus also follow the larger sample. The tracer may be radioactive, in which case observations are made by measuring the radioactivity. If the tracer is stable, mass spectrometers or neutrons activation analysis may be employed to determine isotopic composition. Tracers also are called labels or tags, and materials are said to be labeled or tagged when radioactive tracers are incorporated in them.

turbine	A rotary engine made with a series of curved vanes on a rotating spindle. May be actuated by a current of fluid such as water or steam.
unstable isotope	A radioisotope.
uranium	(Symbol U) A radioactive element with the atomic number 92, and as found in natural ores, an average atomic weight of approximately 238. The two principal natural isotopes are uranium-235 (0.7 per cent of natural uranium), which is fissionable, and uranium-238 (99.3 per cent of natural uranium), which is fertile. Natural uranium also includes a minute amount of uranium-234. Uranium is the basic raw material of nuclear energy.
uranium enrichment	(See isotopic enrichment.)
waste, radioactive	Equipment and materials from nuclear operations which are radioactive and for which there is no further use. Wastes are generally classified as high-level (having radioactivity concentrations of hundreds of thousands of curies per gallon or cubic foot), low-level (in the range of 1 microcurie per gallon or cubic foot), or intermediate-level (between these extremes.)
watt	A unit of power equal to one joule per second.
whole body counter	A device used to identify and measure the radiation in the body (body burden) of human beings and animals: it uses heavy shielding to keep out background radiation and ultrasensitive scintillation detectors and electronic equipment.
x-ray	A penetrating form of electromagnetic radiation emitted either when the inner orbital electrons of an excited atom return to their normal state (these are characteristic x-rays), or when a metal target is bombarded with high speed electrons (these are bremsstrahlung). X-rays are always nonnuclear in origin.



## The TMI Accident, As It Really Happened

William P. Dornsife  
PA Bureau of Radiation Protection



The accident at the Three Mile Island Nuclear Station Unit 2 which occurred on March 28, 1979 has received the most notoriety and the largest amount of media coverage of any event in recent years. Although this was to date the most serious accident which has occurred in the commercial nuclear power industry, the real health hazards were minimal. In addition, the chances of a catastrophic core meltdown or other eventualities which might have increased the severity of the health risks were much less than that which has been painted by the sensationalistic media coverage which this event precipitated. This is the major reason that I feel it necessary to relate my experiences and interpretation of what really happened those first few days because the reported version caused what I feel to be a grave injustice to the people of Central Pennsylvania.

I am a nuclear engineer employed by the Pennsylvania Bureau of Radiation Protection. This agency according to the State's Emergency Plan had the prime responsibility for recommending protective action in the event of a radiological accident, or so we thought. I am also the only nuclear engineer employed by the Commonwealth, so I therefore had a very unique perspective with which to view the events as they occurred.

For the first three days, I was in a position to communicate directly with the Met Ed plant personnel and the NRC I & E inspectors who arrived on site within the first few hours. During this time I also participated in most of the meetings which occurred in the Governor's Office and the other decision making processes which were occurring at the state level. After Friday when Harold Denton arrived on site, I was assigned the task of being the onsite liaison with the NRC and had the responsibility of informing the Governor's Office and other state agencies of actions being taken or contemplated which could have offsite significance. In this position I was privy to all the information that was available to NRC. I was also able to learn firsthand from the NRC personnel who were actually involved, the unfortunate events which precipitated the unnecessary concerns about evacuation and the potential for a hydrogen explosion in the reactor vessel.

With these thoughts in mind, the following is a brief summary of (1) the radiological consequences of the accident, (2) the design, mechanical and operational errors that caused the accident, and (3) my personal involvement and the actual circumstances which caused the evacuation and hydrogen explosion concerns.

It is probably appropriate to begin the discussion of the radiological consequences of the TMI accident by noting the monitoring devices which were present in the environment around the plant before the accident and those which were added as the accident progressed. Figure 1 is a map of the area within 20 miles of the site which shows the continuous air sampling devices and the milk sampling locations which were established prior to the accident. Figure 2 shows locations of the thermoluminescent dosimeters (TLD's).<sup>1</sup> The Met Ed and

Met + Mil + mpl  Met-Ed + PA Milk Sample  PA Air Sampler 

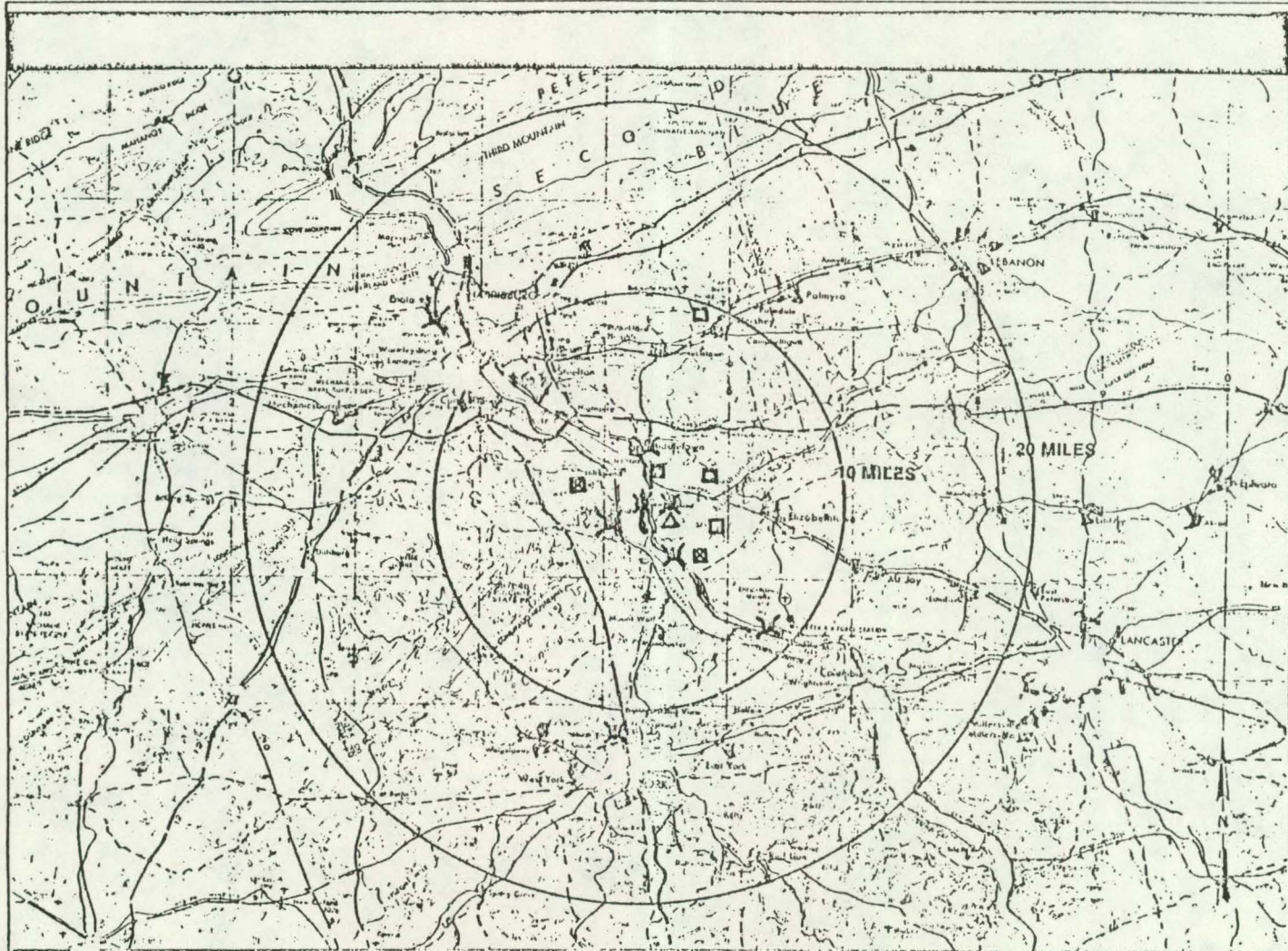

FIGURE 1: Air and Milk Sample Locations Prior to Accident

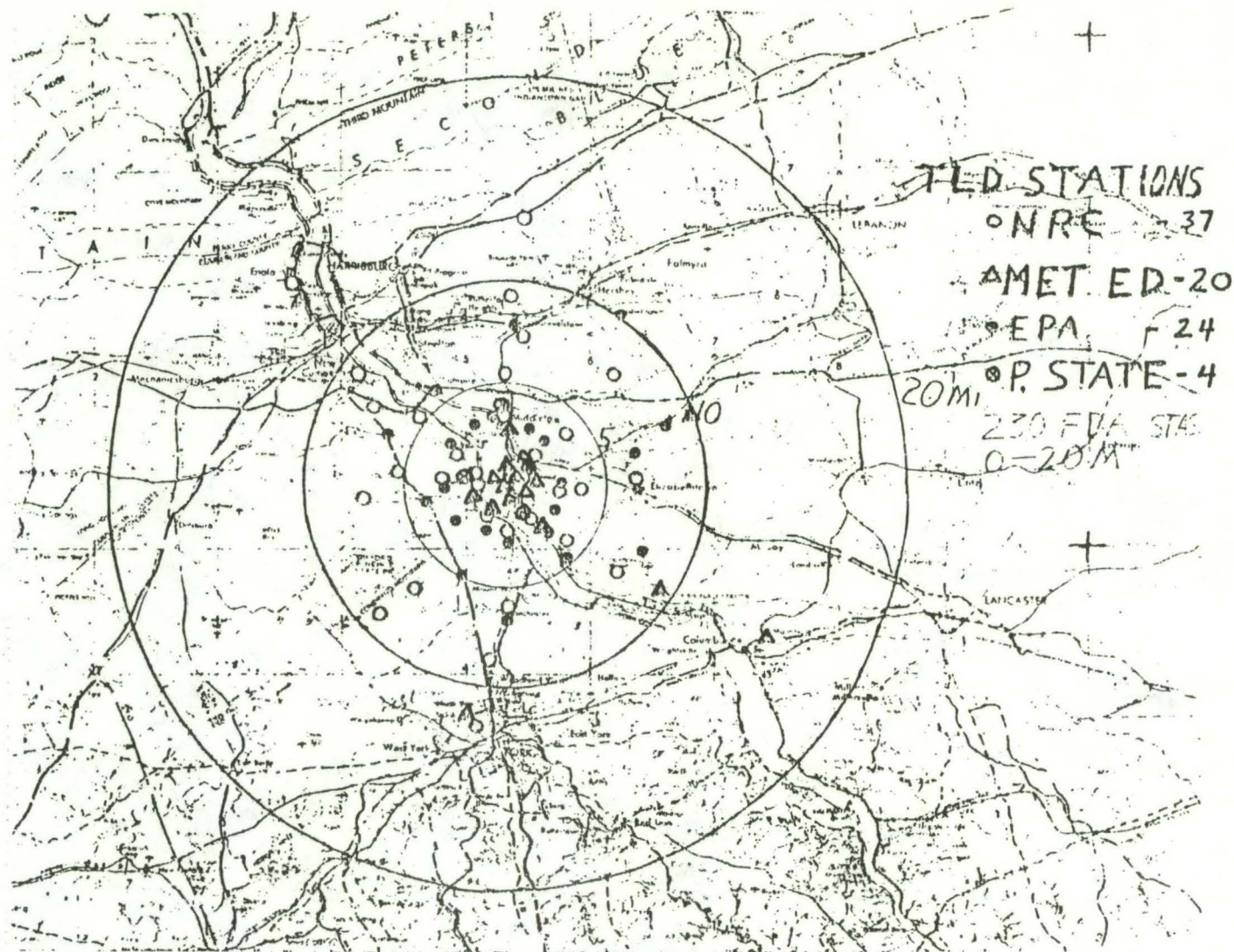

FIGURE 2: TLD Stations

Commonwealth of Pennsylvania TLD's were in place prior to the accident,<sup>2</sup> while the NRC and EPA TLD's were placed after March 30, which was also after most of the releases had occurred.

In addition to these essentially permanent monitoring locations, starting early Wednesday, mobile monitoring teams from Met Ed and the Commonwealth of Pennsylvania were performing beta gamma surveys and taking portable air samples almost continuously at various locations around the plant. These teams were supplemented later in the day on Wednesday by NRC and DOE teams which performed similar surveys up and down the east and west shore of the river on a continuous basis. As an additional supplement, helicopter teams from Met Ed and DOE periodically, and when specifically requested, performed airborne surveys primarily to quantify and define the plume of radioactive noble gases which were being released in varying amounts almost continuously over a long period of time. Numerous samples at different locations of other media such as river water, soil and vegetation were also analyzed to assure that nothing other than airborne noble gases were being released in significant quantities.

Based on the monitoring data, the NRC has estimated that about 13 million curies of radioactive noble gases and about 14 curies of radioactive iodine were released as a result of the accident.<sup>3</sup> This amount is many times that allowable by the NRC in the unit's technical specifications. Also based on the monitoring data it has been estimated that the maximum cumulative dose received by any member of the public due to noble gas emissions was about 83 millirem. This is conservative because it assumes that the individual remained at the same location, out of doors, with no clothing for a period of about one week.<sup>4</sup> The corresponding maximum possible dose to the thyroid due to inhaling radioiodine or drinking the milk with the highest found contamination<sup>5</sup> is estimated to be less than 5 millirem to a child's thyroid.

A further evaluation of the maximum cumulative doses received by the population, based primarily on the TLD data for the first week, is shown in Figure 3. These isodose curves show that out beyond about 10 miles the maximum cumulative dose was less than 1 mrem during the first week.<sup>6</sup> This compares with a natural background radiation dose in this general area of about 2 millirem over this same period.

To give a perspective on the relative magnitude of the releases over the first few days, Figure 4 is a plot of maximum individual and population dose verses time. It becomes evident from this figure that by Friday noon when the pregnant women and children advisory was given, about 90% of the individual dose would have already been received. Therefore, the evacuation in addition to being unnecessary was also not very effective.

The most comprehensive study<sup>7</sup> to date, of the health effects of the accident, was performed by a task force of radiological health professionals from the NRC, EPA and HEW. The balance of the information in this section is taken from that report, a summary of which is included as Appendix A.

The major conclusions of that report are the following:

- (1) The maximum cumulative dose that an individual located offsite might have received is less than 100 millirem.

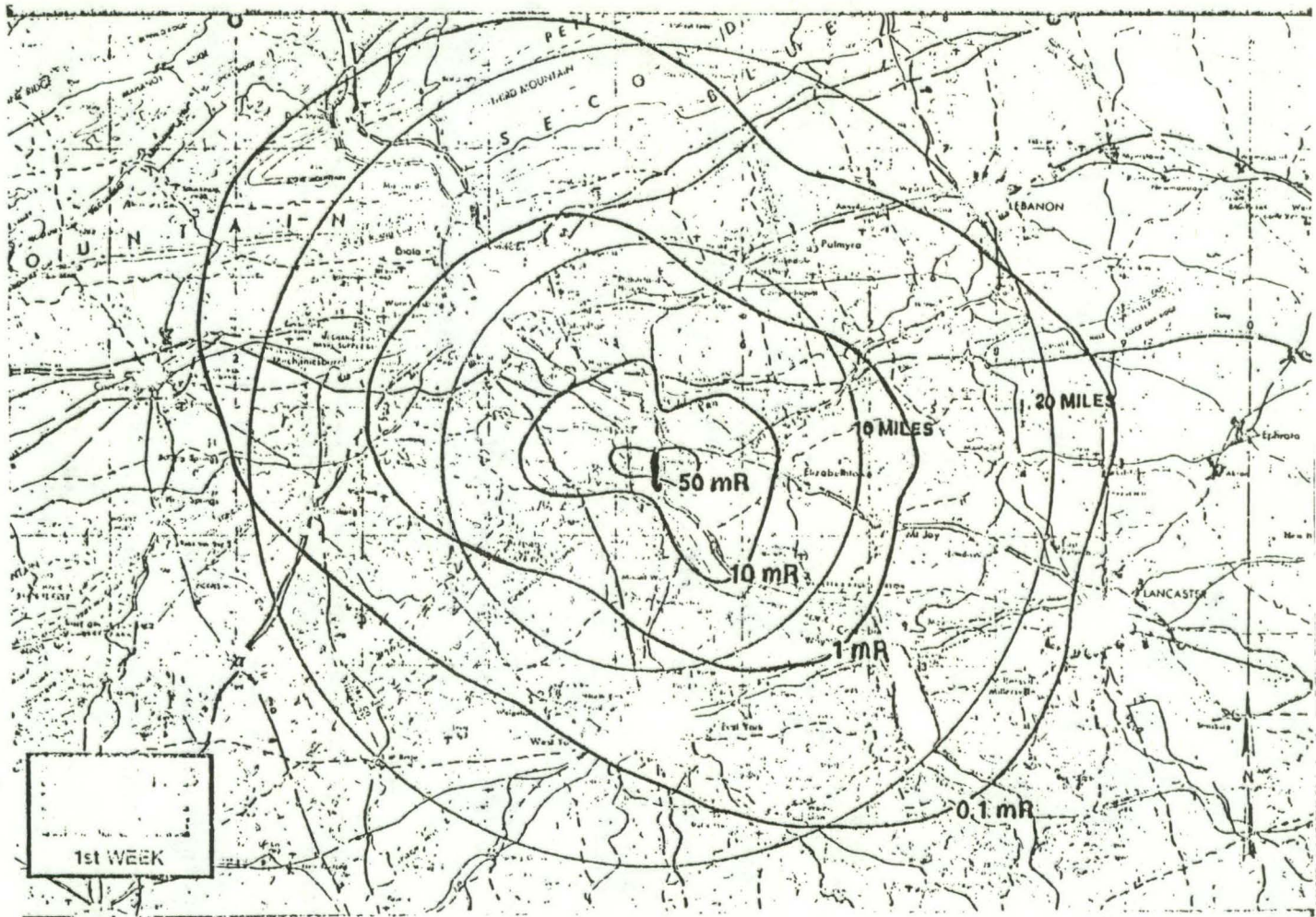

FIGURE 3: Estimated External Exposure for the First week Following the Accident from TLD Data

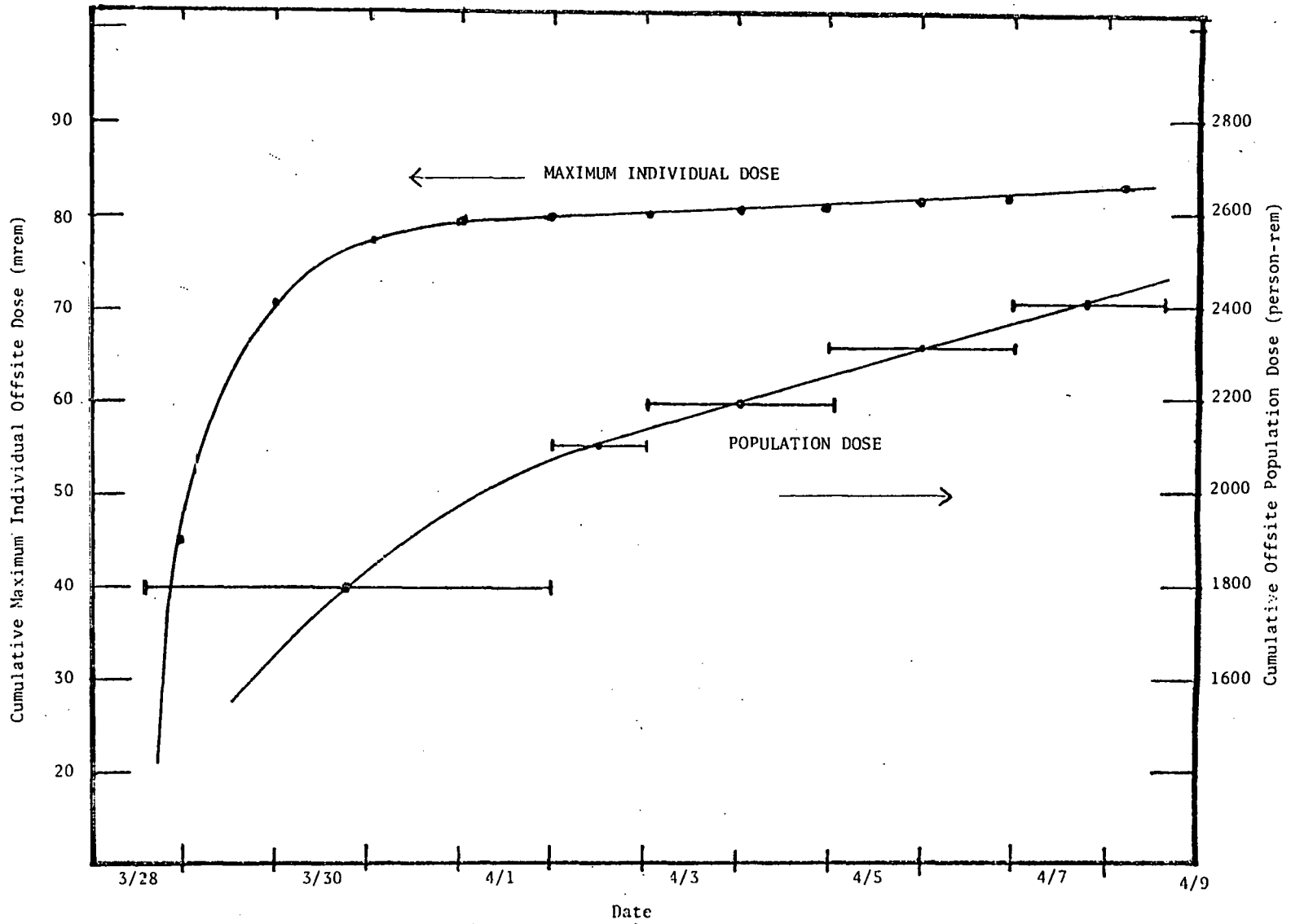

FIGURE 4: Offsite Maximum Individual and Population Dose from Noble Gas (NRC Model)

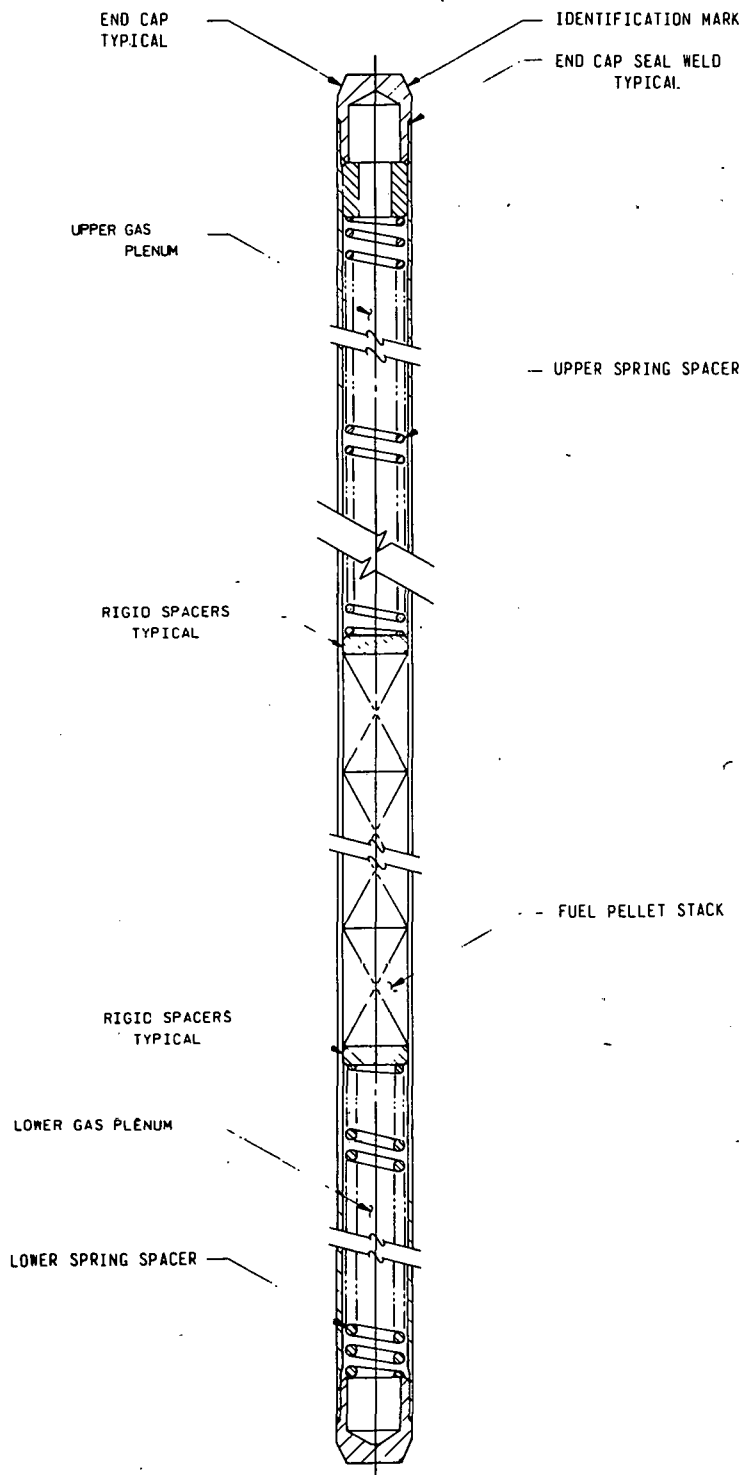

FIGURE 5

- (2) The estimate of the collective dose to the population of about 2 million within 50 miles of the site range from 1600 to 5300 person-rem, with the most likely estimate being about 3300 person-rem.<sup>8</sup>
- (3) To provide a perspective on the dose received as a result of accident, Table 1 shows a comparison with some natural background radiation exposure.
- (4) In order to estimate the number of expected health effects as a result of the accident, Table 2 gives the fatal cancer and genetic effects risk factors.<sup>9</sup>
- (5) Finally, the actual expected health effects over the lifetime of total population within 50 miles is given in Table 3. This is compared with the total expected fatal cancers in that population along with those expected from natural background radiation.

It can therefore be concluded that the radiological consequences of the accident were indeed minimal. However, the psychological stresses and anxieties which were created mainly because of the misinformation and the sensationalistic media coverage could have produced some very adverse effects on the population, many of which will be very difficult if not impossible to quantify.

The design philosophy for a nuclear power plant requires the use of several independent barriers, all of which must be violated to allow the release of significant quantities of fission products.<sup>10</sup> In the case of the TMI accident most of these barriers were at least partially breached for limited periods of times for various reasons as follows:

- (1) The first and probably most important barrier is the fuel rods as shown in Figure 5. This barrier is a combination of the ceramic uranium oxide fuel pellets along with the zirconium alloy cladding in which they are encased. In order for a large fraction of the fission products which become trapped in the fuel pellet matrix to escape, the fuel pellet must melt and the cladding must be breached. In addition, during operation a small fraction of the more volatile fission products such as noble gases and iodine migrate out of the fuel pellet and become trapped in the gaps at the end and between the pellets. Therefore if only the cladding were to fail this "gap activity" would be released. This was primarily what happened during the accident. Due mainly to an operational error and a misinterpretation of the instrument indications, the operators did not maintain sufficient inventory in the reactor coolant system and the core eventually became uncovered. This caused some of the fuel rods to increase in temperature to a point where a zirconium metal-water reaction occurred. This reaction eventually caused a breach of the cladding and generated a significant amount of hydrogen.
- (2) The second barrier to the release of substantial amounts of fission products, assuming the fuel rod barrier is breached, is



TABLE 1

Comparison of TMI Accident Dose with Natural Background Radiation

Estimates of natural background radiation levels at various locations in the U.S.

<u>Location</u>	<u>Annual Dose Rate mrem/yr</u>			<u>Total</u>
	<u>Cosmic Radiation</u>	<u>Terrestrial Radiation</u>	<u>Internal Radiation</u>	
Atlanta, Georgia	44.7	57.2	28	130
Denver, Colorado	74.9	89.7	28	193
Las Vegas, Nevada	49.6	19.9	28	98
Harrisburg, PA	42.0	45.6	28	116

Living in Denver, Colorado compared to Harrisburg, PA - + 80 mrem/yr

Living in a brick house instead of a wood frame house - + 14 mrem/yr

Variation in natural background radiation within 50 miles of TMI -  
100 to 130 mrem/yr

Radiation dose delivered as a result of TMI accident

Individuals remaining out of doors at location of highest estimated  
offsite dose - less than 100 mrem

Average dose to a typical individual within 50 miles of the site - 1.5 mrem  
10 miles of the site - 8 mrem

Population dose within 50 miles of site - 3300 person-rem

Natural background radiation dose during the same 11 day period above

Average background dose to typical individual - 3.5 mrem

Population background dose within 50 miles - 7500 person-rem

TABLE 2  
Risk Factors for Low-Level Radiation Exposure

RADIATION-INDUCED CANCER MORTALITY ESTIMATED IN THE 1972 BEIR REPORT (3)

	1972 BEIR Report Estimates		Derived Risk	
	Annual number of deaths resulting from exposure of the U.S. population to a radiation dose rate of 0.1 rem [100 millirem] per year <sup>(a)</sup>		Number of Cancer Deaths per 10 <sup>6</sup> person-rem <sup>(b)</sup>	
	Absolute Risk Model	Relative Risk Model	Absolute Risk Model	Relative Risk Model
Leukemia	516	738	26	37
Other Fatal Cancers				
Assumption A: <sup>(c)</sup>	1210	2436	61	123
Assumption B: <sup>(d)</sup>	1485	8340	75	421
Total (Range) <sup>(e)</sup>	1726-2001	3174-9078	87-101	160-458
Nominal Range <sup>(f)</sup>	1700-2000	3200-9100	90-100	160-460
	Geometric mean (95 x 310) <sup>1/2</sup>		= 200 (172)	

(a) 1967 U.S. population = 197,863,000. Collective Dose Rate = (198 x 10<sup>6</sup> people) x (0.1 rem/yr) = 19.8 x 10<sup>6</sup> person-rem/year. From Table 3-3 (Relative Risk and Table 3-4 (Absolute Risk) of the 1972 BEIR Report (3) pp. 172-173.

(b) 1972 BEIR Values (Cancer deaths/year) divided by the collective dose rate of 19.8 [10<sup>6</sup> person-rem]/year.

(c) Assumption A: 30-year period of elevated risk following irradiation.

(d) Assumption B: Lifetime period of elevated risk following irradiation.

(e) Low estimate = Leukemia Risk + Assumption A for other fatal cancers.

High estimate = Leukemia Risk + Assumption B for other fatal cancers.

(f) Preceding values rounded to two significant figures.

ESTIMATES OF GENETIC EFFECTS OF LOW-LEVEL IONIZING RADIATION

Disease Classification	Natural Incidence (per 10 <sup>6</sup> live births)	Effects per 10 <sup>6</sup> live births <sup>(a)</sup> of 5 rem per generation <sup>(b)</sup>		Estimated Risk per 10 <sup>6</sup> person-rem <sup>(c)</sup>	
		First Generation	Equilibrium	First Generation	Equilibrium
Dominant diseases	10,000	50 to 500	250 to 2500	6 to 60	30 to 300
Chromosomal and recessive diseases	10,000	relatively slight	very slow increase	relatively slight	very slow increase
Congenital anomalies	15,000				
Anomalies expressed later	10,000	5 to 500	50 to 5,000	0.6 to 60	6 to 600
Constitutional and degenerative diseases	15,000				
TOTAL	60,000	60 to 1000	300 to 7500	7 to 120	36 to 900
Risk per 10 <sup>6</sup> people	1,200 <sup>(d)</sup> /year				
		Geometric Mean		(36 x 900) <sup>1/2</sup> = 200 (180)	

(a) From the 1972 BEIR Report (3), Table 4 p. 57 which is believed to be erroneously titled. This table, like the preceding tables 2-3 pp. 54-55, is believed to be for a population of one million "live births" not for a population of one million. The range of values corresponds to assumed doubling doses between 20 rem (high values) and 200 rem (lower values).

(b) A generation is assumed to be 30 years.

(c) Risk per 10<sup>6</sup> person-rem = (cases/10<sup>6</sup> live births) x (30 years/5 rem) x (4 x 10<sup>6</sup> live births/year per 2 x 10<sup>8</sup> people) = 0.12 x cases/10<sup>6</sup> live births.

(d) Cases/10<sup>6</sup> live births x (4 x 10<sup>6</sup> live births per year/ 2 x 10<sup>8</sup> people).

TABLE 3  
PROJECTED POTENTIAL HEALTH IMPACT OF THE THREE MILE ISLAND ACCIDENT  
TO THE OFFSITE POPULATION WITHIN 50 MILES

Effect	Estimated Number who would normally develop effect	Potential Impact of Natural Background Radiation	Potential Lifetime Impact of Population Dose from the TMI Accident from March 28, 1979 through April 7, 1979	
			Range <sup>(a)</sup>	Central Estimate <sup>(b)</sup>
Fatal Cancers	325,000 <sup>(c)</sup>	1,700 - 9,000 <sup>(d)</sup>	0.15 - 2.4 <sup>(e)</sup>	0.7
Non-Fatal Cancers	216,000 <sup>(f)</sup>	1,700 - 9,000 <sup>(d,g)</sup>	0.15 - 2.4 <sup>(c,f)</sup>	0.7
Genetic Effects				
first generation	78,000 <sup>(h)</sup>	60 - 970 <sup>(i)</sup>	(0.01 - 0.64) <sup>(j)</sup>	-
all future generations	-		0.05 - 4.8 <sup>(k)</sup>	0.7
All Health Effects			0.4 - 10 <sup>(l)</sup>	2.0 <sup>(l)</sup>

Footnotes

- (a) This represents the extreme range of health effects estimates considering both the range of the collective dose estimates and the range of the estimates of the risks of low-level ionizing radiation as estimated in the 1972 BEIR Report (3).
- (b) The central estimate is based upon taking the geometric mean (square root of the product) of the upper and lower bounds of the dose-to-health-risk conversion factors from Table 4-1 and multiplying this by the mean estimate of the population dose (3,300).
- (c) Based upon the American Cancer Society projection that the risk of cancer death is 0.15 (0.15 x 2,164,000 = 324,600).
- (d) Based upon multiplying the annual rates in Table 4-7 by 70 years, the mean life span.
- (e) Based upon multiplying the lower range estimate of the population dose (1,600 person-rem) by the lower range of the absolute radiation-induced cancer risk ( $90 \times 10^{-6}$ ) and the upper range estimate of the population dose (5,300) by upper range of the relative radiation-induced cancer risk ( $460 \times 10^{-6}$ ).
- (f) Based upon the difference between the American Cancer Society projection of the risk of getting cancer (0.25) and the risk of dying of cancer (0.15). The value given is the product of this difference (0.25 - 0.15 = 0.10) and the size of the population (2,164,000).
- (g) Based upon the assumption that there are twice as many cancers as there are cancer fatalities.
- (h) Based upon the natural annual incidence of genetic effects (1,200 per year per  $10^6$  population) from table 4-2 times an assumed reproductive period of 30 years.
- (i) Based upon multiplying the risk to the first generation from table 4-2 by an assumed reproductive period of 30 years and by the natural background dose rate of 270,500 person-rem per year.
- (j) Based upon multiplying the lower bound of first generation risk ( $7 \times 10^{-6}$ ) from Table 4-2 by the lower bound of the collective dose estimate (1,600 person-rem) and multiplying the upper bound of the first generation risk ( $120 \times 10^{-6}$ ) from Table 4-2 by the upper bound of the collective dose estimate (5,300 person-rem). The first generation risk is included in the risk to all generations and therefore, should not be separately added into the total.
- (k) Based upon the procedure described in (j) but using the equilibrium risk bounds rather than the first generation risk.
- (l) This is done for the convenience of providing an estimate of the total potential health impact. Technically, the effects are not equivalent and cannot be added.

the reactor coolant system. An elevation and plan view of this system is shown in Figure 6. This barrier was breached during the first two hours of the accident due to a mechanical failure of the power operated relief valve. This valve, which is located on the pressurizer, failed to reclose after it had opened on increasing pressure in the system following the initial turbine trip and loss of feedwater transient.

- (3) The final barrier to the release of radioactive material in the case of an accident is the reactor containment building. This four foot thick, reinforced concrete, steel lined building is shown in Figures 7 and 8. This barrier was partially breached for about the first four hours of the accident due to a failure of the building to isolate. Because of a design deficiency, the only isolation signal provided was a high pressure isolation at 4 psig which was not achieved until after substantial fuel cladding damage had occurred. However, due to the fact that most of the fission products which escaped the reactor building entered the auxiliary building, and since the exhaust ventilation system from this building passes through high efficiency particulate and iodine filters, the only fission products which escaped into the environment in substantial quantities were the noble gases.

In addition to these previously mentioned barriers, there are several safety related, high quality, redundant systems which are primarily designed to maintain the inventory in the reactor coolant system and keep the core cool in the event of any type of a loss of coolant accident.<sup>11</sup> Again looking at Figure 8, the most important of these systems are the high pressure injection/makeup system for small breaks where the pressure can be maintained, and the low pressure injection/decay heat system for larger breaks where the pressure rapidly drops. In addition to these active systems there are the core flood tanks which will passively inject water directly into the reactor vessel when the pressure goes below about 600 psig.

With this basic discussion of the design philosophy of a nuclear power plant as background and referring to Figure 8, the following is a very brief description of the major causes of the accident and its subsequent progression. (A detailed chronology of the first 16 hours of the accident before a stable condition was finally achieved is included as Appendix B).

At about 4:00 AM on Wednesday, March 28, 1979 the plant was operating normally at 97% power when both feedwater pumps tripped which in turn caused the turbine to trip. This trip is considered to be an anticipated transient which the plant was designed to handle with insignificant consequences. This sudden decrease in heat removal capability caused a very fast increase in pressure and temperature in the primary system. This in turn led to the opening of the power operated relief valve on the pressurizer followed very soon after by a reactor trip on high pressure. With the reactor trip the fission process in the core was stopped and the heat generation rate dropped to the decay heat rate, causing the pressure and temperature in the primary system to decrease. At this point the first unexpected problem occurred, the power operated relief valve failed to reclose. Unfortunately, the indication to the operator, which was only the electrical signal to the valve, indicated that it

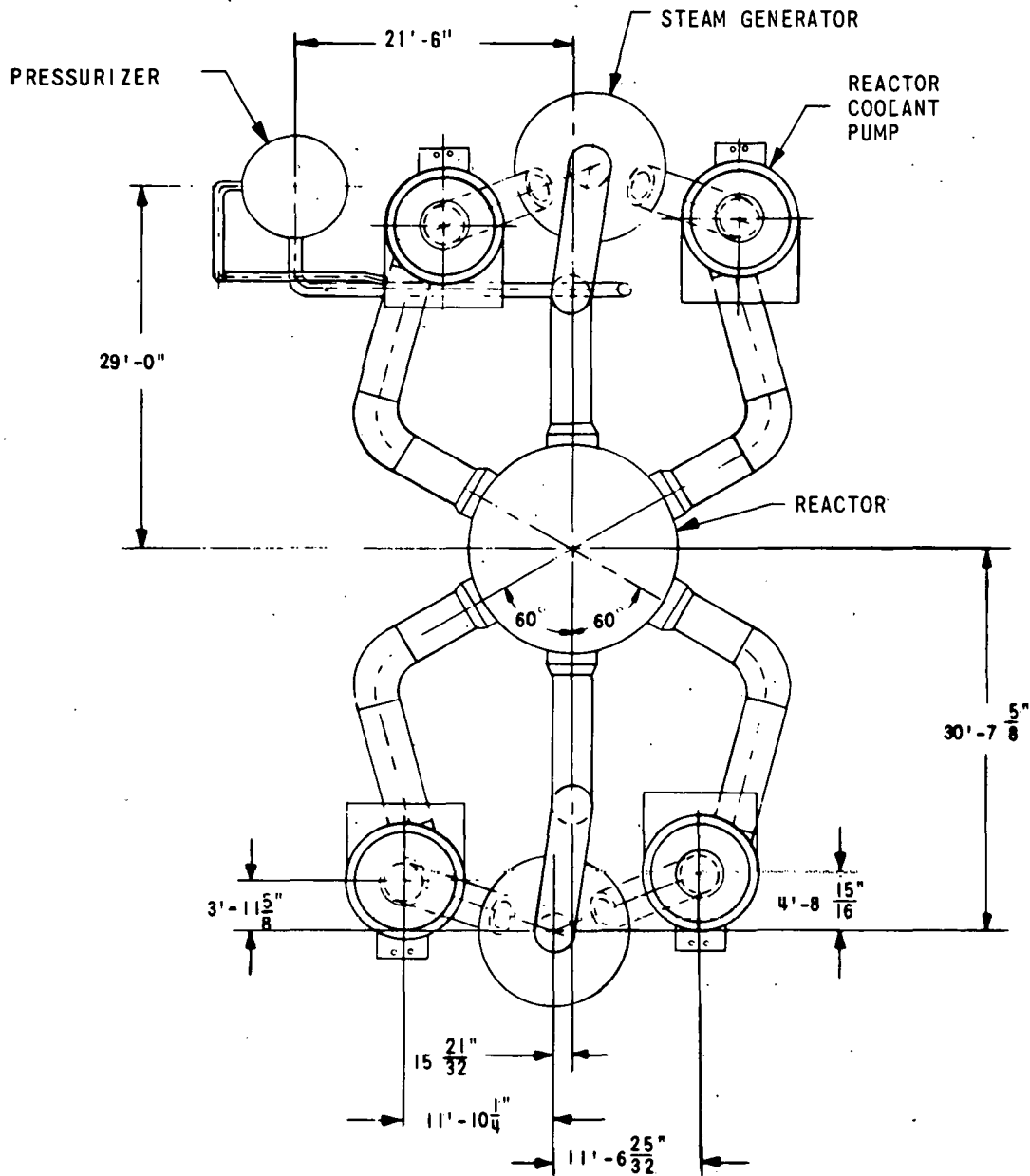

REACTOR COOLANT SYSTEM ARRANGEMENT - ELEVATION  
 THREE MILE ISLAND NUCLEAR STATION UNIT 2



FIGURE 6-a

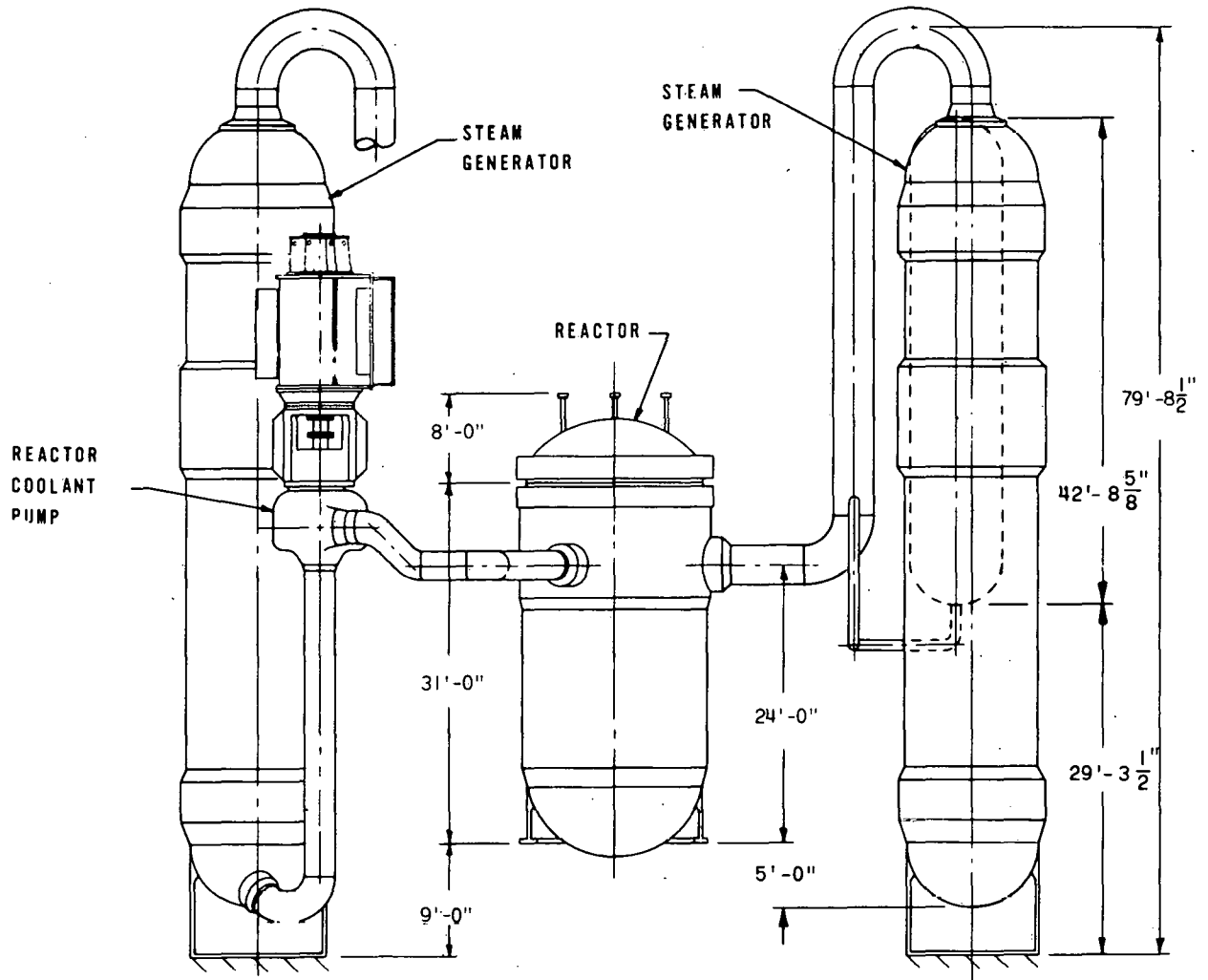
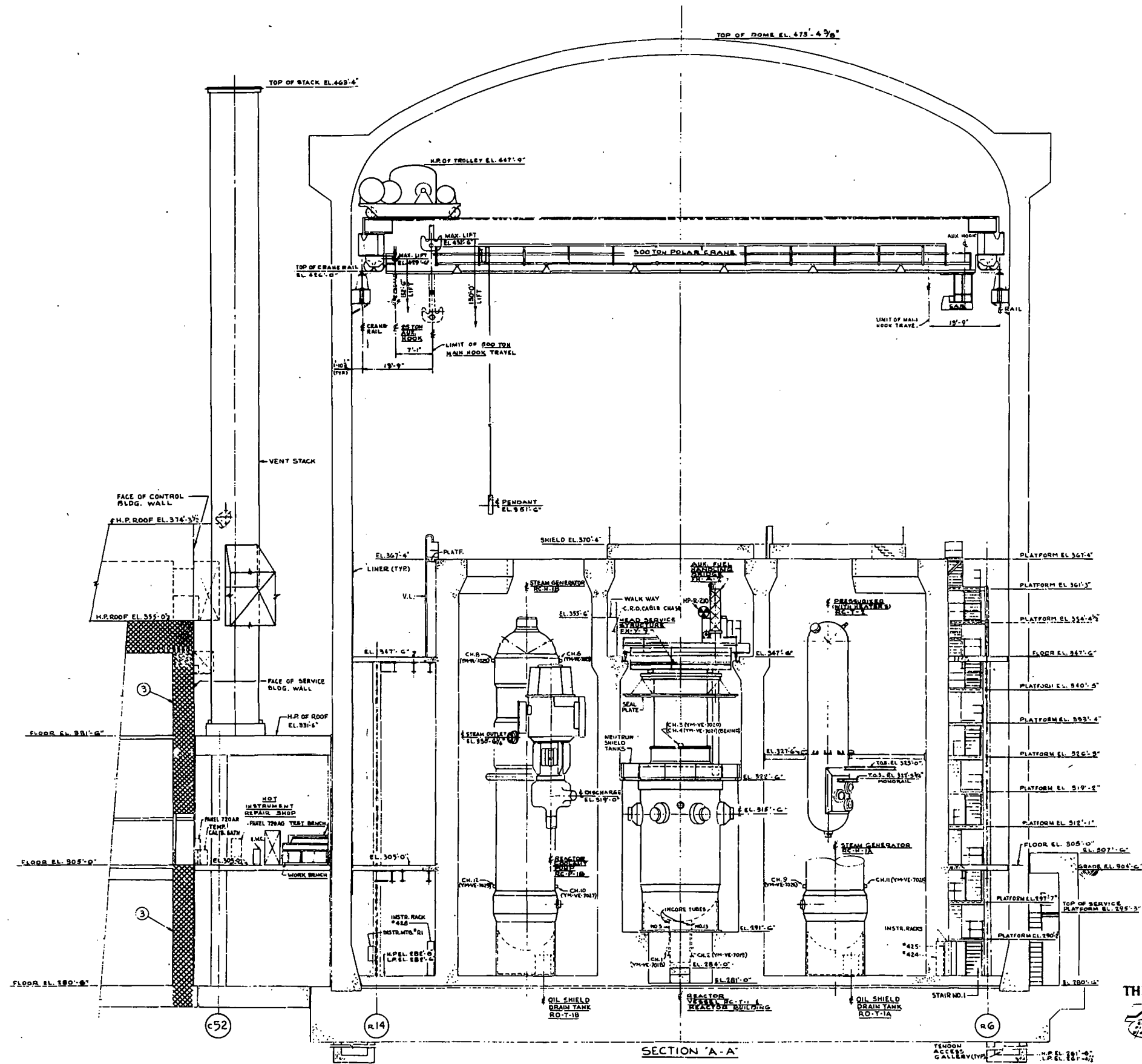

FIGURE 6-b



**NOTES**  
 1. C-1 THRU 5, 7 & 9 THRU 12 REPRESENT VIBRATION MONITORING SENSORS.

**LEGEND**  
  
 = FIRE RATED WALL  
 ○ = HOURLY FIRE LIMIT

WORK THIS DRAWING WITH DWGS. 2050, 2061, 2062 & 2064.

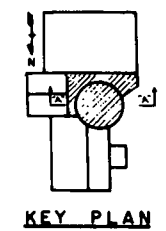

**REACTOR BUILDING SECTION A-A  
 THREE MILE ISLAND NUCLEAR STATION UNIT 2**



**FIGURE 1.2-6  
 AM. 58 (8-26-77)**

**FIGURE 7**

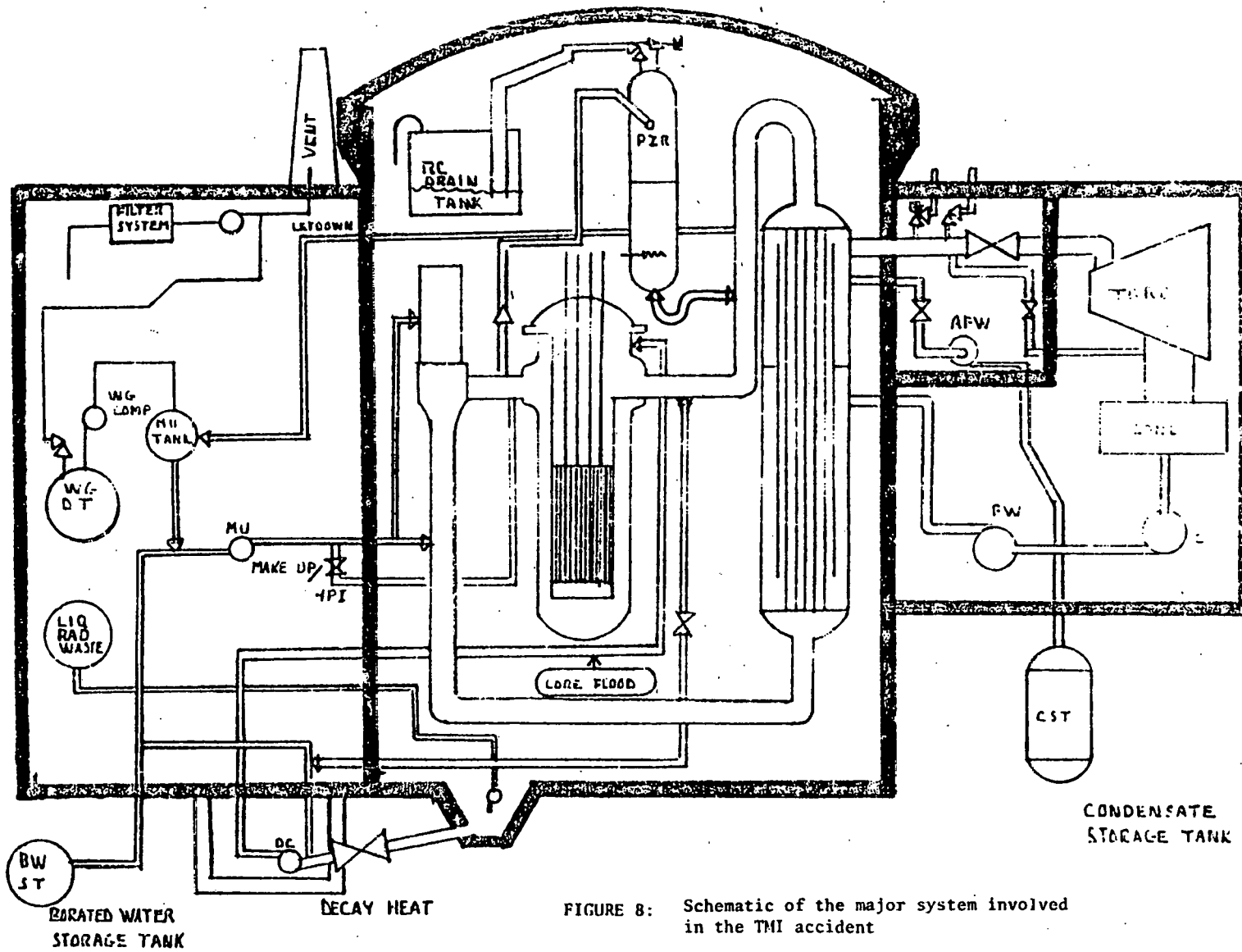

FIGURE 8: Schematic of the major system involved in the TMI accident



had reclosed. This mechanical failure in essence caused a small loss of coolant accident which was not recognized by the operator until much later into the sequence.

In addition to this mechanical failure, and as a result of an operational surveillance error, the emergency feedwater system, which started automatically upon the loss of normal feedwater, was blocked out by two valves which were closed in violation of the plant's technical specifications. This condition persisted for about 8 minutes until finally recognized by the operator after the steam generators had boiled dry. This temporary lack of feedwater to the steam generator by itself would not have led to the subsequent uncovering of the core. However, it did cause the transient to be much more severe, contributing to the misleading indications of pressurizer level. This level indication eventually led the operators to believe they had a full reactor coolant system and caused them to throttle back on the high pressure injection/makeup pumps which had been injecting at full flow. Had these pumps been allowed by the operators to continue injecting full design flow, the decrease of inventory in the reactor coolant system would never have occurred. This operational error therefore was the primary cause of the eventual uncovering of the core.

Meanwhile, the water which was being relieved through the stuck open relief valve was filling the reactor coolant drain tank which eventually spilled its contents to the floor of the reactor building. Due primarily to the design deficiency of a lack of diverse signals for reactor building isolation, a significant amount of this water was automatically pumped over to tanks in the auxiliary building. This breach of containment, along with a suspected primary to secondary leak in one of the steam generators, was initially thought to be the primary release path of noble gases and possibly iodine from the plant. However, it was much later determined that the primary release path was normal and/or abnormal leakage through the letdown and makeup system and the gaseous radwaste system, the operation of which was required to maintain a stable cooling mode.

The loss of reactor coolant inventory, combined with insufficient makeup, continued for about the first 2 1/2 hours until finally an isolation valve upstream of the power operated relief was shut by the operator, terminating the loss of coolant accident. In the meantime, the operator had tripped all reactor coolant pumps due to excessive vibrations. This loss of forced reactor coolant flow, combined with the loss of coolant inventory, led to the uncovering and heatup of the core. The core was at least partially uncovered for about 1 1/2 hours until the power operated relief valve was isolated allowing the pressure in the system to increase above saturation. While the core was uncovered a zirconium metal-water reaction occurred which generated significant amounts of hydrogen and caused the release of significant amounts of fission products from the fuel rods. It is important to note that during this time, if the operators would have had sufficient indication to determine that the core was uncovered, they would have increased the high pressure injection/makeup flow to full design flow. This would have quickly recovered the core preventing substantial fuel damage from occurring.

At about 6:40 AM several in-plant radiation monitors began to alarm, making it obvious that severe radiological problems were beginning to develop.

Based on this situation, Met Ed declared a site emergency and began to notify the appropriate offsite agencies according to their emergency plan. It was at this point that I first became involved in the accident. Being the Bureau's duty officer, at about 7:05 AM I was called by PEMA (Pennsylvania Emergency Management Agency) and informed that a site emergency had been declared and that I was to call the plant control room for technical details in accordance with our emergency plan. Upon calling the plant I was informed that they had suffered a small loss of coolant accident which had been terminated. They also told me that the plant conditions were now stable and no offsite releases were occurring. I then called the other key members of the Bureau and upon arriving in our office they established an open line with the control room at about 7:30 AM, again in accordance with our emergency plan. At about this time a general emergency was declared due to increasing radiation levels in the reactor building.

During the entire first few days we retained an open line with the plant control room. At all times we felt that Met Ed was being candid and giving us all the available information that they had on plant status and radiological monitoring. This information was being confirmed later that morning by NRC I & E personnel who arrived from the King of Prussia Office.

Also about this time we were informed by Met Ed that their initial dose assessment calculation indicated the possibility of a 10 rem/hr dose rate offsite near Goldsboro. This calculation was based on the radiation levels in the reactor building, and assumed a 50 psig pressure in the building (the actual pressure at this time was about 2-4 psig) and the release of a reference mix of radioisotopes. This immediately alerted us to the possibility of an evacuation and we called PEMA to alert York County. A few minutes later radiation surveys downwind of plant verified that no radiation levels above background were detectable. This, combined with the low pressure in the reactor building prompted us to call off this alert and the appropriate agencies were so notified.

By about 10:00 AM radiation levels in the range of 1-3 mrem/hr were first detected immediately offsite by the utility. This prompted us to send out a state monitoring team which verified the readings. For the remainder of Wednesday, surveys performed by teams from the state, utility, NRC and DOE confirmed that offsite levels of radiation were in the range of 1-10 mrem/hr ( $\beta - \gamma$ )<sup>12</sup> near the site. Occasionally higher levels were observed onsite, in the plume, and in relatively stagnant pockets.<sup>13</sup> This was primarily caused by the meteorological conditions during the first few days of low wind speed and variable direction which resulted in very little dispersion.

Meanwhile at the plant, the operators were attempting various means of keeping the core cool and trying to establish a more stable cooling mode. There was sufficient evidence at this time to indicate that voids were present in the reactor coolant system and that significant fuel damage had occurred. The attempted methods varied from allowing the pressure to increase in order to collapse the voids and start a reactor coolant pump; to trying to depressurize in order to allow injection of the core flood tank in an attempt to assure the core was covered, and then trying to establish the normal cold shutdown cooling method using the decay heat removal system. Due mainly to the large amount of voiding in the reactor coolant system and the long period of time required to refill the system, these attempts were unsuccessful in establishing

a stable cooling mode. However, they were successful in keeping the core covered and preventing further fuel damage.

Another event which occurred at about 2:00 PM, the possible significance of which went unnoticed or unrecognized by the operators, was a 28 psig pressure spike in the reactor building which is thought to be due to a localized hydrogen burn or explosion. The recognition of this event about a day and a half later led to an increased awareness on the part of the NRC in Washington to the possibility of further hydrogen or additional unknown problems.<sup>14</sup>

Finally, at about 8:00 PM Wednesday evening the operators were able to collapse the voids in the "A" loop and start a reactor coolant pump to establish forced circulation, thus finally establishing a stable cooling mode. It should be noted that although there was still a significant hydrogen/steam/noble gas void at the top of the reactor vessel, it was not interfering with the forced cooling and therefore this was a stable condition. In addition, because of the continuing operating of the letdown/makeup system, this gas void was slowly being reduced by dissolving in the reactor coolant system and being vented into the makeup tank.

After leaving the office a few hours earlier, I arrived back at about 8:00 AM on Thursday morning and immediately decided to go down to the site to get a clearer picture of how the situation was progressing. Upon arriving at the Observation Center, which is right across the river to the East of the plant, I interfaced directly with the Met Ed and NRC personnel who were there mainly coordinating the offsite monitoring effort. Throughout the day offsite radiation levels appeared to be trending downward with many stations approaching background levels. Average radiation levels downwind near the site were in the range of 1-3 mrem/hr with occasional higher levels onsite and directly in the plume.

While at the site on Thursday, I vividly remember seeing reports of radiation levels taken by helicopter above the plant vent as high as 3000 mrem/hr ( $\beta - \gamma$ ). This is one of the major reasons why, on Friday morning when the 1200 mrem/hr ( $\beta - \gamma$ ) reading above the vent was reported, we were not overly concerned about the eventually offsite doses or need for protective action.

Our major concern at this time was the need for locating the source of the releases and controlling them, which I expressed to Met Ed management and they concurred. I went home that evening feeling that the worst was over and all that remained was a very difficult clean-up operation. Little did I know that the next morning all hell was to break loose almost completely unnecessarily.

Shortly after arriving in the office at about 8:00 AM on Friday morning, we received information from the plant indicating that in the process of venting the makeup tank a release of noble gas had occurred. A helicopter which had been monitoring the release had detected a momentary level of 1200 mrem/hr ( $\beta - \gamma$ ) about 150 feet directly above the plant vent. Utility and NRC monitoring teams downwind had detected maximum levels of about 20-25 mrem/hr ( $\beta - \gamma$ ) immediately offsite near the Observation Center. These maximum levels were of very short duration and were decreasing rapidly to less than 1 mrem/hr. In addition, we had sent out a state monitoring team to perform surveys in the

vicinity of the plant. They were also taking readings near the Observation Center and saw a maximum of about 17 mrem/hr ( $\beta - \gamma$ ) for a short duration, essentially confirming the utility and NRC data. We were therefore confident that no protective action was required as a result of this release.<sup>15</sup>

About 9:00 AM, we received a notification from PEMA that they had received a telephone call from NRC headquarters in Washington recommending an immediate evacuation out to 10 miles, and were requesting our assessment of the situation. We told them that, based on the information that we had, there was no reason for any protective action, and that we would confirm our assessment and call them back. We immediately called NRC headquarters in Washington to find out the reason for their evacuation recommendation. I personally participated in the very frustrating conversation which followed. I informed them of our assessment of the situation, to which they did not seem to disagree or even take serious note. About all we could get out of them was that the recommendation was made by top management at NRC, the specific source of which they would not provide. After hanging up in frustration, we contacted our monitoring team and the plant to determine if the situation had changed significantly. After confirming the situation was stable and radiation levels were still decreasing, we attempted to call PEMA to confirm our initial assessment that no protective action was required. Unfortunately the local radio stations were already making announcements to prepare to evacuate. The excitement which was created by these announcements had completely overloaded the telephone system and we were not able to contact PEMA by phone. Therefore, it was decided that I should go to PEMA headquarters and Tom Gerusky, the director of our bureau, should go to the Governor's Office (both within reasonable walking distance) with the recommendation that no protective action be taken. In the meantime, Chairman Hendrie of the NRC from Washington had contacted Governor Thornburgh and had recommended a "take cover" within 10 miles of the plant, which was subsequently implemented.

Later that morning in another telephone conversation with the Governor, Chairman Hendrie, under the false assumption that substantial releases were occurring and were likely to continue in the future, stated almost matter of factly that if he had a pregnant wife and preschooler in the area, he would probably want them out. Thus came the recommendation for a precautionary advisory that pregnant women and children<sup>16</sup> leave the area within 5 miles of the plant. This advisory was later that morning given to the public by the Governor.

I was much later to learn firsthand from the people who were directly involved, the unfortunate series of misunderstandings that led to that Friday morning recommendation to evacuate. This event more than anything led to the escalation of a minor release into a full blown crisis, which continued for many days. A re-creation of those events are as follows:

Early Friday morning the plant operators, suspecting that leakage in the waste gas system was a major contributor to the release that were occurring, had been periodically shutting the vent on the makeup tank.<sup>17</sup> The pressure in the tank had slowly built up to the liquid relief setpoint and was relieving, thus threatening the normal recirculation mode of the makeup and reactor coolant pump seal water system.<sup>18</sup> The operators had decided to open the vent on the makeup tank to allow the continuation of this normal mode of

operation. About an hour after the vent was opened, radiation levels of 1200 mrem/hr ( $\beta$  -  $\gamma$ ) were measured from a helicopter about 150 feet above the plant vent. This was essentially the information that we received from the plant shortly after 8:00 AM.

Meanwhile, at the NRC Incident Response Center (IRC) in Bethesda, Md., an open line had been earlier established with the Unit 2 control room and they were being relayed information from an NRC I & E inspector. On Friday morning based on erroneous information, it was believed by the NRC in the IRC that the waste decay tanks were full. They therefore thought that the venting from the makeup tank was being compressed into the waste gas decay tanks, and these tanks were periodically relieving their contents at a discharge point downstream of the auxiliary building filters.<sup>19</sup>

Based on the above erroneous assumptions and using an assumed reactor coolant radioisotope concentration, NRC personnel in the IRC made a rough, conservative calculation which indicated that given these assumed circumstances the estimated offsite dose would be about 1200 mrem/hr. At about the same time this estimate was being given to the people in charge of the IRC,<sup>20</sup> the helicopter measurement of 1200 mrem/hr came in over the open line from the plant. Neglecting to verify the 1200 mrem/hr measurement and assuming it to be an offsite measurement, it was decided to recommend a downwind evacuation out to 10 miles. Unfortunately this recommendation was given directly to PEMA, completely bypassing our Bureau, which was supposed to have this responsibility. Fortunately it was never carried out.<sup>21</sup>

A short while later when the IRC finally realized that this 1200 mrem/hr level was directly above the plant vent, they performed another very conservative calculation which indicated that if this level persisted for a long period of time the offsite dose would be about 120 mrem/hr. This additional erroneous estimate, it is believed, then became the basis for Chairman Hendrie's recommendation to "take cover" 10 miles downwind.

The other major concern, which began on Friday and which probably caused even more unnecessary consternation than the misconceived evacuation, was the possibility of radiolysis<sup>22</sup> occurring in the reactor coolant system. It was first thought that the hydrogen and oxygen, which under certain conditions can be generated by radiolysis, was slowly increasing the size of the bubble in the reactor vessel thus eventually interferring with the forced cooling of the core and requiring the use of high pressure safety injection to keep the core covered. Later an even greater concern arose about the possibility of radiolysis. This had to do with the possible generation of oxygen having the potential to eventually cause an explosive gas mixture in the reactor vessel, which if detonated could have led to a core disruption accident.

As it turns out, all these concerns were completely groundless. It was not physically possible for any radiolysis to have occurred in the reactor coolant system due to the existence of a very large overpressure of hydrogen which totally inhibited this reaction.<sup>23</sup> In simple terms this means that the primary basis for all the speculation about possible core meltdown and precautionary evacuations which occurred over that first weekend did not even exist.

When these concerns about radiolysis first arose, most of the technical people involved, after careful consideration, did not believe that it presented a real problem. From my own experience with pressurized water reactors, I knew that a small excess concentration of hydrogen was maintained in the primary system to scavenge oxygen and prevent radiolysis. Most of the knowledgeable people that I discussed the problem with concurred that it was probably a very unrealistic assumption. However, there were a few NRC staff people who were perpetuating this concern. And unfortunately until the bubble was eventually dissipated by a deliberate venting of the reactor coolant system, this was considered to be the initiator of the worst case scenario for accident planning purposes.<sup>24</sup>

In my opinion, the reason for this error was that the people who were working on this problem in Washington were given the wrong assumptions concerning the conditions in the system. It would later be discovered that the radiolysis rate was calculated at atmospheric pressure,<sup>25</sup> while the real condition in the system was a pressure of about 1000 psig saturated with hydrogen.

It is unfortunate, but not surprising that the NRC would continue to use these most pessimistic and unrealistic assumptions in their discussions about possible scenarios. In my opinion, this was primarily due to the fact that the organization of the NRC was designed specifically to review and license nuclear power plants, in which they do a credible job. For this reason, they typically have groups of experts who review very specific areas. In this particular case, however, they were completely out of their element. These various groups of experts were typically predicting the worst in their particular area. Unfortunately, there were very few NRC personnel with a good overall working knowledge of the plant to sort out this sometimes conflicting and pessimistic information.

It is not surprising that these circumstances in turn led to obvious problems for the media in attempting to report the story. My first involvement with the media came early Wednesday morning while fielding questions at the first press conference. During this exchange I became painfully aware that much of the technical information the media was seeking was completely over their heads. This lack of technical knowledge which was evident throughout the entire episode, led to some misunderstandings and a tendency to get bogged down on minor details thus preventing the complete details from becoming known.

The other major factor which caused difficulty for the media was the many different sources of information during the first few days of the accident. These sources were typically giving similar information with varying degrees of pessimism. This situation understandably created a sense of confusion as to what was really happening.

Given all these shortcomings, the local media, especially the local radio stations, did an excellent job during the height of the crisis in sorting out the facts and getting accurate information to the public. Unfortunately, the national media generally tended to grossly sensationalize and distort what was actually happening and what the future might hold.<sup>26</sup> In the final analysis, the media must share some of the blame for creating the panic and crisis situation, a basis for which never existed to the degree that was reported.

It can be concluded that the TMI accident, although very serious, should not have caused by itself the crisis situation which existed for a very long period of time. The crisis was produced mainly by a combination of misinformation, poor communications and sensational media coverage.

Considering the number of successive operational, mechanical and design errors which caused the accident and the resulting fuel damage, the radiological consequences were relatively small. This can be considered fortunate because the lessons learned as a result of this accident have and will continue to improve the safety of nuclear power plants.

## FOOTNOTES

- 1 A thermoluminescent dosimeter or TLD is a small beta-gamma dosimeter consisting of a semiconductor chip which records the cumulative amount of radiation received wherever the dosimeter has been placed. When a measurement is desired the dosimeter is placed in a reader which records the radiation damage to the semiconductor chip and then thermally anneals the chip to relieve the damage allowing reuse of the dosimeter.
- 2 As can be seen from these first two figures the Pennsylvania Bureau of Radiation Protection had a modest environmental monitoring program in effect prior to the accident, the primary purpose of which was to perform an independent check of Met Ed's more extensive monitoring program. The state monitoring program is currently in the process of being expanded around all nuclear power plants in Pennsylvania. This is the direct result of recently appropriated state funds which have been requested over the past several years for this purpose.
- 3 Noble gases as the name implies are chemically inert and therefore do not bioaccumulate in any organ. They are only a hazard mainly due to external gamma radiation as the cloud passes by. Radioiodine concentrates in the thyroid gland and also in cows milk and is therefore primarily an ingestion or inhalation problem.
- 4 Taking these considerations into account, a more likely maximum individual dose would be about 30 millirem due to noble gases.
- 5 The highest level of radioiodine found in milk was about 40 picocuries/liter for a short period of time. This is about a factor of 10 less than that found over a much wider area during the Chinese fallout episode of 1976.
- 6 It should be noted that this TLD data would have been the primary method of estimating population exposure. It is therefore unfortunate but not extremely important from the standpoint of determining population exposure that the plant vent monitors went off scale early into the accident.
- 7 Population Dose and Health Impact of the Accident at the Three Mile Island Nuclear Station by Ad Hoc Population Assessment Group, May 10, 1979.
- 8 The person-rem concept is a means of measuring the collective dose received by a large population. It is simply determined by multiplying the dose to each segment of a population by the total number in that segment of the population. It is also a convenient method of determining risks to a population from exposure to radiation since most of the estimations are based on exposures to large population.
- 9 These risk factors are based on radiation exposures to entire average populations. They consequently take into consideration the risk to pregnant women and young children as well as others which are more susceptible to radiation exposure.



- 10 Fission products are a variety of radioactive elements which are created when the uranium atoms fission. In the process of decaying to a stable state they emit beta and/or gamma radiation. In this process they also generate heat, called decay heat, which must be removed even after the reactor has been shutdown to prevent the fuel from eventually melting. This decay heat level is about 6% of full thermal power immediately after reactor shutdown but decays very quickly following the exponential radioactive decay process of the fission products.
- 11 A loss of coolant accident is defined as any breach of the reactor coolant system, up to and including a double ended break of the largest pipe. This type of accident was considered to be the worst case design basis accident for a light water reactor. This philosophy will probably undergo substantial changes as a result of the lessons learned from the TMI accident.
- 12 These are open window measurements on portable survey meters which indicate the sum of the beta and gamma radiation. The much more penetrating gamma radiation was also routinely measured by closing the windows and was typically about 1/3 to 1/5 of this total beta/gamma measurement.
- 13 The maximum recorded reading offsite was 70 mrem/hr ( $\beta - \gamma$ ) near the North gate for a short period of time.
- 14 This undoubtedly led to an increased anxiety on the part of the NRC that the accident was much more severe than originally thought, and probably set the stage for the misconceived evacuation recommendation on Friday morning.
- 15 Later data was to indicate that this release on Friday morning which caused the ensuing anxiety and precipitous actions actually delivered only a few percent of the total dose received by any member of the public during the entire duration of the accident. Based on the monitoring information we had received throughout the course of the accident, we felt confident that the maximum cumulative offsite dose to any individual was less than 100 millirem. This was a factor of ten less than the EPA protective action guidelines upon which our plan was based and was consequently where we would have been prepared to recommend protective action to limit further public exposure.
- 16 Tom Gerusky, who was in the Governor's Office at this point, did not recommend against this advisory primarily because it was precautionary. It was thought that NRC should have been more knowledgeable about the real situation, and if our information was in error, it would have been very difficult to justify not taking this conservative course of action.
- 17 The makeup tank is essentially the surge tank for the reactor coolant letdown and makeup system, which was required at this time for the continued operation of the reactor coolant pump without unnecessarily drawing down the emergency supply of borated water. This tank is normally vented to the waste gas header which was suspected of having a leak, and which was causing a periodic release to the environment through the filtered auxiliary building ventilation system.

- 18 The source of makeup water could have been switched to the emergency borated water storage tank. However, this would have led to the eventual depletion of this tank and the consequent need to recirculate the reactor building sump water. Using this relatively unpurified source could have eventually led to more severe operational problems, and therefore the normal letdown/makeup system lineup was the preferred mode.
- 19 Actually, the waste decay tanks at this time were only at about 2/3 of their design pressure, but this had been a concern of the utility and they were in the process of rigging up a temporary line to vent these tanks into the reactor building.
- 20 Harold Denton was the senior NRC type in the IRC that morning and it was primarily his decision to recommend an evacuation.
- 21 Harold Denton was later to say that his concerns about evacuation went down by orders of magnitudes once he arrived on site later that afternoon and became better appraised of the situation.
- 22 Radiolysis in the decomposition of water into hydrogen and oxygen due to interaction of intense neutron and gamma irradiation.
- 23 In borated water solutions the rate of radiolytic decomposition is directly proportional to the energy absorption from neutron scattering and capture minus the gamma energy absorption. (Ref: Etherington, Nuclear Engineering Handbook, 1st Edition, 1958, p. 10-132). In addition, in gamma and neutron fields typical of power reactors, a hydrogen concentration of only 17 cc/kg is needed to suppress radiolysis in the primary coolant. (Ref: US Patent 2937981, 5/24/60). Noting that after the control rods were inserted the neutron flux was reduced by many orders of magnitude and that the actual hydrogen concentration in the reactor coolant on Friday was about 1670 cc/kg, it is obvious that radiolysis in the reactor coolant system was not physically possible.
- 24 The worst case scenario that was speculated was a core meltdown. According to the results of WASH-1400, the most exhaustive and authoritative study on the subject, the following would be the consequences of a reactor core meltdown. (No fault was found with this consequence model in the recent highly publicized independent review of this report.) The most likely core melt sequence (about 90% of all the possible scenarios leading to core melt) would be a core melt through, with the molten core eventually penetrating the base of the containment building and solidifying a few tens of feet beneath. The most likely consequences of this sequence would be very small; less than one early fatality, less than one additional latent cancer fatality per year and less than one additional genetic effect per year. (In the case of TMI, there would have been substantial groundwater and possible river water contamination that would have been difficult to clean up.) Prior to melt through there is the additional risk, based partly on the availability of some additional safeguard equipment, that the containment vessel could be breached. Assuming the worst possible atmospheric breach of containment combined with the worst case meteorology, population distribution and evacuation scenario, the maximum possible consequences would be much more serious. This could include about 3000 early fatalities, a 9% increase in fatal cancers, and a 2% increase in genetic effects to the assumed population.

In addition, there could be the requirement for temporary relocation from an area of about 300 square miles (much of which could be reclaimed in a short period of time with minimal decontamination) and crop and milk restrictions within an area of about 3000 square miles.

- 25 This was the condition in the reactor building outside of the reactor coolant system. Radiolysis was probably occurring in the water that was spilled on the floor of this building. This was one of the reasons for wanting to get a hydrogen recombiner in operation as soon as possible. The maximum hydrogen concentration in this building was measured at about 2.2%, well below the 4% necessary for burning or the 8% necessary for explosion.
- 26 It seemed the further away one went from TMI the worse the situation was reported as being. In fact, some foreign media reported that thousands had died as a result of the accident.

APPENDIX A

SUMMARY and DISCUSSION of FINDINGS from:

POPULATION DOSE and HEALTH IMPACT  
of the ACCIDENT at the  
THREE MILE ISLAND NUCLEAR STATION

(A preliminary assessment for the period  
March 28 through April 7, 1979)

Ad Hoc Population Dose Assessment Group

Lewis Battist	Nuclear Regulatory Commission
John Buchanan	Nuclear Regulatory Commission
Frank Congel	Nuclear Regulatory Commission
Christopher Nelson	Environmental Protection Agency
Mark Nelson	Department of Health, Education, and Welfare
Harold Peterson	Nuclear Regulatory Commission
Marvin Rosenstein	Department of Health, Education, and Welfare

May 10, 1979

This document contains only the "Preface" and "Summary and Discussion of Findings" sections of the full report. If the complete report is required, it may be obtained by calling (301) 443-3434, or writing to:

HFX-25, Bureau of Radiological Health  
5600 Fishers Lane  
Rockville, MD 20857

## PREFACE

This report was prepared by technical staff members of the Nuclear Regulatory Commission (NRC), the Department of Health, Education and Welfare (HEW), and the Environmental Protection Agency (EPA), who constitute an Ad Hoc Population Dose Assessment Group. It is an assessment of the health impact on the approximately 2 million offsite residents within 50 miles of the Three Mile Island Nuclear Station from the dose received by the entire population (collective dose). The Ad Hoc Group has examined in detail the available data for the period up to and including April 7, 1979. Based on a preliminary review of data from periods beyond April 7, it appears that the collective dose will not be significantly increased by extending the period past April 7.

The dose and health effects estimates are based primarily on thermoluminescent dosimeters placed at specific onsite and offsite locations. The dosimeters measure the cumulative radiation exposure that occurred at these locations. They permit the most direct evaluation of dose to the offsite population from radionuclides (radioactive materials) released to the environment.

The report also addresses several areas of concern about the types of radionuclides released, about the contribution to population exposure due to beta radiation (which does not penetrate the clothing and skin) emitted from the released radionuclides, about the degree of coverage afforded by available radiation measurements, and about the range of health effects that may result from the estimated collective dose.

Based on the current assessment, the Ad Hoc Group concludes that the offsite collective dose associated with radioactive material released during the period of March 28 to April 7, 1979 represents minimal risks (that is, a very small number) of additional health effects to the offsite population. The numerical statement of this conclusion is developed in the report. The Ad Hoc Group is not aware of any radiation measurements made during this period that would alter this basic conclusion, although refinement of the numerical estimates can be expected as the data are updated and verified. The members of the Ad Hoc Group concur that the manner in which the collective dose estimates were computed was conservative (overestimated the actual dose). The uncertainties in the collective dose estimates and health effects are not large enough to alter the Group's basic conclusion, that is, the risk is minimal.

# POPULATION DOSE AND HEALTH IMPACT OF THE ACCIDENT AT THE THREE MILE ISLAND NUCLEAR STATION

(A preliminary assessment for the period March 28 through April 7, 1979)

## Summary and Discussion of Findings

An interagency team from the Nuclear Regulatory Commission (NRC), the Department of Health, Education and Welfare (HEW) and the Environmental Protection Agency (EPA) has estimated the collective radiation dose received by the approximately 2 million people residing within 50 miles of the Three Mile Island Nuclear Station resulting from the accident of March 28, 1979. The estimates are for the period from March 28 through April 7, 1979, during which releases occurred that resulted in exposure to the offsite population. The principal dose estimate is based upon ground-level radiation measurements from thermoluminescent dosimeters located within 15 miles of the site. These estimates assume that the accumulated exposure recorded by the dosimeters was from gamma radiation (that is, penetrating radiation that contributes dose to the internal body organs). The data were obtained from dosimeters placed by Metropolitan Edison Company before the accident (as part of their normal environmental surveillance program), from dosimeters placed by Metropolitan Edison after the accident and covering the period to April 6, and from dosimeters placed by NRC from noon of March 31 through the afternoon of April 7, 1979. These measurement programs are continuing. The results for the period beyond April 7, 1979 have not been fully examined. An additional dose estimate developed by the Department of Energy using aerial monitoring that commenced about 4 p.m. on March 28, 1979 is also included. A variety of other data helpful in assessing relatively minor components of collective dose was also reviewed.

The collective dose to the total population within a 50-mile radius of the plant has been estimated to be 3300 person-rem. This is an average of four separate estimates that are 1600, 2800, 3300, and 5300 person-rem. The range of the collective dose values is due to different methods of extrapolating from the limited number of dosimeter measurements. An estimate provided by the Department of Energy (2000 person-rem) also falls within this range. The average dose to an individual in this population is 1.5 mrem (using the 3300 person-rem average value).

The projected number of excess fatal cancers due to the accident that could occur over the remaining lifetime of the population within 50 miles is approximately one. Had the accident not occurred, the number of fatal cancers that would be normally expected in a population of this size over its remaining lifetime is estimated to be 325,000. The projected total number of excess health effects, including all cases of cancer (fatal and non-fatal) and genetic ill health to all future generations, is approximately two.

These health-effects estimates were derived from central risk estimates within the ranges presented in the 1972 report of the Advisory Committee on the Biological Effects of Ionizing Radiation (BEIR) of the National Academy of Sciences. Preliminary information on the recently updated version of this report indicates that these estimates will not be significantly changed.

It should be noted that there exist a few members of the scientific community who believe the risk factors may be as much as two to ten times greater than the estimates of the 1972 BEIR report. There also is a minority of the scientific community who believe that the estimates in the 1972 BEIR report are two to ten times larger than they should be for low doses of gamma and beta radiation.

The maximum dose that an individual located offsite in a populated area might receive is less than 100 mrem. This estimate is based on the cumulative dose (83 mrem) recorded by an offsite dosimeter at 0.5 mile east-northeast of the site and assumes that the individual remained outdoors at that location for the entire period from March 28 through April 7. The estimated dose applies only to individuals in the immediate vicinity of the dosimeter site. The potential risk of fatal cancer to an individual receiving a dose of 100 mrem is about 1 in 50,000. This should be compared to the normal risk to that individual of fatal cancer from all causes of about 1 in 7.

An individual was identified who had been on an island (Hill Island) 1.1 miles north-northwest of the site during a part of the period of higher exposure. The best estimate of the dose to this individual for the 10-hour period he was on Hill Island (March 28 and March 29) is 37 mrem.

A number of questions concerning this analysis are posed and briefly answered below. More detailed discussions are included in the body of the report.

#### What radionuclides were in the environment?

The principal radionuclides released to the environment were the radioactive xenons and some iodine-131. Measurements made by the Department of Energy in the environment, measurement of the contents of the waste gas tanks, of the gases in the containment building and the actual gas released to the environment confirmed that the principal radionuclide released was xenon-133. Xenon-133 is a noble gas (which is chemically non-reactive) and does not persist in the environment after it disperses in the air. It has a short half-life of 5.3 days and produces both gamma and beta radiation. The risk to people from xenon-133 is primarily from external exposure to the gamma radiation, which penetrates the body and exposes the internal organs.

#### What were the highest radiation exposures measured outside the plant buildings?

Some of the Metropolitan Edison dosimeters located on or near the Three Mile Island Nuclear Station site during the first day of the accident recorded net cumulative doses as high as 1020 mrem. These recorded exposure readings do not apply directly to individuals located offsite. However, the onsite dosimeter readings were included in the procedure for projecting doses to the offsite population. This procedure is described in the report.

#### What is meant by collective dose (person-rem)?

The collective dose is a measure of the total radiation dose which was received by the entire population within a 50-mile radius of the Three Mile Island site. It is

obtained by multiplying the number of people in a given area by the dose estimated for that area and adding all these contributions.

Were the radiation measurements adequate to determine population health effects?

The extensive environmental monitoring and food sampling were adequate to characterize the nature of the radionuclides released and the concentrations of radionuclides in those media. The measurements performed by Department of Energy (aerial survey) and Metropolitan Edison and Nuclear Regulatory Commission (ground level dosimeters) are sufficient to characterize the magnitude of the collective dose and therefore the long-term health effects. However, a single precise value for the collective dose cannot be assigned because of the limited number of fixed ground level dosimeters deployed during the accident.

How conservative were the collective dose estimates?

In projecting the collective dose from the thermoluminescent dosimeter exposures, several simplifying assumptions were made that ignored factors that are known to reduce exposure. In each case, these assumptions introduced significant overestimates of actual doses to the population. This was done to ensure that the estimates erred on the high side. The three main factors that fall into this category are:

- (1) No reduction was made to account for shielding by buildings when people remained indoors.
- (2) No reduction was made to account for the population known to have relocated from areas close to the nuclear power plant site as recommended by the Governor of Pennsylvania, or who otherwise left the area.
- (3) No reduction was made to account for the fact that the actual dose absorbed by the internal body organs is less than the dose assumed using the net dosimeter exposure.

What is the contribution of beta radiation to the total dose?

Beta radiation contributes to radiation dose by inhalation and skin absorption. The total beta plus gamma radiation dose to the skin from xenon-133 is estimated to be about 4 times the dose to the internal body organs from gamma radiation. This additional skin dose could result in a small increase in the total potential health effects (about 0.2 health effect) due to skin cancer. The increase in total fatal cancers over that estimated for external exposure from gamma radiation alone would be about 0.01 fatal skin cancer. This contribution would be considerably decreased by clothing. The dose to the lungs from inhalation of xenon-133 for both beta and gamma radiation increases the dose to the lungs by 6 percent over that received by external exposure.



What radionuclides were found in milk and food and what are their significance?

Iodine-131 was detected in milk samples during the period March 31 through April 4. The maximum concentration measured in milk (41 pCi/liter in goat's milk, 36 pCi/liter in cow's milk) was 300 times lower than the level at which the Food and Drug Administration (FDA) would recommend that cows be removed from contaminated pasture. Cesium-137 was also detected in milk, but at concentrations expected from residual fallout from previous atmospheric weapons testing. No reactor-produced radioactivity has been found in any of the 377 food samples collected between March 29 and April 30 by the FDA.

Why have the estimates of radiation dose changed?

The original Ad Hoc Group estimate of collective dose (1800 person-rem presented on April 4 at the hearings before the Senate Subcommittee on Health and Scientific Research covered the period from March 28 through April 2. The data used for this estimate were obtained from preliminary results for Metropolitan Edison offsite dosimeters for the period March 28 through March 31 and preliminary results for NRC dosimeters for April 1 and 2. On April 10, the estimate of 2500 person-rem presented to the Senate Subcommittee on Nuclear Regulation by NRC Chairman Hendrie included the time period from March 28 through April 7. The data base for this estimate included additional NRC dosimetry results for April 3 through 7. The Ad Hoc Group's preliminary report of April 15 stated a value of 3500 person-rem for the time period from March 28 through April 7. This value resulted from better information on the dosimeter measurements and an improved procedure for analyzing the measurements.

The current report states an average value of 3300 person-rem (with a range of 1600 to 5300 person-rem) for the time period from March 28 through April 7. Additional dosimeter data were available and better methods were used to determine the collective dose. Also, the onsite dosimeter measurements are all included in the analysis.

The original estimate of maximum dose (80 mrem) to an individual presented on April 4 increased to 85 mrem in the April 15 preliminary report as a consequence of adding the contribution from April 2 to April 7. This estimate has now been revised slightly to 83 mrem, which is presented as less than 100 mrem so as not to imply more precision than this estimate warrants. New information on dosimeter readings on or very near the site was received after the initial analysis. It was also learned that an individual was present on one of the nearby islands (Hill Island) for a total of 10 hours during the period March 28 to March 29. The best estimate of the dose which may have been received by the individual is 37 mrem. The test includes a range of dose estimates for that individual.

Will these estimates of dose change again?

The dose and health effects estimates contained in this report are based on the dosimeter results for the period March 28 to April 7, 1979. There still remain some questions concerning interpretation of the dosimeter results. For example, the best values for subtracting background from the Nuclear Regulatory Commission dosimeters have not been determined. Recently available data from additional dosimeters

exposed during the March 28 to April 7 period have been reviewed briefly, but could not be included in the calculations in time for this report. The actual contribution to collective dose from the period after April 7, if any, has not been fully assessed. Therefore, the numerical dose values may be subject to some modification.

The Ad Hoc Group feels that these factors represent only minor corrections to the present estimates. In any case, none of the above refinements should cause an increase in any of the current estimates that would alter the basic conclusion regarding the health impact due to the Three Mile Island accident.

## Chronology of TMI-2 Accident 3/28/79

Events

- t = -1 sec. (0400:36) Plant operating normally (2155 psig) at 97%. Cond. polisher valve closed due to malfunction in air system. Booster pumps (2 of 3 operating) may have been first to trip. One condensate pump tripped (2 of 3 operating). Loss of both feedwater pumps on low suction pressure. Turbine trip.
- t = 0 + All three emergency feedwater pumps started (operating pressure at t = 14 sec.)
- t = 3 sec. E-M relief valve open at 2255
- t = 8 sec. Reactor trip on high pressure at 2345
- t = 13 sec. Operator isolated letdown, started another MU pump and opened HP injection isolation valve in anticipation of expected pressurizer level decrease.
- t = 13 sec. E-M relief valve solenoid de-energized giving closed position indication at 2205 psi (Valve did not reseal)
- t ≈ 10 sec. RCS temp. peaks at 611<sup>o</sup> F, 2345 psi pressurizer level peaks at 255 inches.
- t = 38 sec. Emergency feedwater valves open on S/G low level. Block valves closed so no feedwater admitted. S/G boil dry at t = 1:45. Pressure indication and valve position is only indication operator had of system status.
- t = 1-4 min. Pressurizer level started increasing. Based on rate of increase being greater than rate that can be accounted for, it is suspected that one or more steam voids formed in RCS at this time. This was the first indication, along with the still increasing pressure in the RC drain tank, which the operator had that would indicate a departure from what would normally be expected. Normally level and pressure would trend together following a loss of feedwater transient. Departure from normal was due to EM relief valve being open causing a reduction in pressure, while the loss of heat sink (S/G's boiling dry) was causing an expansion of the RCS. It is suspected that level instruments were not greatly in error based on an evaluation of all conceivable types of malfunctions.

t = 2:04 min. ECCS (HPI) initiation at 1600 psi.

t = 2:12 min. RC drain tank relief valve lifted. RC drain tank high temp. alarm at t = 3:26 min. Further indication of open E-M relief valve.

t = 3:14 min. Operator bypassed HPI portion of ECCS and throttled one of two injection isolation valves on "A" MU pumps in attempt to control pressurizing level. This reduced MU flow rate to about 3/4 of full flow at this operating point.

t = 4:38 min. Operator tripped MU pump "C" in further attempt to control pressurizing level. This reduced MU flow rate to about 1/2 of full SI flow at this operating point. "A" MU pump was still operating in throttled condition.

t ≈ 5 min. Operator initiates letdown flow in excess of 140 gpm in additional attempt to control pressurizing level. About 2 minutes later letdown flow is throttled back to about 70 gpm. At this point and continuing for about the next two hours (until E-M relief valve is shut) the amount of primary coolant being lost due to letdown and release through the open E-M relief valve is well in excess of that being added by one throttled MU pump. Therefore, during this approximate two hour period the voids in the RCS were steadily increasing and eventually led to the uncovering of the core.

t = 7:43 min. R.B. sump pump "A" automatically started on sump high level, presumably pumping about 140 gpm to the miscellaneous waste holding tank through normally open containment isolation valves. (These valves isolate on R.B. high pressure at 4 psig which had not yet been reached). This pump was instead lined up to the auxiliary building sump tank which had a blown rupture disk. This tank later overflowed into the auxiliary building sump and backed up and flooded most of the floor drains in the auxiliary building basement.

t = 8:00 min. Operator discovered very low level indication in both steam generators which would indicate they were dry. He then verified emergency feedwater system status and found both block valves closed. (The position indication for one of these valves may have been obscured by a caution tag from another valve controller). Operator opened the valves and fed both S/G with relatively cold feedwater causing additional shrinkage of the RCS without sufficient makeup.

t = 10:00 min. Pressurizer level came back on scale but remained high.

t = 10:19 R.B. sump pump "B" automatically started increasing total pumping rate to about 280 gpm.

t = 10:24 min. "A" MU pump tripped. Both pumps off for about 16 sec. "A" restarted at 10:40 min.

t = 14:50 min. RC drain tank rupture disk burst at about 190 psig.

t = 20 - 74 min. RCS stabilized near saturated conditions at about 1015 psig and 550° F. Operator periodically requested printout of E-M relief valve outlet temp. Reading was not conclusive that discharge was still occurring. RC flow gradually decreased during this period and various RCP related alarms occurred. Various building exhaust monitors showed small increase during this period. Chart recorder for source range instrumentation showed steadily increasing values during this period. This was indicative of slowly decreasing moderator density in the core but was not identified by operator.

t = 25 min. High radiation alarm on Intermediate closed cooling system. This monitor is physically located next to R.B. sump and was normally received following a reactor trip.

t = 38 min. R.B. sump pumps turned off by operator. Since discharge line was still not isolated (This did not occur until 4 psig was reached at about t = 4 hours) it is suspected that R.B. sump water continued to be transported at a low flowrate to the auxiliary building sump due to elevation differences and higher R.B. pressure.

t = 1:14 hour Operator tripped RCP's in "B" loop due to vibration alarms and fact that pumps had been below allowable limits for 4 pump operation. "B" loop closed to maintain pressurizer spray capability which comes from "A" loop.

t = 1:27 hour Operator isolated "B" steam generator. It was believed at this point that high R.B. pressure was due to steam leak from "B" steam generator since it was significantly lower in pressure than "A". Lower pressure was probably due to void which had formed in the "B" hot leg and was preventing flow through this steam generator.

t = 1:30 hour RCS sample indicated 400-500 ppm boron and 4 uc/ml. This was about a factor of ten increase in activity and a factor of two decrease in boron.

t = 1:40 hour

Operators decided to attempt natural circulation on "A" steam generator due to excessive vibrations on loop "A" RCP's. In preparation for this, level in "A" S/G was raised and both "A" loop RCP's were tripped. In subsequent interviews, the operators did not believe they had established natural circulation. However, the increase in source and intermediate range nuclear instrumentation was thought to be due to the boron dilution that measurements had been indicating. In fact, the operator had started an emergency boration cycle prior to this evolution. At about this time, the operator reported that they increased high pressure injection flow. The RCS pressure showed an increase and the source range monitors (SRM) showed a significant decrease which indicated the core voids had collapsed. The operators apparently did not note the significance of this.

A short while later the SRM showed an increase of about one decay which again indicated the core was becoming uncovered. The operator again reported that the "emergency boration." This condition remained for about 1 hour and 15 minutes, until after the E-M relief block valve was closed and pressure was increased above saturation.

t = 1:54 hour

RCS hot and cold leg temperature begin to diverge widely. The hot leg temperature went offscale at 620°F in about 14 minutes. The cold leg temperature dropped to about 150°F (apparently due to HPI water).

t = 2:22 hour

E-M relief block valve isolated by operator. Higher temperature readings on this valve finally led operators to believe that it was leaking. This action terminated the small loss of reactor coolant accident and RCS pressure began increasing from its low point of about 1300 psig.

t ≈ 2:40 hour

Area radiation monitors alarmed at the sample station and letdown line radiation monitor increased by about a factor of 100.

t = 2:45 hour

Operator opened isolation valves on "B" steam generator in preparation for attempting to restart RCP's. Several attempts were made to start RCP's in "A" loop. Finally a few minutes later RCP-2B was started. It remained in operation for about 19 minutes when it was tripped due to vibrations and a low operating current.

t ≈ 2:50 hour

A site emergency was declared. First notice to offsite agencies was initiated.

t = 2:56 hour  
Radiation alarm received from condenser off gas monitor. Operator again isolated "B" steam generator due to suspected primary to secondary leakage. A small amount of leakage within allowable technical specifications was occurring in this steam generator prior to the transient. It was suspected that cold feedwater into a dry steam generator may have increased the severity of this leakage.

t = 3:00 hour  
RCS pressure increased to 2130 psig. SRM again began to increase slightly.

t = 3:12 hour  
Operator opened E-M relief block valve in an attempt to establish normal pressurizer level. SRM count rate decreased to normal indication flow may have started through reactor core. As RCS pressure continued to decrease, SRM count rate again began to increase indicating steam again forming in the core.

t = 3:21 hour  
High pressure injection again initiated on decreasing pressure. Both MU pumps are started with full flow. SRM count rate rapidly decreased to normal indicating core void had again collapsed. SR and IR monitors would remain near normal levels from that point on. This is a good indication the core was not uncovered following this restoration of full HPI flow.

t ≈ 3:24 hour  
General emergency declared as a result of high radiation levels in the reactor building.

t ≈ 3:30 - 3:55 hour  
Operator attempts to control pressurizer level by cycling E-M relief block valve and by stopping "C" MU pump.

t = 3:56 hour  
Reactor building isolated by SFAS actuation at 4 psig.

t ≈ 4:00 - 5:15 hour  
With pressurizer level restored to about 380 inches and RCS pressure at 1500 psig additional attempts were made to start a RCP during this period. The containment dome monitor steadily increased from about 200 R/hr to about 6000 R/hr. Offsite monitoring teams were dispatched and reported < 1 mr/hr offsite.

t = 4:17 hour  
Both operating MU pumps ("A" & "C") tripped. Operator attempted to start one about one minute later. MU pump "B" started about 4½ minutes later.

About 10 minutes later MU pump "C" started by operator. Two MU pumps were running at full flow for about the next five hours.

t = 4:38 hour                      Steam dump to atmosphere began on "A" steam generator.

t = 5:15 -  
7:30                                  Operator closed E-M relief block valve in an attempt to raise pressure and collapse steam bubbles that they believed were in the loops. Pressure was controlled at about 2000-2200 psig. by cycling E-M relief block valve. Decay heat was being removed mainly by feed (HPI) and bleed (EMRV) process and somewhat dumping steam from "A" steam generator through atmosphere dump.

t = 6:14                                  RCS activity reported to be 140 uc/cc gross  $\beta^- \gamma$ .

t = 7:30 -  
10:30                                  Operator reduced RCS pressure by opening E-M relief block valve. This was done to insure that the core was covered since at about 600 psig. the core flood tanks would inject directly into reactor vessel on top of core. Once it was assured that the core was covered, an attempt would be made to further depressurize and initiate decay heat removal (the normal long term cooling mode using forced recirculation through an external cooling system) at 400 psig. About an hour later when the initiation pressure of the core flood tanks was reached, indications were that very little water was injected, therefore the operator felt confident that the core was covered. However, the RCS pressure could not be reduced below about 450 psig. which the operators attributed to reaching the saturation pressure of the loops. Decay heat was being removed mostly by feed (HPI and core flood) and bleed (EMRV and pressurizer vent) and somewhat by atmospherically dumping steam from "A" steam generator.

t = 8:30                                  Steam dump to atmosphere from "A" steam generator stopped at request of corporate management in response to concerns expressed by state government.

t = 9:50                                  ESF actuation on high R.B. pressure. (Building pressure experienced a short spike to 28 psig. which cleared within 11 seconds) R.B. spray was initiated and was shut off by operator after about 6 minutes. Since this occurred simultaneously with the operator opening the E-M relief block valve, it was believed that noise or an electrical cross connection had yielded a false signal. Some people in the control room reported hearing a dull thud at about this time. This indication is what was later believed to be a hydrogen explosion in containment. Since it caused no evidence of instrument or equipment failure, its significance is questionable except for indicating the extent of metal water reaction. If it was a hydrogen explosion, it was a localized occurrence based on its duration and effect.



t = 10:30 -  
13:30 hour

With RCS at about 500 psig. "A" loop Th decreased indicating that the bubble in the loop had collapsed. This was followed by an increase in Tc which was indication that some natural circulation was occurring. This is thought to be primarily the result of HP injection which was primarily directed to the "A" loop. It was still planned to try to further reduce pressure and go to low pressure injection followed by normal decay heat removal. Decay heat was now primarily being removed by the ongoing feed and bleed process.

t = 13:05

Started to draw a condenser vacuum. Started steaming "A" steam generator to condenser about 15 minutes later.

t = 13:30 -  
15:30

Since RCS pressure could not be reduced below about 450 psig. operators decided to repressurize RCS in an attempt to further collapse voids and start a RCP. With E-M relief block valve closed and MU flow at about 500 gpm with two pumps throttled, RCS was increased to about 2250 psig. in about one hour. In preparation for starting a RCP, MU flow was balanced with letdown and an attempt was made to draw a bubble in the pressurizer. Decay heat was now primarily being removed through some natural circulation in "A" steam generator which was steaming to the condenser.

t = 15:33

RCP-1A started for about 10 seconds as per the procedure for restart following loop filling. RCS pressure dropped to about 1450 psig.

t = 15:50

Operator started RCP-1A to establish forced circulation through the "A" loop. RCS pressure dropped from about 2250 to 1380 psig. and eventually stabilized at 1000 psig. Tave dropped to about 290° F and eventually stabilized at about 250° F.



U.S. NUCLEAR REGULATORY COMMISSION  
OFFICE OF STANDARDS DEVELOPMENT  
DRAFT REGULATORY GUIDE AND VALUE/IMPACT STATEMENT

May 1980  
Division 8  
Task OH 902-1

Contact: A. K. Roecklein (301) 443-5970

INSTRUCTION CONCERNING RISK FROM OCCUPATIONAL  
RADIATION EXPOSURE

A. INTRODUCTION

Section 19.12 of 10 CFR Part 19; "Notices, Instructions and Reports to Workers; Inspections," requires that all individuals working in or frequenting any portion of a restricted area be instructed in the health protection problems associated with exposure to radioactive materials or radiation. This guide describes the instruction that should be provided concerning biological risks to the worker from occupational radiation exposure.

B. DISCUSSION

It is generally accepted by the scientific community that exposure to ionizing radiation may cause biological effects that may be harmful to the exposed organism. These effects are generally classified into two general categories. These categories are Somatic Effects, i.e., effects occurring in the exposed person which, in turn, may be divided into two classes: prompt effects that are observable soon after a large or acute dose (e.g., 25 rems or more in a few hours) and delayed effects such as cancer that may occur years after exposure to radiation; and Genetic Effects,\* i.e., abnormalities that may occur in the children of exposed individuals and in subsequent generations. Concerns about these biological effects have resulted in stringent controls on

\*Genetic Effects have not been observed in any of the studies of exposed humans.

This regulatory guide and the associated value/impact statement are being issued in draft form to involve the public in the early stages of the development of a regulatory position in this area. They have not received complete staff review and do not represent an official NRC staff position.

Public comments are being solicited on both drafts, the guide (including any implementation schedule) and the value/impact statement. Comments on the value/impact statement should be accompanied by supporting data. Comments on both drafts should be sent to the Secretary of the Commission, U.S. Nuclear Regulatory Commission, Washington, D.C. 20555, Attention: Docketing and Service Branch, by July 21, 1980.

Requests for single copies of draft guides (which may be reproduced) or for placement on an automatic distribution list for single copies of future draft guides in specific divisions should be made in writing to the U.S. Nuclear Regulatory Commission, Washington, D.C. 20555, Attention: Director, Division of Technical Information and Document Control.

doses to individual workers and in efforts to control the collective dose (man-rem) to the worker population.

NRC licensee activities result in a significant fraction of the total occupational radiation exposure in the United States. Regulatory action has recently focused more attention on implementing the philosophy of maintaining occupational radiation exposure at levels that are as low as is reasonably achievable (ALARA). Radiation protection training for all workers who may be exposed to ionizing radiation is an essential component of any program designed to maintain exposure levels ALARA. A clear understanding of what is presently known about the biological risks associated with exposure to radiation will result in more effective radiation protection training and should generate more interest on the part of the worker in minimizing both individual and collective doses. In addition, radiation workers have the right to whatever information on radiation risk is available to enable them to make informed decisions regarding the acceptance of these risks.

At the relatively low levels of occupational radiation exposure in the United States, it is difficult to demonstrate correlations between exposure and effect. There is considerable uncertainty and controversy regarding estimates of radiation risk. In the appendix to this guide, a range of risk estimates is provided (see Table 1). Information on radiation risk has been included from such sources as the 1979 National Academy of Sciences Report of the Committee on the Biological Effects of Ionizing Radiation (BEIR 79),\* the International Commission on Radiological Protection (ICRP) Publication 27 entitled "Problems in Developing an Index of Harm," the 1979 report of the science work group of the Interagency Task Force on the Health Effects of Ionizing Radiation, the 1977 report of the United Nations Scientific Committee on the Effects of Atomic Radiation (UNSCEAR report), and numerous published articles (see the bibliography to the appendix).

### C. REGULATORY POSITION

Instruction to workers performed in compliance with §19.12 of 10 CFR Part 19 should be given prior to assignment to work in a restricted area and

\*The 1979 BEIR report, issued in draft form, is currently being revised. A final version is not yet released but the information from the draft used for this guide is not expected to change significantly.

periodically thereafter. In providing instruction concerning health protection problems associated with exposure to radiation, all workers, including those in supervisory roles, should be given specific instruction on the risk of biological effects resulting from exposure to radiation.

The instruction should include the information provided in the appendix to this guide and should be presented to all affected workers and supervisors. The information should be discussed during training sessions. Each individual should be given an opportunity to ask questions and should be asked to acknowledge in writing that the instruction has been received.

#### D. IMPLEMENTATION

The purpose of this section is to provide information to applicants regarding the NRC staff's plans for using this regulatory guide.

This proposed guide has been released to encourage public participation in its development. Except in those cases in which a licensee proposes an acceptable alternative method for complying with specified portions of the Commission's regulations, the methods to be described in the active guide reflecting public comments will be used in the evaluation of the instructional program for all individuals working in or frequenting any portion of a restricted area and for all supervisory personnel. Implementation by the staff will in no case be earlier than December 1, 1980.

APPENDIX TO DRAFT REGULATORY GUIDE OH 902-1

INSTRUCTION CONCERNING RISKS FROM  
OCCUPATIONAL RADIATION EXPOSURE

This instructional material is intended to provide the user with the best available information concerning what is currently known about the health risks from exposure to ionizing radiation. A question and answer format has been used. The questions were developed by the NRC staff in consultation with workers, union representatives, and licensee representatives experienced in radiation protection training. Risk estimates have been compiled from numerous sources generally recognized as reliable. A bibliography is included for the user interested in further study.

---

1. What is meant by risk?

Risk can be defined in general as the probability (chance) of injury, illness, or death resulting from some activity. The intent of this document is to estimate and explain the possible risk of injury, illness, or death resulting from occupational radiation exposure.

2. What are the possible health effects of exposure to radiation?

Some of the health effects that exposure to radiation may cause are cancer (including leukemia), birth defects in the children of exposed parents, and cataracts. These effects (with the exception of genetic effects) have been demonstrated in studies of medical radiologists, uranium miners, radium workers, and radiotherapy patients who received excessive doses in the early part of the century. Studies of people exposed to radiation from atomic weapons have also provided data on radiation effects. In addition, radiation effects studies with laboratory animals have provided a large body of data.

The studies mentioned, however, involve levels of radiation exposure that are much higher than those permitted occupationally today. Studies have not shown a clear cause-effect relationship between health effects and current levels of occupational radiation exposure.

3. What is meant by prompt effects, delayed effects, and genetic effects?

Prompt effects are observable shortly after receiving a very large dose in a short period of time. For example, a dose of 450 rems to an average adult will cause vomiting and diarrhea within a few hours; loss of hair, fever, and weight loss within a few weeks; and about a 50 percent chance of death within 1 month without medical treatment. Delayed effects such as cancer and cataracts may occur years after exposure to radiation. Genetic effects occur when there is radiation damage to the genetic material. These effects may show up as birth defects or other conditions in the offspring of the exposed individual and succeeding generations, as demonstrated in animal experiments, although this effect has not been observed in human populations.

4. As nuclear industry workers, which effects should concern us most?

Immediate or prompt effects are very unlikely since large exposures would normally occur only if there were a serious radiation accident. Accident rates in the nuclear industry have been low, and only a few accidents have resulted in overexposures. The probability of serious genetic effects in the children of workers is estimated at about one-third that of other delayed effects. The main concern to industry workers should be the delayed incidence of cancer. The chance of delayed cancer is believed to depend on how much radiation exposure a person gets; therefore, every reasonable effort should be made to keep exposures low.

5. What is the difference between acute and chronic exposure?

Acute radiation exposure, which causes prompt effects and may cause delayed effects, refers to a large dose of radiation received in a short period of time; for example, 450 rems received within a few hours or less. The effects of acute exposures are well known from studies of radiotherapy patients, atomic bomb

victims, and accidents that have occurred in nuclear fuel processing. There have been few occupational incidents that have resulted in large acute exposures. Chronic exposure, which may cause delayed effects but not prompt effects, refers to small doses received repeatedly over long time periods, for example, 20-100 mrem (a mrem is one-thousandth of a rem) per week every week for several years. Concern with occupational radiation risk is primarily focused on chronic exposure to low levels of radiation over long time periods.

6. How does radiation cause cancer?

How radiation causes cancer is not well understood. It is impossible to tell whether a given cancer was caused by radiation or by some other of the many apparent causes. However, most diseases are caused by the interaction of several factors. General physical condition, inherited traits, age, sex, and exposure to other cancer-causing agents such as cigarette smoke are a few possible interacting factors. One theory is that radiation activates an existing virus in the body which then attacks normal cells causing them to grow rapidly. Another is that radiation reduces the body's normal resistance to existing viruses which can then multiply and damage cells. Radiation can also damage chromosomes in a cell, and the cell is then directed along abnormal growth patterns. What is known is that, in groups of highly exposed people, a higher than normal incidence of cancer is observed. An increased incidence of cancer has not yet been observed at low radiation levels, although human studies are still incomplete. Higher incidence rates of cancer can be produced in laboratory animals by high levels of radiation.

7. If I receive a radiation dose, does that mean I am certain to get cancer?

Not at all. Everyone gets a radiation dose every day but most people do not get cancer. Even with doses of radiation far above legal limits, most individuals will experience no delayed consequences. There is evidence that the human body will repair some of the damage. The danger from radiation is much like the danger from cigarette smoke. Only a fraction of the people who breathe cigarette smoke get lung cancer, but there is good evidence that smoking increases a person's chances of getting lung cancer. Similarly, there is evidence that large radiation doses increase a person's chances of getting cancer.

Radiation is like most substances that cause cancer in that the effects can be seen clearly only at high doses. Still, it is prudent to assume that smaller doses also have some chance of causing cancer. This is as true for natural cancer-causers such as sunlight and natural radiation as it is for those that are man made such as cigarette smoke, smog, and man-made radiation. As even very small doses may entail some small risk, it follows that no dose should be taken without a reason. Thus, a time-honored principle of radiation protection is to do more than merely meet the allowed regulatory limits; doses should be kept as low as is reasonably achievable (ALARA).

We don't know exactly what the chances are of getting cancer from a radiation dose, but we do have good estimates. The estimates of radiation risks are at least as reliable as estimates for the effects from any other important hazard. Being exposed to typical occupational radiation doses is taking a chance, but that chance is small and reasonably well understood.

It is important to understand the probability factors here. A similar question would be: if you select one card from a full deck, will you get the ace of spades? This question cannot be answered with a simple yes or no. The best answer is that your chances are 1 in 52. However, if 1000 people each select one card from full decks, we can predict that about 20 of them will get an ace of spades. Each person will have 1 chance in 52 of drawing the ace of spades, but there is no way that we can predict which individuals will get the right card. The issue is further complicated by the fact that in 1 drawing by 1000 people, we might get only 15 successes and in another perhaps 25 correct cards in 1000 draws. We can say that if you receive a radiation dose, you will have increased your statistical chances of eventually developing cancer or some other radiation-related injury. The more radiation exposure you get, the more you increase your chances of cancer.

Clearly, there is no simple answer to this question. The best we can do is provide estimates, for large groups, of the increased chances of cancer or other radiation injury resulting from exposure to radiation.

A reasonable comparison involves exposure to the sun's rays. Frequent short exposures provide time for the skin to repair. An acute exposure to the sun can result in painful burning, and excessive exposure has been shown to cause skin cancer. Whether exposure to the sun's rays is short term or spread over time, some of the injury is not repaired and may eventually result in skin cancer.



The effect upon a group of exposed workers may be an increased incidence of cancer over and above the number of cancers that would be expected in that population. Each exposed individual has an increased probability of incurring subsequent cancer. We can say that if 10,000 workers each receive an additional 1 rem in a year, that group is more likely to have a larger incidence of cancer than 10,000 people who do not receive the additional radiation. An estimate of the increased probability of cancer from low radiation doses delivered to large groups is one measure of occupational risk.

8. What are the estimates of the risk of cancer from radiation exposure?

The cancer risk estimates (developed by the organizations identified in Question 9) are presented in Table 1.

TABLE 1

CANCER RISK ESTIMATES FROM EXPOSURE TO LOW-LEVEL RADIATION

Source	Number of Additional Cancers Estimated to Occur in 1 Million People After Exposure of Each to 1 Rem of Radiation
BEIR 1979	268-399
ICRP 1977	300*
UNSCEAR 1977	300*

\*ICRP and UNSCEAR both estimated 100 excess delayed deaths from these 300 radiation-induced cancers. Only about one-third of cancer cases are fatal. Note that the three independent groups are in close agreement on the risk of radiation-induced cancer.

To put these estimates (of Table 1) into perspective, we will use an average of 300 excess cancer cases per million people, each exposed to 1 rem of ionizing radiation. (Most scientists would agree that 300 is a high estimate of risk and may be considered an upper limit.) This means that if in a group of 10,000 workers each receives 1 rem, three would be predicted to develop cancer because of that exposure, although the actual number could be more or less than three (including none).

The American Cancer Society has reported that approximately 25 percent of all adults in the 20-65 year age bracket will develop cancer at some time from

all possible causes such as smoking, food, alcohol, drugs, air pollutants, and natural background radiation. Thus in any group of 10,000 workers not exposed to radiation on the job, we can expect about 2,500 to develop cancer. If this entire group of 10,000 workers were to receive an occupational radiation dose of 1 rem each, we could estimate that three additional cases might occur which would give a total of about 2,503. This means that a 1-rem dose to each of 10,000 workers might increase the cancer rate from 25 percent to 25.03 percent, an increase of about 3 hundredths of one percent.

As an individual, if your cumulative occupational radiation dose is 1 rem, your chances of eventually developing cancer during your entire lifetime may have increased from 25 percent to 25.03 percent. If your lifetime occupational dose is 10 rems, we could estimate a 25.3 percent chance of developing cancer.

The normal chance of developing cancer if you receive no occupational radiation dose is about equal to your chance of getting any spade on a single draw from a full deck of playing cards, which is one chance out of four. The additional chance of cancer from an occupational exposure of 1 rem is about equal to your chances of drawing three aces in a row from a deck of cards.

Since cancer resulting from exposure to radiation usually occurs 5 to 25 years after the exposure and since not all cancers are fatal, another useful measure of risk is years of life expectancy lost from a radiation-induced cancer. Several independent studies have indicated that the average loss of life expectancy from exposure to radiation is about 1 day per rem of exposure. In other words, an individual in a population exposed to 1 rem of radiation may on the average lose 1 day of life. The words "on the average" are important, however, because the individual who gets cancer from radiation may lose several years of life expectancy while his more fortunate coworkers suffer no loss. The International Commission on Radiological Protection (ICRP) estimated that the average number of years of life lost from a fatal industrial accident is 30 while the average number of years of life lost from a fatal radiation-induced cancer is 10.

It is important to realize that these risk numbers are only estimates. Many difficulties are involved in designing research studies that can accurately measure the small increases in cancer incidence due to low exposures to radiation as compared to the normal incidence of cancer. There is still uncertainty and a great deal of controversy with regard to estimates of radiation risk. The numbers used here result from studies involving high doses and high dose rates,

and they may not apply to doses at the lower occupational levels of exposure. At low dose levels, it is possible that the risk could be zero. The NRC and other agencies both in the United States and abroad are continuing extensive long-range research programs on radiation risk.

The National Academy of Sciences Advisory Committee on the Biological Effects of Ionizing Radiation (BEIR) and others feel that these risk estimates are higher than would actually occur and represent an upper limit on the risk. However, they are considered by the NRC staff to be the best available estimates that the worker can use to make an informed decision concerning acceptance of the risks associated with exposure to radiation. Although the estimated increased risks of cancer are relatively low, there is a chance that they are not zero. A worker who decides to accept this small increased risk should make every effort to keep exposure to radiation as low as is reasonably achievable to avoid unnecessary risk.

9. What groups of expert scientists have studied the risk from exposure to radiation?

Since 1956, the National Academy of Sciences established two advisory committees to consider radiation risks. The first of these was the Advisory Committee on the Biological Effects of Atomic Radiations (BEAR) and more recently it was renamed the Advisory Committee on the Biological Effects of Ionizing Radiation (BEIR). These committees have periodically reviewed the extensive research being done on the health effects of ionizing radiation and have published estimates of the risk of cancer from exposure to radiation (1972 and 1979\* BEIR reports). The International Commission on Radiological Protection (ICRP) and the National Council on Radiation Protection and Measurement (NCRP) are two groups of renowned scientists who have studied radiation effects and published risk estimates (ICRP Publication 26, 1977). In addition, the United Nations established an independent study group that published an extensive report in 1977, including estimates of cancer risk from ionizing radiation (UNSCEAR 1977).

---

\* The draft publication of the 1979 BEIR report is currently under revision. However, the risk estimates are not expected to change significantly.

10. Can a worker become sterile or impotent from occupational radiation exposure?

Observation of radiation therapy patients who receive localized exposures, usually spread over a few weeks, has shown that a dose of 500-800 rems to the gonads can produce permanent sterility in males or females (an acute whole-body dose of this magnitude would probably result in death within 30 days). An acute dose of 20 rems to the testes can result in a measurable but temporary reduction in sperm count. Such high exposures on the job could result only from serious and unlikely radiation accidents. The whole-body dose required to make someone impotent is also greater than the lethal dose. Thus, exposure to permitted occupational levels of radiation has no observed effect on fertility and should have no physical effect on the ability to function sexually.

11. How can we compare radiation risk to other kinds of health risks?

Perhaps the most useful unit for comparison among health risks is the average number of days of life expectancy lost per unit of exposure to each particular health risk. Estimates are calculated by looking at a large number of individuals, recording the age when death occurs from apparent causes, and estimating the number of days of life lost as a result of these early deaths. The total number of days of life lost is then averaged over the total group observed.

Several studies have compared the projected loss of life expectancy resulting from exposure to radiation with other health risks. Some representative numbers are presented in Table 2.

TABLE 2

ESTIMATED LOSS OF LIFE EXPECTANCY FROM HEALTH RISKS

<u>Health Risk</u>	<u>Estimates of Days of Life Expectancy Lost, Average</u>
Smoking 20 cigarettes/day	2370 (6.5 years)
Overweight (by 20%)	985 (2.7 years)
All accidents combined	435 (1.2 years)
Auto accidents	200
Alcohol consumption (U.S. average)	130
Home accidents	95
Drowning	41
Safest jobs (such as teaching)	30
Natural background radiation, calculated	8
Medical X-rays (U.S. average), calculated	6
All catastrophes (earthquake, etc.)	3.5
1 rem occupational radiation dose, calculated (industry average is 0.34 rem/yr)	1
1 rem/yr for 30 years, calculated	30
5 rems/yr for 30 years, calculated	150

These estimates indicate that the health risks from occupational radiation exposure are not greater than the risks associated with many other events or activities we encounter in normal day-to-day activities.

A second useful comparison is to look at estimates of the average number of days of life expectancy lost from exposure to radiation and from common industrial accidents at radiation-related facilities and to compare this number with days lost from other occupational accidents. Table 3 shows average days of life expectancy lost as a result of fatal work-related accidents. Note that the data for occupations other than radiation related do not include death risks from other possibly related hazards such as exposure to toxic chemicals, dusts, or unusual temperatures. Note also that occupational exposure at the 5 rems per year limit for 50 years, though highly unlikely, may result in a risk comparable to mining and heavy construction, using high-risk estimates.

TABLE 3

ESTIMATED LOSS OF LIFE EXPECTANCY FROM INDUSTRIAL ACCIDENTS\*

<u>Industry Type</u>	<u>Estimates of Days of Life Expectancy Lost, Average</u>
All industry	74
Trade	30
Manufacturing	43
Service	47
Government	55
Transportation and utilities	164
Agriculture	277
Construction	302
Mining and quarrying	328
Radiation accidents, death from exposure	<1
Radiation dose of 0.5 rem/yr, 50 years, calculated	25
Radiation dose of 5 rems/yr, 50 years	250
Industrial accidents at nuclear facilities (nonradiation)	58

\*  
Adapted from Cohen and Lee, A Catalogue of Risk and Health  
 Implications of Nuclear Power Production, World Health  
 Organization.

Industrial accident rates in the nuclear industry and related occupational areas have been relatively low during the entire history of the industry (see Table 4). This is due perhaps to the early and continuing emphasis on tight safety controls. The relative safety of various occupational areas can be seen by comparing the probability of accidental death per 10,000 workers over a 40-year working lifetime. These figures do not include death from possible causes such as exposure to toxic chemicals or radiation.

TABLE 4

PROBABILITY OF ACCIDENTAL DEATH BY TYPE OF OCCUPATION\*

<u>Occupation</u>	<u>Number of Accidental Deaths for 10,000 Workers for 40 Years</u>
Mining	252
Construction	228
Agriculture	216
Transportation and public utilities	116
All industries	56
Government	44
Nuclear industry (1975 data)	40
Manufacturing	36
Services	28
Wholesale and trade	24

\* Adapted from Accident Facts, National Safety Council, 1979,  
and Operational Accidents and Radiation Exposure Experience,  
WASH-1192, Atomic Energy Commission, 1975.

12. What are the NRC radiation dose limits?

Federal regulations currently limit occupational radiation dose to 1-1/4 rems in any calendar quarter or specified 3-month period. However, when there is documented evidence that a worker's previous occupational dose is low enough, a licensee may permit a dose of up to 3 rems per quarter or 12 rems per year. The accumulated dose may not exceed  $5(N - 18)$  rems where N is the individual's age in years, i.e., the lifetime occupational dose may not exceed an average of 5 rems for each year above the age of 18.

13. What is meant by ALARA?

In addition to providing an upper limit on an individual's permissible radiation exposure, the NRC also requires that its licensees maintain exposures as far below the limit as is reasonably achievable (ALARA). This means that every activity at a nuclear facility involving exposure to radiation should be planned so as to minimize unnecessary exposure to individual workers and also

to the worker population. A job that involves exposure to radiation should be done only when it is clear that the benefit justifies the risks assumed. All design, construction, and operating procedures should be reviewed with the objective of reducing unnecessary exposures.

14. Has the ALARA concept been applied if, instead of reaching dose limits during the first week of a quarter, the worker's dose is spread out over the whole quarter?

No. At low doses the health effects do not seem to be affected by dose rate. The risk of cancer from low doses is considered to be proportional to the amount of exposure, not the rate at which it is received. Spreading the dose out over time or over larger numbers of people does not reduce the overall risk. The ALARA concept has been followed only when the collective dose is reduced by reducing the time of exposure or decreasing radiation levels in the working environment.

15. What is meant by collective dose and why should it be maintained ALARA?

Nuclear industry activities expose an increasing number of people to occupational radiation in addition to the radiation doses they receive from natural background radiation and medical radiation exposures. The collective occupational dose (man-rem) is the sum of all occupational radiation exposure received by all the workers in an entire worker population. For example, if 100 workers each receive 2 rems, the individual dose is 2 rems and the collective dose is 200 man-rem. The total additional risk of cancer and genetic effects in an exposed population is assumed to depend on the collective dose.

It should be noted that, from the viewpoint of risk to a total population, it is the collective dose that must be controlled. For a given collective dose, the number of health effects is believed to be the same even if a larger number of people share the dose. Therefore, spreading the dose out may reduce the individual risk, but not that of the population.

Efforts should be made to maintain the collective dose ALARA so as not to unnecessarily increase the overall population incidence of cancer and genetic effects.



16. Is the use of extra workers a good way to reduce risks?

There is a "yes" answer to this question and a "no" answer. For a given job involving exposure to radiation, the more people who share the work, the lower the average dose to an individual. The lower the dose, the lower the risk. So, for you as an individual, the answer is "yes."

But how about the risk to the entire group of workers? The risk of cancer depends on the total amount of radiation energy absorbed by human tissue, not on the number of people to whom this tissue belongs. Therefore, if 30 workers are used to do a job instead of 10, and if both groups get the same collective dose (man-rems), the total cancer risk is the same, and nothing was gained for the group by using 30 workers. From this viewpoint the answer is "no." The risk was not reduced but simply spread around among a larger number of individuals.

Unfortunately, spreading the risk around often results in a larger collective dose for the job. Workers are exposed as they approach a job, while they are getting oriented to do the job, and as they withdraw from the job. The dose received during these actions is called nonproductive. If several crew changes are required, the nonproductive dose can become very large. Thus it can be seen that the use of extra workers may actually increase the total occupational dose and the resulting risks.

The use of extra workers to comply with NRC dose limits is not the way to reduce the risk of radiation-induced cancer for the worker population. At best, the total risk remains the same, and it may even be increased. The only way to reduce the risk is to reduce the collective dose; that can be done only by reducing the radiation levels, the working times, or both.

17. Why doesn't the NRC impose collective dose limits?

Compliance with individual dose limits can be achieved simply by using extra workers. However, compliance with a collective dose limit (such as 100 man-rems per year for a licensee) would require reduction of radiation levels, working times, or both. But there are many problems associated with setting appropriate collective dose limits.

For example, we might consider applying a single collective dose limit to all licensees. The selection of such a collective dose limit would be almost impossible because of the large variations in collective doses among licensees. A power reactor could reasonably be expected to have an average annual collective dose of several hundred man-rem. However, a small radiography licensee could very well have a collective dose of only a few man-rem in a year.

Even choosing a collective dose limit for a group of similar licensees would be almost as difficult. Radiography licensees as a group had an average collective dose in 1977 of 9 man-rem. However, the smallest collective dose for a radiography licensee was less than 1 man-rem, and the largest was 401 man-rem.

Setting a reasonable collective dose limit for each individual licensee would also be very difficult. It would require a record of all past collective doses on which to base such limits. Setting an annual collective dose limit would then amount to an attempt to predict a reasonable collective dose for each future year. In order to do this, it would be necessary to be able to predict changes in each licensed activity that would increase or decrease the collective dose. In addition, annual collective doses vary significantly from year to year according to the kind and amount of maintenance required, which cannot generally be predicted in advance. Following all such changes and revising limits up and down would be very difficult if not impossible. However, these efforts would be necessary if a collective dose limit were to be reasonable and help minimize doses and risks.

18. How are radiation dose limits established?

The NRC establishes occupational radiation dose limits based on guidance to Federal agencies from the Environmental Protection Agency (EPA) and on NCRP and ICRP recommendations. Scientific reviews of research data on biological effects such as the BEIR report are also considered.

19. What are the typical radiation doses received by workers?

The NRC requires that certain categories of licensees report data on annual worker doses and doses for all workers who terminate employment with licensees.

Data were received on the occupational doses in 1977 of approximately 100,000 workers in power reactors, industrial radiography, fuel processing and fabrication facilities, and manufacturing and distribution facilities. Of this total group, 85 percent received an annual dose of less than 1 rem according to these reports; 95 percent received less than 2 rems; fewer than 1 percent exceeded 5 rems in any 1 year. The average annual dose of these workers who were monitored and had measurable exposures is about 0.65 rem. A study completed by the EPA, using 1975 exposure data for 1,260,000 workers, indicated that the average annual dose for all workers who received a measurable dose was 0.34 rem.

20. What happens if a worker exceeds the quarterly exposure limit?

Radiation protection limits, such as 3 rems in 3 months, are not absolute limits below which it is safe and above which there is danger. Exceeding a limit does not imply that you have suffered an injury. A good comparison is with the highway speed limit which is selected to limit accident risk and still allow you to get somewhere. If you drive at 75 mph, you increase your risk of an auto accident to levels that are not considered acceptable by the people who set speed limits, even though you may not actually have an accident. If a worker's radiation dose repeatedly exceeds 3 rems in a quarter, the risk of health effects could eventually increase to a level that is not considered acceptable to the NRC. Exceeding an NRC protection limit does not necessarily mean that any adverse health effects are going to occur. It does mean that a licensee's safety program has failed in some respect and that the NRC and the licensee should investigate to make sure the problems are corrected.

If an overexposure occurs, the regulations prohibit any additional occupational exposure to that individual during the calendar quarter. The licensee is required to file a report to the NRC and may possibly be subject to a fine, just as you are subject to a traffic fine for exceeding the speed limit. In both cases, the fines and, in some serious or repetitive cases, suspension of license are intended to encourage efforts to operate within the limits. The safest limits would be 0 mph and 0 rem per quarter. But then we wouldn't get anywhere.

21. Why do some facilities establish administrative limits that are below the NRC limits?

There are two reasons. First, paragraph 20.1(c) of the NRC regulations states that licensees should keep exposures to radiation ALARA. By requiring specific approval for worker doses in excess of set levels, more careful risk-benefit analysis can be made as each additional increment of dose is approved for a worker. Secondly, a facility administrative limit that is set lower than the quarterly NRC limit provides a safety margin designed to help the licensee avoid overexposures.

22. Several scientists have recently suggested that NRC limits are too high and should be lowered. What are the arguments for lowering the limits?

In general, those critical of present dose limits say that the individual risk is higher than estimated by the BEIR Committee and the ICRP. A few studies have indicated that a given dose of radiation may be more likely to cause biological effects than previously thought. The controversy is focused on studies involving groups of exposed individuals. Opinions differ on the validity of the research methods used and the methods of statistical analysis. The chief problem is that, with small groups, the incidence of effects such as leukemia is small. It cannot be shown without question that these effects were more frequent in the exposed study group than in the unexposed group used for comparison or that any observed effects were caused by the exposure to radiation.

The current BEIR committee concluded that claims of higher risk had "no substance," and nearly one-half of the committee members were convinced that the BEIR risk estimates were actually too high. The NRC staff is committed to a continuing review of research on radiation risk and is funding a study to design new research on human effects from exposure to radiation.

23. What are the arguments against lowering the NRC dose limits?

The estimated health risks associated with current average occupational radiation doses (e.g., 0.5 rem/yr for 50 years) are comparable to or less than risk levels in other occupational areas considered to be among the safest.

Exposure to 5 rems/yr for 50 years, which virtually never occurs, would increase the estimated risk to levels comparable to risks in mining and heavy construction. If the dose limits were lowered significantly, the number of people required to complete many jobs would increase. The collective dose would then increase since more individuals would be receiving nonproductive exposure while entering and leaving the work area and preparing for the job. The total number of health effects might go up as the collective dose increased.

The regulatory standards for dose limits are based on the recommendations of the Federal Radiation Council, the NCRP, and the ICRP. At the time these standards were developed, about 1960, it was considered unlikely that exposure of these levels during a working lifetime would result in clinical evidence of injury or disease different from that occurring in the unexposed population. The scientific data base for the standards consisted primarily of human experience (X-ray exposures to medical practitioners and patients, ingestion of radium by watch dial painters, early effects observed in Japanese atomic bomb survivors, radon exposures of uranium miners, occupational radiation accidents) involving very large doses delivered at very high dose rates. The data base also included the results of a large number of animal experiments involving high doses and dose rates. The animal experiments were particularly useful in the evaluation of genetic effects. The observed effects were related to low-level radiation through a linear, nonthreshold extrapolation procedure. Based on this approach, the regulations in 10 CFR Part 20, "Standards for Protection Against Radiation," also state that licensees should maintain all radiation exposures, and releases of radioactive materials in effluents, as low as is reasonably achievable.

Reducing the dose limits, for example, by a factor of 10 (that is, from 5.0 rems/yr to 0.5 rem/yr) has been analyzed by the NRC staff. An estimated 2.6 million man-rems could be saved from 1980 through the year 2000 by nuclear power plant licensees if compliance with the new limit was achieved by lowering the radiation levels, working times, or both, rather than by using extra workers. It is estimated that something like \$23 billion would be spent toward this purpose. Spending \$23 billion to save 2.6 million man-rems would amount to spending \$30 to \$90 million to prevent each potential radiation-induced cancer death. Society may consider this cost unacceptably high for individual protection.

24. Are there any areas of concern about radiation risks that might result in lowering the NRC dose limits?

Three areas of concern to the NRC staff are specifically identified below:

a. An independent study has indicated that a given dose of neutron radiation is more likely to cause biological effects than previously thought. Although the scientific community has not yet agreed with the results of this study, workers should be advised of the possibility of higher risk when entering areas where exposure to neutrons will occur.

b. It has been known for some time that rapidly growing living tissue is more sensitive to injury from radiation than tissue in which the cells are not reproducing rapidly. Thus the unborn embryo or fetus is more sensitive to radiation injury than an adult. The NCRP recommended in Report No. 39 that special precautions be taken when an occupationally exposed woman could be pregnant in order to protect the embryo or fetus. In 1975, the NRC issued Regulatory Guide 8.13, "Instruction Concerning Prenatal Radiation Exposure," in which it is recommended that licensees instruct all workers concerning this special risk. The guide recommends that all workers be advised that the NCRP recommended the maximum permissible dose to the embryo or fetus from occupational exposure of the mother should not exceed 0.5 rem for the full 9-month pregnancy period. In addition, the guide suggests options available to the female employee who chooses not to expose her unborn child to this additional risk.

c. Also of special interest is the indication that female workers are subject to more risk than male workers. In terms of all types of cancer except leukemia, the 1979 BEIR analysis indicates that female workers have a risk of developing radiation-induced cancer that is approximately one and one-half times that for males. Incidence of radiation-induced leukemia is about the same for both sexes. Female workers should consider carefully this difference in the risks of radiation-induced cancer in deciding whether or not to seek work involving exposure to radiation.

25. How much radiation does the average person who does not work in the nuclear industry receive?

We are all exposed from the moment of conception to ionizing radiation from several sources. Our environment, and even the human body, contains naturally

occurring radioactive materials that contribute some of the background radiation we receive. Cosmic radiation originating in space and in the sun contributes additional exposure. The use of X-rays and radioisotopes in medicine and dentistry adds considerably to our population exposure.

Table 5 shows estimated average individual exposure in millirems from natural background and other sources.

TABLE 5

U.S. GENERAL POPULATION EXPOSURE ESTIMATES (1978)\*

<u>Source</u>	<u>Average Individual Dose (mrem/yr)</u>
Natural background	100
Release of radioactive material by mining, milling, etc.	5
Medical	90
Nuclear weapons development (primarily fallout)	5-8
Nuclear energy	0.28
Consumer products	0.03
<u>Total</u>	<u>~ 200 mrem/yr</u>

\* Adapted from a report by the Interagency Task Force on the Health Effects of Ionizing Radiation published by the Department of Health, Education, and Welfare.

Thus, the average individual in the general population receives about 0.2 rem of radiation exposure each year from sources that are a part of our natural and man-made environment. By the age of 20 years, an individual has accumulated about 4 rems. The most likely target for reduction of population exposure is medical uses.

26. Why aren't medical exposures considered as part of a workers allowed dose?

Equal doses of medical and occupational radiation have equal risks. Medical exposure to radiation should be justified for reasons quite different, however, from those applicable to occupational exposure. A physician prescribing an X-ray should be convinced that the benefit of the resulting medical information

justifies the risk associated with the radiation. Each worker must decide on the acceptance of occupational radiation risk just as each worker must decide on the acceptability of any other occupational hazard.

For another point of view, consider a worker who receives a series of X-rays or a radiopharmaceutical in connection with an injury or illness resulting in a dose of 2 rems. This dose and implied risk should be justified on medical grounds. If the worker had also received 2 rems of dose on the job, the combined dose of 4 rems would not incapacitate the worker. Restricting the worker from additional job exposure during the quarter would have no effect one way or the other on the risk from the 2 rems already received from medical exposure. If the individual worker accepts the risks associated with the X-rays on the basis of the medical benefits and the risks associated with job-related exposure on the basis of employment benefits, it would be inequitable to restrict the individual from employment in restricted areas for the remainder of the quarter.

27. What is meant by internal exposure?

Internal exposure to radiation results when radioactive materials are taken into the body by breathing, ingestion, or absorption through the skin. Different types of material locate for a period of time in different parts of the body or pass through the body, resulting in some dose to the exposed tissues.

Internal exposure can be estimated by measuring the radiation emitted from the body or by measuring the radioactive materials contained in biological samples such as urine or feces. Dose estimates can also be made if one knows how much radioactive material is in the air and the length of time during which the air was breathed.

28. How are the limits for internal exposure set?

Calculations are made to determine the quantity of radioactive material that has been taken into the body and the total organ dose that would result. Then, based on limits established for particular body organs similar to 1-1/4 rems in a calendar quarter for whole-body exposure, the regulations specify maximum permissible concentrations of radioactive material in the air to which a worker can be exposed for 40 hours per week. The regulations also require that efforts be made to keep internal exposure ALARA.



Internal exposure is controlled by limiting the release of radioactive material into the air and by carefully monitoring the work area for airborne radioactivity and surface contamination. Protective clothing and respiratory (breathing) protection may be used whenever the possibility of contact with loose radioactive material cannot be prevented.

29. Is the dose an individual received from internal exposure added to that received from external exposure?

Exposure to radiation that results from radioactive materials taken into the body is measured, recorded, and reported to the worker separately from external dose. The internal dose to the whole body or to specific organs does not at this time count against the 3 rems per calendar quarter limit. ICRP recommendations are that the internal and external doses should be summed. This recommendation is under study by the staffs of the NRC and the EPA.

30. How is a worker's radiation dose determined?

A worker may wear two types of radiation-measuring devices. A self-reading pocket dosimeter records the exposure to incident radiation and can be read out immediately upon finishing a job involving external exposure to radiation. A film badge or TLD badge records radiation dose, either by the amount of darkening of the film or by storing energy in the TLD crystal. Both these devices require processing to determine the dose and are considered more reliable than the pocket dosimeter. A worker's official report of dose received is normally based on film or TLD badge readings.

31. What are my options if I decide not to accept the risks associated with occupational radiation exposure?

If the risks from exposure to radiation that may be expected to occur during your work are unacceptable to you, you could request a transfer to a job that does not involve exposure to radiation. However, the risks associated with exposure to radiation that workers, on the average, actually receive are considered acceptable, compared to other occupational risks, by virtually all the

scientific groups that have studied them. Thus, your employer is not obligated to guarantee you a transfer if you decide not to accept an assignment requiring exposure to radiation.

You also have the option of seeking other employment in a nonradiation occupation. However, the studies that have compared occupational risks in the nuclear industry to those in other job areas indicate that nuclear work is relatively safe. Thus, you will not necessarily find significantly lower risks in another job.

A third option would be to practice the most effective work procedures so as to keep your exposure ALARA. Be aware that reducing time of exposure, maintaining distance from radiation sources, and using shielding can all lower your exposure. Plan radiation jobs carefully to increase efficiency while in the radiation area. Learn the most effective methods of using protective clothing to avoid contamination. Discuss your job with the radiation protection personnel who can suggest additional ways to reduce your exposure.

32. Where can I get additional information on radiation risk?

The following list suggests sources of useful information on radiation risk:

Your Employer

The radiation protection or health physics office in the facility where you are employed.

Nuclear Regulatory Commission

Address: Occupational Health Standards Branch  
Office of Standards Development  
U.S. Nuclear Regulatory Commission  
Washington, D.C. 20555

Phone: 301-443-5970

NRC Regional Offices

King of Prussia, PA 19406	215-337-5000
Atlanta, GA 30303	404-221-4503
Glen Ellyn, IL 60137	312-932-2500
Arlington, TX 76012	817-334-2841
Walnut Creek, CA 94596	415-943-3700

Department of Health, Education, and Welfare

Address: Office of Public Affairs  
Bureau of Radiological Health  
Department of Health, Education, and Welfare  
Room 15-B-42, HF1-40  
5600 Fishers Lane  
Rockville, MD 20857

Phone: 301-443-3285

Environmental Protection Agency

Address: Office of Radiation Programs  
U.S. Environmental Protection Agency  
401 M Street, SW  
Washington, D.C. 20460

Phone: 703-557-9710

## BIBLIOGRAPHY

The Effects on Populations of Exposure to Low Levels of Ionizing Radiation, Report of the Committee on the Biological Effects of Ionizing Radiation, National Academy Sciences, 1979.

Biologic Effects of Ionizing Radiation, Report of the Science Work Group of the Interagency Task Force on Radiation, DHEW, June 1979.

Radiation Protection, Recommendations of the International Commission on Radiological Protection, ICRP Publication 26, Pergamon Press, January 1977.

Problems Involved in Developing an Index of Harm, Annals of the ICRP, ICRP Publication 27, Pergamon Press, May 1977.

1978 Cancer Facts and Figures, American Cancer Society, 1977.

Sources and Effects of Ionizing Radiation, United Nations Scientific Committee on the Effects of Atomic Radiation, 1977, Report to the General Assembly, UN Publication No. E.77.IX.I, 1977.

Health Implications of Nuclear Power Production, Report on a Working Group, World Health Organization, December 1975.

Operational Accidents and Radiation Exposure Experience, WASH-1192, Atomic Energy Commission, Fall 1975.

H. Inhaber, Risk of Energy Production, AECB-1119/Rev. 1, Atomic Energy Control Board, May 1978.

M. H. Barnett, The Biological Effects of Ionizing Radiation: An Overview, DHEW Publication (FDA) 77-8004, October 1976.

R. Muller, "Natural Radiation Background vs. Radiation from Nuclear Power Plants," J. of Environmental Sciences, August 1972.

R. E. Lapp, A Workers Guide to Radiation, Atomic Industrial Forum, August 1979.

R. E. Lapp, The Radiation Controversy, Reddy Communications, Inc., Greenwich, Conn., 1979.

R. L. Gotchy, "Estimation of Life Shortening Resulting from Radiogenic Cancer per Rem of Absorbed Dose," Health Physics, Vol. 35, October 1978.

E. J. Hall, Radiation and Life, Pergamon Press, 1976.

B. L. Cohen and I. S. Lee, "A Catalog of Risks," Health Physics, Vol. 36, June 1979.

C. A. Kelsey, "Comparison of Relative Risk from Radiation Exposure and Other Common Hazards," Health Physics, Vol. 31, August 1978.

## DRAFT VALUE/IMPACT STATEMENT

### 1. PROPOSED ACTION

#### 1.1 Description

All NRC licensees are required to provide appropriate radiation protection training for all permanent and transient personnel who work in restricted areas (§19.12 of 10 CFR Part 19). A clear and reasonable assessment of the biological risks associated with occupational radiation exposure is essential to effective radiation protection training. The proposed action is to provide instructional material in a suitable form describing and estimating the risks from exposure to radiation. The instructional material will be suitable for use in licensee training programs and will represent an acceptable method of complying with part of the existing training requirements.

#### 1.2 Need for Proposed Action

One common element of those occupational areas encompassed by NRC licensing activity is worker exposure to ionizing radiation and the biological risks from exposure. Union representatives have expressed a dissatisfaction with the way in which these risks have been explained to the worker by the licensee. In addition, they feel the NRC has a responsibility to make its position on the controversial issue of radiation risk clear to the worker and the public. A meeting of NRC staff and union representatives was held on November 28, 1978, during which this matter was discussed. A transcript of the meeting is available from the Public Document Room.

The Commission has directed the staff to prepare for and initiate a public hearing concerning the adequacy of present occupational radiation protection standards for exposure of individuals. This hearing should help resolve existing uncertainties in this complex area and the findings should, as a minimum, be published in a form suitable for instruction of the worker. Work on this project began prior to the public hearings so that updated information on risk could be disseminated to the worker shortly after the hearing. Most of the questions

of concern to the unions can be disseminated to the worker shortly after the hearing. Most of the questions of concern to the unions can be answered now.

### 1.3 Value/Impact of Proposed Action

#### 1.3.1 NRC Operations

Instructional material on radiation risk written at a level and scope understandable to the worker should contribute to increased confidence, on the part of the worker, in the NRC in general. A better understanding of the risk should elicit more worker cooperation with NRC-enforced safety programs. Impacts of the development of instructional material on risk are task completion manpower cost, estimated to be 0.2 man-year and printing costs of approximately \$400.00.

#### 1.3.2 Other Government Agencies

Agreement States whose licensing regulations include radiation protection training requirements may benefit from the availability of an NRC guide on radiation risk suitable for inclusion in those training programs. Development of the risk guide entails coordination with the Environmental Protection Agency, the Occupational Safety and Health Administration, and the Bureau of Radiological Health to avoid inconsistencies.

#### 1.3.3 Industry

Providing a reasonable and understandable statement on worker risk should facilitate industry efforts to provide effective safety training and to better achieve as low as is reasonably achievable (ALARA) objectives. Minimal impact is expected in the form of additional cost of training programs since training requirements already exist. Input from unions and industry in the development of instructional material on risk will be encouraged, and this implies some additional costs such as staff time for reviewing drafts.

#### 1.3.4 Workers

The proposed action should improve worker protection in that reasonable understanding of radiation risk is essential to the development of safe working practices. The staff believes that an objective discussion of radiation risk may in fact reduce "over concern" on the part of some workers. If improved training results in a wider recognition and respect for radiation as an

industrial hazard, more attention will be given to protective procedures and a reduction in individual and collective dose should result.

#### 1.3.5 Public

Nuclear workers are also members of the public and are generally residents of the area where facilities are located. Having a better informed public should result in a wider range of input to local decisionmaking concerning nuclear development. Improved training implies the added benefit of increased plant safety, thereby decreasing the probability of accidents that could involve the public.

#### 1.3.6 Decision on Proposed Action

The NRC should develop and provide instructional material concerning risk from occupational radiation exposure.

### 2. TECHNICAL APPROACH

The technical approach proposed is to develop instructional material concerning risks to the worker from occupational radiation exposure and to publish the material in a form that will receive the widest dissemination among NRC-licensed facilities. An alternative is to publish the findings of the proposed hearing on dose limits and assume the relevant information will filter down to the worker. It is the feeling of the staff that a direct approach is required here.

### 3. PROCEDURAL APPROACH

The proposed action, to publish training material concerning risks from occupational radiation exposure, the use of which would be required of all licensees, could be accomplished by several alternative methods. These include an NRC regulation requiring that specific training materials be used, a regulatory guide based on the existing §19.12 that would provide an acceptable method for training on risks, an ANSI standard on training that could be adopted by a regulatory guide, and a NUREG report or a branch position paper.

### 3.1 Value/Impact of Procedural Alternatives

An NRC regulation establishes general legal requirements, is costly and time consuming to prepare, and is not an appropriate vehicle for the specific and narrow objective proposed here. A regulation would be difficult to modify as new information on radiation risk is developed. One advantage is that a regulation legally requires compliance. In general, this approach is not considered cost effective in view of the objectives of the proposed action.

ANSI standards are generally intended as highly technical and advanced treatments of specialized areas of concern to industry. A comprehensive technical review of risks from radiation would be of value but would not be suitable as instructional material at an introductory level for worker radiation protection training. Completion of an ANSI standard and an endorsing regulatory guide would require several years and would be too costly. This approach is not considered cost effective in view of the proposed objectives.

A NUREG document would be an appropriate vehicle for a comprehensive discussion of radiation risk beyond the scope of what is proposed here. A regulatory position, however, is not established through publication of a NUREG report. Since this proposal includes establishing an acceptable method for compliance with elements of required training programs, a NUREG report is not suitable.

Branch position statements are intended as interim measures to be used when an immediate response is required. They are usually superseded when a more permanent mode of guidance is developed.

A regulatory guide can be prepared at reasonable cost within a reasonable time period. The staff does not consider that revision of any existing regulatory guides could provide the instructional material intended here. Regulatory guides on training requirements are being developed but are specific to types of licensees such as Draft Regulatory Guide OH 717-4 for LWRs. The action proposed here has broad application to all licensees, as does Regulatory Guide 8.13, "Instruction Concerning Prenatal Radiation Exposure."

### 3.2 Decision on Procedural Approach

The staff concludes that work should begin on a regulatory guide similar to Regulatory Guide 8.13 on the subject of worker instruction concerning risks



from occupational radiation exposure. Publication of the active guide should not occur until public hearings on the question of dose limits and risks have been held.

#### 4. STATUTORY CONSIDERATIONS

##### 4.1 NRC Regulatory Authority

Section 19.12 of 10 CFR Part 19 establishes a legal requirement that all NRC licensees provide radiation protection training to personnel and that the training be commensurate with the potential risks from radiation exposure encountered by those personnel. The NRC is thus authorized to provide criteria for acceptable levels of training and to inspect for compliance with training requirements.

##### 4.2 Need for NEPA Statement

The action proposed here is to publish an instructional document on risks. This would occur after, and be in addition to, any major NRC action on retaining or modifying existing dose limits, based on planned public hearings. Since at that time it would not constitute a major addition or change and would entail no effect on the environment, an environmental impact statement is not considered necessary.

#### 5. RELATIONSHIP TO OTHER EXISTING OR PROPOSED REGULATIONS OR POLICIES

Regulatory Guide 1.70, "Standard Format and Content of Safety Analysis Reports for Nuclear Power Plants," will require a commitment to appropriate radiation protection training. When next revised, it should include reference to this proposed action as an acceptable element of a licensee's training program.

This proposed guide is consistent with Regulatory Guide 8.8, "Information Relevant to Ensuring that Occupational Exposures at Nuclear Power Stations Will Be As Low As Is Reasonably Achievable." When next revised, it should include cross-reference to this proposed action.

This proposed action directly supplements the Draft Regulatory Guide OH 717-4, "Radiation Protection Training for Light-Water-Cooled Nuclear Power Plant Personnel,"

and will supplement and be referenced in other planned guides on training at other types of licensed facilities, e.g., uranium fuel fabrication plants, uranium mills, medical institutions.

6. SUMMARY AND CONCLUSIONS

In summary, it is proposed that a regulatory guide be prepared and issued for the purpose of providing instructional material concerning an assessment of risk from occupational radiation exposure.

UNITED STATES  
NUCLEAR REGULATORY COMMISSION  
WASHINGTON, D. C. 20555

OFFICIAL BUSINESS  
PENALTY FOR PRIVATE USE, \$300

POSTAGE AND FEES PAID  
U.S. NUCLEAR REGULATORY  
COMMISSION



## BIBLIOGRAPHY

The Effects on Populations of Exposure to Low Levels of Ionizing Radiation, Report of the Committee on the Biological Effects of Ionizing Radiation, National Academy Sciences, 1979.

Biologic Effects of Ionizing Radiation, Report of the Science Work Group of the Interagency Task Force on Radiation, DHEW, June 1979.

Radiation Protection, Recommendations of the International Commission on Radiological Protection, ICRP Publication 26, Pergamon Press, January 1977.

Problems Involved in Developing an Index of Harm, Annals of the ICRP, ICRP Publication 27, Pergamon Press, May 1977.

1978 Cancer Facts and Figures, American Cancer Society, 1977.

Sources and Effects of Ionizing Radiation, United Nations Scientific Committee on the Effects of Atomic Radiation, 1977, Report to the General Assembly, UN Publication No. E.77.IX.I, 1977.

Health Implications of Nuclear Power Production, Report on a Working Group, World Health Organization, December 1975.

Operational Accidents and Radiation Exposure Experience, WASH-1192, Atomic Energy Commission, Fall 1975.

H. Inhaber, Risk of Energy Production, AECB-1119/Rev. 1, Atomic Energy Control Board, May 1978.

M. H. Barnett, The Biological Effects of Ionizing Radiation: An Overview, DHEW Publication (FDA) 77-8004, October 1976.

R. Muller, "Natural Radiation Background vs. Radiation from Nuclear Power Plants," J. of Environmental Sciences, August 1972.

R. E. Lapp, A Workers Guide to Radiation, Atomic Industrial Forum, August 1979.

R. E. Lapp, The Radiation Controversy, Reddy Communications, Inc., Greenwich, Conn., 1979.

R. L. Gotchy, "Estimation of Life Shortening Resulting from Radiogenic Cancer per Rem of Absorbed Dose," Health Physics, Vol. 35, October 1978.

E. J. Hall, Radiation and Life, Pergamon Press, 1976.

B. L. Cohen and I. S. Lee, "A Catalog of Risks," Health Physics, Vol. 36, June 1979.

C. A. Kelsey, "Comparison of Relative Risk from Radiation Exposure and Other Common Hazards," Health Physics, Vol. 31, August 1978.

COMMUNITY MONITORING PROGRAM

FINAL EXAM

APRIL 1980

THEORY

3 pts. each

\_\_\_\_\_      \_\_\_\_\_  
true      false      For beta, gamma and x-ray radiation, a Rem is very nearly equal to a Rad which is very nearly equal to a Rem.

\_\_\_\_\_      The half-life of Krypton-85 is a) 30.4y; b) 10.7y; c) 8.08 days; d) 24,000 years.

\_\_\_\_\_      \_\_\_\_\_  
true      false      Krypton-85 is very biologically significant because it enters into the food chain.

\_\_\_\_\_      How many disintegrations per second occur in a Curie?  
a) 37  
b) 37 thousand  
c) 37 million  
d) 37 billion

\_\_\_\_\_      \_\_\_\_\_  
true      false      Different cells have different degrees of sensitivity to radiation.

\_\_\_\_\_      The special unit of activity is the  
a) Roentgen  
b) Rem  
c) Curie  
d) Photon

\_\_\_\_\_      The most radiosensitive age group in a human population is the  
a) fetus  
b) infant  
c) young child  
d) adolescent  
e) adult  
f) elderly

\_\_\_\_\_      The type radiation having the highest linear energy transfer and quality factor is the  
a) x-ray  
b) gamma ray  
c) beta  
d) alpha

true    false    An adequate barrier to stop alpha particles is a piece of paper.

                  
true    false    Half-life is the time required to reduce the activity of a pure radioactive sample by one half.

        
The radiation dose equivalent required to produce symptoms of radiation sickness, namely vomiting and diarrhea is

- a) 100 millirem
- b) 100 Rem
- c) 0.1 Rem
- d) 10 Rem

### PROCEDURES

          The readings should be taken at approximately

- a) 6 a.m.
- b) 6 p.m.
- c) high noon
- d) midnight

          If any high readings on the Ludlum exceed 125 cpm above the average background notify

- a) the TWG
- b) your local official
- c) the governor
- d) a and b
- d) b and c

          What is your action if you have a high reading greater than the average reading by more than 75 cpm on the Ludlum for 5 minutes or more?

- a) record the duration
- b) write N/A
- c) none of the above

          The tape should be scanned for any abnormalities. Any such abnormalities should be recorded in the comments section.

- a) true
- b) false

          To transmit the data, you must

- a) sign the monitoring report
- b) remove the community copy
- c) place the data in the Ludlum box
- d) a and b
- e) all of the above

\_\_\_\_\_ Approximately how many inches of LSI data should you collect each day?

- a) 60 inches
- b) 30 inches
- c) 80 inches
- d) 40 inches

\_\_\_\_\_ What is the radiation reading above background on the LSI, should you notify the TWG?

- a) .1 mr/hr
- b) .01 cpm
- c) 125 cpm
- d) .01 mr/hr

\_\_\_\_\_ Each day, you must place the following item(s) in the Ludlum box for transmittal to the TWG.

- a) LSI strip chart
- b) Ludlum strip chart
- c) community report
- d) the weather report
- e) all of the above
- f) a, b, and c

(9 pts.)

\_\_\_\_\_ On the attached figure 1, estimate the average, the high, and the low. (Note this is a Ludlum chart on the X10 range).

High \_\_\_\_\_ Low \_\_\_\_\_ Average \_\_\_\_\_

### INSTRUMENTS

\_\_\_\_\_ The scale on which the LSI is monitoring is determined by

- a) range switch
- b) indicator light
- c) line on chart
- d) none of the above

\_\_\_\_\_ The range of the Ludlum on the X1 scale is

- a) 0.004 to .4 mr/hr
- b) 0 - 1000 cpm
- c) 0 - 500 cpm
- d) 0 - 500 mr/hr

\_\_\_\_\_ How do you determine if the Rustrak recorder is operating properly?

- a) audible "clicks"
- b) ratemeter above zero
- c) recorder marking chart paper
- d) a and b
- e) a and c

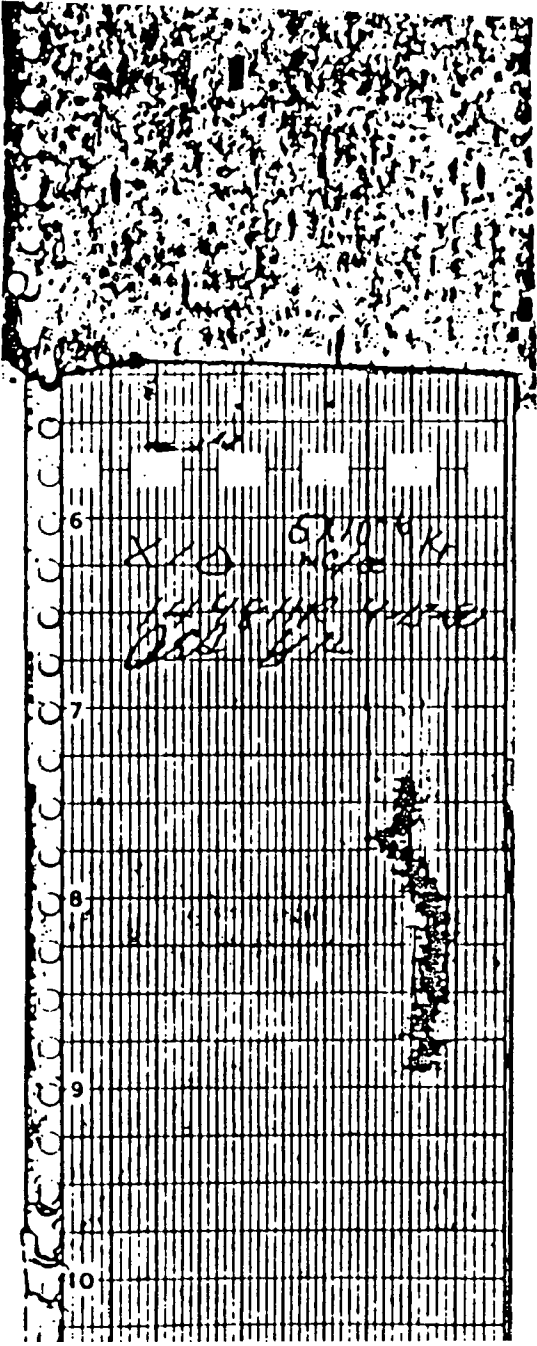



\_\_\_\_\_ The proper position for the response switch on the Ludlum is

- a) fast
- b) slow
- c) off
- d) intermediate

\_\_\_\_\_ The maximum reading of the Ludlum on the X10 range is

- a) 40 mr/hr
- b) 500 cpm
- c) 5000 cpm
- d) 10 mr/hr

\_\_\_\_\_ How many switches are on the LSI?

- a) 1
- b) 2
- c) 3

\_\_\_\_\_ With the Ludlum instrument on the X1 scale, the smallest scale division on the chart paper is

- a) 10 counts/min
- b) 100 counts/min
- c) 1000 counts/min
- d) none of the above

\_\_\_\_\_ Each time division (1/4 inch) on the Ludlum chart recorder equals

- a) 45 min
- b) 15 min
- c) 30 min
- d) 1 hour

\_\_\_\_\_ The LSI chart recorder advances at

- a) 1 inch/hr
- b) 5 inches/hr
- c) 3 inches/hr
- d) none of the above

\_\_\_\_\_ The full scale reading on the LSI X1 range is

- a) 500 cpm
- b) 40 mr/hr
- c) 0.4 mr/hr

\_\_\_\_\_ The pancake probe used with the Ludlum is

- a) scintillation counter
- b) gieger mueller tube
- c) proportional counter
- d) thermocouple

# SCRIPT TO ACCOMPANY SLIDE PRESENTATION

ON

## LOW LEVEL RADIATION

THIS SCRIPT IS PROVIDED TO ASSIST IN THE PRESENTATION OF THE NSPE SLIDE PROGRAM ON LOW LEVEL RADIATION. IT PROVIDES AN ORAL EXPLANATION OF EACH SLIDE. INDIVIDUALS WITH SUFFICIENT KNOWLEDGE ARE ENCOURAGED TO EXPAND ON THE CONTENTS OF THE SCRIPT. IT IS RECOMMENDED, HOWEVER, THAT SLIDES BE ADVANCED AT A SUFFICIENTLY RAPID RATE TO KEEP THE VIEWERS' INTEREST. EXCESSIVELY LONG EXPLANATIONS SHOULD BE AVOIDED.

### SLIDE ONE

THIS PUBLIC EDUCATION PROGRAM IS PRESENTED BY THE (INSERT CHAPTER, STATE SOCIETY OR OTHER AFFILIATION) AND THE NATIONAL SOCIETY OF PROFESSIONAL ENGINEERS, A NONPROFIT ORGANIZATION REPRESENTING APPROXIMATELY 80,000 INDIVIDUAL MEMBERS WHO ARE ACTIVE IN VIRTUALLY EVERY ASPECT OF ENGINEERING. THE PURPOSE OF THIS PRESENTATION IS TO GIVE THE VIEWER A BETTER UNDERSTANDING OF THE SOURCES AND EFFECTS OF LOW LEVEL RADIATION.

February, 1980

## SLIDE TWO

EVERY LIVING THING ON THIS PLANET IS EXPOSED TO RADIATION. ALL HUMAN BEINGS RECEIVE VARYING AMOUNTS OF RADIATION EXPOSURE THROUGHOUT THEIR ENTIRE LIFETIMES. WE IN THIS ROOM ARE, AT THIS VERY MOMENT, RECEIVING THE STANDARD BACKGROUND LEVELS OF RADIATION COMMON TO THIS LOCATION. THAT LEVEL AND ITS PREDICTED EFFECT ON YOU WILL BE EXPLAINED DURING THIS PRESENTATION.

## SLIDE THREE

LOW LEVEL IONIZING RADIATION SHOULD BE A PRIMARY CONCERN TO ALL. IT IS IMPORTANT TO KNOW WHAT IT IS, WHERE IT COMES FROM, AND WHAT ITS HEALTH EFFECTS ARE.

FOR THE PURPOSES OF THIS PRESENTATION, IONIZING RADIATION MEANS THAT RADIATION WHICH IS CAUSED BY THE DECAY OF RADIOACTIVE MATERIALS THAT OCCUR IN NATURE OR COME FROM MAN-MADE SOURCES, BOTH OF WHICH HAVE THE POTENTIAL TO DESTROY OR OTHERWISE AFFECT LIVING TISSUE. THIS PRESENTATION WILL NOT EXAMINE RADIO WAVES RADIATION, WHICH INCLUDE MICROWAVES LIKE THOSE USED IN CERTAIN OVENS, OR OTHER TYPES OF RADIATION.

## SLIDE FOUR

THIS IS A GRAPHIC DISPLAY OF THE ANNUAL RADIATION EXPOSURE RATE FOR THE AVERAGE UNITED STATES CITIZEN. YOU WILL NOTE THAT THE AVERAGE RATE IS 100 TO 200 MILLIREMS PER YEAR DEPENDING ON WHERE AND HOW YOU LIVE. OF THAT AMOUNT, NATURALLY OCCURRING RADIATION, THAT WHICH COMES FROM COSMIC RAYS, TRACE ELEMENTS IN THE SOIL, AND THE HUMAN BODY, TOTALS APPROXIMATELY 92 TO 97 MILLIREMS, WHILE MAN-MADE RADIATION, THAT WHICH COMES FROM ENERGY PRODUCTION, MEDICAL DIAGNOSIS, AND WEAPONS TESTING FALLOUT, TOTALS APPROXIMATELY 80 MILLIREMS.

THE LARGEST SINGLE AMOUNT OF EXPOSURE, 70 MILLIREMS, COMES FROM MEDICAL AND DENTAL DIAGNOSIS. THIS INCLUDES X-RAY MACHINES AND THE USE OF RADIO PHARMACEUTICALS.

THE SMALLEST AMOUNT OF EXPOSURE, 3 MILLIREMS, COMES FROM ENERGY PRODUCTION AND USE. ALSO, YOU WILL NOTE THAT HUMAN BEINGS RADIATE THEMSELVES -- 22 TO 27 MILLIREMS COME FROM THE POTASSIUM 40 AND CARBON 14 CONTAINED IN OUR BODIES.

THIS SLIDE HAS INTRODUCED A NEW TERM -- "MILLIREM". THIS WORD IS USED BY SCIENTISTS TO MEASURE THE AMOUNT OF RADIATION EXPOSURE TO THE HUMAN BODY. THE TERM "MILLIREM" IS USED CONSISTENTLY THROUGHOUT THIS PRESENTATION WHEN MEASURING RADIATION EXPOSURE.

#### SLIDE FIVE

THE MAP OF THE UNITED STATES SHOWS THE AVERAGE NATURAL RADIATION BACKGROUND LEVEL FOR EACH STATE. THE VARIATION IN LEVELS IS CAUSED PRIMARILY BY DIFFERENT ALTITUDES AND NATURAL ROCK FORMATIONS CONTAINING TRACES OF URANIUM OR THORIUM.

THE STATES THAT ARE COLORED PINK, THE ROCKY MOUNTAIN STATES, HAVE THE HIGHEST LEVEL OF NATURAL BACKGROUND RADIATION PRIMARILY BECAUSE OF THEIR HIGHER ALTITUDE. THESE STATES ARE EXPOSED TO MORE COSMIC RADIATION THAN ARE STATES WITH LOWER ALTITUDES. THE STATES COLORED GREEN HAVE THE LOWEST RADIATION LEVELS, WHILE THE YELLOW COLORED STATES ARE IN BETWEEN. THE NATURAL BACKGROUND LEVEL FOR (INSERT YOUR STATE) IS (INSERT RADIATION LEVEL SHOWN ON MAP).

#### SLIDE SIX

THE NEXT FEW SLIDES IDENTIFY SEVERAL SOURCES OF BACKGROUND RADIATION WHICH OCCUR IN ADDITION TO THE NATURAL BACKGROUND EXPOSURE. REMEMBER, MINIMUM NATURAL BACKGROUND RADIATION LEVEL IS APPROXIMATELY 100 MILLIREMS PER YEAR.

### SLIDE SEVEN

IT IS INTERESTING TO NOTE THAT OUR LAWMAKERS WORKING IN WASHINGTON, D.C. RECEIVE AN ADDITIONAL RADIATION DOSAGE OF 20 MILLIREMS PER WORKING YEAR. THIS IS DUE TO THE RADIOACTIVE ELEMENTS IN THE STONE USED IN THE UNITED STATES CAPITOL.

### SLIDE EIGHT

AT GRAND CENTRAL STATION'S VANDERBILT STREET ENTRANCE, THE RADIATION LEVEL IS 500 MILLIREMS PER YEAR. THIS IS AROUND-THE-CLOCK EXPOSURE -- 365 DAYS A YEAR, 24 HOURS A DAY. OBVIOUSLY, IT IS LESS WHEN LOCATED THERE ONLY 40 HOURS PER WEEK. FOR A BAGGAGE HANDLER OR OTHER PERSONS LOCATED THERE REGULARLY, THE EXPOSURE LEVEL IS 120 MILLIREMS PER WORKING YEAR.

### SLIDE NINE

A PERSON TRAVELING ON A TRANSCONTINENTAL FLIGHT AT AN ALTITUDE ABOVE 33,000 FEET IS EXPOSED TO APPROXIMATELY 3 TO 5 MILLIREMS PER TRIP. THIS IS MORE THAN YOU WOULD RECEIVE IF YOU SPENT 24 HOURS A DAY AT THE GATE HOUSE OF A NUCLEAR POWER PLANT FOR AN ENTIRE YEAR.

### SLIDE TEN

YOU ARE ALL FAMILIAR WITH THOSE ALCOHOL AND PROPANE LANTERNS WHICH USE MANTLES TO PRODUCE A HIGH INTENSITY LIGHT. THE ADDITIONAL RADIATION EXPOSURE LEVEL FROM ONE OF THESE MANTLES, WHEN PLACED IN THE CELLAR OF A WOODEN HOUSE, IS 5 TO 20 MILLIREMS PER YEAR, DEPENDING ON WHERE THE LANTERN IS LOCATED IN THE CELLAR. AND IT DOESN'T MATTER WHETHER THE LANTERN IS BURNING OR NOT.

### SLIDE ELEVEN

YOU WOULD SUSPECT THAT AS YOU GET CLOSER TO A MAN-MADE SOURCE OF RADIATION THERE WOULD BE GREATER EXPOSURE ABOVE THE NATURAL BACKGROUND LEVEL. IT FOLLOWS THEN, THAT YOU MIGHT ASSUME THAT THE RADIATION EXPOSURE RATE FOR A PERSON WORKING 2,000 HOURS A YEAR IN THE OPERATING ROOM OF A NUCLEAR POWER PLANT WOULD BE QUITE HIGH. IN FACT, THE EXPOSURE RATE FOR SUCH A PERSON IS 50 MILLIREMS. THIS IS LESS THAN THAT RECEIVED ANNUALLY BY AN X-RAY TECHNICIAN.

### SLIDE TWELVE

ADMIRAL RICKOVER REPORTS THAT A NUCLEAR SUBMARINE CREW IS EXPOSED TO 250 MILLIREMS OF LOW LEVEL RADIATION EACH YEAR.

### SLIDE THIRTEEN

THE EXPOSURE RATE FOR A PERSON LOCATED AT THE GATE HOUSE OF A NUCLEAR POWER PLANT IS LOWER THAN MIGHT BE IMAGINED. THE AVERAGE EXPOSURE RATE IS 1 MILLIREM PER YEAR. FAR LESS THAN FOR A PERSON WORKING IN THE U.S. CAPITOL OR GRAND CENTRAL STATION.

### SLIDE FOURTEEN

AS PREVIOUSLY NOTED, RADIATION TRACE ELEMENTS ARE PRESENT IN CERTAIN ROCKS AND ROCK FORMATIONS. THESE ELEMENTS, USUALLY PRESENT IN GRANITE, INCREASE THE EXPOSURE LEVEL FOR A PERSON LIVING NEAR A GRANITE ROCK FORMATION BY 25 TO 100 MILLIREMS A YEAR.

### SLIDE FIFTEEN

THE DOSAGE RATE ASSOCIATED WITH PASSING A NUCLEAR WASTE TRUCK IS, OF COURSE, NOT DETERMINED ON THE BASIS OF MILLIREMS OF EXPOSURE PER YEAR BUT RATHER ON THE SINGLE TOTAL DOSAGE RECEIVED EACH TIME YOU PASS SUCH A TRUCK. WHEN PASSING A NUCLEAR WASTE TRUCK AT A SPEED

EXCEEDING THE TRUCK'S SPEED BY 20 MILES PER HOUR, THE RADIATION EXPOSURE RATE IS .01 (1/100TH) OF A MILLIREM PER PASS.

#### SLIDE SIXTEEN

SLEEPING WITH ANOTHER PERSON INCREASES THE ANNUAL RADIATION EXPOSURE LEVEL FOR THE AVERAGE UNITED STATES CITIZEN BY .1 (1/10TH) OF A MILLIREM. THIS IS BECAUSE THE POTASSIUM 40 AND CARBON 14 PRESENT IN THE HUMAN BODY RADIATE THOSE PERSONS WITH WHOM WE SLEEP. THE INCREASED RADIATION EXPOSURE, DUE TO THIS MOST "HAZARDOUS" ACTIVITY, EXCEEDS BY TEN TIMES THE DOSAGE RECEIVED FROM PASSING A NUCLEAR WASTE TRUCK.

#### SLIDE SEVENTEEN

AS PREVIOUSLY MENTIONED, AN X-RAY TECHNICIAN, ACCORDING TO THE NATIONAL INSTITUTES OF HEALTH, IS EXPOSED TO 51 MILLIREMS OF RADIATION PER YEAR. THIS IS A LARGER DOSAGE OF RADIATION THAN IS RECEIVED BY A PERSON WORKING FOR A YEAR IN A NUCLEAR POWER PLANT OPERATING ROOM.

#### SLIDE EIGHTEEN

IT HAS BEEN DETERMINED BY THE ENVIRONMENTAL PROTECTION AGENCY THAT PERSONS LIVING IN COLORADO RECEIVE AN ADDITIONAL RADIATION DOSAGE OF 70 TO 90 MILLIREMS A YEAR.

#### SLIDE NINETEEN

WHAT HAVE WE JUST LEARNED? HOW DO THESE FACTS RELATE TO EACH OTHER AND WHAT IS THEIR EFFECT ON US?

THE NEXT FEW SLIDES WILL ANSWER THESE QUESTIONS BY LOOKING AT THE WHOLE SPECTRUM OF RADIATION, STARTING WITH THE HIGHEST CONCEIVABLE RADIATION EXPOSURE THAT HUMANS MIGHT BE SUBJECTED TO AND WORK-

ING DOWN TO THE LOWER LEVELS WHICH CONFRONT US DAILY. YOU MAY DRAW YOUR OWN CONCLUSIONS ABOUT JUST HOW FRIGHTENED YOU OUGHT TO BE ABOUT RADIATION AS IT OCCURS IN NATURE OR IS DERIVED FROM TECHNOLOGY.

#### SLIDE TWENTY

THIS FIRST CHART SHOWS THE HIGHEST CONCEIVABLE LEVEL OF RADIATION EXPOSURE THAT IS KNOWN TO MAN. THAT DOSAGE RATE, 5 MILLION MILLIREMS IS CAUSED BY A SERIES OF THERAPEUTIC X-RAYS TO A SINGLE ORGAN. THIS GENERALLY IS THE KIND OF RADIATION USED IN MEDICAL TECHNOLOGY WHEN TREATING A CANCER PATIENT. IT IS CAREFULLY FOCUSED ON A VERY SMALL REGION OF THE BODY. A WHOLE BODY EXPOSURE OF THIS MAGNITUDE WOULD LEAD TO DEATH.

#### SLIDE TWENTY-ONE

THE LETHAL DOSAGE RATE FOR WHOLE BODY RADIATION EXPOSURE IS 400,000 TO 500,000 MILLIREMS. THE ONLY WAY TO RECEIVE SUCH A DOSAGE IS TO BE LOCATED A FEW HUNDRED YARDS FROM GROUND ZERO OF A NUCLEAR WEAPON EXPLOSION.

#### SLIDE TWENTY-TWO

THE FIRST DETECTABLE PHYSIOLOGICAL IMPACT ON HUMANS AS A RESULT OF RADIATION EXPOSURE IS FOUND IN THE 25,000 TO 50,000 MILLIREMS RANGE. THIS IS STILL A LARGE DOSAGE AMOUNT AND IS EQUIVALENT TO TEN TIMES THE PERMISSIBLE ANNUAL EXPOSURE RATE FOR AN INDUSTRIAL WORKER.

#### SLIDE TWENTY-THREE

THE THREE CHARTS WHICH WE HAVE JUST SEEN IDENTIFY RADIATION SOURCES WHICH ARE KNOWN AS "HIGH LEVEL" SOURCES OF RADIATION. THIS CHART, AND THE NEXT THREE, LOOK AT THOSE "LOW LEVEL" SOURCES OF RADIATION WHICH ARE THE SUBJECT OF THIS PRESENTATION.

THE MAXIMUM ALLOWABLE ANNUAL EXPOSURE RATE FOR AN INDUSTRIAL



WORKER IS 5,000 MILLIREMS PER YEAR. THIS IS A LARGE DOSE OF RADIATION COMPARED TO BACKGROUND BUT MANY SCIENTISTS, AND THEY DON'T ALL AGREE, AND THE FEDERAL REGULATORY AGENCIES PERMIT THAT LEVEL OF EXPOSURE FOR A WORKER.

#### SLIDE TWENTY-FOUR

LET US NOW LOOK AT THOSE SOURCES OF LOW LEVEL RADIATION WHICH WE ARE REASONABLY EXPECTED TO LIVE WITH IN OUR EVERYDAY LIVES. IN THE RANGE OF 50 TO 500 MILLIREMS PER YEAR YOU BEGIN TO SEE THE NATURAL BACKGROUND AND OCCUPATIONAL SOURCES.

FOR EXAMPLE, TRANSCONTINENTAL FLIGHT CREWS ARE EXPOSED TO AN ADDITIONAL 385 MILLIREMS PER YEAR. FOR ALL OCCUPATIONS RELATED TO THE PRODUCTION OF NUCLEAR POWER, THE ANNUAL DOSAGE RATE IS 365 MILLIREMS; THIS OCCUPATIONAL CATEGORY INCLUDES THOSE PERSONS INVOLVED IN URANIUM MINING, PROCESSING AND SMELTING, CONSTRUCTION WORK, POWER PLANT OPERATIONS AND OTHER RELATED ACTIVITIES.

THE MAXIMUM ADDITIONAL EXPOSURE THAT AN OFF-SITE INDIVIDUAL COULD HAVE RECEIVED DURING THE CRITICAL PERIOD OF THE THREE MILE ISLAND ACCIDENT WAS 83 MILLIREMS. THIS RATE IS LESS THAN THE AVERAGE U.S. NATURAL BACKGROUND RATE.

FINALLY, MEDICAL AND DENTAL DIAGNOSES HAVE A RATE OF 70 MILLIREMS ANNUALLY.

#### SLIDE TWENTY-FIVE

IN THE 5-TO-50 MILLIREMS LEVEL WE FIND THE THREE SOURCES OF NATURAL BACKGROUND RADIATION. COSMIC RAYS AND TERRESTRIAL SOURCES TOTAL 35 MILLIREMS EACH. THE RADIONUCLIDES IN THE BODY EQUAL 22 TO 27 MILLIREMS.

FINALLY, WORKING IN THE U.S. CAPITOL EQUALS 20 MILLIREMS PER YEAR. FOR THOSE OF YOU WHO ARE FAMILIAR WITH CAPITOL HILL, THE DOSAGE RATE AT THE WEST DOOR OF THE LIBRARY OF CONGRESS IS 79 MILLIREMS PER YEAR, WHILE A RATE OF 48 MILLIREMS PER YEAR EXISTS AT THE ENTRANCE TO THE RAYBURN HOUSE OFFICE BUILDING.

#### SLIDE TWENTY-SIX

THIS LAST CHART SHOWS THOSE RADIATION SOURCES WITH AN ANNUAL EXPOSURE RATE OF LESS THAN FIVE MILLIREMS. FALLOUT FROM NUCLEAR WEAPONS IS 4.4. NATURAL GAS, ESPECIALLY THAT USED IN OUR HOMES, IS 2. THE AVERAGE TOTAL EXPOSURE FOR THOSE PERSONS LIVING WITHIN A 50-MILE RADIUS OF THREE MILE ISLAND DURING MARCH 28 TO APRIL 7, 1979 WAS 1.5 MILLIREMS. THE PREDICTED 1980 RADIATION EXPOSURE RATE FOR NUCLEAR POWER IS .1 (1/10TH) OF A MILLIREM. THIS IS THE SAME AS SLEEPING WITH ANOTHER HUMAN BEING. FINALLY, CONSUMER PRODUCTS, INCLUDING TELEVISIONS, HAVE A RADIATION EXPOSURE RATE OF .03 (3/100TH) OF A MILLIREM.

#### SLIDE TWENTY-SEVEN

THE NEXT TWO SLIDES WILL INDICATE THE PREDICTED CANCER FATALITY RATES ASSOCIATED WITH LOW LEVEL RADIATION EXPOSURE.

IN THE FOLLOWING DISCUSSION, PLEASE KEEP IN MIND THAT THE TOTAL NUMBER OF CANCER FATALITIES PER YEAR IN THE UNITED STATES, DUE TO ALL CAUSES, IS CURRENTLY ABOUT 400,000. THE NUMBER OF ANNUAL FATALITIES THAT ARE PREDICTED TO BE ASSOCIATED WITH LOW LEVEL RADIATION IS SUCH A SMALL PERCENTAGE OF THE TOTAL OF 400,000 THAT IT IS IMPOSSIBLE TO MEASURE THIS EFFECT IN THE POPULATION. THIS IS BECAUSE ANY POSSIBLE CONTRIBUTION TO THE FATALITY RATE FROM LOW LEVEL RADIATION IS EVEN LESS THAN THE YEAR-TO-YEAR VARIATION IN THE TOTAL NUMBER OF CANCER FATALITIES.

SO OUR DISCUSSION OF CANCER FATALITIES IS BASED ON STATISTICAL PREDICTIONS AND NOT ON ACTUAL MORTALITY DATA. WHEN WE TALK ABOUT POPULATION EXPOSURE TO LOW LEVEL RADIATION, WE USE A PURELY STATISTICAL QUANTITY CALLED THE "PERSON-REM."

ONE PERSON-REM IS EQUIVALENT TO ONE PERSON RECEIVING A RADIATION DOSE OF ONE REM OR ONE THOUSAND MILLIREMS. IT IS ALSO EQUIVALENT TO TWO PEOPLE, EACH RECEIVING A DOSE OF ONE-HALF REM -- OR FOUR PEOPLE, EACH RECEIVING ONE-QUARTER REM AND SO ON.

THE SCIENTIFIC COMMUNITY ASSUMES, STATISTICALLY SPEAKING, THAT WHEN A POPULATION IS EXPOSED TO 5,000 PERSON-REMS OF IONIZING RADIATION THAT, IN TURN, WILL PRODUCE ONE CANCER FATALITY. BASED ON THAT ASSUMPTION, THE FOLLOWING PREDICTIONS ARE MADE ABOUT THE TOTAL GENERAL U.S. POPULATION ON AN ANNUAL BASIS:

1. 3080 FATALITIES OCCUR AS A RESULT OF MEDICAL AND DENTAL RADIATION EXPOSURE;
2. THAT SAME NUMBER OCCURS AS A RESULT OF COSMIC AND TERRESTRIAL RADIATION EXPOSURE;
3. 880 FATALITIES ARE DIRECTLY RELATED TO POTASSIUM 40 IN OUR FOOD;
4. 194 FATALITIES RESULT FROM NUCLEAR WEAPONS FALLOUT;
5. 133 FATALITIES AS A RESULT OF THE USE OF NATURAL GAS AND THE BURNING OF COAL;
6. 4.4 FATALITIES OCCUR FROM RADIATION EXPOSURE RESULTING FROM SLEEPING WITH ANOTHER HUMAN;
7. THE SAME NUMBER OF FATALITIES ARE CAUSED BY RADIATION EXPOSURE FROM NUCLEAR POWER; AND
8. 1.3 FATALITIES AS A RESULT OF RADIATION EXPOSURE FROM CONSUMER PRODUCTS.

THUS, THERE ARE, IN THE UNITED STATES, ABOUT 7,400 PREDICTED FATALITIES PER YEAR DUE TO IONIZING RADIATION EXPOSURE, WHICH IS LESS THAN 2 PERCENT OF ANNUAL CANCER FATALITIES DUE TO ALL CAUSES.

### SLIDE TWENTY-EIGHT

THIS SLIDE PROVIDES SIMILAR PREDICTIONS FOR SPECIAL GROUPS IN THE UNITED STATES. PLEASE NOTE, HOWEVER, THAT THE NUMBER OF PREDICTED FATALITIES IS EXPRESSED IN A NUMBER OF FATALITIES PER MILLION PERSONS PER YEAR.

FOR EXAMPLE, THERE ARE 77 YEARLY FATALITIES PREDICTED FOR EACH MILLION PERSONS WHO SERVE AS CREW MEMBERS ON TRANSCONTINENTAL JETS.

IT IS INTERESTING TO NOTE THAT THE PREDICTED 16 FATALITIES FOR EACH MILLION PERSONS LIVING IN COLORADO IS FAR GREATER THAN THE PREDICTION FOR FATALITIES RESULTING FROM THE THREE MILE ISLAND ACCIDENT OR FROM THE OCCUPATION GROUP OF NUCLEAR POWER PLANT GUARDS. EACH OF THESE TWO GROUPS HAVE A FATALITY PREDICTION RATE OF LESS THAN ONE PERSON PER MILLION.

### SLIDE TWENTY-NINE

THE STATISTICAL DATA AND OTHER INFORMATION USED IN THIS PRESENTATION WERE COMPILED BY REPRESENTATIVE MIKE MCCORMACK. MR. MCCORMACK IS CHAIRMAN OF THE HOUSE OF REPRESENTATIVES SUBCOMMITTEE ON ENERGY RESEARCH AND PRODUCTION OF THE COMMITTEE ON SCIENCE AND TECHNOLOGY.

### SLIDE THIRTY

THE (INSERT CHAPTER, STATE SOCIETY OR OTHER AFFILIATION) AND THE NATIONAL SOCIETY OF PROFESSIONAL ENGINEERS HOPE THAT YOU HAVE FOUND THIS PRESENTATION INFORMATIVE. ADDITIONAL INFORMATION ON THE SUBJECT OF LOW LEVEL RADIATION IS AVAILABLE FROM NSPE. WE ENCOURAGE COMMENTS OR OBSERVATIONS CONCERNING THIS PRESENTATION AND WAYS THAT IT CAN BE IMPROVED.

THANK YOU.

## INTRODUCTION

The Breazeale Nuclear Reactor emits radiation during normal operation. The resulting radiation includes neutrons and gamma rays. Most of the radiation is stopped in the pool water. A very small amount escapes into the reactor bay. In addition, a number of gaseous radionuclides are created by various nuclear reactions. Most notably, these radionuclides include  $N^{14}$  and  $Ar^{41}$ .

It is the purpose of this laboratory exercise to study the changes in radiation levels and to become familiar with the equipment used in the Citizen Monitoring Program. To accomplish this, the participants will observe the background radiation levels with the reactor shutdown and operating. In addition, at the end of the experiment the reactor will be pulsed to allow observation of the radiation levels during and after the pulse.

## EXPERIMENTAL PROCEDURE

### Part 1: Setup and Background Measurement

1. Plug in the power cords for the Ludlum, Model 177 Alarm Rate Meter, the Rustrak Recorder, and the Lear Siegler Ionization Chamber (LSI).
2. For the Ludlum, set the range switch to "x1", its response switch to slow, and the power to ON. Observe that the red light comes on. Also observe the chart recorder "clicks."
3. Allow 30 seconds for equipment to stabilize, then pull down the recorder window and record the time you started, the date, your community and your signature. Roll out additional chart paper if required.
4. Being sure that no radioactive sources are immediately adjacent to the detector allow the instrument to record background for approximately 1 hour.
5. For the Lear Siegler Ionization Chamber, switch the mode switch from off to operate. Observe that the pointer on the recorder deflects sharply to the right as the machine automatically changes scale.
6. Allow the LSI instrument to stabilize for 2 minutes, then open the recorder window. Record the time you started, the date, your community, and your signature.
7. Being sure that no radioactive sources are immediately adjacent to the detector, allow the instrument to record background for approximately 1 hour.
8. At the end of the 1 hour time period, advance the tape until the trace is completely out of the recorder. Again, open the window and record the time, date, your community and your signature. Do this for both the Ludlum and LSI.

9. Using the data sheets provided, each member of the group should record the date, start and stop time, and your community. From the points on the tapes, each member should determine and record on the data sheets the following:

Ludlum	LSI
Maximum count rate	Maximum radiation level
Minimum count rate	Minimum radiation level
Average count rate	Average level
Your signature	

10. Review your findings with your instructor.

QUESTION: Can you explain the variation in background? Briefly describe the reason below.

Part II: Measurement of Radiation Levels in Reactor Bay

1. Observe that the Ludlum and the Lear Siegler Ionization (LSI) chamber are both operating. Check the Ludlum power light to ensure it is lighted. Check for "clicks" from the two chart recorders to ensure they are operating. Check to see if the Ludlum is reading on scale. Adjust the range switch on the Ludlum to obtain an onscale reading if required.
2. Using the thumbwheel, advance the charts on both the Ludlum and LSI recorders. Pull down the recorder window and record the time you started, the date, your community, reactor power level, and your signature. Roll out additional chart paper if required.
3. Allow the instruments to run for 10 minutes. At the end of the 10-minute counting period, using the wheel on the recorder face, advance the tape until the trace is completely out of the recorder. Pull down the recorder window and record the time you ended, the date, your community, reactor power level, and your signature. Roll out additional chart paper if required. Do this for both the Ludlum and LSI recorders.
4. From the points on the tape, each member of the group should determine and record the following information:

Ludlum	LSI
Maximum count rate	Maximum radiation level
Minimum count rate	Minimum radiation level
Average count rate	Average radiation level

Date, time start and end, reactor power level, your signature and community

QUESTION: Are the levels increasing, decreasing, or remaining the same?

Appendix C

Program Operating Procedures

## OPERATING PROCEDURES - CITIZEN MONITOR

NOTE: The Ludlum Model 177 Alarm Rate Meter, Eberline Model 260 pancake probe, and Rustrak Recorder will be referred to in these procedures as - Ludlum detector. The Lear Siegler Ionization Chamber will be referred to as the - LSI.

To insure accurate and reliable data, these procedures are to be followed without deviation. No changes or deviations are allowed unless approved by a member of the Technical Working Group (TWG).

### I. LUDLUM CHECKOUT DURING PERIODIC MONITORING:

1. Unlock the Ludlum instrument box using the key provided.
2. Inspect the Ludlum system for any signs of damage. Check the following:
  - a. Power on light is lighted
  - b. Audible "clicks" from recorder
  - c. Rate meter reading above zero
  - d. Recorder marking chart paper
  - e. Range switch in X1 position
  - f. Response switch in slow
3. If any of the above items appear incorrect proceed to section "In Case of Trouble." Otherwise, go to following section.

### II. COLLECTION OF DATA-LUDLUM

1. If the equipment is being started for the first time, go to step 6. Otherwise, proceed to step 2.
2. If the equipment is operating properly, advance the recorder until approximately 4 inches of clear paper are exposed from the machine.
3. Stamp the front of the paper using the rubber stamp provided.
4. Record date, time of stop, and your signature.



5. Tear off the strip chart even with the top of the recorder. Be careful not to cause the paper inside the recorder to be disturbed.
6. Advance the chart paper 4 inches from the recorder.
7. Stamp the front of the paper using the rubber stamp provided.
8. Record date, time of start and your signature.
9. You should now have approximately 3<sup>2</sup> inches of chart paper with a stamp at either end.
10. Remove the chart paper, a Citizen Radiation Monitoring Program Monitoring Report Form.
11. Close the box and place data aside but do not lock the box at this time.
12. Proceed to the next section.

### III. LSI CHECKOUT DURING PERIODIC MONITORING

1. Open the LSI suitcase.
2. Inspect the LSI for any signs of damage. Check for the following:
  - a. Selector switch is ON
  - b. Audible "clicks" from recorder
  - c. Recorder reading above zero
  - d. Recorder marking paper
3. If any of the above items appear incorrect, proceed to section "In case of Trouble." Otherwise, go to the following section.

### IV. COLLECTION OF DATA - LSI

1. If the equipment is being started for the first time, go to step 6. Otherwise proceed to step 2.
2. If the equipment is operating properly, advance the recorder until approximately 4 inches of clear paper are exposed from the machine.
3. Stamp the front of the paper using the rubber stamp provided.
4. Record date, stop time, and signature.
5. Tear off the strip chart even with the top of the recorder. Be careful not to cause the paper inside the recorder to be disturbed.

6. Advance the chart paper 4 inches from the recorder.
7. Stamp the front of the paper using the rubber stamp provided.
8. Record date, start time, and signature.
9. You should now have approximately 80 inches of chart paper with a stamp at either end.
10. Remove the chart paper and close the suitcase.

V. DATA INTERPRETATION - LUDLUM

1. Pickup the Ludlum data and set the LSI data aside for later review.

NOTE: The Ludlum chart recorder advances at 1 inch per hour. Each time division (1/4 inch) equals 15 min.

NOTE: With the instrument on the XI scale, the full scale reading is 500 counts/min. The smallest scale division is therefore 10 counts/min.

2. Record the "Time On" from the beginning of the chart and the time of reading on the Monitoring report.
3. Scan the tape note the high reading and the low reading. (See Figure 1 attached for definition).
4. Estimate the average reading.
5. If the high reading is greater than the average reading by more than 75 cpm estimate and record the duration. Otherwise indicate not applicable "N/A".
6. Scan the tape for any abnormalities, i.e. "spikes", "glitches", or high readings. Note in the comments section any such indications. (See Figure 2 for samples of these).
7. If any high readings exceed 125 cpm above the average background, notify the TWG at (tel. #) immediately and request assistance. Notify your local official.
8. Set the Ludlum data aside. Proceed to the next section.

VI. DATA INTERPRETATION - LSI

NOTE: The LSI Chart Recorder advances at 3 inches per hour. Each time division (1/4 inch) equals 5 min.

NOTE: The instrument is dual range and automatically switches ranges.

NOTE: The range is indicated by the line drawn on the paper as either X1 or X100 (See Figure 3).

NOTE: Full scale on the X1 range is 0.4 mr/hr. Readings must be between 0.004 mr/hr and 0.4 mr/hr.

NOTE: Full scale on the X100 range is 40 mr/hr. Readings must be between 0.4 mr/hr and 40 mr/hr.

1. Record the "Time ON" from the beginning of the chart and the time of reading on the monitoring report.
2. Scan the tape note the high reading and low reading (See Figure 3 for definition).
3. Estimate the average reading.
4. If the high reading is greater than the average reading by .01 mr/hr estimate and record the duration. Otherwise indicate not applicable "N/A".
5. Scan the tape for any abnormalities, i.e., spikes, glitches, or high readings. Note in the comments section any such indications. (See Figure 4 for samples of these).
6. If any high readings exceed the average background, by .01 mr/hr notify the TWG at (tel. #) immediately and request assistance. Notify your local official.

VII. DATA TRANSMITTAL

1. Sign the Monitoring Report.
2. Remove the community copy of your Monitoring Report.

3. Open the Ludlum box. Place the Ludlum Data, LSI Data, and the original monitoring report for that day in the box and remove the previous day's data and report.
4. Close the Ludlum box and lock it.
5. Take the previous day's data, the TWG summary sheet, and the community copy to the place designated by your local official.

OPERATING PROCEDURE - CIRCUIT RIDER.

1. Proceed to Monitoring Locations designated by TWG and indicated on the circuit rider log sheet.
2. Unlock the Ludlum box.
3. Remove current data consisting of 2 strip charts, one short (30 inches) and one long (80 inches). Remove current monitoring report.
4. If data is not available, note on circuit rider log sheet that data for that day was not available.
5. Place the previous day's data in the Ludlum box.
6. Close the box and lock it.
7. Proceed to next monitoring location.
8. After last location, proceed to Middletown Borough Hall for data drop and pickup.
9. At the Borough Hall, place the current day's data in the appropriate box. Pick up previous day's data.

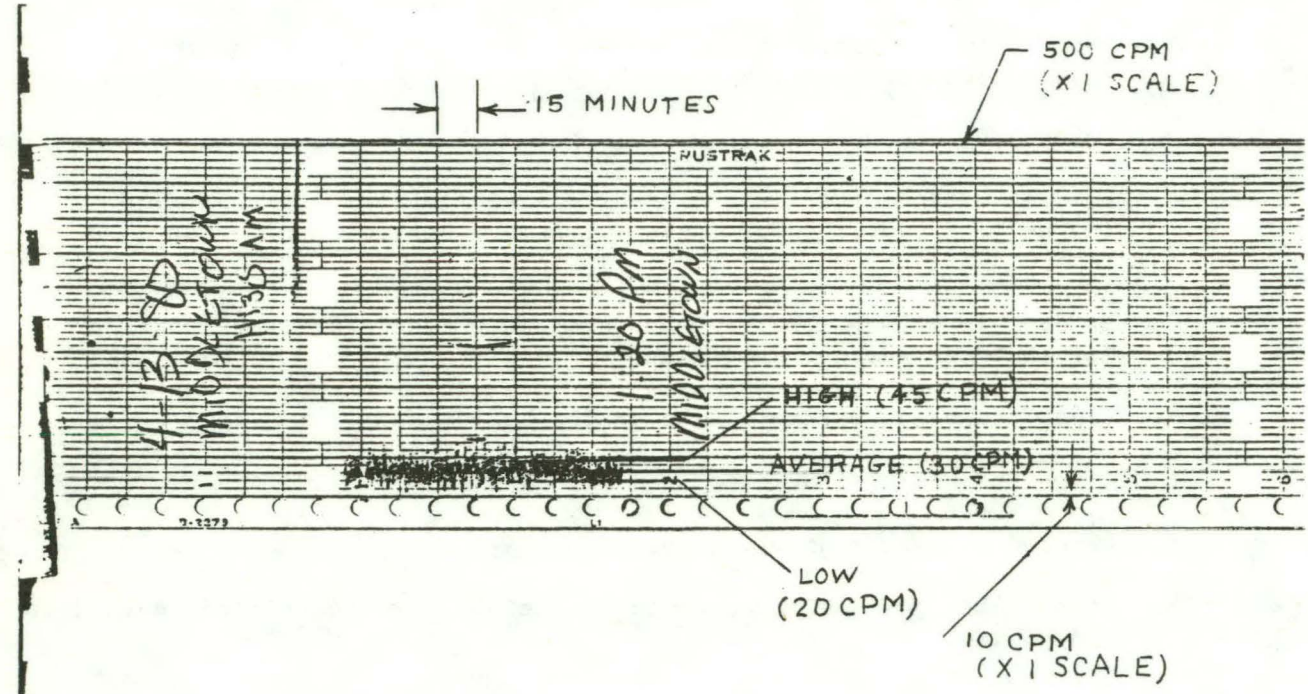

FIG 1.  
LUDLUM CHART OUTPUT  
(BACKGROUND)

"GLITCH"—FAULTY RECORDER CABLE

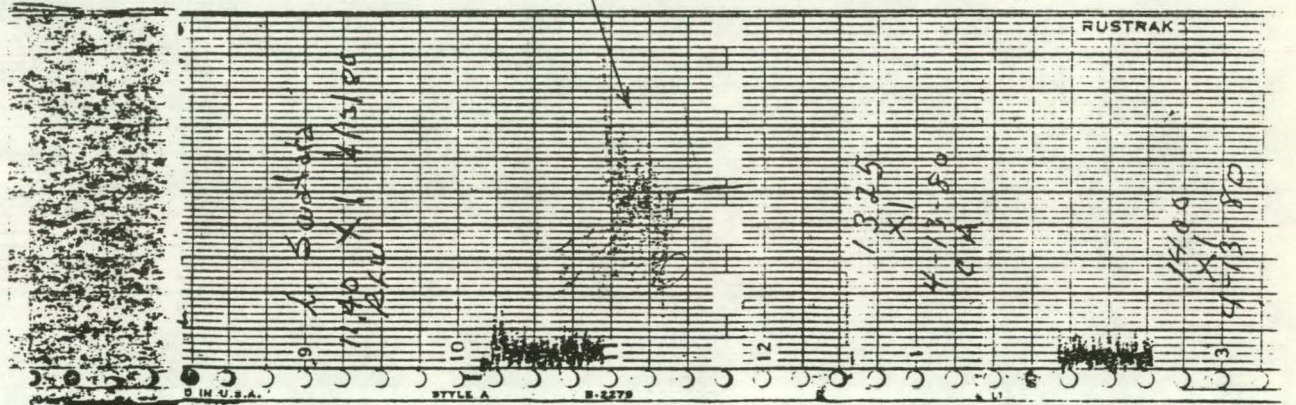

FIG. 2

LUDLUM "GLITCH"

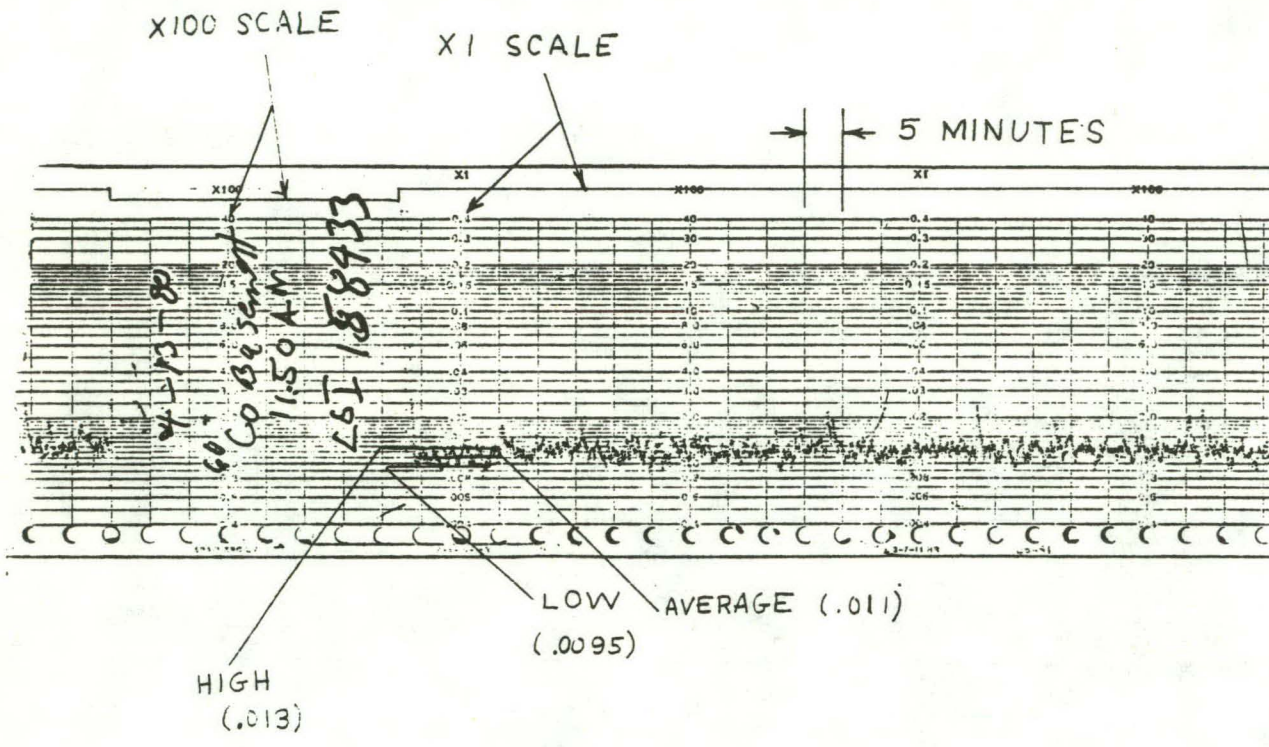

FIG. 3  
 LSI CHART OUTPUT  
 (BACKGROUND)

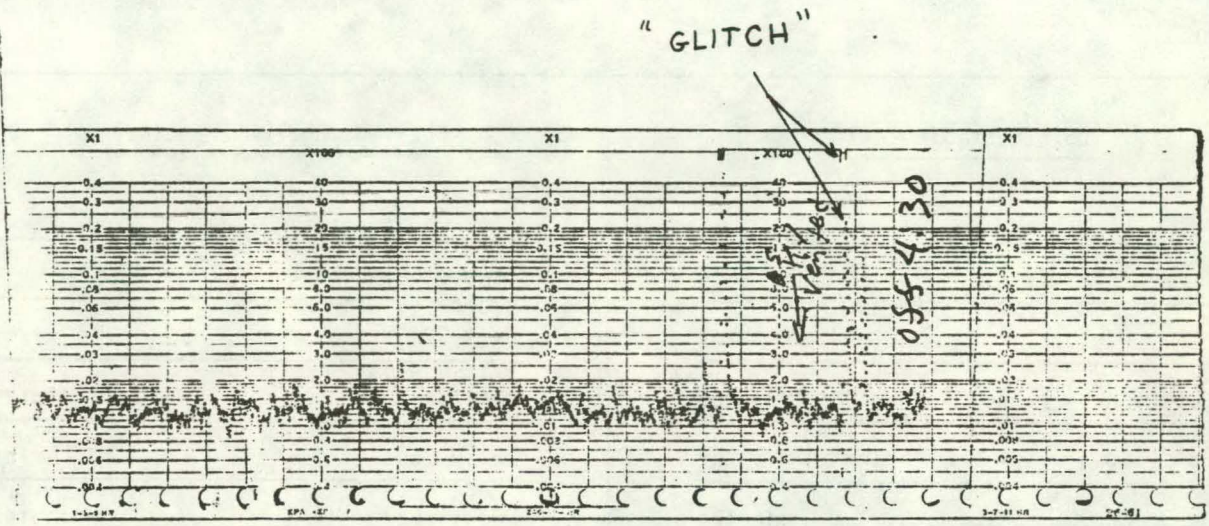

FIG. 4  
LSI "GLITCH"



CITIZEN RADIATION MONITORING PROGRAM

MONITORING REPORT

\_\_\_\_\_  
DATE

LSI (Lear Siegler)

Time On: \_\_\_\_\_

Time of Reading: \_\_\_\_\_

Daily High: \_\_\_\_\_ mr/hr

Duration: \_\_\_\_\_ minutes

Daily Low: \_\_\_\_\_ mr/hr

Duration: \_\_\_\_\_ minutes

Daily Average: \_\_\_\_\_ mr/hr

Eberline/Ludlum (Pancake)

Time On: \_\_\_\_\_

Time of Reading: \_\_\_\_\_

Daily High: \_\_\_\_\_ mr/hr

Duration: \_\_\_\_\_ minutes

Daily Low: \_\_\_\_\_ mr/hr

Duration: \_\_\_\_\_ minutes

Daily Average: \_\_\_\_\_ mr/hr

Comments: \_\_\_\_\_  
\_\_\_\_\_  
\_\_\_\_\_  
\_\_\_\_\_  
\_\_\_\_\_  
\_\_\_\_\_  
\_\_\_\_\_

Signature: Citizen Recording Readings

Checked By: \_\_\_\_\_

OPERATING PROCEDURES - CITIZEN MONITOR

NOTE: The Ludlum Model 177 Alarm Rate Meter, Eberline Model 260 pancake probe, and Rustrak Recorder will be referred to in these procedures as - Ludlum detector. The Lear Siegler Ionization Chamber will be referred to as the - LSI.

To insure accurate and reliable data, these procedures are to be followed without deviation. No changes or deviations are allowed unless approved by a member of the Technical Working Group (TWG).

I. LUDLUM CHECKOUT DURING PERIODIC MONITORING:

1. Unlock the Ludlum instrument box using the key provided.
2. Inspect the Ludlum system for any signs of damage. Check the following:
  - a. Power on light is lighted
  - b. Audible "clicks" from recorder
  - c. Rate meter reading above zero
  - d. Recorder marking chart paper
  - e. Range switch in X1 position
  - f. Response switch in slow
  - g. Depress the Battery test button, meter should deflect to above "BAT OK" marking.
3. If any of the above items appear incorrect proceed to section VIII "In Case of Trouble." Otherwise, go to following section.

II. COLLECTION OF DATA-LUDLUM

1. If the equipment is being started for the first time, go to step 6. Otherwise, proceed to step 2.
2. If the equipment is operating properly, advance the recorder until approximately 4 inches of clear paper are exposed from the machine.
3. Stamp the front of the paper using the rubber stamp provided.
4. Record date, time of stop, and your signature.

5. Tear off the strip chart even with the top of the recorder. Be careful not to cause the paper inside the recorder to be disturbed.
6. Advance the chart paper 4 inches from the recorder.
7. Stamp the front of the paper using the rubber stamp provided.
8. Record date, time of start and your signature.
9. You should now have approximately 32 inches of chart paper with a stamp at either end.
10. Remove the chart paper, a Citizen Radiation Monitoring Program Monitoring Report Form.
11. Close the box and place data aside but do not lock the box at this time.
12. Proceed to the next section.

### III. LSI CHECKOUT DURING PERIODIC MONITORING

1. Open the LSI suitcase.
2. Inspect the LSI for any signs of damage. Check for the following:
  - a. Selector switch is ON
  - b. Audible "clicks" from recorder
  - c. Recorder reading above zero
  - d. Recorder marking paper
3. If any of the above items appear incorrect, proceed to section "In case of Trouble." Otherwise, go to the following section.

### IV. COLLECTION OF DATA - LSI

1. If the equipment is being started for the first time, go to step 6. Otherwise proceed to step 2.
2. If the equipment is operating properly, advance the recorder until approximately 4 inches of clear paper are exposed from the machine.
3. Stamp the front of the paper using the rubber stamp provided.
4. Record date, stop time, and signature.
5. Tear off the strip chart even with the top of the recorder. Be careful not to cause the paper inside the recorder to be disturbed.

6. Advance the chart paper 4 inches from the recorder.
7. Stamp the front of the paper using the rubber stamp provided.
8. Record date, start time, and signature.
9. You should now have approximately 80 inches of chart paper with a stamp at either end.
10. Remove the chart paper and close the suitcase.

V. DATA INTERPRETATION - LUDLUM

1. Pickup the Ludlum data and set the LSI data aside for later review.

NOTE: The Ludlum chart recorder advances at 1 inch per hour. Each time division (1/4 inch) equals 15 min.

NOTE: With the instrument on the XI scale, the full scale reading is 500 counts/min. The smallest scale division is therefore 10 counts/min.

2. Record the "Time On" from the beginning of the chart and the time of reading on the Monitoring report.
3. Scan the tape note the high reading and the low reading. (See Figure 1 attached for definition).
4. Estimate the average reading.
5. If the high reading is greater than the average reading by more than 75 cpm for 5 minutes or more, then estimate and record the duration. Otherwise indicate not applicable "N/A" under duration.
6. Scan the tape for any abnormalities, i.e. "spikes", "glitches", or high readings. Note in the comments section any such indications. (See Figure 2 for samples of these).
7. If any high readings exceed 125 cpm above the average background, notify the TWG at 717-787-3479 immediately and request assistance. Notify your local official.
8. Set the Ludlum data aside. Proceed to the next section.

VI. DATA INTERPRETATION - LSI

NOTE: The LSI Chart Recorder advances at 3 inches per hour. Each time division (1/4 inch) equals 5 min.

NOTE: The instrument is dual range and automatically switches ranges.

NOTE: The range is indicated by the line drawn on the paper as either X1 or X100 (See Figure 3).

NOTE: Full scale on the X1 range is 0.4 mr/hr. Readings must be between 0.004 mr/hr and 0.4 mr/hr.

NOTE: Full scale on the X100 range is 40 mr/hr. Readings must be between 0.4 mr/hr and 40 mr/hr.

1. Record the "Time ON" from the beginning of the chart and the time of reading on the monitoring report.
2. Scan the tape note the high reading and low reading (See Figure 3 for definition).
3. Estimate the average reading.
4. If the high reading is greater than the average reading by .01 mr/hr for 5 min. or more, estimate and record the duration. Otherwise, indicate not applicable "N/A" under duration.
5. Scan the tape for any abnormalities, i.e., spikes, glitches, or high readings. Note in the comments section any such indications. (See Figure 4 for samples of these).
6. If any high readings exceed the average background, by .01 mr/hr notify the TWG at 717-787-3470 immediately and request assistance. Notify your local official.

VII. DATA TRANSMITTAL

1. Sign the Monitoring Report.
2. Remove the community copy of your Monitoring Report.

## VIII. IN CASE OF TROUBLE

NOTE: This section is divided by instrument i.e. Ludlum ratemeter, Rustrak recorder, Pancake probe and LSI. Appropriate actions for various problems are described.

### A. Ludlum Ratemeter

1. If the power on light is not lighted, check to ensure Ludlum Ratemeter power cord is plugged into box receptacle.
2. If cord is plugged in check for proper operation of Rustrak recorder. If recorder is inoperative, power is not available at wall outlet. Request assistance from local official to reactivate power to monitor.
3. If power is available, and ratemeter and recorder are still inoperative, Notify the TWG at 717-787-3479.
4. If ratemeter is not reading above zero and power light is on, examine pancake probe for possible damage.

CAUTION: Probe has a thin window that may be easily punctured.

5. If pancake probe is damaged notify TWG at 717-787-3479.
6. If pancake probe appears intact, then check "SUBTRACT" switch on back of Ludlum ratemeter. "SUBTRACT" switch should be in off position. If switch is "ON" move to "OFF" position and note action in comments section of monitoring report.

7. If the above actions do not identify the problem request assistance from TWG at 717-787-3479.
8. If the range switch is not in the XI position, note the position in the comments section of your monitoring report, switch to XI .
9. If the response switch is not in "slow," note the position in the comments section of your monitoring report, switch to slow.
10. If depressing Battery test button does not cause meter to deflect to above "BAT OK" marking notify TWG at 717-787-3479.

B. BUSTRAK RECORDER

1. If audible "clicks" are not heard, check that recorder power cord is plugged into box receptacle.
2. If cord is plugged in, check Ludlum power on light is lighted on ratemeter.
3. If power on light is not lighted, then check at wall outlet for power. Request assistance from local official to reactivate power to monitor.
4. If power on light is lighted and power is available to recorder but recorder is inoperative, request assistance from TWG.
5. If audible "clicks" are heard but recorder is not marking chart paper, notify TWG at 717-787-3479.



C. LSI

1. If LSI Selector switch is "OFF", switch to "ON", and indicate same on monitoring report.
2. If either audible "clicks" from recorder are not heard or the recorder is not reading above zero, check for power at wall outlet. If power is not available, request assistance from local official.
3. If power is available at wall outlet but recorder is still not operable, notify the TWG at 717-787-3479.
4. If the recorder is not marking the paper, or not advancing notify the TWG at 717-787-3479.

OPERATING PROCEDURE - CIRCUIT RIDER.

1. Proceed to Monitoring Locations designated by TWG and indicated on the circuit rider log sheet.
2. Unlock the Ludlum box.
3. Remove current data consisting of 2 strip charts, one short (32 inches) and one long (80 inches). Remove current monitoring report.
4. If data is not available, note on circuit rider log sheet that data for that day was not available.
5. Place the previous day's data in the Ludlum box.
6. Close the box and lock it.
7. Proceed to next monitoring location.
8. After last location, proceed to Middletown Borough Hall for data drop and pickup.
9. At the Borough Hall, place the current day's data in the appropriate box. Pick up previous day's data.

## OVERALL PROCEDURES

### MONITORING

**EQUIPMENT:** Two types of radiation monitoring equipment will be placed in each participating community at a designated site.

- LSI (Lear Siegler Ionization Chamber)
- Ludlum detector (Ludlum Model 177 Alarm Rate Meter w/Eberline Model 260 pancake probe).

This equipment will record radiation levels 24 hours a day and produce 3" wide output tapes.

### DAILY

**readings:** Citizen monitors (CM's) will make readings at approximately 6:00 p.m. everyday. The citizens have been specifically instructed to operate the equipment and to make measurements. No one else in the community should operate these devices, although citizens may visually observe the readings at any time during the day or evening.

The CM's will sign, date, and indicate the location and time of their reading. If the designated CM's do not make the readings and provide a daily monitoring report, no data will be recorded for their community for that day. CM's are responsible, in conjunction with local officials, to determine a duty roster for the monitoring.

### POSTING

**RESULTS:** After the CM's make their readings, they may post a copy of their daily report at the monitoring site for the public to observe. It is up to the community to determine if and where this data should be made available. The strip chart tapes will be retained

by the Technical Working Group. The tapes will not normally be returned to the community unless they contain any disputed information or otherwise interesting data. The tapes will be available for review, inspection, and copy, at DER, 16th floor, Fulton Bldg.

DATA  
COLLECTION  
&

DISSEMINATION: A circuit rider will pick up data (the strip charts and the CM's daily report) and convey it to the Technical Working Group (TWG) for verification and documentation. The TWG will collect data from all 12 monitoring sites and prepare a summary statement. This summary will be returned to the local communities by the circuit rider on his/her return visit.

In addition, strip chart tapes from each of the local communities will be returned by the circuit rider for posting if any interesting data or disputed information is noted.

UNEXPECTED  
READINGS  
ABOVE

BACKGROUND: The radiation monitoring equipment may register readings above background from time to time. The CM's have been trained to judge whether these readings represent a significant abnormality or not. If an unexpected or abnormal reading does occur, it is imperative that the following procedure be followed:

If the unexpected reading is discovered by the CM, he or she will immediately telephone a member of the TWG at a specially designated phone number. He or she will also immediately notify the local official.

If the unexpected reading is discovered by a local citizen or official other than a CM, that person should contact a CM to verify and interpret the unexpected results. If necessary, after observation of the reading, the CM will contact the TWG and their local official.

Once notified of an unexpected reading, the TWG will gather additional data as needed to determine the cause of the reading. This may require a visit to the site by the TWG representative, verification of the reading by mobile monitoring devices, check of local weather conditions, and a check of possible sources of radiation in the area. This effort by the TWG may require some time during which the TWG would be in contact with the local officials to alert them to the situation and to keep them abreast of explanatory efforts.

**EQUIPMENT  
REPAIR:**

CM's will notify the TWG in the event that the equipment is not operating properly. The equipment will be repaired by the Environmental Protection Agency, who will be notified by the TWG.

OPERATING PROCEDURES - CITIZEN MONITOR

NOTE: The Ludlum Model 177 Alarm Rate Meter, Eberline Model 260 pancake probe, and Rustrak Recorder will be referred to in these procedures as - Ludlum detector. The Lear Siegler Ionization Chamber will be referred to as the - LSI.

To insure accurate and reliable data, these procedures are to be followed without deviation. No changes or deviations are allowed unless approved by a member of the Technical Working Group (TWG).

I. LUDLUM CHECKOUT DURING PERIODIC MONITORING:

1. Unlock the Ludlum instrument box using the key provided.
2. Inspect the Ludlum system for any signs of damage. Check the following:
  - a. Power on light is lighted
  - b. Audible "clicks" from recorder
  - c. Rate meter reading above zero
  - d. Recorder marking chart paper
  - e. Range switch in X1 position
  - f. Response switch in slow
  - g. Depress the Battery test button, meter should deflect to above "BAT OK" marking.
  - h. Check for cable chafing or other problems
  - i. Check for "Renew Tape" on chart paper
3. If any of the above items appear incorrect proceed to section VIII "In Case of Trouble." Otherwise, go to following section.

II. COLLECTION OF DATA-LUDLUM

1. If the equipment is being started for the first time, go to step 6. Otherwise, proceed to step 2.
2. If the equipment is operating properly, advance the recorder until approximately 4 inches of clear paper are exposed from the machine.

3. Stamp the front of the paper using the rubber stamp provided.
4. Record date, time of stop, and your signature.
5. Tear off the strip chart even with the top of the recorder. Be careful not to cause the paper inside the recorder to be disturbed.
6. Advance the chart paper 4 inches from the recorder.
7. Stamp the front of the paper using the rubber stamp provided.
8. Record date, time of start and your signature.
9. You should now have approximately 32 inches of chart paper with a stamp at either end.
10. Remove the chart paper, a Citizen Radiation Monitoring Program Monitoring Report Form.
11. Close the box and place data aside but do not lock the box at this time.
12. Proceed to the next section.

### III. LSI CHECKOUT DURING PERIODIC MONITORING

1. Open the LSI suitcase.
2. Inspect the LSI for any signs of damage. Check for the following:
  - a. Selector switch is ON
  - b. Audible "clicks" from recorder
  - c. Recorder reading above zero
  - d. Recorder marking paper
  - e. Check for renew tape on chart paper
3. If any of the above items appear incorrect, proceed to section "In case of Trouble." Otherwise, go to the following section.

### IV. COLLECTION OF DATA - LSI

1. If the equipment is being started for the first time, go to step 6. Otherwise proceed to step 2.
2. If the equipment is operating properly, advance the recorder until approximately 4 inches of clear paper are exposed from the machine.
3. Stamp the front of the paper using the rubber stamp provided.

4. Record date, stop time, and signature.
5. Tear off the strip chart even with the top of the recorder. Be careful not to cause the paper inside the recorder to be disturbed.
6. Advance the chart paper 4 inches from the recorder.
7. Stamp the front of the paper using the rubber stamp provided.
8. Record date, start time, and signature.
9. You should now have approximately 80 inches of chart paper with a stamp at either end.
10. Remove the chart paper and close the suitcase.

#### V. DATA INTERPRETATION - LUDLUM

1. Pickup the Ludlum data and set the LSI data aside for later review.

NOTE: The Ludlum chart recorder advances at 1 inch per hour.  
Each time division (1/4 inch) equals 15 min.

NOTE: With the instrument on the XI scale, the full scale reading is 500 counts/min. The smallest division is therefore 10 counts/min.

2. Record the "Time On" from the beginning of the chart and the time of the reading on the Monitoring report.
3. Scan the tape note the high reading and the low reading. (See Figure 1 attached for definition).
4. Estimate the average reading.
5. If the high reading is greater than the average reading by more than 75 cpm for 5 minutes or more, then estimate and record the duration. Otherwise indicate not applicable "N/A" under duration.
6. Scan the tape for any abnormalities, i.e. "spikes", "glitches", or high readings. Note in the comments section any such indications. (See Figure 2 for samples of these).
7. If any high readings exceed 125 cpm above the average background, notify the TWG at 717-787-3479 immediately and request assistance. Notify your local official.
8. Set the Ludlum data aside. Proceed to the next section.



## VI. DATA INTERPRETATION - LSI

NOTE: The LSI Chart Recorder advances at 3 inches per hour. Each time division (1/4 inch) equals 5 min.

NOTE: The instrument is dual range and automatically switches ranges.

NOTE: The range is indicated by the line drawn on the paper as either X1 or X100 (See Figure 3).

NOTE: Full scale on the X1 range is 0.4 mr/hr. Readings must be between 0.004 mr/hr and 0.4 mr/hr.

NOTE: Full scale on the X100 range is 40 mr/hr. Readings must be between 0.4 mr/hr and 40 mr/hr

1. Record the "Time ON" from the beginning of the chart and the time of reading on the monitoring report.
2. Scan the tape note the high reading and low reading (See Figure 3 for definition).
3. Estimate the average reading.
4. If the high reading is greater than the average reading by .01 mr/hr for 5 min. or more, estimate and record the duration. Otherwise, indicate not applicable "N/A" under duration.
5. Scan the tape for any abnormalities, i.e., spikes, glitches, or high readings. Note in the comments section any such indications. (See Figure 4 for samples of these).
6. If any high readings exceed the average background, by .015 mr/hr for 5 min. or more, notify the TWG at 717-787-3479 immediately and request assistance. Notify your local official.

## VII. DATA TRANSMITTAL

1. Sign the Monitoring Report.
2. Remove the community copy of your Monitoring Report.

3. Open the LSI box. Place the Ludlum Data, LSI Data, and the original monitoring report for that day in the box and remove the previous day's data and report.
4. Close the LSI box.
5. Take the previous day's data, the TWG summary sheet, and the community copy of today's data to the place designated by your local official.

NOTE: Original tapes will be retained by DER. They are available for review and copy at any time.

6. Replace stamp and stamp pad in the Ludlum box. Lock the Ludlum box.
7. Check that Ludlum is operating properly.

#### VIII. IN CASE OF TROUBLE

NOTE: This section is divided by instrument i.e. Ludlum ratemeter, Rustrak recorder, Pancake probe and LSI. Appropriate actions for various problems are described.

##### A. Ludlum Ratemeter

1. If the power on light is not lighted, check to ensure Ludlum Ratemeter power cord is plugged into box receptacle.
2. If cord is plugged in check for proper operation of Rustrak recorder. If recorder is inoperative, power is not available at wall outlet. Request assistance from local official to reactivate power to monitor.
3. If power is available, and ratemeter and recorder are still inoperative, Notify the TWG at 717-787-3479.
4. If ratemeter is not reading above zero and power light is on, examine pancake probe for possible damage.

CAUTION: Probe has a thin window that may be easily punctured.

5. If pancake probe is damaged notify TWG at 717-787-3479.
6. If pancake probe appears intact, then check "SUBTRACT" switch on back of Ludlum ratemeter. "SUBTRACT" switch should be in off position. If switch is "ON" move to "OFF" position and note action in comments section of monitoring report.

7. If the above actions do not identify the problem request assistance from TWG at 717-787-3479.
8. If the range switch is not in the XI position, note the position in the comments section of your monitoring report, switch to XI.
9. If the response switch is not in "slow," note the position in the comments section of your monitoring report, switch to slow.
10. If depressing Battery test button does not cause meter to deflect to above "BAT OK" marking notify TWG at 717-787-3479.

B. BUSTRAK RECORDER

1. If audible "clicks" are not heard, check that recorder power cord is plugged into box receptacle.
2. If cord is plugged in, check Ludlum power on light is lighted on ratemeter.
3. If power on light is not lighted, then check at wall outlet for power. Request assistance from local official to reactivate power to monitor.
4. If power on light is lighted and power is available to recorder but recorder is inoperative, request assistance from TWG.
5. If audible "clicks" are heard but recorder is not marking chart paper, notify TWG at 717-787-3479.
6. If "renew tape" appears, notify TWG at 717-787-3479.

C. LSI

1. If LSI Selector switch is "OFF", switch to "ON", and indicate same on monitoring report.
2. If either audible "clicks" from recorder are not heard or the recorder is not reading above zero, check for power at wall outlet. If power is not available, request assistance from local official.
3. If power is available at wall outlet but recorder is still not operable, notify the TWG at 717-787-3479.
4. If the recorder is not marking the paper, or not advancing, notify the TWG at 717-787-3479.
5. If "renew tape" appears, notify the TWG at 717-787-3479.

OPERATING PROCEDURE - CIRCUIT RIDER.

1. Proceed to Monitoring Locations designated by TWG and indicated on the circuit rider log sheet.
2. Open the LSI box.
3. Remove current data consisting of 2 strip charts, one short (32 inches) and one long (80 inches). Remove current monitoring report.
4. If data is not available, note on circuit rider log sheet that data for that day was not available.
5. Place the previous day's data in the LSI box.
6. Close the box.
7. Proceed to next monitoring location.
8. After last location, proceed to DER drop, 16th floor, Fulton Bldg., for data drop and pickup.
9. At DER, place the current day's data in the appropriate box. Pick up previous day's data.

## Concept of Operations

**Objective:** The intent of the Community Monitoring Program is the providing to municipal government the means to make independent observations of the radiation environment near Three Mile Island.

The program is not intended to provide an early warning in case of radiation accidents. The Program is, in essence, an independent routine surveillance program.

**Method:** Raw data is collected from the instruments and analyzed by the individual Monitor. The finished or reduced data is recorded by the Monitor on a form provided. The finished data form for the period of observation, (a copy of which is retained by the Monitor) along with the corresponding strip charts is sent to the Technical Working Group for checking and compilation with similar data from the other participating communities.

Copies of the compiled data are furnished to the following organizations on the day the data is compiled:

- Capitol News Room
- County Government
- Governor's Hot Line
- U. S. Nuclear Regulatory Commission
- Metropolitan Edison Co.

A copy of the compiled data is distributed to the Monitors when the next batch of raw and finished data is picked up. Data collected by the Monitor and the compiled data returned to the Monitor may be used and displayed in any manner the municipality sees fit.

## Monitor

**Definition:** A Monitor is one of several people in a municipality who has been nominated by local elected officials and who has successfully completed the Community Monitoring Training Program.

**Job:** The Monitor will, on a routine basis, collect and reduce data recorded from instruments provided. The Monitor shall use specific procedures learned in the course of training and furnished in writing with the instruments.

### Interactions:

**Monitor/Community:** Data gathered by the Monitor shall be considered public information. The data may be presented to the community in any manner agreed upon by the Monitors and their respective local elected officials.

**Monitor/Circuit Rider:** Circuit Riders will, on a routine basis, collect from the Monitors one copy of the finished data and the raw data from both instruments.

Circuit Rider will, on a routine basis, (next round) return to each Monitor Station a copy of the compiled data from the previous round.

**Monitor/Technical Working Group:** Monitors will direct technical and operational questions and equipment related problems through a special Commonwealth (DER) telephone number. The Technical Working Group will direct questions on raw and finished data back to the Monitor, who gathered the data, by telephone.

**Monitor/Med Ed:** None

**Monitor/USNRC:** None

**Monitor/Media:** At the Monitor's discretion.



## Technical Working Group

Definition: The Technical Working Group consists of professional radiation protection specialists representing the Commonwealth (DER), Pennsylvania State University, U.S. Environmental Protection Agency and U.S. Department of Energy.

Job: The Technical Working Group (TWG) will check raw data against the reduced (finished) data submitted by the Monitors. TWG shall compile the finished data, on a routine basis, and distribute them to:

- a. News Media (except weekends and holidays through the Capitol News Room)
- b. County Government (except weekends and holidays through PEMA teletype)
- c. Governor's Hot Line (except weekends and holidays; hand carried)
- d. Licensee (as gathered; by telefax)
- e. USNRC - Middletown (as gathered; by telefax)
- f. TWG Agencies (through respective TWG representatives)
- g. Monitors (by next Circuit Rider round)

TWG will provide advice to the Monitors, on their request, and will provide for correction of instrument problems as necessary after notice from the Monitor. TWG will also collect and disseminate data from other agencies to the involved communities.

### Interactions:

TWG/Monitors: TWG will review the raw data (strip charts) and the finished data from the Monitor. TWG will compile the finished data and distribute it immediately to the Capitol News Room, the Counties, Governor's Hot Line, USNRC, Met Ed., and the TWG Agencies.

TWG/Circuit Rider: TWG shall receive each Monitor's raw and finished data from the Circuit Rider. TWG will provide the Circuit Rider with copies of the compiled data for distribution to the Monitors on the next run.

TWG/Media/Counties/Governor's Hot Line, USNRC/Met Ed:  
TWG will provide these organizations with compiled data on the day  
it is compiled. TWG will answer inquiries as presented.

TWG/Communities: As appropriate

TWG/EPA: Assistance from EPA may be requested to identify and  
resolve any significant above background radiation levels. In this  
capacity, EPA will assist TWG by taking such surveys/samples as  
deemed appropriate, e.g. swipes, air samples, water, etc.

TWG/NRC, EPA, Met Ed., etc.: Data provided by these agencies  
to TWG will be distributed at the TWG discretion to the involved  
communities.

## Circuit Rider

**Definition:** The Circuit Rider is a State or Federal Government employee who routinely gathers the raw and finished data from the Monitors.

**Job:** Circuit Rider routinely collects raw and finished data from the Monitor and delivers it to the Technical Working Group. He collects copies of the compiled data for return to the Monitor on the next run.

### **Interactions:**

Circuit Rider/Monitor: See Job

Circuit Rider/TWG: See Job

Circuit Rider/Community: None

Circuit Rider/Media: Circuit Rider's discretion.

Circuit Rider/Counties/USNRC/Met Ed/Governor's Hot Line: None

Appendix D

Reporting Form and

Monitoring Results

CITIZEN RADIATION MONITORING PROGRAM

MONITORING REPORT

DATE

<u>LSI (Lear Siegler)</u>	<u>Eberline/Ludlum (Pancake)</u>
Time On: _____	Time On: _____
Time of Reading: _____	Time of Reading: _____
Daily High: _____ mr/hr	Daily High: _____ mr/hr
Duration: _____ minutes	Duration: _____ minutes
Daily Low: _____ mr/hr	Daily Low: _____ mr/hr
Duration: _____ minutes	Duration: _____ minutes
Daily Average: _____ mr/hr	Daily Average: _____ mr/hr

Comments: \_\_\_\_\_

\_\_\_\_\_

\_\_\_\_\_

\_\_\_\_\_

\_\_\_\_\_

\_\_\_\_\_

\_\_\_\_\_

Signature: Citizen Recording Readings

Checked By: \_\_\_\_\_

FIGURE 3

COMMONWEALTH OF PENNSYLVANIA  
DEPARTMENT OF ENVIRONMENTAL RESOURCES  
HARRISBURG, PENNSYLVANIA

PRESS RELEASE  
Newsroom  
Contact: Amy Keichner  
Telephone 717-787-2163  
May 27, 1980

FOR IMMEDIATE RELEASE

HARRISBURG — Following are the results of the Community Monitoring program for May 23, 24, 25 and 26, 1980.

All readings were within the range of natural background levels for the sampling days May 23-26, 1980. A more detailed summary of the results is attached.

GAMMA RATE RECORDERS (LSI)

Gamma rate recorders (LSI) are used to measure gamma radiation levels at the monitoring site. The recorders are sensitive enough to measure radiation from naturally-occurring radiation sources. The following table summarizes the measurements made for each monitoring location. The data were reported on May 23, 1980. The results are shown in millirem/hour (mrem/hr).

<u>Location</u>	<u>Average (mrem/hr)</u>	<u>Comment</u>
Fairview	0.015	Normal Background
Newberrytown	0.008	Normal Background
Goldsboro	0.013	Normal Background
York Haven	Data to EPA	
East Manchester	No Instrument	
Lower Swatara	0.007	Normal Background
Middletown	0.012	Normal Background
Royalton	0.015	Normal Background
Londonderry	Data to EPA	
Conoy	0.013	Normal Background
West Donegal	0.009	Normal Background
Elizabethtown	No Instrument	

BETA RATE RECORDERS (LUDLUM)

Beta rate recorders (Ludlum) are used to measure beta and gamma radiation levels at the monitoring site. The recorders are sensitive enough to measure radiation from naturally-occurring radiation sources.

Each station recorded beta levels less than .005 m/rem an hour.

Distribution:

EPA	DOE
NRC	Met-Ed
PEMA	GAC
Newsroom	

### GAMMA RATE RECORDERS (LSI)

Gamma rate recorders (LSI) are used to measure gamma radiation levels at the monitoring site. The recorders are sensitive enough to measure radiation from naturally-occurring radiation sources. The following table summarizes the measurements made for each monitoring location. The data were reported on May 24, 1980. The results are shown in millirem/hour (mrem/hr).

<u>Location</u>	<u>Average (mrem/hr)</u>	<u>Comment</u>
Fairview	Instrument Failure	
Newberrytown	0.008	Normal Background
Goldsboro	0.013	Normal Background
York Haven	Data to EPA	
East Manchester	No Instrument	
Lower Swatara	0.007	Normal Background
Middletown	0.011	Normal Background
Royalton	0.016	Normal Background
Londonderry	Data To EPA	
Conoy	0.014	Normal Background
West Donegal	Instrument Failure	
Elizabethtown	No Instrument	

### BETA RATE RECORDERS (LUDLUM)

Beta rate recorders (Ludlum) are used to measure beta and gamma radiation levels at the monitoring site. The recorders are sensitive enough to measure radiation from naturally-occurring radiation sources.

Each station recorded beta levels less than .005 m/rem an hour.

**Distribution:**

EPA	DOE
NRC	Met-Ed
PEMA	GAC
Newsroom	



GAMMA RATE RECORDERS (LSI)

Gamma rate recorders (LSI) are used to measure gamma radiation levels at the monitoring site. The recorders are sensitive enough to measure radiation from naturally-occurring radiation sources. The following table summarizes the measurements made for each monitoring location. The data were reported on May 25, 1980. The results are shown in millirem/hour (mrem/hr).

<u>Location</u>	<u>Average (mrem/hr)</u>	<u>Comment</u>
Fairview	Instrument Failure	
Newberrytown	0.008	Normal Background
Goldsboro	0.013	Normal Background
York Haven	Data to EPA	
East Manchester	No Instrument	
Lower Swatara	0.007	Normal Background
Middletown	0.009	Normal Background
Royalton	0.016	Normal Background
Londonderry	Data to EPA	
Conoy	0.013	Normal Background
West Donegal	Instrument Failure	
Elizabethtown	No Instrument	

BETA RATE RECORDERS (LUDLUM)

Beta rate recorders (Ludlum) are used to measure beta and gamma radiation levels at the monitoring site. The recorders are sensitive enough to measure radiation from naturally-occurring radiation sources.

Each station recorded beta levels less than .005 m/rem an hour.

Distribution:

EPA	DOE
NRC	Met-Ed
PEMA	GAC
Newsroom	

GAMMA RATE RECORDERS (LSI)

Gamma rate recorders (LSI) are used to measure gamma radiation levels at the monitoring site. The recorders are sensitive enough to measure radiation from naturally-occurring radiation sources. The following table summarizes the measurements made for each monitoring location. The data were reported on May 26, 1980. The results are shown in millirem/hour (mrem/hr).

<u>Location</u>	<u>Average (mrem/hr)</u>	<u>Comment</u>
Fairview	Instrument Failure	
Newberrytown	0.008	Normal Background
Goldsboro	0.014	Normal Background
York Haven	Data to EPA	
East Manchester	No Instrument	
Lower Swatara	0.007	Normal Background
Middletown	0.010	Normal Background
Royalton	0.015	Normal Background
Londonderry	Data to EPA	
Conoy	No Data Available	
West Donegal	0.009	Normal Background
Elizabethtown	No Instrument	

BETA RATE RECORDERS (LUDLUM)

Beta rate recorders (Ludlum) are used to measure beta and gamma radiation levels at the monitoring site. The recorders are sensitive enough to measure radiation from naturally-occurring radiation sources.

Each station recorded beta levels less than .005 m/rem an hour.

Distribution:

EPA	DOE
NRC	Met-Ed
PEMA	GAC
Newsroom	

COMMUNITY MONITORING PROGRAM

	TIME STOP	LSI (mgm/hr)			VOLUME (GPM)		
		HIGH	LOW	Avg	HIGH	LOW	Avg
FERRIS W	1840	0.019	0.010	0.015	45	5	25
NEWBERRY	1800	0.007	0.004	0.0075 0.008	INSTRUMENT FAILURE		
GOLDSBERG	1855	0.015	0.012	0.013	40	10	35
YORK HAVEN	1800	DATA TO EPA			75	10	35
E. MANCHESTER	1840	NO INSTRUMENT			50	10	30
LOWER SWATARA	1920	0.009	0.005	0.007	45	5	25
MIDDLETOWN	1800	0.020	0.008	0.012	70	10	45
ROYALTON	1800	0.020	0.013	0.015	60	45	55
LONDON DERRY	1700	DATA TO EPA			70	15	40
CONCY	2030	0.020	0.010	0.013	INSTRUMENT FAILURE		
W. DONEGAL	2100	0.012	0.008	0.009	50	20	35
ELIZABETH TOWN	1700	NO INSTRUMENT			50	20	35

304

DAY ENDING: MAY 23, 1980

E. Snyder  
5-7-80

# COMMUNITY MONITORING PROGRAM

	TIME STOP	LST (micro/hr)			LUDM (cpm)		
		MAX	LOW	AVG	MAX	LOW	AVG
FAIRVIEW	1700	INSTRUMENT FAILURE			45	5	25
NEWBERRY	1810	0.017	0.006	0.008	60	20	40
GOLDSBORO	1950	0.015	0.012	0.013	INSTRUMENT FAILURE		
YORK HAVEN	1810	DATA TO EPA			80	10	25
E. MANCHESTER (S-24, S-25, S-26 data combined)	1720	NO INSTRUMENT			50	15	30
LOWER SWATARA (S-24, S-25 DATA COMBINED)	1800	0.009	0.005	0.007	45	5	25
MIDDLETOWN	1800	0.015	0.007	0.011	90	10	40
ROYALTON	1800	0.019	0.013	0.016	65	40	50
LONDONDERRY	1700	DATA TO EPA			85	10	40
CONROY	1800	0.020	0.010	0.014	INSTRUMENT FAILURE		
W. DONEGAL	1915	INSTRUMENT FAILURE			50	20	35
ELIZABETHTOWN	1300	NO INSTRUMENT			50	20	35

305

DAY ENDING: MAY 24, 1980

BE Snyder  
5/27/80

# COMMUNITY MONITORING PROGRAM

	TIME STOP	LSI (microg/hr)			PLG	LUDLOW (cpm)	
		HIGH	LOW	AVG		LOW	AVG
FAIRVIEW	700	INSTRUMENT FAILURE			45	5	25
NEWBERRY	1745	0.010	0.007	0.008	55	30	45
GOLDSBORO	2000	0.015	0.012	0.013	40	10	25
YORK HAVEN	1800	DATA TO EPA			75	5	35
E. MANCHESTER (5-24, 5-25, 5-26 DATA COMBINED)	1730	NO INSTRUMENT			50	15	30
LOWER SWATTARA (5-24, 5-25 DATA COMBINED)	1800	0.007	0.005	0.007	45	5	25
MIDDLETOWN	1500	0.020	0.006	0.009	60	5	30
ROYALTON	1800	0.020	0.013	0.016	65	40	50
LONDONDERRY (5-25, 5-26 DATA COMBINED)	1900	DATA TO EPA			60	35	40
CONROY	1830	0.020	0.010	0.013	INSTRUMENT FAILURE		
W. DOMEHAL	2015	INSTRUMENT FAILURE			70	20	25
ELIZABETHTOWN		NO INSTRUMENT			INSTRUMENT FAILURE		
DAY ENDING:	MAY 25, 1980				B. E. Saylor		

306

COMMUNITY MONITORING PROGRAM

	TIME	LSE (micro/ltr)			LTD (micro)		
		HIGH	LOW	AVG	HIGH	LOW	AVG
FARRVIEW	1600	INSTRUMENT FAILURE			50	5	25
NEWBERRY	1730	0.010	0.0045	0.008	55	25	40
GOODSBORO	1810	0.015	0.013	0.014	40	10	25
YORK HAVEN	1745	DATA TO EPA			80	10	40
E. MANCHESTER (5-24, 5-25, 5-26 DATA COMBINED)	1720	NO INSTRUMENT			50	15	30
LOWER SWITZER	2200	0.009	0.005	0.007	45	15	25
MIDDLETOWN	1800	0.015	0.007	0.0095 0.010	70	5	30
ROYALTON	1800	0.017	0.013	0.015	65	40	55
LONDONERRY (5-25, 5-26 DATA COMBINED)	1900	DATA TO EPA			60	25	40
CONROY	NO	DATA AVAILABLE			NO DATA AVAILABLE		
W. DONEGAL	1940	0.011	0.007	0.007	50	20	35
ELIZABETH TOWN		NO INSTRUMENT			INSTRUMENT FAILURE		
DAY ENDING: MAY 26, 1980					GE. Syler 5/27/80		

307

COMMONWEALTH OF PENNSYLVANIA  
DEPARTMENT OF ENVIRONMENTAL RESOURCES  
HARRISBURG, PENNSYLVANIA

PRESS RELEASE  
Newsroom  
Contact: Amy Kelchner  
Telephone 717-787-2163  
May 28, 1980

FOR IMMEDIATE RELEASE

HARRISBURG -- Following are the results of the Community Monitoring program  
for May 27, 1980 :

All readings were within the range of natural background  
levels for the sampling day ending May 27, 1980. A more  
detailed summary of the results is attached.

GAMMA RATE RECORDERS (LSI)

Gamma rate recorders (LSI) are used to measure gamma radiation levels at the monitoring site. The recorders are sensitive enough to measure radiation from naturally-occurring radiation sources. The following table summarizes the measurements made for each monitoring location. The data were reported on May 27, 1980. The results are shown in millirem/hour (mrem/hr).

<u>Location</u>	<u>Average (mrem/hr)</u>	<u>Comment</u>
Fairview	Instrument Failure	
Newberrytown	0.008	Normal Background
Goldsboro	0.013	Normal Background
York Haven	Data to EPA	
East Manchester	No Instrument	
Lower Swatara	0.006	Normal Background
Middletown	0.011	Normal Background
Royalton	0.015	Normal Background
Londonderry	Data to EPA	
Conoy	0.014	Normal Background
West Donegal	0.008	Normal Background
Elizabethtown	No Instrument	

BETA RATE RECORDERS (LUDLUM)

Beta rate recorders (Ludlum) are used to measure beta and gamma radiation levels at the monitoring site. The recorders are sensitive enough to measure radiation from naturally-occurring radiation sources.

Each station recorded beta levels less than .005 m/rem an hour.

Distribution:

EPA	DOE
NRC	Met-Ed
PEMA	GAC
Newsroom	



COMMONWEALTH OF PENNSYLVANIA  
DEPARTMENT OF ENVIRONMENTAL RESOURCES  
HARRISBURG, PENNSYLVANIA

PRESS RELEASE  
Newsroom  
Contact: Amy Kelchner  
Telephone 717-787-2163  
May 29, 1980

FOR IMMEDIATE RELEASE

HARRISBURG -- Following are the results of the Community Monitoring program  
for May 28, 1980 :

All readings were within the range of natural background  
levels for the sampling day ending May 28, 1980. A more  
detailed summary of the results is attached.

### GAMMA RATE RECORDERS (LSI)

Gamma rate recorders (LSI) are used to measure gamma radiation levels at the monitoring site. The recorders are sensitive enough to measure radiation from naturally-occurring radiation sources. The following table summarizes the measurements made for each monitoring location. The data were reported on June 25, 1980. The results are shown in millirem/hour (mrem/hr).

<u>Location</u>	<u>Average (mrem/hr)</u>	<u>Comment</u>
Fairview	0.010	Normal Background
Newberrytown	0.008	Normal Background
Goldsboro	0.013	Normal Background
York Haven	Data to EPA	
East Manchester	Instrument Failure	
Lower Swatara	0.007	Normal Background
Middletown	0.010	Normal Background
Royalton	0.016	Normal Background
Londonderry	Data to EPA	
Conoy	No Data Available	
West Donegal	0.015	Normal Background
Elizabethtown	0.008	Normal Background

### BETA RATE RECORDERS (LUDLUM)

Beta rate recorders (Ludlum) are used to measure beta and gamma radiation levels at the monitoring site. The recorders are sensitive enough to measure radiation from naturally-occurring radiation sources.

Each station recorded beta levels less than .005 m/rem an hour.

**Distribution:**

EPA	DOE
NRC	Met-Ed
PEMA	GAC
Newsroom	

### GAMMA RATE RECORDERS (LSI)

Gamma rate recorders (LSI) are used to measure gamma radiation levels at the monitoring site. The recorders are sensitive enough to measure radiation from naturally-occurring radiation sources. The following table summarizes the measurements made for each monitoring location. The data were reported on June 24, 1980. The results are shown in millirem/hour (mrem/hr).

<u>Location</u>	<u>Average (mrem/hr)</u>	<u>Comment</u>
Fairview	0.009	Normal Background
Newberrytown	0.008	Normal Background
Goldsboro	0.014	Normal Background
York Haven	Data to EPA	
East Manchester	No Data Available	
Lower Swatara	No Data Available	
Middletown	0.009	Normal Background
Royalton	0.016	Normal Background
Londonderry	Data to EPA	
Conoy	0.013	Normal Background
West Donegal	0.015	Normal Background
Elizabethtown	0.008	Normal Background

### BETA RATE RECORDERS (LUDLUM)

Beta rate recorders (Ludlum) are used to measure beta and gamma radiation levels at the monitoring site. The recorders are sensitive enough to measure radiation from naturally-occurring radiation sources.

Each station recorded beta levels less than .005 m/rem an hour.

**Distribution:**

EPA	DOE
NRC	Met-Ed
PEMA	GAC
Newsroom	

### GAMMA RATE RECORDERS (LSI)

Gamma rate recorders (LSI) are used to measure gamma radiation levels at the monitoring site. The recorders are sensitive enough to measure radiation from naturally-occurring radiation sources. The following table summarizes the measurements made for each monitoring location. The data were reported on June 23, 1980. The results are shown in millirem/hour (mrem/hr).

<u>Location</u>	<u>Average (mrem/hr)</u>	<u>Comment</u>
Fairview	0.009	Normal Background
Newberrytown	0.008	Normal Background
Goldsboro	0.013	Normal Background
York Haven	Data to EPA	
East Manchester	0.013	Normal Background
Lower Swatara	No Data Available	
Middletown	0.010	Normal Background
Royalton	0.016	Normal Background
Londonderry	Data to EPA	
Conoy	0.012	Normal Background
West Donegal	0.015	Normal Background
Elizabethtown	0.008	Normal Background

### BETA RATE RECORDERS (LUDLUM)

Beta rate recorders (Ludlum) are used to measure beta and gamma radiation levels at the monitoring site. The recorders are sensitive enough to measure radiation from naturally-occurring radiation sources.

Each station recorded beta levels less than .005 m/rem an hour.

**Distribution:**

EPA	DOE
NRC	Met-Ed
PEMA	GAC
Newsroom	

COMMONWEALTH OF PENNSYLVANIA  
DEPARTMENT OF ENVIRONMENTAL RESOURCES  
HARRISBURG, PENNSYLVANIA

PRESS RELEASE  
Newsroom  
Contact: Amy Kelchner  
Telephone: 717-/87-2163  
July 3, 1980

FOR IMMEDIATE RELEASE

HARRISBURG -- Following are the results of the Community Monitoring Program  
for July 2, 1980.

All readings for 8 stations were within the range of  
natural background levels for the sampling day ending  
July 2, 1980.

Four stations, Middletown, Royaltown, Londonderry and  
Conoy reported beta levels (Kr-85) above the normal  
background. The levels recorded were consistent  
with wind direction and with readings taken by EPA  
and other agencies during the same time period.

A more detailed summary of the results is attached.

### GAMMA RATE RECORDERS (LSI)

Gamma rate recorders (LSI) are used to measure gamma radiation levels at the monitoring site. The recorders are sensitive enough to measure radiation from naturally-occurring radiation sources. The following table summarizes the measurements made for each monitoring location. The data were reported on July 2, 1980. The results are shown in millirem/hour (mrem/hr).

<u>Location</u>	<u>Average (mrem/hr)</u>	<u>Comment</u>
Fairview	0.009.	Normal Background
Newberrytown	No report from Community Monitor	
Goldsboro	0.014	Normal Background
York Haven	Data to EPA	
East Manchester	0.010	Normal Background
Lower Swatara	No Report from Community Monitor	
Middletown	0.009	Normal Background
Royalton	0.017	Normal Background
Londonderry	Data to EPA	
Conoy	0.014	Normal Background
West Donegal	0.015	Normal Background
Elizabethtown	0.008	Normal Background

### BETA RATE RECORDERS (LUDLUM)

Beta rate recorders (Ludlum) are used to measure beta and gamma radiation levels at the monitoring site. The recorders are sensitive enough to measure radiation from naturally-occurring radiation sources.

8 stations recorded beta levels less than .005 m/rem an hour.

Following are beta skin dose levels for the 4 additional stations:

Middletown	-	.014 millirem
Royalton	-	.019 millirem
Londonderry	-	.024 millirem
Conoy	-	.004 millirem

**Distribution:**

EPA	DOE
NRC	Met-Ed
PEMA	GAC
Newsroom	

COMMONWEALTH OF PENNSYLVANIA  
DEPARTMENT OF ENVIRONMENTAL RESOURCES  
HARRISBURG, PENNSYLVANIA

PRESS RELEASE  
Newsroom  
Contact: Amy Kelchner  
Telephone 717-787-2163  
July 7, 1980

FOR IMMEDIATE RELEASE

HARRISBURG — Following are the results of the Community Monitoring Program for July 3, 4, 5 and 6, 1980.

On July 3, Newberry, York Haven and Londonderry reported beta levels (Kr-85) above the normal background.

On July 4, Goldsboro, Royalton, Londonderry, Conoy and West Donegal reported beta levels (Kr-85) above the normal background.

On July 5, Middletown, Royalton, Londonderry and Lower Swatara reported beta levels (Kr-85) above the normal background.

On July 6, York Haven, Londonderry and Conoy reported beta levels (Kr-85) above the normal background.

The stations not listed reported readings within the range of natural background levels.

All the readings above normal background were at levels consistent with wind direction and with readings taken by EPA and other agencies during the same period. A more detailed summary of the results is attached.

GAMMA RATE RECORDERS (LSI)

Gamma rate recorders (LSI) are used to measure gamma radiation levels at the monitoring site. The recorders are sensitive enough to measure radiation from naturally-occurring radiation sources. The following table summarizes the measurements made for each monitoring location. The data were reported on July 3, 1980. The results are shown in millirem/hour (mrem/hr).

<u>Location</u>	<u>Average (mrem/hr)</u>	<u>Comment</u>
Fairview	0.010	Normal Background
Newberrytown	0.008	Normal Background
Goldsboro	No report from Community Monitor	
York Haven	Data to EPA	
East Manchester	0.010	Normal Background
Lower Swatara	0.008	Normal Background
Middletown	0.010	Normal Background
Royalton	0.017	Normal Background
Londonderry	Data to EPA	
Conoy	0.012	Normal Background
West Donegal	0.015	Normal Background
Elizabethtown	0.008	Normal Background

BETA RATE RECORDERS (LUDLUM)

Beta rate recorders (Ludlum) are used to measure beta and gamma radiation levels at the monitoring site. The recorders are sensitive enough to measure radiation from naturally-occurring radiation sources.

9 stations recorded beta levels less than .005 m/rem an hour.

Following are beta skin dose levels for the 3 additional stations. These positive readings are above the .005 normal background reading.

Newberry	-	0.003 millirem
York Haven	-	0.037 millirem
Londonderry	-	0.056 millirem

Distribution:

EPA	DOE
NRC	Met-Ed
PEMA	GAC
Newsroom	PHS



### GAMMA RATE RECORDERS (LSI)

Gamma rate recorders (LSI) are used to measure gamma radiation levels at the monitoring site. The recorders are sensitive enough to measure radiation from naturally-occurring radiation sources. The following table summarizes the measurements made for each monitoring location. The data were reported on July 4, 1980. The results are shown in millirem/hour (mrem/hr).

<u>Location</u>	<u>Average (mrem/hr)</u>	<u>Comment</u>
Fairview	0.009	Normal Background
Newberrytown	0.008	Normal Background
Goldsboro	Instrument Failure	
York Haven	Data to EPA	
East Manchester	0.012	Normal Background
Lower Swatara	0.007	Normal Background
Middletown	0.010	Normal Background
Royalton	0.019	Normal Background
Londonderry	Data to EPA	
Conoy	0.012	Normal Background
West Donegal	0.015	Normal Background
Elizabethtown	0.008	Normal Background

### BETA RATE RECORDERS (LUDLUM)

Beta rate recorders (Ludlum) are used to measure beta and gamma radiation levels at the monitoring site. The recorders are sensitive enough to measure radiation from naturally-occurring radiation sources.

7 stations recorded beta levels less than .005 m/rem an hour.

Following are beta skin dose levels for the 5 additional stations. These positive readings are above the .005 normal background reading.

Goldsboro	-	0.004 millirem
Royalton	-	0.025 millirem
Londonderry	-	0.015 millirem
Conoy	-	0.007 millirem
West Donegal	-	0.011 millirem

**Distribution:**

EPA	DOE
NRC	Met-Ed
PEMA	GAC
Newsroom	PHS

### GAMMA RATE RECORDERS (LSI)

Gamma rate recorders (LSI) are used to measure gamma radiation levels at the monitoring site. The recorders are sensitive enough to measure radiation from naturally-occurring radiation sources. The following table summarizes the measurements made for each monitoring location. The data were reported on July 5, 1980. The results are shown in millirem/hour (mrem/hr).

<u>Location</u>	<u>Average (mrem/hr)</u>	<u>Comment</u>
Fairview	0.009	Normal Background
Newberrytown	0.008	Normal Background
Goldsboro	0.014	Normal Background
York Haven	Data to EPA	
East Manchester	0.015	Normal Background
Lower Swatara	0.008	Normal Background
Middletown	0.010	Normal Background
Royalton	0.017	Normal Background
Londonderry	Data to EPA	
Conoy	0.012	Normal Background
West Donegal	0.015	Normal Background
Elizabethtown	0.009	Normal Background

### BETA RATE RECORDERS (LUDLUM)

Beta rate recorders (Ludlum) are used to measure beta and gamma radiation levels at the monitoring site. The recorders are sensitive enough to measure radiation from naturally-occurring radiation sources.

8 stations recorded beta levels less than .005 m/rem an hour.

Following are beta skin dose levels for the 4 additional stations. These positive readings are above the .005 normal background reading.

Middletown	-	0.011 millirem
Royalton	-	0.022 millirem
Londonderry	-	0.004 millirem
Lower Swatara	-	0.006 millirem

**Distribution:**

EPA	DOE
NRC	Met-Ed
PEMA	GAC
Newsroom	PHS

GAMMA RATE RECORDERS (LSI)

Gamma rate recorders (LSI) are used to measure gamma radiation levels at the monitoring site. The recorders are sensitive enough to measure radiation from naturally-occurring radiation sources. The following table summarizes the measurements made for each monitoring location. The data were reported on July 6, 1980. The results are shown in millirem/hour (mrem/hr).

<u>Location</u>	<u>Average (mrem/hr)</u>	<u>Comment</u>
Fairview	0.009	Normal Background
Newberrytown	0.009	Normal Background
Goldsboro	0.015	Normal Background
York Haven	Data to EPA	
East Manchester	0.015	Normal Background
Lower Swatara	0.008	Normal Background
Middletown	0.010	Normal Background
Royalton	0.017	Normal Background
Londonderry	Data to EPA	
Conoy	0.013	Normal Background
West Donegal	0.015	Normal Background
Elizabethtown	0.008	Normal Background

BETA RATE RECORDERS (LUDLUM)

Beta rate recorders (Ludlum) are used to measure beta and gamma radiation levels at the monitoring site. The recorders are sensitive enough to measure radiation from naturally-occurring radiation sources.

9 stations recorded beta levels less than .005 m/rem an hour.

Following are beta skin dose levels for the 3 additional stations. These positive readings are above the .005 normal background reading.

York Haven	-	0.004 millirem
Londonderry	-	0.006 millirem
Conoy	-	0.015 millirem

Distribution:

EPA	DOE
NRC	Met-Ed
PEMA	GAC
Newsroom	PHS

COMMONWEALTH OF PENNSYLVANIA  
DEPARTMENT OF ENVIRONMENTAL RESOURCES  
HARRISBURG, PENNSYLVANIA

PRESS RELEASE  
Newsroom  
Contact: Amy Kelchner  
Telephone 717-787-2163  
July 8, 1980

FOR IMMEDIATE RELEASE

HARRISBURG — Following are the results of the Community Monitoring Program for July 7, 1980.

All readings for 11 stations were within the range of natural background levels for the sampling day ending July 7, 1980.

Conoy Twp. reported beta levels (Kr-85) above the normal background.

A more detailed summary of the results is attached.

### GAMMA RATE RECORDERS (LSI)

Gamma rate recorders (LSI) are used to measure gamma radiation levels at the monitoring site. The recorders are sensitive enough to measure radiation from naturally-occurring radiation sources. The following table summarizes the measurements made for each monitoring location. The data were reported on July 7, 1980. The results are shown in millirem/hour (mrem/hr).

<u>Location</u>	<u>Average (mrem/hr)</u>	<u>Comment</u>
Fairview	No report from Community Monitor	
Newberrytown	0.008	Normal Background
Goldsboro	0.014	Normal Background
York Haven	Data to EPA	
East Manchester	0.015	Normal Background
Lower Swatara	No report from Community Monitor	
Middletown	0.010	Normal Background
Royalton	0.016	Normal Background
Londonderry	Data to EPA	
Conoy	0.012	Normal Background
West Donegal	0.015	Normal Background
Elizabethtown	0.008	Normal Background

### BETA RATE RECORDERS (LUDLUM)

Beta rate recorders (Ludlum) are used to measure beta and gamma radiation levels at the monitoring site. The recorders are sensitive enough to measure radiation from naturally-occurring radiation sources.

11 stations recorded beta levels less than .005 m/rem an hour.

Conoy Twp. recorded a beta skin dose level of .007 millirem.

**Distribution:**

EPA	DOE
NRC	Met-Ed
PEMA	GAC
Newsroom	PHS

COMMONWEALTH OF PENNSYLVANIA  
DEPARTMENT OF ENVIRONMENTAL RESOURCES  
HARRISBURG, PENNSYLVANIA

PRESS RELEASE  
Newsroom  
Contact: Amy Kelchner  
Telephone 717-787-2163  
July 9, 1980

FOR IMMEDIATE RELEASE

HARRISBURG -- Following are the results of the Community Monitoring Program for July 8, 1980.

All readings for 10 stations were within the range of natural background levels for the sampling day ending July 8, 1980. Middletown and Royalton reported beta levels (Kr-85) above the normal background.

A more detailed summary of the results is attached.

GAMMA RATE RECORDERS (LSI)

Gamma rate recorders (LSI) are used to measure gamma radiation levels at the monitoring site. The recorders are sensitive enough to measure radiation from naturally-occurring radiation sources. The following table summarizes the measurements made for each monitoring location. The data were reported on July 8, 1980. The results are shown in millirem/hour (mrem/hr).

<u>Location</u>	<u>Average (mrem/hr)</u>	<u>Comment</u>
Fairview	0.010	Normal Background
Newberrytown	0.008	Normal Background
Goldsboro	0.015	Normal Background
York Haven	Data to EPA	
East Manchester	0.015	Normal Background
Lower Swatara	No report from Community Monitor	
Middletown	0.010	Normal Background
Royalton	0.016	Normal Background
Londonderry	Data to EPA	
Conoy	0.012	Normal Background
West Donegal	0.015	Normal Background
Elizabethtown	0.008	Normal Background

BETA RATE RECORDERS (LUDLUM)

Beta rate recorders (Ludlum) are used to measure beta and gamma radiation levels at the monitoring site. The recorders are sensitive enough to measure radiation from naturally-occurring radiation sources.

10 stations recorded beta levels less than .005 m/rem an hour.

Middletown recorded a beta skin dose level of .005 millirem.

Royalton recorded a beta skin dose level of .007 millirem.

Distribution:

EPA	DOE
NRC	Met-Ed
PEMA	GAC
Newsroom	PHS

COMMONWEALTH OF PENNSYLVANIA  
DEPARTMENT OF ENVIRONMENTAL RESOURCES  
HARRISBURG, PENNSYLVANIA

PRESS RELEASE  
Newsroom  
Contact: Amy Kelchner  
Telephone 717-787-2163  
July 10, 1980

FOR IMMEDIATE RELEASE

HARRISBURG -- Following are the results of the Community Monitoring Program for July 9, 1980.

All readings for 10 stations were within the range of natural background levels for the sampling day ending July 9, 1980. Elizabethtown and Conoy reported beta levels (Kr-85) above the normal background.

A more detailed summary of the results is attached.



### GAMMA RATE RECORDERS (LSI)

Gamma rate recorders (LSI) are used to measure gamma radiation levels at the monitoring site. The recorders are sensitive enough to measure radiation from naturally-occurring radiation sources. The following table summarizes the measurements made for each monitoring location. The data were reported on July 9, 1980. The results are shown in millirem/hour (mrem/hr).

<u>Location</u>	<u>Average (mrem/hr)</u>	<u>Comment</u>
Fairview	0.010	Normal Background
Newberrytown	0.008	Normal Background
Goldsboro	0.014	Normal Background
York Haven	Data to EPA	
East Manchester	0.014	Normal Background
Lower Swatara	0.008	Normal Background
Middletown	0.010	Normal Background
Royalton	0.017	Normal Background
Londonderry	Data to EPA	
Conoy	0.013	Normal Background
West Donegal	0.015	Normal Background
Elizabethtown	0.008	Normal Background

### BETA RATE RECORDERS (LUDLUM)

Beta rate recorders (Ludlum) are used to measure beta and gamma radiation levels at the monitoring site. The recorders are sensitive enough to measure radiation from naturally-occurring radiation sources.

Each station recorded beta levels less than .005 m/rem an hour.

Elizabethtown recorded a beta skin dose level of .015 millirem.

Conoy Twp. recorded a beta skin dose level of .003 millirem.

**Distribution:**

EPA	DOE
NRC	Met-Ed
PEMA	GAC
Newsroom	

### GAMMA RATE RECORDERS (LSI)

Gamma rate recorders (LSI) are used to measure gamma radiation levels at the monitoring site. The recorders are sensitive enough to measure radiation from naturally-occurring radiation sources. The following table summarizes the measurements made for each monitoring location. The data were reported on July 10, 1980. The results are shown in millirem/hour (mrem/hr).

<u>Location</u>	<u>Average (mrem/hr)</u>	<u>Comment</u>
Fairview	0.010	Normal Background
Newberrytown	0.009	Normal Background
Goldsboro	0.015	Normal Background
York Haven	Data to EPA	
East Manchester	0.013	Normal Background
Lower Swatara	No Report from Community Monitor	
Middletown	0.010	Normal Background
Royalton	0.017	Normal Background
Londonderry	Data to EPA	
Conoy	0.013	Normal Background
West Donegal	0.015	Normal Background
Elizabethtown	0.008	Normal Background

### BETA RATE RECORDERS (LUDLUM)

Beta rate recorders (Ludlum) are used to measure beta and gamma radiation levels at the monitoring site. The recorders are sensitive enough to measure radiation from naturally-occurring radiation sources.

Each station recorded beta levels less than .005 m/rem an hour.

**Distribution:**

EPA	DOE
NRC	Met-Ed
PEMA	GAC
Newsroom	PHS

GAMMA RATE RECORDERS (LSI)

Gamma rate recorders (LSI) are used to measure gamma radiation levels at the monitoring site. The recorders are sensitive enough to measure radiation from naturally-occurring radiation sources. The following table summarizes the measurements made for each monitoring location. The data were reported on July 11, 1980. The results are shown in millirem/hour (mrem/hr).

<u>Location</u>	<u>Average (mrem/hr)</u>	<u>Comment</u>
Fairview	0.011	Normal Background
Newberrytown	0.007	Normal Background
Goldsboro	0.015	Normal Background
York Haven	Data to EPA	
East Manchester	0.013	Normal Background
Lower Swatara	0.007	Normal Background
Middletown	0.010	Normal Background
Royalton	0.017	Normal Background
Londonderry	Data to EPA	
Conoy	0.014	Normal Background
West Donegal	0.015	Normal Background
Elizabethtown	0.008	Normal Background

BETA RATE RECORDERS (LUDLUM)

Beta rate recorders (Ludlum) are used to measure beta and gamma radiation levels at the monitoring site. The recorders are sensitive enough to measure radiation from naturally-occurring radiation sources.

Each station recorded beta levels less than .005 m/rem an hour.

Distribution:

EPA	DOE
NRC	Met-Ed
PEMA	GAC
Newsroom	

GAMMA RATE RECORDERS (LSI)

Gamma rate recorders (LSI) are used to measure gamma radiation levels at the monitoring site. The recorders are sensitive enough to measure radiation from naturally-occurring radiation sources. The following table summarizes the measurements made for each monitoring location. The data were reported on July 12, 1980. The results are shown in millirem/hour (mrem/hr).

<u>Location</u>	<u>Average (mrem/hr)</u>	<u>Comment</u>
Fairview	0.010	Normal Background
Newberrytown	0.008	Normal Background
Goldsboro	0.015	Normal Background
York Haven	Data to EPA	
East Manchester	Instrument Failure	
Lower Swatara	0.008	Normal Background
Middletown	0.010	Normal Background
Royalton	0.017	Normal Background
Londonderry	Data to EPA	
Conoy	0.014	Normal Background
West Donegal	0.015	Normal Background
Elizabethtown	0.008	Normal Background

BETA RATE RECORDERS (LUDLUM)

Beta rate recorders (Ludlum) are used to measure beta and gamma radiation levels at the monitoring site. The recorders are sensitive enough to measure radiation from naturally-occurring radiation sources.

Each station recorded beta levels less than .005 m/rem an hour.

Distribution:

EPA	DOE
NRC	Met-Ed
PEMA	GAC
Newsroom	

GAMMA RATE RECORDERS (LSI)

Gamma rate recorders (LSI) are used to measure gamma radiation levels at the monitoring site. The recorders are sensitive enough to measure radiation from naturally-occurring radiation sources. The following table summarizes the measurements made for each monitoring location. The data were reported on July 13, 1980. The results are shown in millirem/hour (mrem/hr).

<u>Location</u>	<u>Average (mrem/hr)</u>	<u>Comment</u>
Fairview	0.010	Normal Background
Newberrytown	Instrument Failure	
Goldsboro	0.015	Normal Background
York Haven	Data to EPA	
East Manchester	No report from Community Monitor	
Lower Swatara	0.008	Normal Background
Middletown	0.010	Normal Background
Royalton	0.016	Normal Background
Londonderry	Data to EPA	
Conoy	0.014	Normal Background
West Donegal	0.015	Normal Background
Elizabethtown	0.008	Normal Background

BETA RATE RECORDERS (LUDLUM)

Beta rate recorders (Ludlum) are used to measure beta and gamma radiation levels at the monitoring site. The recorders are sensitive enough to measure radiation from naturally-occurring radiation sources.

Each station recorded beta levels less than .005 m/rem an hour.

Distribution:

EPA	DOE
NRC	Met-Ed
PEMA	GAC
Newsroom	

### GAMMA RATE RECORDERS (LSI)

Gamma rate recorders (LSI) are used to measure gamma radiation levels at the monitoring site. The recorders are sensitive enough to measure radiation from naturally-occurring radiation sources. The following table summarizes the measurements made for each monitoring location. The data were reported on July 14, 1980. The results are shown in millirem/hour (mrem/hr).

<u>Location</u>	<u>Average (mrem/hr)</u>	<u>Comment</u>
Fairview	0.011	Normal Background
Newberrytown	0.008	Normal Background
Goldsboro	0.015	Normal Background
York Haven	No Report from Community Monitor	
East Manchester	Instrument Failure	
Lower Swatara	0.008	Normal Background
Middletown	0.010	Normal Background
Royalton	0.017	Normal Background
Londonderry	Data to EPA	
Conoy	Instrument Failure	
West Donegal	0.008	Normal Background
Elizabethtown		

### BETA RATE RECORDERS (LUDLUM)

Beta rate recorders (Ludlum) are used to measure beta and gamma radiation levels at the monitoring site. The recorders are sensitive enough to measure radiation from naturally-occurring radiation sources.

Each station recorded beta levels less than .005 m/rem an hour.

**Distribution:**

EPA	DOE
NRC	Met-Ed
PEMA	GAC
Newsroom	

GAMMA RATE RECORDERS (LSI)

Gamma rate recorders (LSI) are used to measure gamma radiation levels at the monitoring site. The recorders are sensitive enough to measure radiation from naturally-occurring radiation sources. The following table summarizes the measurements made for each monitoring location. The data were reported on July 16, 1980. The results are shown in millirem/hour (mrem/hr).

<u>Location</u>	<u>Average (mrem/hr)</u>	<u>Comment</u>
Fairview	No Report from Community Monitor	
Newberrytown	0.009	Normal Background
Goldsboro	Readings Reduced to Twice Weekly	
York Haven	Data to EPA	
East Manchester	No Instrument	
Lower Swatara	0.008	Normal Background
Middletown	No Report from Community Monitor	
Royalton	0.017	Normal Background
Londonderry	Data to EPA	
Conoy	No Report from Community Monitor	
West Donegal	No Report from Community Monitor	
Elizabethtown	0.008	Normal Background

BETA RATE RECORDERS (LUDLUM)

Beta rate recorders (Ludlum) are used to measure beta and gamma radiation levels at the monitoring site. The recorders are sensitive enough to measure radiation from naturally-occurring radiation sources.

Each station recorded beta levels less than .005 m/rem an hour.

Distribution:

EPA	DOE
NRC	Met-Ed
PEMA	GAC
Newsroom	

GAMMA RATE RECORDERS (LSI)

Gamma rate recorders (LSI) are used to measure gamma radiation levels at the monitoring site. The recorders are sensitive enough to measure radiation from naturally-occurring radiation sources. The following table summarizes the measurements made for each monitoring location. The data were reported on July 17, 1980. The results are shown in millirem/hour (mrem/hr):

<u>Location</u>	<u>Average (mrem/hr)</u>	<u>Comment</u>
Fairview	0.011	Normal Background
Newberrytown	No report from Community Monitor	
Goldsboro	0.015	Normal Background
York Haven	Data to EPA	
East Manchester	No Instrument	
Lower Swatara	No report from Community Monitor	
Middletown	0.010	Normal Background
Royalton	0.016	Normal Background
Londonderry	Data to EPA	
Conoy	No report from Community Monitor	
West Donegal	0.015	Normal Background
Elizabethtown	0.008	Normal Background

BETA RATE RECORDERS (LUDLUM)

Beta rate recorders (Ludlum) are used to measure beta and gamma radiation levels at the monitoring site. The recorders are sensitive enough to measure radiation from naturally-occurring radiation sources.

Each station recorded beta levels less than .005 m/rem an hour.

Distribution:

EPA	DOE
NRC	Met-Ed
PEMA	GAC
Newsroom	



### GAMMA RATE RECORDERS (LSI)

Gamma rate recorders (LSI) are used to measure gamma radiation levels at the monitoring site. The recorders are sensitive enough to measure radiation from naturally-occurring radiation sources. The following table summarizes the measurements made for each monitoring location. The data were reported on July 15, 1980. The results are shown in millirem/hour (mrem/hr).

<u>Location</u>	<u>Average (mrem/hr)</u>	<u>Comment</u>
Fairview	0.011	Normal Background
Newberrytown	0.008	Normal Background
Goldsboro	Readings reduced to twice weekly	
York Haven	Data to EPA	
East Manchester	No Instrument	
Lower Swatara	0.008	Normal Background
Middletown	0.010	Normal Background
Royalton	0.016	Normal Background
Londonderry	Data to EPA	
Conoy	No Report from Community Monitor	
West Donegal	0.015	Normal Background
Elizabethtown	No Tape Available	

### BETA RATE RECORDERS (LUDLUM)

Beta rate recorders (Ludlum) are used to measure beta and gamma radiation levels at the monitoring site. The recorders are sensitive enough to measure radiation from naturally-occurring radiation sources.

Each station recorded beta levels less than .005 m/rem an hour.

**Distribution:**

EPA	DOE
NRC	Met-Ed
PEMA	GAC
Newsroom	

GAMMA RATE RECORDERS (LSI)

Gamma rate recorders (LSI) are used to measure gamma radiation levels at the monitoring site. The recorders are sensitive enough to measure radiation from naturally-occurring radiation sources. The following table summarizes the measurements made for each monitoring location. The data were reported on July 18, 1980. The results are shown in millirem/hour (mrem/hr).

<u>Location</u>	<u>Average (mrem/hr)</u>	<u>Comment</u>
Fairview	0.010	Normal Background
Newberrytown	0.009	Normal Background
Goldsboro	Readings reduced to twice weekly	
York Haven	Data to EPA	
East Manchester	No Instrument	
Lower Swatara	No report from Community Monitor	
Middletown	Instrument Failure	
Royalton	Instrument Removed	
Londonderry	Data to EPA	
Conoy	No report from Community Monitor	
West Donegal	0.015	Normal Background
Elizabethtown	0.008	Normal Background

BETA RATE RECORDERS (LUDLUM)

Beta rate recorders (Ludlum) are used to measure beta and gamma radiation levels at the monitoring site. The recorders are sensitive enough to measure radiation from naturally-occurring radiation sources.

Each station recorded beta levels less than .005 m/rem an hour.

Distribution:

EPA	DOE
NRC	Met-Ed
PEMA	GAC
Newsroom	

GAMMA RATE RECORDERS (LSI)

Gamma rate recorders (LSI) are used to measure gamma radiation levels at the monitoring site. The recorders are sensitive enough to measure radiation from naturally-occurring radiation sources. The following table summarizes the measurements made for each monitoring location. The data were reported on July 19, 1980. The results are shown in millirem/hour (mrem/hr).

<u>Location</u>	<u>Average (mrem/hr)</u>	<u>Comment</u>
Fairview	0.010	Normal Background
Newberrytown	0.008	Normal Background
Goldsboro	Readings reduced to twice weekly	
York Haven	Data to EPA	
East Manchester	No Instrument	
Lower Swatara	No report from Community Monitor	
Middletown	Instrument Failure	
Royalton	Instrument Removed	
Londonderry	No report from Community Monitor	
Conoy	No report from Community Monitor	
West Donegal	0.015	Normal Background
Elizabethtown	0.008	Normal Background

BETA RATE RECORDERS (LUDLUM)

Beta rate recorders (Ludlum) are used to measure beta and gamma radiation levels at the monitoring site. The recorders are sensitive enough to measure radiation from naturally-occurring radiation sources.

Each station recorded beta levels less than .005 m/rem an hour.

Distribution:

EPA	DOE
NRC	Met-Ed
PEMA	GAC
Newsroom	

### GAMMA RATE RECORDERS (LSI)

Gamma rate recorders (LSI) are used to measure gamma radiation levels at the monitoring site. The recorders are sensitive enough to measure radiation from naturally-occurring radiation sources. The following table summarizes the measurements made for each monitoring location. The data were reported on August 3, 1980. The results are shown in millirem/hour (mrem/hr).

<u>Location</u>	<u>Average (mrem/hr)</u>	<u>Comment</u>
Fairview	0.010	Normal Background
Newberrytown	Readings Reduced to 3 Times Weekly	
Goldsboro	Readings Reduced to Twice Weekly	
York Haven	Readings Reduced to Twice Weekly	
East Manchester	No Instrument	
Lower Swatara	No Report from Community Monitor	
Middletown	No Instrument	
Royalton	No Instrument	
Londonderry	No Report from Community Monitor	
Conoy	No Instrument	
West Donegal	No Report from Community Monitor	
Elizabethtown	No Instrument	

### BETA RATE RECORDERS (LUDLUM)

Beta rate recorders (Ludlum) are used to measure beta and gamma radiation levels at the monitoring site. The recorders are sensitive enough to measure radiation from naturally-occurring radiation sources.

Each station recorded beta levels less than .005 m/rem an hour.

**Distribution:**

EPA	DOE
NRC	Met-Ed
PEMA	GAC
Newsroom	

### GAMMA RATE RECORDERS (LSI)

Gamma rate recorders (LSI) are used to measure gamma radiation levels at the monitoring site. The recorders are sensitive enough to measure radiation from naturally-occurring radiation sources. The following table summarizes the measurements made for each monitoring location. The data were reported on July 20, 1980. The results are shown in millirem/hour (mrem/hr).

<u>Location</u>	<u>Average (mrem/hr)</u>	<u>Comment</u>
Fairview	0.011	Normal Background
Newberrytown	No report from Community Monitor	
Goldsboro	Readings reduced to twice weekly	
York Haven	Data to EPA	
East Manchester	No Instrument	
Lower Swatara	No report from Community Monitor	
Middletown	Instrument Failure	
Royalton	Instrument Removed	
Londonderry	No report from Community Monitor	
Conoy	No report from Community Monitor	
West Donegal	0.015	Normal Background
Elizabethtown	0.008	Normal Background

### BETA RATE RECORDERS (LUDLUM)

Beta rate recorders (Ludlum) are used to measure beta and gamma radiation levels at the monitoring site. The recorders are sensitive enough to measure radiation from naturally-occurring radiation sources.

Each station recorded beta levels less than .005 m/rem an hour.

**Distribution:**

EPA	DOE
NRC	Met-Ed
PEMA	GAC
Newsroom	

COMMONWEALTH OF PENNSYLVANIA  
DEPARTMENT OF ENVIRONMENTAL RESOURCES  
HARRISBURG, PENNSYLVANIA

PRESS RELEASE  
Newsroom  
Contact: Amy Kelchner  
Telephone 717-787-2163  
July 22, 1980

FOR IMMEDIATE RELEASE

HARRISBURG -- Following are the results of the Community Monitoring Program for July 21, 1980.

All readings were within the range of natural background levels for the sampling day ending July 21, 1980.

A more detailed summary of the results is attached.

Because the venting of Krypton-85 from Three Mile Island Unit II has been concluded, today will be the last day that the results of the Community Monitoring Program will be released on a daily basis.

Any unusual readings will be released to the press as they are found.

The data will still be compiled daily and is available by contacting the Bureau of Radiation Protection office. Data will also be distributed to the USNRC, EPA, Metropolitan Edison, PEMA and the Governor's Action Center.

GAMMA RATE RECORDERS (LSI)

Gamma rate recorders (LSI) are used to measure gamma radiation levels at the monitoring site. The recorders are sensitive enough to measure radiation from naturally-occurring radiation sources. The following table summarizes the measurements made for each monitoring location. The data were reported on July 21, 1980. The results are shown in millirem/hour (mrem/hr).

<u>Location</u>	<u>Average (mrem/hr)</u>	<u>Comment</u>
Fairview	0.013	Normal Background
Newberrytown	0.009	Normal Background
Goldsboro	0.015	Normal Background
York Haven	Data to EPA	
East Manchester	No Instrument	
Lower Swatara	No Report from Community Monitor	
Middletown	Instrument Failure	
Royalton	No Instrument	
Londonderry	Data to EPA	
Conoy	No Report from Community Monitor	
West Donegal	0.015	Normal Background
Elizabethtown	0.008	Normal Background

BETA RATE RECORDERS (LUDLUM)

Beta rate recorders (Ludlum) are used to measure beta and gamma radiation levels at the monitoring site. The recorders are sensitive enough to measure radiation from naturally-occurring radiation sources.

Each station recorded beta levels less than .005 m/rem an hour.

Distribution:

EPA	DOE
NRC	Met-Ed
PEMA	GAC
Newsroom	

### GAMMA RATE RECORDERS (LSI)

Gamma rate recorders (LSI) are used to measure gamma radiation levels at the monitoring site. The recorders are sensitive enough to measure radiation from naturally-occurring radiation sources. The following table summarizes the measurements made for each monitoring location. The data were reported on July 22, 1980. The results are shown in millirem/hour (mrem/hr).

<u>Location</u>	<u>Average (mrem/hr)</u>	<u>Comment</u>
Fairview	0.011.	Normal Background
Newberrytown	No report from Community Monitor	
Goldsboro	Readings reduced to twice weekly	
York Haven	Data to EPA	
East Manchester	Readings reduced to twice weekly	
Lower Swatara	No report from Community Monitor	
Middletown	No Instrument	
Royalton	No Instrument	
Londonderry	Data to EPA	
Conoy	No report from Community Monitor	
West Donegal	0.015	Normal Background
Elizabethtown	Instrument Removed	

### BETA RATE RECORDERS (LUDLUM)

Beta rate recorders (Ludlum) are used to measure beta and gamma radiation levels at the monitoring site. The recorders are sensitive enough to measure radiation from naturally-occurring radiation sources.

Each station recorded beta levels less than .005 m/rem an hour.

Distribution:  
 EPA  
 NRC



### GAMMA RATE RECORDERS (LSI)

Gamma rate recorders (LSI) are used to measure gamma radiation levels at the monitoring site. The recorders are sensitive enough to measure radiation from naturally-occurring radiation sources. The following table summarizes the measurements made for each monitoring location. The data were reported on July 23, 1980. The results are shown in millirem/hour (mrem/hr).

<u>Location</u>	<u>Average (mrem/hr)</u>	<u>Comment</u>
Fairview	0.013	Normal Background
Newberrytown	0.009	Normal Background
Goldsboro	Readings reduced to twice weekly	
York Haven	Data to EPA	
East Manchester	No Instrument	
Lower Swatara	No report from Community Monitor	
Middletown	No Instrument	
Royalton	No Instrument	
Londonderry	Data to EPA	
Conoy	0.013	Normal Background
West Donegal	0.015	Normal Background
Elizabethtown	0.008	Normal Background

### BETA RATE RECORDERS (LUDLUM)

Beta rate recorders (Ludlum) are used to measure beta and gamma radiation levels at the monitoring site. The recorders are sensitive enough to measure radiation from naturally-occurring radiation sources.

Each station recorded beta levels less than .005 m/rem an hour.

**Distribution:**

EPA	DOE
NRC	Met-Ed
PEMA	GAC
Newsroom	

### GAMMA RATE RECORDERS (LSI)

Gamma rate recorders (LSI) are used to measure gamma radiation levels at the monitoring site. The recorders are sensitive enough to measure radiation from naturally-occurring radiation sources. The following table summarizes the measurements made for each monitoring location. The data were reported on July 24, 1980. The results are shown in millirem/hour (mrem/hr).

<u>Location</u>	<u>Average (mrem/hr)</u>	<u>Comment</u>
Fairview	0.013	Normal Background
Newberrytown	0.008	Normal Background
Goldsboro	Readings Taken Twice Weekly	
York Haven	Data to EPA	
East Manchester	Readings Taken Twice Weekly	
Lower Swatara	No Report from Community Monitor	
Middletown	No Instrument	
Royalton	No Instrument	
Londonderry	Data to EPA	
Conoy	No Report from Community Monitor	
West Donegal	0.015	Normal Background
Elizabethtown	0.008	Normal Background

### BETA RATE RECORDERS (LUDLUM)

Beta rate recorders (Ludlum) are used to measure beta and gamma radiation levels at the monitoring site. The recorders are sensitive enough to measure radiation from naturally-occurring radiation sources.

Each station recorded beta levels less than .005 m/rem an hour.

**Distribution:**

EPA	DOE
NRC	Met-Ed
PEMA	GAC
Newsroom	

GAMMA RATE RECORDERS (LSI)

Gamma rate recorders (LSI) are used to measure gamma radiation levels at the monitoring site. The recorders are sensitive enough to measure radiation from naturally-occurring radiation sources. The following table summarizes the measurements made for each monitoring location. The data were reported on July 25, 1980. The results are shown in millirem/hour (mrem/hr).

<u>Location</u>	<u>Average (mrem/hr)</u>	<u>Comment</u>
Fairview	0.012	Normal Background
Newberrytown	No Data Available	
Goldsboro	Readings reduced to twice weekly	
York Haven	Data to EPA	
East Manchester	Readings reduced to twice weekly	
Lower Swatara	No Instrument	
Middletown	No Instrument	
Royalton	No Instrument	
Londonderry	Data to EPA	
Conoy	No report from Community Monitor	
West Donegal	0.015	Normal Background
Elizabethtown	No Instrument	

BETA RATE RECORDERS (LUDLUM)

Beta rate recorders (Ludlum) are used to measure beta and gamma radiation levels at the monitoring site. The recorders are sensitive enough to measure radiation from naturally-occurring radiation sources.

Each station recorded beta levels less than .005 m/rem an hour.

Distribution:

EPA	DOE
NRC	Met-Ed
PEMA	GAC
Newsroom	

### GAMMA RATE RECORDERS (LSI)

Gamma rate recorders (LSI) are used to measure gamma radiation levels at the monitoring site. The recorders are sensitive enough to measure radiation from naturally-occurring radiation sources. The following table summarizes the measurements made for each monitoring location. The data were reported on July 26, 1980. The results are shown in millirem/hour (mrem/hr).

<u>Location</u>	<u>Average (mrem/hr)</u>	<u>Comment</u>
Fairview	0.010	Normal Background
Newberrytown	No report	
Goldsboro	Readings reduced to twice weekly	
York Haven	No report from Community Monitor	
East Manchester	Readings reduced to twice weekly	
Lower Swatara	No Instrument	
Middletown	No Instrument	
Royalton	No Instrument	
Londonderry	No report from Community Monitor	
Conoy	No report from Community Monitor	
West Donegal	0.015	Normal Background
Elizabethtown	No Instrument	

### BETA RATE RECORDERS (LUDLUM)

Beta rate recorders (Ludlum) are used to measure beta and gamma radiation levels at the monitoring site. The recorders are sensitive enough to measure radiation from naturally-occurring radiation sources.

Each station recorded beta levels less than .005 m/rem an hour.

**Distribution:**

EPA	DOE
NRC	Met-Ed
PEMA	GAC
Newsroom	

### GAMMA RATE RECORDERS (LSI)

Gamma rate recorders (LSI) are used to measure gamma radiation levels at the monitoring site. The recorders are sensitive enough to measure radiation from naturally-occurring radiation sources. The following table summarizes the measurements made for each monitoring location. The data were reported on July 27, 1980. The results are shown in millirem/hour (mrem/hr).

<u>Location</u>	<u>Average (mrem/hr)</u>	<u>Comment</u>
Fairview	No report from Community Monitor	
Newberrytown	No report	
Goldsboro	Readings reduced to twice weekly	
York Haven	No report from Community Monitor	
East Manchester	Readings reduced to twice weekly	
Lower Swatara	No Instrument	
Middletown	No Instrument	
Royalton	No Instrument	
Londonderry	No report from Community Monitor	
Conoy	No report from Community Monitor	
West Donegal	0.015	Normal Background
Elizabethtown	No Instrument	

### BETA RATE RECORDERS (LUDLUM)

Beta rate recorders (Ludlum) are used to measure beta and gamma radiation levels at the monitoring site. The recorders are sensitive enough to measure radiation from naturally-occurring radiation sources.

Each station recorded beta levels less than .005 m/rem an hour.

**Distribution:**

EPA	DOE
NRC	Met-Ed
PEMA	GAC
Newsroom	

GAMMA RATE RECORDERS (LSI)

Gamma rate recorders (LSI) are used to measure gamma radiation levels at the monitoring site. The recorders are sensitive enough to measure radiation from naturally-occurring radiation sources. The following table summarizes the measurements made for each monitoring location. The data were reported on August 7, 1980. The results are shown in millirem/hour (mrem/hr).

<u>Location</u>	<u>Average (mrem/hr)</u>	<u>Comment</u>
Fairview	0.011	Normal Background
Newberrytown	Readings Reduced to 3 Times Weekly	
Goldsboro	Readings Reduced to Twice Weekly	
York Haven	Data to EPA	
East Manchester	No Instrument	
Lower Swatara	No Instrument	
Middletown	No Instrument	
Royalton	No Instrument	
Londonderry	Data to EPA	
Conoy	Readings Reduced	
West Donegal	Readings Reduced	
Elizabethtown	No Instrument	

BETA RATE RECORDERS (LUDLUM)

Beta rate recorders (Ludlum) are used to measure beta and gamma radiation levels at the monitoring site. The recorders are sensitive enough to measure radiation from naturally-occurring radiation sources.

Each station recorded beta levels less than .005 m/rem an hour.

Distribution:

EPA	DOE
NRC	Met-Ed
PEMA	GAC
Newsroom	

GAMMA RATE RECORDERS (LSI)

Gamma rate recorders (LSI) are used to measure gamma radiation levels at the monitoring site. The recorders are sensitive enough to measure radiation from naturally-occurring radiation sources. The following table summarizes the measurements made for each monitoring location. The data were reported on August 6, 1980. The results are shown in millirem/hour (mrem/hr).

<u>Location</u>	<u>Average (mrem/hr)</u>	<u>Comment</u>
Fairview	0.010	Normal Background
Newberrytown	0.009	Normal Background
Goldsboro	No Instrument	
York Haven	Data to EPA	
East Manchester	No Instrument	
Lower Swatara	No Instrument	
Middletown	No Instrument	
Royalton	No Instrument	
Londonderry	Data to EPA	
Conoy	No Instrument	
West Donegal	0.015	Normal Background
Elizabethtown	No Instrument	

BETA RATE RECORDERS (LUDLUM)

Beta rate recorders (Ludlum) are used to measure beta and gamma radiation levels at the monitoring site. The recorders are sensitive enough to measure radiation from naturally-occurring radiation sources.

Each station recorded beta levels less than .005 m/rem an hour.

Distribution:

EPA	DOE
NRC	Met-Ed
PEMA	GAC
Newsroom	

GAMMA RATE RECORDERS (LSI)

Gamma rate recorders (LSI) are used to measure gamma radiation levels at the monitoring site. The recorders are sensitive enough to measure radiation from naturally-occurring radiation sources. The following table summarizes the measurements made for each monitoring location. The data were reported on August 5, 1980. The results are shown in millirem/hour (mrem/hr).

<u>Location</u>	<u>Average (mrem/hr)</u>	<u>Comment</u>
Fairview	0.011.	Normal Background
Newberrytown	Readings Reduced to 3 Times Weekly	
Goldsboro	Readings Reduced to Twice Weekly	
York Haven	Data to EPA	
East Manchester	Readings Reduced to Twice Weekly	
Lower Swatara	Reduced Readings	
Middletown	Readings Reduced to 3 Times Weekly	
Royalton	No Instrument	
Londonderry	Data to EPA	
Conoy	No Instrument	
West Donegal	No Report from Community Monitor	
Elizabethtown	No Instrument	

BETA RATE RECORDERS (LUDLUM)

Beta rate recorders (Ludlum) are used to measure beta and gamma radiation levels at the monitoring site. The recorders are sensitive enough to measure radiation from naturally-occurring radiation sources.

Each station recorded beta levels less than .005 m/rem an hour.

Distribution:

EPA	DOE
NRC	Met-Ed
PEMA	GAC
Newsroom	



### GAMMA RATE RECORDERS (LSI)

Gamma rate recorders (LSI) are used to measure gamma radiation levels at the monitoring site. The recorders are sensitive enough to measure radiation from naturally-occurring radiation sources. The following table summarizes the measurements made for each monitoring location. The data were reported on August 4, 1980. The results are shown in millirem/hour (mrem/hr).

<u>Location</u>	<u>Average (mrem/hr)</u>	<u>Comment</u>
Fairview	0.010.	Normal Background
Newberrytown	Readings Reduced to 3 Times Weekly	
Goldsboro	No Instrument	
York Haven	Data to EPA	
East Manchester	Readings Reduced to Twice Weekly	
Lower Swatara	Readings Reduced to Twice Weekly	
Middletown	No Instrument	
Royalton	No Instrument	
Londonderry	Data to EPA	
Conoy	Reduced Readings	
West Donegal	No Report from Community Monitor	
Elizabethtown	No Report from Community Monitor	

### BETA RATE RECORDERS (LUDLUM)

Beta rate recorders (Ludlum) are used to measure beta and gamma radiation levels at the monitoring site. The recorders are sensitive enough to measure radiation from naturally-occurring radiation sources.

Each station recorded beta levels less than .005 m/rem an hour.

**Distribution:**

EPA	DOE
NRC	Met-Ed
PEMA	GAC
Newsroom	

### GAMMA RATE RECORDERS (LSI)

Gamma rate recorders (LSI) are used to measure gamma radiation levels at the monitoring site. The recorders are sensitive enough to measure radiation from naturally-occurring radiation sources. The following table summarizes the measurements made for each monitoring location. The data were reported on August 2, 1980. The results are shown in millirem/hour (mrem/hr).

<u>Location</u>	<u>Average (mrem/hr)</u>	<u>Comment</u>
Fairview	0.010	Normal Background
Newberrytown	Readings Reduced to 3 Times Weekly	
Goldsboro	Readings Reduced to Twice Weekly	
York Haven	Readings Reduced to Twice Weekly	
East Manchester	No Instrument	
Lower Swatara	No Report from Community Monitor	
Middletown	No Instrument	
Royalton	No Instrument	
Londonderry	No Report from Community Monitor	
Conoy	No Instrument	
West Donegal	No Report from Community Monitor	
Elizabethtown	No Instrument	

### BETA RATE RECORDERS (LUDLUM)

Beta rate recorders (Ludlum) are used to measure beta and gamma radiation levels at the monitoring site. The recorders are sensitive enough to measure radiation from naturally-occurring radiation sources.

Each station recorded beta levels less than .005 m/rem an hour.

#### Distribution:

EPA	DOE
NRC	Met-Ed
PEMA	GAC
Newsroom	

### GAMMA RATE RECORDERS (LSI)

Gamma rate recorders (LSI) are used to measure gamma radiation levels at the monitoring site. The recorders are sensitive enough to measure radiation from naturally-occurring radiation sources. The following table summarizes the measurements made for each monitoring location. The data were reported on August 1, 1980. The results are shown in millirem/hour (mrem/hr).

<u>Location</u>	<u>Average (mrem/hr)</u>	<u>Comment</u>
Fairview	0.010	Normal Background
Newberrytown	Readings Reduced to 3 Times Weekly	
Goldsboro	Readings Reduced to Twice Weekly	
York Haven	Readings Reduced to Twice Weekly	
East Manchester	No Instrument	
Lower Swatara	No Report from Community Monitor	
Middletown	No Instrument	
Royalton	No Instrument	
Londonderry	Data to EPA	
Conoy	No Instrument	
West Donegal	0.015	
Elizabethtown	No Instrument	

### BETA RATE RECORDERS (LUDLUM)

Beta rate recorders (Ludlum) are used to measure beta and gamma radiation levels at the monitoring site. The recorders are sensitive enough to measure radiation from naturally-occurring radiation sources.

Each station recorded beta levels less than .005 m/rem an hour.

**Distribution:**

EPA	DOE
NRC	Met-Ed
PEMA	GAC
Newsroom	

GAMMA RATE RECORDERS (LSI)

Gamma rate recorders (LSI) are used to measure gamma radiation levels at the monitoring site. The recorders are sensitive enough to measure radiation from naturally-occurring radiation sources. The following table summarizes the measurements made for each monitoring location. The data were reported on July 31, 1980. The results are shown in millirem/hour (mrem/hr).

<u>Location</u>	<u>Average (mrem/hr)</u>	<u>Comment</u>
Fairview	0.012	Normal Background
Newberrytown	0.008	Normal Background
Goldsboro	No Instrument	
York Haven	Data to EPA	
East Manchester	Readings Reduced to Twice Weekly	
Lower Swatara	No Report from Community Monitor	
Middletown	No Instrument	
Royalton	No Instrument	
Londonderry	No Report from Community Monitor	
Conoy	No Report from Community Monitor	
West Donegal	0.015	Normal Background
Elizabethtown	No Instrument	

BETA RATE RECORDERS (LUDLUM)

Beta rate recorders (Ludlum) are used to measure beta and gamma radiation levels at the monitoring site. The recorders are sensitive enough to measure radiation from naturally-occurring radiation sources.

Each station recorded beta levels less than .005 m/rem an hour.

Distribution:

EPA	DOE
NRC	Met-Ed
PEMA	GAC
Newsroom	

GAMMA RATE RECORDERS (LSI)

Gamma rate recorders (LSI) are used to measure gamma radiation levels at the monitoring site. The recorders are sensitive enough to measure radiation from naturally-occurring radiation sources. The following table summarizes the measurements made for each monitoring location. The data were reported on July 30, 1980. The results are shown in millirem/hour (mrem/hr).

<u>Location</u>	<u>Average (mrem/hr)</u>	<u>Comment</u>
Fairview	0.013	Normal Background
Newberrytown	0.009	Normal Background
Goldsboro	Readings Reduced to Twice Weekly	
York Haven	Data to EPA	
East Manchester	No Instrument	
Lower Swatara	No Instrument	
Middletown	No Instrument	
Royalton	No Instrument	
Londonderry	Data to EPA	
Conoy	Instrument Failure	
West Donegal	0.015	Normal Background
Elizabethtown	No Instrument	

BETA RATE RECORDERS (LUDLUM)

Beta rate recorders (Ludlum) are used to measure beta and gamma radiation levels at the monitoring site. The recorders are sensitive enough to measure radiation from naturally-occurring radiation sources.

Each station recorded beta levels less than .005 m/rem an hour.

Distribution:

EPA	DOE
NRC	Met-Ed
PEMA	GAC
Newsroom	

GAMMA RATE RECORDERS (LSI)

Gamma rate recorders (LSI) are used to measure gamma radiation levels at the monitoring site. The recorders are sensitive enough to measure radiation from naturally-occurring radiation sources. The following table summarizes the measurements made for each monitoring location. The data were reported on July 29, 1980. The results are shown in millirem/hour (mrem/hr).

<u>Location</u>	<u>Average (mrem/hr)</u>	<u>Comment</u>
Fairview	0.011	Normal Background
Newberrytown	No Report from Community Monitor	
Goldsboro	Readings Reduced to Twice Weekly	
York Haven	Data to EPA	
East Manchester	Readings Reduced to Twice Weekly	
Lower Swatara	No Report from Community Monitor	
Middletown	No Instrument	
Royalton	No Instrument	
Londonderry	Data to EPA	
Conoy	No Report from Community Monitor	
West Donegal	0.015	Normal Background
Elizabethtown	No Instrument	

BETA RATE RECORDERS (LUDLUM)

Beta rate recorders (Ludlum) are used to measure beta and gamma radiation levels at the monitoring site. The recorders are sensitive enough to measure radiation from naturally-occurring radiation sources.

Each station recorded beta levels less than .005 m/rem an hour.

Distribution:

EPA	DOE
NRC	Met-Ed
PEMA	GAC
Newroom	

### GAMMA RATE RECORDERS (LSI)

Gamma rate recorders (LSI) are used to measure gamma radiation levels at the monitoring site. The recorders are sensitive enough to measure radiation from naturally-occurring radiation sources. The following table summarizes the measurements made for each monitoring location. The data were reported on July 28, 1980. The results are shown in millirem/hour (mrem/hr).

<u>Location</u>	<u>Average (mrem/hr)</u>	<u>Comment</u>
Fairview	0.012	Normal Background
Newberrytown	0.009	Normal Background
Goldsboro	Instrument Failure	
York Haven	Data to EPA	
East Manchester	No Instrument	
Lower Swatara	No Report from Community Monitor	
Middletown	No Instrument	
Royalton	No Report from Community Monitor	
Londonderry	Data to EPA	
Conoy	0.012	Normal Background
West Donegal	0.015	Normal Background
Elizabethtown	No Instrument	

### BETA RATE RECORDERS (LUDLUM)

Beta rate recorders (Ludlum) are used to measure beta and gamma radiation levels at the monitoring site. The recorders are sensitive enough to measure radiation from naturally-occurring radiation sources.

Each station recorded beta levels less than .005 m/rem an hour.

**Distribution:**

EPA	DOE
NRC	Met-Ed
PEMA	GAC
Newsroom	

### GAMMA RATE RECORDERS (LSI)

Gamma rate recorders (LSI) are used to measure gamma radiation levels at the monitoring site. The recorders are sensitive enough to measure radiation from naturally-occurring radiation sources. The following table summarizes the measurements made for each monitoring location. The data were reported on May 28, 1980. The results are shown in millirem/hour (mrem/hr).

<u>Location</u>	<u>Average (mrem/hr)</u>	<u>Comment</u>
Fairview	0.009	Normal Background
Newberrytown	0.008	Normal Background
Goldsboro	0.014	Normal Background
York Haven	Data to EPA	
East Manchester	No Instrument	
Lower Swatara	0.006	Normal Background
Middletown	0.010	Normal Background
Royalton	0.015	Normal Background
Londonderry	Data to EPA	
Conoy	No Data Available	
West Donegal	0.009	Normal Background
Elizabethtown	No Instrument	

### BETA RATE RECORDERS (LUDLUM)

Beta rate recorders (Ludlum) are used to measure beta and gamma radiation levels at the monitoring site. The recorders are sensitive enough to measure radiation from naturally-occurring radiation sources.

Each station recorded beta levels less than .005 m/rem an hour.

**Distribution:**

EPA	DOE
NRC	Met-Ed
PEMA	GAC
Newsroom	



COMMONWEALTH OF PENNSYLVANIA  
DEPARTMENT OF ENVIRONMENTAL RESOURCES  
HARRISBURG, PENNSYLVANIA

PRESS RELEASE  
Newsroom  
Contact: Amy Keichner  
Telephone: 717-787-2163  
May 30, 1980

FOR IMMEDIATE RELEASE

HARRISBURG -- Following are the results of the Community Monitoring program  
for May 29, 1980 :

All readings were within the range of natural background  
levels for the sampling day ending May 29, 1980. A more  
detailed summary of the results is attached.

### GAMMA RATE RECORDERS (LSI)

Gamma rate recorders (LSI) are used to measure gamma radiation levels at the monitoring site. The recorders are sensitive enough to measure radiation from naturally-occurring radiation sources. The following table summarizes the measurements made for each monitoring location. The data were reported on May 29, 1980. The results are shown in millirem/hour (mrem/hr).

<u>Location</u>	<u>Average (mrem/hr)</u>	<u>Comment</u>
Fairview	0.009	Normal Background
Newberrytown	0.008	Normal Background
Goldsboro	0.013	Normal Background
York Haven	Data to EPA	
East Manchester	No Instrument	
Lower Swatara	0.007	Normal Background
Middletown	0.010	Normal Background
Royalton	0.016	Normal Background
Londonderry	Data to EPA	
Conoy	0.014	Normal Background
West Donegal	0.009	Normal Background
Elizabethtown	No Instrument	

### BETA RATE RECORDERS (LUDLUM)

Beta rate recorders (Ludlum) are used to measure beta and gamma radiation levels at the monitoring site. The recorders are sensitive enough to measure radiation from naturally-occurring radiation sources.

Each station recorded beta levels less than .005 m/rem an hour.

**Distribution:**

EPA	DOE
NRC	Mat-Ed
PEMA	CAC
Newsroom	

COMMONWEALTH OF PENNSYLVANIA  
DEPARTMENT OF ENVIRONMENTAL RESOURCES  
HARRISBURG, PENNSYLVANIA

PRESS RELEASE  
Newsroom  
Contact: Amy Kelchner  
Telephone 717-787-2163

FOR IMMEDIATE RELEASE

HARRISBURG -- Following are the results of the Community Monitoring program for May 30, 31 and June 1, 1980.

All readings were within the range of natural background levels for the sampling days May 30, 31 and June 1, 1980. A more detailed summary of the results is attached.

The following information is provided to help the reader understand the data.

Radiation is a form of energy. It comes from natural sources such as the sun, rocks and other minerals in the form of rays or fast-moving particles. The most common types of natural radiation are gamma-rays and alpha and beta particles. X-rays used by physicians and dentists are an example of man-made radiation.

Gamma-rays are similar to light rays except the gamma-ray energies are 100,000 to 1,000,000 times as great. Alpha particles are fast-moving helium atom nuclei. Beta particles are fast-moving electrons that have been ejected by a decaying atom.

These rays or particles can penetrate the body depositing their energy in the body cells. The amount of radiation absorbed by the body is measured in millirem. The rate at which the radiation is absorbed is measured in millirem/hour (mrem/hr). The term millirem takes into account the type of radiation, the intensity of radiation, and its biological effect.

Not all radiation interacts with the body in the same manner. Gamma radiation is highly penetrating. The result is it can be absorbed anywhere in the body. By comparison, beta radiation is short range and can only penetrate a short distance into the skin.

A person is exposed to a variety of natural radiation sources regardless of where he lives. These sources include cosmic rays, the uranium and thorium occurring naturally in rocks and minerals, and the radioactive potassium and carbon found normally in the human body. Each year a person in south central Pennsylvania absorbs, on the average, about 80 to 100 mrem per year or .009 to .012 mrem/hr from natural sources. Other locations in the United States have dose rates as much as twice these levels.

-more-

GAMMA RATE RECORDERS (LSI)

Gamma rate recorders (LSI) are used to measure gamma radiation levels at the monitoring site. The recorders are sensitive enough to measure radiation from naturally-occurring radiation sources. The following table summarizes the measurements made for each monitoring location. The data were reported on May 30, 1980. The results are shown in millirem/hour (mrem/hr).

<u>Location</u>	<u>Average (mrem/hr)</u>	<u>Comment</u>
Fairview	0.009	Normal Background
Newberrytown	0.008	Normal Background
Goldsboro	0.014	Normal Background
York Haven	Data to EPA	
East Manchester	No Instrument	
Lower Swatara	0.007	Normal Background
Middletown	0.010	Normal Background
Royalton	0.016	Normal Background
Londonderry	Data to EPA	
Conoy	No Data Available	
West Donegal	0.009	Normal Background
Elizabethtown	No Instrument	

BETA RATE RECORDERS (LUDLUM)

Beta rate recorders (Ludlum) are used to measure beta and gamma radiation levels at the monitoring site. The recorders are sensitive enough to measure radiation from naturally-occurring radiation sources.

Each station recorded beta levels less than .005 m/rem an hour.

Distribution:

EPA	DOE
NRC	Met-EJ
PEMA	GAC
Newsroom	

### GAMMA RATE RECORDERS (LSI)

Gamma rate recorders (LSI) are used to measure gamma radiation levels at the monitoring site. The recorders are sensitive enough to measure radiation from naturally-occurring radiation sources. The following table summarizes the measurements made for each monitoring location. The data were reported on June 1, 1980. The results are shown in millirem/hour (mrem/hr).

<u>Location</u>	<u>Average (mrem/hr)</u>	<u>Comment</u>
Fairview	0.009	Normal Background
Newberrytown	No Data Available	
Goldsboro	0.014	Normal Background
York Haven	Data to EPA	
East Manchester	No Instrument	
Lower Swatara	0.007	Normal Background
Middletown	Instrument Failure	
Royalton	0.016	Normal Background
Londonderry	Data to EPA	
Conoy	No Data Available	
West Donegal	0.009	Normal Background
Elizabethtown	No Instrument	

### BETA RATE RECORDERS (LUDLUM)

Beta rate recorders (Ludlum) are used to measure beta and gamma radiation levels at the monitoring site. The recorders are sensitive enough to measure radiation from naturally-occurring radiation sources.

Each station recorded beta levels less than .005 m/rem an hour.

**Distribution:**

EPA	DOE
NRC	Met-Ed
PEMA	GAC
Newsroom	

### GAMMA RATE RECORDERS (LSI)

Gamma rate recorders (LSI) are used to measure gamma radiation levels at the monitoring site. The recorders are sensitive enough to measure radiation from naturally-occurring radiation sources. The following table summarizes the measurements made for each monitoring location. The data were reported on May 31, 1980. The results are shown in millirem/hour (mrem/hr).

<u>Location</u>	<u>Average (mrem/hr)</u>	<u>Comment</u>
Fairview	0.009	Normal Background
Newberrytown	0.008	Normal Background
Goldsboro	0.013	Normal Background
York Haven	Data to EPA	
East Manchester	No Instrument	
Lower Swatara	0.007	Normal Background
Middletown	0.010	Normal Background
Royalton	0.015	Normal Background
Londonderry	Data to EPA	
Conoy	No Data Available	
West Donegal	0.009	Normal Background
Elizabethtown	No Instrument	

### BETA RATE RECORDERS (LUDLUM)

Beta rate recorders (Ludlum) are used to measure beta and gamma radiation levels at the monitoring site. The recorders are sensitive enough to measure radiation from naturally-occurring radiation sources.

Each station recorded beta levels less than .005 m/rem an hour.

#### Distribution:

EPA	DOE
NRC	Met-Ed
PEMA	GAC
Newsroom	

COMMONWEALTH OF PENNSYLVANIA  
DEPARTMENT OF ENVIRONMENTAL RESOURCES  
HARRISBURG, PENNSYLVANIA

PRESS RELEASE  
Newsroom  
Contact: Amy Kelchner  
Telephone 717-787-2163  
June 4, 1980

FOR IMMEDIATE RELEASE

HARRISBURG -- Following are the results of the Community Monitoring Program for June 2, 1980.

All readings were within the range of natural background levels for the sampling day ending June 2, 1980.  
A more detailed summary of the results is attached.

### GAMMA RATE RECORDERS (LSI)

Gamma rate recorders (LSI) are used to measure gamma radiation levels at the monitoring site. The recorders are sensitive enough to measure radiation from naturally-occurring radiation sources. The following table summarizes the measurements made for each monitoring location. The data were reported on June 2, 1980. The results are shown in millirem/hour (mrem/hr).

<u>Location</u>	<u>Average (mrem/hr)</u>	<u>Comment</u>
Fairview	0.009	Normal Background
Newberrytown	0.008	Normal Background
Goldsboro	0.014	Normal Background
York Haven	Data to EPA	
East Manchester	No Data Available	
Lower Swatara	0.007	Normal Background
Middletown	0.009	Normal Background
Royalton	0.016	Normal Background
Londonderry	Data to EPA	
Conoy	Data to EPA	
West Donegal	0.009	Normal Background
Elizabethtown	No Instrument	

### BETA RATE RECORDERS (LUDLUM)

Beta rate recorders (Ludlum) are used to measure beta and gamma radiation levels at the monitoring site. The recorders are sensitive enough to measure radiation from naturally-occurring radiation sources.

Each station recorded beta levels less than .005 m/rem an hour.

**Distribution:**

EPA	DOE
NRC	Met-Ed
PEMA	GAC
Newsroom	



COMMONWEALTH OF PENNSYLVANIA  
DEPARTMENT OF ENVIRONMENTAL RESOURCES  
HARRISBURG, PENNSYLVANIA

PRESS RELEASE  
Newsroom  
Contact: Amy Kelchner  
Telephone 717-797-2163  
June 4, 1980

FOR IMMEDIATE RELEASE

HARRISBURG -- Following are the results of the Community Monitoring Program for June 3, 1980.

All readings were within the range of natural background

levels for the sampling day ending June 3, 1980.

A more detailed summary of the results is attached.

### GAMMA RATE RECORDERS (LSI)

Gamma rate recorders (LSI) are used to measure gamma radiation levels at the monitoring site. The recorders are sensitive enough to measure radiation from naturally-occurring radiation sources. The following table summarizes the measurements made for each monitoring location. The data were reported on June 3, 1980. The results are shown in millirem/hour (mrem/hr).

<u>Location</u>	<u>Average (mrem/hr)</u>	<u>Comment</u>
Fairview	0.009	Normal Background
Newberrytown	0.008	Normal Background
Goldsboro	0.013	Normal Background
York Haven	Data to EPA	
East Manchester	No Instrument	
Lower Swatara	0.008	Normal Background
Middletown	0.009	Normal Background
Royalton	0.016	Normal Background
Londonderry	Data to EPA	
Conoy	0.014	Normal Background
West Donegal	0.009	Normal Background
Elizabethtown	No Instrument	

### BETA RATE RECORDERS (LUDLUM)

Beta rate recorders (Ludlum) are used to measure beta and gamma radiation levels at the monitoring site. The recorders are sensitive enough to measure radiation from naturally-occurring radiation sources.

Each station recorded beta levels less than .005 m/rem an hour.

**Distribution:**

EPA	DOE
NRC	Met-Ed
PEMA	GAC
Newsroom	

COMMONWEALTH OF PENNSYLVANIA  
DEPARTMENT OF ENVIRONMENTAL RESOURCES  
HARRISBURG, PENNSYLVANIA

PRESS RELEASE  
Newsroom  
Contact: Amy Kelchner  
Telephone 717-787-2163  
June 5, 1980

FOR IMMEDIATE RELEASE

HARRISBURG -- Following are the results of the Community Monitoring Program  
for June 4, 1980:

All readings were within the range of natural background  
levels for the sampling day ending June 4, 1980.  
A more detailed summary of the results is attached.

### GAMMA RATE RECORDERS (LSI)

Gamma rate recorders (LSI) are used to measure gamma radiation levels at the monitoring site. The recorders are sensitive enough to measure radiation from naturally-occurring radiation sources. The following table summarizes the measurements made for each monitoring location. The data were reported on June 4, 1980. The results are shown in millirem/hour (mrem/hr).

<u>Location</u>	<u>Average (mrem/hr)</u>	<u>Comment</u>
Fairview	0.009	Normal Background
Newberrytown	0.008	Normal Background
Goldsboro	0.014	Normal Background
York Haven	Data to EPA	
East Manchester	No Instrument	
Lower Swatara	No Data Available	
Middletown	0.009	Normal Background
Royalton	0.016	Normal Background
Londonderry	Data to EPA	
Conoy	No Data Available	
West Donegal	0.009	Normal Background
Elizabethtown	No Instrument	

### BETA RATE RECORDERS (LUDLUM)

Beta rate recorders (Ludlum) are used to measure beta and gamma radiation levels at the monitoring site. The recorders are sensitive enough to measure radiation from naturally-occurring radiation sources.

Each station recorded beta levels less than .005 m/rem an hour.

**Distribution:**

EPA	DOE
NRC	Met-Ed
PEMA	GAC
Newsroom	

COMMONWEALTH OF PENNSYLVANIA  
DEPARTMENT OF ENVIRONMENTAL RESOURCES  
HARRISBURG, PENNSYLVANIA

PRESS RELEASE  
Newsroom  
Contact: Amy Kolchner  
Telephone 717-787-2163  
June 6, 1980

FOR IMMEDIATE RELEASE

HARRISBURG -- Following are the results of the Community Monitoring Program  
for June 5, 1980:

All readings were within the range of natural background  
levels for the sampling day ending June 5, 1980.  
A more detailed summary of the results is attached.

### GAMMA RATE RECORDERS (LSI)

Gamma rate recorders (LSI) are used to measure gamma radiation levels at the monitoring site. The recorders are sensitive enough to measure radiation from naturally-occurring radiation sources. The following table summarizes the measurements made for each monitoring location. The data were reported on June 5, 1980. The results are shown in millirem/hour (mrem/hr).

<u>Location</u>	<u>Average (mrem/hr)</u>	<u>Comment</u>
Fairview	0.009	Normal Background
Newberrytown	0.008	Normal Background
Goldsboro	0.013	Normal Background
York Haven	Data to EPA	
East Manchester	No Instrument	
Lower Swatara	0.007	Normal Background
Middletown	0.009	Normal Background
Royalton	0.015	Normal Background
Londonderry	Data to EPA	
Conoy	No Data Available	
West Donegal	0.009	Normal Background
Elizabethtown	No Instrument	

### BETA RATE RECORDERS (LUDLUM)

Beta rate recorders (Ludlum) are used to measure beta and gamma radiation levels at the monitoring site. The recorders are sensitive enough to measure radiation from naturally-occurring radiation sources.

Each station recorded beta levels less than .005 m/rem an hour.

**Distribution:**

EPA	DOE
NRC	Met-Ed
PEMA	GAC
Newsroom	

COMMONWEALTH OF PENNSYLVANIA  
DEPARTMENT OF ENVIRONMENTAL RESOURCES  
HARRISBURG, PENNSYLVANIA

PRESS RELEASE  
Newsroom  
Contact: Amy Kelchner  
Telephone 717-787-2163  
June 9, 1980

FOR IMMEDIATE RELEASE

HARRISBURG -- Following are the results of the Community Monitoring program for June 6, 7, and 8, 1980:

All readings were within the range of natural background levels for the sampling days June 6, 7 and 8, 1980. A more detailed summary of the results is attached.

The following information is provided to help the reader understand the data.

Radiation is a form of energy. It comes from natural sources such as the sun, rocks and other minerals in the form of rays or fast-moving particles. The most common types of natural radiation are gamma-rays and alpha and beta particles. X-rays used by physicians and dentists are an example of man-made radiation.

Gamma-rays are similar to light rays except the gamma-ray energies are 100,000 to 1,000,000 times as great. Alpha particles are fast-moving helium atom nuclei. Beta particles are fast-moving electrons that have been ejected by a decaying atom.

These rays or particles can penetrate the body depositing their energy in the body cells. The amount of radiation absorbed by the body is measured in millirem. The rate at which the radiation is absorbed is measured in millirem/hour (mrem/hr). The term millirem takes into account the type of radiation, the intensity of radiation, and its biological effect.

Not all radiation interacts with the body in the same manner. Gamma radiation is highly penetrating. The result is it can be absorbed anywhere in the body. By comparison, beta radiation is short range and can only penetrate a short distance into the skin.

A person is exposed to a variety of natural radiation sources regardless of where he lives. These sources include cosmic rays, the uranium and thorium occurring naturally in rocks and minerals, and the radioactive potassium and carbon found normally in the human body. Each year a person in south central Pennsylvania absorbs, on the average, about 30 to 100 mrem per year or .009 to .012 mrem/hr from natural sources. Other locations in the United States have dose rates as much as twice these levels.

-more-

### GAMMA RATE RECORDERS (LSI)

Gamma rate recorders (LSI) are used to measure gamma radiation levels at the monitoring site. The recorders are sensitive enough to measure radiation from naturally-occurring radiation sources. The following table summarizes the measurements made for each monitoring location. The data were reported on June 8, 1980. The results are shown in millirem/hour (mrem/hr).

<u>Location</u>	<u>Average (mrem/hr)</u>	<u>Comment</u>
Fairview	0.009	Normal Background
Newberrytown	0.008	Normal Background
Goldsboro	0.013	Normal Background
York Haven	Data to EPA	
East Manchester	0.015	Normal Background
Lower Swatara	0.007	Normal Background
Middletown	0.009	Normal Background
Royalton	0.017	Normal Background
Londonderry	Data to EPA	
Conoy	No Data Available	
West Donegal	0.009	Normal Background
Elizabethtown	No Instrument	

### BETA RATE RECORDERS (LUDLUM)

Beta rate recorders (Ludlum) are used to measure beta and gamma radiation levels at the monitoring site. The recorders are sensitive enough to measure radiation from naturally-occurring radiation sources.

Each station recorded beta levels less than .005 m/rem an hour.

**Distribution:**

EPA	DOE
NERC	Met-Ed
PEMA	GAC
Newsroom	



### GAMMA RATE RECORDERS (LSI)

Gamma rate recorders (LSI) are used to measure gamma radiation levels at the monitoring site. The recorders are sensitive enough to measure radiation from naturally-occurring radiation sources. The following table summarizes the measurements made for each monitoring location. The data were reported on June 7, 1980. The results are shown in millirem/hour (mrem/hr).

<u>Location</u>	<u>Average (mrem/hr)</u>	<u>Comment</u>
Fairview	0.009	Normal Background
Newberrytown	0.008	Normal Background
Goldsboro	0.013	Normal Background
York Haven	Data to EPA	
East Manchester	0.015	Normal Background
Lower Swatara	0.007	Normal Background
Middletown	0.009	Normal Background
Royalton	0.017	Normal Background
Londonderry	Data to EPA	
Conoy	No Data Available	
West Donegal	0.009	Normal Background
Elizabethtown	No Instrument	

### BETA RATE RECORDERS (LUDLUM)

Beta rate recorders (Ludlum) are used to measure beta and gamma radiation levels at the monitoring site. The recorders are sensitive enough to measure radiation from naturally-occurring radiation sources.

Each station recorded beta levels less than .005 m/rem an hour.

**Distribution:**

EPA	DOE
NRC	Met-Ed
FEMA	GAC
Newsroom	

GAMMA RATE RECORDERS (LSI)

Gamma rate recorders (LSI) are used to measure gamma radiation levels at the monitoring site. The recorders are sensitive enough to measure radiation from naturally-occurring radiation sources. The following table summarizes the measurements made for each monitoring location. The data were reported on June 6, 1980. The results are shown in millirem/hour (mrem/hr).

<u>Location</u>	<u>Average (mrem/hr)</u>	<u>Comment</u>
Fairview	0.009	Normal Background
Newberrytown	0.007	Normal Background
Goldsboro	0.013	Normal Background
York Haven	Data to EPA	
East Manchester	No Instrument	
Lower Swatara	0.007	Normal Background
Middletown	0.009	Normal Background
Royalton	0.016	Normal Background
Londonderry	Data to EPA	
Concy	No Data Available	
West Donegal	0.009	Normal Background
Elizabethtown	No Instrument	

BETA RATE RECORDERS (LUDLUM)

Beta rate recorders (Ludlum) are used to measure beta and gamma radiation levels at the monitoring site. The recorders are sensitive enough to measure radiation from naturally-occurring radiation sources.

Each station recorded beta levels less than .005 m/rem an hour.

Distribution:

EPA	DOE
NRC	Met-Ed
PEMA	GAC
Newsroom	

COMMONWEALTH OF PENNSYLVANIA  
DEPARTMENT OF ENVIRONMENTAL RESOURCES  
HARRISBURG, PENNSYLVANIA

PRESS RELEASE  
Newsroom  
Contact: Amy Kelchner  
Telephone 717-787-2163  
June 10, 1980

FOR IMMEDIATE RELEASE

HARRISBURG — Following are the results of the Community Monitoring Program for June 9, 1980.

All readings were within the range of natural background levels for the sampling day ending June 9, 1980.

A more detailed summary of the results is attached.

### GAMMA RATE RECORDERS (LSI)

Gamma rate recorders (LSI) are used to measure gamma radiation levels at the monitoring site. The recorders are sensitive enough to measure radiation from naturally-occurring radiation sources. The following table summarizes the measurements made for each monitoring location. The data were reported on June 9, 1980. The results are shown in millirem/hour (mrem/hr).

<u>Location</u>	<u>Average (mrem/hr)</u>	<u>Comment</u>
Fairview	0.009	Normal Background
Newberrytown	0.008	Normal Background
Goldsboro	0.014	Normal Background
York Raven	Data to EPA	
East Manchester	0.014	Normal Background
Lower Swatara	0.007	Normal Background
Middletown	0.010	Normal Background
Royalton	0.015	Normal Background
Londonderry	Data to EPA	
Conoy	No Data Available	
West Donegal	0.009	Normal Background
Elizabethtown	No Instrument	

### BETA RATE RECORDERS (LUDLUM)

Beta rate recorders (Ludlum) are used to measure beta and gamma radiation levels at the monitoring site. The recorders are sensitive enough to measure radiation from naturally-occurring radiation sources.

Each station recorded beta levels less than .005 m/rem an hour.

**Distribution:**

EPA	DOE
NRC	Met-Ed
PEMA	GAC
Newsroom	

COMMONWEALTH OF PENNSYLVANIA  
DEPARTMENT OF ENVIRONMENTAL RESOURCES  
HARRISBURG, PENNSYLVANIA

PRESS RELEASE  
Newsroom  
Contact: Amy Keichner  
Telephone 717-787-2163  
June 11, 1980

FOR IMMEDIATE RELEASE

HARRISBURG -- Following are the results of the Community Monitoring Program  
for June 10, 1980.

All readings were within the range of natural background  
levels for the sampling day ending June 10, 1980.  
A more detailed summary of the results is attached.

### GAMMA RATE RECORDERS (LSI)

Gamma rate recorders (LSI) are used to measure gamma radiation levels at the monitoring site. The recorders are sensitive enough to measure radiation from naturally-occurring radiation sources. The following table summarizes the measurements made for each monitoring location. The data were reported on June 10, 1980. The results are shown in millirem/hour (mrem/hr).

<u>Location</u>	<u>Average (mrem/hr)</u>	<u>Comment</u>
Fairview	0.009	Normal Background
Newberrytown	0.008	Normal Background
Goldsboro	0.014	Normal Background
York Haven	Data to EPA	
East Manchester	0.014	Normal Background
Lower Swatara	0.007	Normal Background
Middletown	0.009	Normal Background
Royalton	0.015	Normal Background
Londonderry	Data to EPA	
Conoy	0.014	Normal Background
West Donegal	0.009	Normal Background
Elizabethtown	No Data Available	

### BETA RATE RECORDERS (LUDLUM)

Beta rate recorders (Ludlum) are used to measure beta and gamma radiation levels at the monitoring site. The recorders are sensitive enough to measure radiation from naturally-occurring radiation sources.

Each station recorded beta levels less than .005 m/rem an hour.

**Distribution:**

EPA	DOE
NRC	Met-Ed
PEMA	GAC
Newsroom	

### GAMMA RATE RECORDERS (LSI)

Gamma rate recorders (LSI) are used to measure gamma radiation levels at the monitoring site. The recorders are sensitive enough to measure radiation from naturally-occurring radiation sources. The following table summarizes the measurements made for each monitoring location. The data were reported on June 11, 1980. The results are shown in millirem/hour (mrem/hr).

<u>Location</u>	<u>Average (mrem/hr)</u>	<u>Comment</u>
Fairview	0.009	Normal Background
Newberrytown	0.008	Normal Background
Goldsboro	0.014	Normal Background
York Haven	Data to EPA	
East Manchester	0.015	Normal Background
Lower Swatara	0.007	Normal Background
Middletown	0.009	Normal Background
Royalton	0.015	Normal Background
Londonderry	Data to EPA	
Conoy	0.011	Normal Background
West Donegal	0.009	Normal Background
Elizabethtown	No Data Available	

### BETA RATE RECORDERS (LUDLUM)

Beta rate recorders (Ludlum) are used to measure beta and gamma radiation levels at the monitoring site. The recorders are sensitive enough to measure radiation from naturally-occurring radiation sources.

Each station recorded beta levels less than .005 m/rem an hour.

**Distribution:**

EPA	DOE
NRC	Met-Ed
PEMA	GAC
Newsroom	

GAMMA RATE RECORDERS (LSI)

Gamma rate recorders (LSI) are used to measure gamma radiation levels at the monitoring site. The recorders are sensitive enough to measure radiation from naturally-occurring radiation sources. The following table summarizes the measurements made for each monitoring location. The data were reported on June 12, 1980. The results are shown in millirem/hour (mrem/hr).

<u>Location</u>	<u>Average (mrem/hr)</u>	<u>Comment</u>
Fairview	0.009	Normal Background
Newberrytown	0.008	Normal Background
Goldsboro	0.013	Normal Background
York Haven	Data to EPA	
East Manchester	0.014	Normal Background
Lower Swatara	0.007	Normal Background
Middletown	0.009	Normal Background
Royalton	0.016	Normal Background
Londonderry	Data to EPA	
Conoy	0.013	Normal Background
West Donegal	0.009	Normal Background
Elizabethtown	Instrument Failure	

BETA RATE RECORDERS (LUDLUM)

Beta rate recorders (Ludlum) are used to measure beta and gamma radiation levels at the monitoring site. The recorders are sensitive enough to measure radiation from naturally-occurring radiation sources.

Each station recorded beta levels less than .005 m/rem an hour.

Distribution:

EPA	DOE
NRC	Met-Ed
PEMA	GAC
Newsroom	



### GAMMA RATE RECORDERS (LSI)

Gamma rate recorders (LSI) are used to measure gamma radiation levels at the monitoring site. The recorders are sensitive enough to measure radiation from naturally-occurring radiation sources. The following table summarizes the measurements made for each monitoring location. The data were reported on June 13, 1980. The results are shown in millirem/hour (mrem/hr).

<u>Location</u>	<u>Average (mrem/hr)</u>	<u>Comment</u>
Fairview	0.010	Normal Background
Newberrytown	0.008	Normal Background
Goldsboro	0.014	Normal Background
York Haven	Data to EPA	
East Manchester	0.015	Normal Background
Lower Swatara	0.007	Normal Background
Middletown	0.009	Normal Background
Royalton	0.016	Normal Background
Londonderry	Data to EPA	
Conoy	0.013	Normal Background
West Donegal	0.009	Normal Background
Elizabethtown	Instrument Failure	

### BETA RATE RECORDERS (LUDLUM)

Beta rate recorders (Ludlum) are used to measure beta and gamma radiation levels at the monitoring site. The recorders are sensitive enough to measure radiation from naturally-occurring radiation sources.

Each station recorded beta levels less than .005 m/rem an hour.

Distribution:

EPA	DOE
NRC	Met-Ed
PENNA	GAC
Newsroom	

### GAMMA RATE RECORDERS (LSI)

Gamma rate recorders (LSI) are used to measure gamma radiation levels at the monitoring site. The recorders are sensitive enough to measure radiation from naturally-occurring radiation sources. The following table summarizes the measurements made for each monitoring location. The data were reported on June 14, 1980. The results are shown in millirem/hour (mrem/hr).

<u>Location</u>	<u>Average (mrem/hr)</u>	<u>Comment</u>
Fairview	0.009	Normal Background
Newberrytown	0.008	Normal Background
Goldsboro	0.014	Normal Background
York Haven	Data to EPA	
East Manchester	0.015	Normal Background
Lower Swatara	0.007	Normal Background
Middletown	0.009	Normal Background
Royalton	0.017	Normal Background
Londonderry	Data to EPA	
Conoy	0.013	Normal Background
West Donegal	0.009	Normal Background
Elizabethtown	Instrument Failure	

### BETA RATE RECORDERS (LUDLUM)

Beta rate recorders (Ludlum) are used to measure beta and gamma radiation levels at the monitoring site. The recorders are sensitive enough to measure radiation from naturally-occurring radiation sources.

Each station recorded beta levels less than .005 m/rem an hour.

**Distribution:**

EPA	DOE
NRC	Met-Ed
PEMA	GAC
Newsroom	

### GAMMA RATE RECORDERS (LSI)

Gamma rate recorders (LSI) are used to measure gamma radiation levels at the monitoring site. The recorders are sensitive enough to measure radiation from naturally-occurring radiation sources. The following table summarizes the measurements made for each monitoring location. The data were reported on June 15, 1980. The results are shown in millirem/hour (mrem/hr).

<u>Location</u>	<u>Average (mrem/hr)</u>	<u>Comment</u>
Fairview	0.009	Normal Background
Newberrytown	0.009	Normal Background
Goldsboro	0.014	Normal Background
York Haven	Data to EPA	
East Manchester	0.015	Normal Background
Lower Swatara	0.007	Normal Background
Middletown	0.009	Normal Background
Royalton	0.016	Normal Background
Londonderry	Data to EPA	
Conoy	0.013	Normal Background
West Donegal	0.009	Normal Background
Elizabethtown	Instrument Failure	

### BETA RATE RECORDERS (LUDLUM)

Beta rate recorders (Ludlum) are used to measure beta and gamma radiation levels at the monitoring site. The recorders are sensitive enough to measure radiation from naturally-occurring radiation sources.

Each station recorded beta levels less than .005 m/rem an hour.

**Distribution:**

EPA	DOE
NRC	Met-Ed
PEMA	GAC
Newsroom	

### GAMMA RATE RECORDERS (LSI)

Gamma rate recorders (LSI) are used to measure gamma radiation levels at the monitoring site. The recorders are sensitive enough to measure radiation from naturally-occurring radiation sources. The following table summarizes the measurements made for each monitoring location. The data were reported on June 16, 1980. The results are shown in millirem/hour (mrem/hr).

<u>Location</u>	<u>Average (mrem/hr)</u>	<u>Comment</u>
Fairview	0.010	Normal Background
Newberrytown	0.008	Normal Background
Goldsboro	0.014	Normal Background
York Haven	Data to EPA	
East Manchester	Instrument Failure	
Lower Swatara	0.007	Normal Background
Middletown	0.009	Normal Background
Royalton	0.017	Normal Background
Londonderry	Data to EPA	
Conoy	0.013	Normal Background
West Donegal	0.009	Normal Background
Elizabethtown	Instrument Failure	

### BETA RATE RECORDERS (LUDLUM)

Beta rate recorders (Ludlum) are used to measure beta and gamma radiation levels at the monitoring site. The recorders are sensitive enough to measure radiation from naturally-occurring radiation sources.

Each station recorded beta levels less than .005 m/rem an hour.

Distribution:

EPA	DOE
NRC	Met-Ed
PEMA	GAC
Newsroom	

GAMMA RATE RECORDERS (LSI)

Gamma rate recorders (LSI) are used to measure gamma radiation levels at the monitoring site. The recorders are sensitive enough to measure radiation from naturally-occurring radiation sources. The following table summarizes the measurements made for each monitoring location. The data were reported on June 17, 1980. The results are shown in millirem/hour (mrem/hr).

<u>Location</u>	<u>Average (mrem/hr)</u>	<u>Comment</u>
Fairview	0.010	Normal Background
Newberrytown	0.008	Normal Background
Goldsboro	0.014	Normal Background
York Haven	Data to EPA	
East Manchester	No Data Available	
Lower Swatara	0.007	Normal Background
Middletown	0.009	Normal Background
Royalton	0.017	Normal Background
Londonderry	Data to EPA	
Conoy	0.012	Normal Background
West Donegal	0.009	Normal Background
Elizabethtown	Instrument Failure	

BETA RATE RECORDERS (LUDLUM)

Beta rate recorders (Ludlum) are used to measure beta and gamma radiation levels at the monitoring site. The recorders are sensitive enough to measure radiation from naturally-occurring radiation sources.

Each station recorded beta levels less than .005 m/rem an hour.

Distribution:

EPA	DOE
NRC	Met-Ed
PEMA	GAC
Newsroom	

### GAMMA RATE RECORDERS (LSI)

Gamma rate recorders (LSI) are used to measure gamma radiation levels at the monitoring site. The recorders are sensitive enough to measure radiation from naturally-occurring radiation sources. The following table summarizes the measurements made for each monitoring location. The data were reported on June 18, 1980. The results are shown in millirem/hour (mrem/hr).

<u>Location</u>	<u>Average (mrem/hr)</u>	<u>Comment</u>
Fairview	0.009	Normal Background
Newberrytown	0.008	Normal Background
Goldsboro	0.013	Normal Background
York Haven	Data to EPA	
East Manchester	0.013	Normal Background
Lower Swatara	0.007	Normal Background
Middletown	0.009	Normal Background
Royalton	Instrument Failure	
Londonderry	Data to EPA	
Conoy	Instrument Failure	
West Donegal	0.009	Normal Background
Elizabethtown	No Instrument	

### BETA RATE RECORDERS (LUDLUM)

Beta rate recorders (Ludlum) are used to measure beta and gamma radiation levels at the monitoring site. The recorders are sensitive enough to measure radiation from naturally-occurring radiation sources.

Each station recorded beta levels less than .005 m/rem an hour.

**Distribution:**

EPA	DOE
NRC	Met-Ed
PEMA	GAC
Newsroom	

### GAMMA RATE RECORDERS (LSI)

Gamma rate recorders (LSI) are used to measure gamma radiation levels at the monitoring site. The recorders are sensitive enough to measure radiation from naturally-occurring radiation sources. The following table summarizes the measurements made for each monitoring location. The data were reported on June 20, 1980. The results are shown in millirem/hour (mrem/hr).

<u>Location</u>	<u>Average (mrem/hr)</u>	<u>Comment</u>
Fairview	No Data Available	
Newberrytown	0.008	Normal Background
Goldsboro	0.014	Normal Background
York Haven	Data to EPA	
East Manchester	0.014	Normal Background
Lower Swatara	0.007	Normal Background
Middletown	0.010	Normal Background
Royalton	0.016	Normal Background
Londonderry	Data to EPA	
Conoy	0.011	Normal Background
West Donegal	0.009	Normal Background
Elizabethtown	0.008	Normal Background

### BETA RATE RECORDERS (LUDLUM)

Beta rate recorders (Ludlum) are used to measure beta and gamma radiation levels at the monitoring site. The recorders are sensitive enough to measure radiation from naturally-occurring radiation sources.

Each station recorded beta levels less than .005 m/rem an hour.

**Distribution:**

EPA	DOE
NRC	Met-Ed
PEMA	GAC
Newsroom	

GAMMA RATE RECORDERS (LSI)

Gamma rate recorders (LSI) are used to measure gamma radiation levels at the monitoring site. The recorders are sensitive enough to measure radiation from naturally-occurring radiation sources. The following table summarizes the measurements made for each monitoring location. The data were reported on June 21, 1980. The results are shown in millirem/hour (mrem/hr).

<u>Location</u>	<u>Average (mrem/hr)</u>	<u>Comment</u>
Fairview	0.009	Normal Background
Newberrytown	0.008	Normal Background
Goldsboro	0.014	Normal Background
York Haven	Data to EPA	
East Manchester	0.013	Normal Background
Lower Swatara	0.008	Normal Background
Middletown	0.009	Normal Background
Royalton	0.016	Normal Background
Londonderry	Data to EPA	
Jonoy	0.013	Normal Background
West Donegal	0.015	Normal Background
Elizabethtown	0.008	Normal Background

BETA RATE RECORDERS (LUDLUM)

Beta rate recorders (Ludlum) are used to measure beta and gamma radiation levels at the monitoring site. The recorders are sensitive enough to measure radiation from naturally-occurring radiation sources.

Each station recorded beta levels less than .005 m/rem an hour.

Distribution:

EPA	DOE
NRC	Met-Ed
PEMA	GAC
Newsroom	



### GAMMA RATE RECORDERS (LSI)

Gamma rate recorders (LSI) are used to measure gamma radiation levels at the monitoring site. The recorders are sensitive enough to measure radiation from naturally-occurring radiation sources. The following table summarizes the measurements made for each monitoring location. The data were reported on July 1, 1980. The results are shown in millirem/hour (mrem/hr).

<u>Location</u>	<u>Average (mrem/hr)</u>	<u>Comment</u>
Fairview	0.010.	Normal Background
Newberrytown	No report from Community Monitor	
Goldsboro	No report from Community Monitor	
York Haven	Data to EPA	
East Manchester	0.012	Normal Background
Lower Swatara	0.008	Normal Background
Middletown	0.009	Normal Background
Royalton	0.016	Normal Background
Londonderry	Data to EPA	
Conoy	0.013	Normal Background
West Donegal	Instrument Failure	
Elizabethtown	Instrument Failure	

### BETA RATE RECORDERS (LUDLUM)

Beta rate recorders (Ludlum) are used to measure beta and gamma radiation levels at the monitoring site. The recorders are sensitive enough to measure radiation from naturally-occurring radiation sources.

Each station recorded beta levels less than .005 m/rem an hour.

A slight trace of Kr-85 was reported at Royalton's Station for a 10 minute period, however, it was less than the daily reported level of .005 millirem.

**Distribution:**

EPA	DOE
NRC	Met-Ed
PEMA	GAC
Newsroom	

GAMMA RATE RECORDERS (LSI)

Gamma rate recorders (LSI) are used to measure gamma radiation levels at the monitoring site. The recorders are sensitive enough to measure radiation from naturally-occurring radiation sources. The following table summarizes the measurements made for each monitoring location. The data were reported on June 22, 1980. The results are shown in millirem/hour (mrem/hr).

<u>Location</u>	<u>Average (mrem/hr)</u>	<u>Comment</u>
Fairview	0.009	Normal Background
Newberrytown	0.008	Normal Background
Goldsboro	0.014	Normal Background
York Haven	Data to EPA	
East Manchester	0.015	Normal Background
Lower Swatars	0.008	Normal Background
Middletown	0.009	Normal Background
Royalton	0.017	Normal Background
Londonderry	Data to EPA	
Conoy	0.013	Normal Background
West Donegal	0.015	Normal Background
Elizabethtown	0.008	Normal Background

BETA RATE RECORDERS (LUDLUM)

Beta rate recorders (Ludlum) are used to measure beta and gamma radiation levels at the monitoring site. The recorders are sensitive enough to measure radiation from naturally-occurring radiation sources.

Each station recorded beta levels less than .005 m/rem an hour.

Distribution:

EPA	DOE
NRC	Met-Ed
PEMA	GAC
Newsroom	

COMMONWEALTH OF PENNSYLVANIA  
DEPARTMENT OF ENVIRONMENTAL RESOURCES  
HARRISBURG, PENNSYLVANIA

PRESS RELEASE  
Newsroom  
Contact: Amy Kelchner  
Telephone 717-787-2163

FOR IMMEDIATE RELEASE

HARRISBURG -- Following are the results of the Community Monitoring program  
for :

All readings were within the range of natural background  
levels for the sampling day ending . A more  
detailed summary of the results is attached.

The following information is provided to help the reader understand the data.

Radiation is a form of energy. It comes from natural sources such as the sun, rocks and other minerals in the form of rays or fast-moving particles. The most common types of natural radiation are gamma-rays and alpha and beta particles. X-rays used by physicians and dentists are an example of man-made radiation.

Gamma-rays are similar to light rays except the gamma-ray energies are 100,000 to 1,000,000 times as great. Alpha particles are fast-moving helium atom nuclei. Beta particles are fast-moving electrons that have been ejected by a decaying atom.

These rays or particles can penetrate the body depositing their energy in the body cells. The amount of radiation absorbed by the body is measured in millirem. The rate at which the radiation is absorbed is measured in millirem/hour (mrem/hr). The term millirem takes into account the type of radiation, the intensity of radiation, and its biological effect.

Not all radiation interacts with the body in the same manner. Gamma radiation is highly penetrating. The result is it can be absorbed anywhere in the body. By comparison, beta radiation is short range and can only penetrate a short distance into the skin.

A person is exposed to a variety of natural radiation sources regardless of where he lives. These sources include cosmic rays, the uranium and thorium occurring naturally in rocks and minerals, and the radioactive potassium and carbon found normally in the human body. Each year a person in south central Pennsylvania absorbs, on the average, about 80 to 100 mrem per year or .009 to .012 mrem/hr from natural sources. Other locations in the United States have dose rates as much as twice these levels.

-more-

### GAMMA RATE RECORDERS (LSI)

Gamma rate recorders (LSI) are used to measure gamma radiation levels at the monitoring site. The recorders are sensitive enough to measure radiation from naturally-occurring radiation sources. The following table summarizes the measurements made for each monitoring location. The data were reported on June 19, 1980. The results are shown in millirem/hour (mrem/hr).

<u>Location</u>	<u>Average (mrem/hr)</u>	<u>Comment</u>
Fairview	0.009	Normal Background
Newberrytown	0.008	Normal Background
Goldsboro	0.014	Normal Background
York Haven	Data to EPA	
East Manchester	0.014	Normal Background
Lower Swatara	0.007	Normal Background
Middletown	0.010	Normal Background
Royalton	Instrument Failure	
Londonderry	Data to EPA	
Conoy	0.012	Normal Background
West Donegal	0.009	Normal Background
Elizabethtown	No Data Available	

### BETA RATE RECORDERS (LUDLUM)

Beta rate recorders (Ludlum) are used to measure beta and gamma radiation levels at the monitoring site. The recorders are sensitive enough to measure radiation from naturally-occurring radiation sources.

Each station recorded beta levels less than .005 m/rem an hour.

**Distribution:**

EPA	DOE
NRC	Met-Ed
PEMA	GAC
Newsroom	

### GAMMA RATE RECORDERS (LSI)

Gamma rate recorders (LSI) are used to measure gamma radiation levels at the monitoring site. The recorders are sensitive enough to measure radiation from naturally-occurring radiation sources. The following table summarizes the measurements made for each monitoring location. The data were reported on June 30, 1980. The results are shown in millirem/hour (mrem/hr).

<u>Location</u>	<u>Average (mrem/hr)</u>	<u>Comment</u>
Fairview	0.010	Normal Background
Newberrytown	0.008	Normal Background
Goldsboro	0.014	Normal Background
York Haven	Data to EPA	
East Manchester	0.012	Normal Background
Lower Swatara	0.007	Normal Background
Middletown	0.010	Normal Background
Royalton	0.016	Normal Background
Londonderry	Data to EPA	
Conoy	0.011	Normal Background
West Donegal	0.015	Normal Background
Elizabethtown	0.008	Normal Background

### BETA RATE RECORDERS (LUDLUM)

Beta rate recorders (Ludlum) are used to measure beta and gamma radiation levels at the monitoring site. The recorders are sensitive enough to measure radiation from naturally-occurring radiation sources.

11 stations recorded beta levels less than .005 m/rem an hour.

Royalton's station recorded beta levels of 30 counts per minute (cpm) above normal background for a one hour period. This is equivalent to a beta skin dose of .017 millirem.

**Distribution:**

EPA	DOE
NRC	Met-Ed
PEMA	GAC
Newsroom	

### GAMMA RATE RECORDERS (LSI)

Gamma rate recorders (LSI) are used to measure gamma radiation levels at the monitoring site. The recorders are sensitive enough to measure radiation from naturally-occurring radiation sources. The following table summarizes the measurements made for each monitoring location. The data were reported on June 29, 1980. The results are shown in millirem/hour (mrem/hr).

<u>Location</u>	<u>Average (mrem/hr)</u>	<u>Comment</u>
Fairview	0.010	Normal Background
Newberrytown	0.008	Normal Background
Goldsboro	0.014	Normal Background
York Haven	Data to EPA	
East Manchester	0.010	Normal Background
Lower Swatara	0.008	Normal Background
Middletown	0.010	Normal Background
Royalton	0.016	Normal Background
Londonderry	Data to EPA	
Conoy	0.013	Normal Background
West Donegal	0.015	Normal Background
Elizabethtown	0.008	Normal Background

### BETA RATE RECORDERS (LUDLUM)

Beta rate recorders (Ludlum) are used to measure beta and gamma radiation levels at the monitoring site. The recorders are sensitive enough to measure radiation from naturally-occurring radiation sources.

Each station recorded beta levels less than .005 m/rem an hour.

**Distribution:**

EPA	DOE
NRC	Met-Ed
PEMA	GAC
Newsroom	

### GAMMA RATE RECORDERS (LSI)

Gamma rate recorders (LSI) are used to measure gamma radiation levels at the monitoring site. The recorders are sensitive enough to measure radiation from naturally-occurring radiation sources. The following table summarizes the measurements made for each monitoring location. The data were reported on June 28, 1980. The results are shown in millirem/hour (mrem/hr).

<u>Location</u>	<u>Average (mrem/hr)</u>	<u>Comment</u>
Fairview	0.009	Normal Background
Newberrytown	0.008	Normal Background
Goldsboro	0.014	Normal Background
York Haven	Data to EPA	
East Manchester	0.010	Normal Background
Lower Swatara	0.008	Normal Background
Middletown	0.010	Normal Background
Royalton	No report from Community Monitor	
Londonderry	Data to EPA	
Conoy	No report from Community Monitor	
West Donegal	0.015	Normal Background
Elizabethtown	0.008	Normal Background

### BETA RATE RECORDERS (LUDLUM)

Beta rate recorders (Ludlum) are used to measure beta and gamma radiation levels at the monitoring site. The recorders are sensitive enough to measure radiation from naturally-occurring radiation sources.

Each station recorded beta levels less than .005 m/rem an hour.

**Distribution:**

EPA	DOE
NRC	Met-Ed
PEMA	GAC
Newsroom	

GAMMA RATE RECORDERS (LSI)

Gamma rate recorders (LSI) are used to measure gamma radiation levels at the monitoring site. The recorders are sensitive enough to measure radiation from naturally-occurring radiation sources. The following table summarizes the measurements made for each monitoring location. The data were reported on June 27, 1980. The results are shown in millirem/hour (mrem/hr).

<u>Location</u>	<u>Average (mrem/hr)</u>	<u>Comment</u>
Fairview	0.010	Normal Background
Newberrytown	0.008	Normal Background
Goldsboro	0.014	Normal Background
York Haven	Data to EPA	
East Manchester	Instrument Failure	
Lower Swatara	0.008	Normal Background
Middletown	0.010	Normal Background
Royalton	0.016	Normal Background
Londonderry	Data to EPA	
Conoy	0.012	Normal Background
West Donegal	0.015	Normal Background
Elizabethtown	0.008	Normal Background

BETA RATE RECORDERS (LUDLUM)

Beta rate recorders (Ludlum) are used to measure beta and gamma radiation levels at the monitoring site. The recorders are sensitive enough to measure radiation from naturally-occurring radiation sources.

Each station recorded beta levels less than .005 m/rem an hour.

Distribution:

EPA	DOE
NRC	Met-Ed
PEMA	GAC
Newsroom	



### GAMMA RATE RECORDERS (LSI)

Gamma rate recorders (LSI) are used to measure gamma radiation levels at the monitoring site. The recorders are sensitive enough to measure radiation from naturally-occurring radiation sources. The following table summarizes the measurements made for each monitoring location. The data were reported on June 26, 1980. The results are shown in millirem/hour (mrem/hr).

<u>Location</u>	<u>Average (mrem/hr)</u>	<u>Comment</u>
Fairview	0.009	Normal Background
Newberrytown	0.008	Normal Background
Goldsboro	0.013	Normal Background
York Haven	Data to EPA	
East Manchester	Instrument Failure	
Lower Swatara	0.007	Normal Background
Middletown	0.010	Normal Background
Royalton	0.017	Normal Background
Londonderry	Data to EPA	
Conoy	No Data Available	
West Donegal	0.015	Normal Background
Elizabethtown	0.008	Normal Background

### BETA RATE RECORDERS (LUDLUM)

Beta rate recorders (Ludlum) are used to measure beta and gamma radiation levels at the monitoring site. The recorders are sensitive enough to measure radiation from naturally-occurring radiation sources.

Each station recorded beta levels less than .005 m/rem an hour.

**Distribution:**

EPA	DOE
NRC	Met-Ed
PEMA	GAC
Newsroom	

Appendix E

Monitors' Responses to

Questionnaires

What did you like best about this course?

- outstanding staff experts
- especially DER staff (Maggie especially)
- material well-organized
- experience at PSU reactor
- availability of facts & figures which may ease the anxiety of at least some of people in TMI area
- the fact that we didn't just learn to use the monitors, but much more background into
- informal atmosphere made it more comfortable
- instructors were considerate of fact that most of us were out of our league and managed to gear the course to our level
- all those connected with PSU were most tolerant and helpful throughout
- instructor, very thorough
- reading and learning about monitors
- it was objective rather than opinionated in its presentation
- hands-on experience with the monitors and excellent handouts
- learning the physical part of reading the monitors
- very straight-forward, pulled no punches
- working the units which we will be operating
- most of it - information, material - excellent; presentation good; very educational
- I now partly understand what I have been reading in "nuclearese" - abbreviations, etc., which for the most part meant nothing
- learned things I never thought I would know
- information presented by Mr. Dornsife
- the fact that I was priveleged enough to be included in it
- dedication - very sincere. I would like to see all general phases of education brought to this level of sincerity.
- regarding my own circumstance--personal disability--I received complete and sincere understanding from the very beginning of the program (totally unexpected).
- the way these professionals assumed we--the novices--would grasp the basics of the course. I believe they were rooting for us.
- all the relevant facts about radiation and their effects to myself and the community in which I live. I also liked the patience of the instructors who instructed me.
- Granlund's lecture - excellent
- all phases
- being able to feel I'll be an asset to my community in reading meters to warn of troubles. As a listener, I learned how the pro-nuclears feel.
- the opportunity to get a different scope of the situation.
- repetition - easier to comprehend
- it made me aware of factors about radiation I did not have much knowledge of before.
- the TMI explanation; how to read the instruments, and the instructors
- the instructors tried hard to instruct us on radiation
- after learning the types of radiation I was very much interested in the affects and cancer part

What did you like best about this course? (continued)

- the high quality information channeled to us, enabling us to be much better informed regarding radiation
- the machines used to monitor radiation
- instructors were great! Congenial, informative, and patient.
- the professors tried hard to make the average citizen understand the entire course. They were also cooperative.
- Labs!! Lectures, though deep, were very good.

What did you like least about this course?

- short time with Mr. Dornsife
- the time table--should have taken place sooner & shouldn't have been so rushed.
- trying to learn so much in such a short period of time--too demanding.
- too much technology discussed by some lectures. Excess of mathematics which left some persons feeling lost. Depth of some lectures caused by confusion, distress among participants.
- the class evenings were too close together. No time in between to study.
- too fast in methods
- liked it all other than the exam
- the amount of time available to work more confidently with the test equipment, especially at the PSU reactor.
- Dornsife's (DER) lecture
- the technical data thrown at us which I feel will be of no use to us. Some professors got caught up in their field and became too technical. I felt we needed more practice on the machines individually and less lecturing.
- based to protect the side of the nuclear industry. Federal people who sought out information on students. The statistical lab study we did (waste of time). Some of info and terminology was highly technical.
- sometimes one of the instructors did go over my head
- some of the instructors were using \$100 words that meant nothing at all to me.
- going too fast with information that I could not understand at all. It was like running everything together.
- getting here by 6:30 from Manchester
- not enough time spent on lab work
- the work done on standard deviations and the resultant mathematical curves. I do not feel it added to the material of the course and may, in fact, have scared some persons out of the course.
- I would have enjoyed the whole course if I would have had some background in physics
- missing trip to Penn State Reactor
- every evening for 3 hours was a bit much
- theory
- not knowing how many rems or millirems we are reading. Should have spent more time on the monitors
- not enough actual experience in the operating procedures and interpretation.
- there was no ability in the course for those who quickly understood the material to get that better, higher power information that the whole of the class could not absorb

What did you like least about this course? (continued)

- a little too drawn out and we might have been exposed to the actual instrumentation earlier in the program. I feel it would have fallen into place better when it came time to actually use the Ludlum and the LSI.
- I end up with the feeling I started in the middle of something--do not have enough basic background on the subject.
- too short to absorb
- some of the background too detailed

Other Comments

- We would like to know who is taking this course, their names, the township they represent and where they work.
- I think this course is going to be very good for the community and the people in it. Dr. Baratta and Margaret Reilly are two very good instructors. They will be very good for the course if it goes on.
- I feel I received a higher and better quality and quantity of knowledge from Dr. Baratta and Margaret Reilly than the other instructors in the class. They are what made the class as far as learning.
- You people did one hell of a good job. Thank you.
- This course was well put together and presented, given what was probably short notice. Some thought should be given to an on-going (monthly or so) course covering various topics as well as reviewing material already presented to keep it fresh.
- For me, not having any background in the course, I thought it was very interesting.
- Updates from time to time to further educate us and allow us to do the best possible job, at the same time, giving the most accurate data available.
- Excellent course, being the first of its kind. Everyone involved in preparation should be commended.
- I do not think the people will be happy knowing they are going to get the readings in rems a day later.
- Worthwhile, wish more people could take it. Feel this will be a good service to the community and wish it could extend to 10 mi. radius. Hope vandalism in the communities doesn't do the program in.
- Very good course. Should be given on other topics related to TMI.
- Follow-up meetings of this group should occur for group knowledge and exchange.
- Well-planned and presented course.
- Found speakers, Baratta, Jester and Reilly, congenial and comfortable to listen to. Also somewhat entertaining, and we needed that. Appreciated their mingling on break, acting like real people.
- There were some positive points to this course. I felt all the people involved with the teaching made 100% effort to answer questions and to be as factual as possible. There seemed to be a genuine interest in making this course a success and at making people as knowledgeable as possible.
- The instructors were impartial and did their best to take scientific data and bring it to the laymen. I felt they did not try and influence anyone's opinion whether they were anti- or pro- nuke.

#### Other Comments (continued)

- I personally feel that Margaret Reilley's honest answers to all questions reflect the need that citizens' questions should be answered regardless. I can live with the truth, but lies do create fear and strong distrust.
- When you teach this course again, take a good look at your instructors. Maggie and Tony did a fine job and seemed to be as honest as they could about data on TMI. I felt we had someone on our side. The rest could be replaced.
- Excellent.
- Thank you.
- I was very impressed with the depth of PSU's nuclear program and related staff and equipment. I think everyone in the area should have an opportunity to take this course in some form.
- Improvements should only come through the staff and participants of the program as a team effort. Most of this material presented to the general public in a proper way would definitely enlighten them, increase their confidence and improve the general sense of security.

#### Suggestions for Improvement

- Better definition of Citizen Monitoring Program before sessions started. Specifically, type and amount of equipment and time required to conduct the program.
- Have classes Monday, Wednesday, and Friday, so we could have time in between to study the material.
- In the beginning, more time should have been spent explaining the operation of the instruments before labs were started. This would have alleviated equipment misunderstanding and allowed for a more progressive lab.
- Should have a monitor that can read rems and millirems instead of counts per minute.
- There should have been an effort in screening the people who took the course to insure that people pro or con on the issue were open-minded to listen to the information given and ask intelligent questions, rather than seeming to block out what they did not want to hear.
- I don't feel working with the one digital instrument was of much value, since we won't be using it on a daily monitoring basis.