

RESULTS OF VITRIFYING FERNALD
OU-4 WASTES

DISCLAIMER

This report was prepared as an account of work sponsored by an agency of the United States Government. Neither the United States Government nor any agency thereof, nor any of their employees, makes any warranty, express or implied, or assumes any legal liability or responsibility for the accuracy, completeness, or usefulness of any information, apparatus, product, or process disclosed, or represents that its use would not infringe privately owned rights. Reference herein to any specific commercial product, process, or service by trade name, trademark, manufacturer, or otherwise does not necessarily constitute or imply its endorsement, recommendation, or favoring by the United States Government or any agency thereof. The views and opinions of authors expressed herein do not necessarily state or reflect those of the United States Government or any agency thereof.

R. A. Merrill
D. S. Janke

February 1993

RECEIVED
MAR 29 1993
OSTI

Presented at the
Waste Management '93 Symposia
February 28 - March 4, 1993
Tucson, Arizona

Prepared for
the U.S. Department of Energy
under Contract DE-AC06-76RLO 1830

Pacific Northwest Laboratory
Richland, Washington 99352

MASTER

CS

RESULTS OF VITRIFYING FERNALD OU-4 WASTES

R.A. Merrill, Battelle - Pacific Northwest Laboratory*, Richland, WA, 99352
D.S. Janke, Battelle Memorial Institute, Columbus, OH

ABSTRACT

Three silos in Operable Unit 4 (OU-4) at the Feed Materials Production Center in Fernald, Ohio, contain residues from the processing of pitchblende ores. Silos 1 and 2, designated as K-65, contain the depleted ore with a BentoGrout cap over the material to reduce radon emanation, while Silo 3 contains calcined residue from processing solutions. The residues in the three silos contain radium, uranium, uranium daughters, and heavy metals (primarily lead). Vitrification tests were carried out on various mixtures of the above materials and the resulting glasses were analyzed. The vitrified residues all tested "non-hazardous" by the Toxicity Characteristic Leachate Procedure (TCLP) and demonstrated a high degree of durability by the Product Consistency Test (PCT). The specific gravity and radon emanation of both the vitrified and non-vitrified residue were measured. Volume reductions ranging from 50 to 68 percent were obtained while the radon emanation rate was reduced by a factor of about 500,000. Radon emanation from the vitrified residue is of the same order of magnitude as emanation from natural building materials such as brick or concrete.

INTRODUCTION

The Pacific Northwest Laboratory (PNL) recently completed a series of vitrification tests on residues from the processing of uranium ore at the Feed Materials Production Center (FMPC) in Fernald, Ohio. These tests were done in support of the treatability study being conducted as part of the Remedial Investigation/Feasibility Study process currently underway at the FMPC.

The site, in a rural area in southwest Ohio, is owned by the Department of Energy (DOE) and is operated by Fernald Environmental Restoration Management Corporation (FERMCO). Three large concrete storage silos in Operable Unit 4 (OU-4) hold residues from the processing of pitchblende ores. Silos 1 and 2 contain solids (designated as K-65 material) recovered from the nitric acid digestion of pitchblende, while Silo 3 contains calcined residue from the processing solutions. A layer of bentonite clay material (BentoGrout) was recently added to the K-65 silos to reduce the radon flux from the silos. The K-65 material is a siliceous material containing uranium and thorium with high levels of radium and lead while the Silo 3 material is lower in silica and consists largely of metal oxides and salts (sulfate, phosphate, nitrate, carbonate) containing uranium, thorium, and a small amount of radium. DOE assumed ownership of the material in 1983, and thus also assumed responsibility for remediation of the silos. Remediation of the OU-4 silos focuses on addressing four major concerns:

- controlling radon release from the residues.
- preventing leakage into the aquifer immediately beneath the site.
- controlling the spread of radioactive particulate.
- controlling the gamma radiation from the residue.

Previous testing conducted at PNL demonstrated the feasibility of vitrifying the K-65 material and the effectiveness of vitrification in addressing the above stated concerns (1). The vitrified K-65 residue was extremely durable and chemically stable. Radon emanation from the vitrified residue was greatly reduced and significant reductions in waste volume were achieved. This work addressed not only the K-65 material, but also a mixture of BentoGrout and K-65 material, a mixture of K-65 and Silo 3 materials, and the Silo 3 material alone.

*Pacific Northwest Laboratory is operated by Battelle Memorial Institute for the U. S. Department of Energy under Contract DE-ACO6-76-RLO 1830.

The purpose of these tests was to demonstrate the feasibility of vitrifying the OU-4 wastes and to assess the performance of the vitrified product for comparison to alternative technologies. Specific criteria for evaluation were reduction in radon emanation, volume reduction of the waste, and durability of the product as determined by the Toxicity Characteristic Leachate Procedure (TCLP) and Product Consistency Test (PCT). In addition to analyses of the vitrified product, radon release during vitrification was also measured. Results obtained from these tests are reported and discussed below.

EXPERIMENTAL

Apparatus

The test system used to perform this work is shown in Figure 1. A test in this system consisted of mixing the waste and additives in a refractory crucible and placing the crucible in the furnace. If the off-gas was to be monitored for radon, a flow of 9.4 Lpm was initiated through the furnace after placing the crucible inside. The flow was allowed to continue overnight to allow a steady-state radon concentration to be reached in the off-gas stream. Ambient air was drawn into the furnace through an opening in the top and the out through a shell-and-tube heat exchanger. The off-gas stream then passed through a delay chamber to allow decay of radon-220 prior to monitoring of the off-gas stream, and through the vacuum pump to be vented to the hood. After the radon concentration in the off-gas had reached steady-state, the furnace was heated at a rate of 200°C/hr to the melt temperature of 1350°C. After holding at the melt temperature for two hours, the power was shut off and the furnace allowed to cool. During the heating and melting of the sample, a portion of the off-gas stream was periodically drawn through a Lucas 110A scintillation cell coupled to a Pylon AB-5 radon monitor to determine the radon concentration in the off-gas stream.

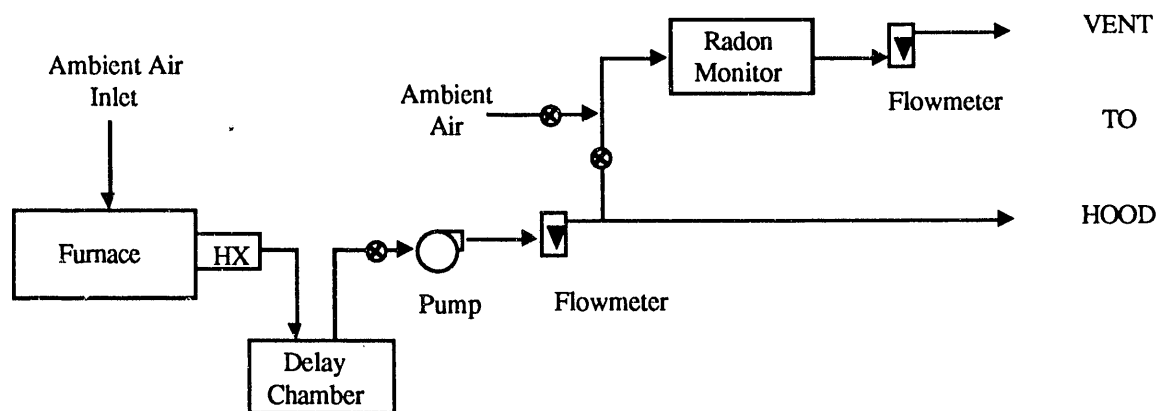

Fig. 1. Bench-Scale System for Monitoring Radon Release During Vitrification

Test Matrix

Vitrification of four different combinations of the wastes was investigated in these tests. Tests for the four compositions were termed sequences A through D. Sequence A consisted of K-65 material alone, sequence B was a 50:50 mixture by dry weight of K-65 and BentoGrout material, sequence C consisted of the Silo 3 material alone, and sequence D was a 70:30 mixture by dry weight of K-65 and Silo 3 material respectively. The four sequences represent potential waste compositions expected from various retrieval options.

Screening and Test Melts

The purpose of the screening melts was to identify formulations for each of the sequences which would provide the desired durability as determined by passing the TCLP test for metals. Using results of the previous tests and chemical analyses of the waste materials, different glass formulations were investigated for each sequence with melts

of approximately 100 grams each. Formulations were modified based upon the results observed, and additional screening melts performed. When an adequate waste form for each sequence was obtained based on visual observations such as homogeneity and glassiness of the vitrified product, the TCLP for metals was performed on the glass. Two glasses from each sequence were tested, and all of the glass samples passed this preliminary screening. One of the formulations from each sequence was then chosen for use in test melts of about 1000 grams each based upon the criteria of testing non-hazardous by the TCLP, visual observations of the vitrified product, and the opinions of the experimenters as to the most appropriate formulation for further study.

The 1000 gram melts were performed as previously described using the glass formulations reported in Table I. The composition of the K-65, Silo 3, and BentoGrout materials used in these tests is presented in Table II. Duplicate melts of each sequence were performed, and the radon released during vitrification was measured during the first melt of each sequence. Samples of the glass from each of the melts was tested for durability using the TCLP and PCT, and the conductivity and viscosity of the glass from each sequence was measured as a function of temperature. The estimated composition of the glass from each sequence is reported in Table III.

Table I. Glass Formulations for 1000 gram Melts (grams of dry material)

<u>Component</u>	<u>Sequence</u>			
	<u>A</u>	<u>B</u>	<u>C</u>	<u>D</u>
K-65	1,084	530	0	637
BentoGrout	0	530	0	0
Silo 3	0	0	1,008	273
Na ₂ CO ₃	231	218	0	214
Al ₂ O ₃	0	0	147	0
H ₃ BO ₃	0	0	88	0
SiO ₂	0	0	158	192
carbon	2	2	0	9

Table II. Composition of OU-4 Wastes (normalized wt% oxide)

<u>Component</u>	<u>K-65</u>	<u>Silo 3</u>	<u>BentoGrout</u>
Si	62.9	22.0	65.4
Pb	12.3	0.3	
Ba	6.3	0.1	
Fe	4.8	12.6	3.6
Al	3.7	8.3	15.8
Mg	1.7	15.8	6.3
Na	1.7	9.3	3.4
Ca	1.5	7.3	1.8
K	0.9	2.8	0.8
P	0.8	14.5	1.4
<u>other</u>	<u>3.5</u>	<u>7.2</u>	<u>1.5</u>
total	100.0	100.0	100.0

Table III. Estimated Glass Compositions for Sequences A to D (wt% oxide)

Element	Sequence			
	A	B	C	D
Si	54.3	56.3	30.0	56.9
Na	15.1	15.1	6.0	14.8
Pb	10.6	5.2	0.2	5.9
Fe	4.1	3.7	8.1	4.4
Mg	1.5	3.6	10.2	3.4
Al	3.2	8.7	20.0	3.1
Ba	5.4	2.7	0.0	3.0
P	0.7	1.0	9.4	2.8
Ca	1.3	1.4	4.7	1.9
K	0.8	0.7	1.8	0.9
B	na	na	5.0	na
Li	na	na	0.5	0.1
other	3.0	1.6	4.1	2.8
total	100.0	100.0	100.0	100.0

na - not analyzed in the K-65 waste, may be present as part of the "other" oxides.

RESULTS AND DISCUSSION

The purpose of these tests was to provide data to allow comparison of vitrification to other remediation technologies based upon the criteria of leachability of the final product, reduction in volume achieved through processing, and reduction in radon emanation from the waste material. These criteria are based upon the remediation concerns described previously. These tests were also to provide data regarding the feasibility of vitrifying the various waste compositions investigated. Results for both the performance of the glass product and the feasibility of processing for each of the sequences are reported below.

Radon Emanation from Vitrified K-65 Material

A significant concern for the K-65 material is the high rate of radon emanation resulting from the radium content of the waste. This is not a significant concern for the Silo 3 material due to the much lower radium content of that material. The radon emanation was measured from both the untreated waste and the vitrified product from sequences A, B, and D. Results of these measurements are presented in Table IV. The results for the non-vitrified residue were determined from the measured radon concentration in the gas stream flowing through the furnace containing the crucible filled with the waste and additives prior to vitrification. The emanation from the vitrified residue was too low to be measured in this open system; therefore, a closed system measurement technique was used. A sample of glass was sealed in a container and the radon concentration in the container was measured after 30 days. The radon emanation rate was then calculated based upon the estimated surface area of the glass in the sample container.

Table IV. Radon Emanation Rates from the Vitrified and Non-Vitrified K-65 Material

Sequence	Radon Emanation Rate (pCi/m ² /s)		
	Non-Vitrified	Vitrified	Non-Vitrified/Vitrified
A	29,976	0.059	508,000
B	11,817	0.024	492,000
D	13,961	0.030	465,000

The measurements show that a reduction in the radon emanation rate of 500,000 times is achieved through vitrification of the K-65 material. The reduction in emanation from the vitrified residue is likely to arise from several factors. It is believed that radium is often concentrated on the surface of grains of natural soils and minerals rather than uniformly distributed throughout the solid (2). In the vitrified residue, the radium will be uniformly

distributed throughout the solid, resulting in a lower radium concentration at the surface of the solid from which radon atoms are able to escape. Additionally, the vitrified product is a non-porous solid which is essentially impermeable to radon; therefore, only radon produced from radium within the recoil range of the surface (0.02 to 0.07 μm) is able to escape the solid (2). This is not the case for encapsulation technologies such as grout. The diffusion length of radon in concrete is reported as 0.06 to 0.2 m while for solids such as rock forming minerals it is estimated to range from 10^{-13} to 10^{-32} m (2). Most importantly, vitrification results in a large reduction in the specific surface area of the material. Radon emanation will decrease approximately in proportion to the specific surface area of the material since the radium is uniformly distributed throughout the volume of the vitrified residue and radon is able to escape from only a very small layer near the surface. An increase in particle size from 100 μm (typical for these residues) to 0.1 m (typical of a monolithic casting) results in a million fold decrease in the specific surface area, with a reduction in radon emanation estimated to be of the same order of magnitude.

It is interesting to compare the emanation rate from the vitrified waste with reported values for typical natural sources such as brick and concrete building materials. The radium content and emanation rate per unit area for the vitrified K-65 material and various typical natural materials are reported in Table V. This comparison shows that despite having a radium content one to ten thousand time greater than natural building materials, the emanation rate from the glass is as low or lower than from these materials. This comparison demonstrates the tremendous effectiveness of vitrification in reducing the radon emanation from radium bearing materials.

Table V. Comparison of Radon Emanation and Radium Content of Vitrified K-65 Material and Typical Natural Building Materials*.

<u>Material</u>	<u>Radium Concentration</u> (pCi/g)	<u>Rn Emanation Rate</u> (pCi/m ² /s)
Concrete	0.3 - 2.2	0.02 - 0.22
Alum Shale Concrete	10 - 70	0.4 - 1.5
Brick	0.5 - 5	0.02 - 0.04
Vitrified K-65 Material	2×10^5 - 3×10^5	0.01 - 0.06

* Data for the building materials is from Ref. 2.

Radon Release During Vitrification

In addition to radon emanation from the vitrified product, the release of radon during vitrification was also of interest. The radon concentration in the off-gas from the furnace was measured at thirty minute intervals throughout the course of vitrification. The measured off-gas concentrations as a function of time are shown in Figure 2 along with the temperature profile of the furnace. The concentration profiles show that radon release is significantly enhanced during vitrification. The increase is thought to arise from convective flow due to expansion of the gas in the pore space, water evaporation, and gas generation from inorganic decomposition. Also, radon normally trapped in the solid is likely freed and released during the melting and off-gassing of the solid. Two peaks are evident in the off-gas concentration profile. The first is thought to result from the convective flow due to water evaporation from the solid. Radon is carried out of the pore spaces by the convective flow of the water vapor rather than the normal diffusive flow. The second peak could result from the freeing of radon normally trapped within the solid, since many of the glass forming reactions begin to take place (with substantial gas generation) in the temperature range at which the peak is observed.

The total activity of radon released is obtained by multiplying the off-gas flow rate by the area under the curves. This can be compared to the theoretical maximum activity of radon based upon equilibrium with the radium present in the waste. These values are presented in Table VI. This data indicates that essentially all of the radon present in the waste will be released during vitrification. This is not surprising given the structural rearrangements and gas generation during the vitrification process. This data shows that the radon activity in the vitrification system off-gas can be estimated based upon the radium content of the waste. The difference between the measured and maximum activity is likely a result of radon lost from the sample during mixing of the waste with the additives and radon emanated to the off-gas stream while waiting overnight for a steady-state concentration to be reached.

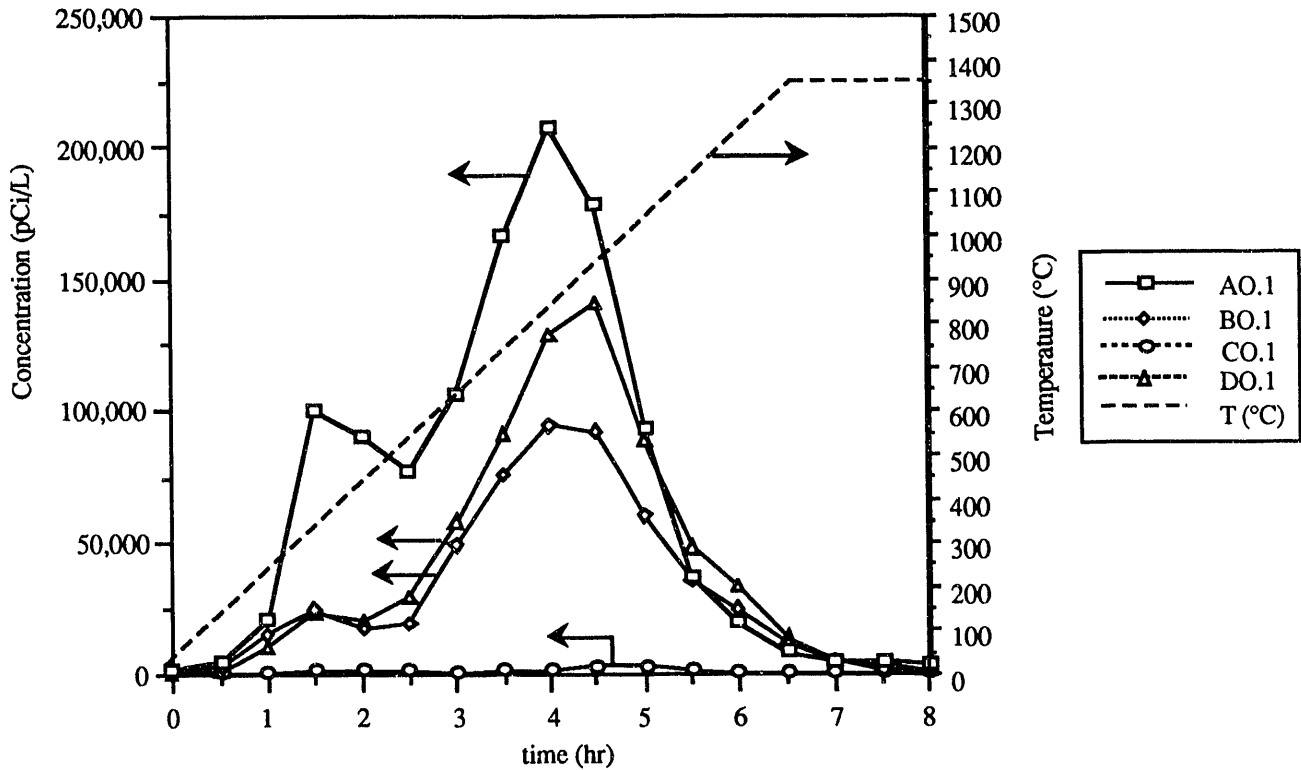

Fig. 2. Radon Emanation Profiles During Bench-Scale Vitrification of OU-4 Material (Off-Gas Flow of 9.4 Lpm)

Table VI. Radon Released During Vitrification of OU-4 Material (μCi)

<u>Sequence</u>	<u>Measured Rn-222 Activity</u>	<u>Maximum Rn-222 Activity</u>
A	320	363
B	151	178
C	5	5
D	199	215

Volume Reduction

A great benefit of vitrification is the significant reduction in waste volume typically achieved, even for inorganic solids. This was shown to be true for the four glass formulations in these tests. The volume reduction is defined as the percent difference between the initial waste volume and the final volume of the glass product. The volume reductions achieved in these vitrification tests ranged from 50 percent for sequence D to 55 percent for sequences A and B to 68 percent for sequence C. Another way to express this data is that the vitrified product volume ranged from 32 percent of the initial waste volume at best to 50 percent at worst. The significant reduction in volume can yield great benefits in terms of reduced waste disposal costs by decreasing the volume of waste requiring disposal.

TCLP results

A sample of the vitrified product from two melts of each of the sequences was crushed and sieved to a particle size of less than 4 mm diameter and sent to an independent analytical laboratory for TCLP testing. Results from these tests are presented in Table VII. The leachate concentrations of metals were less than the regulatory limits for all of the glasses; therefore, the vitrified residues test non-hazardous by the TCLP. Both the K-65 and Silo 3 residues have

been previously found to be hazardous using the EP Toxicity test (precursor to the TCLP tests). Leachate concentrations of lead for the K-65 material and arsenic, cadmium, chromium, and selenium for the Silo 3 material were found to exceed the toxicity limit (1,3). A comparison of these TCLP results from the vitrified residue and previous results of the similar test for the non-vitrified residue shows that lead concentrations in the leachate have been reduced one thousand fold for the K-65 residue, while for the Silo 3 material, arsenic concentrations in the leachate have been reduced nearly a hundred fold and cadmium, chromium, and selenium were reduced to less than or near less than detectable levels.

Table VII. TCLP Leachate Concentrations of Selected Metals for Vitrified OU-4 Residues (mg/L)

<u>Metal</u>	<u>Sequence A</u>	<u>Sequence B</u>	<u>Sequence C</u>	<u>Sequence D</u>	<u>Regulatory Limit</u>
Arsenic	0.004 - 0.005	0.003 - 0.03	0.47 - 0.79	0.038 - 0.067	5.0
Barium	0.69 - 0.87	0.43 - 0.56	0.028 - 0.074	1.6 - 2.0	100
Cadmium	<0.005	<0.005	0.007 - 0.012	<0.005	1.0
Chromium	<0.01	<0.01	<0.01	<0.01	5.0
Lead	0.81 - 1.2	0.38 - 0.47	0.017 - 0.019	0.50 - 0.58	5.0
Mercury	<.0002	<.0002	<.0002	<.0002	0.2
Selenium	<0.002	<0.002	<0.002	<0.002	1.0
Silver	<0.01	<0.01	<0.01	<0.01	5.0

Table VIII reports the percent of the total amount of each element initially present in the glass which was extracted into the leachant in the TCLP for major components of the glass. The values generally range from about 0.01 to 0.04 percent of the element leaching out of the glass. Since the TCLP is not a typical test for leach resistance of glasses, comparison of these figures to existing data is difficult; however, assuming a surface area of 0.0005 m²/g for the TCLP glass sample (equivalent to a particle diameter of 4 mm), this represents a normalized leach rate of about 0.2 to 0.8 g/m²/d. Higher levels of leaching were observed for potassium, magnesium, calcium, barium, and phosphorus, especially in the sequence C and D melts. There appears to be a correlation between the leaching of the alkali earth metals (with the exception of radium) and phosphorus, possibly indicating the presence of alkali earth phosphates which are more readily leached than the remainder of the glass matrix under the conditions of the TCLP. The increase in the leach rate of these elements also corresponds with an increase in phosphorus content of the glasses, with the highest leach rate at the highest phosphorus content. This increased leaching, however, was shown to not affect the ability of the glasses to prevent the release of hazardous constituents.

Table VIII. Ratio of the Total Amount of the Element in the Leachant to the Total Amount Initially Present in the Waste Expressed as a Percent for Major Elements in the Glass

<u>Element</u>	<u>Sequence</u>			
	<u>A</u>	<u>B</u>	<u>C</u>	<u>D</u>
Si	0.014	0.010	0.038	0.012
Pb	0.020	0.018	0.020	0.020
Ba	0.032	0.012	0.338	0.131
Al	0.019	0.042	0.007	0.015
Ca	0.065	0.033	0.511	0.178
Mg	0.032	0.133	0.388	0.057
K	0.079	0.084	0.092	0.075
P	0.044	0.206	0.467	0.141
Ra-226	0.029	0.03+	0.029	0.026

Radionuclide concentrations were also measured in the TCLP leachates. The majority of the activity present in the leachates was from radium-226, with levels ranging from about 2 to 4.6 nCi/L for the glasses containing K-65 material (Sequences A, B, and D). These relatively high radium levels are the result of the high radium content of the waste, not from a failure of the glass to retain the radium. The data of Table VIII indicate that radium was found to leach at rates approximating the leach rates for silica, alumina, and lead. There is not evidence of selective leaching of the radium from the glass.

PCT results

Leach testing was also performed on samples from each of the melts using the PCT. The PCT is a seven-day static leach test developed for the high-level waste vitrification program. The test uses deionized water at 90°C to leach a glass sample which has been crushed and sieved to a size fraction of -100/+200 mesh. Since the size fraction of the glass is controlled, the results of this test are readily expressed on a basis of surface area of the glass, whereas for the TCLP, the surface area of the sample is an unknown or ill-defined quantity. The PCT is much more useful for determining actual leach rates for the glass.

Results of the testing for the sequence A through D glasses are presented in Table IX. Leach rates for boron could not be determined for glasses containing K-65 because its initial concentration in the glass was not determined; however, boron was present only at very low levels in the leachate from sequences A, B, and D. The normalized leach rates found for these glasses are one to two orders of magnitude below the proposed limit of 1 g/m²/d for high-level waste glasses. These results, therefore, show the glasses formulated for the OU-4 wastes to be extremely durable on a comparable basis to glasses developed for high-level waste.

Table IX. Normalized Leach Rates for PCT Leaching of OU-4 Glasses (g/m²/d)

Element	Sequence			
	A	B	C	D
K	0.018	0.006	0.006	0.016
Na	0.088	0.028	0.012	0.043
Si	0.022	0.010	0.008	0.017
Li	0.000	0.000	0.022	0.029
B	(a)	(a)	0.010	(a)

(a) - Initial concentration in glass unknown

Comparing the estimated leach rates from the TCLP with the leach rates determined by the PCT shows the glasses to be leached significantly more in the TCLP. Two explanations for this are possible. First, when the glass sample is crushed to the TCLP requirement of <9.5 mm, substantial quantities of very fine glass particles are generated. In our tests we estimate as much as one to two percent of the mass of the glass could have been reduced to very fine particles. Since these fines are included in the sample during leaching, the actual surface area of the sample can be much higher than the area estimated based on the size of the large particles, resulting in inflated leach rates. Second, the leaching behavior of glasses is highly dependent on the conditions of the test. Testing on simulated high-level waste glasses has shown that some glasses which are very durable at neutral conditions are more readily leached at acid conditions, and some glasses resistant to leaching at acid conditions are readily attacked at neutral conditions (4). It is not surprising, therefore, that the leaching results for the TCLP and the PCT are significantly different. When considering these tests, it should be realized that the TCLP is not a test to determine glass leach rates, but rather to determine the toxicity characteristic of a material. On this basis, the TCLP testing of these glasses has shown them to be non-hazardous and the PCT results indicate the glasses are chemically durable.

Vitrification Feasibility

The above results have demonstrated the applicability of vitrification to the K-65 and Silo 3 residues based upon the performance of the vitrified product. The residues have been vitrified alone and in various combinations. The scope of this work concentrated on the ability to convert the wastes into a vitrified product and the performance of the resulting glasses. Processing considerations, however, are also important in addition to the waste form performance. Measurements and observations regarding important processing considerations for these wastes are described below.

The viscosity and electrical conductivity of the vitrified products were measured for each of the glass formulations. The temperature at which the glasses have a viscosity of 10 Pa·s and the electrical conductivity at this temperature are reported in Table X. These values are predicted based upon experimentally measured data points; for sequence B

there was substantial extrapolation. The glasses from sequences A, C, and D were all found to be processable at temperatures readily attainable in a joule-heated melter. The sequence B glass was more viscous due to the higher alumina content resulting from the addition of BentoGrout to the waste. The electrical conductivities for all the glasses were within acceptable ranges for processing in a joule-heated ceramic melter (0.1 to 0.5 ohm⁻¹cm⁻¹). These results indicate that processing of these waste glasses is possible in a joule-heated ceramic melter. Some modification of the glass formulation will be necessary for the sequence B glass to obtain appropriate viscosities.

Table X. Processing Temperature for a Glass Viscosity of 10 Pa·s and the Conductivity at That Temperature

<u>Sequence</u>	<u>Temperature (°C) for a Viscosity of 10 Pa·s</u>	<u>Electrical Conductivity (ohm⁻¹cm⁻¹)</u>
A	1383	0.28
B	1595	0.35
C	1289	0.08
D	1413	0.27

Due to the sulfate content of these wastes, the accumulation of a molten salt layer during melting is a concern. The K-65 material contains approximately 2 wt% sulfate, while the Silo 3 material contains about 18 wt% sulfate. During the screening tests, salt layers were observed on melts including K-65 material, but not on those with only Silo 3 material. The addition of small amounts of carbon to the formulation was found to eliminate the sulfate layer on the surface of the glass. The addition of carbon, however, can lead to the formation of a reduced metal phase in the melt. Nodules of reduced metal were found in both 1000 gram melts of sequence A, but were not observed in either sequence B or D. The 1000 gram melts for sequence D formed a separate salt layer about 1/32 of an inch thick even though the same formulation in the screening melt was free from a salt layer. The sequence C melt did not require an addition of carbon, even though the sulfate concentrations in the Silo 3 waste are ten times higher than in the K-65 material. These tests demonstrated that a salt layer resulting from the presence of sulfates in the waste can be potentially be controlled with additions of a reductant to the feed. The results from sequence C show that different glass formulations may also be used to avoid the formation of a sulfate layer.

In the melts of sequences A, B, and D, a few large (about 1 to 5 mm diameter) crystalline inclusions were present in the glass. These inclusions were typically white and were generally found at the surface of the glass. They were not excluded from the leach testing of the glass; therefore, their presence does not appear to have an adverse impact upon the durability of the glass. However, further development should identify the composition of these inclusions and attempt to modify the formulations to obtain a homogeneous glass.

The above discussion indicates that vitrification of the K-65 and Silo 3 materials in a joule-heated ceramic melter appears to be feasible. Potential concerns regarding the separation of a salt layer in the melt appear to be addressable through appropriate formulation of the glass. Further development of the glass formulations should address the issues discussed above.

CONCLUSIONS

Bench-scale crucible melts in a laboratory furnace have demonstrated the applicability of vitrification to the waste material from OU-4 of the FMPC. Vitrification of the wastes has been demonstrated to provide significant benefits, including reduction in radon emanation from the waste, significant reduction in volume of the waste, and immobilization of hazardous constituents within the glass structure. The vitrified product has demonstrated exceptional performance in addressing the remediation concerns for the OU-4 silos. Data from these tests indicate that glass formulations for the OU-4 wastes would be processable in a joule-heated ceramic melter. Concerns regarding the formation of secondary phases appear to be addressable through modifications of the formulations; however, additional development of the glass formulations should be pursued.

REFERENCES

1. JANKE, D. S., C. C. CHAPMAN, AND R. A. VOGEL, "Results of Vitrifying Fernald K-65 Residue," Fifth International Symposium on Ceramics in Nuclear and Hazardous Waste Management, Cincinnati, Ohio, April 29 - May 3, 1991, American Ceramic Society (1991).
2. NAZAROFF, W. W. AND A. V. NERO, JR., ED., Radon and Its Decay Products in Indoor Air, John Wiley and Sons, New York (1988).
3. U. S. DEPARTMENT OF ENERGY. "Remedial Investigation Report for Operable Unit 4: Task 6 Report," FMPC-0406-5 (October 1990).
4. CHICK, L. A., G. F. PIEPEL, G. B. MELLINGER, R. P. MAY, W. J. GRAY, C. Q. BUCKWALTER, "The Effects of Composition on Properties in an 11-Component Nuclear Waste Glass System," PNL-3188, Pacific Northwest Laboratory (September 1981).

END

**DATE
FILMED**

6 / 24 / 93