

30
11/14/88 JSC

DP# 0594-0

THE RF PHASE SYSTEM OF THE SLC*

R. K. JOBE, J. E. CLENDENIN, H. D. SCHWARZ, J. T. SEEMAN, J. C. SHEPPARD, AND R. F. STIENING

Stanford Linear Accelerator Center, Stanford University, Stanford, California 94309

ABSTRACT

The phases of the RF throughout the SLC accelerator complex play an important part not only in the energy and energy spread of the beams at the end of the linac, but also in the production process of both electrons and positrons. Proper machine operation requires that certain phase relationships be maintained between the RF systems of the electron source, the electron and positron damping rings, the linac, and the positron source. This paper presents an overview of the interplay of the various RF phases throughout the SLC accelerator complex as well as describing various hardware and software inter-connections which have been made to facilitate control of the system as a whole. In addition, a description is given of RF phase monitoring required for system control. Operational experience and future plans are also discussed.

HISTORICAL OVERVIEW

The Stanford Linear Accelerator was originally built to support the traditional single beam physics operations popular around 1966. While the linac was upgraded over the past several years to support the SLC, with its high-charge, low-

emittance multi-bunch operation, much of the original RF distribution plant is still used.

The design considerations of the RF controls¹ for SLC were constrained by the need to inject positrons produced in any given machine cycle into the damping rings. This presents unusual phasing and timing constraints, since the same linac booster section is used to accelerate electrons from the gun with the returning positrons, while the phase of the positrons is determined by the phase of the electron bunch extracted from the damping ring only 13 μ s prior to positron injection.

RF CONTROLS

The RF system is designed to allow orthogonal control of the energy and energy spread of both the positrons and the primary electrons in the linac (see Figure 1). Due to the nature of the RF systems involved, it is not possible to orthogonalize the energy controls for the primary beams to the interaction point. The positrons are produced by the second bunch of electrons in the North Damping Ring (NDR). These electrons are extracted as the third linac bunch following the positrons and primary electrons, and kicked out of the

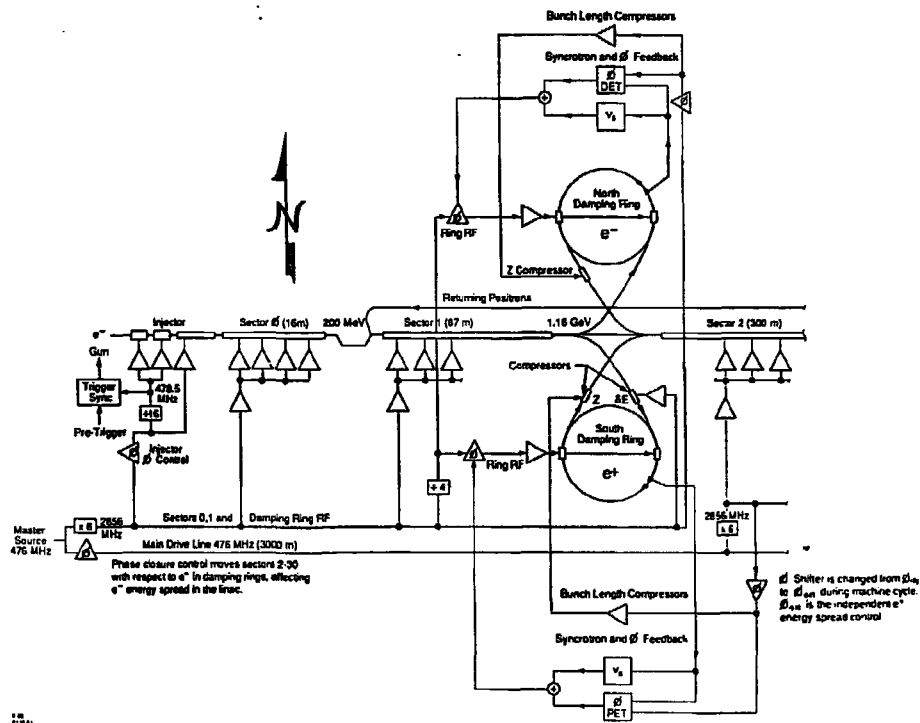

Fig. 1. RF distribution for the front end. Details show sources of RF for injector area, booster section, and damping rings.

*Work supported by the Department of Energy, contract DE-AC03-76SF00515.

Presented at the 1988 Linear Accelerator Conference (LINAC 88), Williamsburg, Virginia, October 3-7, 1988

MASTER

linac at the positron source area. Positrons are produced, captured, accelerated to 200 MeV, and returned to the front end of the linac for final booster acceleration prior to injection in the South Damping Ring (SDR). Because any changes in the phase of the North (electron) Damping Ring directly affect the phase of the newly produced positrons (see Figure 2), and therefore the energy spread introduced by the booster prior to injection, the controls are designed to leave the electron damping ring phase stable.

BEAM MONITORING

Energy and energy spread of both the e^+ and e^- beams are measured both at the Linac to Ring (LTR) transport line upstream of the damping rings, and at the Beam Switchyard (BSY) area upstream of the SLC arcs. Energy is analyzed using beam position monitors in the linac and at high dispersion points in the transport lines. Readings from the dispersive BPMs are corrected for any observed launch errors, and the energy offset is computed. Energy spread (δE) is observed either by inserting profile monitors, or by using the X-ray synchrotron light produced by a wiggler at a high dispersion point in the BSY.

ENERGY CONTROLS

Energy controls for the SLC are limited to three classes of devices: in the front end, where small corrections are required, variable drive klystrons are used; in the linac, whole sectors are mis-phased to control the energy; and for the two bunch differential energies ($E^+ - E^-$), timing controls for the SLED discharge are used.

Upstream of the damping rings there are two klystron stations which are equipped with special calibrated variable drive attenuators² (see Figure 3). These are used individually and in combination to control the energy of the electrons and the returning positrons, and provide energy adjustment of about 100 MeV.

Linac energy control uses entire sectors of klystrons which are symmetrically counter-phased (see Figure 4). This "kinking" of the accelerator sectors allow control of the delivered beam energy, with an adjustment range of several GeV. The use of two sectors allow the control of energy without affecting energy spread.

Energy difference between the positron beam and the electron beam cannot be achieved with the use of conventional RF controls. This control takes advantage of the 60 nanosec-

ond spacing of the positron to electron bunches, and the discharge control timing for the SLED energy doubler cavities. The positrons are deliberately launched when the accelerating cavities are incompletely filled, the electrons arriving some time later when the beam loading of the first bunch is compensated for by the more complete RF fill of the accelerator for the second bunch (e^-). No control is available for the third bunch in the linac which is used in the production of positrons.

ENERGY SPREAD CONTROL

Energy spread is controlled by varying the position of the bunch in question with respect to the accelerating RF field. The controls available to both the operations staff and the feedback processes generally vary the phase for the entire linac. The energy spread control tool is different for each of the four beams controlled.

Control of the electron energy spread for the primary bunch is achieved by changing the phase of the Main Drive Line, which supplies RF for sectors 2-30. Because the electron bunch phase feedback for the North Damping Ring is referenced to the injector area phase source, and any change in the 2-30 control varies the electron bunch's δE without affecting the phase of the scavenger electron bunch or the phase of the returning positrons.

Control of the positron energy spread is achieved by changing the extraction phase control for the South Damping Ring phase feedback. This results in a phase change in the damping ring with respect to the 2-30 RF source. This control is only active for extraction, and only affects the positron bunch.

Control of the energy spread of the electrons injected into the North Damping Ring is achieved by either varying the CID injector area master phase control, which varies the phase of the bunched beam entering sectors 0 and 1, or by varying the phase of sector 0 independently. Both control affect the δE of the beam, and operationally there are arguments which favor each option.

Control of the positron bunch energy spread prior to injection into the damping rings can be done either by varying the physical transport line length using a mechanical mover which moves the East Turnaround magnets, or by directly changing the phase control for sector 1. Varying this phase control also affects the energy and energy spread of the electron bunch, which must be compensated for by moving several other phase knobs in the sector 0 area. Because the emittance of the positron bunch is very large, considerable attention is paid to the tune of this system to maintain injection efficiency.

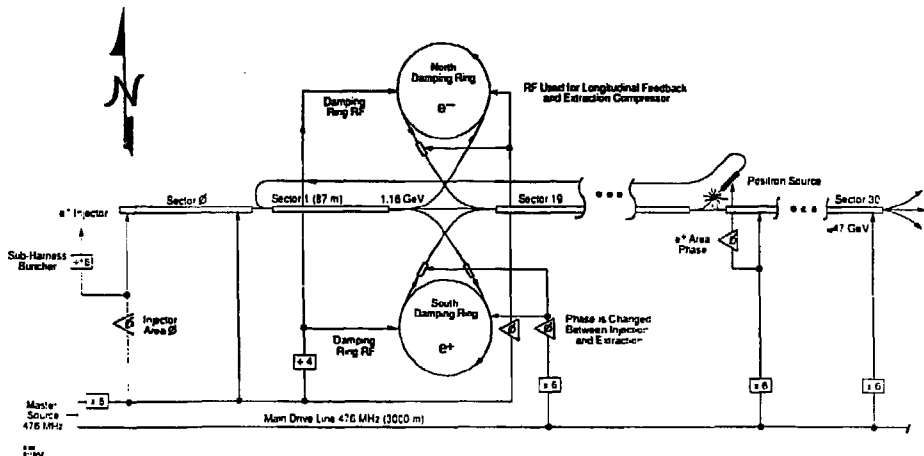

Fig. 2. The reference RF for most of the linear accelerator and the positron source area is supplied from the Main Drive Line.

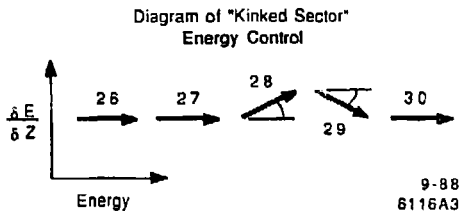

Fig. 3. Vernier klystron stations are used in the injector and booster areas of the linac. The klystrons are operated in their linear power range.

HARDWARE SUPPORT

In the upgrade for the SLC, the global RF distribution system originally installed is still used. This consists of a two-mile-long rigid coaxial cable (the Main Drive Line), which is the primary RF source for all devices in sectors 2-30. The klystrons are divided into sectors of 100 meters, each containing a sub-booster (klystron) RF driver and eight klystrons.

As part of the upgrade, phase reference lines were added in each sector, and phase and amplitude monitors were installed at each RF source. Control of the RF sources was instrumented,³ and regular phase trimming to accepted values is standard operational procedures (rate=12/hour). This phase trimming, control and readback has been implemented throughout the SLC.

In the injector and booster area of the SLC, there has been a significant effort to upgrade the RF sources and controls: damping Rings have been added which require RF at the fourth subharmonic of the linac RF (714 MHz), and sub-harmonic bunchers have been added to the gun area, running at the a sixteenth of the linac frequency (178.5 MHz).

FEEDBACK SYSTEM

There are a number of feedback systems and processes which are focused on the stabilization of beam parameters. These systems represent loops which stabilize the traditional x , x' , y , and y' components of the beam trajectory,⁴ and those which actively minimize beam phase, energy, and energy spread errors.⁵ The latter systems fall into three classes: The damping ring systems, where feedback is entirely in dedicated hardware systems, and the rest, where systems are divided between control by a slow feedback process in the central computer, and systems in dedicated microcomputers which attempt to respond on a pulse-to-pulse basis.

DAMPING RING FEEDBACK SYSTEMS

The two damping rings are equipped with feedback systems which are designed to suppress the synchrotron oscillations and correct beam phase.⁶ These two loops use BPM data for the feedback.

The synchrotron loop uses a BPM which is $\pi/2$ betatron cycles from the RF cavities in the ring. Energy errors are seen by the hardware as transverse motions in the orbit, and are reduced. This is a very fast loop, and stabilizes the motion in about 100 μ s.

The beam phase stabilization loop plays a pivotal role in the operation of the accelerator. The hardware consists of a phase detector which can compare phase of the fast BPM signal with a 2856 MHz reference signal. As shown on the detailed figure for the front end, the phase reference for each ring is different, allowing separate energy spread corrections with unaffected positron injection conditions. This is a slower loop, which is not activated until the synchrotron feedback has corrected any errors.

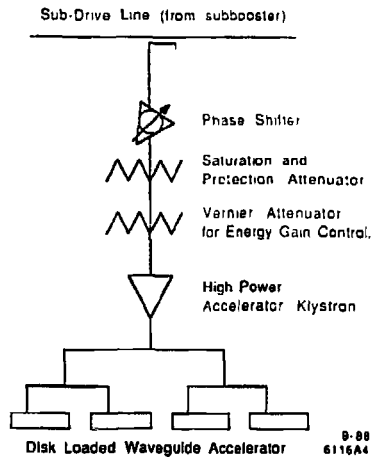

Fig. 4. Vector diagram of "kinked sector" energy control for the linac. Two sectors are symmetrically counter-phased to control energy gain.

SLOW FEEDBACK STABILIZATION PROCESS

Slow feedback loops are controls and corrections which are driven from a process on the central control computer; the speed of the correction algorithms is limited to about 1 correction per minute. This was the first computer-based feedback system at SLAC, and initially contained all correction systems required for SLC operation. The experience is that some corrections need to be done on a much faster basis, and have been moved to a dedicated microprocessor.

An example of controls which have been successfully driven from the slow loop is the correction for temperature and pressure dependencies in the Main Drive Line, where driving terms have frequencies measured in hours rather than minutes.

FAST FEEDBACK MICROS

The fast loops are driven by dedicated micros, which have BPM electronics and controls directly under their control. The RF controls which this class of feedback system is controlling is the energy and energy spread at the end of the linac. The same BPMs and X-ray screens are used by these micros and the central computer. Direct controls are provided to allow the micro to make small changes to the phase of two kinked sectors, allowing energy control, and the energy spread control phase shifters in the injector and damping ring areas. The initial experience is that the operability of the machine is greatly enhanced by the addition of the fast energy controls.

REFERENCES

1. H. D. Schwarz, Computer Control of RF at SLAC, *Proceedings of the IEEE Particle Accelerator Conference*, IEEE Trans. NS-32 (October 1985).
2. R. K. Jobe et al., Computer Control of the Energy Output of a Klystron, *Proceedings of the IEEE Particle Accelerator Conference*, Washington, D.C., March 1987.
3. R. K. Jobe et al., Klystron Control Software in the SLC, *Proceedings of the IEEE Particle Accelerator Conference*, IEEE Trans. NS-32 (October 1985).
4. K. A. Thompson et al., Position, Angle and Energy Stabilization for the SLC Positron Target and Arcs, *Proceedings of the IEEE Particle Accelerator Conference*, Washington, D.C., March 1987.
5. J. C. Sheppard et al., Three Bunch Energy Stabilization for the SLC Injector, *ibid.*
6. H. D. Schwarz and J. D. Judkins, Phase Detector and Phase Feedback for a Single Bunch in a Two-Bunch Damping Ring for the SLAC Linear Collider, *ibid.*