

27
1-27-83
JMP

I-7552 (1)

Dr. 1137

UCID- 19487
AFWAL-TR-82-3076

MATRIX-DOMINATED TIME-DEPENDENT DEFORMATION
AND DAMAGE OF GRAPHITE EPOXY COMPOSITE
EXPERIMENTAL DATA UNDER RAMP LOADING

Edward M. Wu
Richard L. Moore
Nhan Q. Nguyen

DO NOT MICROFILM
COVER

November 1982

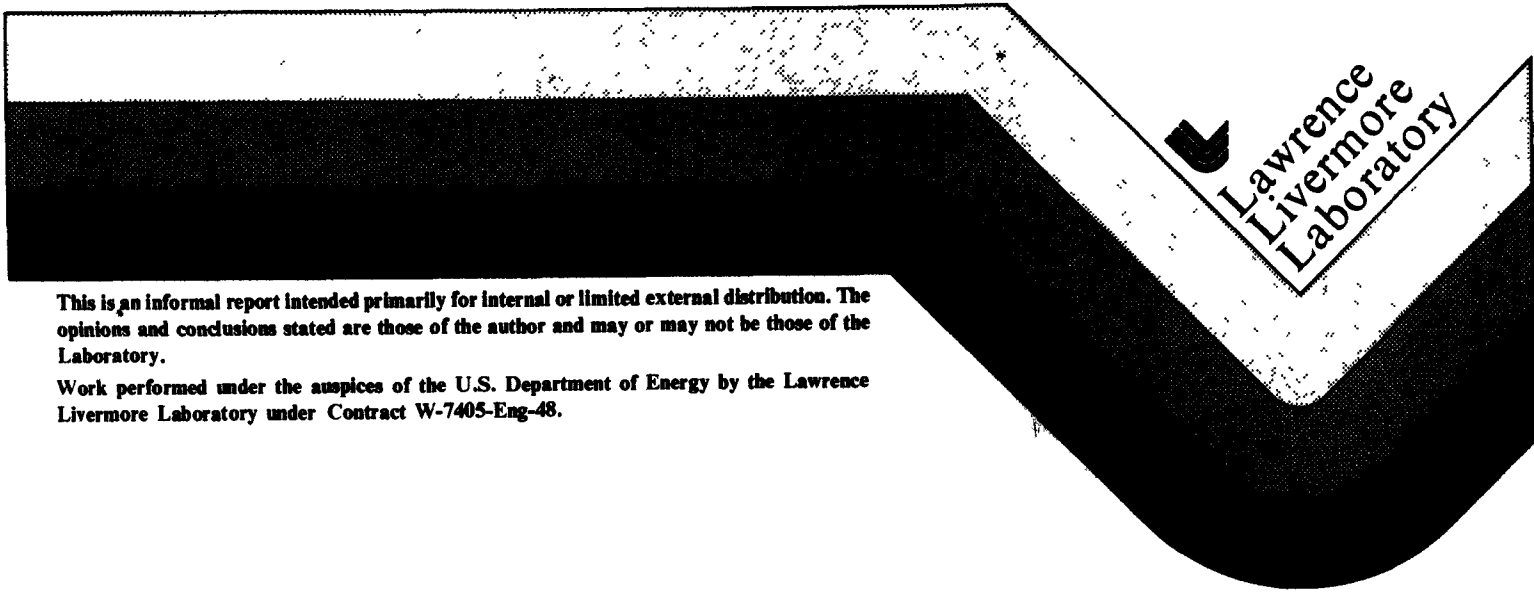

This is an informal report intended primarily for internal or limited external distribution. The opinions and conclusions stated are those of the author and may or may not be those of the Laboratory.

Work performed under the auspices of the U.S. Department of Energy by the Lawrence Livermore Laboratory under Contract W-7405-Eng-48.

MASTER

DISTRIBUTION OF THIS DOCUMENT IS UNLIMITED

DISCLAIMER

This report was prepared as an account of work sponsored by an agency of the United States Government. Neither the United States Government nor any agency Thereof, nor any of their employees, makes any warranty, express or implied, or assumes any legal liability or responsibility for the accuracy, completeness, or usefulness of any information, apparatus, product, or process disclosed, or represents that its use would not infringe privately owned rights. Reference herein to any specific commercial product, process, or service by trade name, trademark, manufacturer, or otherwise does not necessarily constitute or imply its endorsement, recommendation, or favoring by the United States Government or any agency thereof. The views and opinions of authors expressed herein do not necessarily state or reflect those of the United States Government or any agency thereof.

DISCLAIMER

Portions of this document may be illegible in electronic image products. Images are produced from the best available original document.

AFWAL-TR-82-3076

**MATRIX-DOMINATED TIME-DEPENDENT DEFORMATION
AND DAMAGE OF GRAPHITE EPOXY COMPOSITE
EXPERIMENTAL DATA UNDER RAMP LOADING**

UCID--19487

DE83 005706

**EDWARD M. WU
RICHARD L. MOORE
NHAN Q. NGUYEN**

**Lawrence Livermore National Laboratory
Livermore, CA 94550**

November 1982

NOTICE

**INTERIM REPORT FOR PERIOD
JANUARY 1977 TO DECEMBER 1978**

**PORTIONS OF THIS REPORT ARE ILLEGIBLE. It
has been reproduced from the best available
copy to permit the broadest possible avail-
ability.**

Approved for public release; distribution unlimited.

**FLIGHT DYNAMICS LABORATORY
AIR FORCE WRIGHT AERONAUTICAL LABORATORIES
AIR FORCE SYSTEMS COMMAND
WRIGHT PATTERSON AIR FORCE BASE, OHIO 45433**

DISCLAIMER

This report was prepared as an account of work sponsored by an agency of the United States Government. Neither the United States Government nor any agency thereof, nor any of their employees, makes any warranty, express or implied, or assumes any legal liability or responsibility for the accuracy, completeness, or usefulness of any information, apparatus, product, or process disclosed, or represents that its use would not infringe privately owned rights. Reference herein to any specific commercial product, process, or service by trade name, trademark, manufacturer, or otherwise, does not necessarily constitute or imply its endorsement, recommendation, or favoring by the United States Government or any agency thereof. The views and opinions of authors expressed herein do not necessarily state or reflect those of the United States Government or any agency thereof.

DISTRIBUTION OF THIS DOCUMENT IS UNLIMITED

PLG



.

.

.

.



Unclassified

SECURITY CLASSIFICATION OF THIS PAGE (When Data Entered)

REPORT DOCUMENTATION PAGE		READ INSTRUCTIONS BEFORE COMPLETING FORM
1. REPORT NUMBER AFWAL-TR-82-3076	2. GOVT ACCESSION NO.	3. RECIPIENT'S CATALOG NUMBER
4. TITLE (and Subtitle) Matrix-Dominated Time-Dependent Deformation and Damage of Graphite Epoxy Composite Experimental Data Under Ramp Loading	5. TYPE OF REPORT & PERIOD COVERED Interim Report Jan. 1977 - Dec. 1978	
	6. PERFORMING ORG. REPORT NUMBER UCID 19487	
7. AUTHOR(s) Edward M. Wu, Richard L. Moore, Nhan Q. Nguyen	8. CONTRACT OR GRANT NUMBER(s) MIPR FY 1456-81-0014	
9. PERFORMING ORGANIZATION NAME AND ADDRESS Lawrence Livermore National Laboratory Livermore, CA 94550	10. PROGRAM ELEMENT, PROJECT, TASK AREA & WORK UNIT NUMBERS 2307 2307N1 2307N106	
11. CONTROLLING OFFICE NAME AND ADDRESS Flight Dynamics Laboratory (AFWAL/FIBE) AF Wright Aeronautical Laboratories Wright-Patterson Air Force Base, Ohio 45433	12. REPORT DATE November 1982	
	13. NUMBER OF PAGES 116	
14. MONITORING AGENCY NAME & ADDRESS (if different from Controlling Office)	15. SECURITY CLASS. (of this report) Unclassified	
	15a. DECLASSIFICATION/DOWNGRADING SCHEDULE	
16. DISTRIBUTION STATEMENT (of this Report) Approved for public release; distribution unlimited.		
17. DISTRIBUTION STATEMENT (of the abstract entered in Block 20, if different from Report)		
18. SUPPLEMENTARY NOTES		
19. KEY WORDS (Continue on reverse side if necessary and identify by block number) Composites Graphite-Epoxy Ramp Loading		
20. ABSTRACT (Continue on reverse side if necessary and identify by block number) The objective of this report is to disseminate experimental data of matrix-dominated time-dependent deformation and time-dependent damage in graphite-epoxy composite. The composite specimens were + 45° T300/5208 laminates tested in tension with complete instrumentation for stress, strain, and time recordings. Experimental data was recorded and archived in digital form. Polynomial series are fitted to the experimental data for compilation, dissemination and future retrieval. Data presented herein is accessible to the		

20. technical community at large for correlation and the formulation of theory from diverse perspectives, and to meet different goals in fundamental research and engineering applications.

PREFACE

The work reported herein was performed by the Lawrence Livermore National Laboratory under the auspices of the U.S. Department of Energy under contract No. W-7405-ENG-48. Funding was provided by the Flight-Dynamics Laboratory of the Air Force Wright Aeronautical Laboratories, Wright-Patterson Air Force Base, Ohio 45433, under MOU/MOA entitled "Spectrum Load/Environment Effects in Advanced Fiber Reinforced Laminates," Project 2307, Work Unit 2307N106. Dr. G. P. Sendeckyj, AFWAL/FIBE, was the Air Force Program Monitor.

This program was conducted by the Materials Test and Evaluation Section of the Mechanical Engineering Department, and the Polymers and Composite Mechanics Program, both of the Lawrence Livermore National Laboratory. The work was directed by Dr. E. M. Wu, experimental mechanics performed by Mr. R. L. Moore, and data reduction software by Mr. N. Q. Nguyen.

TABLE OF CONTENTS

	Page
I. Introduction and Scope	1
II. Material, Specimen Preparation, and Sample Configuration . .	2
III. Experimental Configuration	3
IV. Data Compilation Procedure	4
V. Data Retrieval	7
Appendix - Experimental Data Under Ramp Loading	21

I. Introduction and Scope

The structural application of composites with specified reliability targets require quantitative characterization of the composite's time-dependent deformation and time-dependent damage properties. The inherent variability of damage requires extensive replication of tests and a large number of samples. The very nature of time-dependent characterization coupled with the large number of specimen requirements leads to the necessity of occupying testing facilities for extended periods of time. As a matter of practical constraints, it is frequently not feasible to test the numerous permutations of fiber, matrix, lamination geometries, and load-history profiles. Significant reduction of the testing and data managing effort is possible by first characterizing the basic (or local) aspect of time-dependent deformation and damage separately for the fiber and for the matrix, and then by computing the overall composite performance by mechanistic modeling. In graphite-epoxy composites, it is known that the fiber properties are weakly time-dependent; our program is therefore directed towards the characterization of matrix dominated time-dependent properties. The specimens are T300/5208, $\pm 45^\circ$ laminates tested in tension. This configuration characterized the matrix dominated behavior under combined normal and shear stresses as well as interlaminar stresses. Further partitioning of these effects requires interfacial strength characterization and supplemental testing of the lamina in pure shear and in uniaxial transverse tension. These characterizations were not included in this program.

The scope of this program is to provide a data base which can be used to characterize overall matrix-dominated time-dependent deformation and time-dependent strength. Three load-histories (ramp loading, step and hold loading, creep and recovery loading) were performed to facilitate identification of non-linearity in proportionality and non-linearity in time-superposition. The data

base includes a complete recording of the mechanical stimuli (the input) and the material responses (the output) by macro-variables of stress and strains. Emphasis in this report is on presentation of the data so that it may be accessible to the technical community at large and to facilitate correlation and formulation of mechanistic models from diverse perspectives to meet different goals in fundamental research and in engineering applications. Part I of this report summarizes the data base established for ramp loading.

II. Material, Specimen Preparation, and Sample Configuration

The material tested in this program was Narmco T300/5208 Graphite-epoxy currently widely used by the aerospace industries for structural components of high performance aircrafts.

All samples tested were coupons machined from $(\pm 45)_S$, i.e., four ply ± 45 symmetric laminates. The 12" x 12" laminates were fabricated from prepregs supplied by the manufacturer. The fabrication method was by vacuum bag molding using scrim cloth to control fiber volume to be $61\% V_f \pm 2\%$. The laminates were cured in accordance with the manufacturer's specification which included vacuum evacuation in vacuum-bag; increased temperature from room temperature to 130°C and held 1 hour at 135°C . Raised temperature to 179°C and held for 2.5 hours with autoclave pressure at 100 psi. Allowed to cool down overnight to 60°C . Post-cure followed a 6-hour ramp to 204°C , held for 4.5 hours at 204°C , followed by a 6-hour ramp-down to room temperature. Commercially available glass-fiber cloth reinforced circuit board material was used to provide jaw cushioning for the tensile coupons. Strips of this glass tab materials were bonded to the 30 cm x 30 cm laminate as shown in Fig. 1a.

Coupon samples were machined from the plate by a water-cooled diamond cut-off disk, and then precision drilled in a jig, producing the finished specimen with the configuration indicated in Fig. 1b.

The finished specimens were inspected for irregularities and machining damage by a 10X stereo microscope. Finally, 350 Ω strain gauges were affixed to the samples as illustrated in Fig. 2. Three gauge rosettes ($0^\circ/45^\circ/90^\circ$) were used to collect additional information for identifying damage associated with delamination.

III. Experimental Configuration

The ramp-test loading reported here was performed on a standard metric-model Instron Testing Machine with fine pitch cross-head screws. The range of the standard Instron cross-head rates were extended by serially connecting an Instron table model gear box to the Selsyn motor. Using this extended range, we carried out the testing matrix as indicated in Table 1.

The specimens were loaded by displacement conditions (not strained controlled), and the displacement rates were nominally constant. The deviation from constant rates are greatest at the slowest cross-head rates. In any case, it would be inappropriate to interpret the data as constant strain rate and substitute directly in the constitutive relations such as those in the convolution integral form. Records of the actual strain-time histories are reported herein for proper constitutive modeling.

For each test sample, the cross-sectional area was measured at three locations over a 2 cm length in the middle of the gauge length. The load generated by displacement inputs were measured by a load cell with a capacity approximately 1.5 times the expected maximum load. Load cell output and linearity were calibrated by dead weight. The engineering stress compiled in this report was computed from the measured load divided by the predeformation area.

The in-plane strains were measured by the 350 Ω strain gauges of one of the two configurations shown in Fig. 2. Excitation voltage was nominally 6 volts which, in conjunction with the high resistance strain gauge, was verified to be below the threshold of excessive heating and the associated drift of strain measurements.

Data acquisition for each load and strain channel was performed by individual digital volt meters acting as analogue to digital converters. The sampling rate of the digital volt meters was controlled by a microprocessor which also transfers the digital data and timing signal to a standard magnetic tape. The data on this tape is then transferred to a Digital Equipment LSI-11/60 based data archival and data analysis system.

IV. Data Compilation Procedure

Test data collected in this project were acquired and archived in a computer in digital form. Associated with each sample tested, data was recorded for four or five variables (time, load, $0^{\circ}/90^{\circ}$ strains or $0^{\circ}/45^{\circ}/90^{\circ}$ strains). For each of these variables, approximately 200 points were recorded giving a resolution of 0.5%, roughly corresponding to the accuracies of the instrumentation. Thus, each test sample has 800 to 1000 points, giving a total of 40,000 points for all the specimens. For dissemination of these data, a direct digital print-out is impractical because of the volume of the data involved. On the other hand, a graphical or analogue presentation cannot retain the inherent resolution. A distribution by magnetic tape or disk would be too complex because of the dependency on computer hardware. We have chosen to represent the data by appropriate analytical forms. Compilation of the parameters for the analytical function is a compact method to disseminate and retrieve data. Several analytical forms for data representation were considered. We noted that since the data is associated with time-dependent material characterization, the appropriate analytical

form is governed by the nature of the input function (the ramp in this particular case) and the form of the material constitutive relation (the relaxation function in this case). For example, if we have a constant strain rate input and if we choose the relaxation function to be in the form of an exponential series, then in order to be mathematically consistent, the output function should be the sum of a power series and an exponential series. This can be readily seen by evaluation of the usual convolution integral for viscoelastic materials. However, since the objective of this report is data dissemination, not the formulation of theory for materials characterization, we choose not to limit the flexibility of data utilization by casting the data into a specific choice for the constitutive form. Thus, we compromised on the formalisms of mathematical consistency, and fit both the mechanical input and the materials response output by polynomial series. The degree of the polynomial was chosen to adequately represent the data. The sole intention of polynomial representation is for data compaction and data retrieval. In the theory formulation stage, at the option of the investigator, the data can be represented in other functional forms.

Prior to the data fit, man-machine interactive computer software was used to identify the load and strain datum level to define the zero time and to eliminate extraneous data recorded after failure of the specimen. The operations of this interactive data conditioning are illustrated sequentially from Fig. 3 to Fig. 8. Figure 3 is a typical load versus time record with data taken initially ($t < 4$ seconds) to establish zero load level and extraneous data recorded after failure ($t > 21$ seconds). Figure 4 displays an operator-defined region within which data was considered to be extraneous. Figure 5 displays the region from which data was removed and a new region (on the left) defined by the operator to be enlarged for detailed examination. Figure 6 displays the enlarged region, clearly displaying 16 points taken at zero load for definition of the load datum. Figure 7 displays two operator-defined regions; a

constant was fitted to the region on the left defining the load datum and a polynomial (of an order selected by the operator) was fitted to the right region. The intercept of the two curves defines the zero starting time. Figure 8 displays a replot of the data with the proper datum level and time as defined by the previous steps. For each sample, the zero time defined by the load rise was transferred to the associated strain-versus-time records. In other words, the zero time was not independently determined again for the strain channels of the same specimen.

Our experience indicated that interactive data conditioning was needed; automatic data conditioning algorithms without the heuristics of 'expected' material response frequently are misled by noise in the data and give erroneous representations.

All the test data were conditioned interactively by the above operations. This is followed by a conversion of the physical units of load and deformation voltages into stress and strains. Polynomials were fitted to the stress-versus-time and strain-versus-time records. We noted that a high degree polynomial was needed to adequately represent the data. In Fig. 9 a third degree polynomial was fitted and displayed with the data. We note a good fit over the majority of the data range since the fitted curve (small dots) was completely covered by the data (large dots) except near the origin. An enlargement of the region near the origin shows the discrepancy between the data and the fit. In comparison, a 9th degree polynomial provides a good overall fit, including the origin as shown in Figs. 11 and 12. Accordingly, all data were fitted to 9th degree polynomials and they are presented in the Appendix. The data was compiled for specimens tested at increasing rates of loading. For samples instrumented with two strain gauges there are three graphs, respectively, for stress-versus-time, 0° strain-versus-time, and 90° strain-versus-time. For samples instrumented with a three-gauge rosette, there are four graphs per specimen, the additional graph being 45° strain-versus-time.

The information given on each graph is:

- 1) Type of composite (fiber/epoxy)
- 2) Measured fiber volume
- 3) Nominal loading rate (displacement rate)
- 4) Specimen identification number
- 5) Polynomial fitted to the data
- 6) Actual range of data recorded (in terms of the independent variable)
- 7) Fitted parameters for the polynomials
- 8) Multiple correlation coefficient; $1 \equiv$ perfect fit
- 9) Number of total data points

For clarity, the data was displayed by coarse symbols; whereas, the fitted polynomial was displayed by a dotted curve. A cursory confirmation of satisfactory goodness of fit is suggested when the coarse data points obscure the superimposed fitted curve.

V. Data Retrieval

All the information necessary for retrieving the data are contained with the graphs of the respective variables in the Appendix. The form of the polynomial and the parameters optimized to the data are listed. Also given is the respective actual data range of the independent variable (time) in the polynomial representation. Substitution into the polynomial of time increments within this range assumes the retrieval of the dependent variable (stress or strain) within the accuracy indicated by the multiple correlation coefficient. It should be noted that estimation of the independent variables outside this range constitutes extrapolation from actual data. This should only be done with discretion.

To recapitulate, the objective of this report is to disseminate experimental data of matrix-dominated time-dependent deformation and time-dependent damage in graphite-epoxy composite. The composite

specimens were $\pm 45^\circ$ T300/5208 laminates tested in tension with complete instrumentation for stress, strain, and time recordings. Experimental data was recorded and archived in digital form. Polynomial series are fitted to the experimental data for compilation, dissemination and future retrieval. Data presented herein is accessible to the technical community at large for correlation and the formulation of theory from diverse perspectives, and to meet different goals in fundamental research and engineering applications.

EMW:lvs

0338S

TABLE 1

Testing Matrix for Ramp Loading

<u>Loading Rate</u> cm/min	<u>No. of Specimen</u>	<u>Strain Gauge</u> <u>Instrumentation</u>	
		<u>0/90</u>	<u>0/45/90</u>
0.0001	10	8	2
0.0100	10	8	2
1.0000	10	9	1

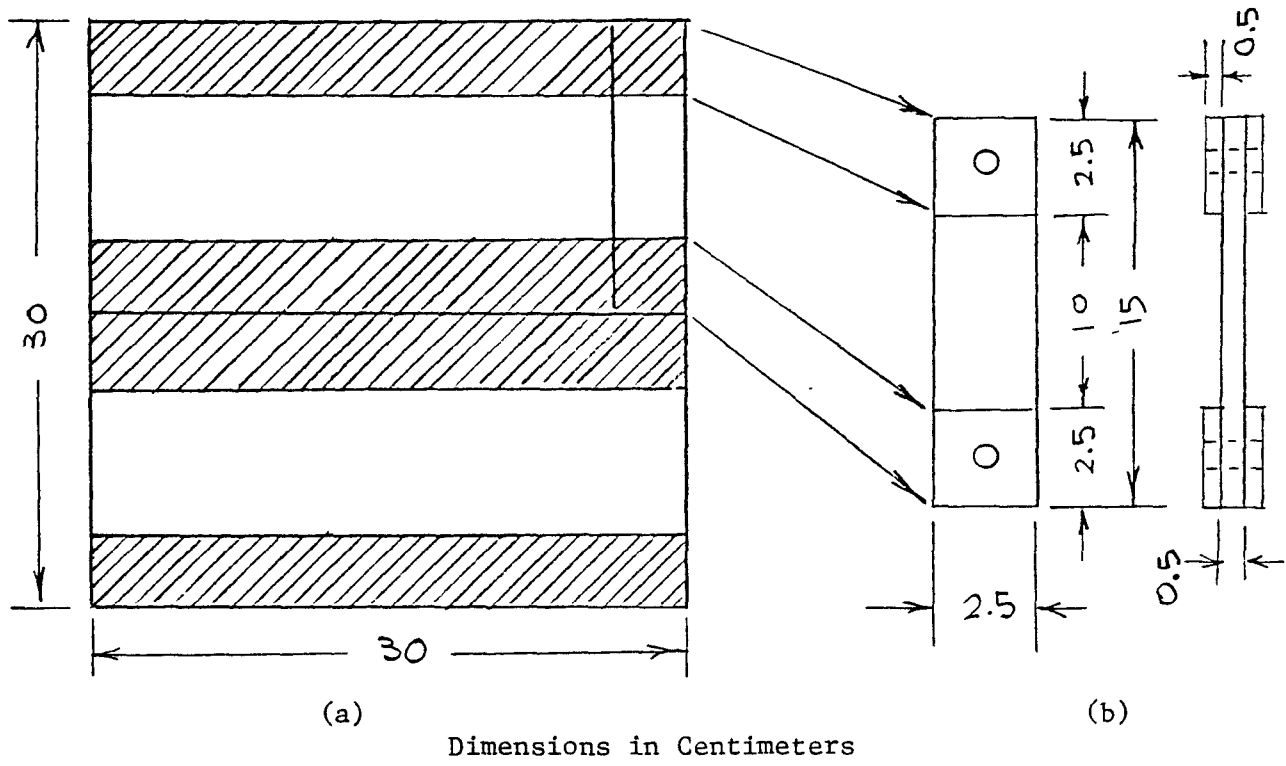

Fig. 1: (a) Laminate with glass-cloth reinforced tab material (shaded regions)
 (b) Coupon dimension and configuration

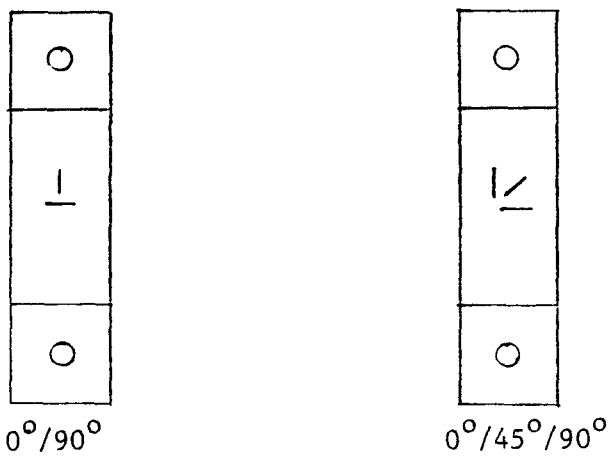

Fig. 2: Strain gauge configurations for test coupons

T300/5208 - VF=61.8 - 1 CM/MIN

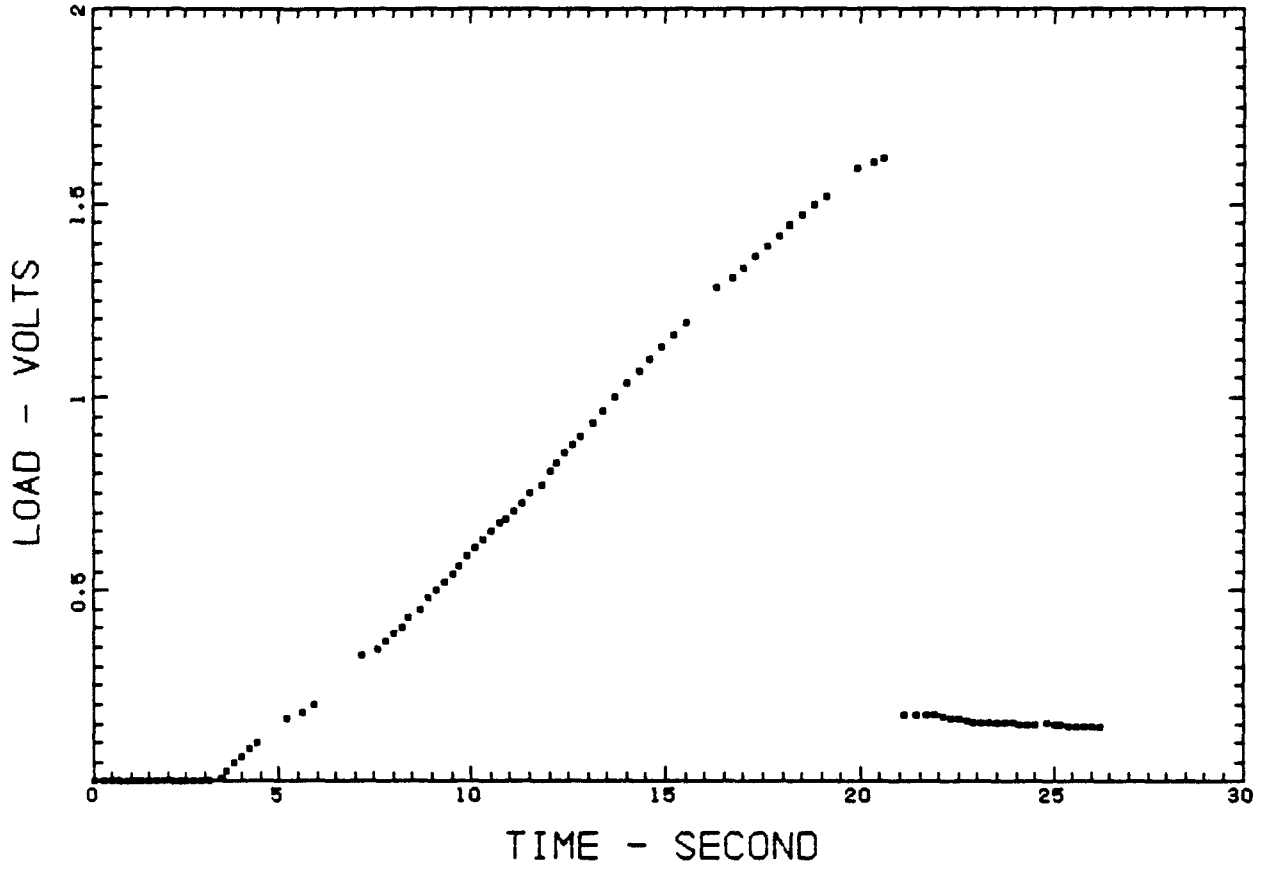

Fig. 3 - Typical data before man-machine interactive data conditioning.

T300/5208 - VF=61.8 - 1 CM/MIN

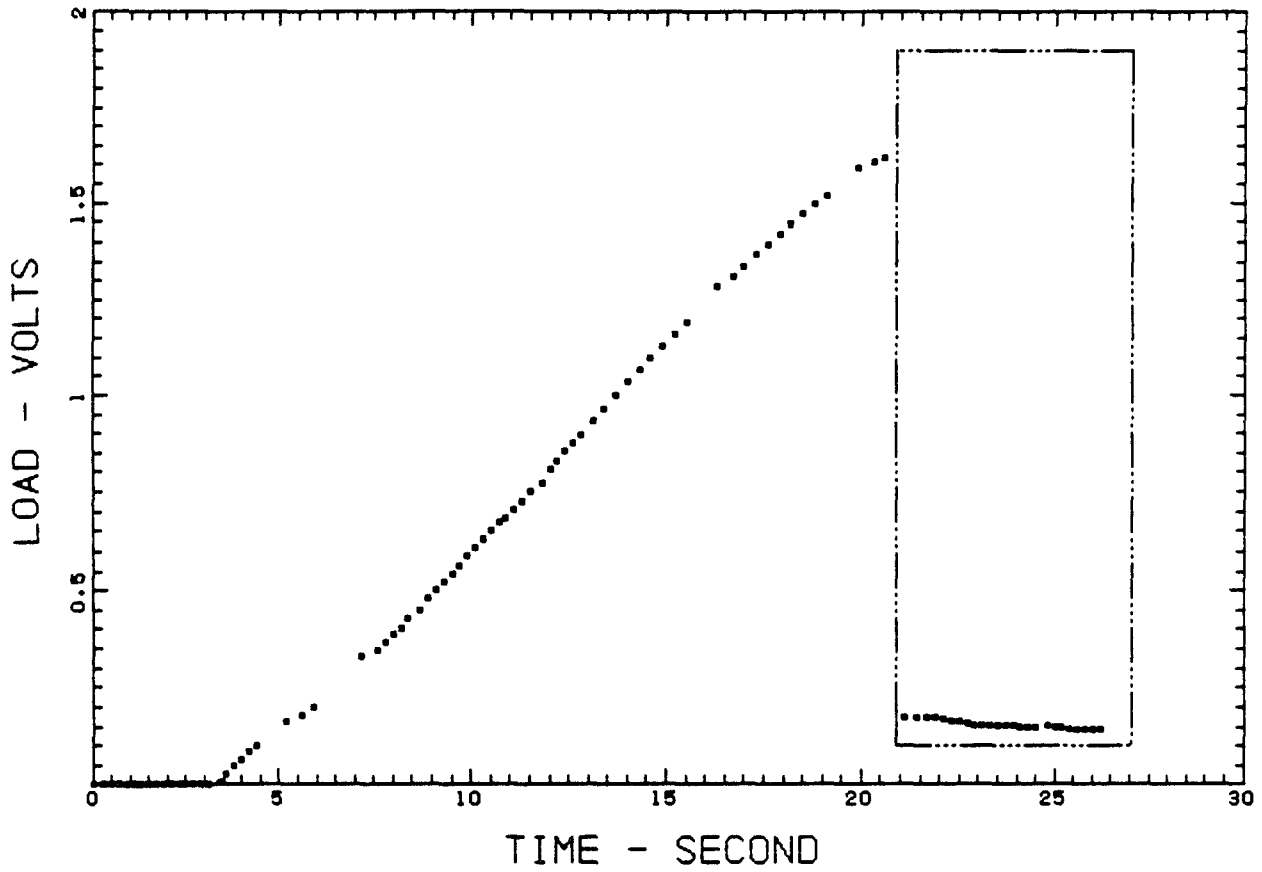

Fig. 4 - Elimination of extraneous data recorded after specimen failure.

T300/5208 - VF=61.8 - 1 CM/MIN

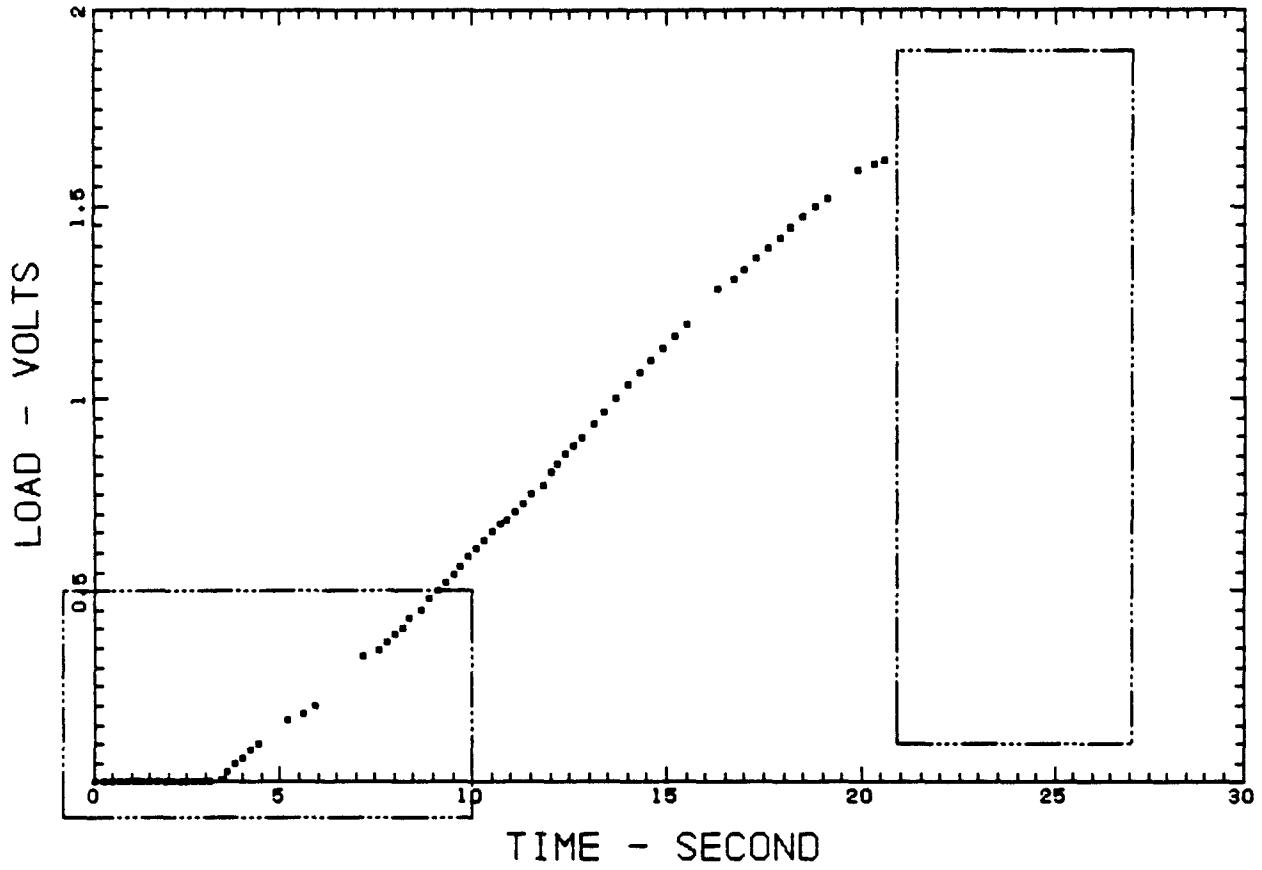

Fig. 5 - Extraneous data removed and definition of zone for enlargement.

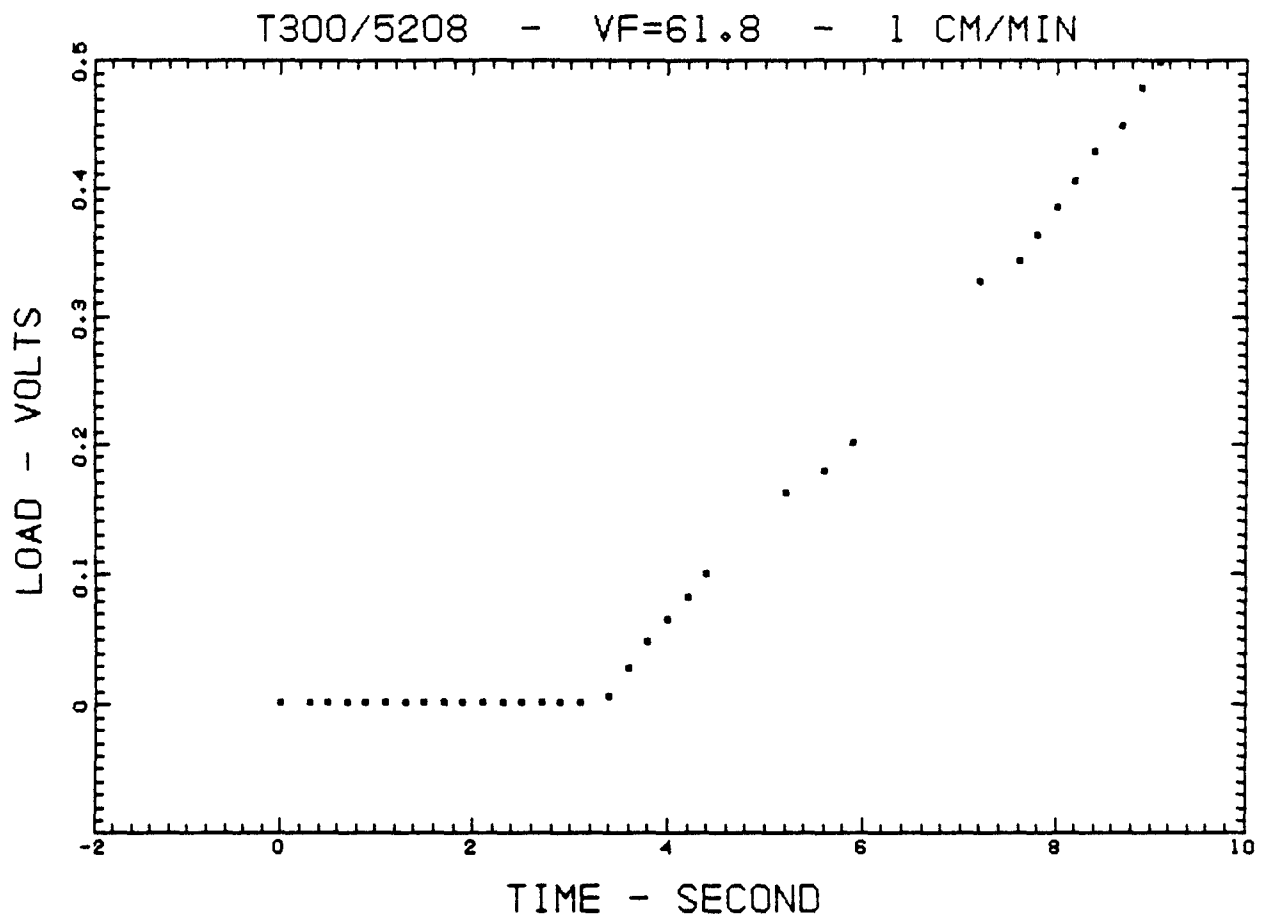

Fig. 6 - Enlarged zone as defined.

T300/5208 - VF=61.8 - 1 CM/MIN

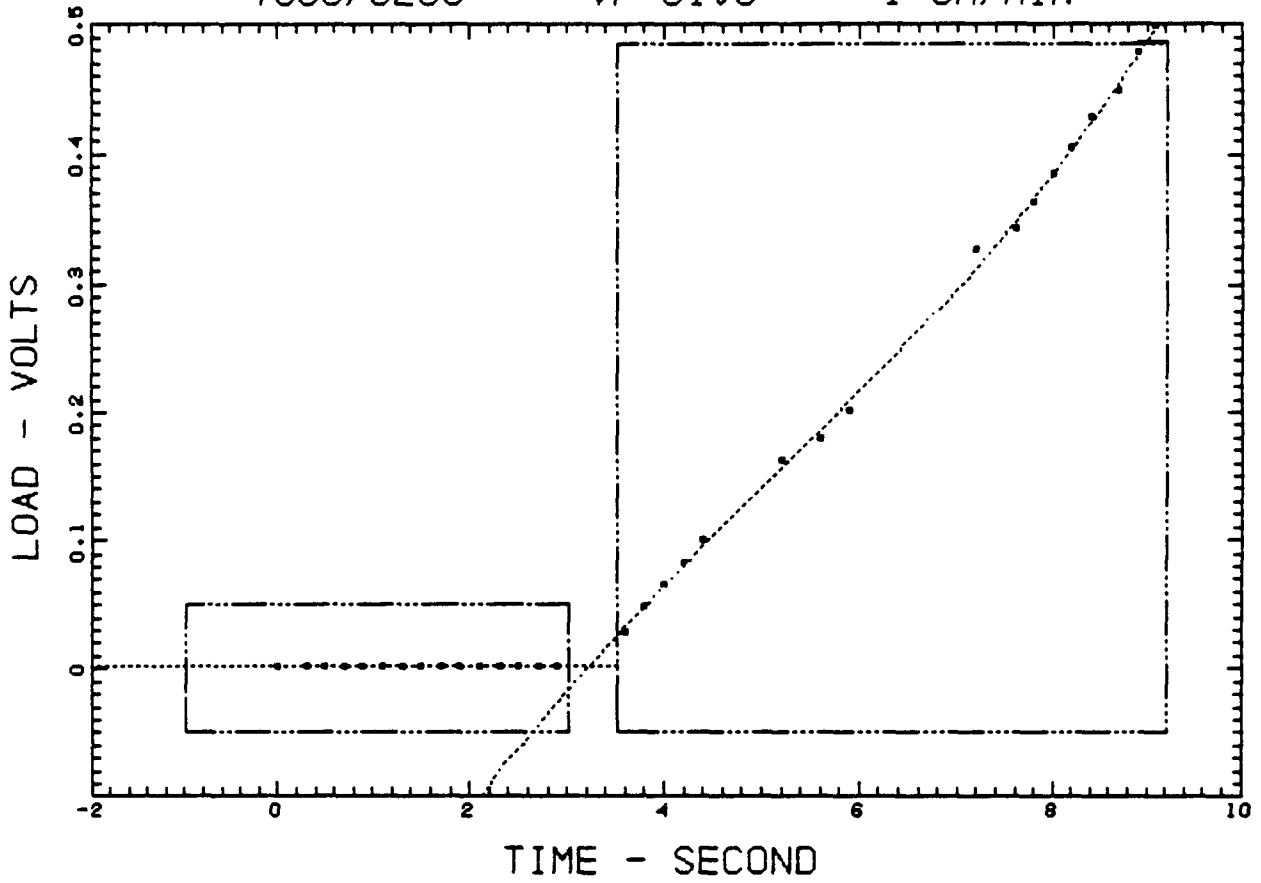

Fig. 7 - Fit of curves in defined zones to identify load datum and zero time.

T300/5208 - VF=61.8 - 1 CM/MIN

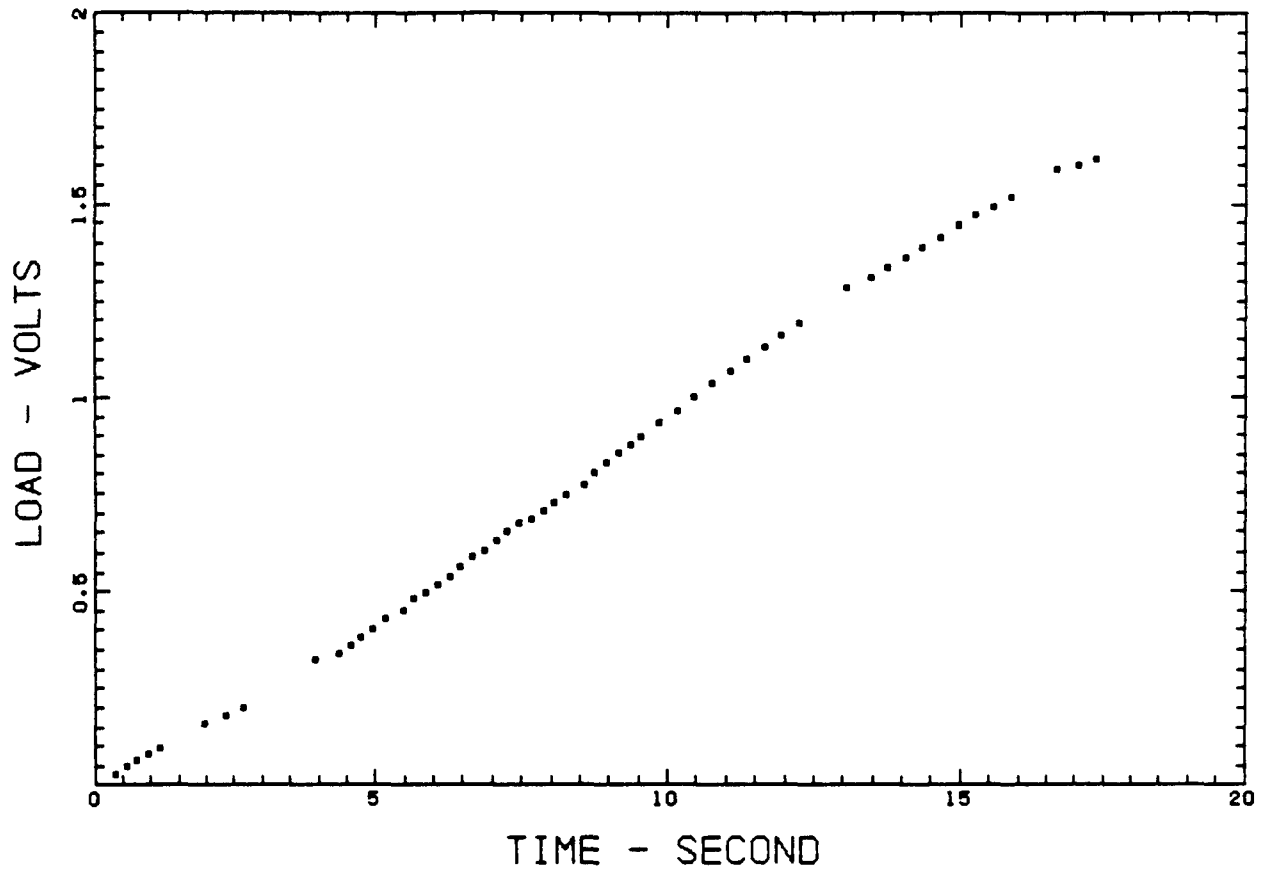

Fig. 8 - Conditioned data at corrected load datum, zero time and width extraneous data removed.

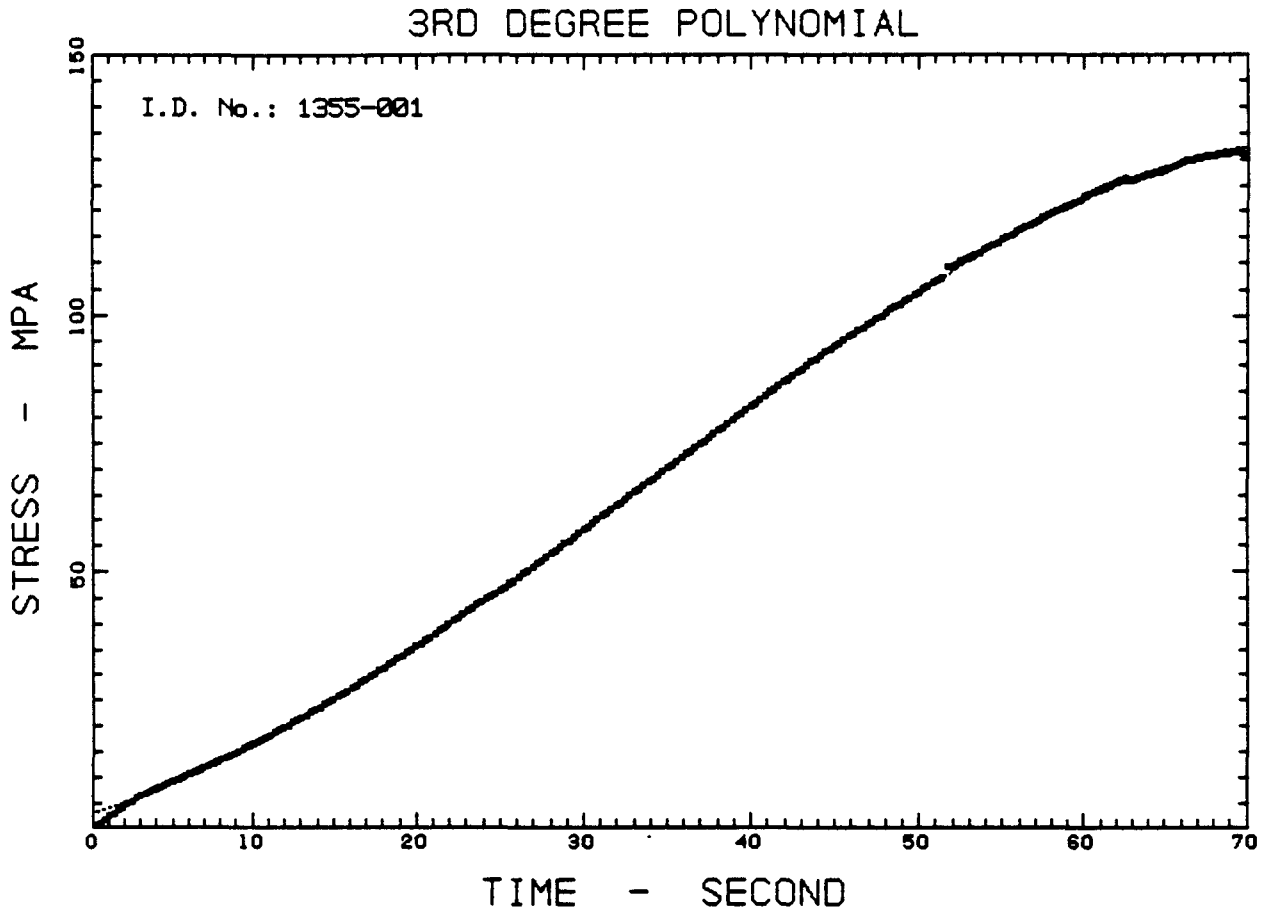

Fig. 9 - Typical data fitted to 3rd degree polynomial. Note discrepancy around origin.

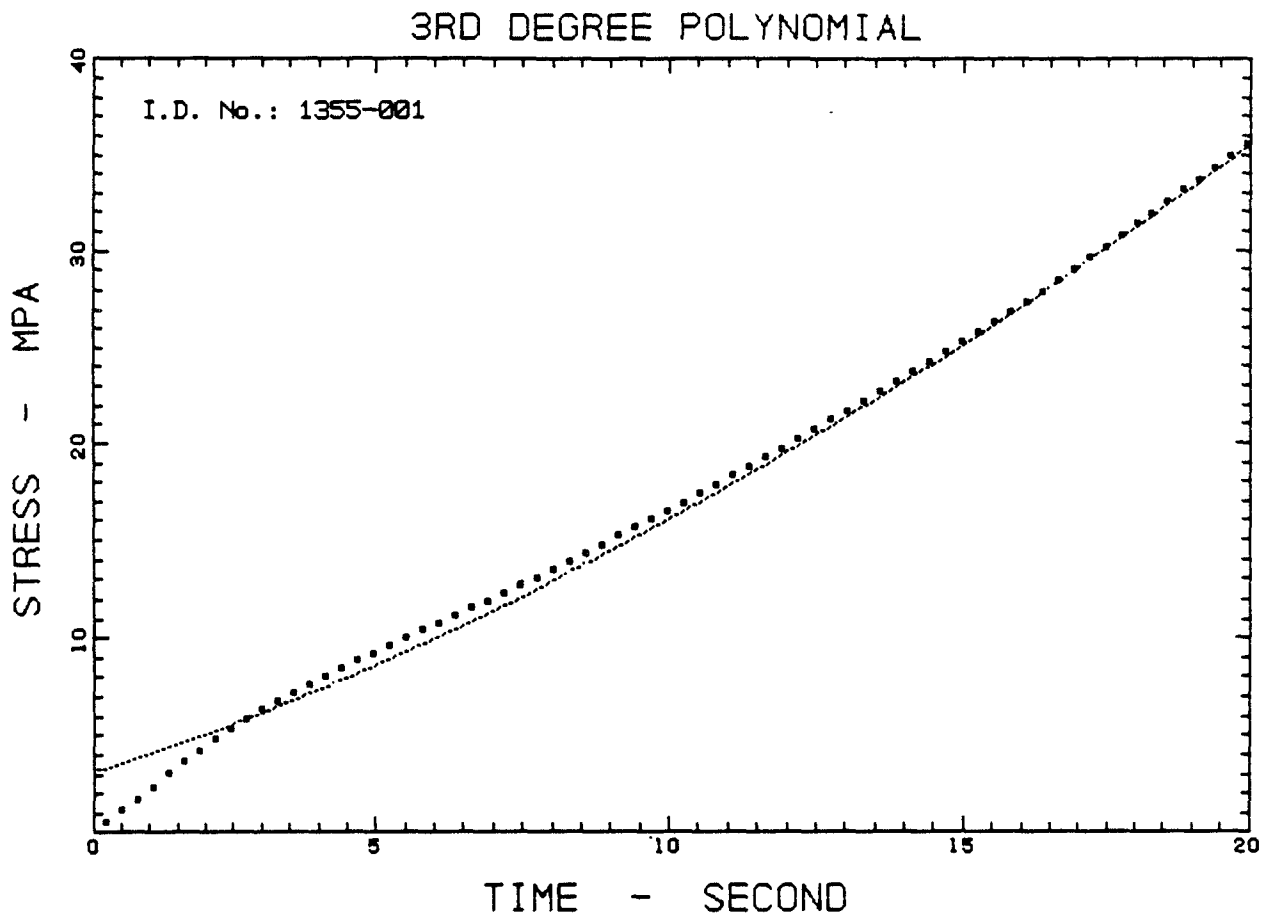

Fig. 10 - Enlargement of discrepancy of fit at the origin.

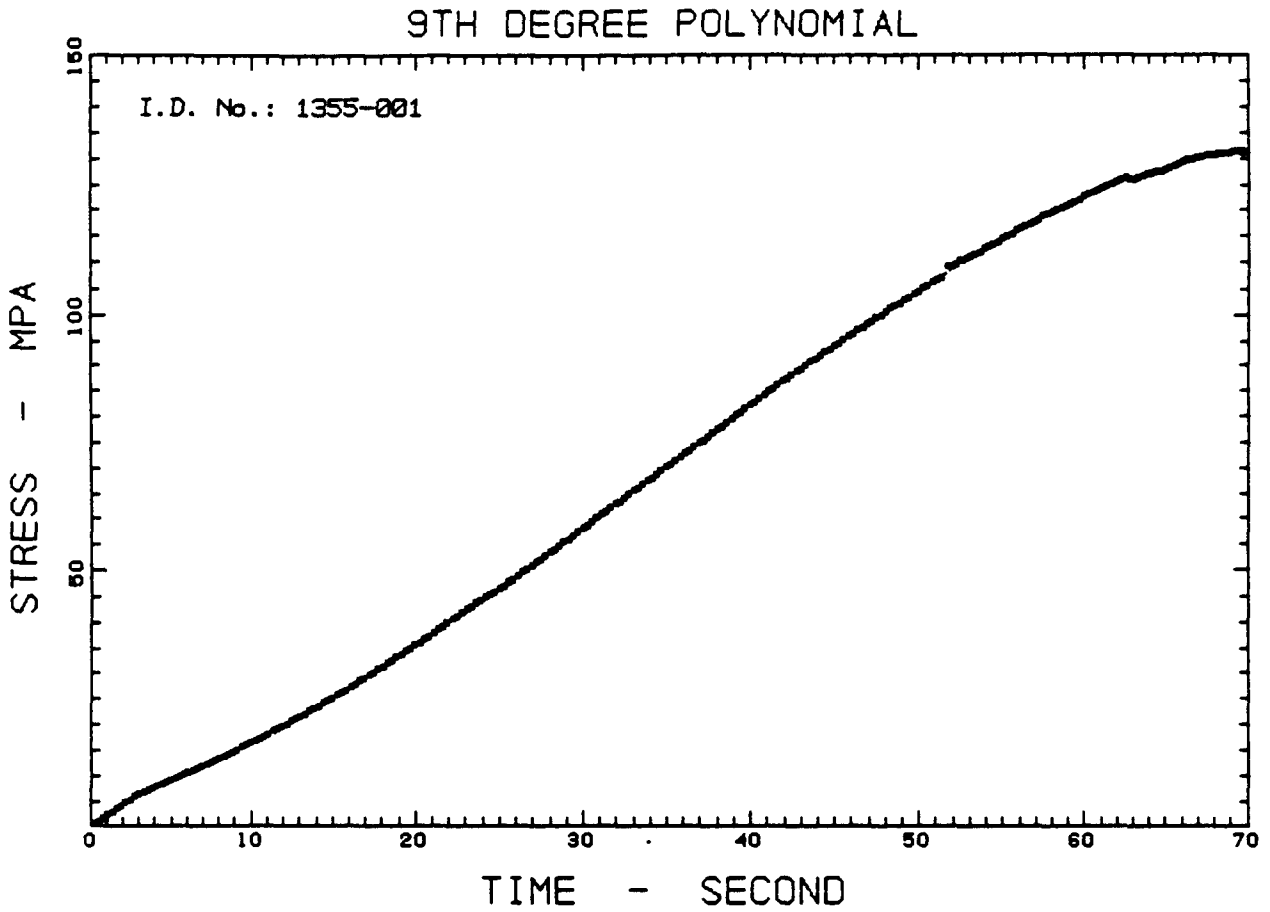

Fig. 11 - Same data fitted to 9th degree polynomial. No visible discrepancies over entire range.

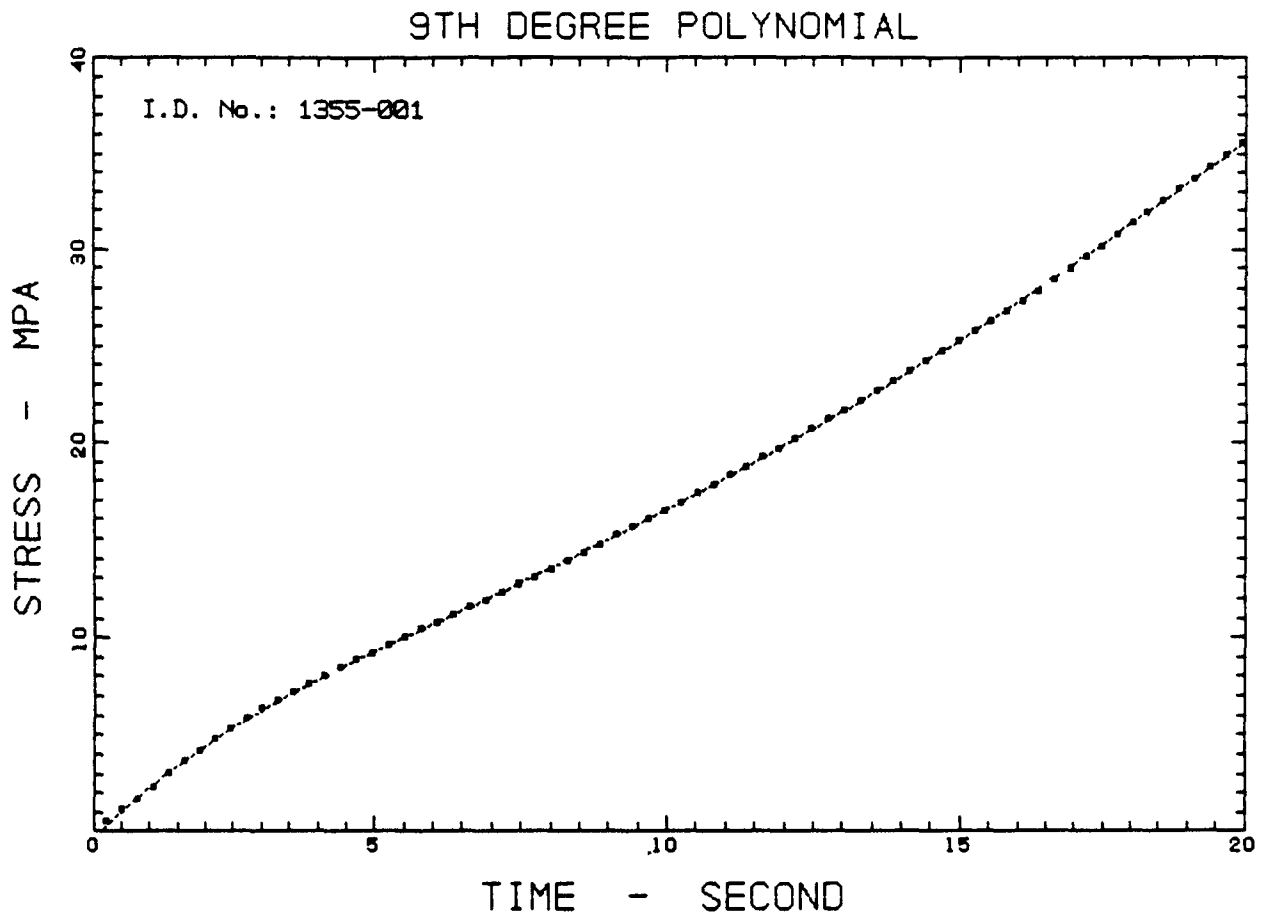

Fig. 12 - Enlarged region near origin confirming fine fit.

APPENDIX: Experimental Data Under Ramp Loading

Specimen I.D.	TIME (Hours)	STRESS (MPa)	0-Degree Strain (%)	90-Degree Strain (%)
1355-001	0.24 - 69.68	0.56 - 131.4	0.001 - 1.52	0.001 - 1.26
1355-002	0.29 - 51.40	0.43 - 126.0	0.003 - 1.31	0.001 - 1.05
1358-001	3.97 - 60.36	6.80 - 130.2	0.034 - 1.38	0.024 - 1.15
1358-002	0.29 - 53.06	0.50 - 136.8	0.003 - 1.74	0.001 - 1.66
1359-001	0.22 - 66.60	1.37 - 129.8	0.003 - 1.46	0.003 - 1.26
1359-002	0.18 - 55.18	1.54 - 134.7	0.007 - 1.83	0.004 - 1.69
1359-003	0.17 - 71.55	1.29 - 136.2	0.001 - 2.06	0.003 - 1.82
1359-004	0.16 - 58.21	1.29 - 141.2	0.006 - 2.09	0.007 - 1.82
1363-005	0.17 - 51.28	1.01 - 136.5	0.004 - 1.96	0.003 - 1.69 *
1363-006	0.07 - 58.67	0.46 - 142.9	0.003 - 2.19	0.002 - 2.10 *
(Minutes)				
1356-001	0.23 - 35.23	0.85 - 146.9	0.002 - 1.45	0.002 - 1.18
1356-002	0.96 - 23.96	4.52 - 132.3	0.019 - 0.99	0.017 - 0.84
1356-003	1.71 - 31.87	5.74 - 142.8	0.025 - 1.25	0.019 - 0.95
1356-004	0.40 - 31.90	0.92 - 151.9	0.005 - 1.55	0.004 - 1.24
1356-005	0.38 - 33.21	1.35 - 137.8	0.000 - 1.24	0.002 - 0.97
1356-006	0.08 - 29.58	0.27 - 148.5	0.001 - 1.45	0.001 - 1.18
1362-001	0.17 - 31.01	2.31 - 147.6	0.013 - 1.92	0.006 - 1.63
1362-002	0.05 - 30.88	0.88 - 141.2	0.005 - 1.83	0.004 - 1.56
1363-001	0.14 - 29.47	1.72 - 145.2	0.009 - 1.67	0.007 - 1.46 *
1363-002	0.05 - 31.72	0.73 - 141.9	0.004 - 1.72	0.002 - 1.45 *
(Seconds)				
1357-001	0.61 - 17.61	2.75 - 152.4	0.013 - 1.25	0.010 - 0.99
1357-002	0.61 - 19.01	2.44 - 165.4	0.010 - 1.38	0.007 - 1.15
1357-003	0.17 - 17.97	1.35 - 156.1	0.005 - 1.27	0.004 - 1.05
1357-004	1.51 - 21.81	4.68 - 152.3	0.023 - 1.42	0.018 - 1.10
1362-003	0.23 - 15.73	7.06 - 160.6	0.036 - 1.63	0.025 - 1.38
1362-004	0.24 - 17.74	6.87 - 170.4	0.033 - 1.64	0.025 - 1.43
1362-005	0.28 - 18.28	7.07 - 167.6	0.039 - 1.87	0.027 - 1.47
1362-006	0.36 - 17.86	7.82 - 166.1	0.036 - 1.61	0.027 - 1.38
1363-003	0.16 - 16.66	4.01 - 165.0	0.018 - 1.69	1.452 - 0.01
1363-004	0.23 - 16.73	5.77 - 163.5	0.029 - 1.65	0.019 - 1.33 *

* Instrumented with 0°/45°/90° Strain Gauge Rosette

T300/5208 - VF=61.8 - 0.0001 CM/MIN

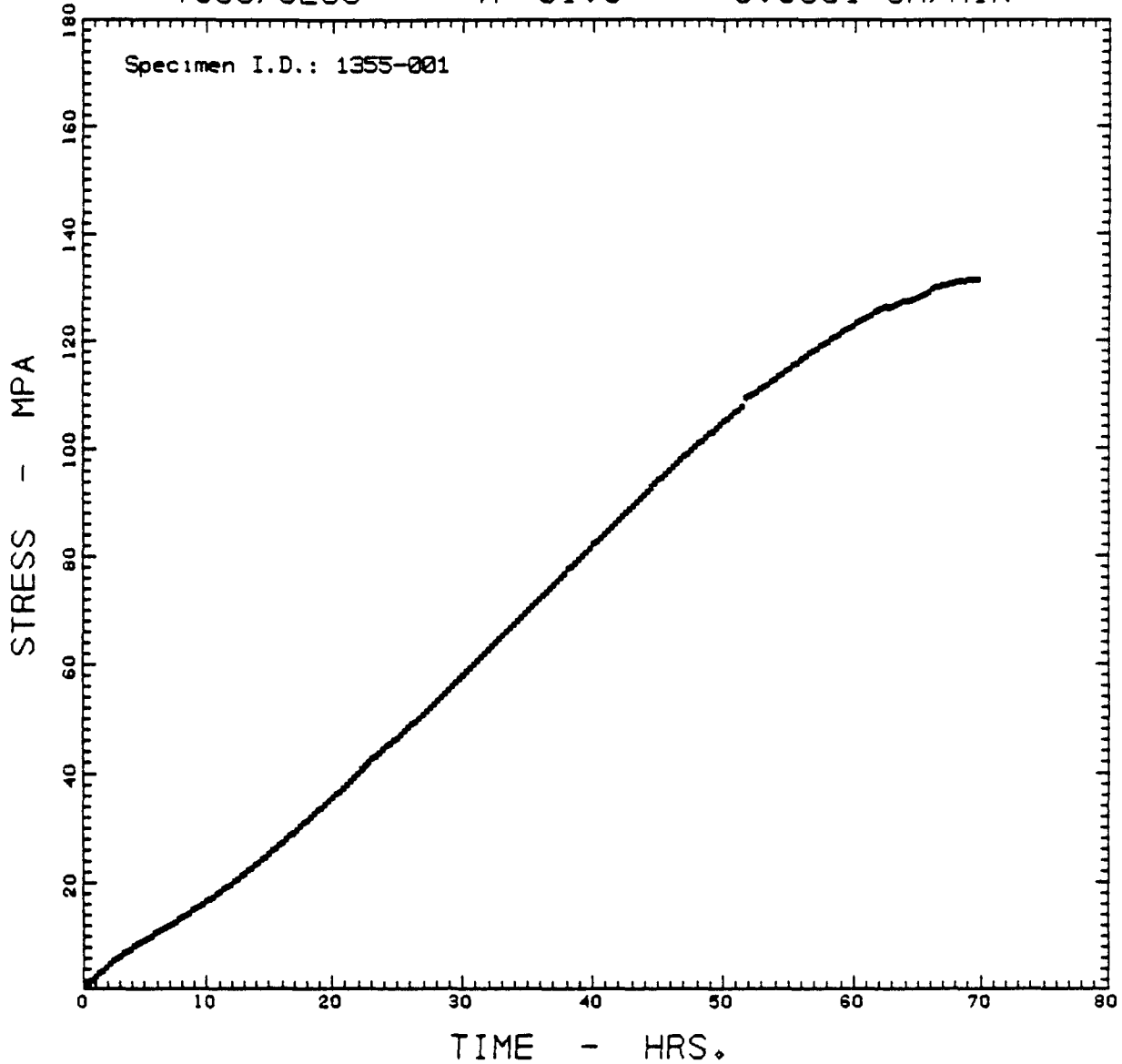

$$\text{STRESS} = A_0 + A_1 \cdot \text{TIME} + A_2 \cdot \text{TIME}^2 + \dots + A_9 \cdot \text{TIME}^9$$

where:

$$0.2417 \leq \text{TIME} \leq 69.6792$$

A0 = -0.3103E+00	A4 = -0.2140E-02	A7 = 0.1876E-07
A1 = 0.2958E+01	A5 = 0.7215E-04	A8 = -0.1297E-09
A2 = -0.3531E+00	A6 = -0.1499E-05	A9 = 0.3809E-12
A3 = 0.3807E-01		

Multiple Correlation Coefficient = 0.999988; No. of Data Points = 251

T300/5208 - VF=61.8 - 0.0001 CM/MIN

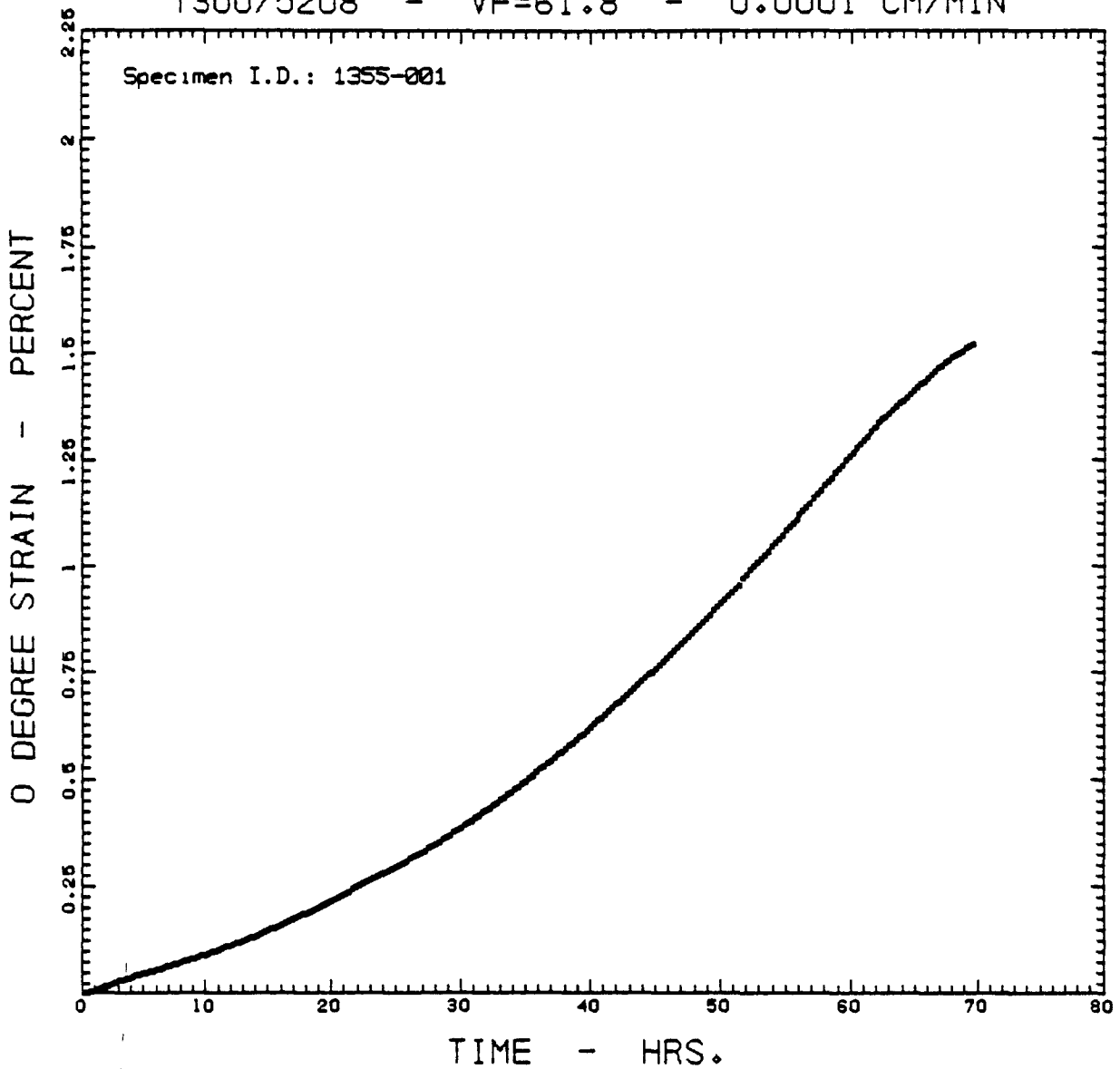

$$\text{STRAIN} = A_0 + A_1 \cdot \text{TIME} + A_2 \cdot \text{TIME}^2 + \dots + A_9 \cdot \text{TIME}^9$$

where:

$$0.2417 \leq \text{TIME} \leq 69.6792$$

A0 = -0.6270E-02	A4 = -0.1525E-04	A7 = 0.1719E-09
A1 = 0.1620E-01	A5 = 0.5657E-06	A8 = -0.1266E-11
A2 = -0.2038E-02	A6 = -0.1277E-07	A9 = 0.3912E-14
A3 = 0.2465E-03		

Multiple Correlation Coefficient = 0.999994; No. of Data Points = 251

T300/5208 - VF=61.8 - 0.0001 CM/MIN

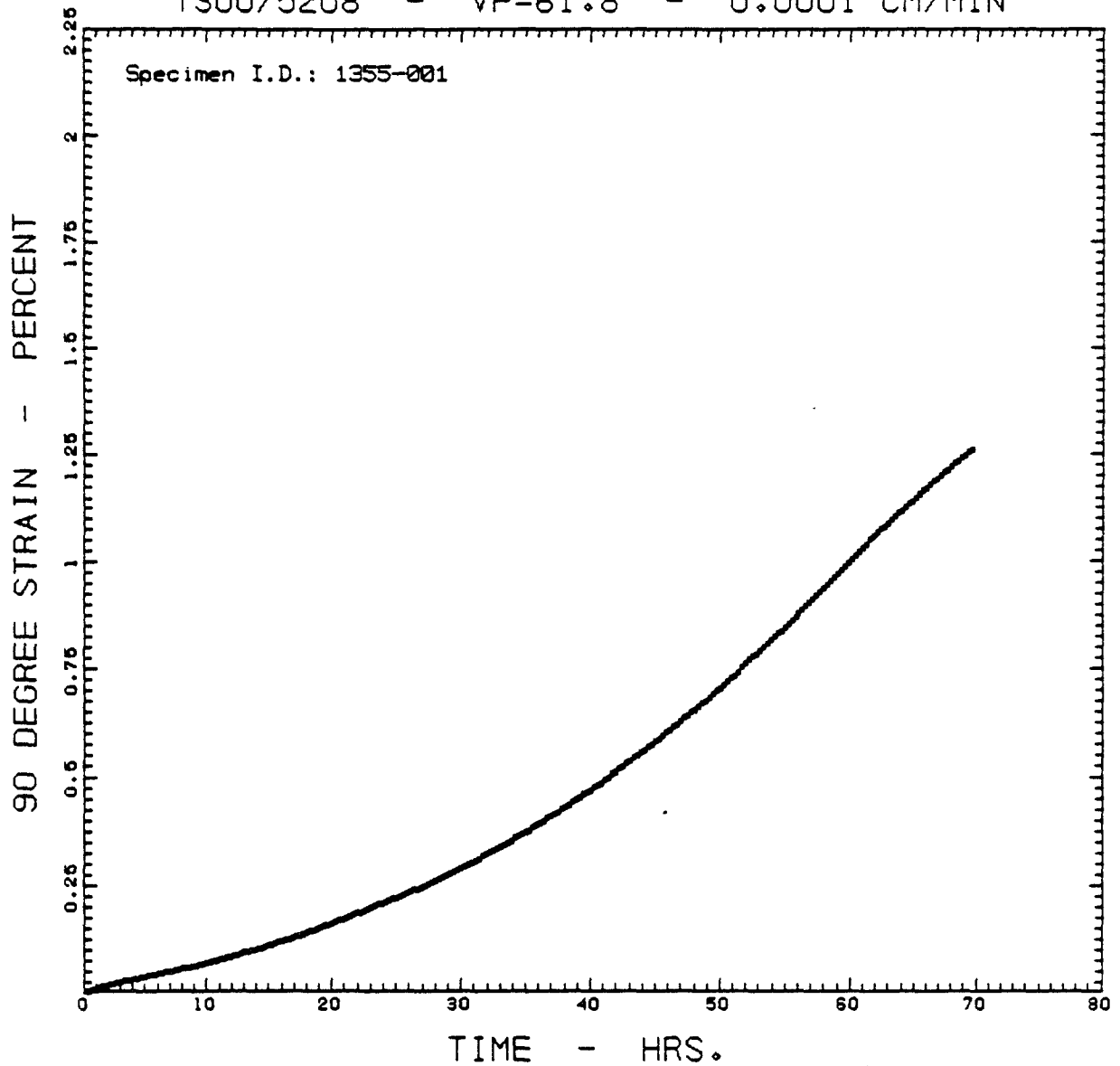

$$\text{STRAIN} = A_0 + A_1 \cdot \text{TIME} + A_2 \cdot \text{TIME}^2 + \dots + A_9 \cdot \text{TIME}^9$$

where:

$$0.2417 \leq \text{TIME} \leq 69.6792$$

$$A_0 = -0.3839E-02$$

$$A_1 = 0.1318E-01$$

$$A_2 = -0.1871E-02$$

$$A_3 = 0.2253E-03$$

$$A_4 = -0.1401E-04$$

$$A_5 = 0.5226E-06$$

$$A_6 = -0.1188E-07$$

$$A_7 = 0.1613E-09$$

$$A_8 = -0.1199E-11$$

$$A_9 = 0.3744E-14$$

Multiple Correlation Coefficient = 0.999994; No. of Data Points = 251

T300/5208 - VF=61.8 - 0.0001 CM/MIN

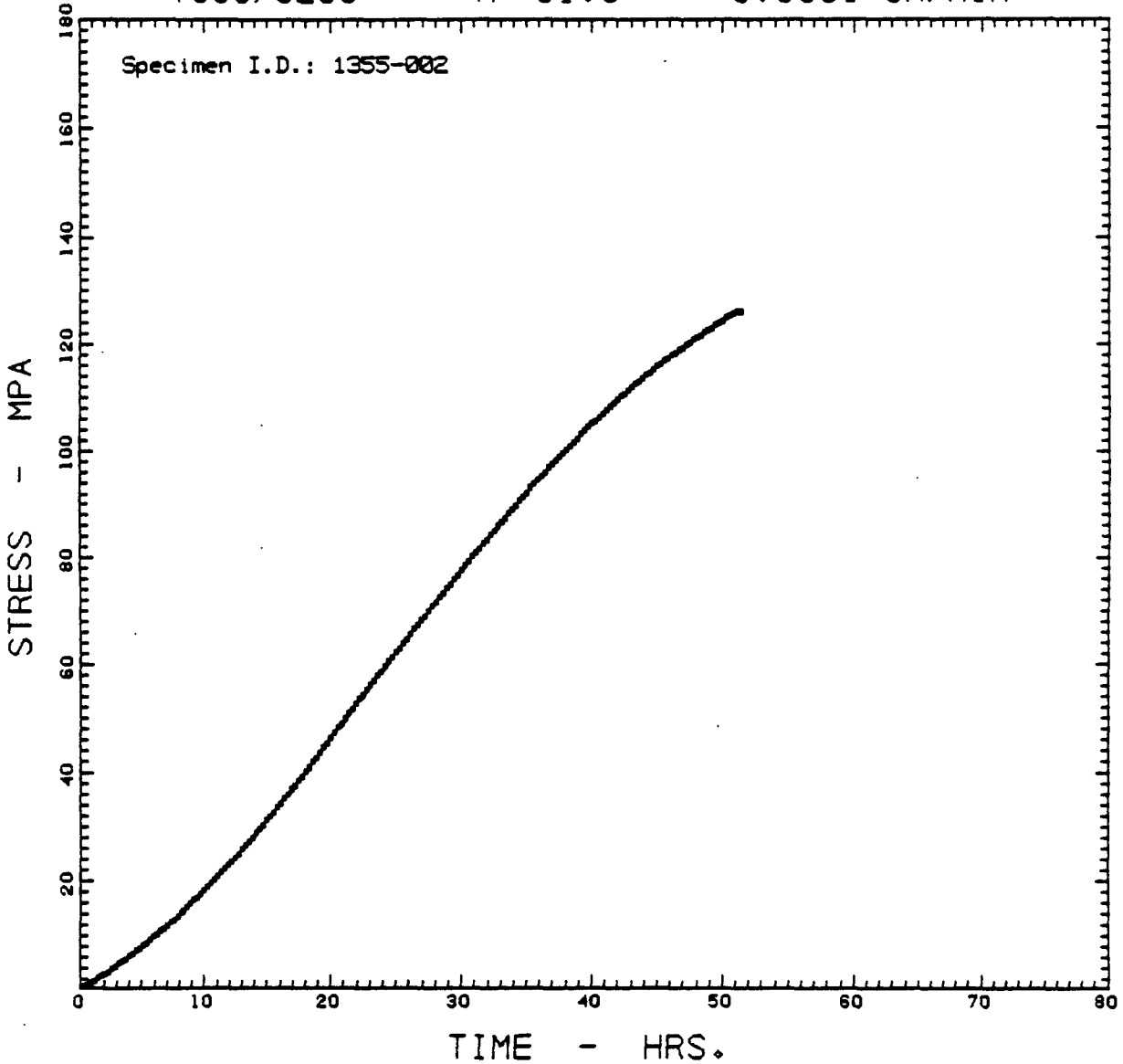

$$\text{STRESS} = A_0 + A_1 \cdot \text{TIME} + A_2 \cdot \text{TIME}^2 + \dots + A_9 \cdot \text{TIME}^9$$

where:

$$0.2928 \leq \text{TIME} \leq 51.3988$$

A0 = 0.1241E+00	A4 = 0.3458E-02	A7 = -0.1182E-06
A1 = 0.1125E+01	A5 = -0.1956E-03	A8 = 0.1192E-08
A2 = 0.1945E+00	A6 = 0.6323E-05	A9 = -0.5019E-11
A3 = -0.3285E-01		

Multiple Correlation Coefficient = 0.999999; No. of Data Points = 185

T300/5208 - VF=61.8 - 0.0001 CM/MIN

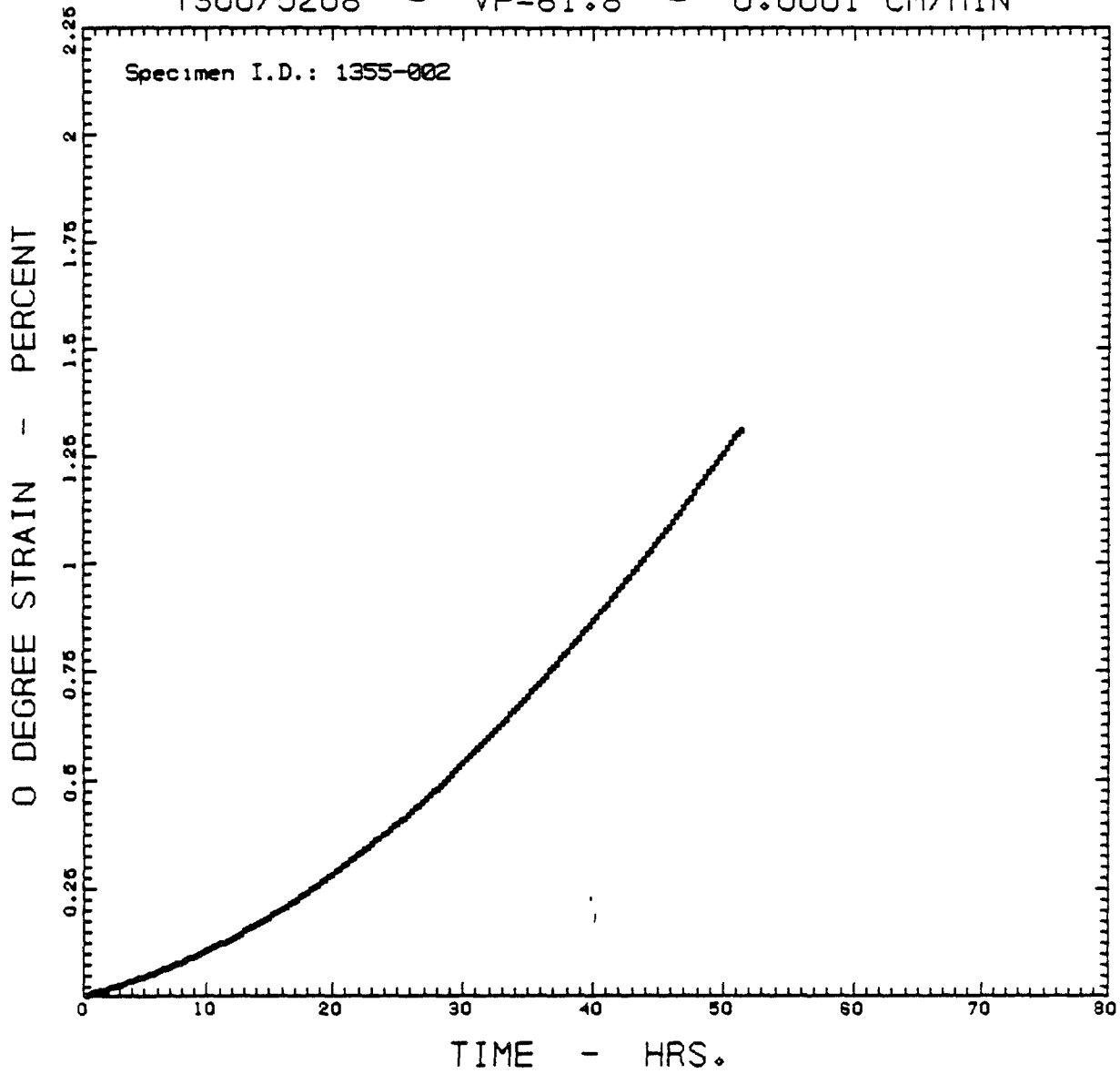

$$\text{STRAIN} = A_0 + A_1 \cdot \text{TIME} + A_2 \cdot \text{TIME}^2 + \dots + A_9 \cdot \text{TIME}^9$$

where:

$$0.2928 \leq \text{TIME} \leq 51.3988$$

A0 = 0.1771E-02	A4 = 0.1805E-04	A7 = -0.7395E-09
A1 = 0.7518E-02	A5 = -0.1093E-05	A8 = 0.7806E-11
A2 = 0.7795E-03	A6 = 0.3751E-07	A9 = -0.3422E-13
A3 = -0.1512E-03		

Multiple Correlation Coefficient = 0.999999; No. of Data Points = 185

T300/5208 - VF=61.8 - 0.0001 CM/MIN

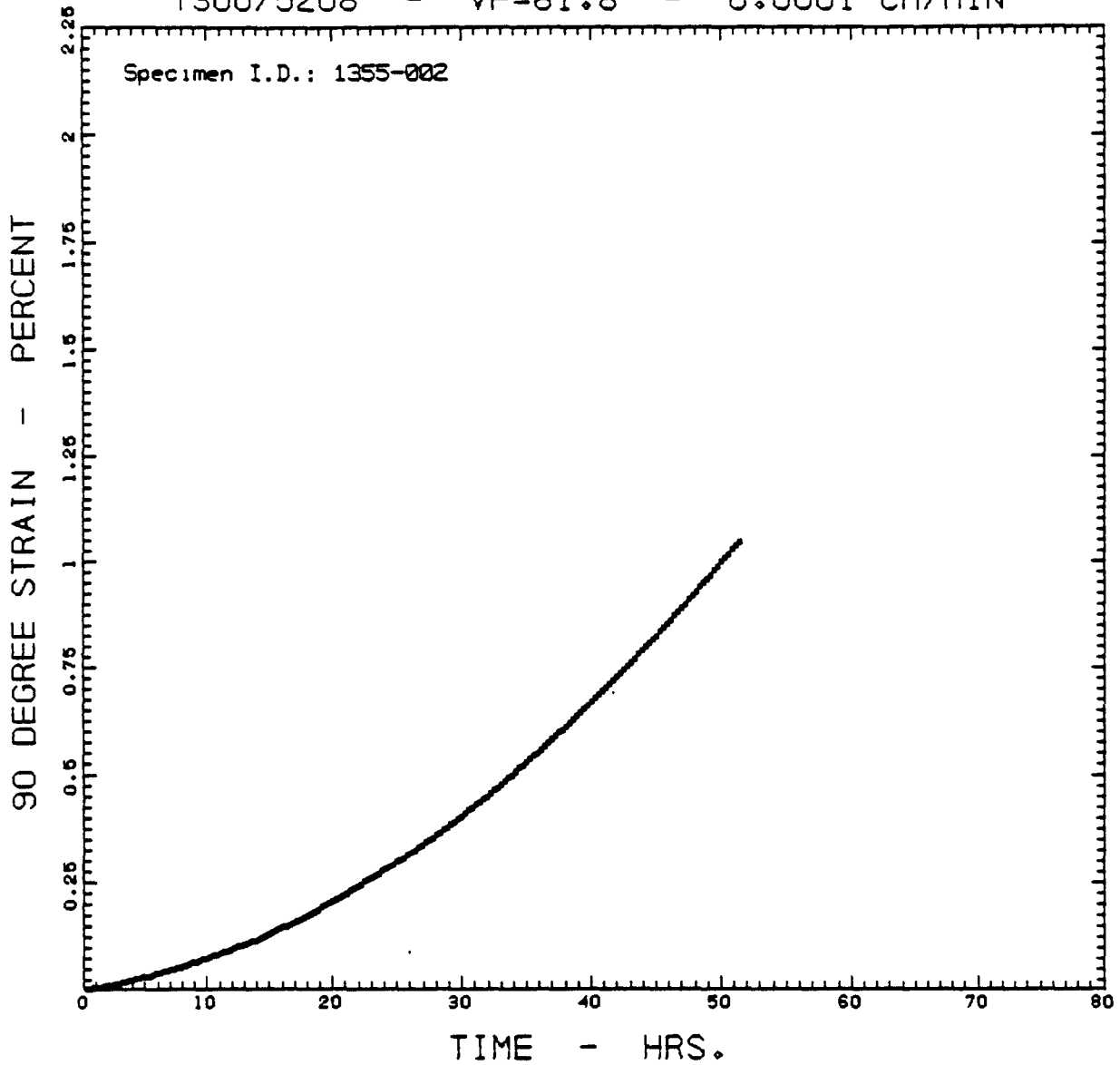

STRAIN = A0 + A1*TIME + A2*TIME^2 + ... + A9*TIME^9

where:

0.2928 < TIME < 51.3988

A0 = 0.3619E-03

A1 = 0.3707E-02

A2 = 0.9472E-03

A3 = -0.1471E-03

A4 = 0.1485E-04

A5 = -0.8156E-06

A6 = 0.2618E-07

A7 = -0.4908E-09

A8 = 0.4983E-11

A9 = -0.2118E-13

Multiple Correlation Coefficient = 0.999999; No. of Data Points = 185

T300/5208 - VF=61.8 - 0.0001 CM/MIN

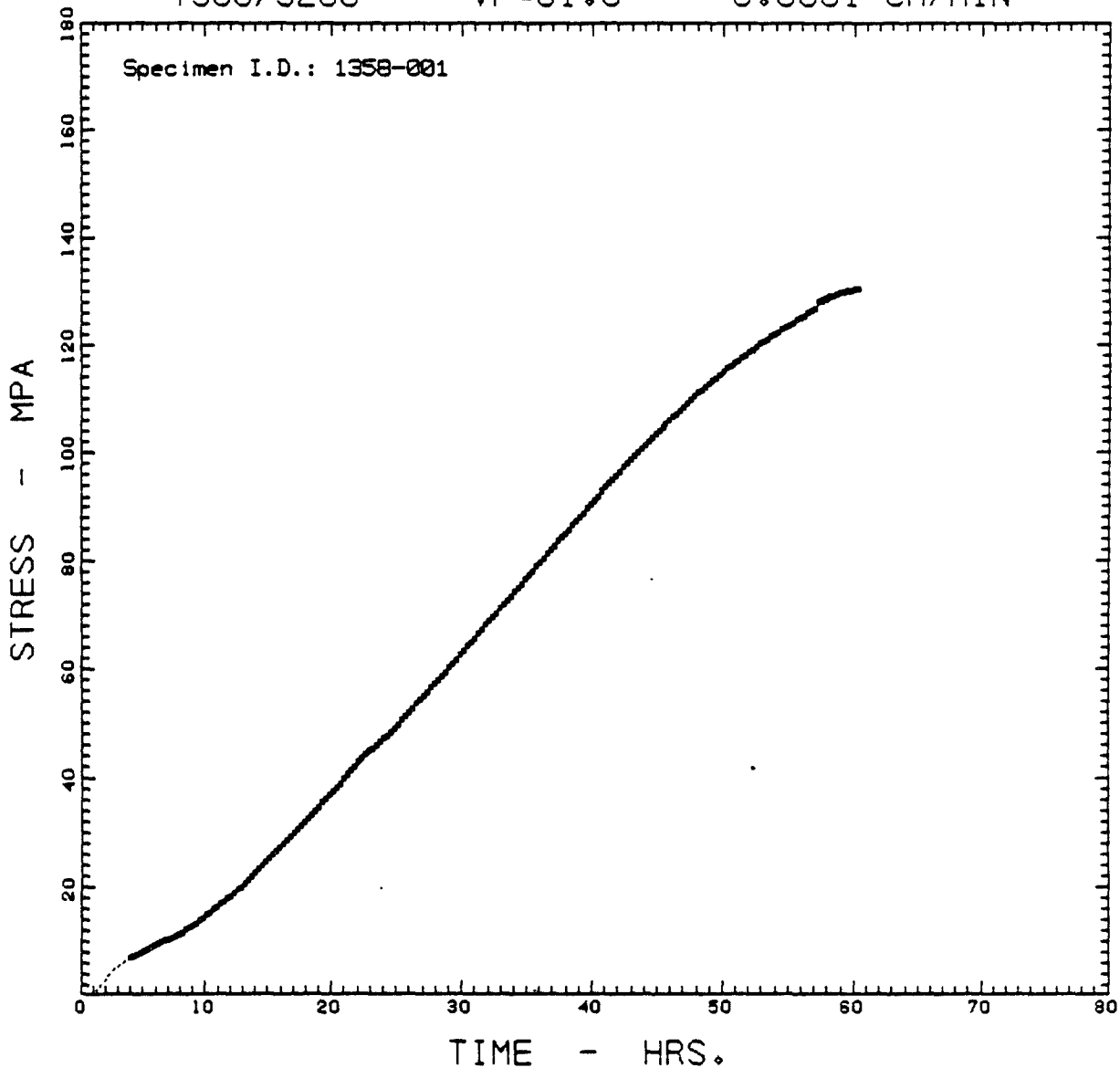

$$\text{STRESS} = A_0 + A_1 \cdot \text{TIME} + A_2 \cdot \text{TIME}^2 + \dots + A_9 \cdot \text{TIME}^9$$

where:

3.9719 < TIME < 60.3552

A0 = -0.4705E+01	A4 = -0.8379E-02	A7 = 0.8850E-07
A1 = 0.5774E+01	A5 = 0.3054E-03	A8 = -0.6339E-09
A2 = -0.1145E+01	A6 = -0.6743E-05	A9 = 0.1905E-11
A3 = 0.1352E+00		

Multiple Correlation Coefficient = 0.999982; No. of Data Points = 204

T300/5208 - VF=61.8 - 0.0001 CM/MIN

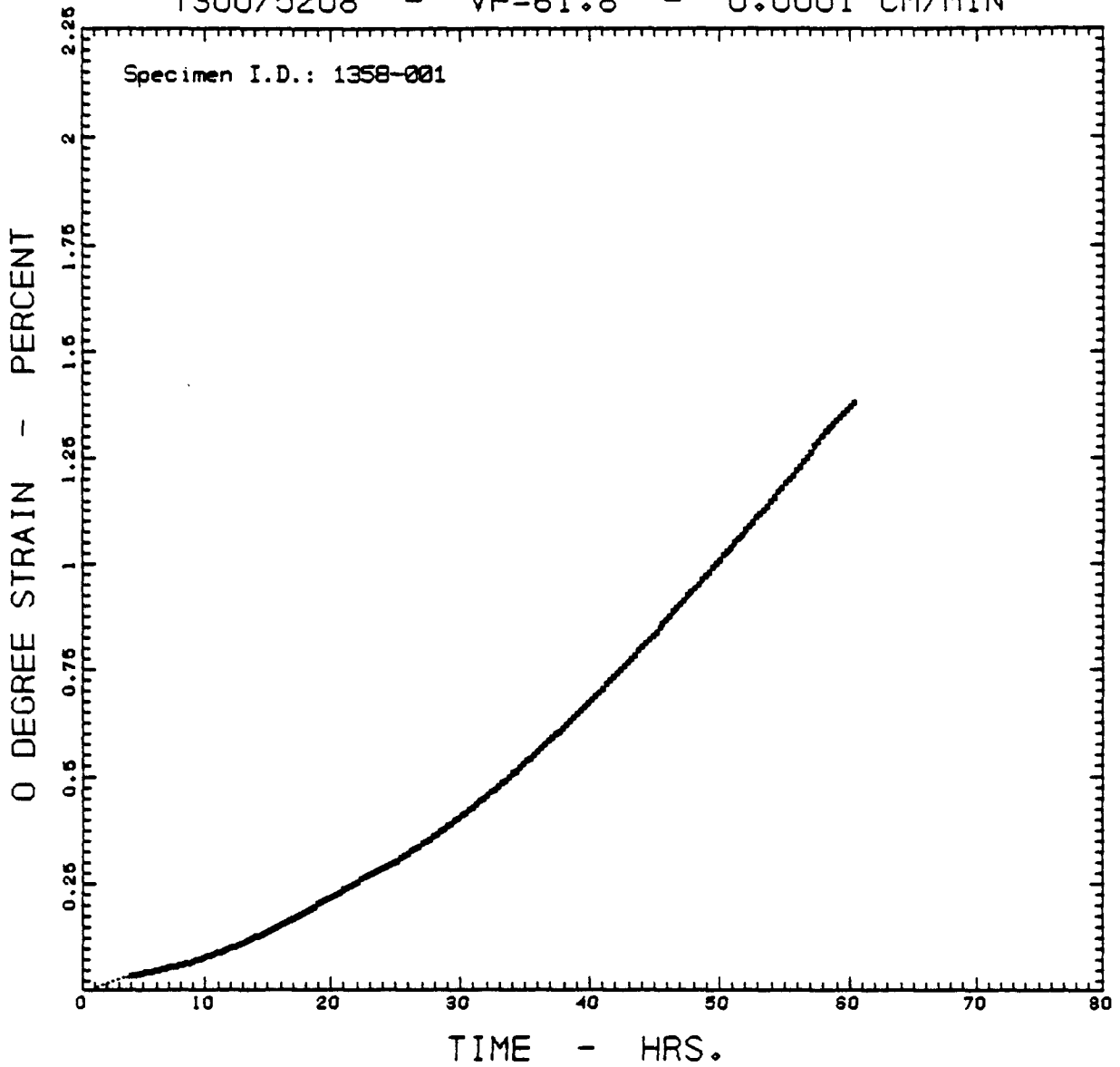

$$\text{STRAIN} = A_0 + A_1 \cdot \text{TIME} + A_2 \cdot \text{TIME}^2 + \dots + A_9 \cdot \text{TIME}^9$$

where:

$$3.9719 \leq \text{TIME} \leq 60.3552$$

A0 = -0.1201E-01	A4 = -0.2233E-04	A7 = 0.5665E-10
A1 = 0.2096E-01	A5 = 0.6547E-06	A8 = 0.2365E-12
A2 = -0.3643E-02	A6 = -0.9927E-08	A9 = -0.3063E-14
A3 = 0.4129E-03		

Multiple Correlation Coefficient = 0.999987; No. of Data Points = 204

T300/5208 - VF=61.8 - 0.0001 CM/MIN

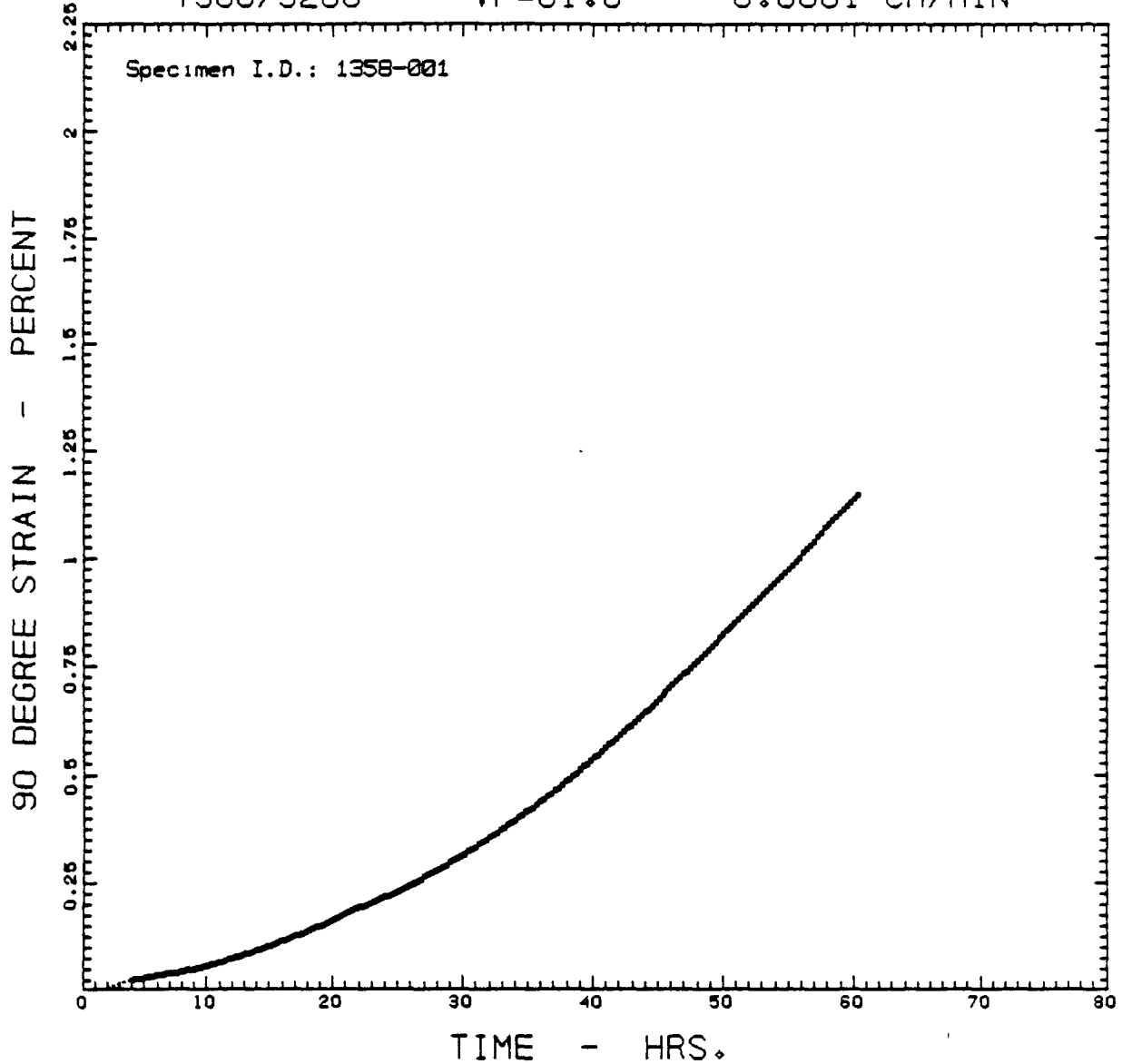

$$\text{STRAIN} = A_0 + A_1 \cdot \text{TIME} + A_2 \cdot \text{TIME}^2 + \dots + A_9 \cdot \text{TIME}^9$$

where:

$$3.9719 \leq \text{TIME} \leq 60.3552$$

A0 = -0.3392E-01	A4 = -0.4018E-04	A7 = 0.4415E-09
A1 = 0.2906E-01	A5 = 0.1470E-05	A8 = -0.3284E-11
A2 = -0.5721E-02	A6 = -0.3286E-07	A9 = 0.1041E-13
A3 = 0.6560E-03		

Multiple Correlation Coefficient = 0.999991; No. of Data Points = 204

T300/5208 - VF=61.8 - 0.0001 CM/MIN

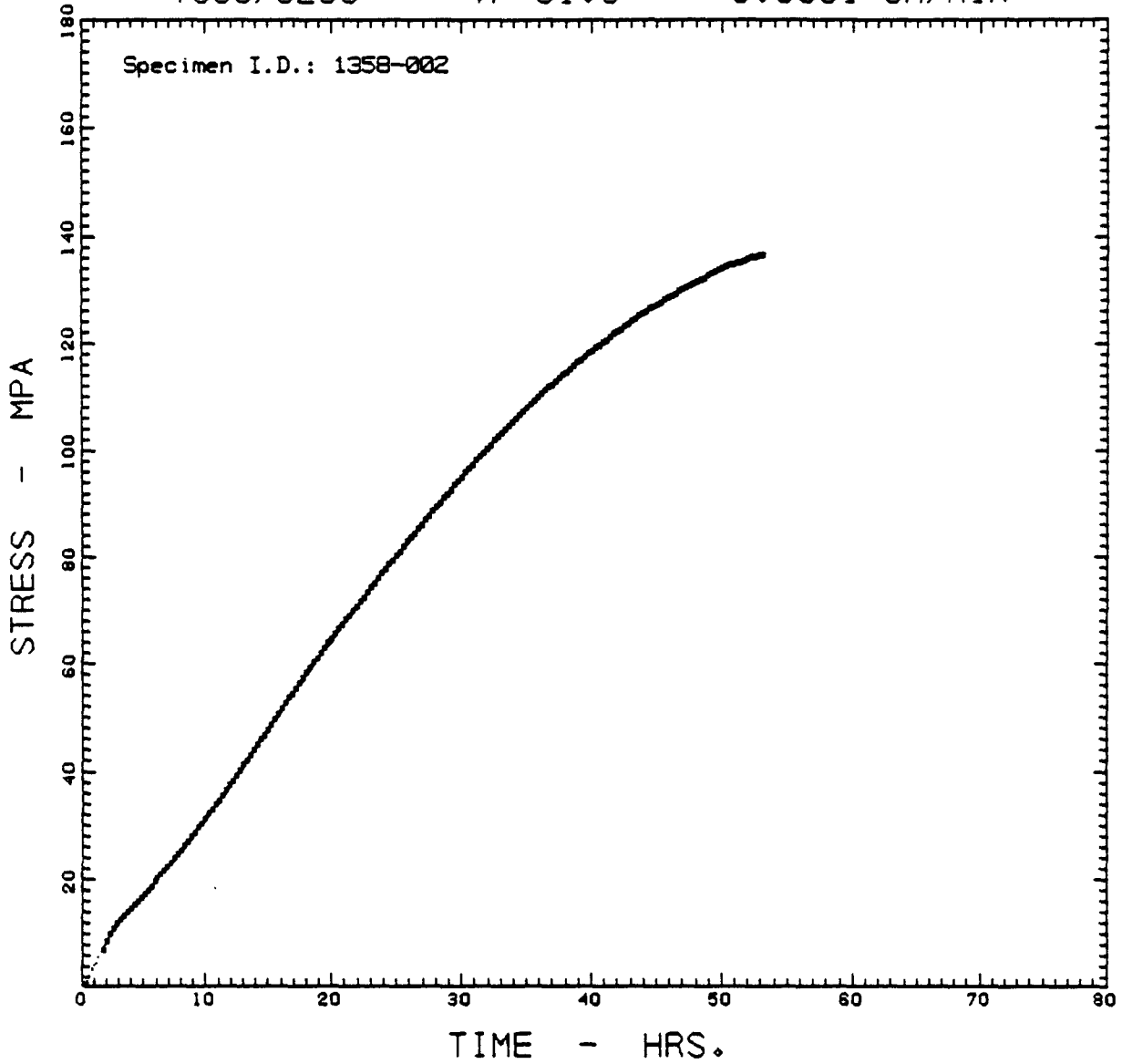

$$\text{STRESS} = A_0 + A_1 \cdot \text{TIME} + A_2 \cdot \text{TIME}^2 + \dots + A_9 \cdot \text{TIME}^9$$

where:

$$0.2886 \leq \text{TIME} \leq 53.0610$$

A0 = -0.1499E+01	A4 = -0.1124E-01	A7 = 0.1831E-06
A1 = 0.7021E+01	A5 = 0.4679E-03	A8 = -0.1550E-08
A2 = -0.1218E+01	A6 = -0.1194E-04	A9 = 0.5555E-11
A3 = 0.1601E+00		

Multiple Correlation Coefficient = 0.999995; No. of Data Points = 187

T300/5208 - VF=61.8 - 0.0001 CM/MIN

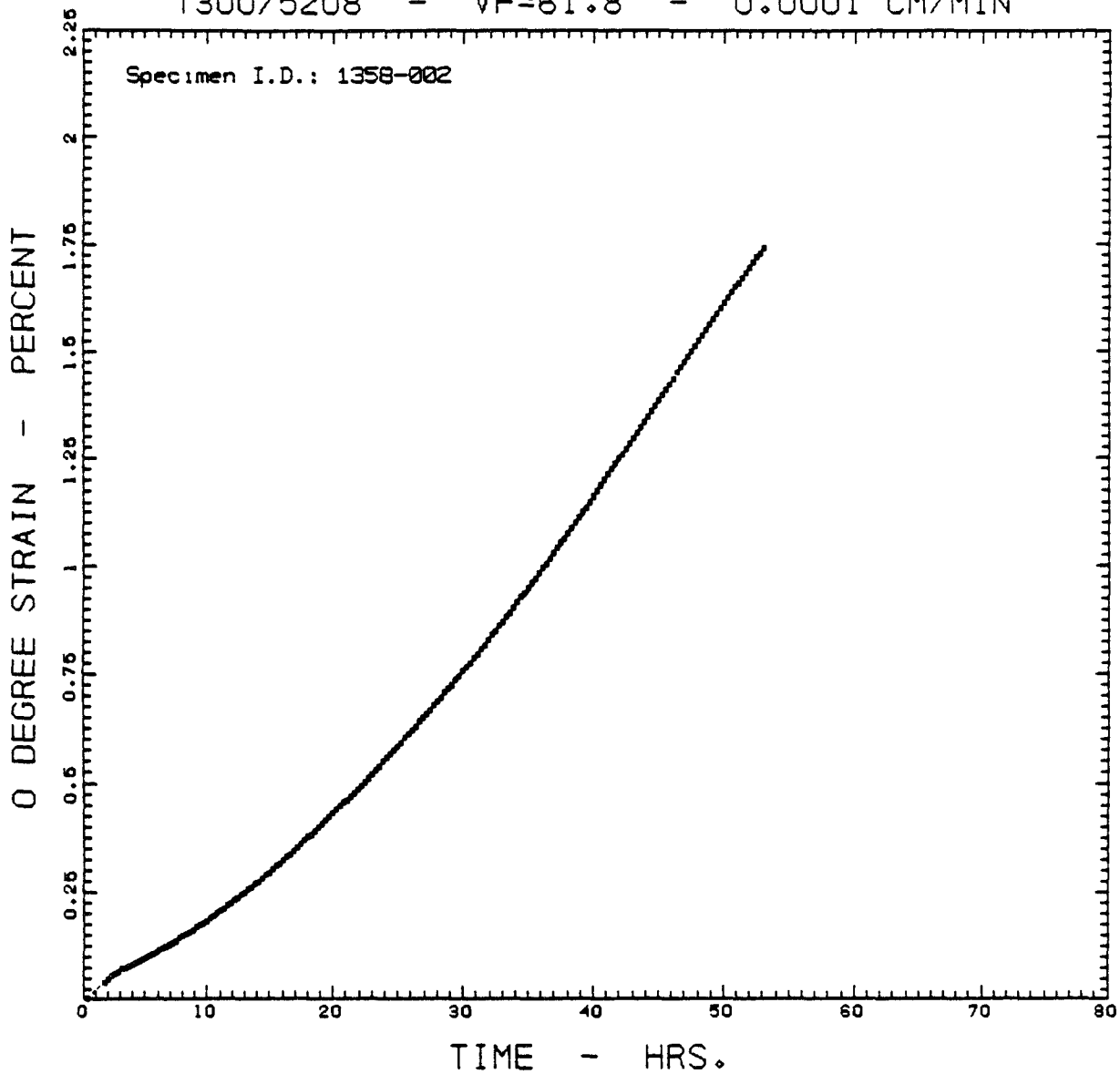

STRAIN = A0 + A1*TIME + A2*TIME^2 + ... + A9*TIME^9

where:

0.2886 < TIME < 53.0610

A0 = -0.7462E-02

A1 = 0.3788E-01

A2 = -0.6197E-02

A3 = 0.8008E-03

A4 = -0.5434E-04

A5 = 0.2223E-05

A6 = -0.5611E-07

A7 = 0.8544E-09

A8 = -0.7196E-11

A9 = 0.2571E-13

Multiple Correlation Coefficient = 0.999999; No. of Data Points = 187

T300/5208 - VF=61.8 - 0.0001 CM/MIN

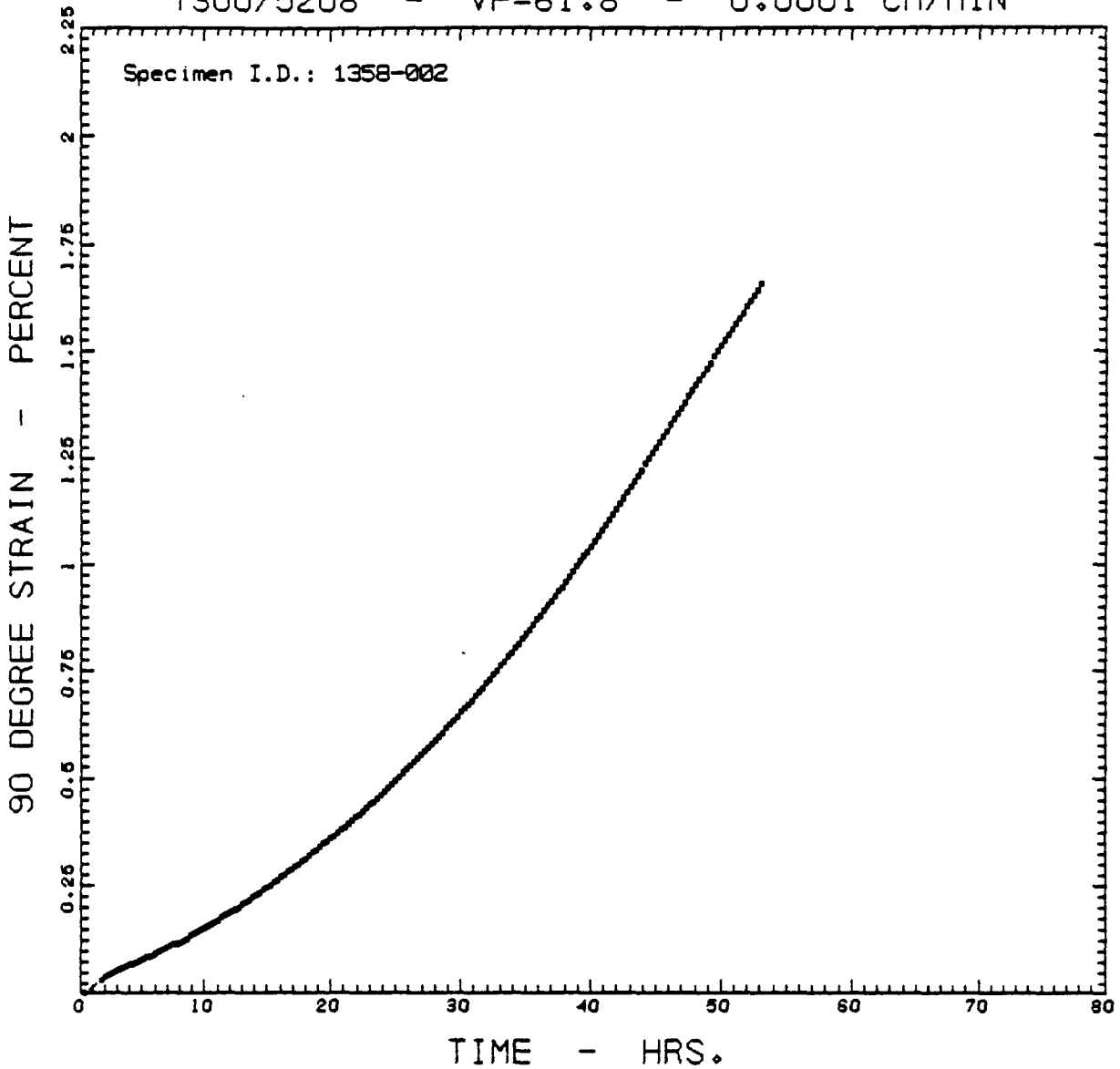

$$\text{STRAIN} = A_0 + A_1 \cdot \text{TIME} + A_2 \cdot \text{TIME}^2 + \dots + A_9 \cdot \text{TIME}^9$$

where:

$$0.2886 \leq \text{TIME} \leq 53.0610$$

A0 = -0.8248E-02	A4 = -0.4998E-04	A7 = 0.9079E-09
A1 = 0.3220E-01	A5 = 0.2132E-05	A8 = -0.8137E-11
A2 = -0.5414E-02	A6 = -0.5643E-07	A9 = 0.3115E-13
A3 = 0.7134E-03		

Multiple Correlation Coefficient = 0.999999; No. of Data Points = 187

T300/5208 - VF=60.1 - 0.0001 CM/MIN

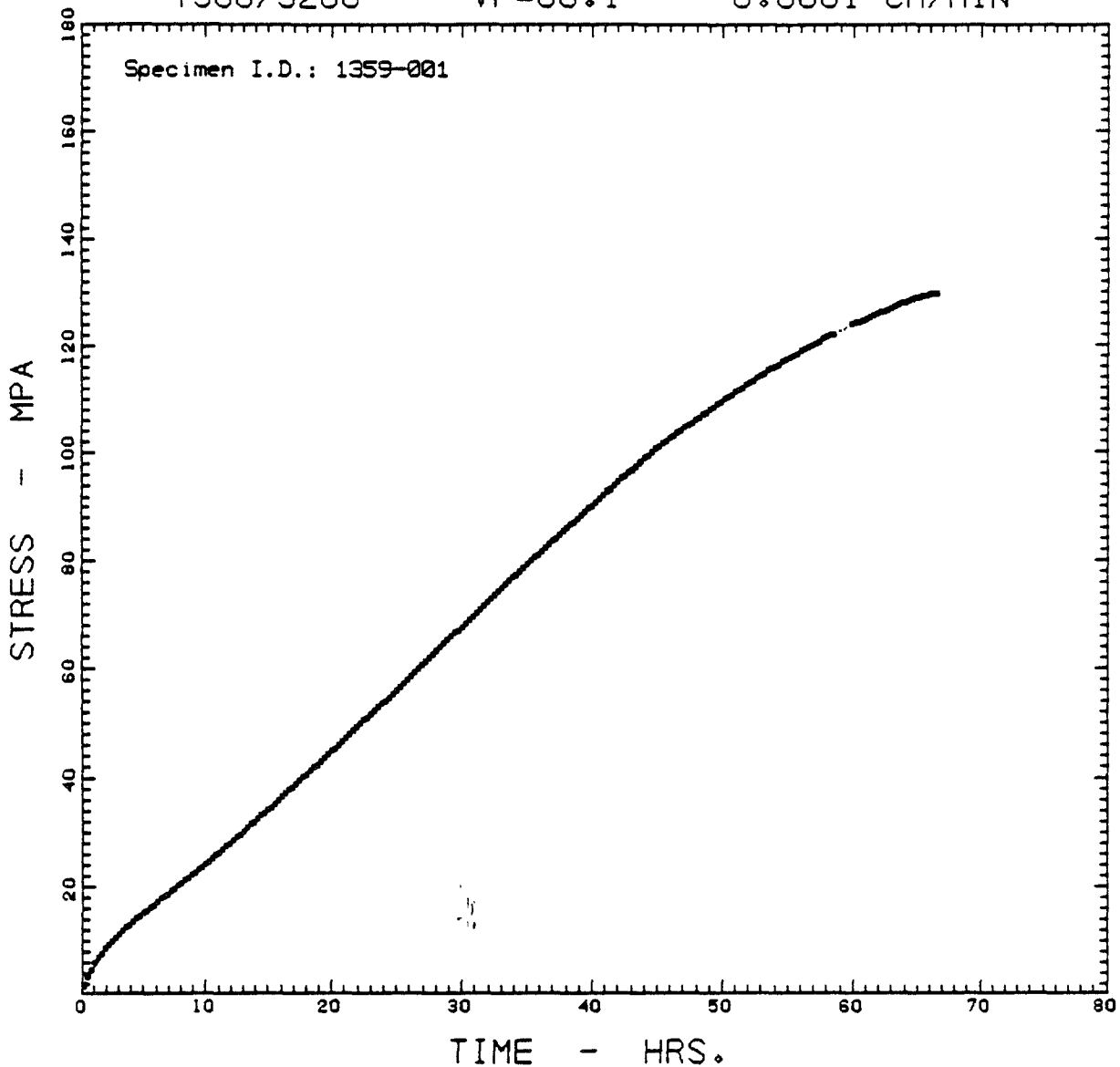

$$\text{STRESS} = A_0 + A_1 \cdot \text{TIME} + A_2 \cdot \text{TIME}^2 + \dots + A_9 \cdot \text{TIME}^9$$

where:

0.2194 < TIME < 66.6016

A0 = 0.1090E+01	A4 = -0.3845E-02	A7 = 0.4264E-07
A1 = 0.4726E+01	A5 = 0.1395E-03	A8 = -0.3190E-09
A2 = -0.6158E+00	A6 = -0.3142E-05	A9 = 0.1008E-11
A3 = 0.6484E-01		

Multiple Correlation Coefficient = 0.999990; No. of Data Points = 236

T300/5208 - VF=60.1 - 0.0001 CM/MIN

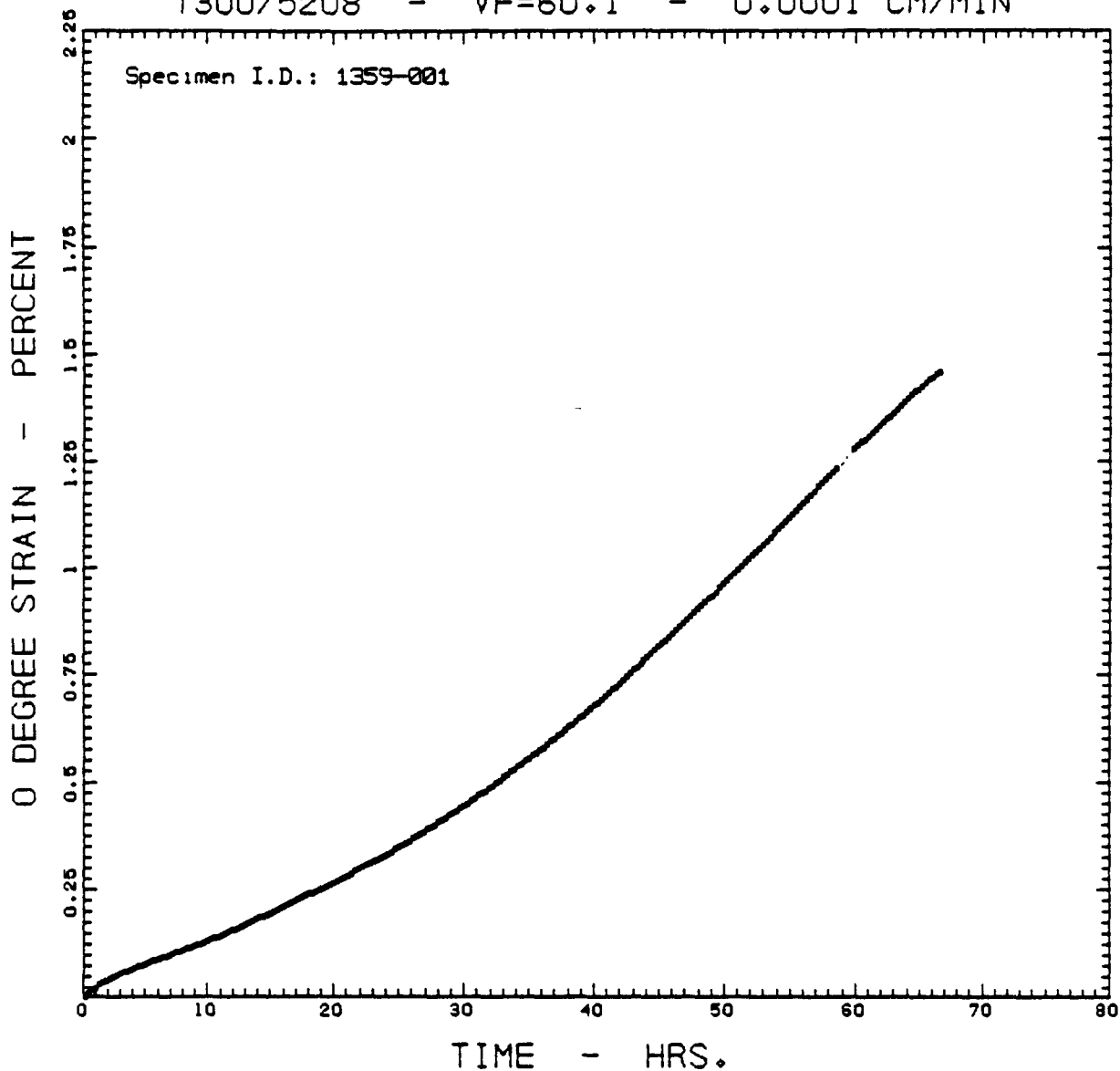

STRAIN = A0 + A1*TIME + A2*TIME^2 + ... + A9*TIME^9

where:

0.2194 < TIME < 66.6016

A0 = -0.3158E-03

A1 = 0.2614E-01

A2 = -0.3490E-02

A3 = 0.3868E-03

A4 = -0.2364E-04

A5 = 0.8776E-06

A6 = -0.1996E-07

A7 = 0.2717E-09

A8 = -0.2028E-11

A9 = 0.6381E-14

Multiple Correlation Coefficient = 0.999997; No. of Data Points = 236

T300/5208 - VF=60.1 - 0.0001 CM/MIN

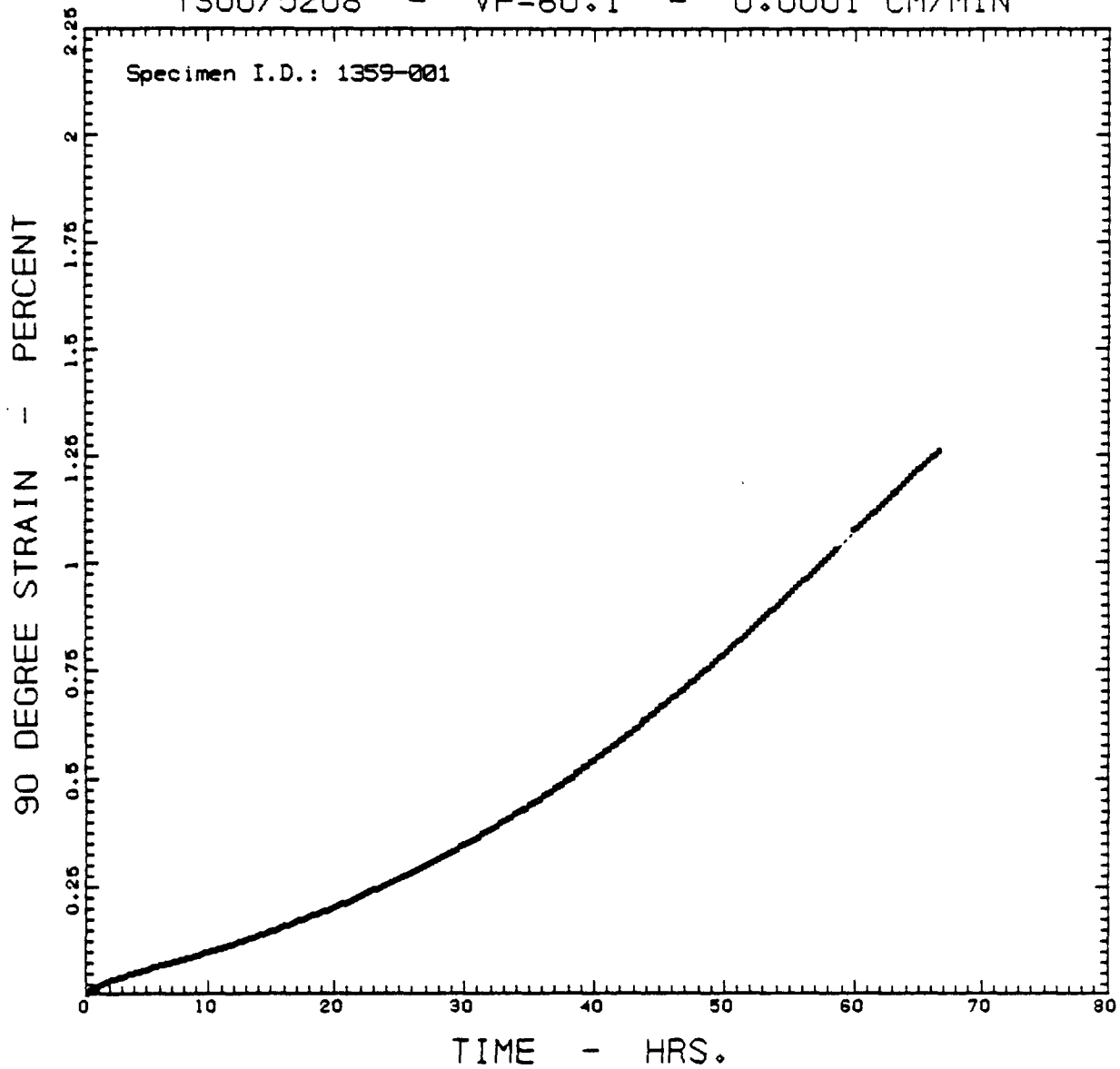

$$\text{STRAIN} = A_0 + A_1 \cdot \text{TIME} + A_2 \cdot \text{TIME}^2 + \dots + A_9 \cdot \text{TIME}^9$$

where:

$$0.2194 \leq \text{TIME} \leq 66.6016$$

A0 = 0.1141E-02	A4 = -0.1764E-04	A7 = 0.2170E-09
A1 = 0.1884E-01	A5 = 0.6698E-06	A8 = -0.1652E-11
A2 = -0.2505E-02	A6 = -0.1560E-07	A9 = 0.5290E-14
A3 = 0.2834E-03		

Multiple Correlation Coefficient = 0.999997; No. of Data Points = 236

T300/5208 - VF=60.1 - 0.0001 CM/MIN

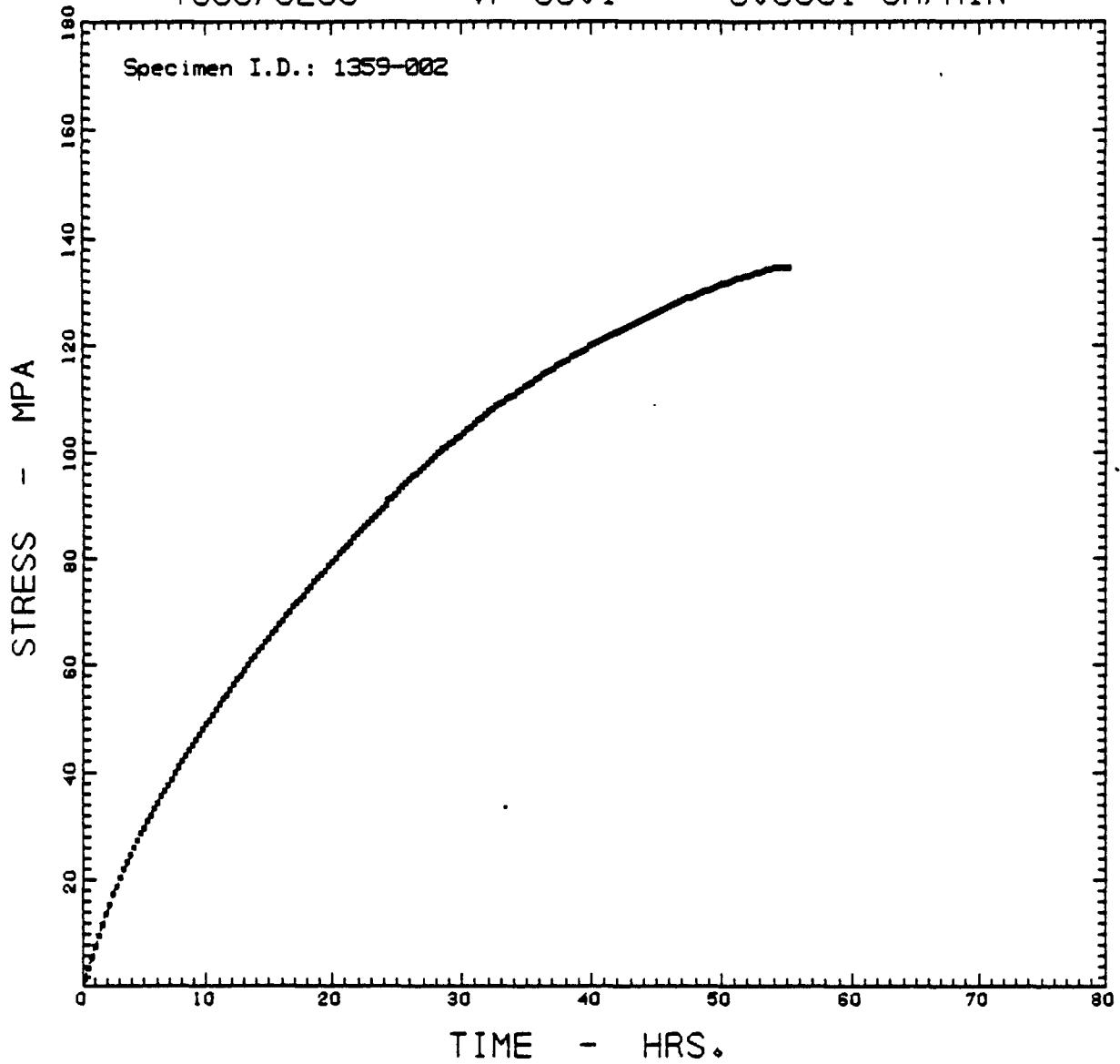

$$\text{STRESS} = A_0 + A_1 \cdot \text{TIME} + A_2 \cdot \text{TIME}^2 + \dots + A_9 \cdot \text{TIME}^9$$

where:

$$0.1832 \leq \text{TIME} \leq 55.1776$$

$$A_0 = -0.2768E+00$$

$$A_1 = 0.8737E+01$$

$$A_2 = -0.7959E+00$$

$$A_3 = 0.6922E-01$$

$$A_4 = -0.3836E-02$$

$$A_5 = 0.1346E-03$$

$$A_6 = -0.3001E-05$$

$$A_7 = 0.4109E-07$$

$$A_8 = -0.3136E-09$$

$$A_9 = 0.1015E-11$$

Multiple Correlation Coefficient = 0.999996; No. of Data Points = 199

T300/5208 - VF=60.1 - 0.0001 CM/MIN

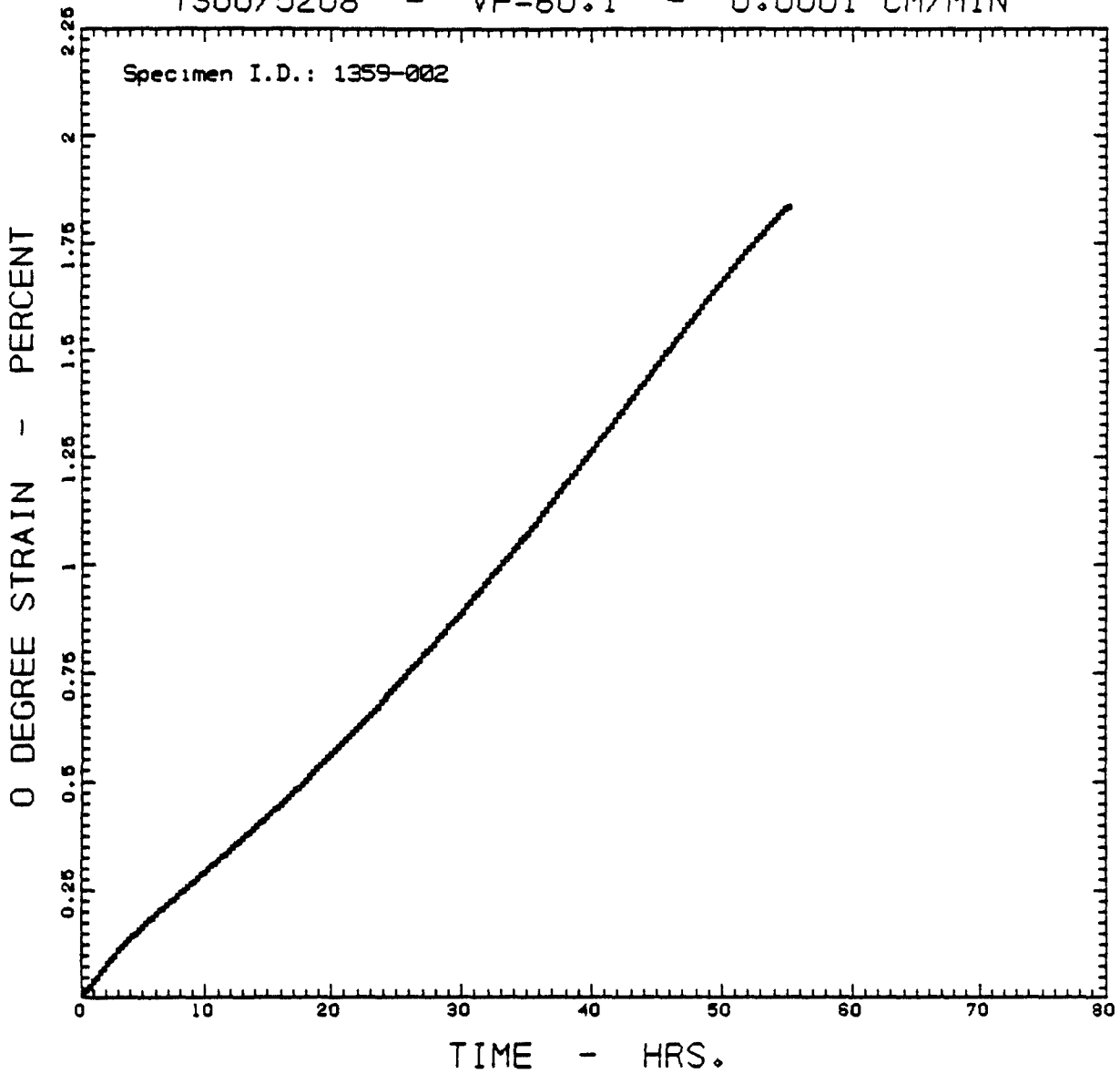

$$\text{STRAIN} = A_0 + A_1 \cdot \text{TIME} + A_2 \cdot \text{TIME}^2 + \dots + A_9 \cdot \text{TIME}^9$$

where:

$$0.1832 \leq \text{TIME} \leq 55.1776$$

$$A_0 = -0.2831E-02$$

$$A_1 = 0.4497E-01$$

$$A_2 = -0.3215E-02$$

$$A_3 = 0.2632E-03$$

$$A_4 = -0.1288E-04$$

$$A_5 = 0.4350E-06$$

$$A_6 = -0.1014E-07$$

$$A_7 = 0.1534E-09$$

$$A_8 = -0.1330E-11$$

$$A_9 = 0.4913E-14$$

Multiple Correlation Coefficient = 0.999999; No. of Data Points = 199

T300/5208 - VF=60.1 - 0.0001 CM/MIN

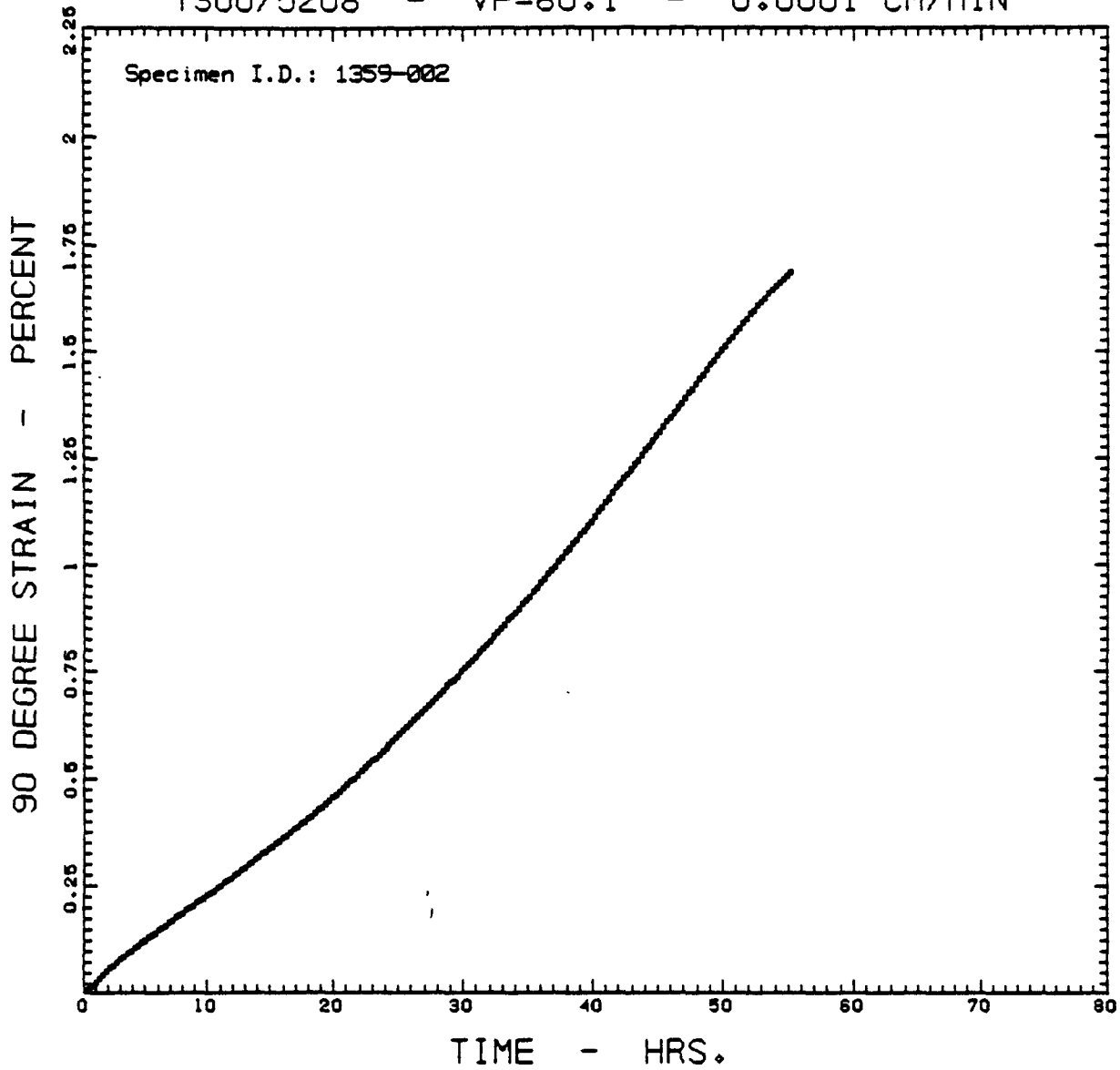

$$\text{STRAIN} = A_0 + A_1 \cdot \text{TIME} + A_2 \cdot \text{TIME}^2 + \dots + A_9 \cdot \text{TIME}^9$$

where:

$$0.1832 \leq \text{TIME} \leq 55.1776$$

A0 = -0.2908E-02	A4 = -0.4443E-05	A7 = -0.4381E-10
A1 = 0.3260E-01	A5 = 0.5454E-07	A8 = 0.5951E-12
A2 = -0.1933E-02	A6 = 0.9611E-09	A9 = -0.2973E-14
A3 = 0.1376E-03		

Multiple Correlation Coefficient = 0.999999; No. of Data Points = 199

T300/5208 - VF=60.1 - 0.0001 CM/MIN

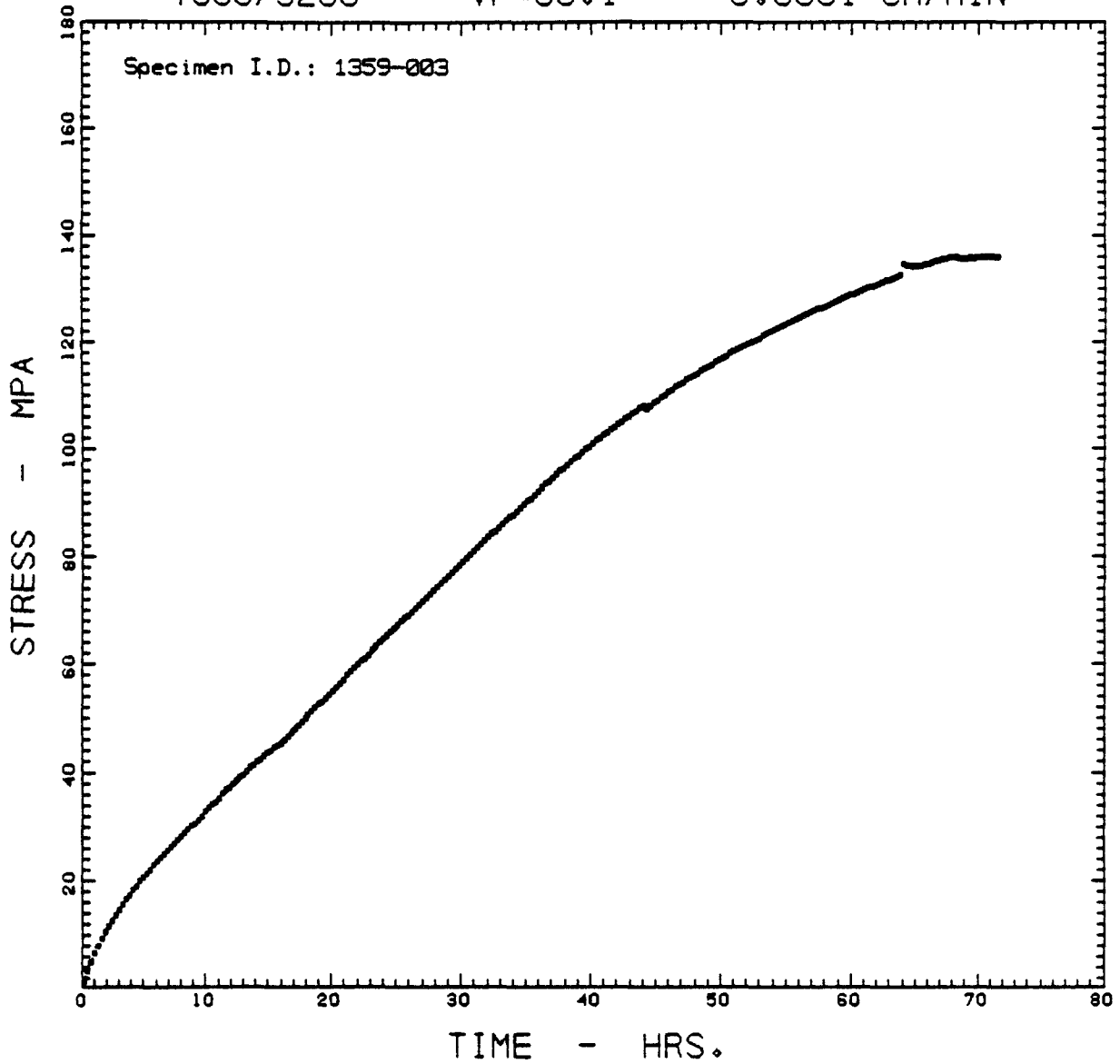

$$\text{STRESS} = A_0 + A_1 \cdot \text{TIME} + A_2 \cdot \text{TIME}^2 + \dots + A_9 \cdot \text{TIME}^9$$

where:

$$0.1721 \leq \text{TIME} \leq 71.5538$$

A0 = 0.1028E+01	A4 = -0.1300E-02	A7 = 0.7635E-08
A1 = 0.5633E+01	A5 = 0.3538E-04	A8 = -0.5073E-10
A2 = -0.4582E+00	A6 = -0.6501E-06	A9 = 0.1429E-12
A3 = 0.3154E-01		

Multiple Correlation Coefficient = 0.999962; No. of Data Points = 258

T300/5208 - VF=60.1 - 0.0001 CM/MIN

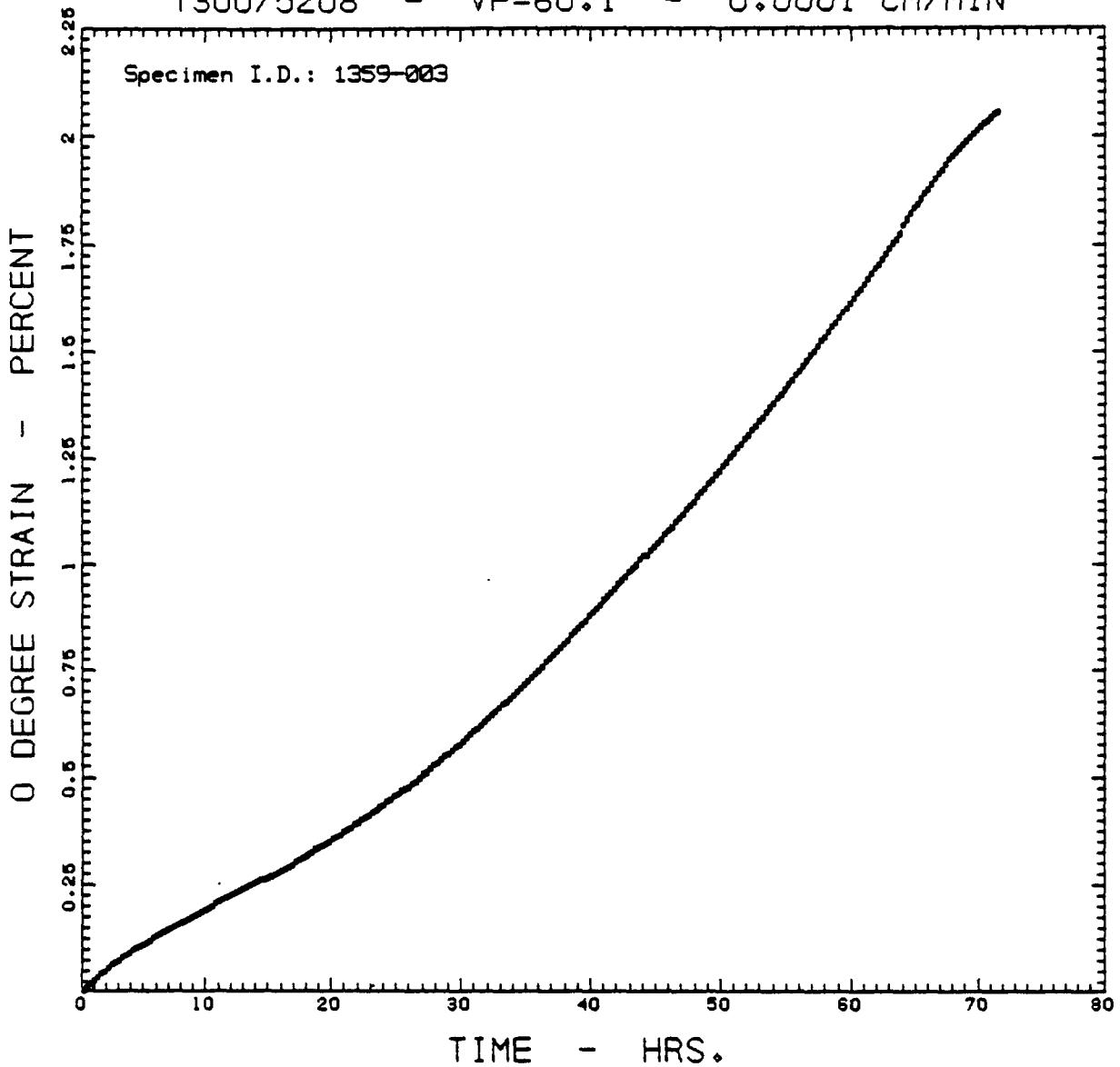

STRAIN = A0 + A1*TIME + A2*TIME^2 + ... + A9*TIME^9

where:

0.1721 < TIME < 71.5538

A0 = -0.2606E-02	A4 = -0.7153E-05	A7 = 0.5134E-10
A1 = 0.3131E-01	A5 = 0.2235E-06	A8 = -0.2976E-12
A2 = -0.2244E-02	A6 = -0.4456E-08	A9 = 0.6148E-15
A3 = 0.1605E-03		

Multiple Correlation Coefficient = 0.999990; No. of Data Points = 258

T300/5208 - VF=60.1 - 0.0001 CM/MIN

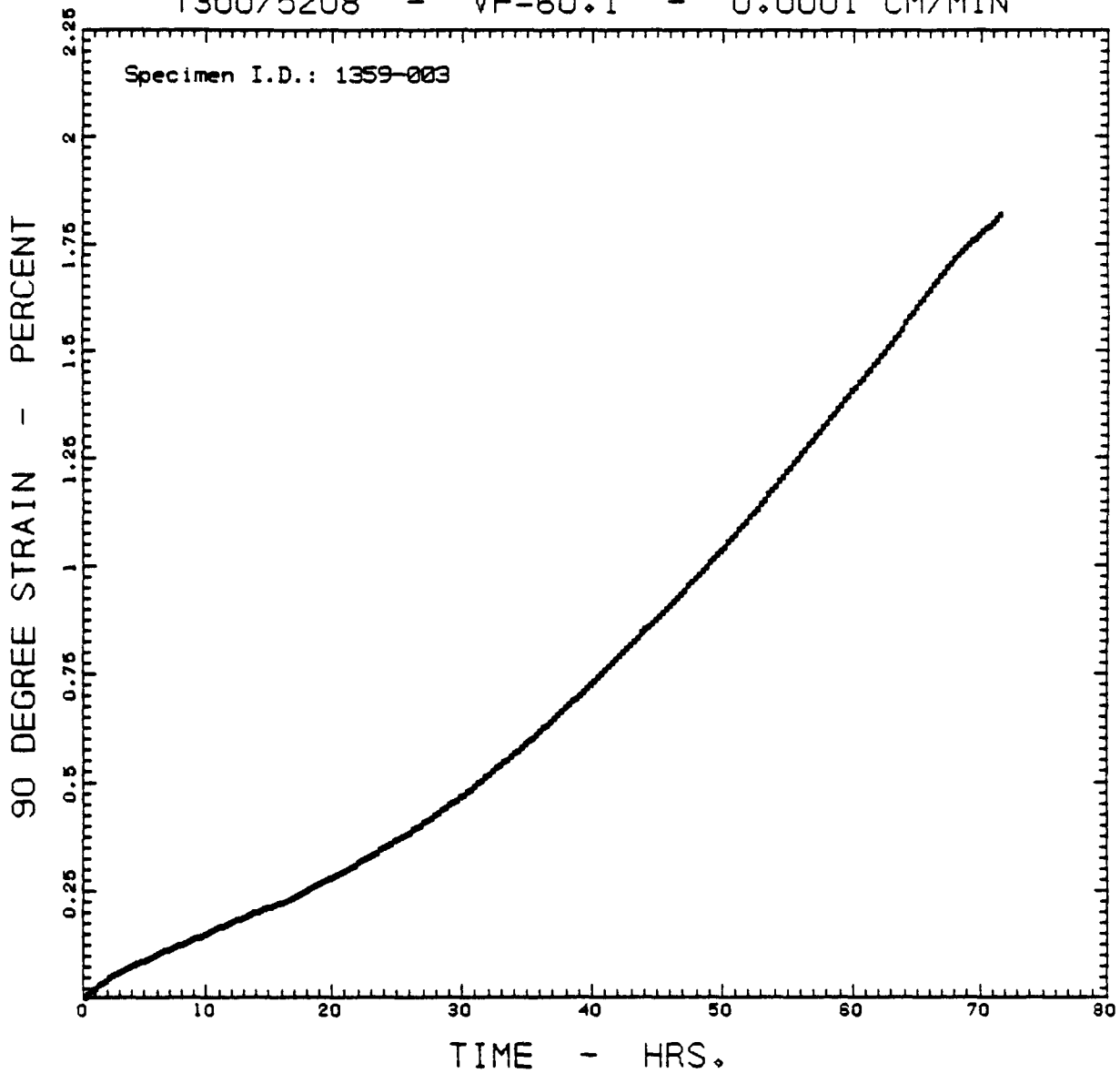

STRAIN = A0 + A1*TIME + A2*TIME^2 + ... + A9*TIME^9

where:

0.1721 < TIME < 71.5538

A0 = 0.1771E-02	A4 = -0.4142E-05	A7 = 0.2367E-10
A1 = 0.2319E-01	A5 = 0.1185E-06	A8 = -0.1213E-12
A2 = -0.1560E-02	A6 = -0.2208E-08	A9 = 0.1775E-15
A3 = 0.1044E-03		

Multiple Correlation Coefficient = 0.999992; No. of Data Points = 258

T300/5208 - VF=60.1 - 0.0001 CM/MIN

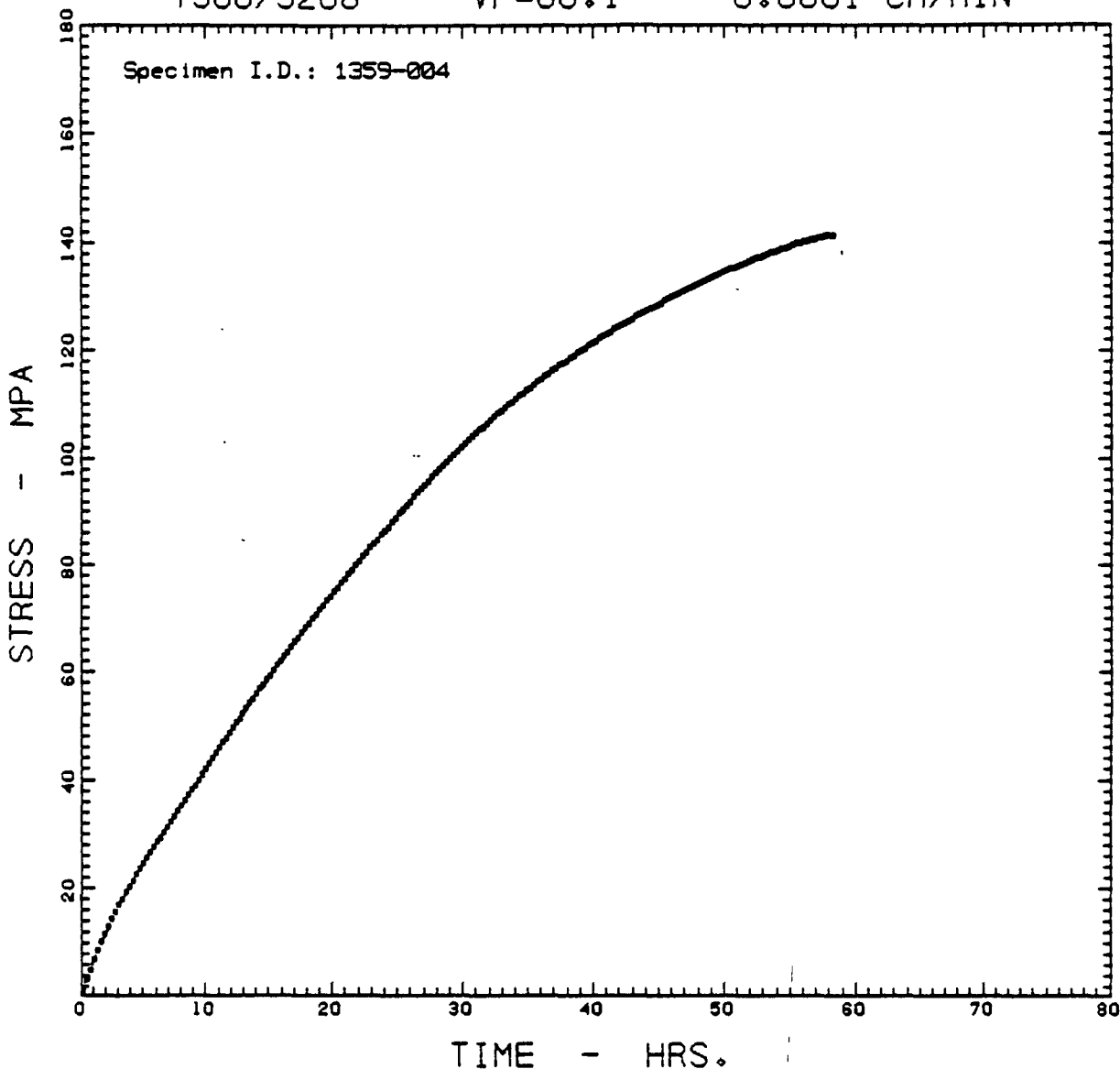

$$\text{STRESS} = A_0 + A_1 \cdot \text{TIME} + A_2 \cdot \text{TIME}^2 + \dots + A_9 \cdot \text{TIME}^9$$

where:

$$0.1624 \leq \text{TIME} \leq 58.2122$$

A0 = 0.3550E+00	A4 = -0.5061E-02	A7 = 0.8258E-07
A1 = 0.7086E+01	A5 = 0.2067E-03	A8 = -0.7101E-09
A2 = -0.7155E+00	A6 = -0.5303E-05	A9 = 0.2579E-11
A3 = 0.7722E-01		

Multiple Correlation Coefficient = 0.999994; No. of Data Points = 210

T300/5208 - VF=60.1 - 0.0001 CM/MIN

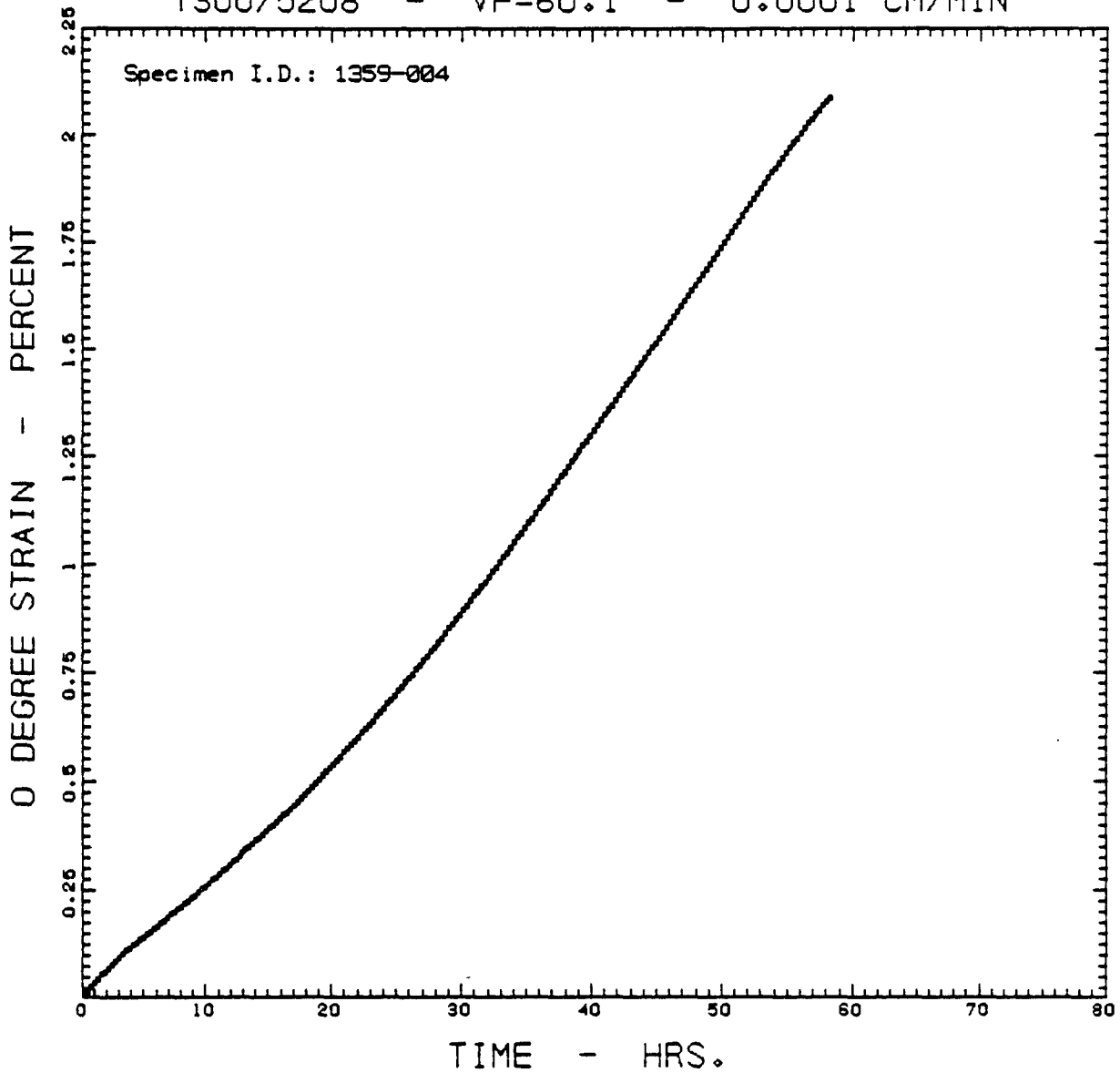

STRAIN = A0 + A1*TIME + A2*TIME^2 + ... + A9*TIME^9

where:

0.1624 < TIME < 58.2122

A0 = 0.7827E-03

A1 = 0.3823E-01

A2 = -0.3142E-02

A3 = 0.3379E-03

A4 = -0.2147E-04

A5 = 0.8969E-06

A6 = -0.2373E-07

A7 = 0.3771E-09

A8 = -0.3265E-11

A9 = 0.1178E-13

Multiple Correlation Coefficient = 0.999998; No. of Data Points = 210

T300/5208 - VF=60.1 - 0.0001 CM/MIN

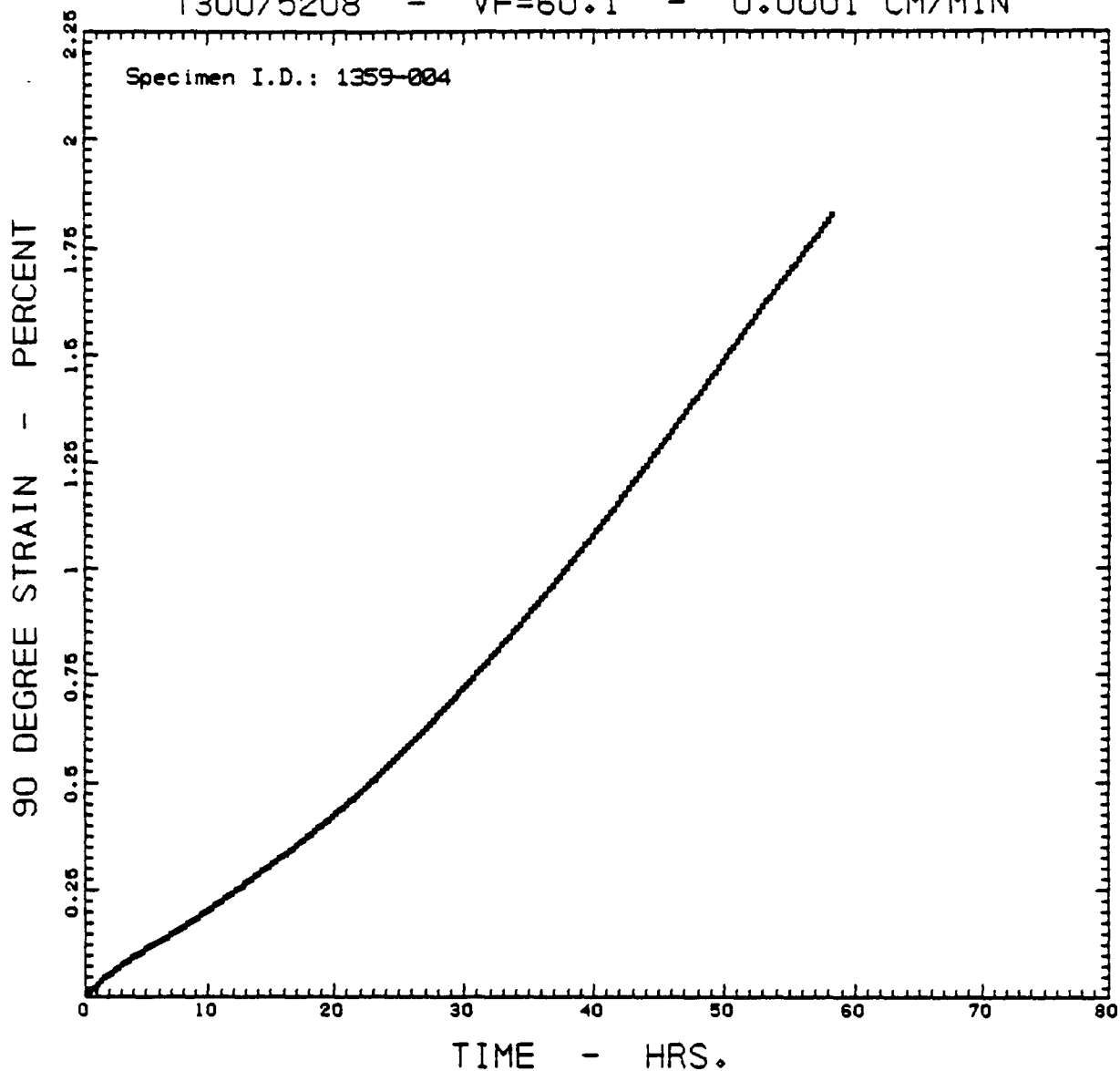

STRAIN = A0 + A1*TIME + A2*TIME^2 + ... + A9*TIME^9

where:

0.1624 <= TIME <= 58.2122

A0 = 0.2704E-02

A1 = 0.3158E-01

A2 = -0.3176E-02

A3 = 0.3739E-03

A4 = -0.2529E-04

A5 = 0.1084E-05

A6 = -0.2888E-07

A7 = 0.4599E-09

A8 = -0.4001E-11

A9 = 0.1459E-13

Multiple Correlation Coefficient = 0.999999; No. of Data Points = 210

T300/5208 - VF=60.1 - 0.0001 CM/MIN

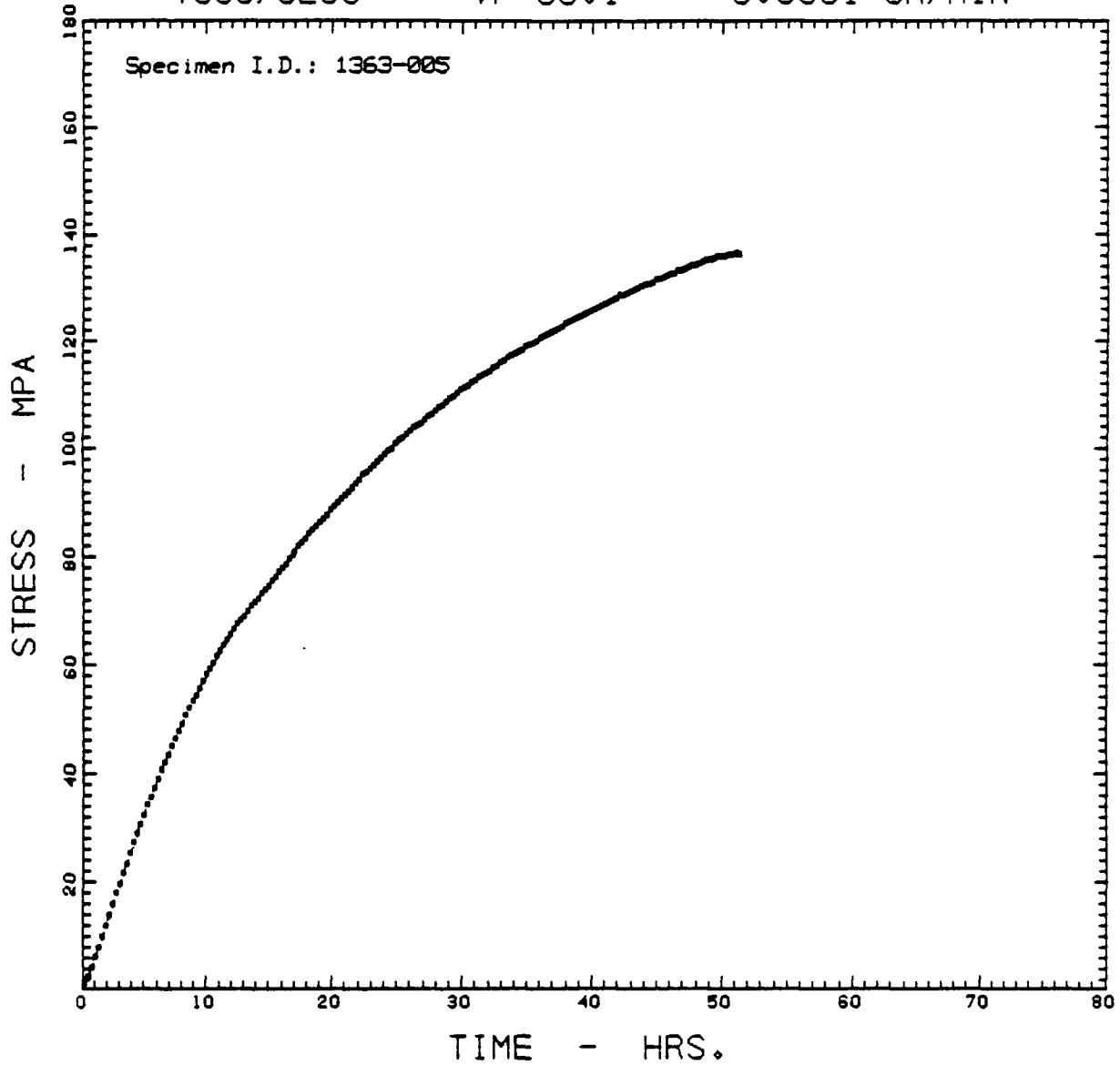

$$\text{STRESS} = A_0 + A_1 \cdot \text{TIME} + A_2 \cdot \text{TIME}^2 + \dots + A_9 \cdot \text{TIME}^9$$

where:

$$0.1701 \leq \text{TIME} \leq 51.2761$$

$$A_0 = -0.1042E+00$$

$$A_1 = 0.5768E+01$$

$$A_2 = 0.5655E+00$$

$$A_3 = -0.1147E+00$$

$$A_4 = 0.8885E-02$$

$$A_5 = -0.3828E-03$$

$$A_6 = 0.9884E-05$$

$$A_7 = -0.1525E-06$$

$$A_8 = 0.1301E-08$$

$$A_9 = -0.4744E-11$$

Multiple Correlation Coefficient = 0.999989; No. of Data Points = 185

T300/5208 - VF=60.1 - 0.0001 CM/MIN

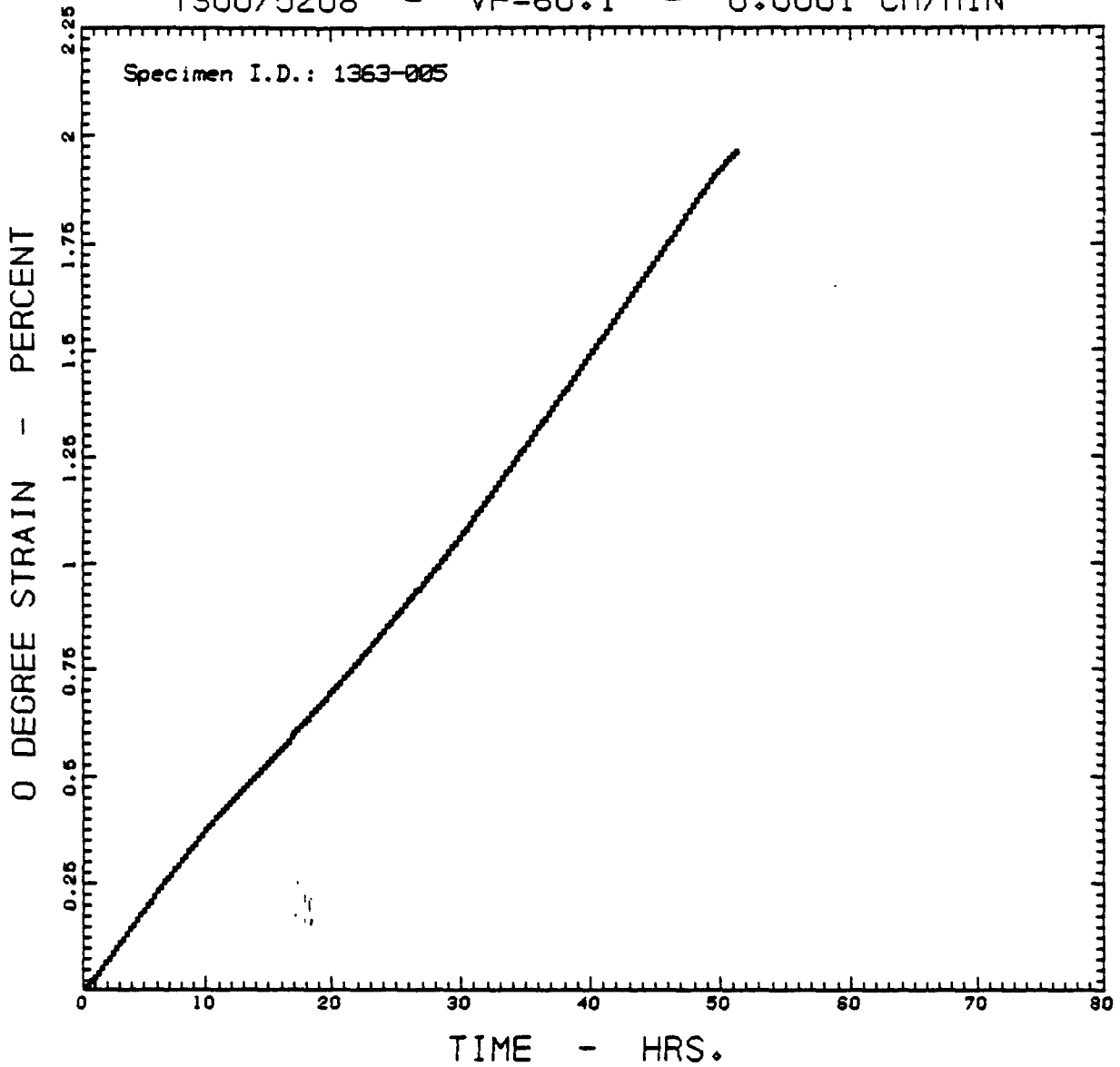

STRAIN = A0 + A1*TIME + A2*TIME^2 + ... + A9*TIME^9

where:

0.1701 < TIME < 51.2761

A0 = -0.7251E-03	A4 = 0.4421E-04	A7 = -0.7192E-09
A1 = 0.2949E-01	A5 = -0.1813E-05	A8 = 0.6458E-11
A2 = 0.3961E-02	A6 = 0.4591E-07	A9 = -0.2561E-13
A3 = -0.6149E-03		

Multiple Correlation Coefficient = 0.999996; No. of Data Points = 185

T300/5208 - VF=60.1 - 0.0001 CM/MIN

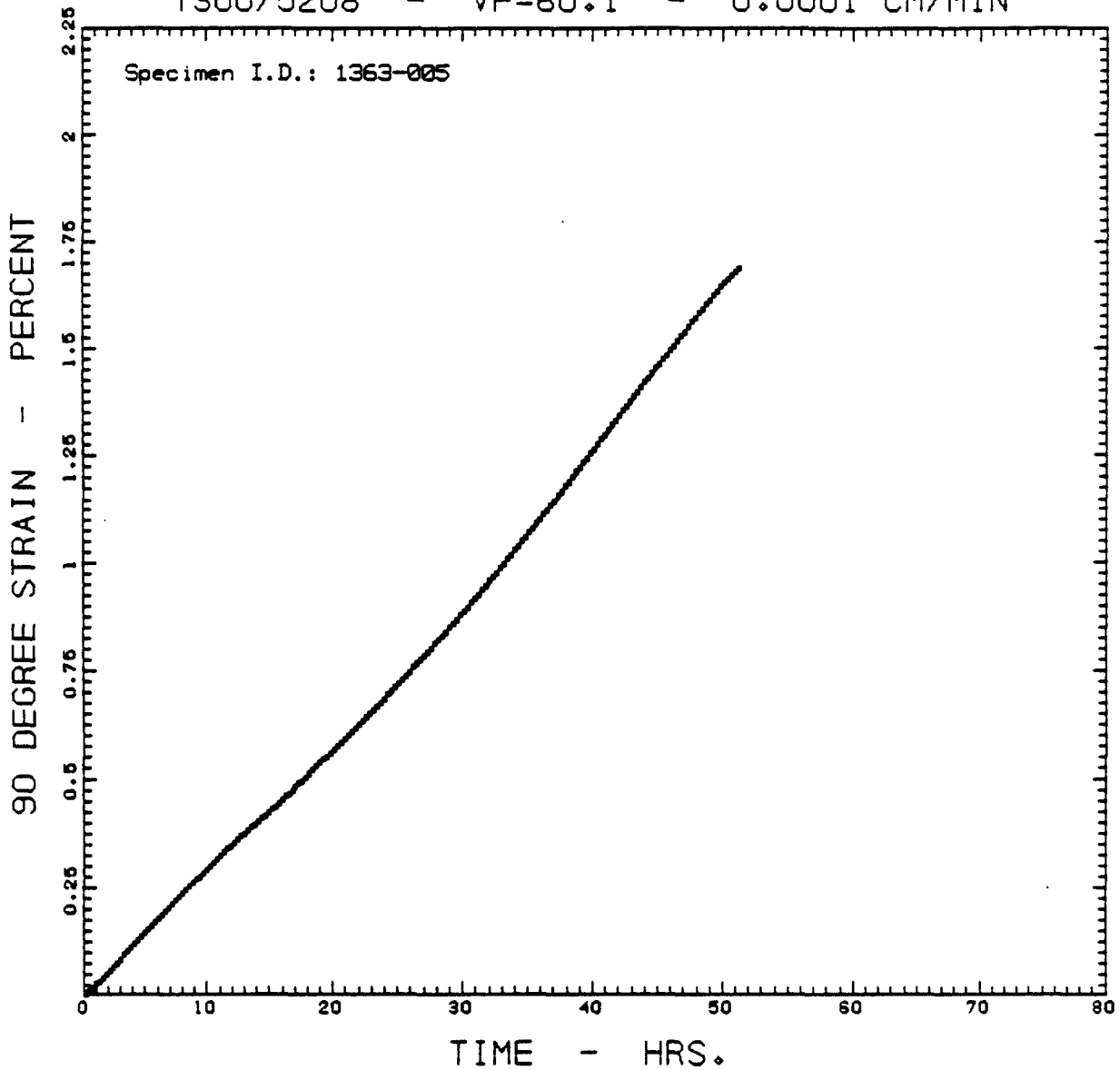

STRAIN = A0 + A1*TIME + A2*TIME^2 + ... + A9*TIME^9

where:

0.1701 = < TIME =< 51.2761

A0 = -0.1192E-02

A1 = 0.2425E-01

A2 = 0.2134E-02

A3 = -0.2820E-03

A4 = 0.1635E-04

A5 = -0.4849E-06

A6 = 0.7597E-08

A7 = -0.5601E-10

A8 = 0.1050E-12

A9 = 0.3214E-15

Multiple Correlation Coefficient = 0.999997; No. of Data Points = 185

T300/5208 - VF=60.1 - 0.0001 CM/MIN

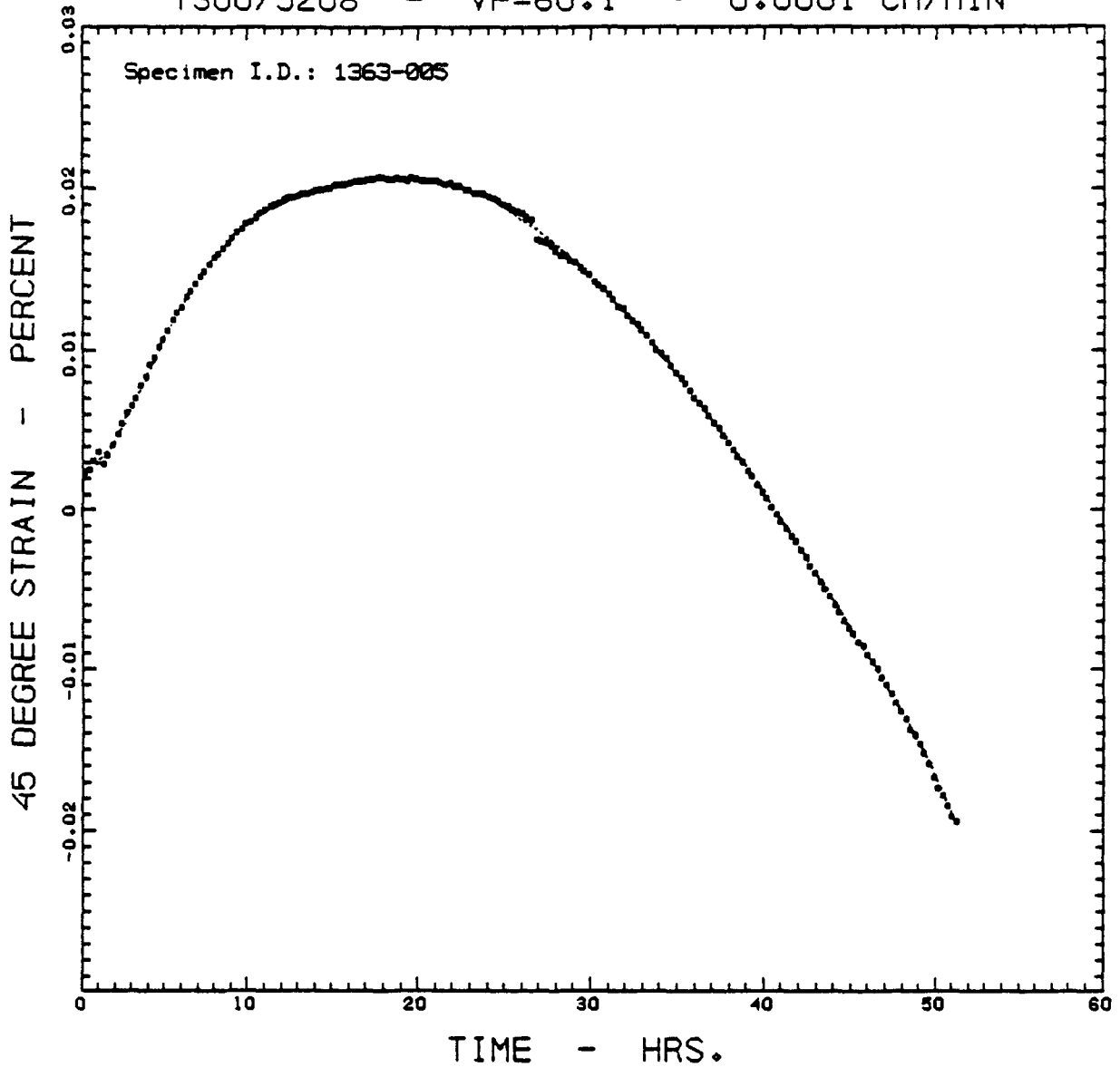

$$\text{STRAIN} = A_0 + A_1 \cdot \text{TIME} + A_2 \cdot \text{TIME}^2 + \dots + A_9 \cdot \text{TIME}^9$$

where:

$$0.1701 \leq \text{TIME} \leq 51.2761$$

$$A_0 = 0.2517E-02$$

$$A_1 = -0.2866E-03$$

$$A_2 = 0.9077E-03$$

$$A_3 = -0.1530E-03$$

$$A_4 = 0.1262E-04$$

$$A_5 = -0.6063E-06$$

$$A_6 = 0.1765E-07$$

$$A_7 = -0.3069E-09$$

$$A_8 = 0.2937E-11$$

$$A_9 = -0.1191E-13$$

Multiple Correlation Coefficient = 0.999826; No. of Data Points = 185

T300/5208 - VF=60.1 - 0.0001 CM/MIN

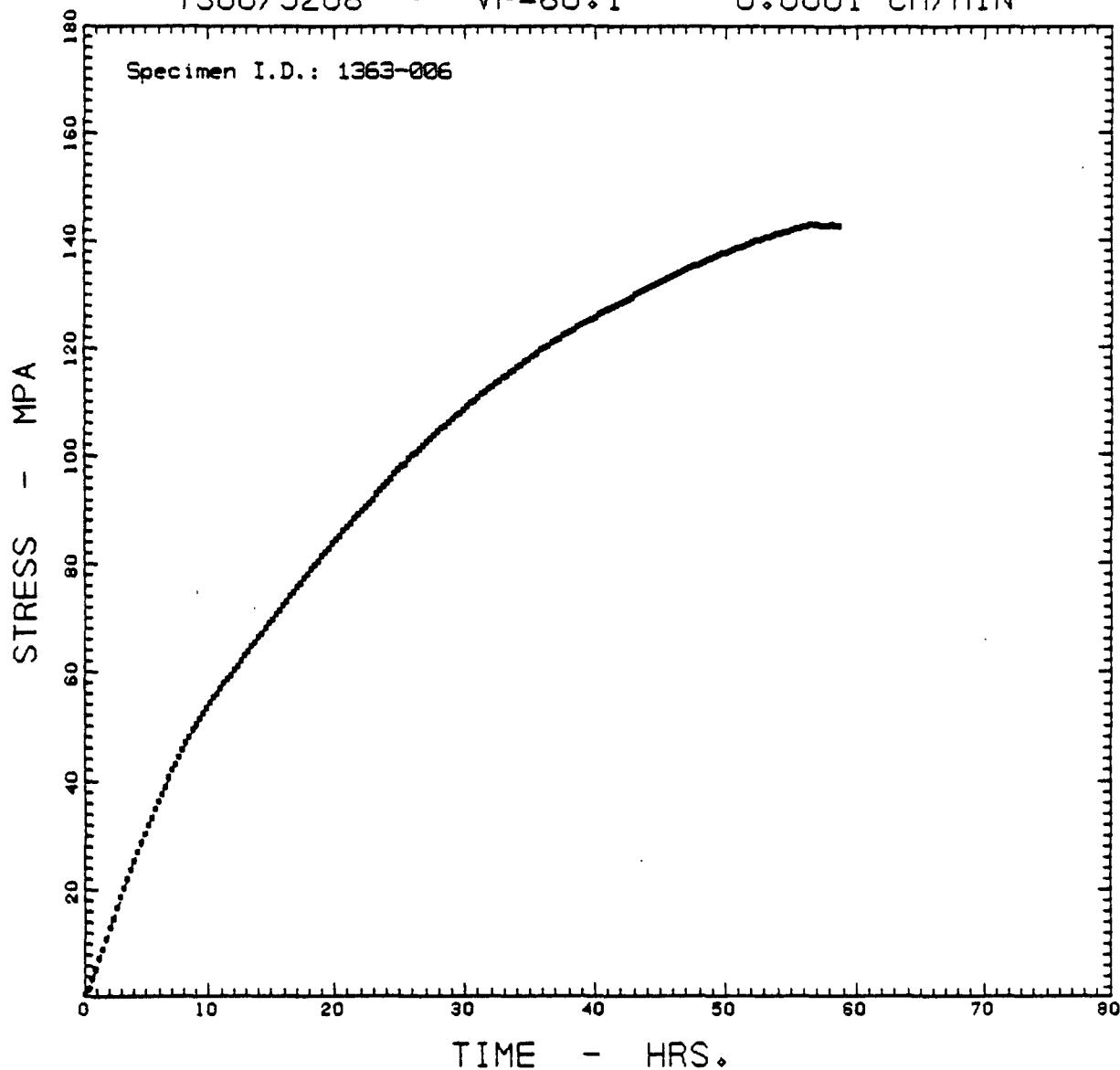

$$\text{STRESS} = A_0 + A_1 \cdot \text{TIME} + A_2 \cdot \text{TIME}^2 + \dots + A_9 \cdot \text{TIME}^9$$

where:

$$0.0653 \leq \text{TIME} \leq 58.6706$$

A0 = -0.4528E+00	A4 = 0.8849E-02	A7 = -0.1746E-06
A1 = 0.6247E+01	A5 = -0.4101E-03	A8 = 0.1499E-08
A2 = 0.3589E+00	A6 = 0.1106E-04	A9 = -0.5410E-11
A3 = -0.1009E+00		

Multiple Correlation Coefficient = 0.999989; No. of Data Points = 212

T300/5208 - VF=60.1 - 0.0001 CM/MIN

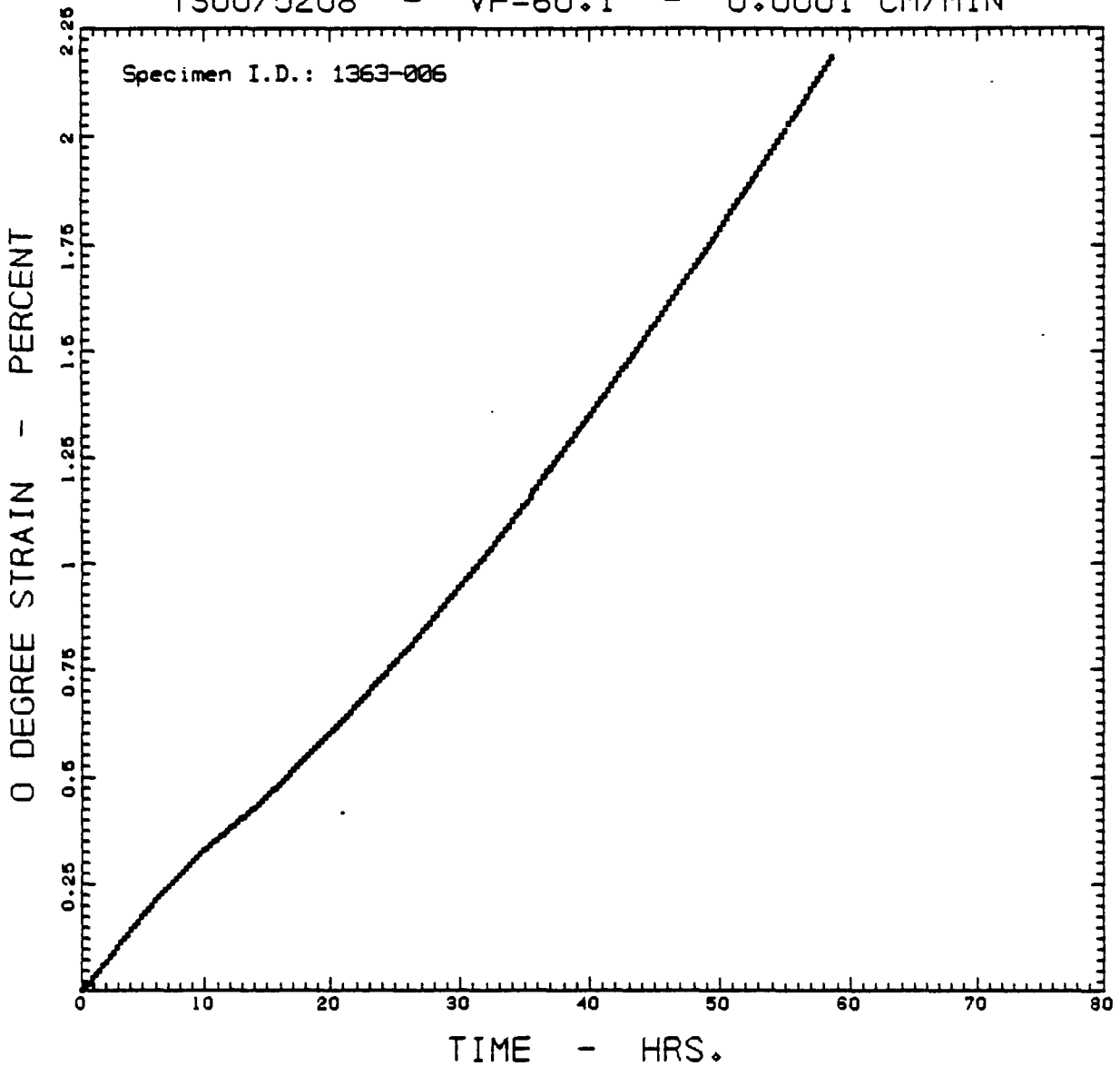

$$\text{STRAIN} = A_0 + A_1 \cdot \text{TIME} + A_2 \cdot \text{TIME}^2 + \dots + A_9 \cdot \text{TIME}^9$$

where:

$$0.0653 \leq \text{TIME} \leq 58.6706$$

$$A_0 = -0.5485E-03$$

$$A_1 = 0.3129E-01$$

$$A_2 = 0.3158E-02$$

$$A_3 = -0.6532E-03$$

$$A_4 = 0.5424E-04$$

$$A_5 = -0.2413E-05$$

$$A_6 = 0.6298E-07$$

$$A_7 = -0.9670E-09$$

$$A_8 = 0.8098E-11$$

$$A_9 = -0.2856E-13$$

Multiple Correlation Coefficient = 0.999998; No. of Data Points = 212

T300/5208 - VF=60.1 - 0.0001 CM/MIN

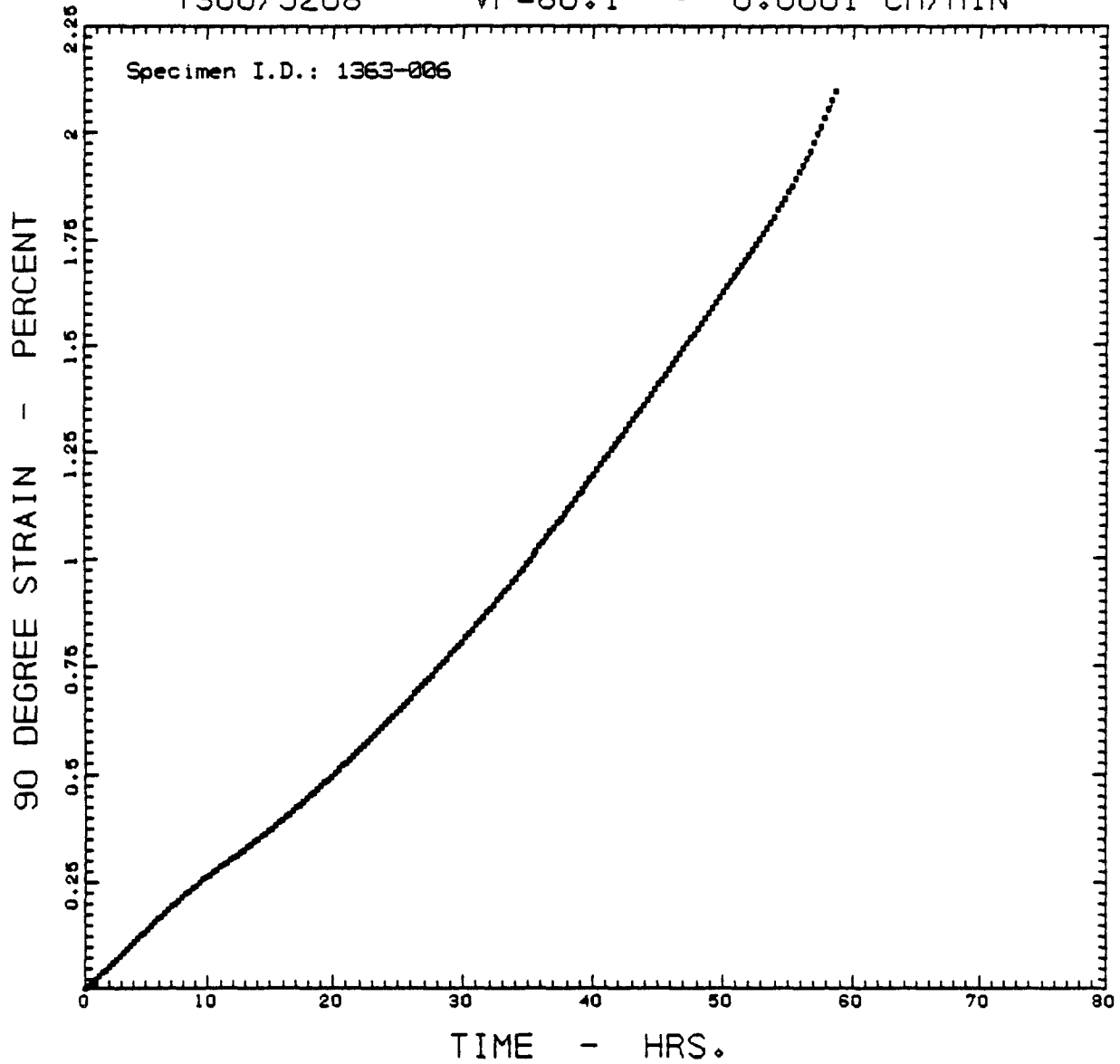

$$\text{STRAIN} = A_0 + A_1 \cdot \text{TIME} + A_2 \cdot \text{TIME}^2 + \dots + A_9 \cdot \text{TIME}^9$$

where:

$$0.0653 \leq \text{TIME} \leq 58.6706$$

$$A_0 = -0.9891E-03$$

$$A_1 = 0.2426E-01$$

$$A_2 = 0.2252E-02$$

$$A_3 = -0.4230E-03$$

$$A_4 = 0.3247E-04$$

$$A_5 = -0.1304E-05$$

$$A_6 = 0.2985E-07$$

$$A_7 = -0.3846E-09$$

$$A_8 = 0.2514E-11$$

$$A_9 = -0.6007E-14$$

Multiple Correlation Coefficient = 0.999998; No. of Data Points = 212

T300/5208 - VF=60.1 - 0.0001 CM/MIN

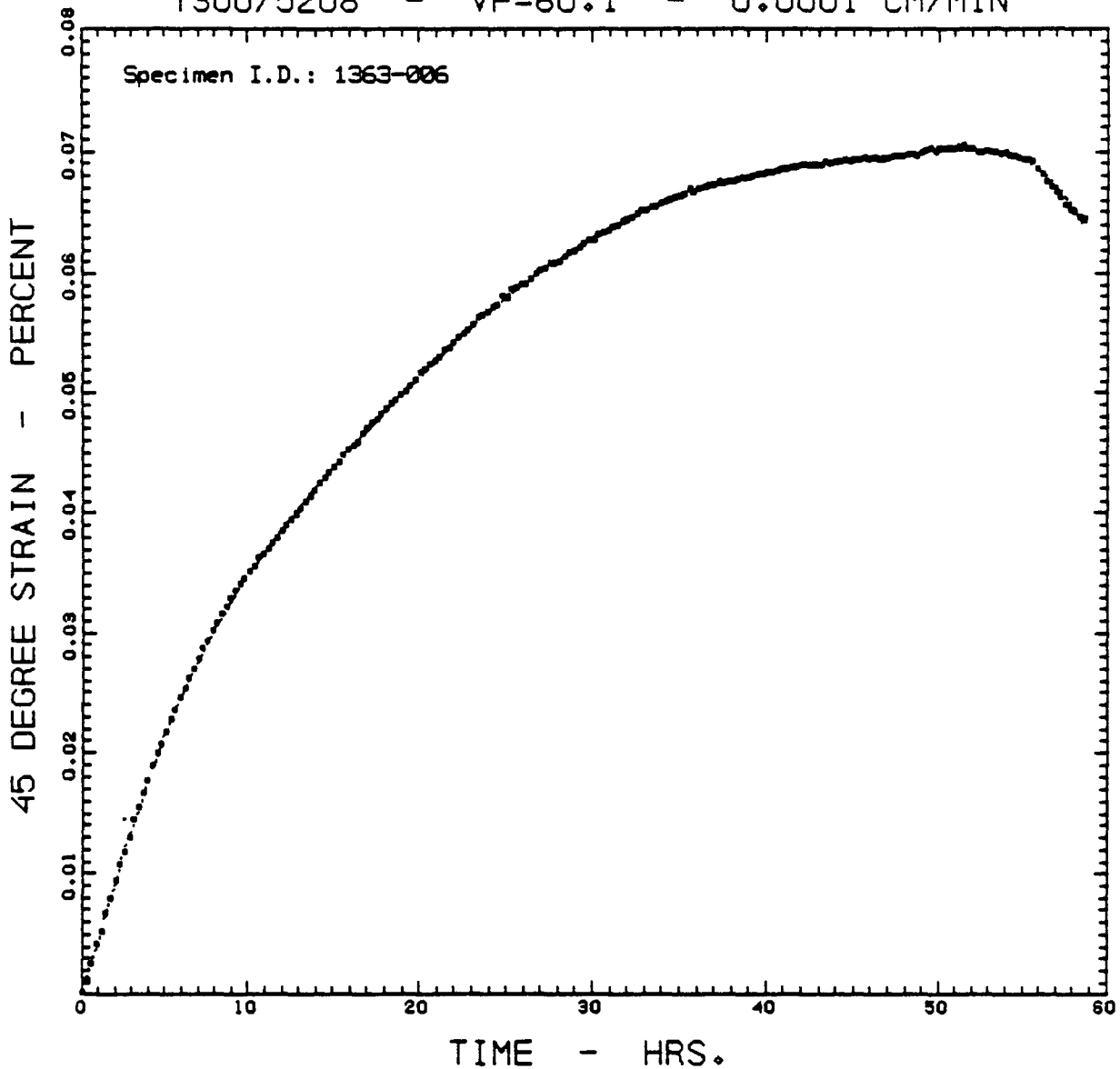

STRAIN = A0 + A1*TIME + A2*TIME^2 + ... + A9*TIME^9

where:

0.0653 < TIME < 58.6706

A0 = -0.5483E-03

A1 = 0.5276E-02

A2 = -0.9658E-04

A3 = -0.2537E-04

A4 = 0.2896E-05

A5 = -0.1442E-06

A6 = 0.3992E-08

A7 = -0.6386E-10

A8 = 0.5559E-12

A9 = -0.2049E-14

Multiple Correlation Coefficient = 0.999911; No. of Data Points = 212

T300/5208 - VF=61.8 - 0.01 CM/MIN

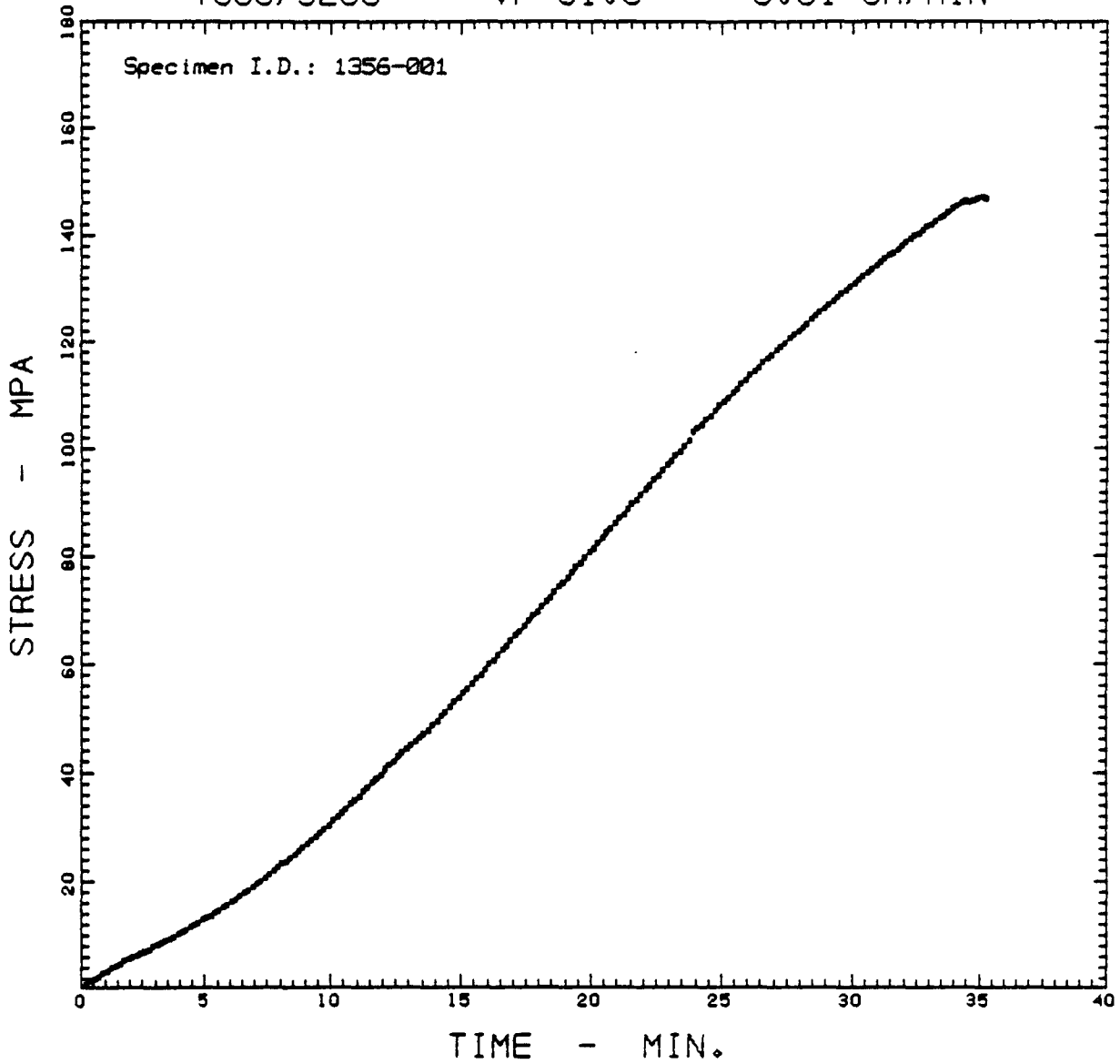

$$\text{STRESS} = A_0 + A_1 \cdot \text{TIME} + A_2 \cdot \text{TIME}^2 + \dots + A_9 \cdot \text{TIME}^9$$

where:

0.2294 < TIME < 35.2294

A0 = 0.5016E-01	A4 = -0.5958E-02	A7 = -0.6674E-06
A1 = 0.3536E+01	A5 = 0.5817E-04	A8 = 0.1425E-07
A2 = -0.5292E+00	A6 = 0.1207E-04	A9 = -0.1124E-09
A3 = 0.9551E-01		

Multiple Correlation Coefficient = 0.999989; No. of Data Points = 211

T300/5208 - VF=61.8 - 0.01 CM/MIN

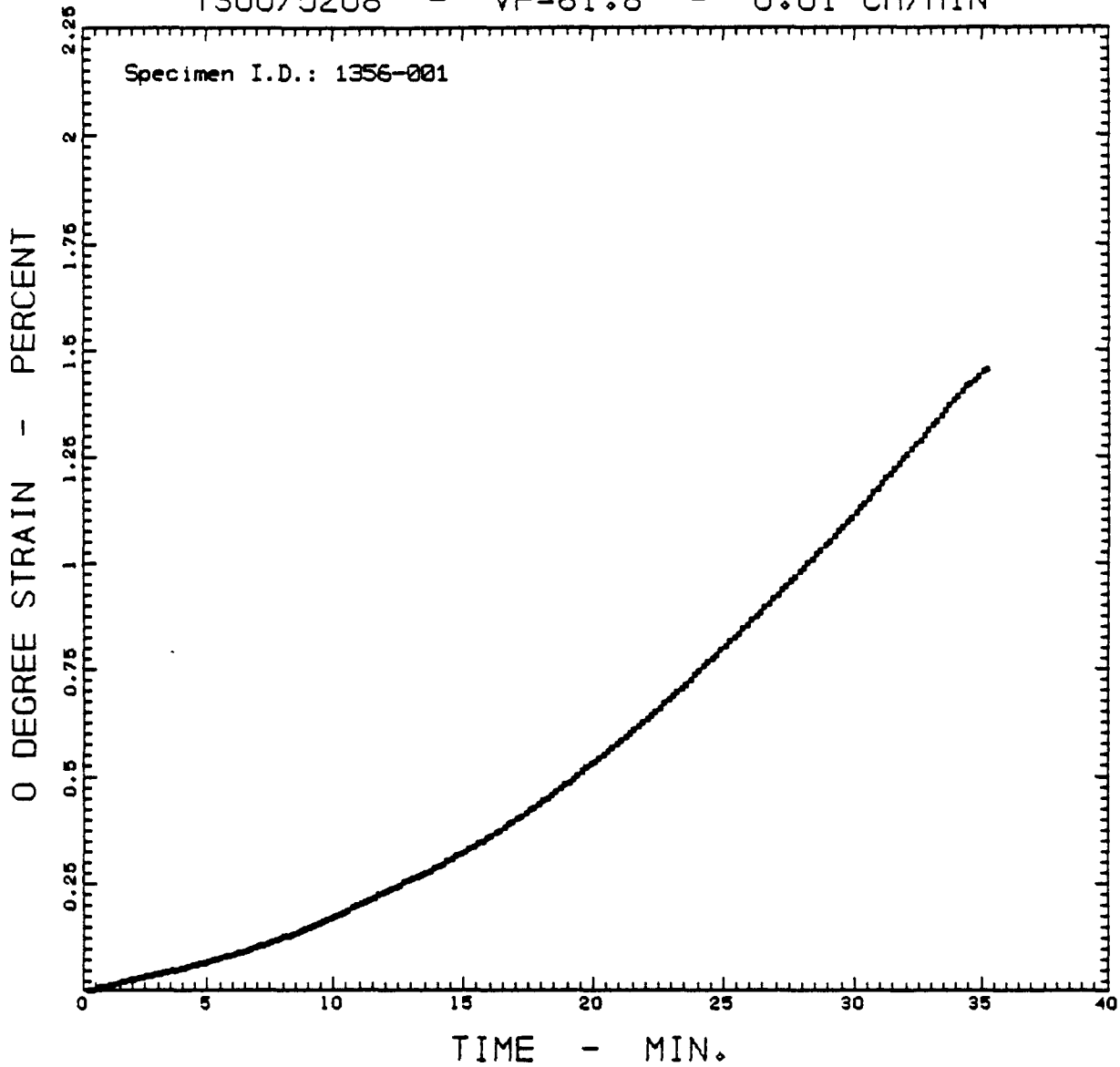

STRAIN = A0 + A1*TIME + A2*TIME^2 + ... + A9*TIME^9

where:

0.2294 < TIME < 35.2294

A0 = -0.1360E-02

A1 = 0.1497E-01

A2 = -0.4844E-03

A3 = -0.9206E-04

A4 = 0.5451E-04

A5 = -0.6826E-05

A6 = 0.4184E-06

A7 = -0.1382E-07

A8 = 0.2360E-09

A9 = -0.1636E-11

Multiple Correlation Coefficient = 0.999993; No. of Data Points = 211

T300/5208 - VF=61.8 - 0.01 CM/MIN

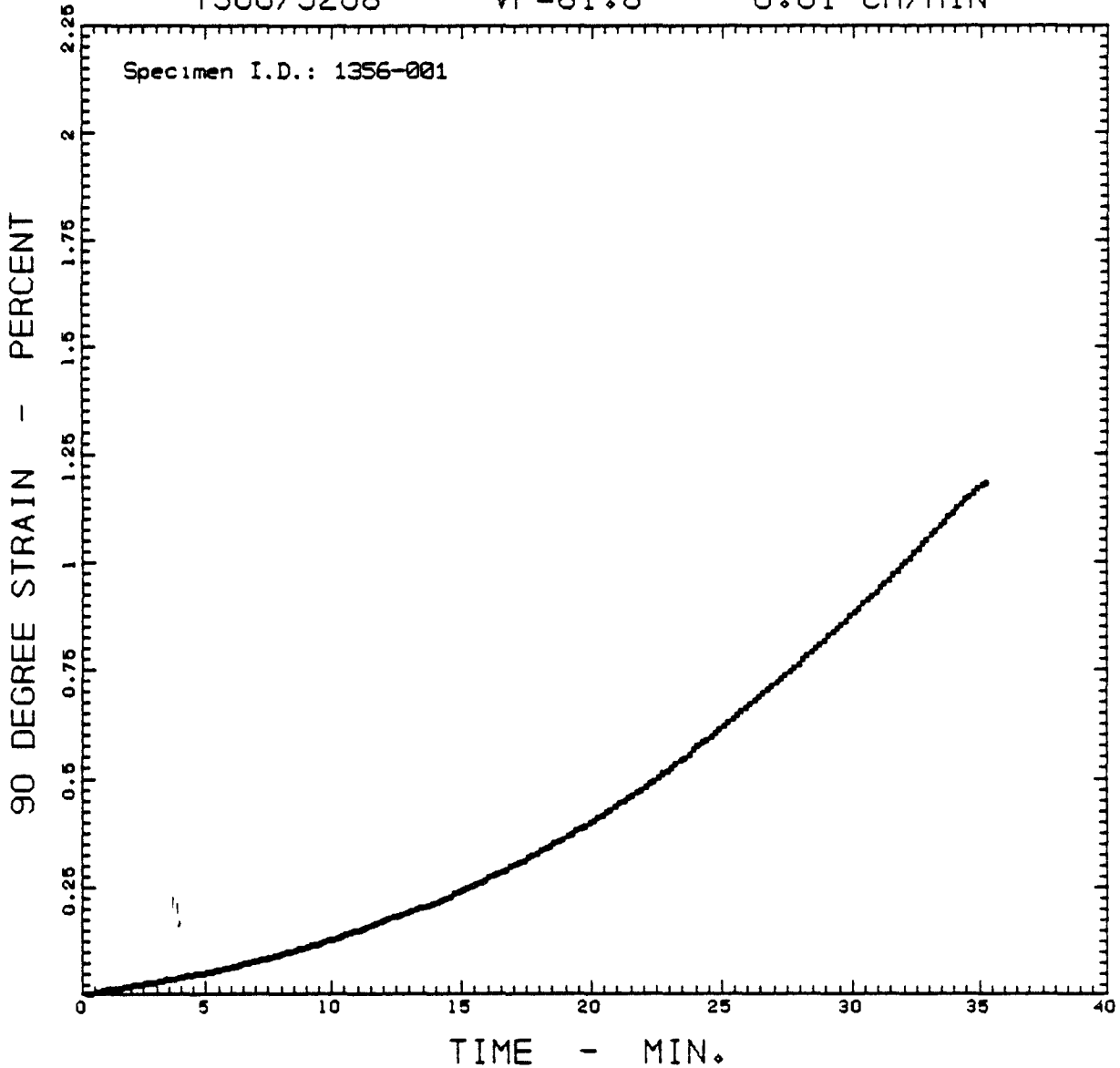

STRAIN = A0 + A1*TIME + A2*TIME^2 + ... + A9*TIME^9

where:

0.2294 < TIME < 35.2294

A0 = 0.7107E-04	A4 = 0.4789E-04	A7 = -0.1061E-07
A1 = 0.1054E-01	A5 = -0.5521E-05	A8 = 0.1794E-09
A2 = -0.5616E-04	A6 = 0.3271E-06	A9 = -0.1237E-11
A3 = -0.1359E-03		

Multiple Correlation Coefficient = 0.999992; No. of Data Points = 211

T300/5208 - VF=61.8 - 0.01 CM/MIN

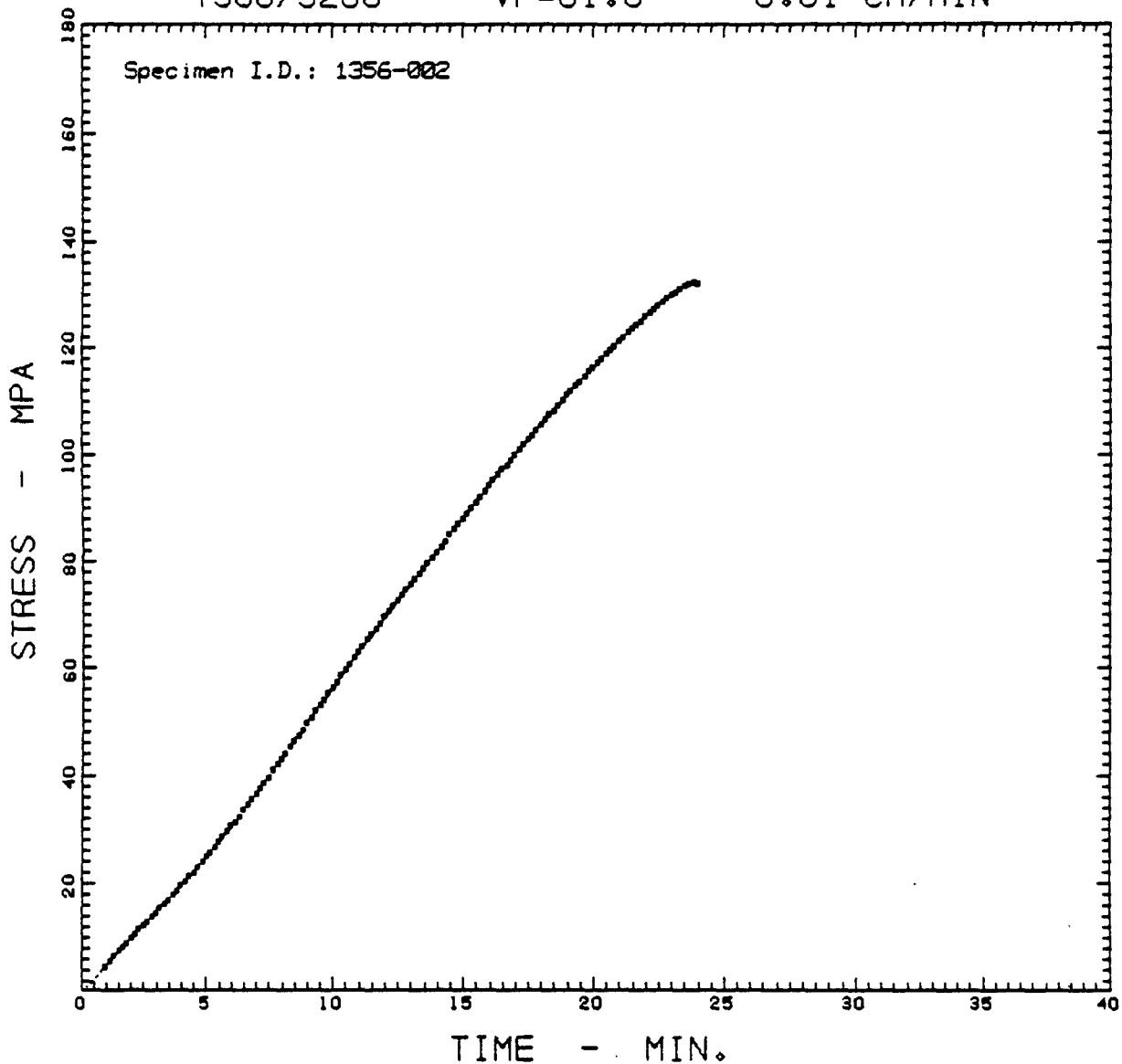

STRESS = A0 + A1*TIME + A2*TIME^2 + ... + A9*TIME^9

where:

0.9646 < TIME < 23.9613

A0 = -0.3827E+00

A1 = 0.5319E+01

A2 = 0.1608E+00

A3 = -0.2174E+00

A4 = 0.6718E-01

A5 = -0.9226E-02

A6 = 0.6845E-03

A7 = -0.2865E-04

A8 = 0.6390E-06

A9 = -0.5921E-08

Multiple Correlation Coefficient = 0.999997; No. of Data Points = 139

T300/5208 - VF=61.8 - 0.01 CM/MIN

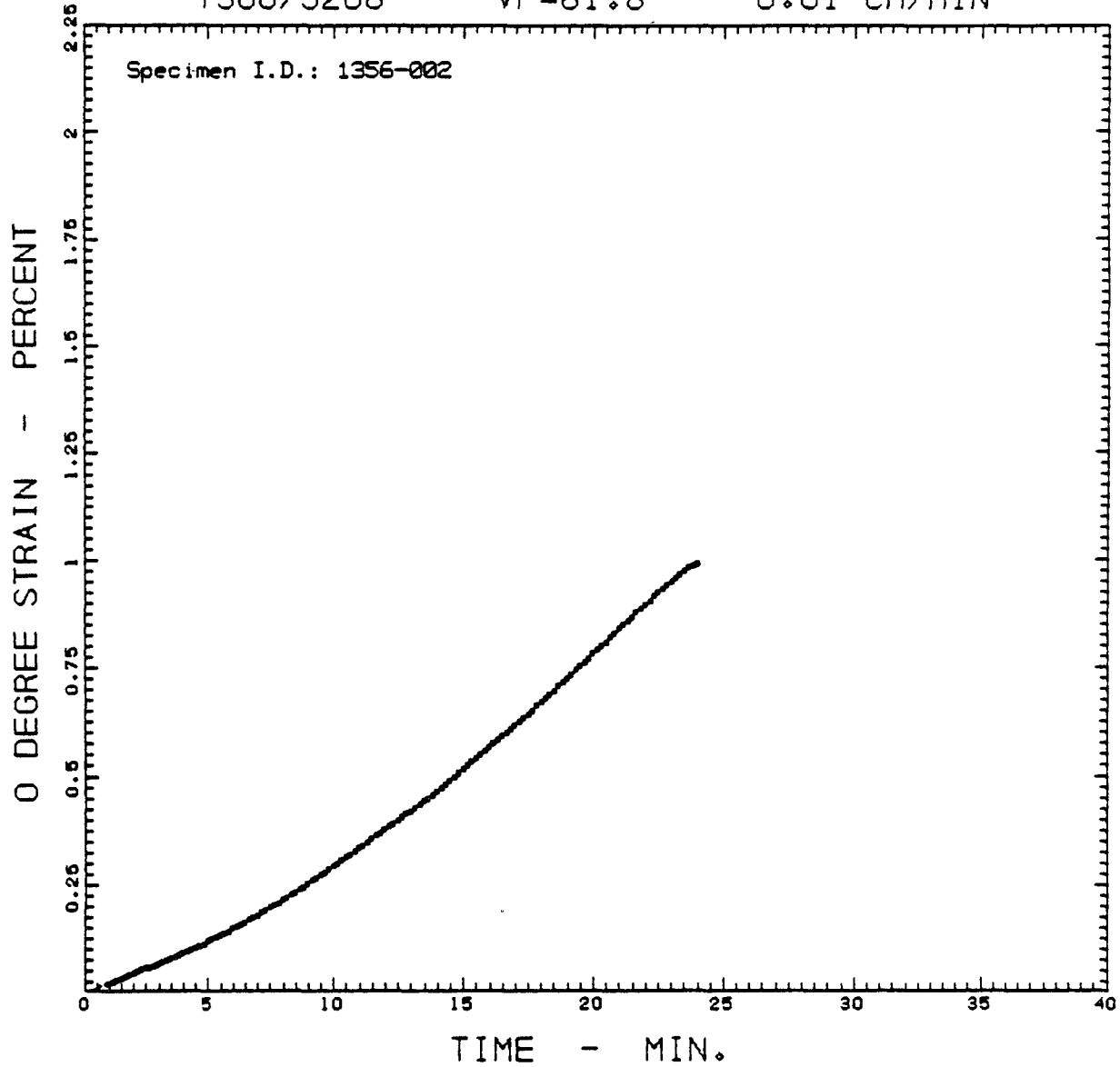

$$\text{STRAIN} = A_0 + A_1 \cdot \text{TIME} + A_2 \cdot \text{TIME}^2 + \dots + A_9 \cdot \text{TIME}^9$$

where:

$$0.9646 \leq \text{TIME} \leq 23.9613$$

A0 = 0.4703E-03	A4 = 0.6047E-03	A7 = -0.2154E-06
A1 = 0.1646E-01	A5 = -0.7439E-04	A8 = 0.4762E-08
A2 = 0.5949E-02	A6 = 0.5259E-05	A9 = -0.4410E-10
A3 = -0.2611E-02		

Multiple Correlation Coefficient = 0.999997; No. of Data Points = 139

T300/5208 - VF=61.8 - 0.01 CM/MIN

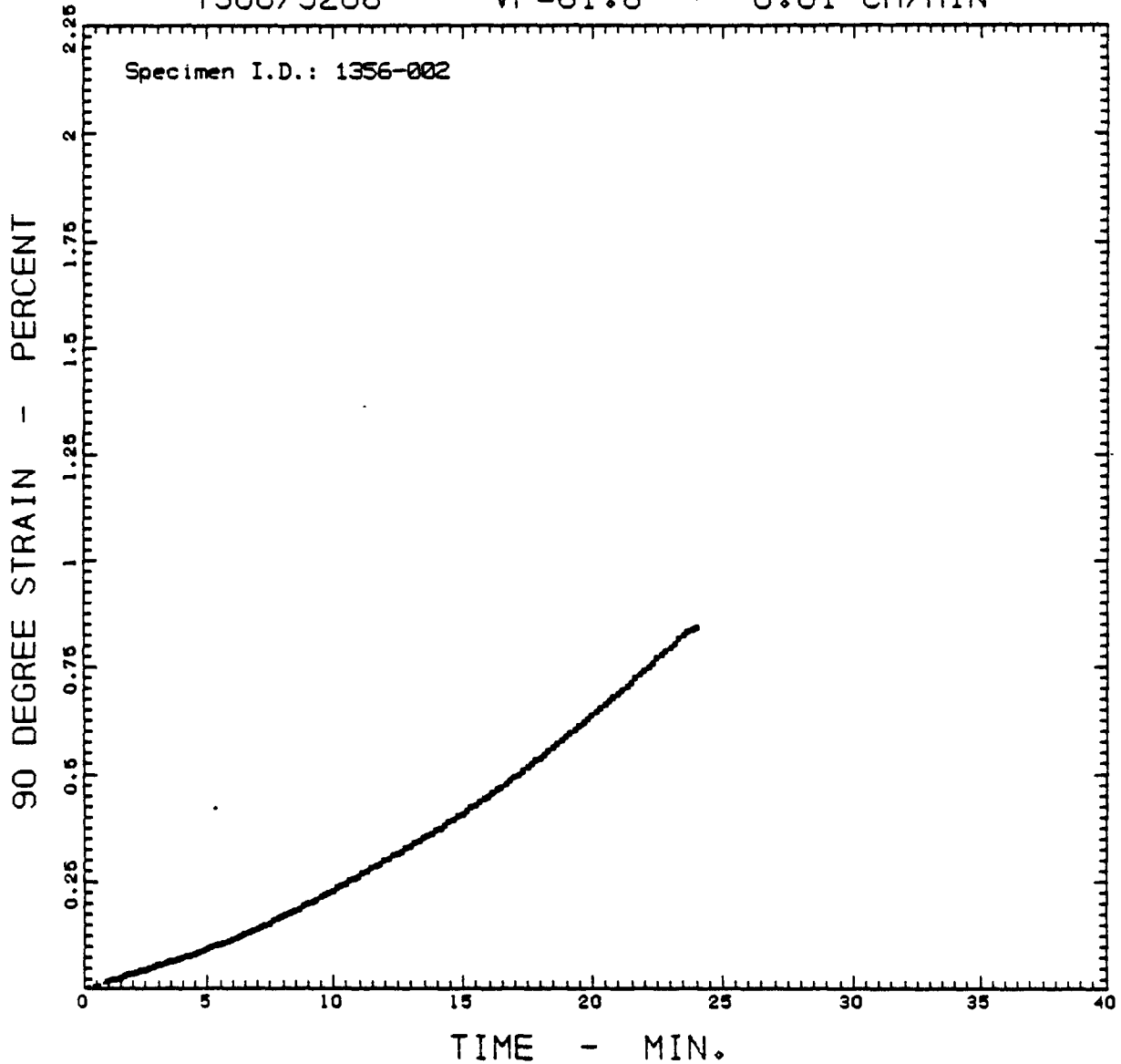

$$\text{STRAIN} = A_0 + A_1 \cdot \text{TIME} + A_2 \cdot \text{TIME}^2 + \dots + A_9 \cdot \text{TIME}^9$$

where:

$$0.9646 \leq \text{TIME} \leq 23.9613$$

$$A_0 = 0.2588E-02$$

$$A_1 = 0.1268E-01$$

$$A_2 = 0.5374E-02$$

$$A_3 = -0.2385E-02$$

$$A_4 = 0.5405E-03$$

$$A_5 = -0.6544E-04$$

$$A_6 = 0.4581E-05$$

$$A_7 = -0.1864E-06$$

$$A_8 = 0.4103E-08$$

$$A_9 = -0.3785E-10$$

Multiple Correlation Coefficient = 0.999996; No. of Data Points = 139

T300/5208 - VF=61.8 - 0.01 CM/MIN

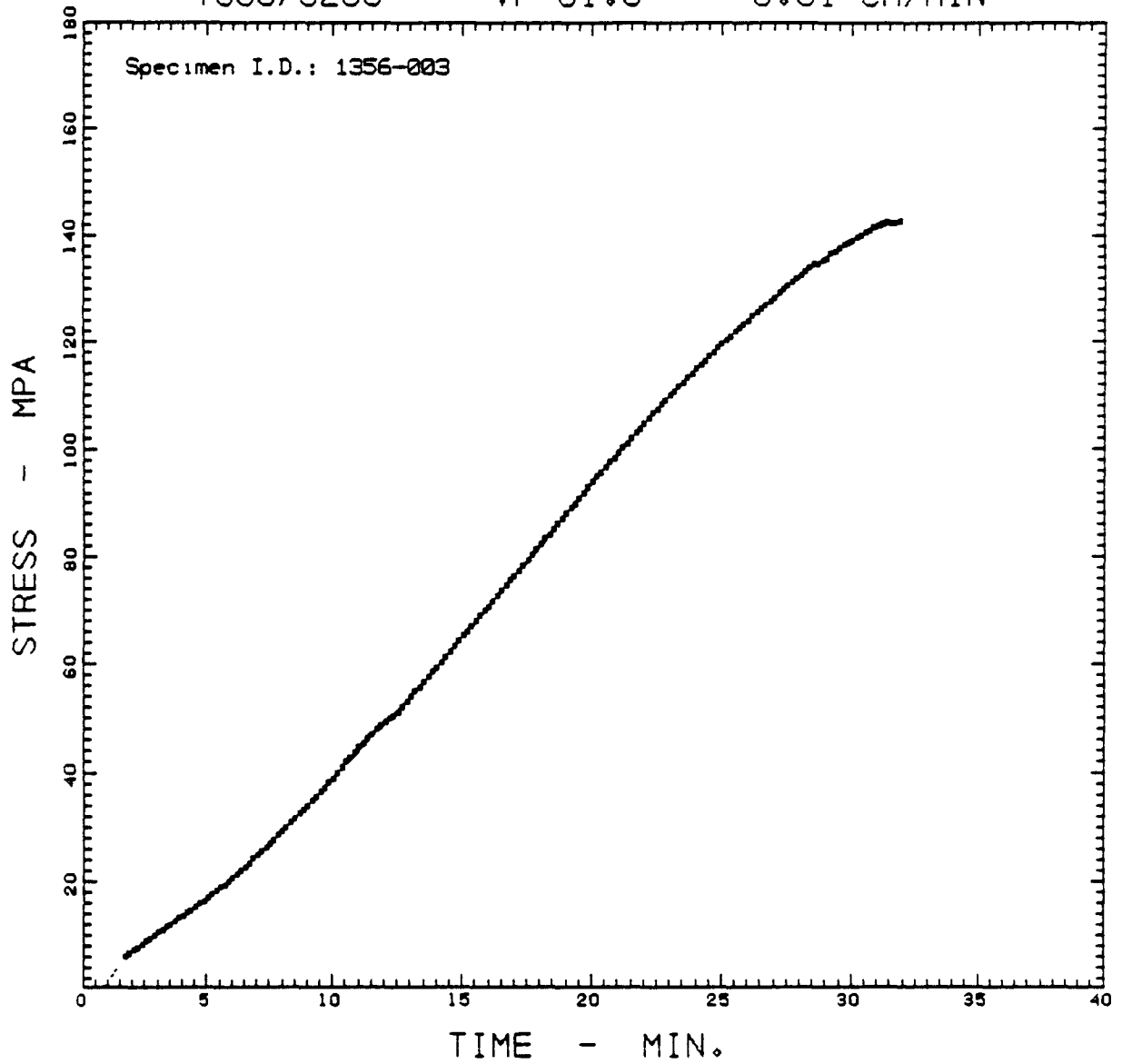

STRESS = A0 + A1*TIME + A2*TIME^2 + ... + A9*TIME^9

where:

1.7070 <= TIME <= 31.8736

A0 = -0.7782E+01

A1 = 0.1290E+02

A2 = -0.4207E+01

A3 = 0.8965E+00

A4 = -0.1050E+00

A5 = 0.7394E-02

A6 = -0.3198E-03

A7 = 0.8289E-05

A8 = -0.1180E-06

A9 = 0.7088E-09

Multiple Correlation Coefficient = 0.999983; No. of Data Points = 182

T300/5208 - VF=61.8 - 0.01 CM/MIN

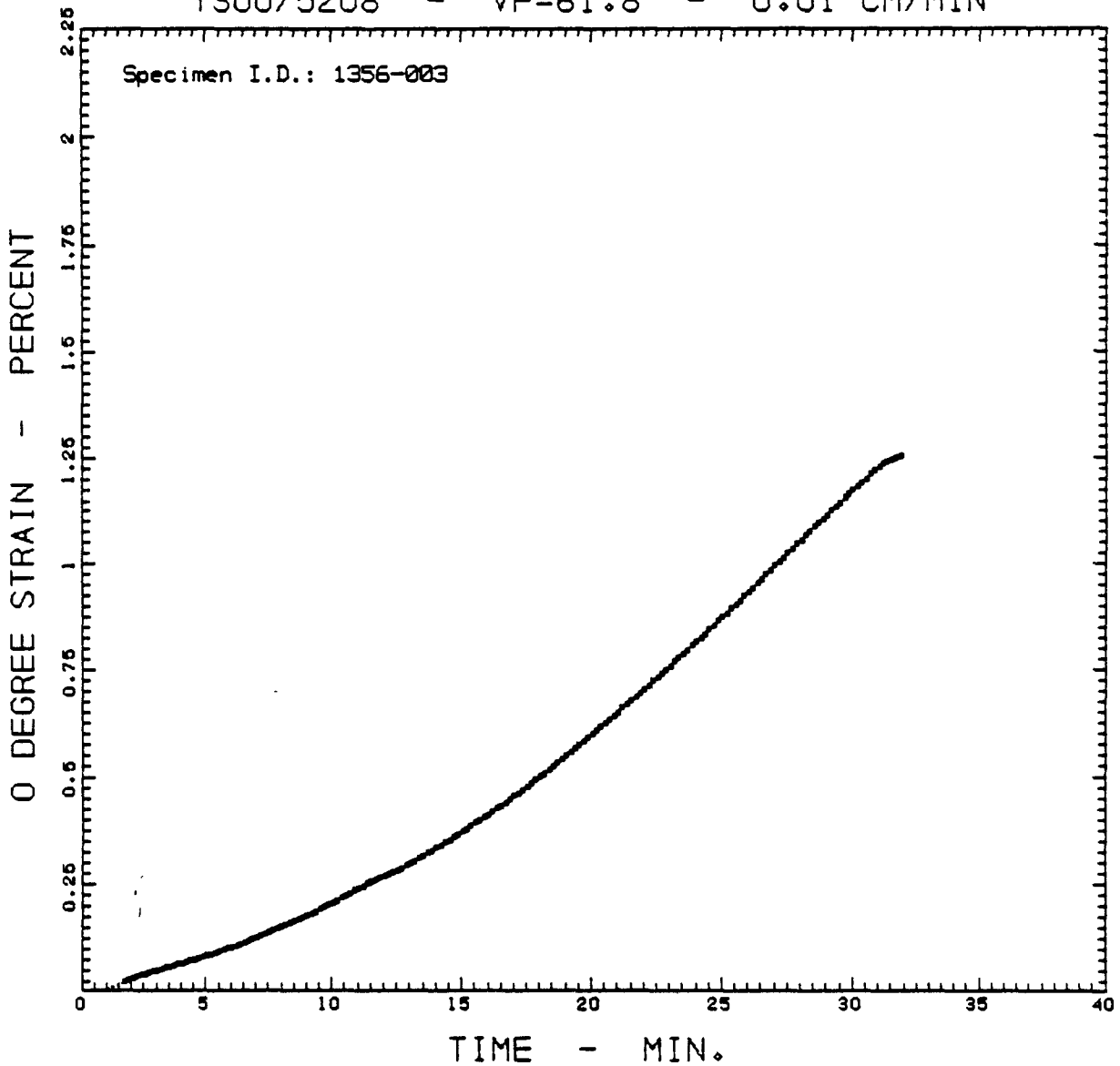

$$\text{STRAIN} = A_0 + A_1 \cdot \text{TIME} + A_2 \cdot \text{TIME}^2 + \dots + A_9 \cdot \text{TIME}^9$$

where:

$$1.7070 \leq \text{TIME} \leq 31.8736$$

A0 = -0.4868E-01	A4 = -0.5545E-03	A7 = 0.3729E-07
A1 = 0.7053E-01	A5 = 0.3764E-04	A8 = -0.4843E-09
A2 = -0.2317E-01	A6 = -0.1544E-05	A9 = 0.2572E-11
A3 = 0.4864E-02		

Multiple Correlation Coefficient = 0.999993; No. of Data Points = 182

T300/5208 - VF=61.8 - 0.01 CM/MIN

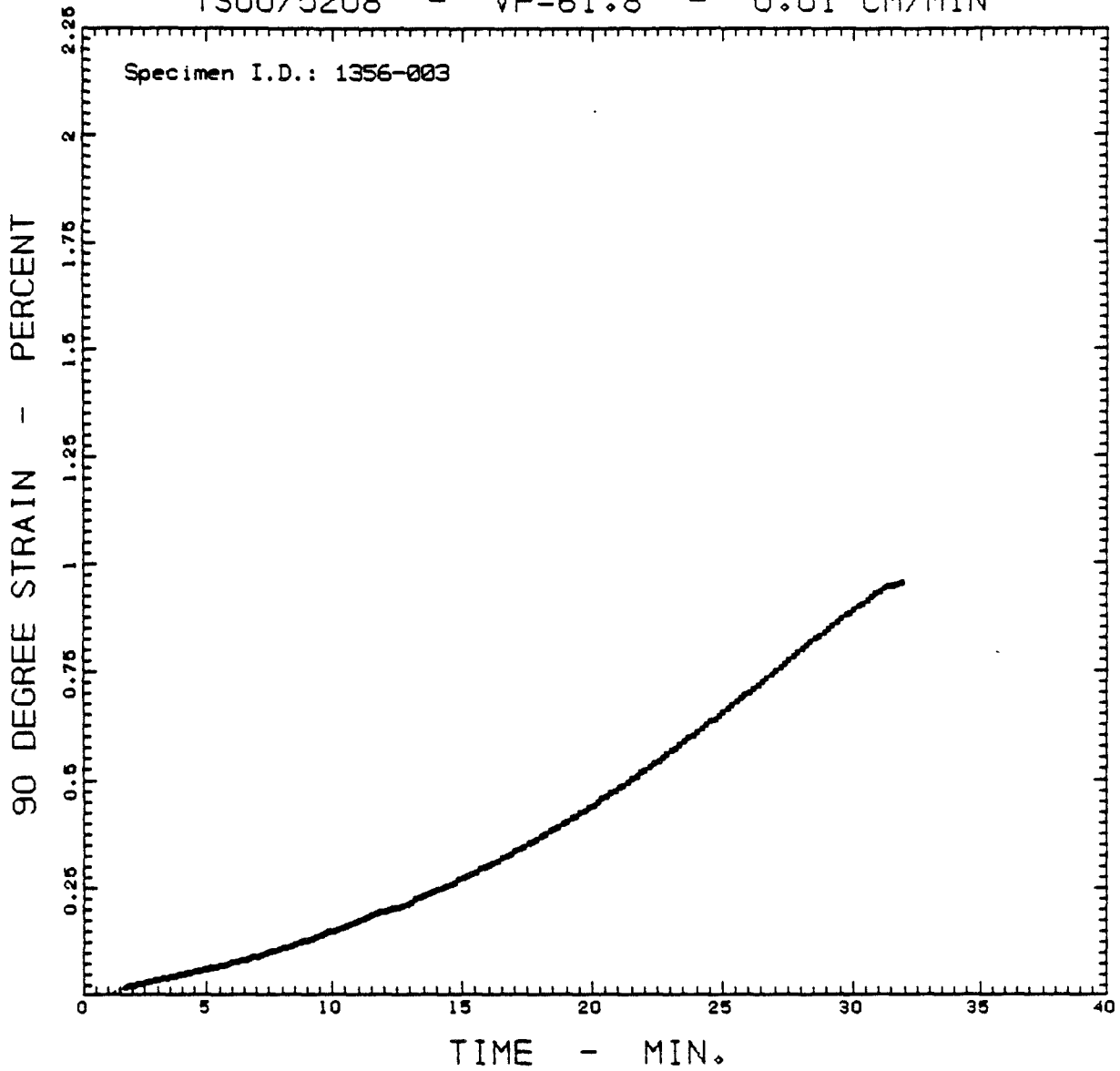

$$\text{STRAIN} = A_0 + A_1 \cdot \text{TIME} + A_2 \cdot \text{TIME}^2 + \dots + A_9 \cdot \text{TIME}^9$$

where:

$$1.7070 \leq \text{TIME} \leq 31.8736$$

$$A_0 = -0.3413E-01$$

$$A_1 = 0.5053E-01$$

$$A_2 = -0.1664E-01$$

$$A_3 = 0.3522E-02$$

$$A_4 = -0.4070E-03$$

$$A_5 = 0.2817E-04$$

$$A_6 = -0.1182E-05$$

$$A_7 = 0.2934E-07$$

$$A_8 = -0.3931E-09$$

$$A_9 = 0.2165E-11$$

Multiple Correlation Coefficient = 0.999991; No. of Data Points = 182

T300/5208 - VF=61.8 - 0.01 CM/MIN

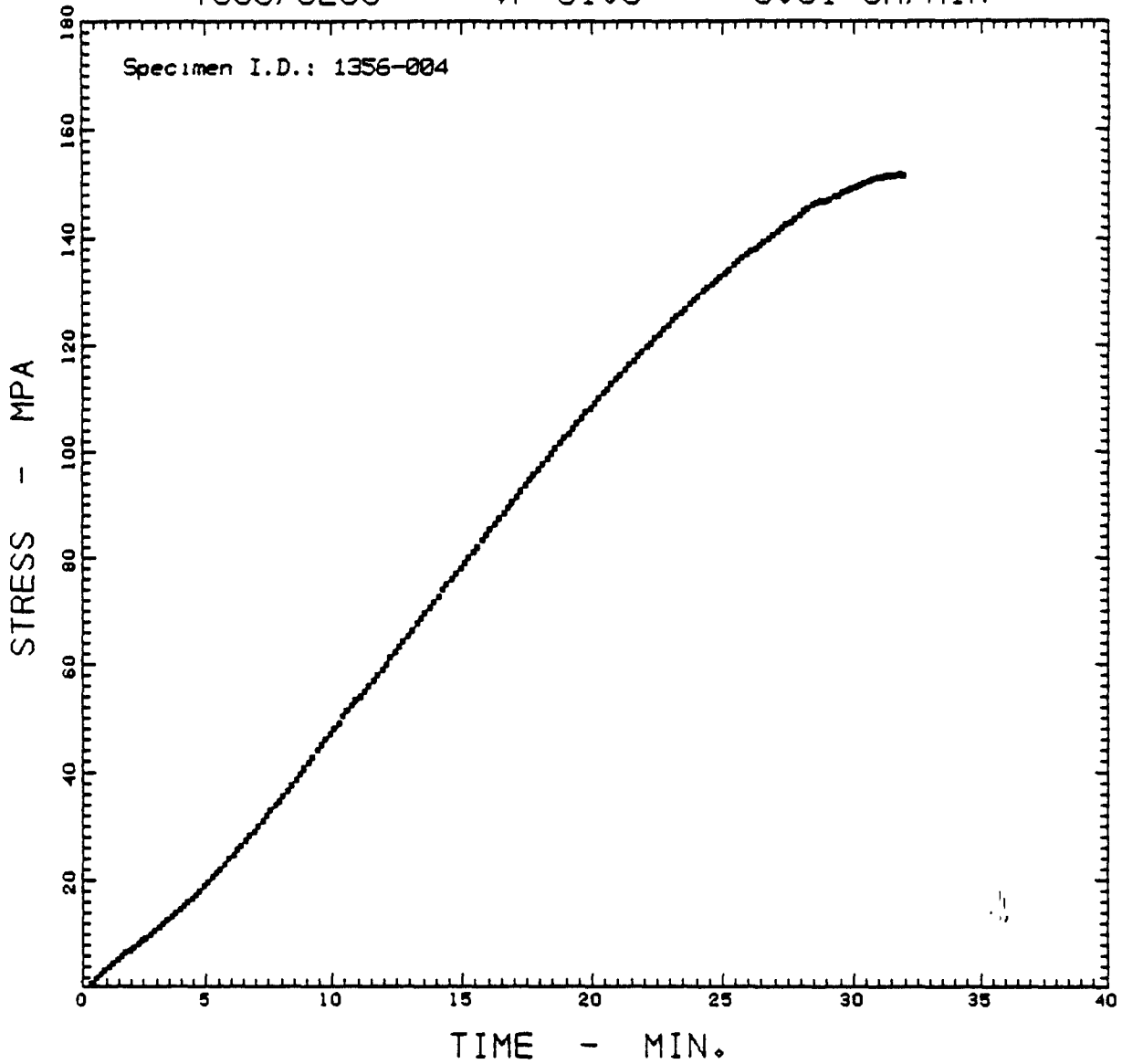

STRESS = A0 + A1*TIME + A2*TIME^2 + ... + A9*TIME^9

where:

0.3961 < TIME < 31.8961

A0 = -0.1389E+01

A1 = 0.6272E+01

A2 = -0.1638E+01

A3 = 0.4420E+00

A4 = -0.5741E-01

A5 = 0.4367E-02

A6 = -0.2032E-03

A7 = 0.5675E-05

A8 = -0.8727E-07

A9 = 0.5673E-09

Multiple Correlation Coefficient = 0.999995; No. of Data Points = 190

T300/5208 - VF=61.8 - 0.01 CM/MIN

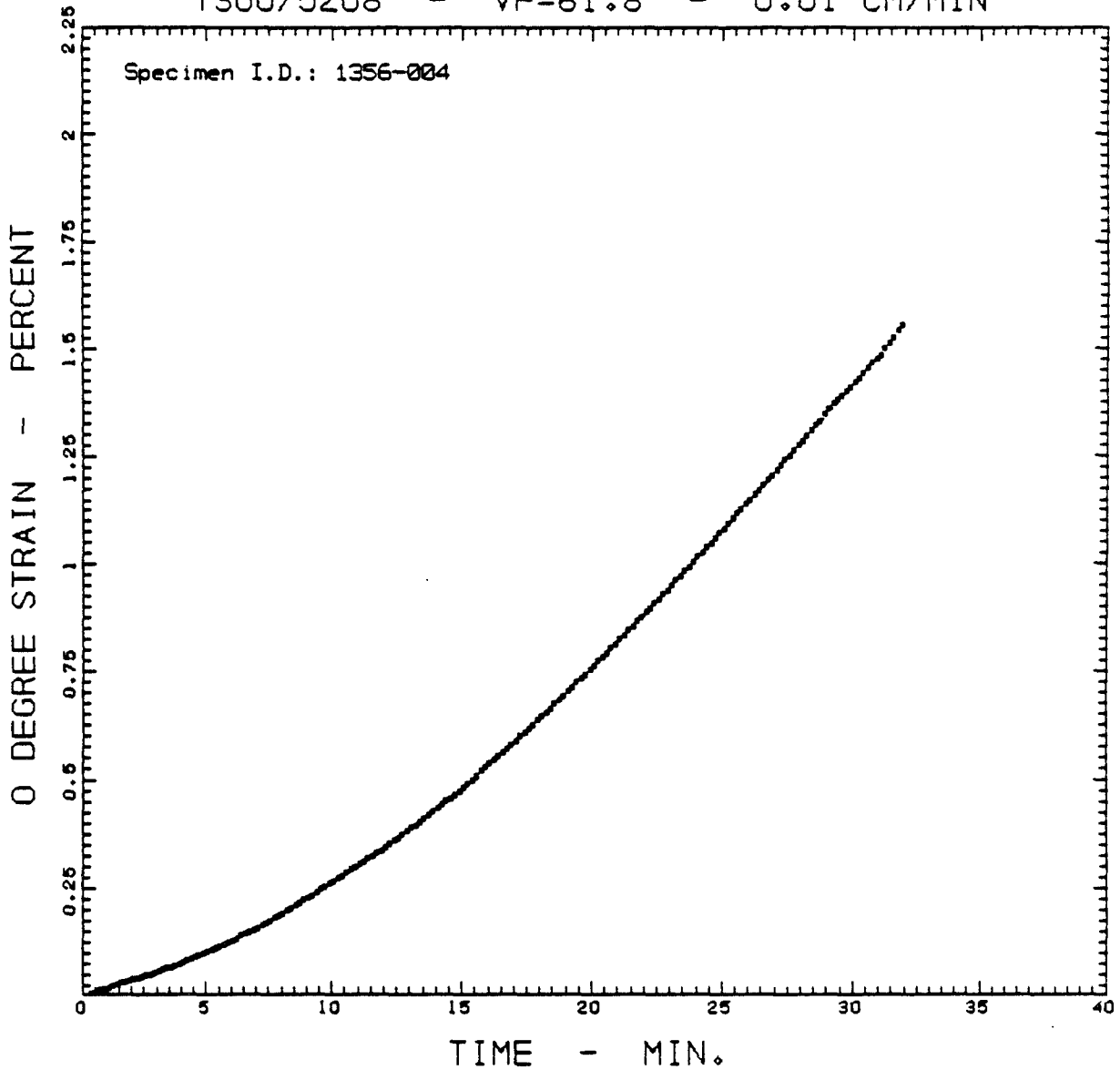

STRAIN = A0 + A1*TIME + A2*TIME^2 + ... + A9*TIME^9

where:

0.3961 =< TIME =< 31.8961

A0 = -0.8424E-02	A4 = -0.4055E-03	A7 = 0.4304E-07
A1 = 0.3533E-01	A5 = 0.3189E-04	A8 = -0.6704E-09
A2 = -0.1091E-01	A6 = -0.1518E-05	A9 = 0.4417E-11
A3 = 0.3025E-02		

Multiple Correlation Coefficient = 0.999996; No. of Data Points = 190

T300/5208 - VF=61.8 - 0.01 CM/MIN

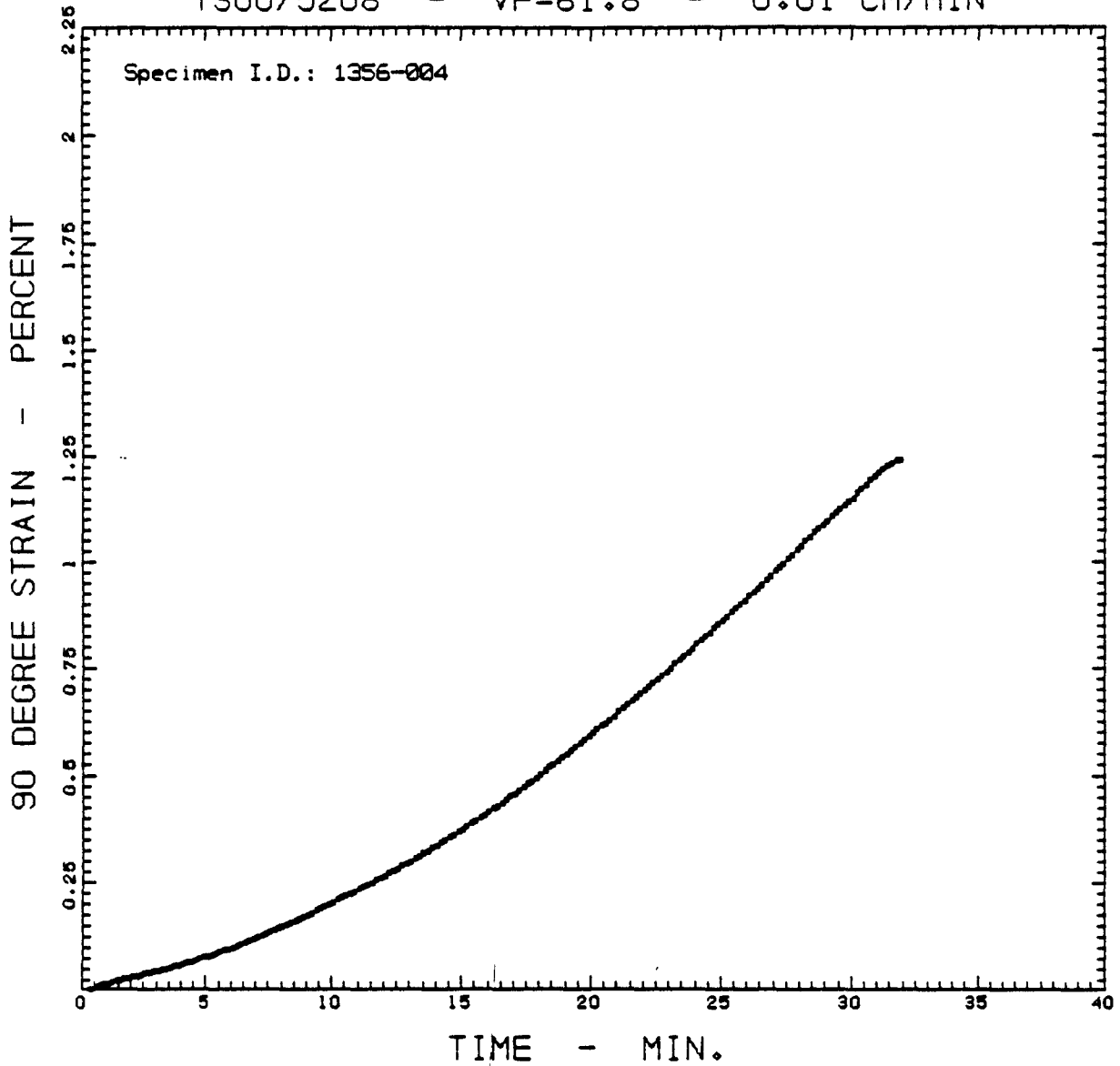

STRAIN = A0 + A1*TIME + A2*TIME^2 + ... + A9*TIME^9

where:

0.3961 < TIME < 31.8961

A0 = -0.5004E-02

A1 = 0.2480E-01

A2 = -0.6091E-02

A3 = 0.1536E-02

A4 = -0.1803E-03

A5 = 0.1229E-04

A6 = -0.4955E-06

A7 = 0.1146E-07

A8 = -0.1362E-09

A9 = 0.6053E-12

Multiple Correlation Coefficient = 0.999997; No. of Data Points = 190

T300/5208 - VF=61.8 - 0.01 CM/MIN

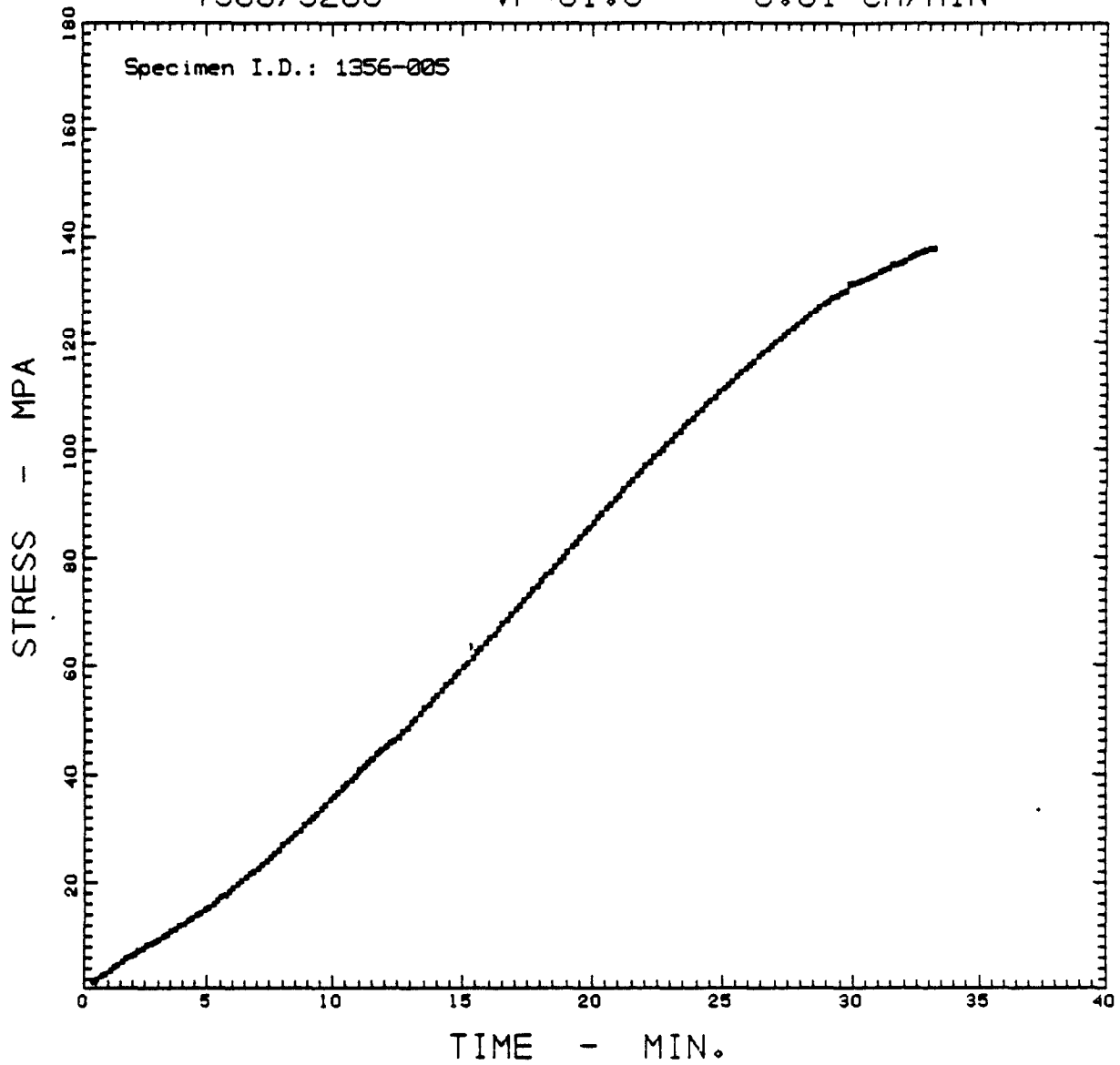

STRESS = A0 + A1*TIME + A2*TIME^2 + ... + A9*TIME^9

where:

0.3809 < TIME < 33.2142

A0 = -0.1219E+01

A1 = 0.6330E+01

A2 = -0.2034E+01

A3 = 0.5259E+00

A4 = -0.7001E-01

A5 = 0.5482E-02

A6 = -0.2596E-03

A7 = 0.7311E-05

A8 = -0.1124E-06

A9 = 0.7273E-09

Multiple Correlation Coefficient = 0.999989; No. of Data Points = 198

T300/5208 - VF=61.8 - 0.01 CM/MIN

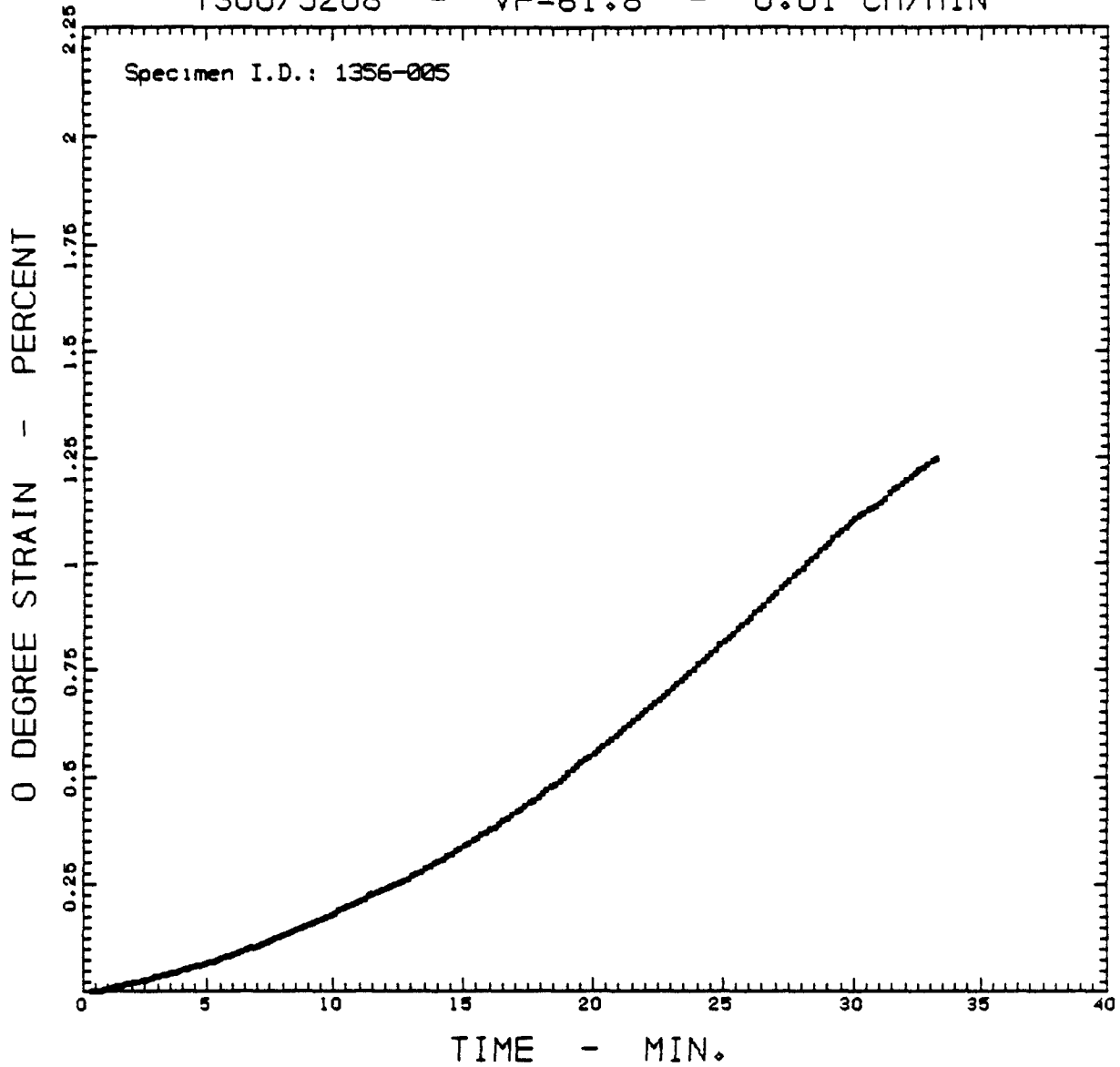

$$\text{STRAIN} = A0 + A1*\text{TIME} + A2*\text{TIME}^2 + \dots + A9*\text{TIME}^9$$

where:

$$0.3809 \leq \text{TIME} \leq 33.2142$$

A0 = -0.1393E-01	A4 = -0.4585E-03	A7 = 0.5226E-07
A1 = 0.3169E-01	A5 = 0.3726E-04	A8 = -0.8194E-09
A2 = -0.1178E-01	A6 = -0.1815E-05	A9 = 0.5388E-11
A3 = 0.3284E-02		

Multiple Correlation Coefficient = 0.999986; No. of Data Points = 198

T300/5208 - VF=61.8 - 0.01 CM/MIN

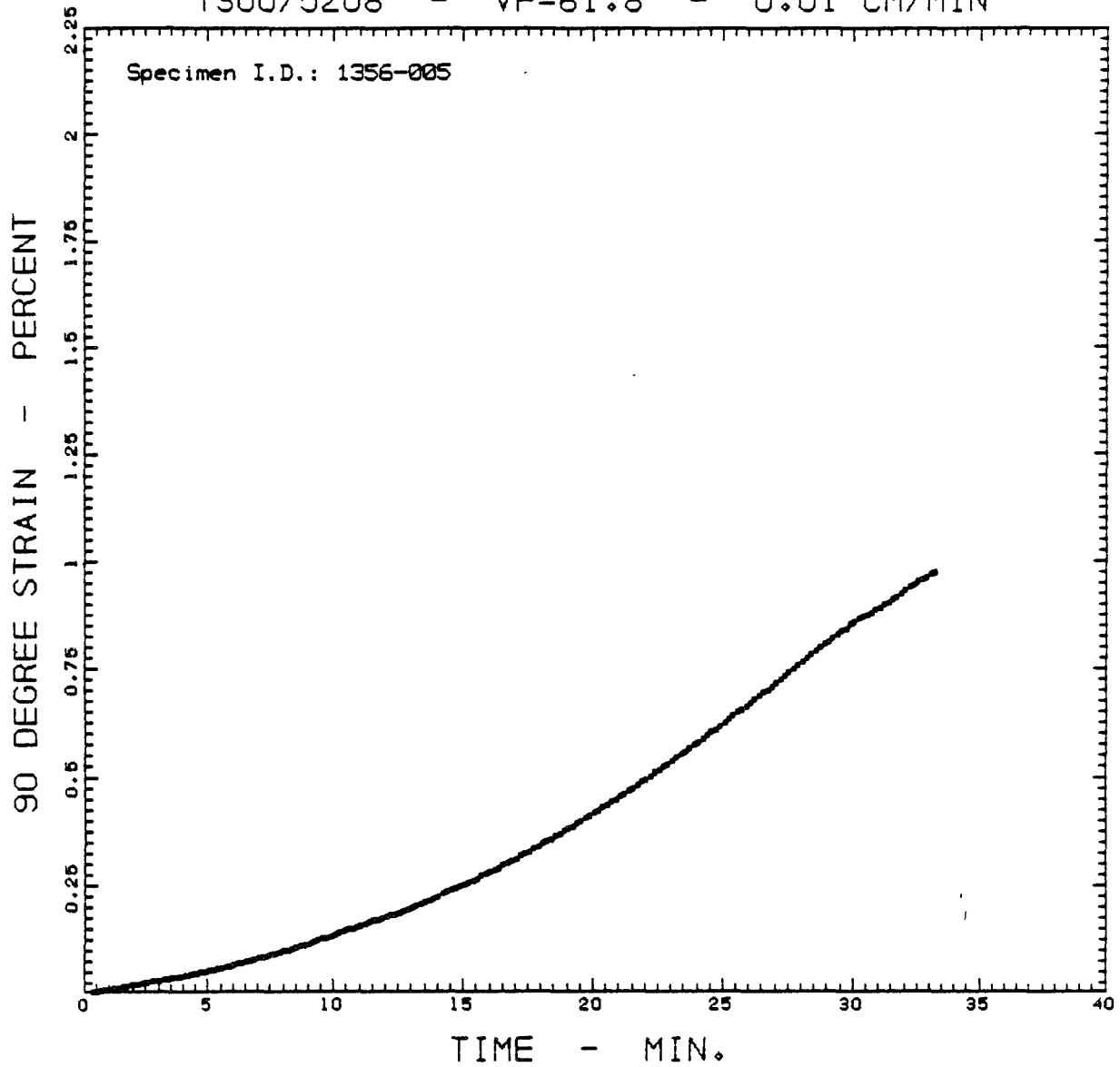

STRAIN = A0 + A1*TIME + A2*TIME^2 + ... + A9*TIME^9

where:

0.3809 < TIME < 33.2142

A0 = -0.9714E-02

A1 = 0.2682E-01

A2 = -0.1054E-01

A3 = 0.2868E-02

A4 = -0.3985E-03

A5 = 0.3240E-04

A6 = -0.1582E-05

A7 = 0.4571E-07

A8 = -0.7192E-09

A9 = 0.4743E-11

Multiple Correlation Coefficient = 0.999984; No. of Data Points = 198

T300/5208 - VF=60.1 - 0.01 CM/MIN

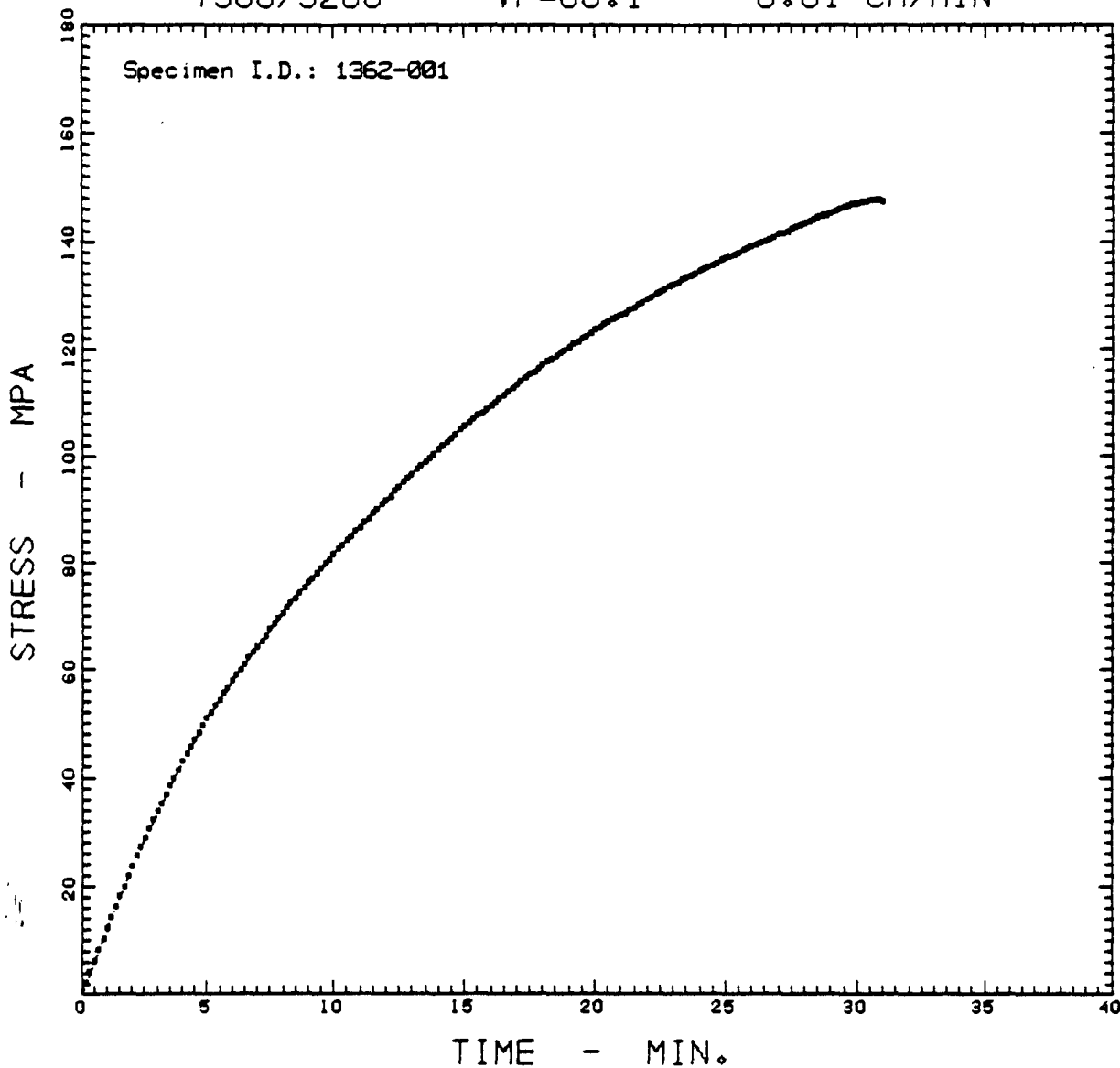

STRESS = A0 + A1*TIME + A2*TIME^2 + ... + A9*TIME^9

where:

0.1741 < TIME < 31.0075

A0 = -0.1070E+00

A1 = 0.1257E+02

A2 = -0.9669E-01

A3 = -0.1859E+00

A4 = 0.3337E-01

A5 = -0.2936E-02

A6 = 0.1494E-03

A7 = -0.4478E-05

A8 = 0.7354E-07

A9 = -0.5116E-09

Multiple Correlation Coefficient = 0.999997; No. of Data Points = 186

T300/5208 - VF=60.1 - 0.01 CM/MIN

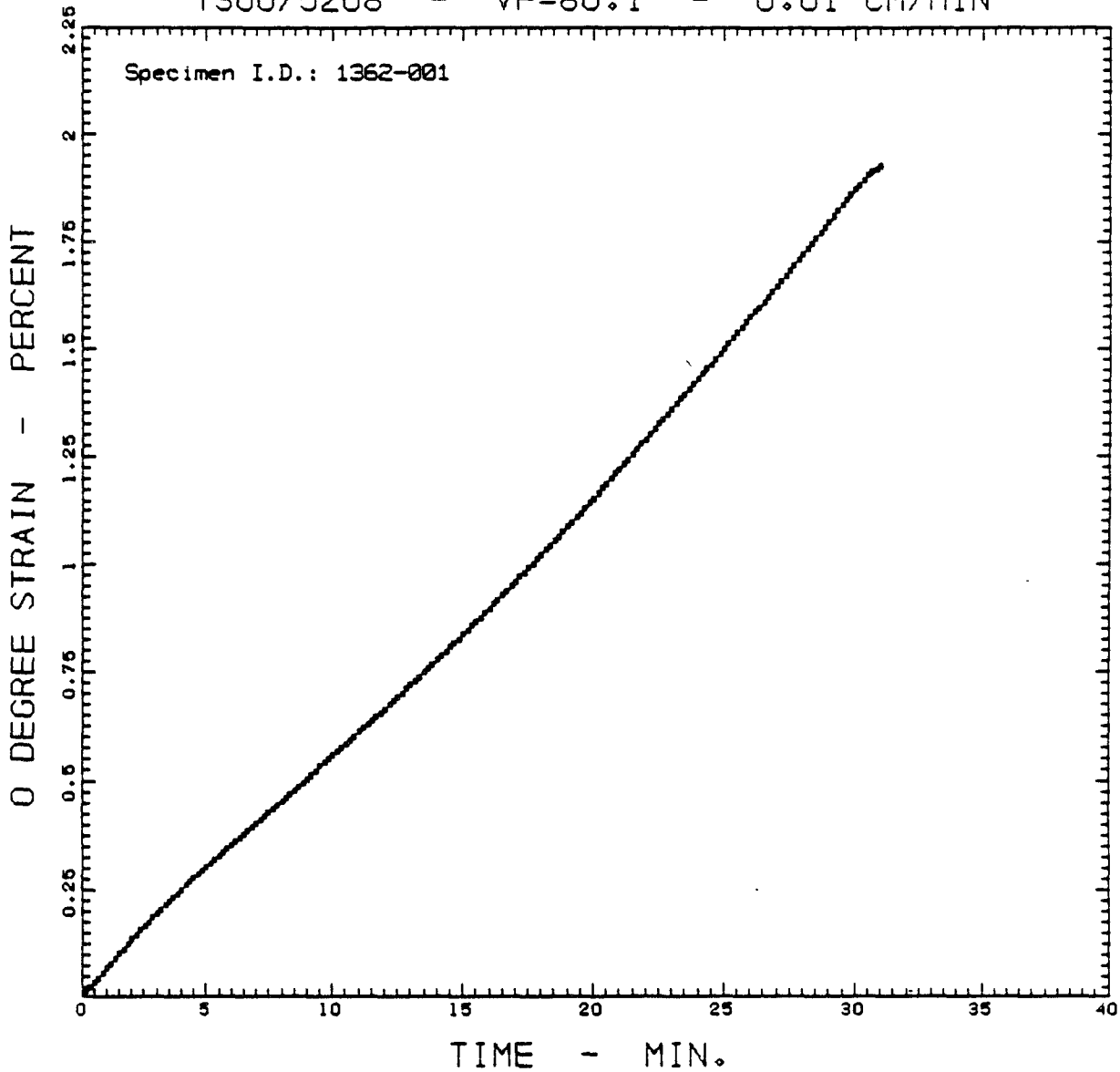

$$\text{STRAIN} = A_0 + A_1 \cdot \text{TIME} + A_2 \cdot \text{TIME}^2 + \dots + A_9 \cdot \text{TIME}^9$$

where:

$$0.1741 \leq \text{TIME} \leq 31.0075$$

$$A_0 = 0.1012E-02$$

$$A_1 = 0.6599E-01$$

$$A_2 = 0.2225E-02$$

$$A_3 = -0.1563E-02$$

$$A_4 = 0.2765E-03$$

$$A_5 = -0.2513E-04$$

$$A_6 = 0.1339E-05$$

$$A_7 = -0.4221E-07$$

$$A_8 = 0.7285E-09$$

$$A_9 = -0.5309E-11$$

Multiple Correlation Coefficient = 0.999998; No. of Data Points = 186

T300/5208 - VF=60.1 - 0.01 CM/MIN

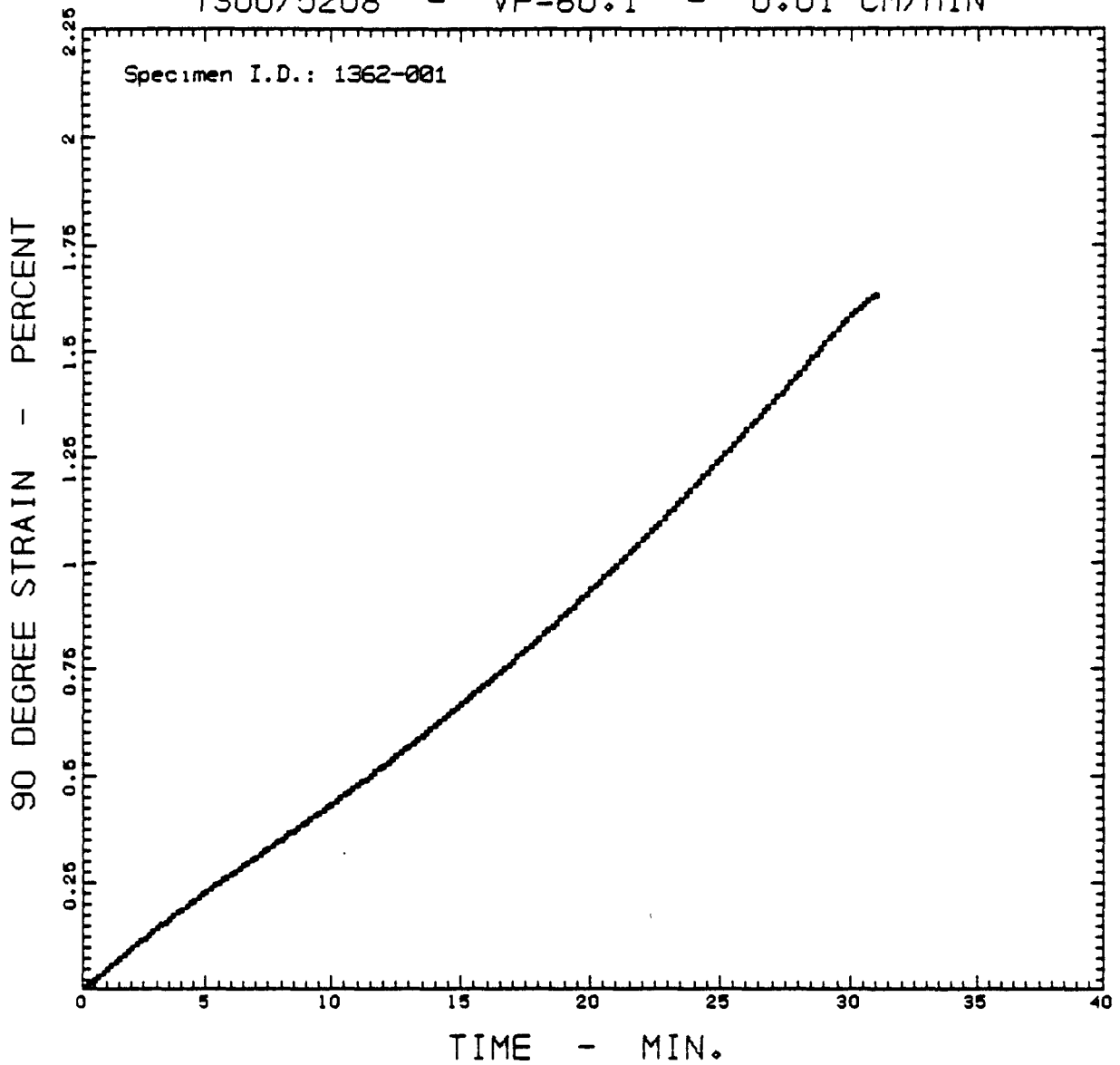

STRAIN = A0 + A1*TIME + A2*TIME^2 + ... + A9*TIME^9

where:

0.1741 < TIME < 31.0075

A0 = -0.3983E-02	A4 = 0.2299E-03	A7 = -0.3801E-07
A1 = 0.4929E-01	A5 = -0.2140E-04	A8 = 0.6724E-09
A2 = 0.2225E-02	A6 = 0.1174E-05	A9 = -0.5006E-11
A3 = -0.1292E-02		

Multiple Correlation Coefficient = 0.999999; No. of Data Points = 186

T300/5208 - VF=61.8 - 0.01 CM/MIN

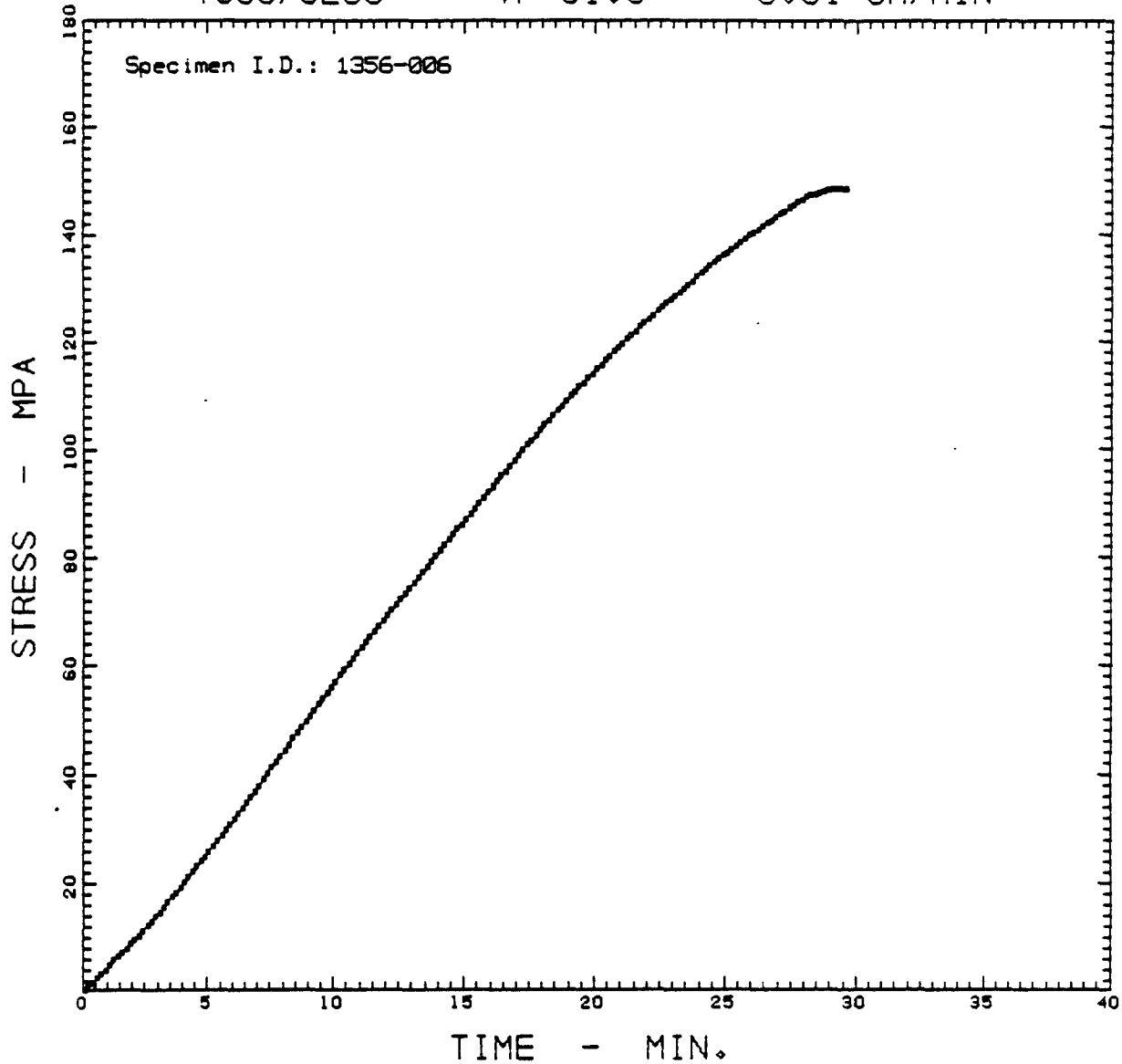

$$\text{STRESS} = A_0 + A_1 \cdot \text{TIME} + A_2 \cdot \text{TIME}^2 + \dots + A_9 \cdot \text{TIME}^9$$

where:

$$0.0751 \leq \text{TIME} \leq 29.5751$$

A0 = -0.1554E+00	A4 = -0.6948E-02	A7 = -0.1270E-05
A1 = 0.4640E+01	A5 = 0.1954E-03	A8 = 0.3594E-07
A2 = -0.6771E-01	A6 = 0.1453E-04	A9 = -0.3621E-09
A3 = 0.6201E-01		

Multiple Correlation Coefficient = 0.999998; No. of Data Points = 178

T300/5208 - VF=61.8 - 0.01 CM/MIN

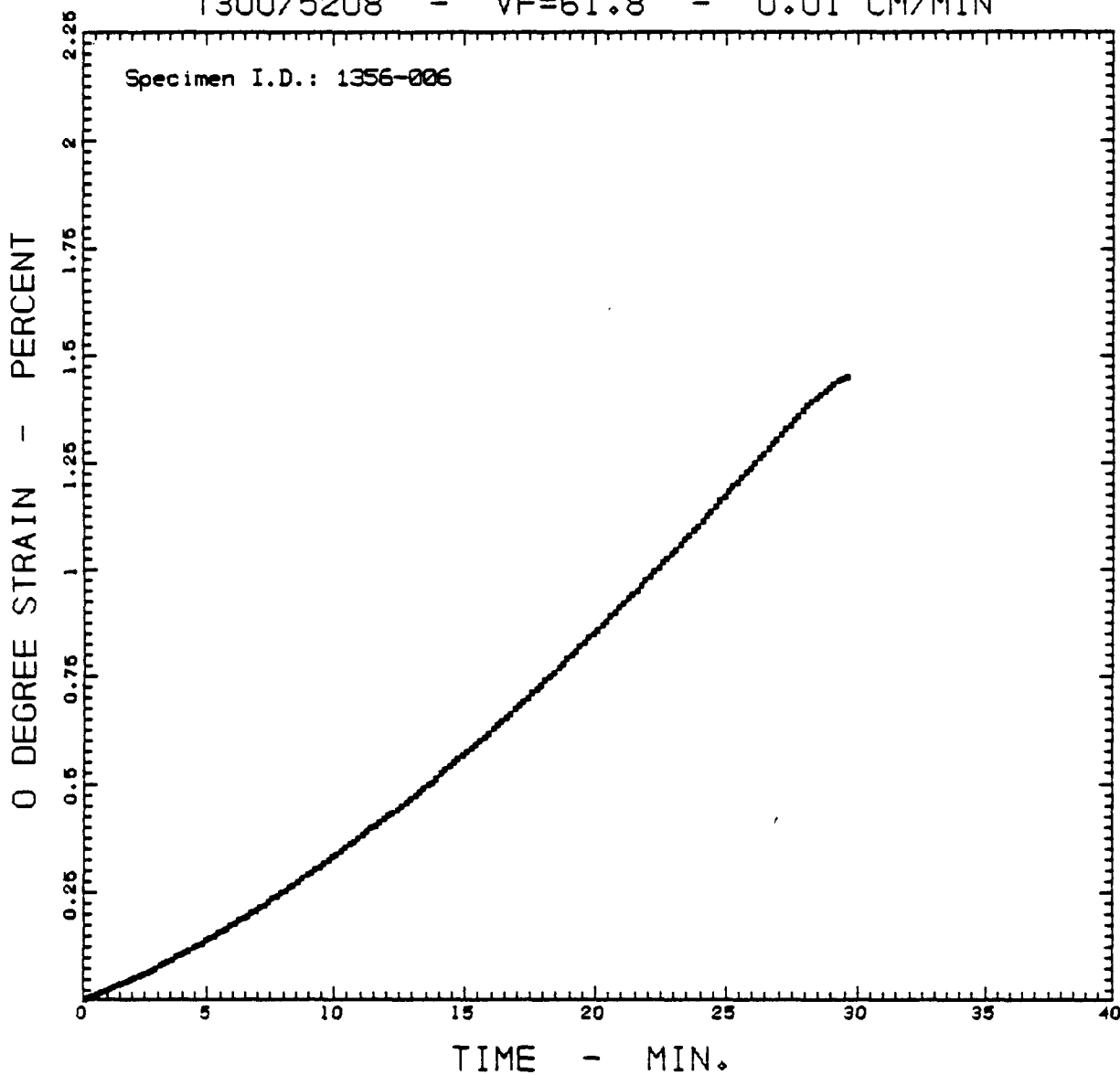

$$\text{STRAIN} = A_0 + A_1 \cdot \text{TIME} + A_2 \cdot \text{TIME}^2 + \dots + A_9 \cdot \text{TIME}^9$$

where:

$$0.0751 \leq \text{TIME} \leq 29.5751$$

A0 = -0.3099E-04	A4 = 0.1722E-04	A7 = -0.2134E-07
A1 = 0.2438E-01	A5 = -0.4972E-05	A8 = 0.4847E-09
A2 = 0.2476E-03	A6 = 0.4659E-06	A9 = -0.4376E-11
A3 = 0.9427E-04		

Multiple Correlation Coefficient = 0.999999; No. of Data Points = 178

T300/5208 - VF=61.8 - 0.01 CM/MIN

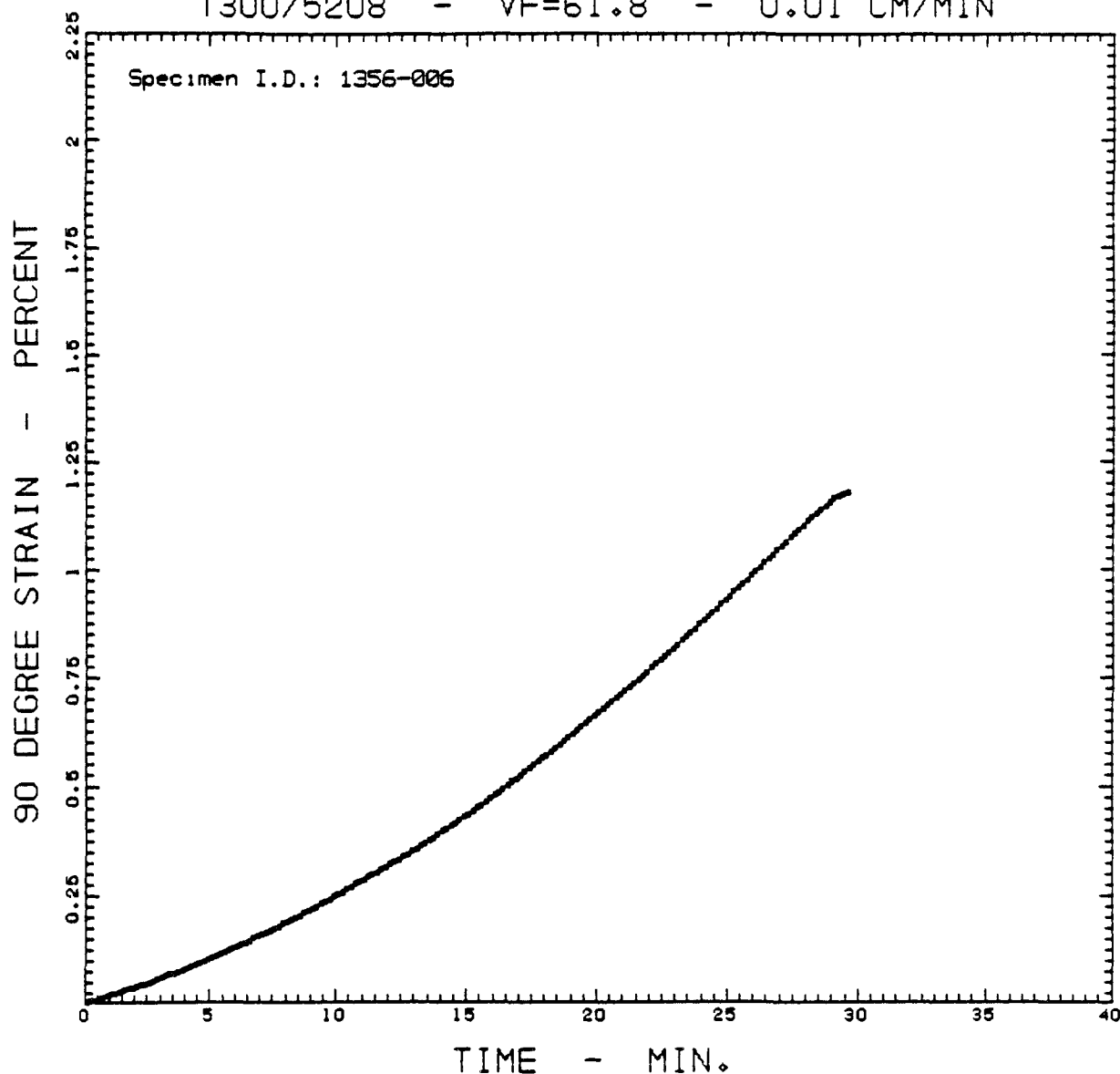

STRAIN = A0 + A1*TIME + A2*TIME^2 + ... + A9*TIME^9

where:

0.0751 < TIME < 29.5751

A0 = 0.1560E-03	A4 = 0.3306E-04	A7 = -0.2287E-07
A1 = 0.1887E-01	A5 = -0.6372E-05	A8 = 0.5009E-09
A2 = -0.1433E-05	A6 = 0.5301E-06	A9 = -0.4412E-11
A3 = 0.2132E-04		

Multiple Correlation Coefficient = 0.999999; No. of Data Points = 178

T300/5208 - VF=60.1 - 0.01 CM/MIN

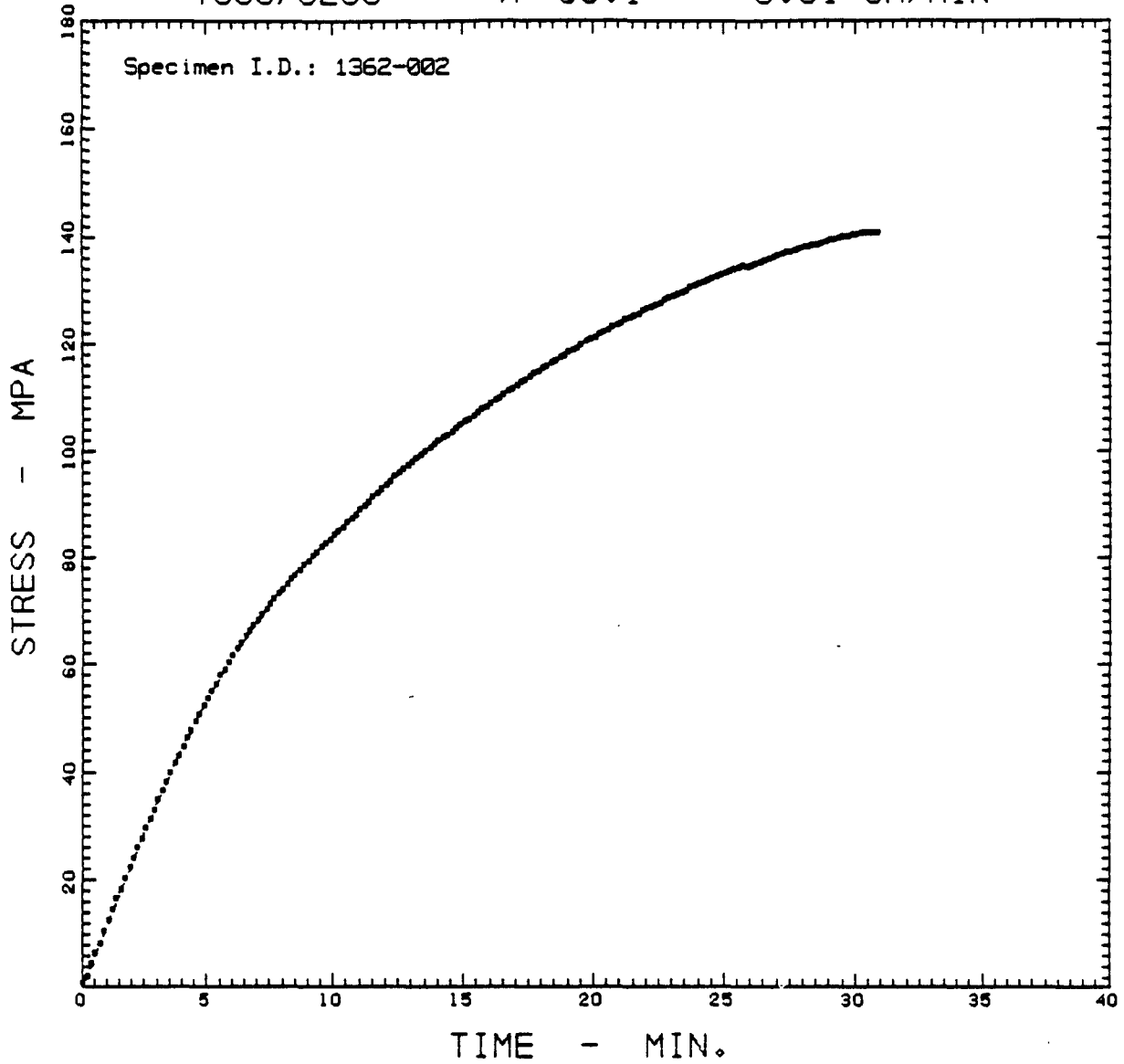

$$\text{STRESS} = A_0 + A_1 \cdot \text{TIME} + A_2 \cdot \text{TIME}^2 + \dots + A_9 \cdot \text{TIME}^9$$

where:

$$0.0466 \leq \text{TIME} \leq 30.8799$$

A0 = 0.3743E+00	A4 = 0.4858E-01	A7 = -0.3921E-05
A1 = 0.1061E+02	A5 = -0.3457E-02	A8 = 0.5731E-07
A2 = 0.1050E+01	A6 = 0.1496E-03	A9 = -0.3591E-09
A3 = -0.3829E+00		

Multiple Correlation Coefficient = 0.999987; No. of Data Points = 186

T300/5208 - VF=60.1 - 0.01 CM/MIN

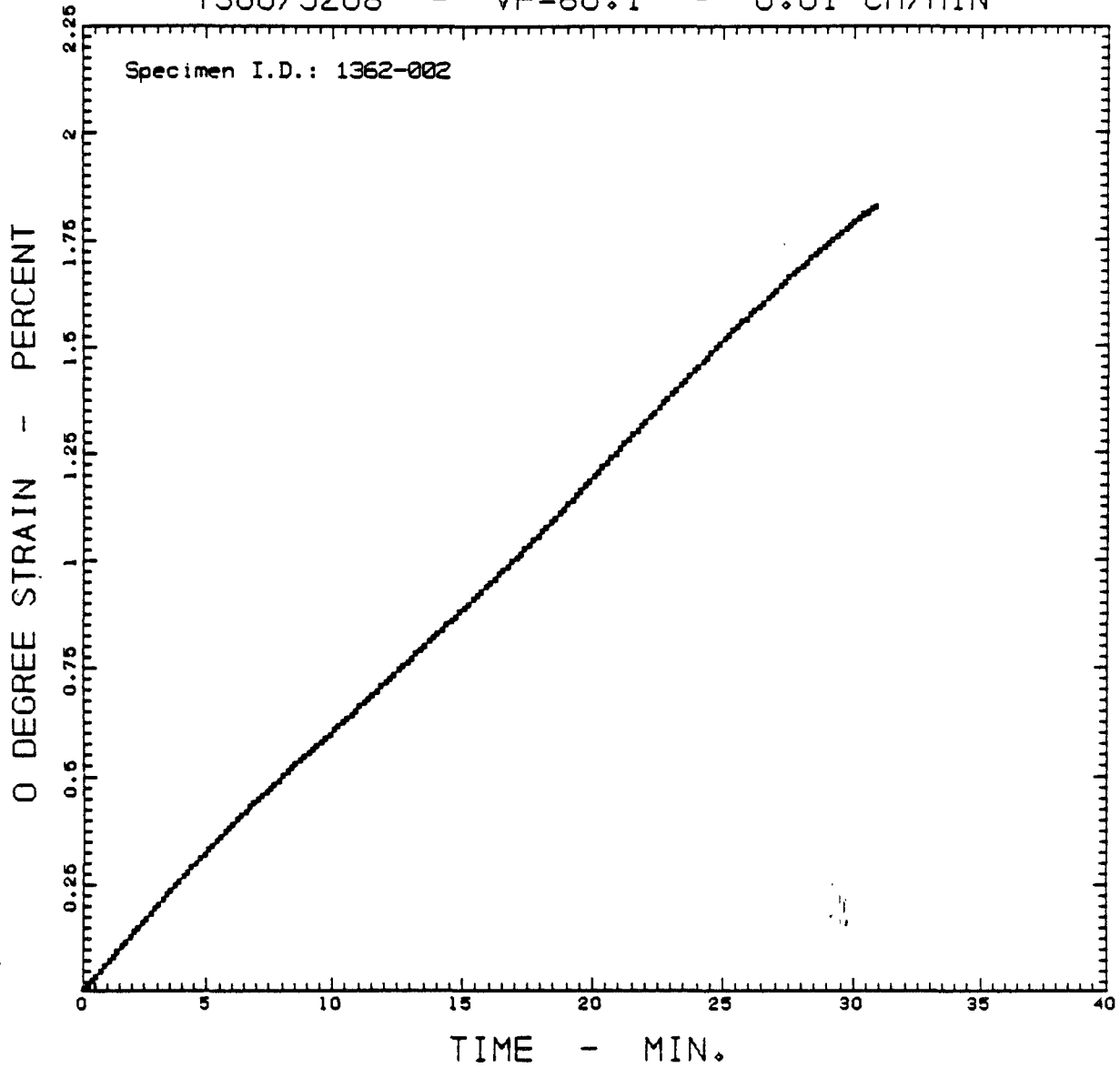

STRAIN = A0 + A1*TIME + A2*TIME^2 + ... + A9*TIME^9

where:

0.0466 < TIME < 30.8799

A0 = 0.3669E-02

A1 = 0.5804E-01

A2 = 0.6416E-02

A3 = -0.1747E-02

A4 = 0.2040E-03

A5 = -0.1313E-04

A6 = 0.4995E-06

A7 = -0.1099E-07

A8 = 0.1254E-09

A9 = -0.5398E-12

Multiple Correlation Coefficient = 0.999994; No. of Data Points = 186

T300/5208 - VF=60.1 - 0.01 CM/MIN

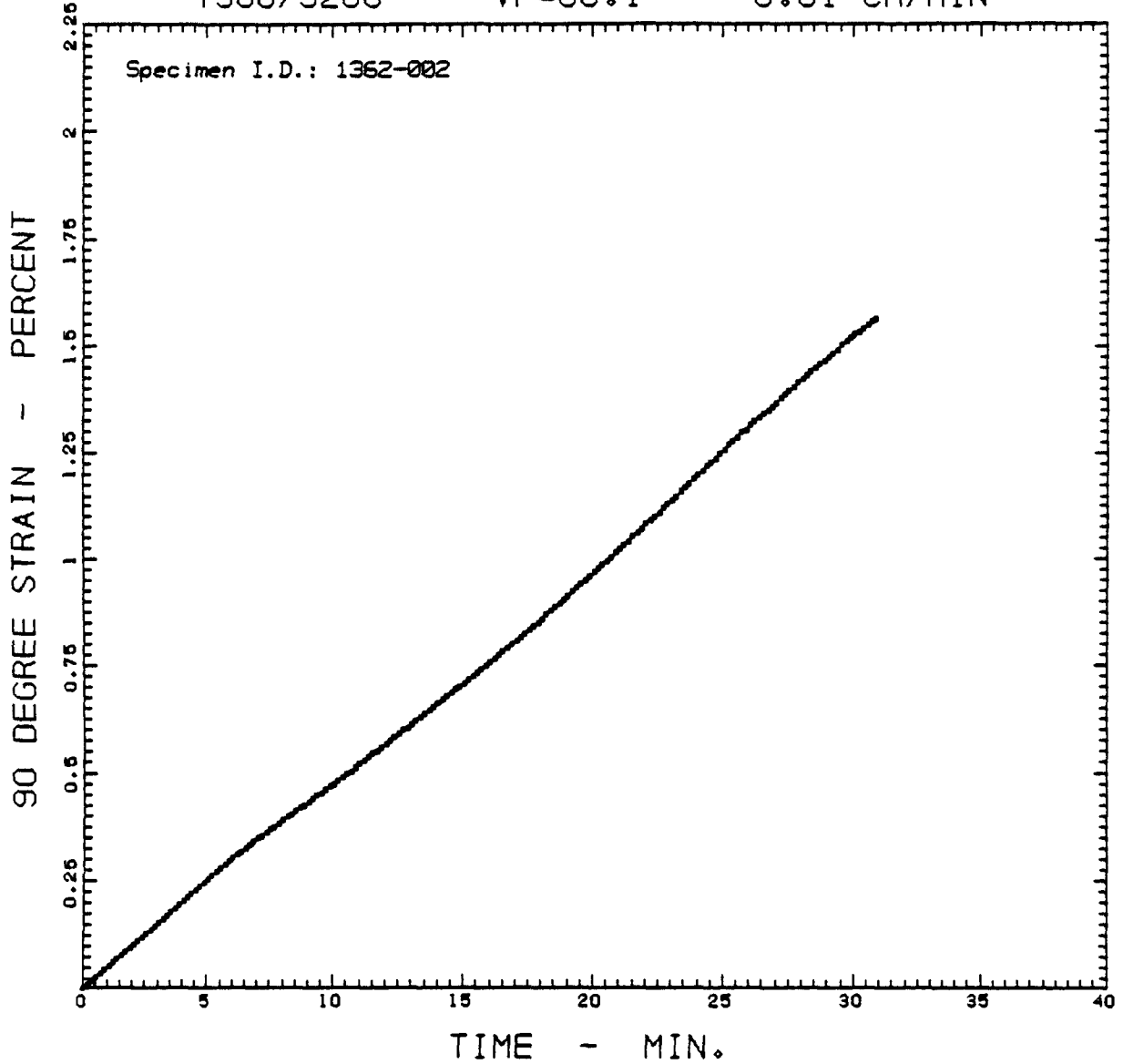

$$\text{STRAIN} = A_0 + A_1 \cdot \text{TIME} + A_2 \cdot \text{TIME}^2 + \dots + A_9 \cdot \text{TIME}^9$$

where:

$$0.0466 = \langle \text{TIME} \rangle = 30.8799$$

A0 = 0.2245E-02	A4 = 0.1630E-03	A7 = -0.1418E-07
A1 = 0.4367E-01	A5 = -0.1175E-04	A8 = 0.2131E-09
A2 = 0.4875E-02	A6 = 0.5236E-06	A9 = -0.1361E-11
A3 = -0.1308E-02		

Multiple Correlation Coefficient = 0.999995; No. of Data Points = 186

T300/5208 - VF=60.1 - 0.01 CM/MIN

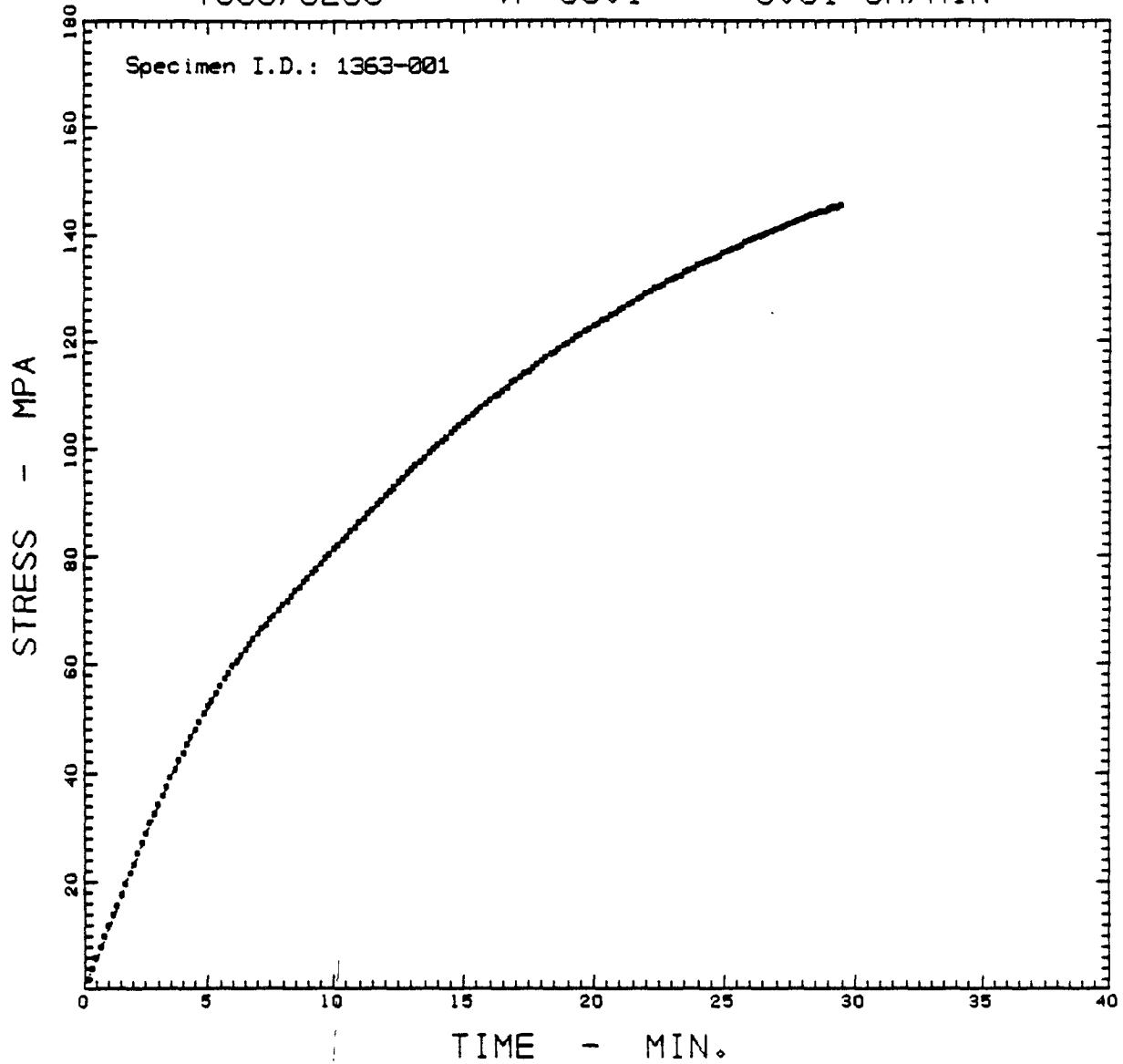

$$\text{STRESS} = A_0 + A_1 \cdot \text{TIME} + A_2 \cdot \text{TIME}^2 + \dots + A_9 \cdot \text{TIME}^9$$

where:

$$0.1393 \leq \text{TIME} \leq 29.4727$$

A0 = 0.7324E+00	A4 = 0.8730E-01	A7 = -0.8654E-05
A1 = 0.1011E+02	A5 = -0.6801E-02	A8 = 0.1307E-06
A2 = 0.1618E+01	A6 = 0.3149E-03	A9 = -0.8376E-09
A3 = -0.6154E+00		

Multiple Correlation Coefficient = 0.999990; No. of Data Points = 177

T300/5208 - VF=60.1 - 0.01 CM/MIN

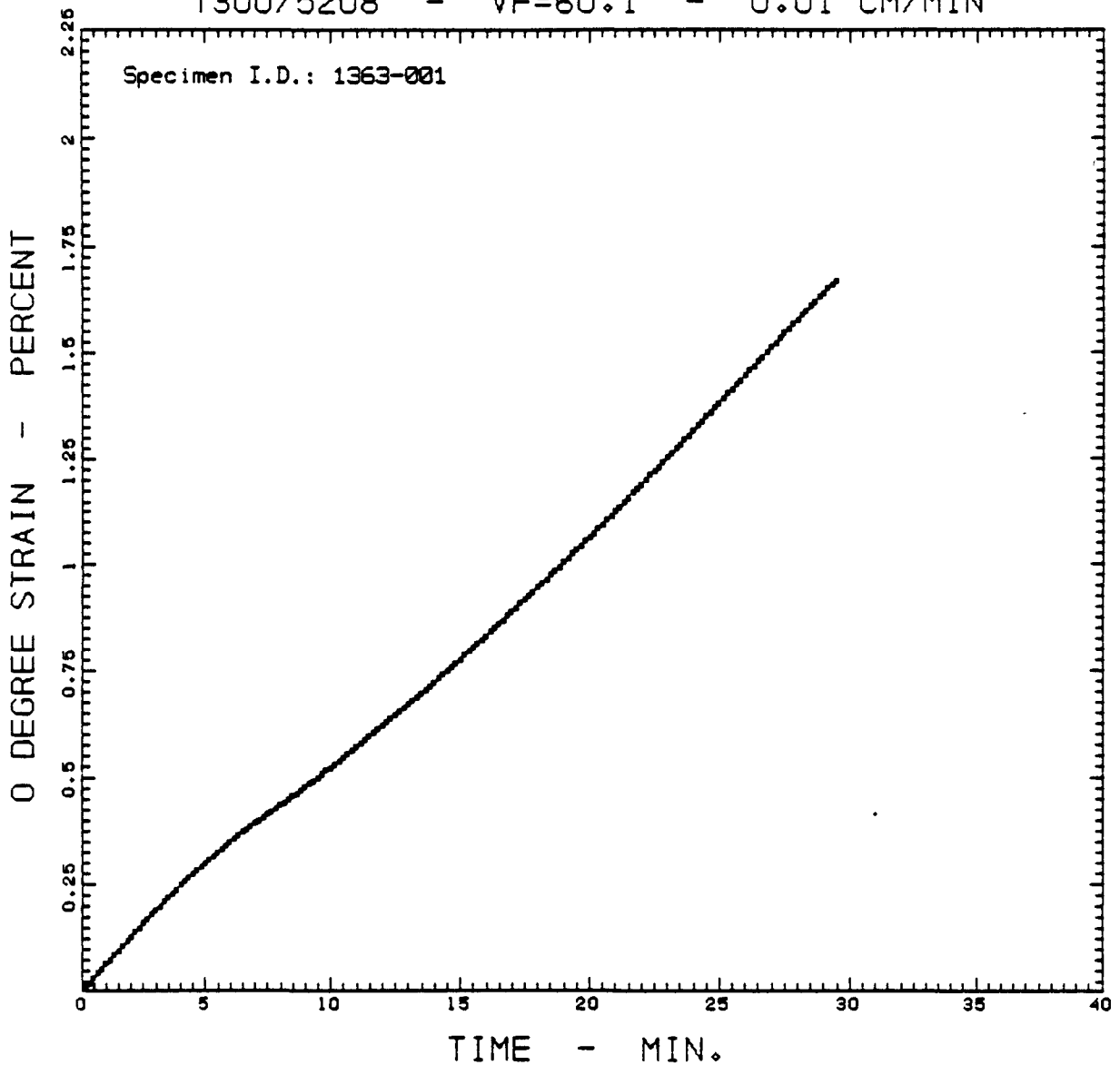

STRAIN = A0 + A1*TIME + A2*TIME^2 + ... + A9*TIME^9

where:

0.1393 = < TIME =< 29.4727

A0 = 0.3731E-02	A4 = 0.3853E-03	A7 = -0.2480E-07
A1 = 0.5380E-01	A5 = -0.2676E-04	A8 = 0.3017E-09
A2 = 0.9079E-02	A6 = 0.1074E-05	A9 = -0.1467E-11
A3 = -0.2957E-02		

Multiple Correlation Coefficient = 0.999997; No. of Data Points = 177

T300/5208 - VF=60.1 - 0.01 CM/MIN

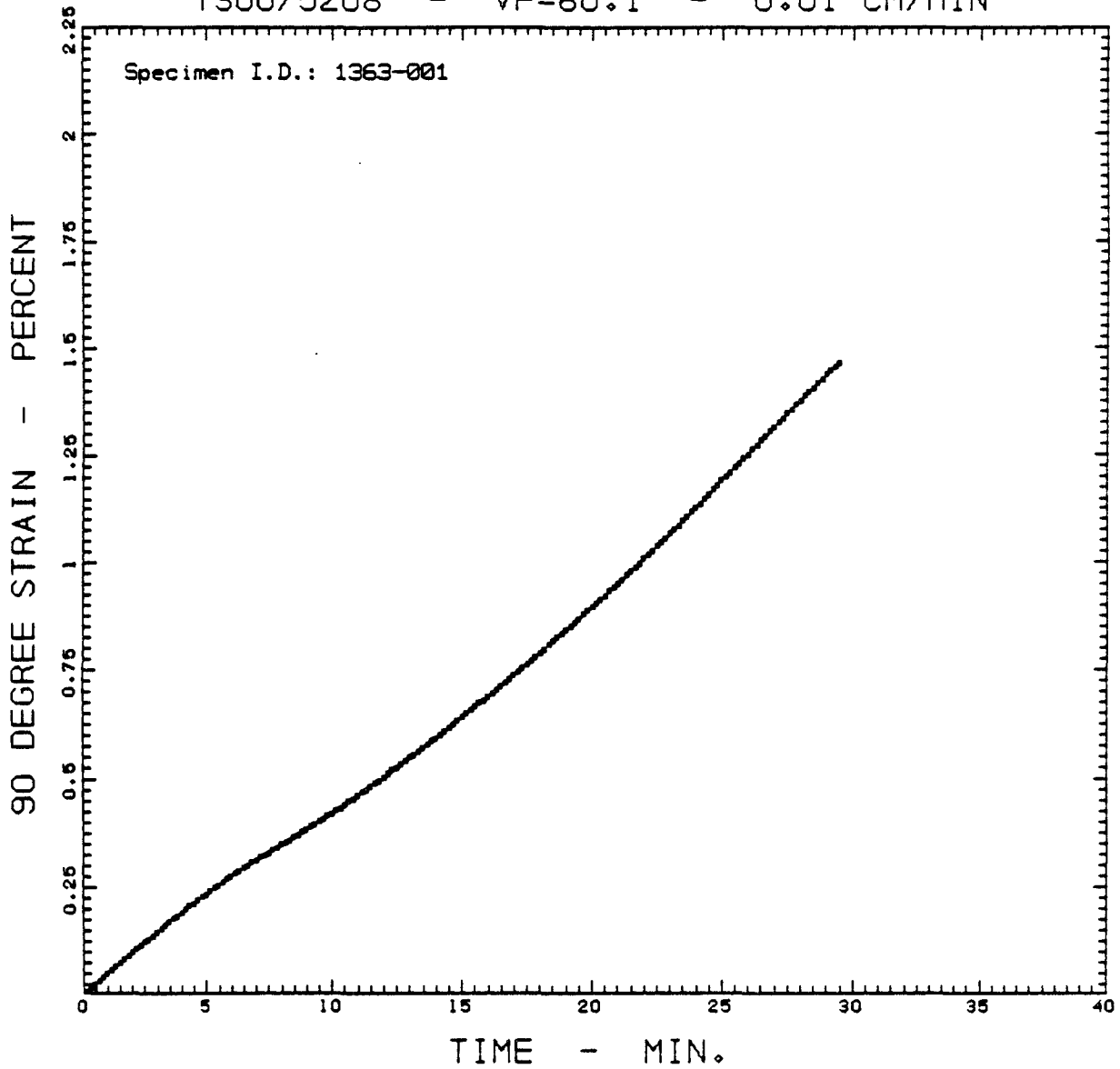

$$\text{STRAIN} = A_0 + A_1 \cdot \text{TIME} + A_2 \cdot \text{TIME}^2 + \dots + A_9 \cdot \text{TIME}^9$$

where:

$$0.1393 \leq \text{TIME} \leq 29.4727$$

A0 = 0.2973E-02	A4 = 0.2210E-03	A7 = -0.7369E-08
A1 = 0.4086E-01	A5 = -0.1356E-04	A8 = 0.3588E-10
A2 = 0.6288E-02	A6 = 0.4499E-06	A9 = 0.2412E-12
A3 = -0.1851E-02		

Multiple Correlation Coefficient = 0.999997; No. of Data Points = 177

T300/5208 - VF=60.1 - 0.01 CM/MIN

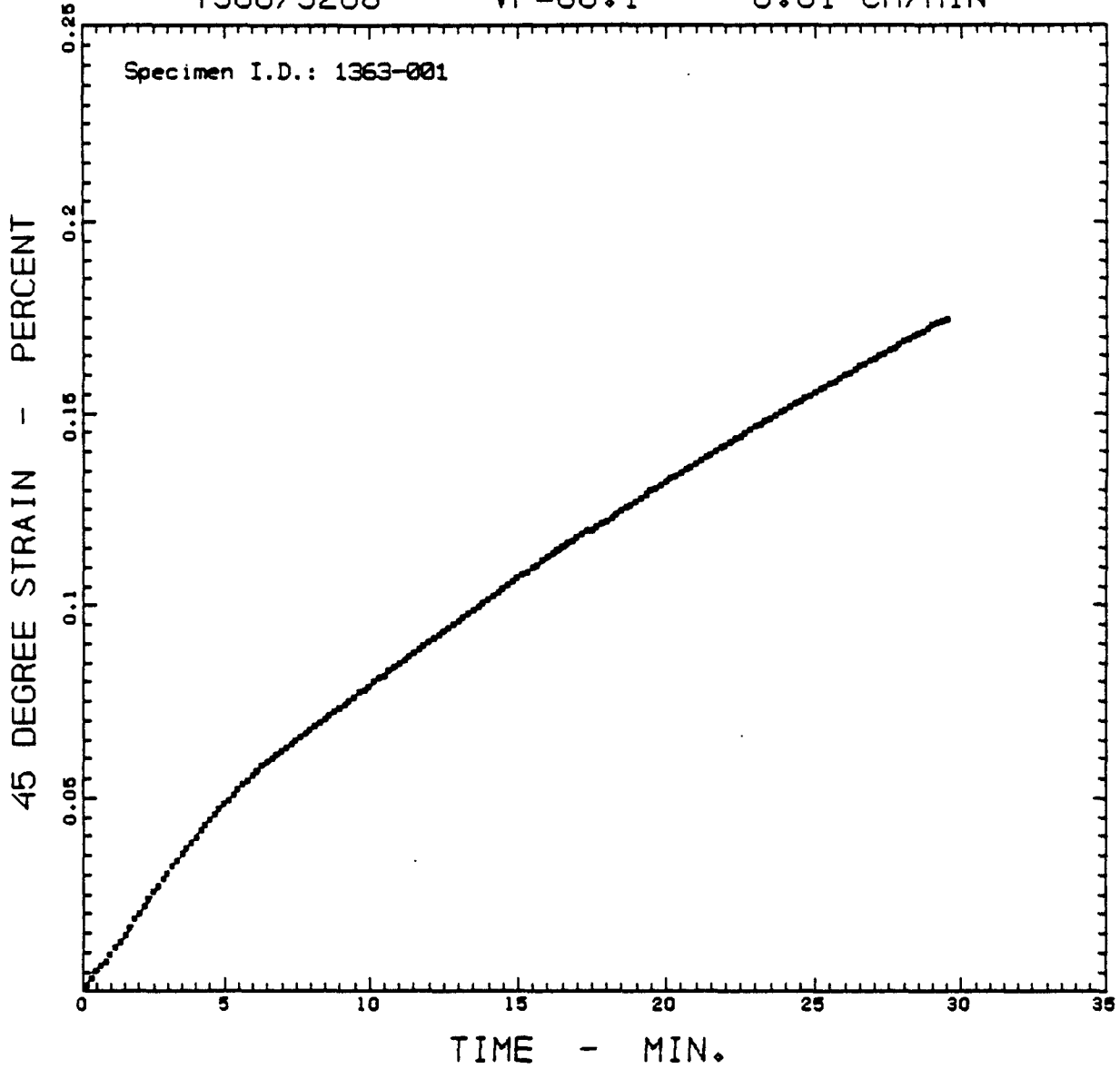

$$\text{STRAIN} = A_0 + A_1 \cdot \text{TIME} + A_2 \cdot \text{TIME}^2 + \dots + A_9 \cdot \text{TIME}^9$$

where:

$$0.1393 \leq \text{TIME} \leq 29.4727$$

A0 = 0.1233E-02	A4 = 0.1138E-03	A7 = -0.1024E-07
A1 = 0.6471E-02	A5 = -0.8538E-05	A8 = 0.1505E-09
A2 = 0.2889E-02	A6 = 0.3835E-06	A9 = -0.9375E-12
A3 = -0.8548E-03		

Multiple Correlation Coefficient = 0.999986; No. of Data Points = 177

T300/5208 - VF=60.1 - 0.01 CM/MIN

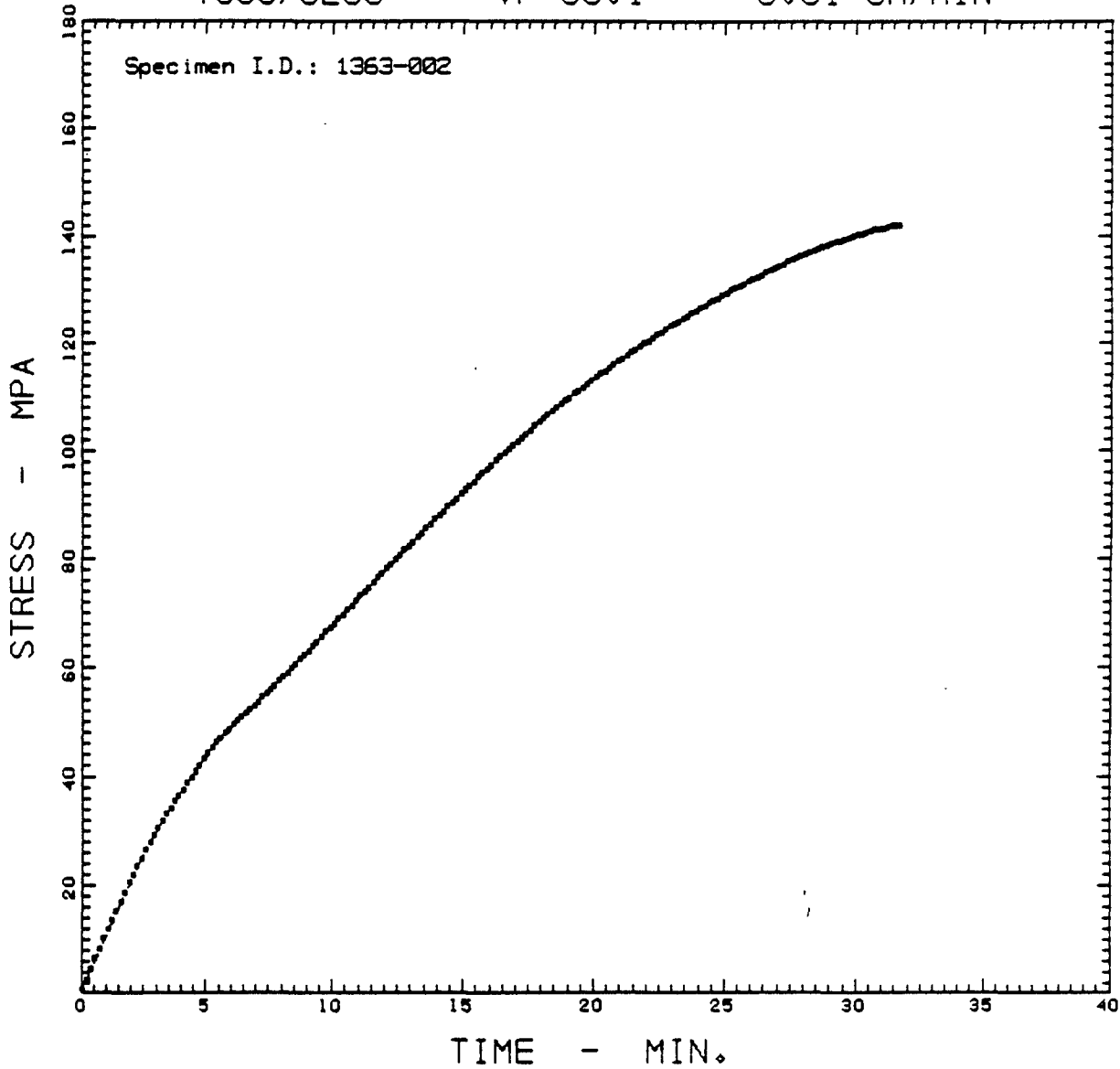

$$\text{STRESS} = A_0 + A_1 \cdot \text{TIME} + A_2 \cdot \text{TIME}^2 + \dots + A_9 \cdot \text{TIME}^9$$

where:

0.0546 < TIME < 31.7212

A0 = 0.3083E+00	A4 = 0.8036E-01	A7 = -0.9657E-05
A1 = 0.1059E+02	A5 = -0.6872E-02	A8 = 0.1501E-06
A2 = 0.6644E+00	A6 = 0.3374E-03	A9 = -0.9813E-09
A3 = -0.4761E+00		

Multiple Correlation Coefficient = 0.999989; No. of Data Points = 191

T300/5208 - VF=60.1 - 0.01 CM/MIN

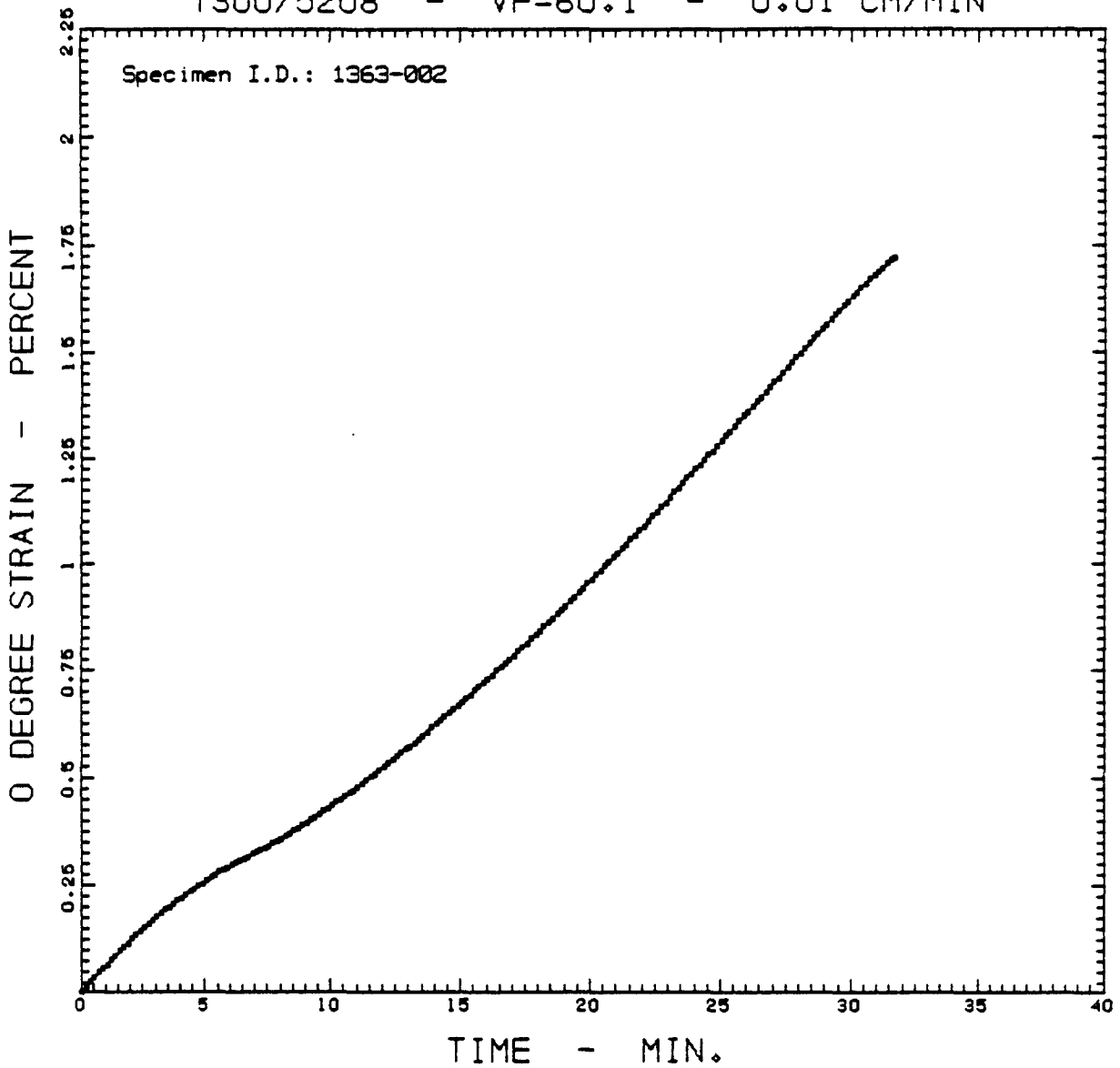

$$\text{STRAIN} = A_0 + A_1 \cdot \text{TIME} + A_2 \cdot \text{TIME}^2 + \dots + A_9 \cdot \text{TIME}^9$$

where:

$$0.0546 \leq \text{TIME} \leq 31.7212$$

- | | | |
|------------------|------------------|------------------|
| A0 = 0.2011E-02 | A4 = 0.5089E-03 | A7 = -0.5726E-07 |
| A1 = 0.5758E-01 | A5 = -0.4221E-04 | A8 = 0.8832E-09 |
| A2 = 0.5908E-02 | A6 = 0.2029E-05 | A9 = -0.5761E-11 |
| A3 = -0.3141E-02 | | |

Multiple Correlation Coefficient = 0.999997; No. of Data Points = 191

T300/5208 - VF=60.1 - 0.01 CM/MIN

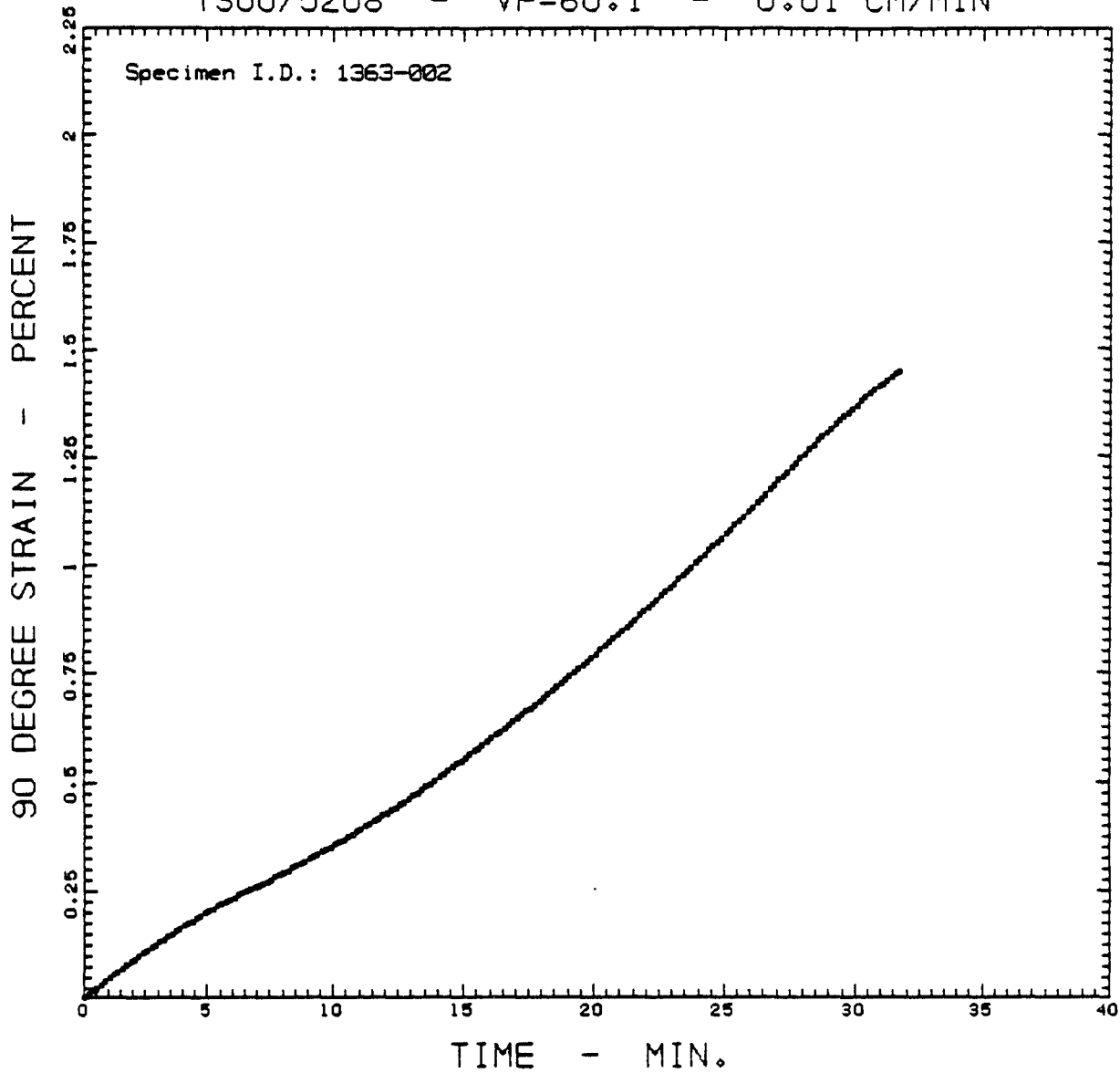

STRAIN = A0 + A1*TIME + A2*TIME^2 + ... + A9*TIME^9

where:

0.0546 < TIME < 31.7212

A0 = 0.1111E-02

A1 = 0.4057E-01

A2 = 0.4320E-02

A3 = -0.1845E-02

A4 = 0.2757E-03

A5 = -0.2149E-04

A6 = 0.9812E-06

A7 = -0.2654E-07

A8 = 0.3962E-09

A9 = -0.2532E-11

Multiple Correlation Coefficient = 0.999998; No. of Data Points = 191

T300/5208 - VF=60.1 - 0.01 CM/MIN

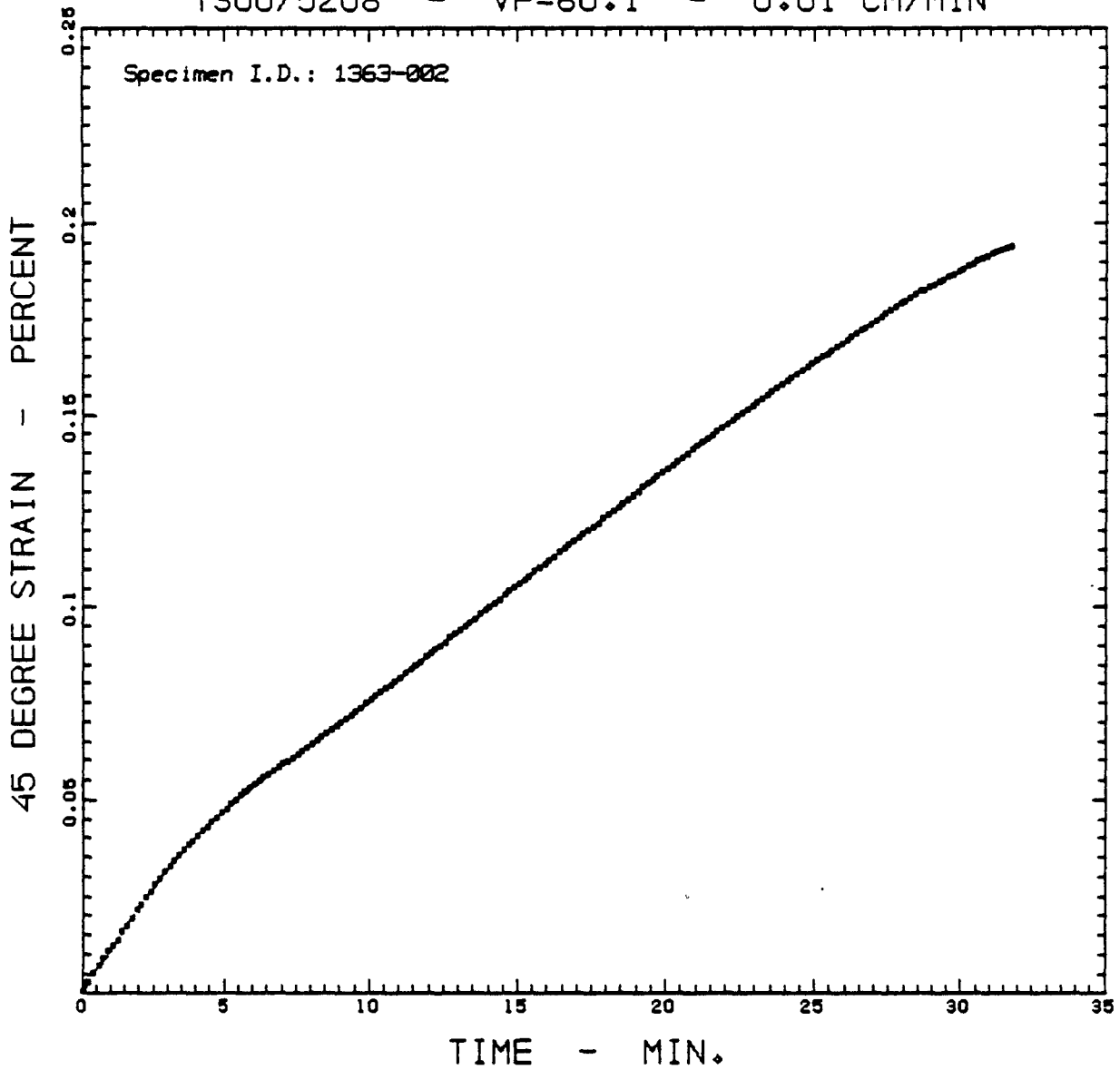

$$\text{STRAIN} = A_0 + A_1 \cdot \text{TIME} + A_2 \cdot \text{TIME}^2 + \dots + A_9 \cdot \text{TIME}^9$$

where:

$$0.0546 \leq \text{TIME} \leq 31.7212$$

A0 = 0.8477E-03	A4 = 0.9600E-04	A7 = -0.1051E-07
A1 = 0.1002E-01	A5 = -0.7885E-05	A8 = 0.1598E-09
A2 = 0.1306E-02	A6 = 0.3763E-06	A9 = -0.1022E-11
A3 = -0.6139E-03		

Multiple Correlation Coefficient = 0.999990; No. of Data Points = 191

T300/5208 - VF=61.8 - 1 CM/MIN

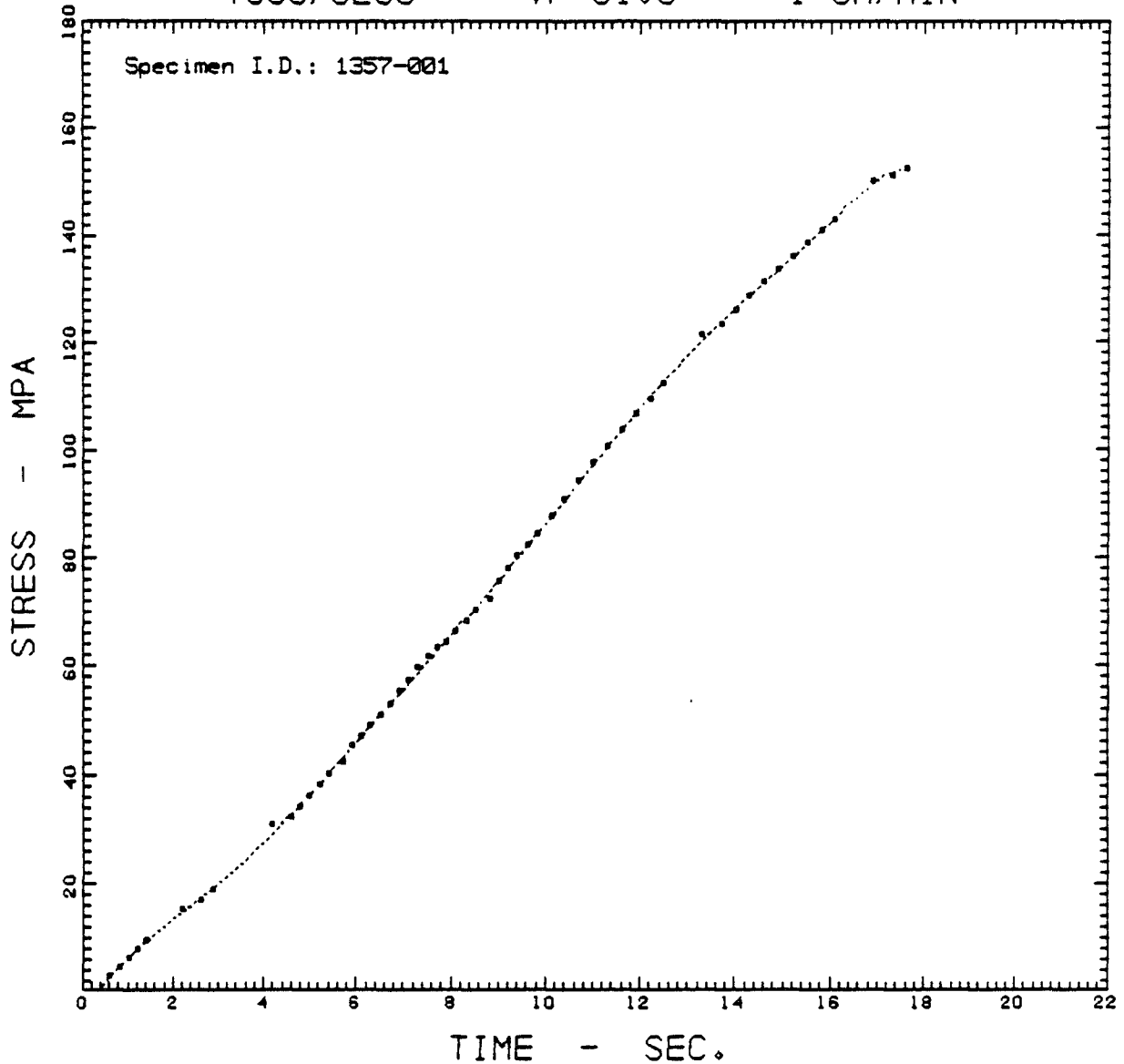

$$\text{STRESS} = A_0 + A_1 \cdot \text{TIME} + A_2 \cdot \text{TIME}^2 + \dots + A_9 \cdot \text{TIME}^9$$

where:

$$0.6052 \leq \text{TIME} \leq 17.6052$$

A0 = -0.4779E+01	A4 = 0.2396E-01	A7 = -0.3705E-03
A1 = 0.1474E+02	A5 = -0.3307E-01	A8 = 0.1323E-04
A2 = -0.4546E+01	A6 = 0.5127E-02	A9 = -0.1883E-06
A3 = 0.9091E+00		

Multiple Correlation Coefficient = 0.999895; No. of Data Points = 57

T300/5208 - VF=61.8 - 1 CM/MIN

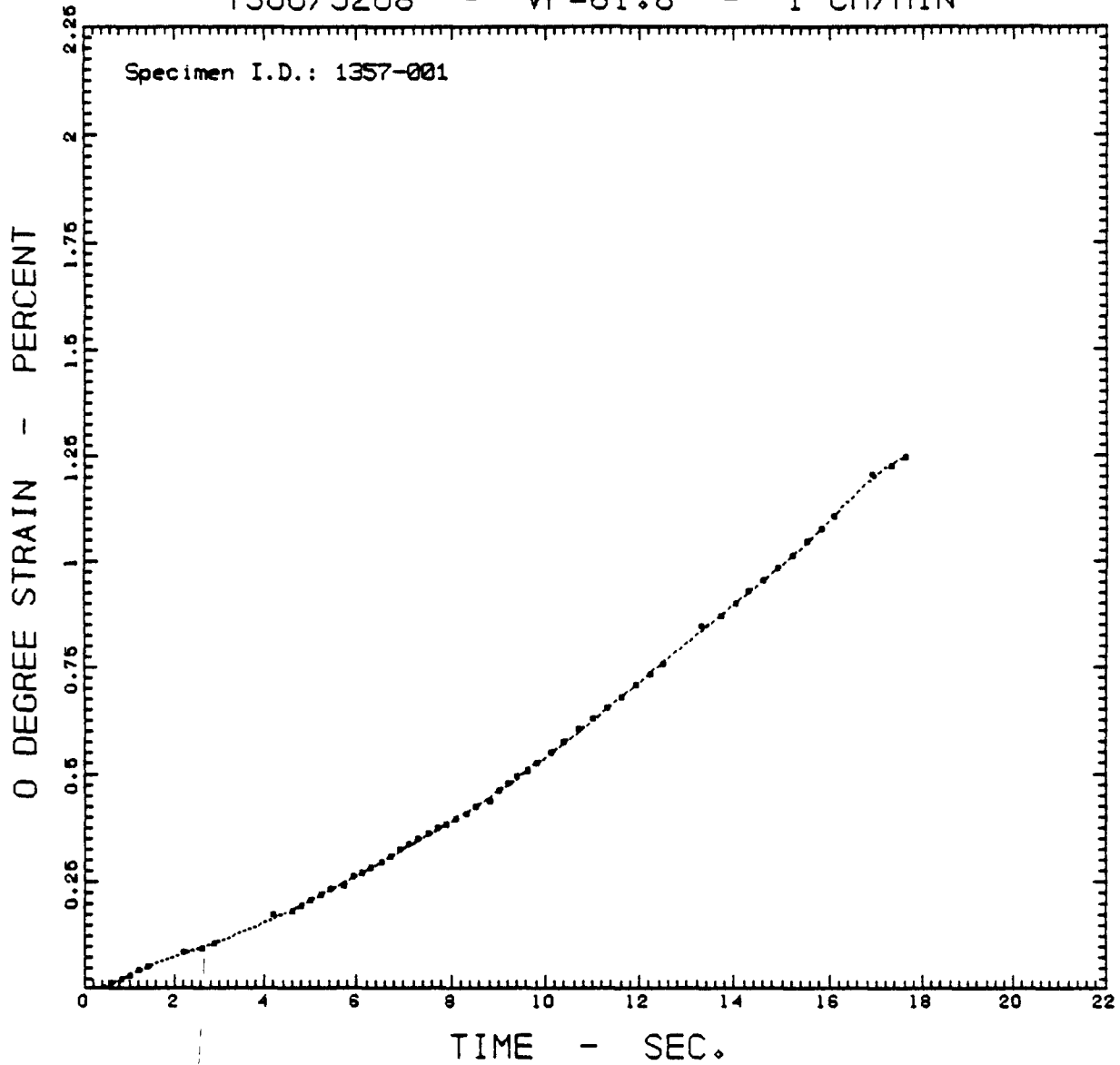

STRAIN = A0 + A1*TIME + A2*TIME^2 + ... + A9*TIME^9

where:

0.6052 < TIME < 17.6052

A0 = -0.2153E-01	A4 = 0.3808E-02	A7 = -0.5320E-05
A1 = 0.5867E-01	A5 = -0.7737E-03	A8 = 0.1747E-06
A2 = 0.1143E-02	A6 = 0.8557E-04	A9 = -0.2358E-08

Multiple Correlation Coefficient = 0.999911; No. of Data Points = 57

T300/5208 - VF=61.8 - 1 CM/MIN

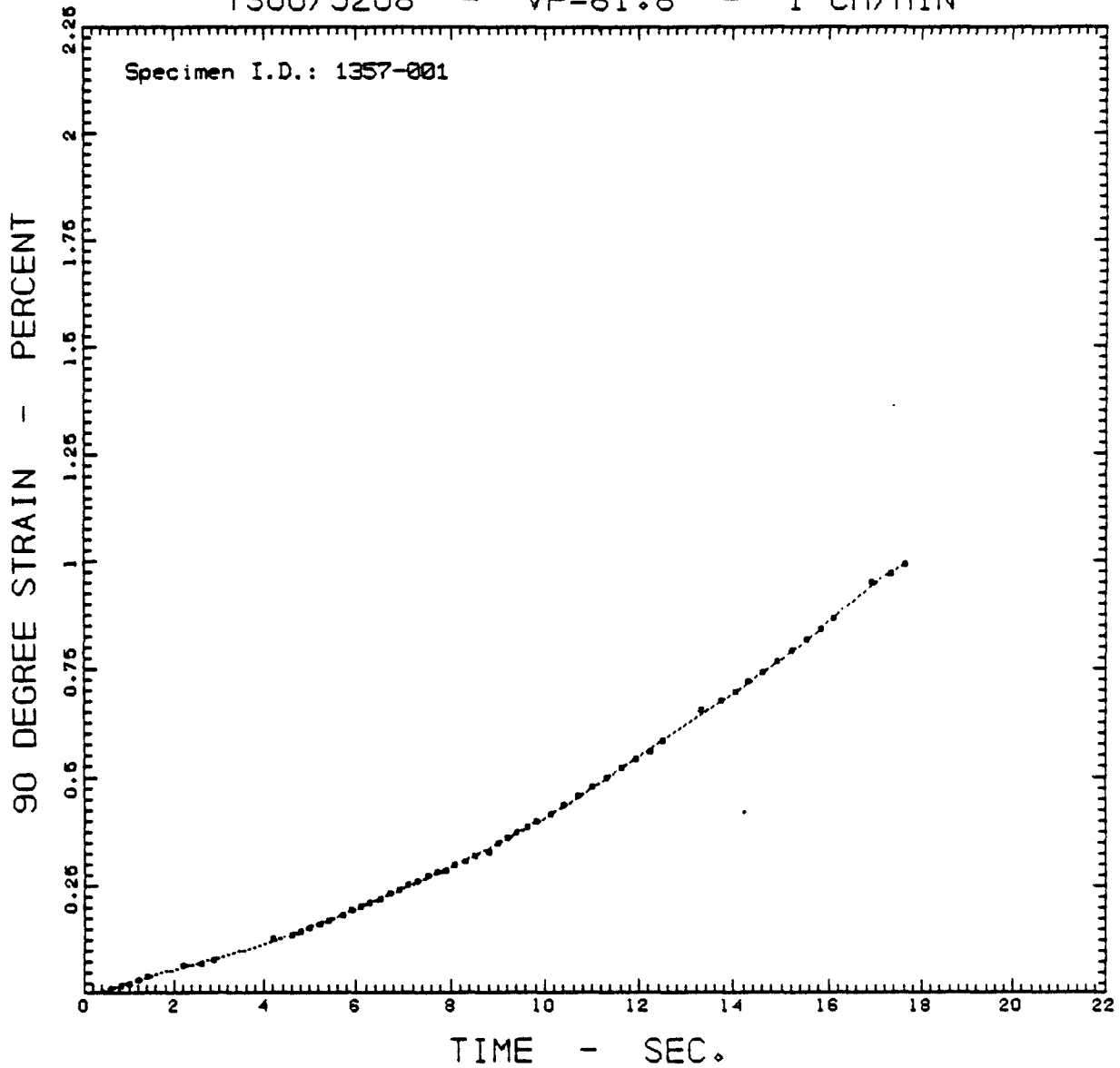

$$\text{STRAIN} = A_0 + A_1 \cdot \text{TIME} + A_2 \cdot \text{TIME}^2 + \dots + A_9 \cdot \text{TIME}^9$$

where:

$$0.6052 \leq \text{TIME} \leq 17.6052$$

$$A_0 = -0.1240E-01$$

$$A_1 = 0.3403E-01$$

$$A_2 = 0.9656E-02$$

$$A_3 = -0.1022E-01$$

$$A_4 = 0.3861E-02$$

$$A_5 = -0.7310E-03$$

$$A_6 = 0.7791E-04$$

$$A_7 = -0.4734E-05$$

$$A_8 = 0.1531E-06$$

$$A_9 = -0.2044E-08$$

Multiple Correlation Coefficient = 0.999915; No. of Data Points = 57

T300/5208 - VF=61.8 - 1 CM/MIN

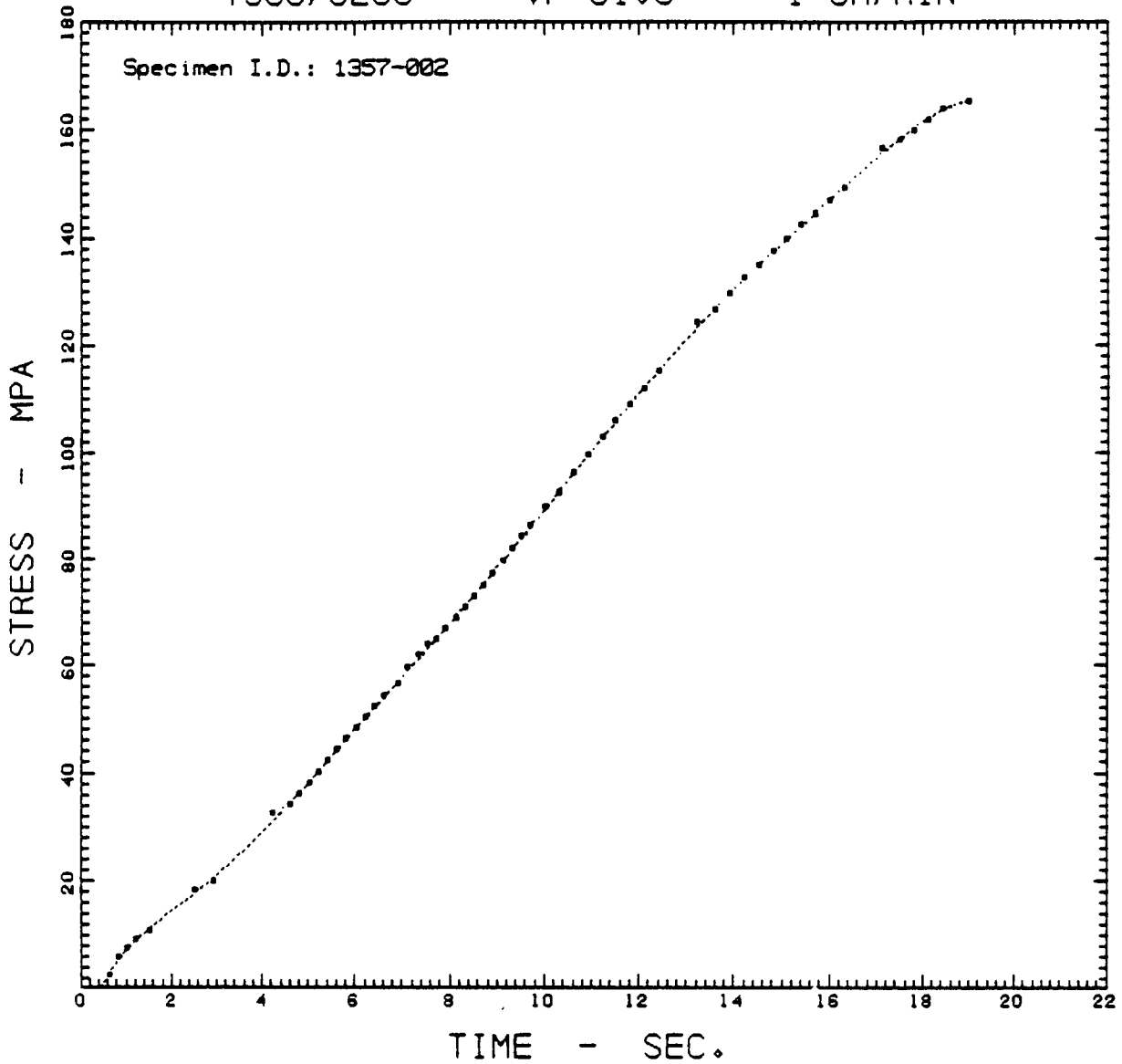

$$\text{STRESS} = A_0 + A_1 \cdot \text{TIME} + A_2 \cdot \text{TIME}^2 + \dots + A_9 \cdot \text{TIME}^9$$

where:

$$0.6130 \leq \text{TIME} \leq 19.0130$$

A0 = -0.9191E+01	A4 = -0.1031E+01	A7 = 0.3544E-03
A1 = 0.2687E+02	A5 = 0.1196E+00	A8 = -0.8059E-05
A2 = -0.1482E+02	A6 = -0.8459E-02	A9 = 0.7623E-07
A3 = 0.5291E+01		

Multiple Correlation Coefficient = 0.999929; No. of Data Points = 60

T300/5208 - VF=61.8 - 1 CM/MIN

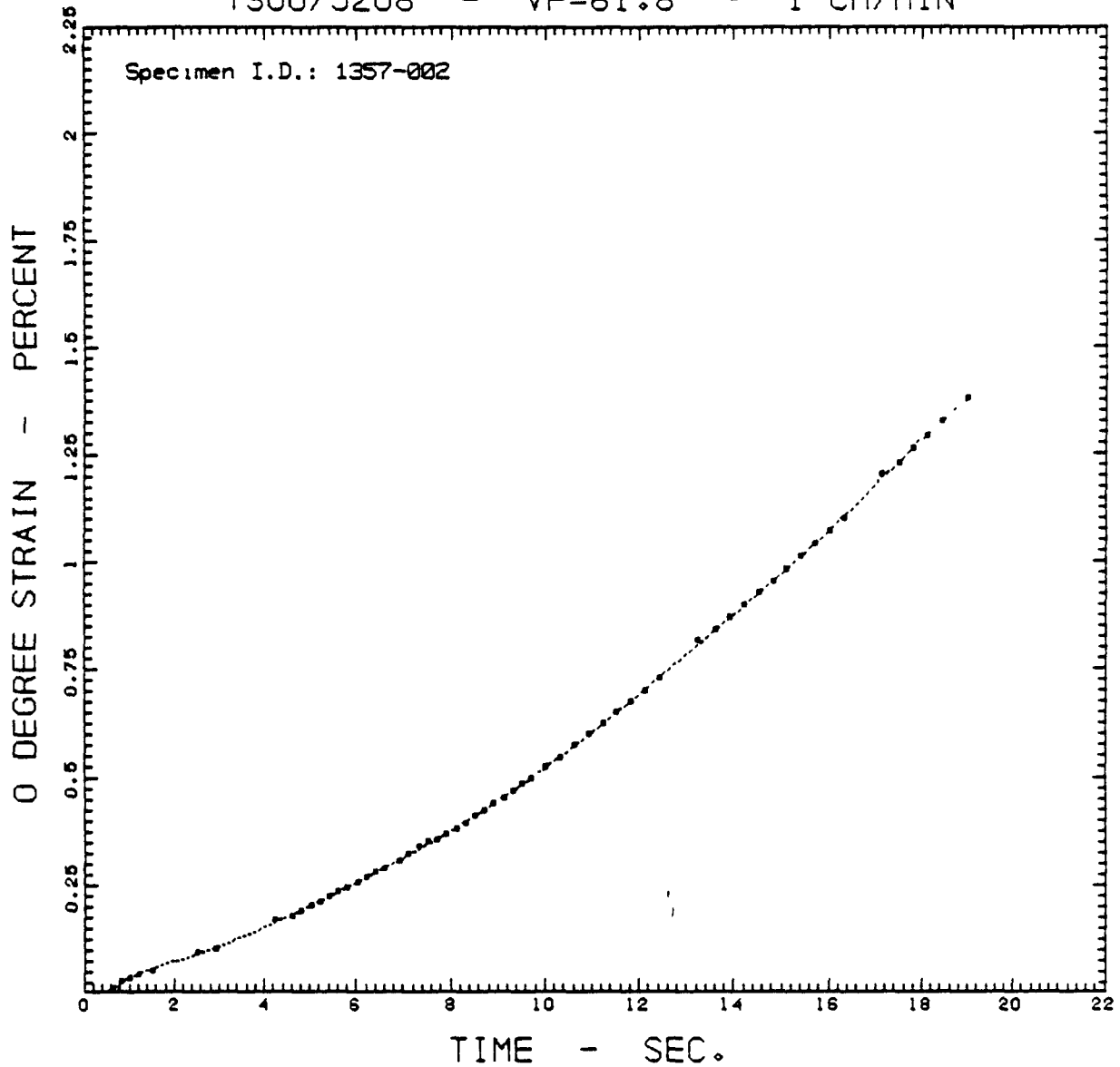

$$\text{STRAIN} = A_0 + A_1 \cdot \text{TIME} + A_2 \cdot \text{TIME}^2 + \dots + A_9 \cdot \text{TIME}^9$$

where:

$$0.6130 \leq \text{TIME} \leq 19.0130$$

A0 = -0.5338E-01	A4 = -0.5794E-02	A7 = 0.2051E-05
A1 = 0.1457E+00	A5 = 0.6809E-03	A8 = -0.4705E-07
A2 = -0.8168E-01	A6 = -0.4854E-04	A9 = 0.4497E-09
A3 = 0.2943E-01		

Multiple Correlation Coefficient = 0.999934; No. of Data Points = 60

T300/5208 - VF=61.8 - 1 CM/MIN

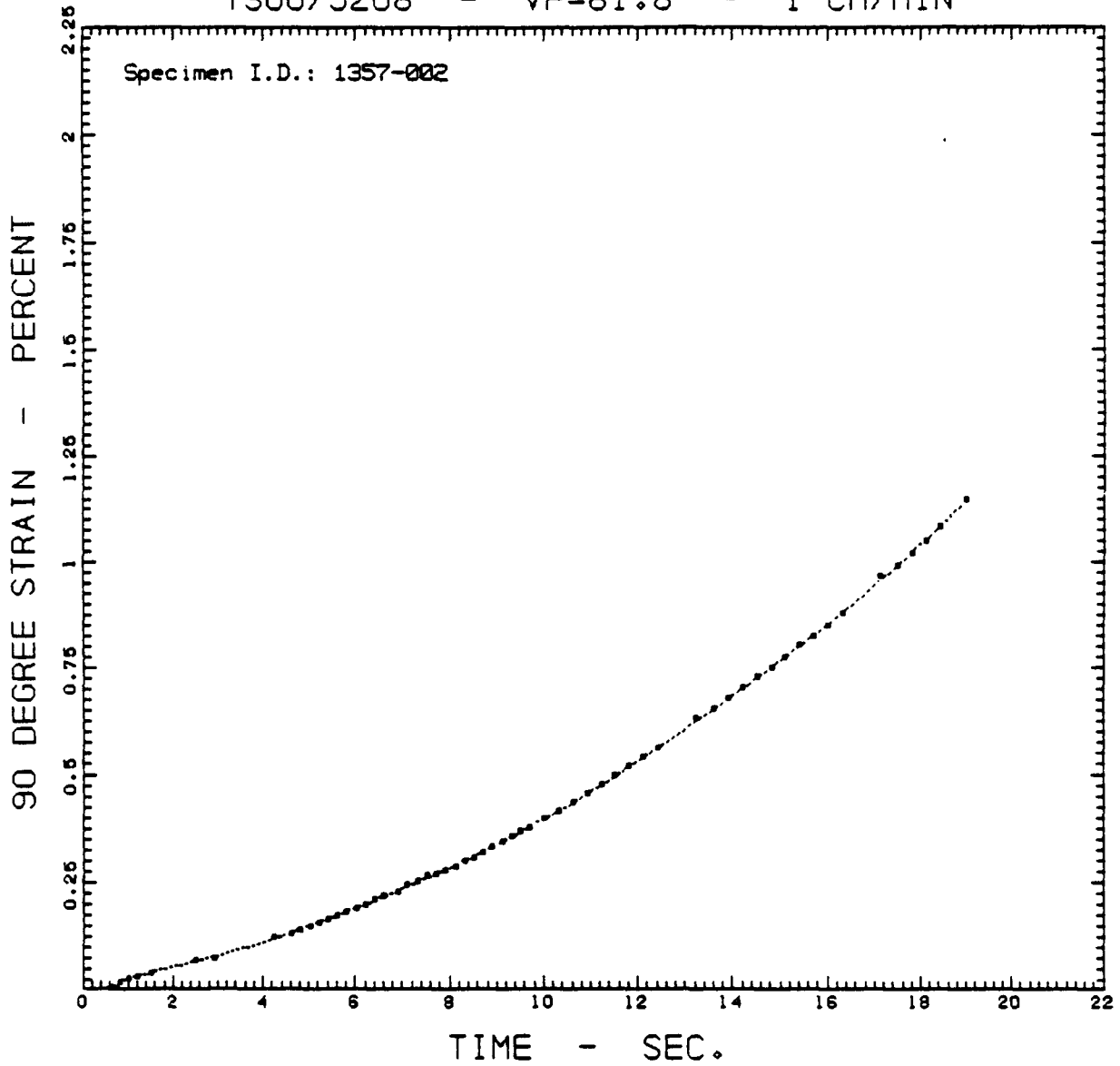

$$\text{STRAIN} = A_0 + A_1 \cdot \text{TIME} + A_2 \cdot \text{TIME}^2 + \dots + A_9 \cdot \text{TIME}^9$$

where:

$$0.6130 \leq \text{TIME} \leq 19.0130$$

A0 = -0.4037E-01	A4 = -0.4582E-02	A7 = 0.1754E-05
A1 = 0.1098E+00	A5 = 0.5491E-03	A8 = -0.4199E-07
A2 = -0.6280E-01	A6 = -0.4016E-04	A9 = 0.4242E-09
A3 = 0.2292E-01		

Multiple Correlation Coefficient = 0.999931; No. of Data Points = 60

T300/5208 - VF=61.8 - 1 CM/MIN

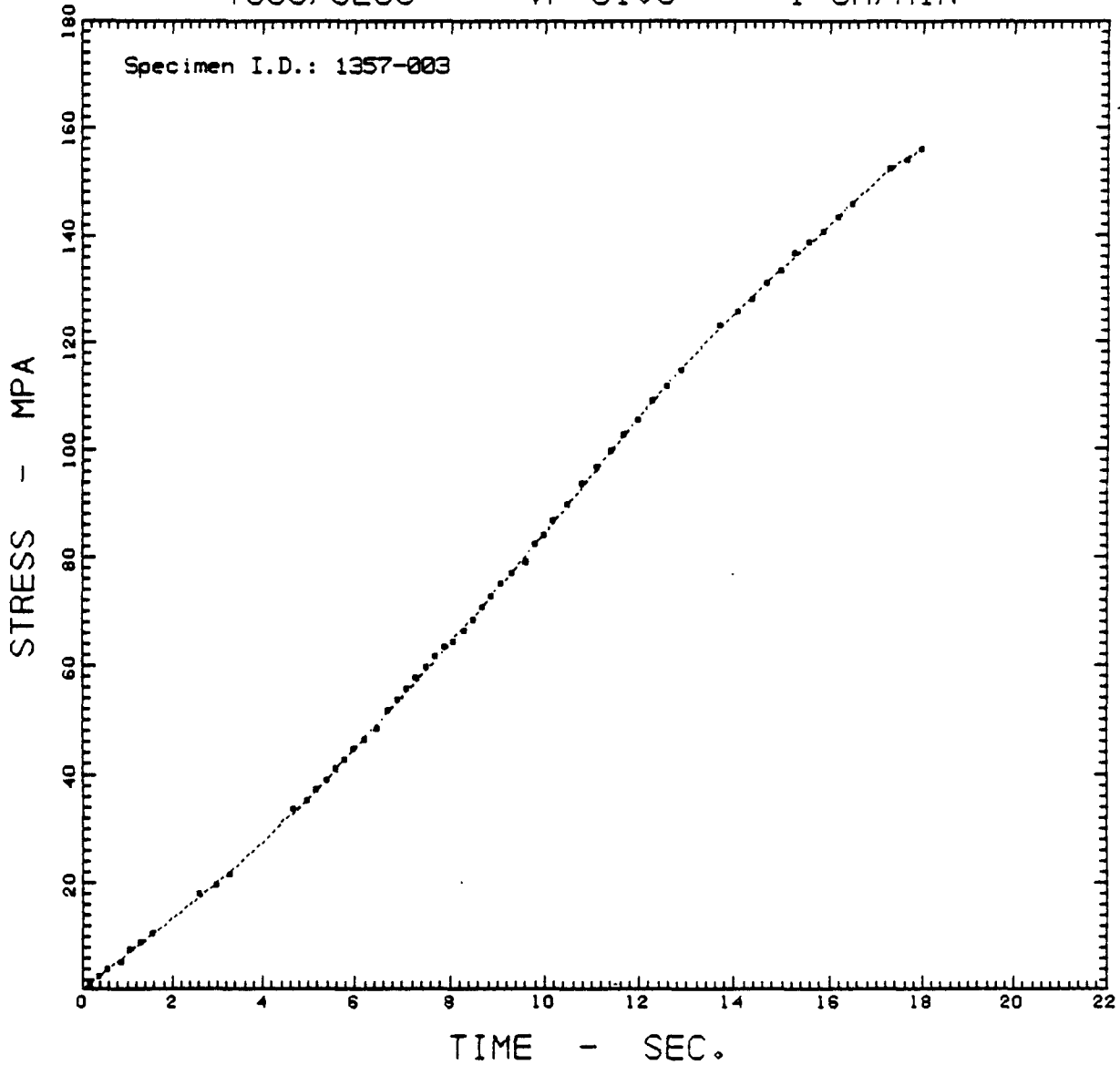

$$\text{STRESS} = A_0 + A_1 \cdot \text{TIME} + A_2 \cdot \text{TIME}^2 + \dots + A_9 \cdot \text{TIME}^9$$

where:

$$0.1652 \leq \text{TIME} \leq 17.9652$$

$$A_0 = 0.2624E+00$$

$$A_1 = 0.5986E+01$$

$$A_2 = 0.1213E+01$$

$$A_3 = -0.9138E+00$$

$$A_4 = 0.3271E+00$$

$$A_5 = -0.5987E-01$$

$$A_6 = 0.6191E-02$$

$$A_7 = -0.3660E-03$$

$$A_8 = 0.1153E-04$$

$$A_9 = -0.1500E-06$$

Multiple Correlation Coefficient = 0.999914; No. of Data Points = 59

T300/5208 - VF=61.8 - 1 CM/MIN

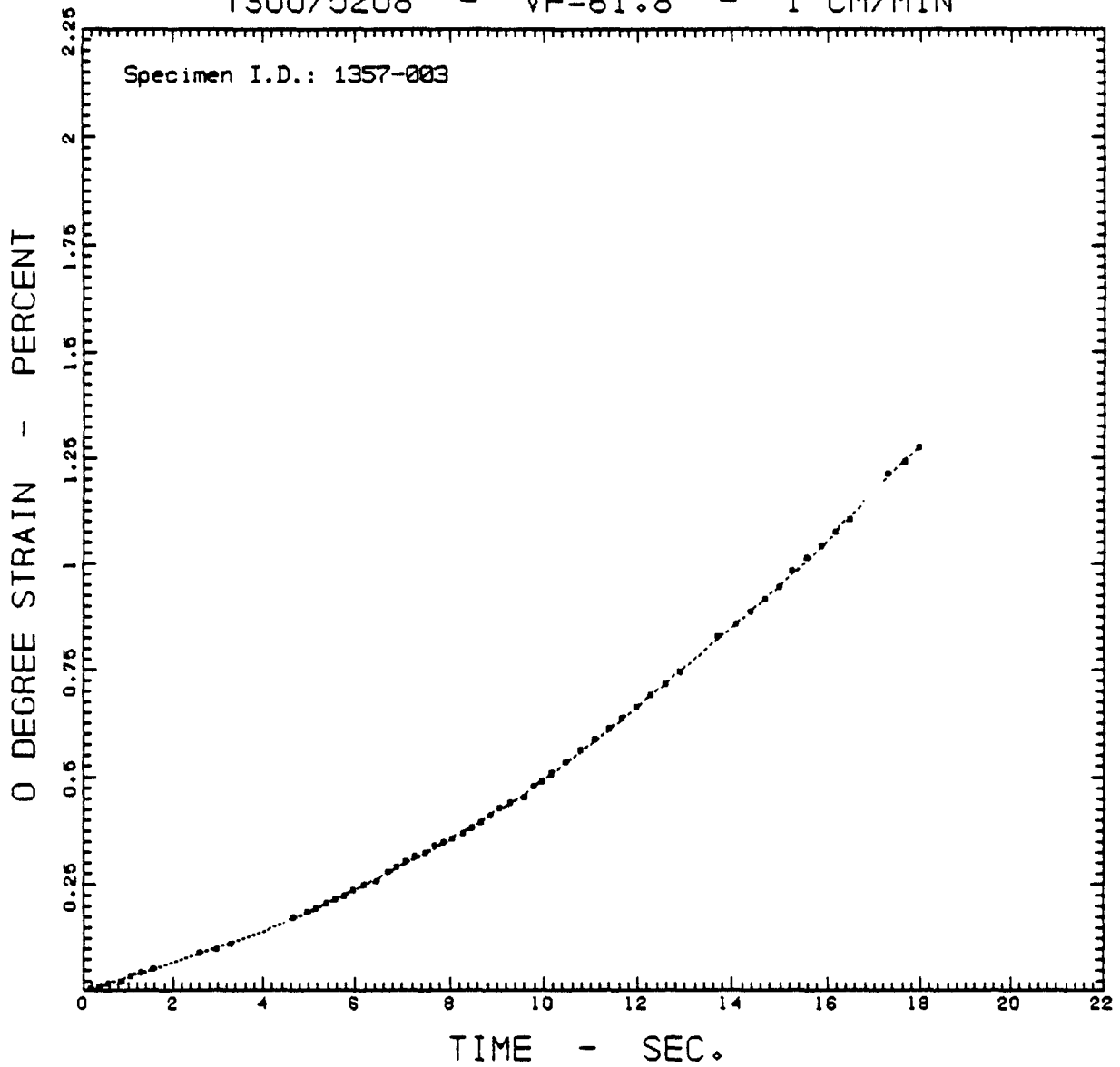

$$\text{STRAIN} = A_0 + A_1 \cdot \text{TIME} + A_2 \cdot \text{TIME}^2 + \dots + A_9 \cdot \text{TIME}^9$$

where:

$$0.1652 \leq \text{TIME} \leq 17.9652$$

A0 = 0.1662E-02	A4 = 0.4079E-02	A7 = -0.4201E-05
A1 = 0.1932E-01	A5 = -0.7100E-03	A8 = 0.1317E-06
A2 = 0.2082E-01	A6 = 0.7181E-04	A9 = -0.1710E-08
A3 = -0.1284E-01		

Multiple Correlation Coefficient = 0.999927; No. of Data Points = 59

T300/5208 - VF=61.8 - 1 CM/MIN

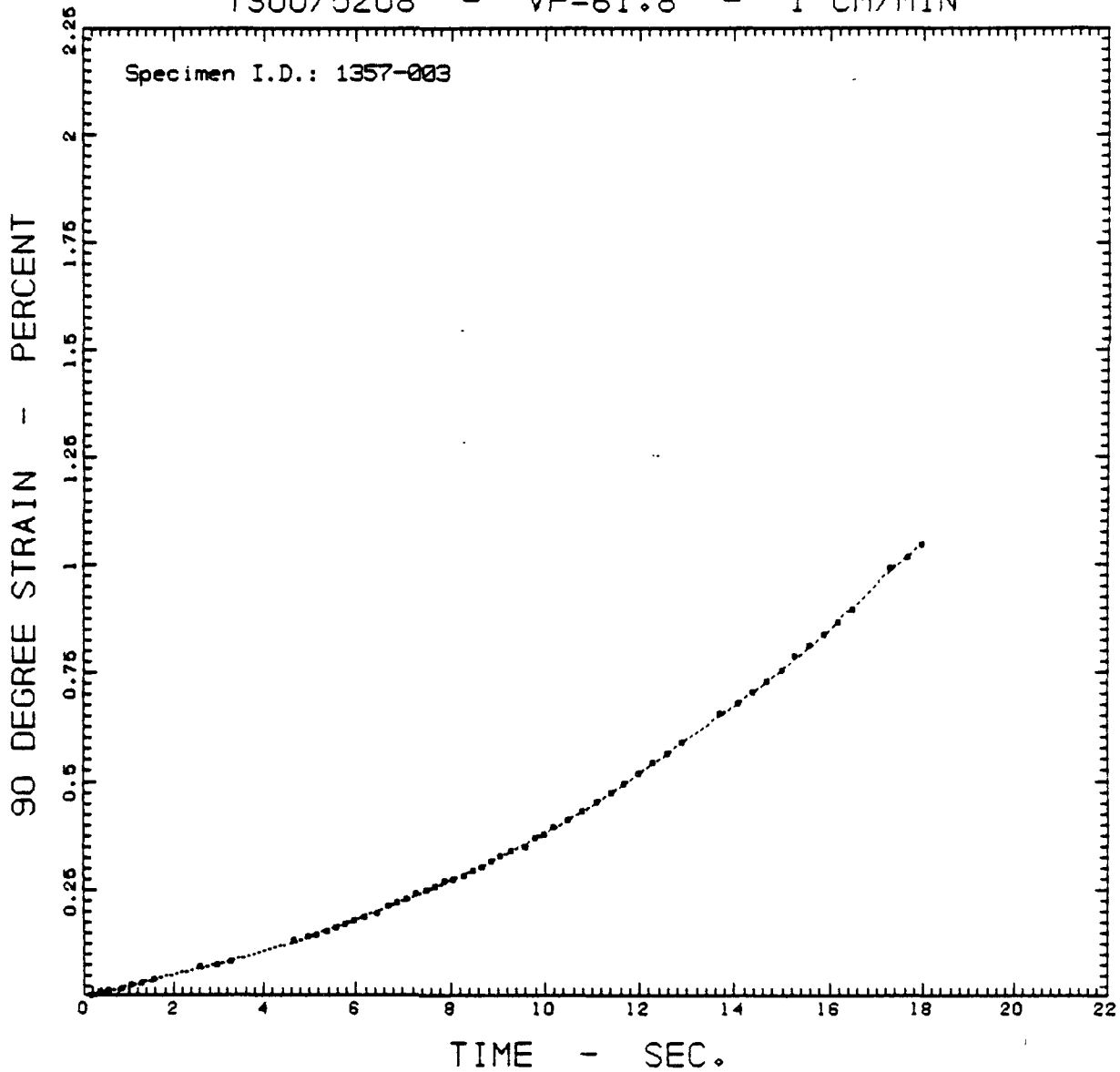

$$\text{STRAIN} = A_0 + A_1 \cdot \text{TIME} + A_2 \cdot \text{TIME}^2 + \dots + A_9 \cdot \text{TIME}^9$$

where:

$$0.1652 \leq \text{TIME} \leq 17.9652$$

A0 = 0.1846E-02	A4 = 0.3669E-02	A7 = -0.3680E-05
A1 = 0.1120E-01	A5 = -0.6310E-03	A8 = 0.1149E-06
A2 = 0.1946E-01	A6 = 0.6329E-04	A9 = -0.1488E-08
A3 = -0.1175E-01		

Multiple Correlation Coefficient = 0.999926; No. of Data Points = 59

T300/5208 - VF=61.8 - 1 CM/MIN

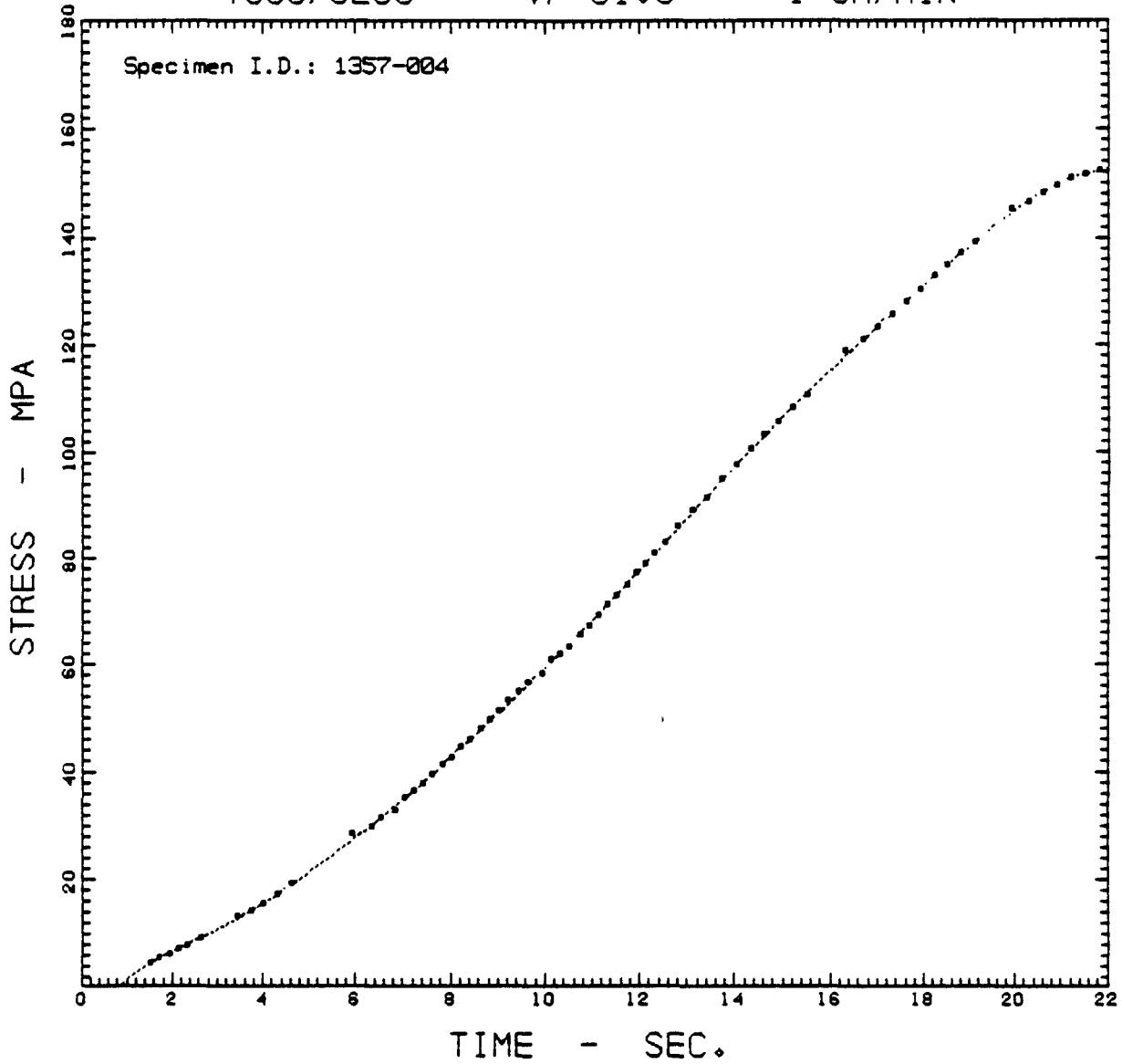

STRESS = A0 + A1*TIME + A2*TIME^2 + ... + A9*TIME^9

where:

1.5139 < TIME < 21.8139

A0 = -0.1006E+02	A4 = -0.4210E+00	A7 = 0.9505E-04
A1 = 0.1770E+02	A5 = 0.4233E-01	A8 = -0.1883E-05
A2 = -0.8316E+01	A6 = -0.2603E-02	A9 = 0.1547E-07
A3 = 0.2526E+01		

Multiple Correlation Coefficient = 0.999948; No. of Data Points = 70

T300/5208 - VF=61.8 - 1 CM/MIN

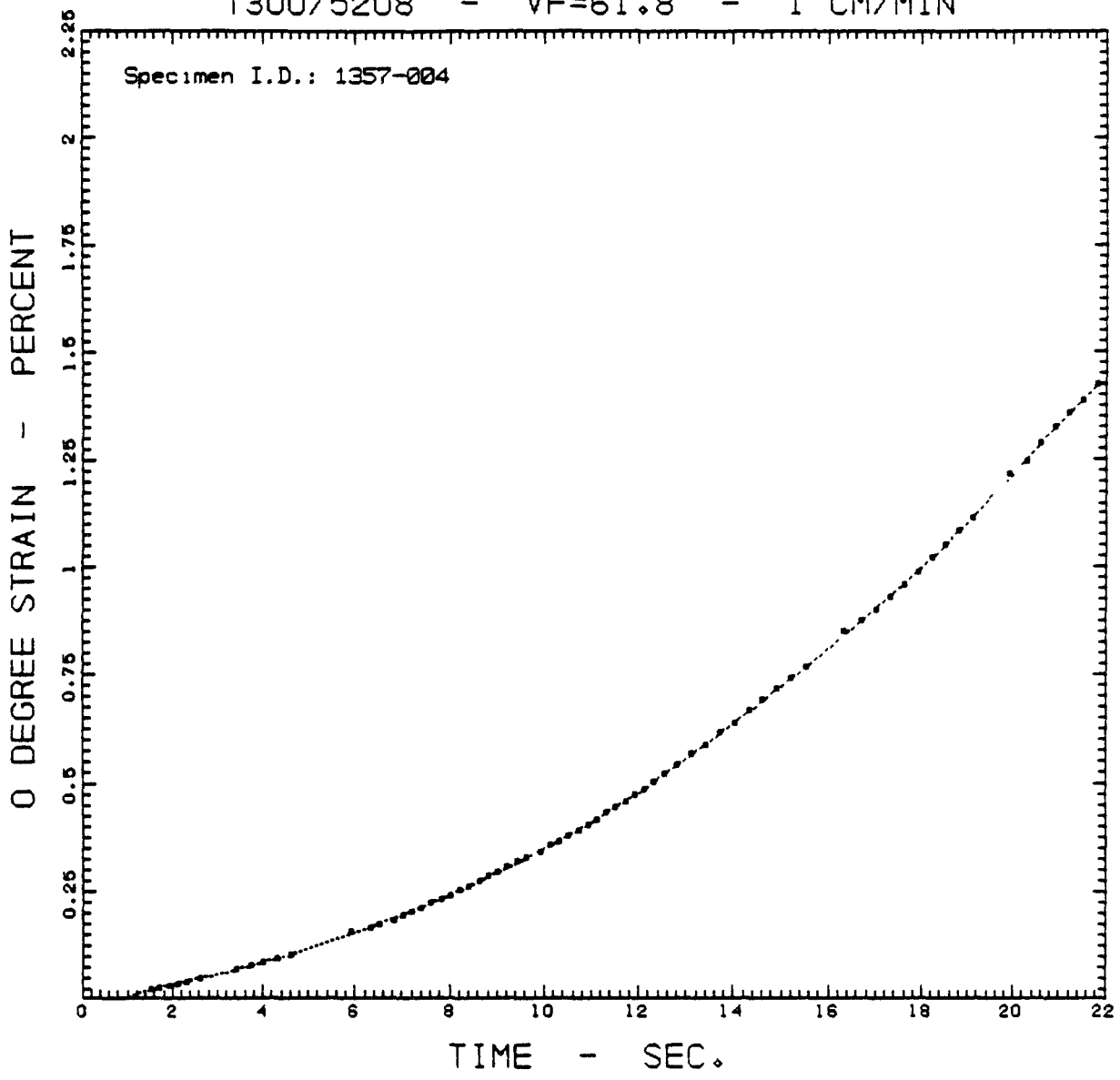

$$\text{STRAIN} = A_0 + A_1 \cdot \text{TIME} + A_2 \cdot \text{TIME}^2 + \dots + A_9 \cdot \text{TIME}^9$$

where: 1.5139 < TIME < 21.8139

A0 = -0.5653E-01	A4 = -0.1832E-02	A7 = 0.2369E-06
A1 = 0.9308E-01	A5 = 0.1642E-03	A8 = -0.2837E-08
A2 = -0.4149E-01	A6 = -0.8505E-05	A9 = 0.3575E-11
A3 = 0.1193E-01		

Multiple Correlation Coefficient = 0.999953; No. of Data Points = 70

T300/5208 - VF=61.8 - 1 CM/MIN

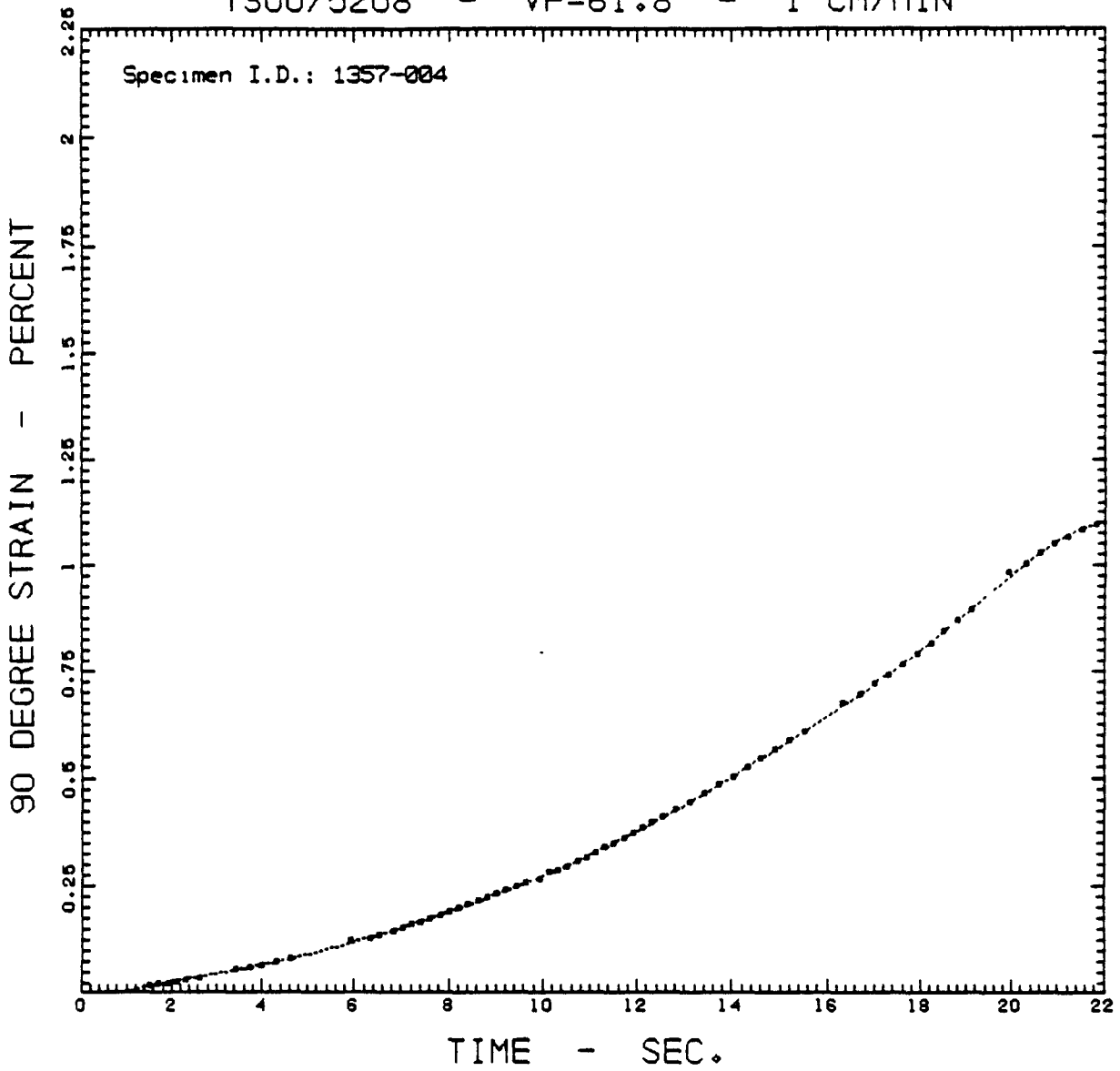

$$\text{STRAIN} = A_0 + A_1 \cdot \text{TIME} + A_2 \cdot \text{TIME}^2 + \dots + A_9 \cdot \text{TIME}^9$$

where: 1.5139 < TIME < 21.8139

- | | | |
|------------------|------------------|------------------|
| A0 = -0.5062E-01 | A4 = -0.1740E-02 | A7 = 0.2282E-06 |
| A1 = 0.8306E-01 | A5 = 0.1579E-03 | A8 = -0.2529E-08 |
| A2 = -0.3867E-01 | A6 = -0.8247E-05 | A9 = -0.2313E-11 |
| A3 = 0.1118E-01 | | |

Multiple Correlation Coefficient = 0.999946; No. of Data Points = 70

T300/5208 - VF=60.1 - 1 CM/MIN

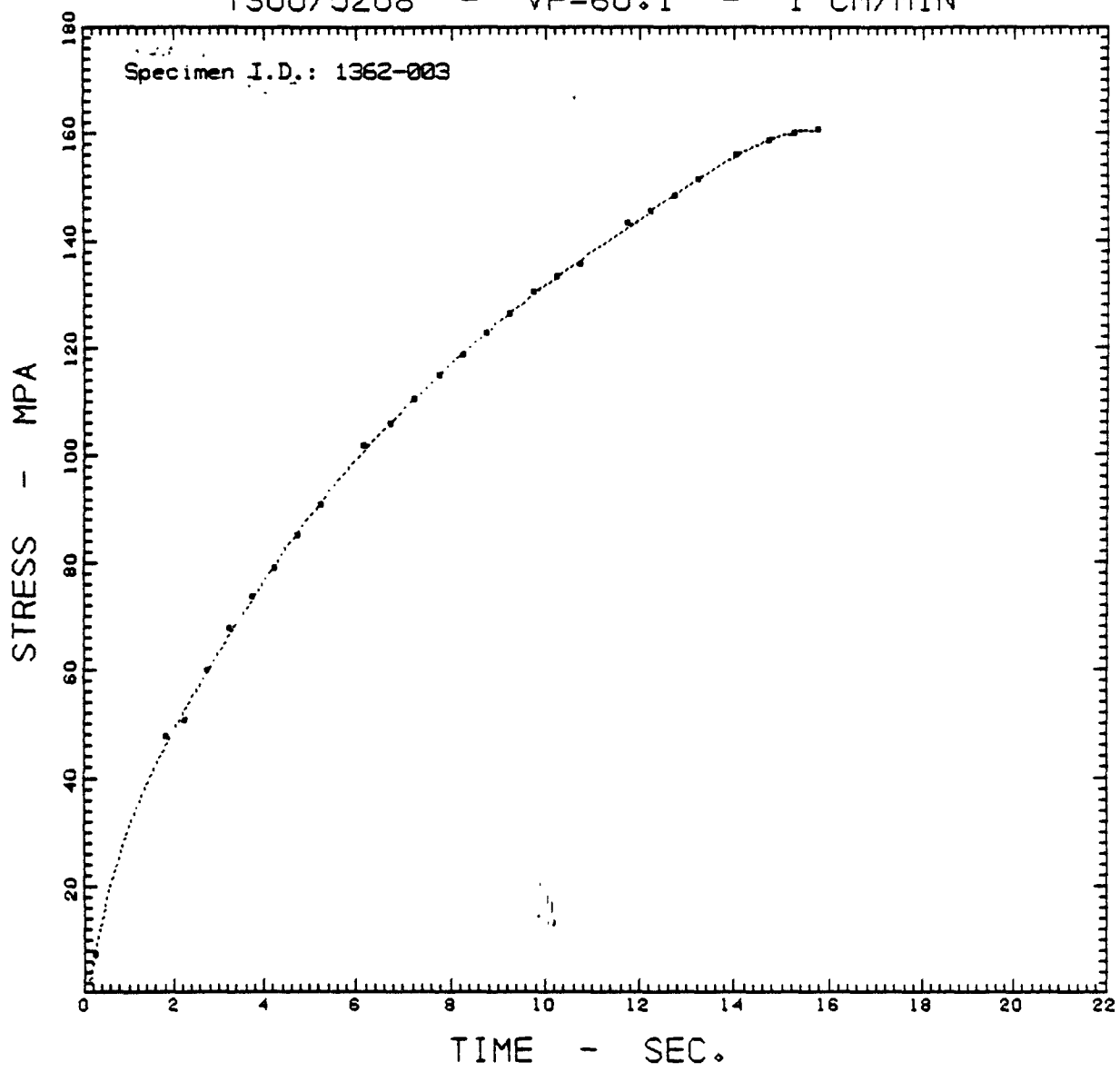

$$\text{STRESS} = A_0 + A_1 \cdot \text{TIME} + A_2 \cdot \text{TIME}^2 + \dots + A_9 \cdot \text{TIME}^9$$

where: $0.2304 \leq \text{TIME} \leq 15.7304$

- | | | |
|------------------|------------------|------------------|
| A0 = -0.4287E+01 | A4 = -0.2620E+01 | A7 = 0.1865E-02 |
| A1 = 0.5541E+02 | A5 = 0.3792E+00 | A8 = -0.5635E-04 |
| A2 = -0.2873E+02 | A6 = -0.3417E-01 | A9 = 0.7225E-06 |
| A3 = 0.1116E+02 | | |

Multiple Correlation Coefficient = 0.999765; No. of Data Points = 27

T300/5208 - VF=60.1 - 1 CM/MIN

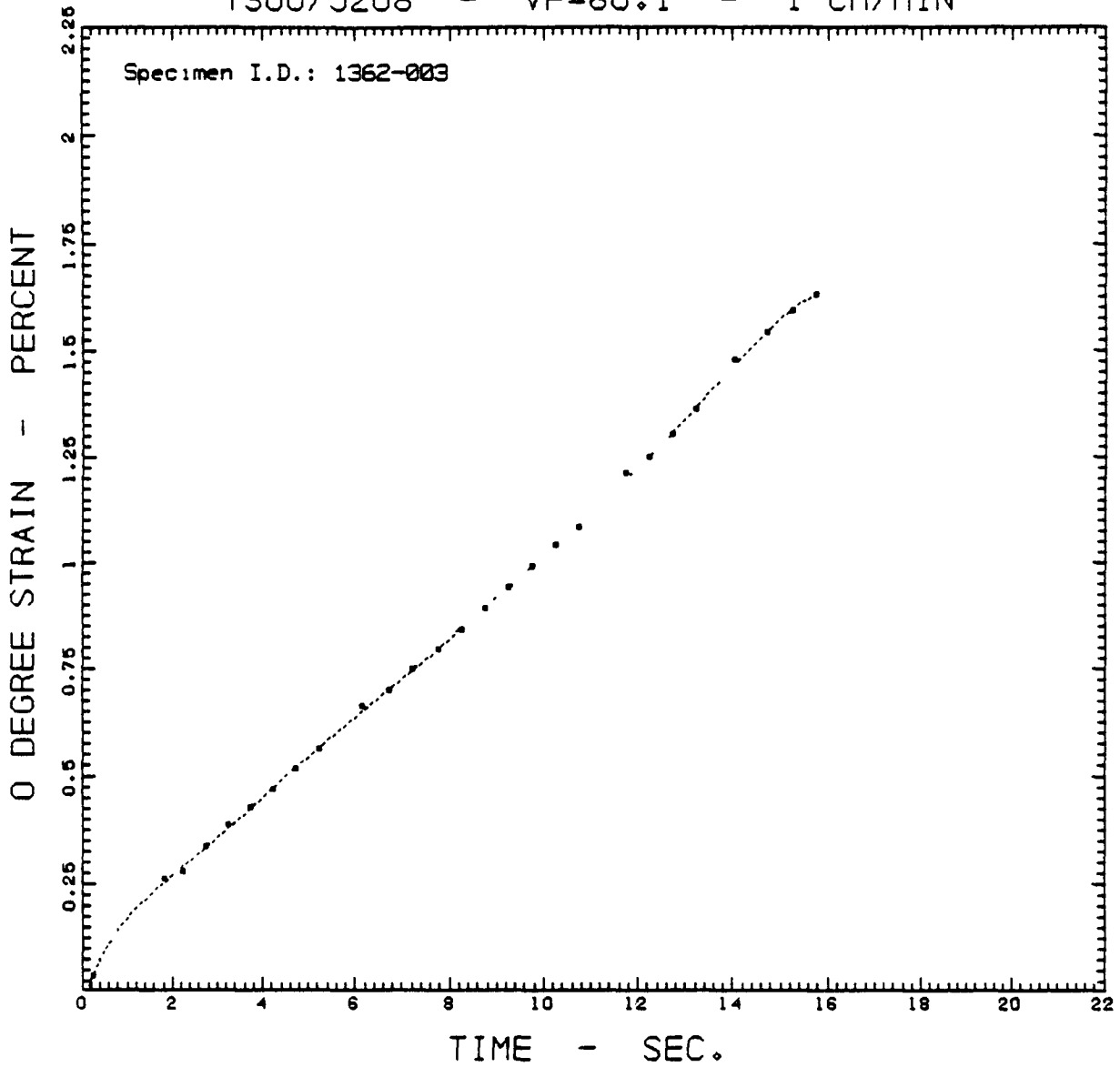

$$\text{STRAIN} = A_0 + A_1 \cdot \text{TIME} + A_2 \cdot \text{TIME}^2 + \dots + A_9 \cdot \text{TIME}^9$$

where:

$$0.2304 \leq \text{TIME} \leq 15.7304$$

A0 = -0.3391E-01	A4 = -0.2116E-01	A7 = 0.1550E-04
A1 = 0.3451E+00	A5 = 0.3120E-02	A8 = -0.4660E-06
A2 = -0.2078E+00	A6 = -0.2837E-03	A9 = 0.5901E-08
A3 = 0.8732E-01		

Multiple Correlation Coefficient = 0.999830; No. of Data Points = 27

T300/5208 - VF=60.1 - 1 CM/MIN

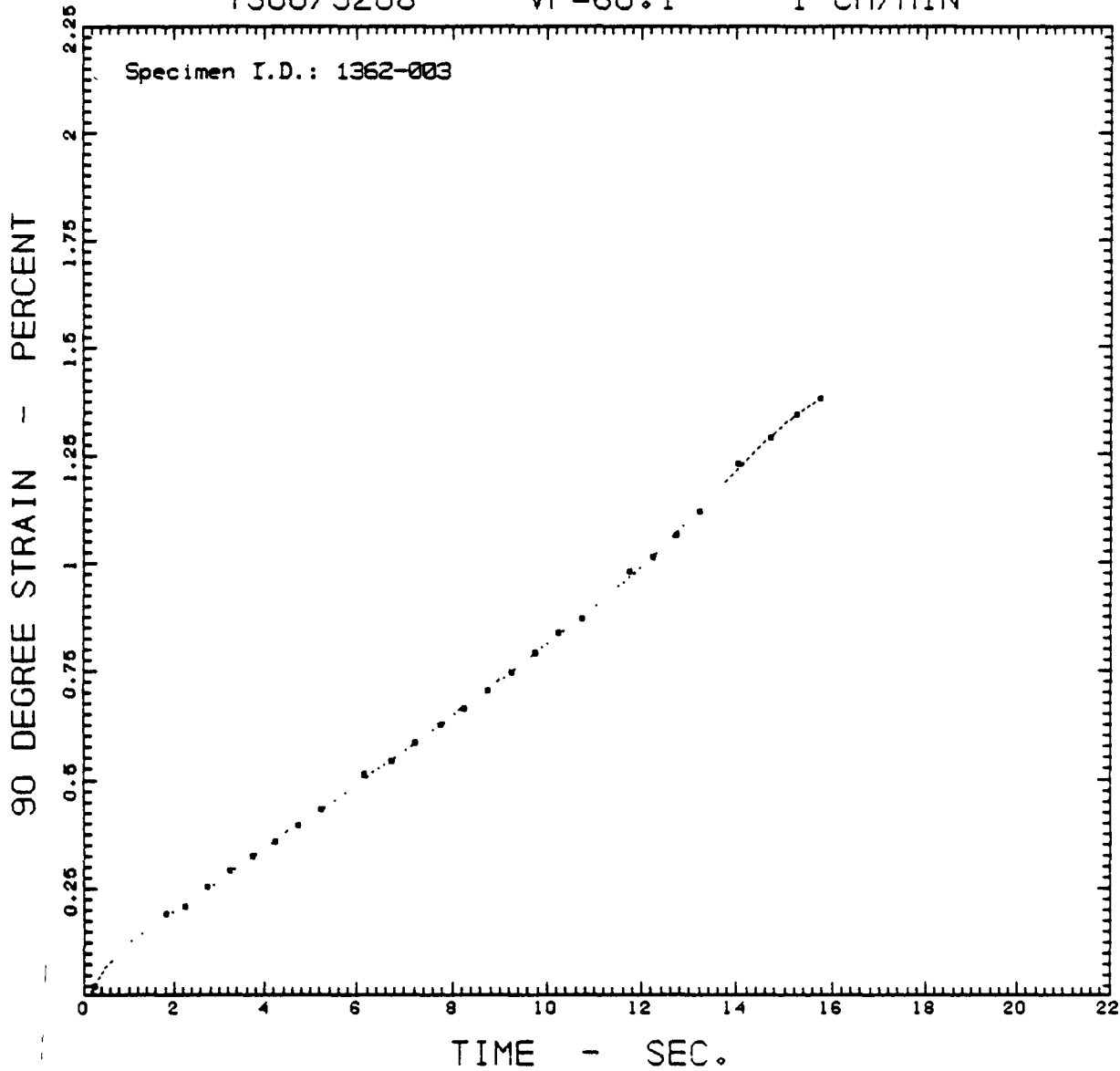

$$\text{STRAIN} = A_0 + A_1 \cdot \text{TIME} + A_2 \cdot \text{TIME}^2 + \dots + A_9 \cdot \text{TIME}^9$$

where:

$$0.2304 \leq \text{TIME} \leq 15.7304$$

A0 = -0.2489E-01	A4 = -0.1728E-01	A7 = 0.1412E-04
A1 = 0.2485E+00	A5 = 0.2656E-02	A8 = -0.4363E-06
A2 = -0.1532E+00	A6 = -0.2504E-03	A9 = 0.5669E-08
A3 = 0.6799E-01		

Multiple Correlation Coefficient = 0.999826; No. of Data Points = 27

T300/5208 - VF=60.1 - 1 CM/MIN

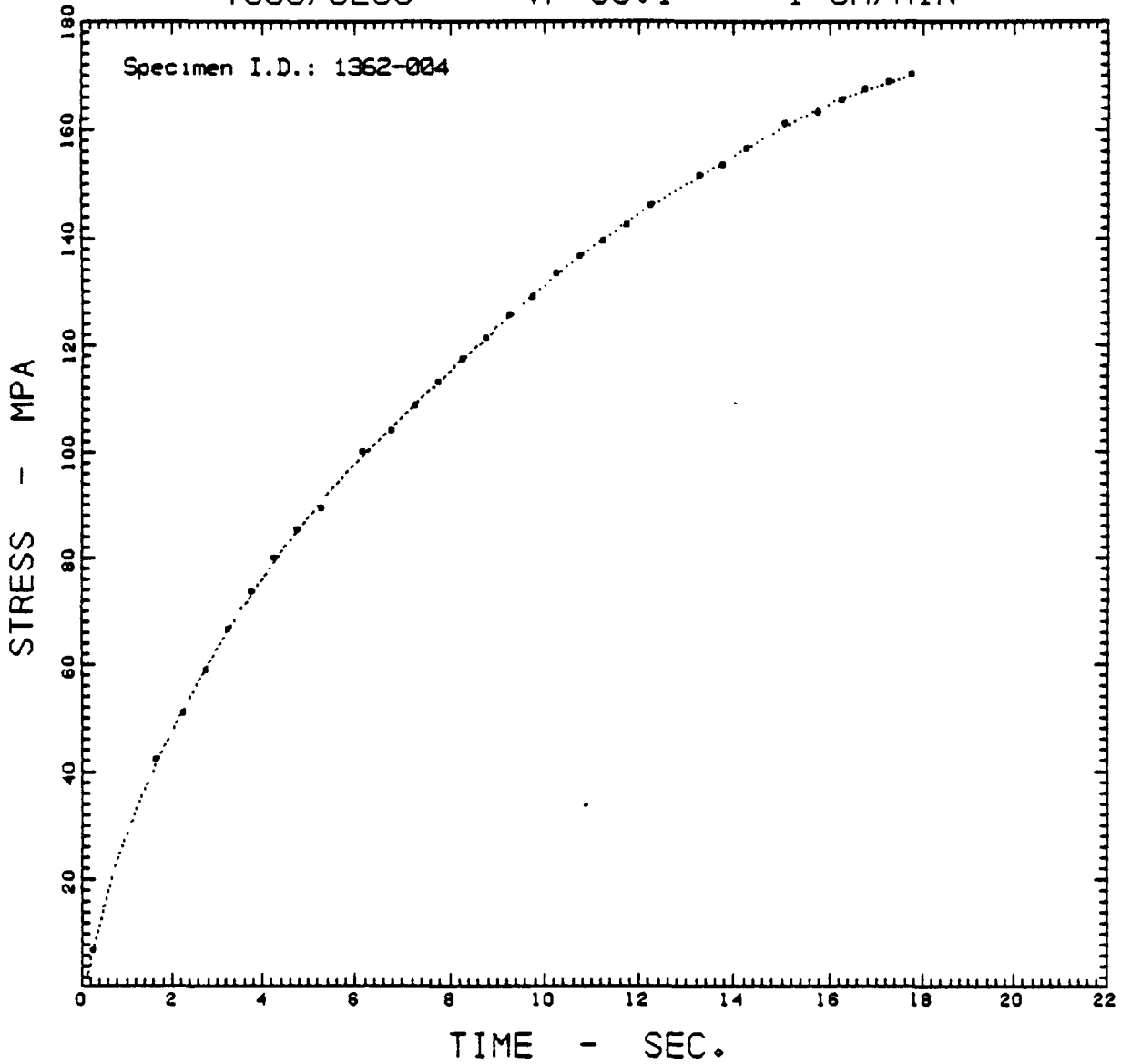

$$\text{STRESS} = A_0 + A_1 \cdot \text{TIME} + A_2 \cdot \text{TIME}^2 + \dots + A_9 \cdot \text{TIME}^9$$

where:

$$0.2435 \leq \text{TIME} \leq 17.7435$$

A0 = -0.3241E+01	A4 = -0.1741E+01	A7 = 0.1117E-02
A1 = 0.4614E+02	A5 = 0.2477E+00	A8 = -0.3163E-04
A2 = -0.1993E+02	A6 = -0.2155E-01	A9 = 0.3768E-06
A3 = 0.7472E+01		

Multiple Correlation Coefficient = 0.999900; No. of Data Points = 31

T300/5208 - VF=60.1 - 1 CM/MIN

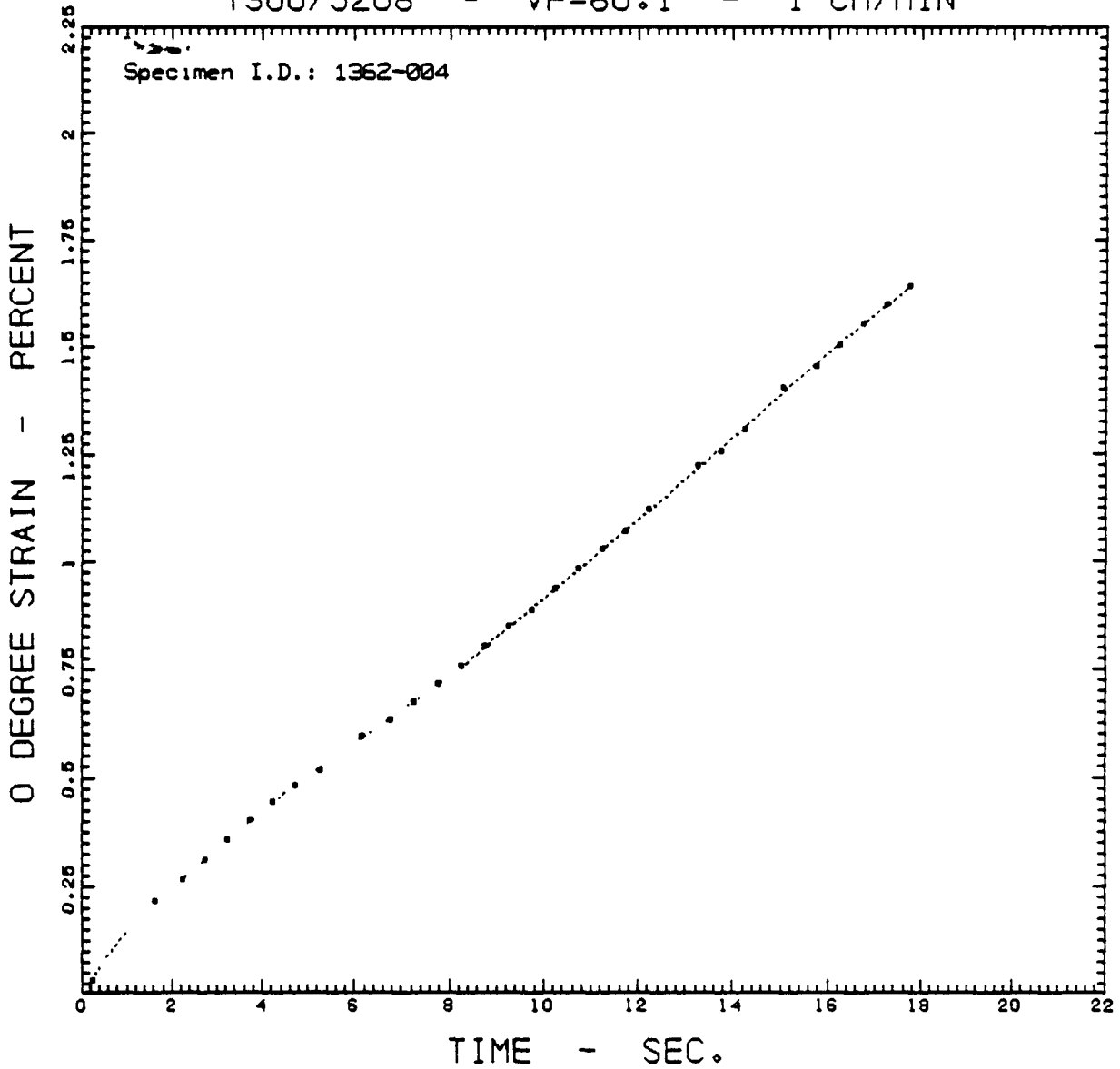

$$\text{STRAIN} = A_0 + A_1 \cdot \text{TIME} + A_2 \cdot \text{TIME}^2 + \dots + A_9 \cdot \text{TIME}^9$$

where:

$$0.2435 \leq \text{TIME} \leq 17.7435$$

A0 = -0.2134E-01	A4 = -0.1168E-01	A7 = 0.7623E-05
A1 = 0.2506E+00	A5 = 0.1681E-02	A8 = -0.2160E-06
A2 = -0.1205E+00	A6 = -0.1469E-03	A9 = 0.2572E-08
A3 = 0.4888E-01		

Multiple Correlation Coefficient = 0.999905; No. of Data Points = 31

T300/5208 - VF=60.1 - 1 CM/MIN

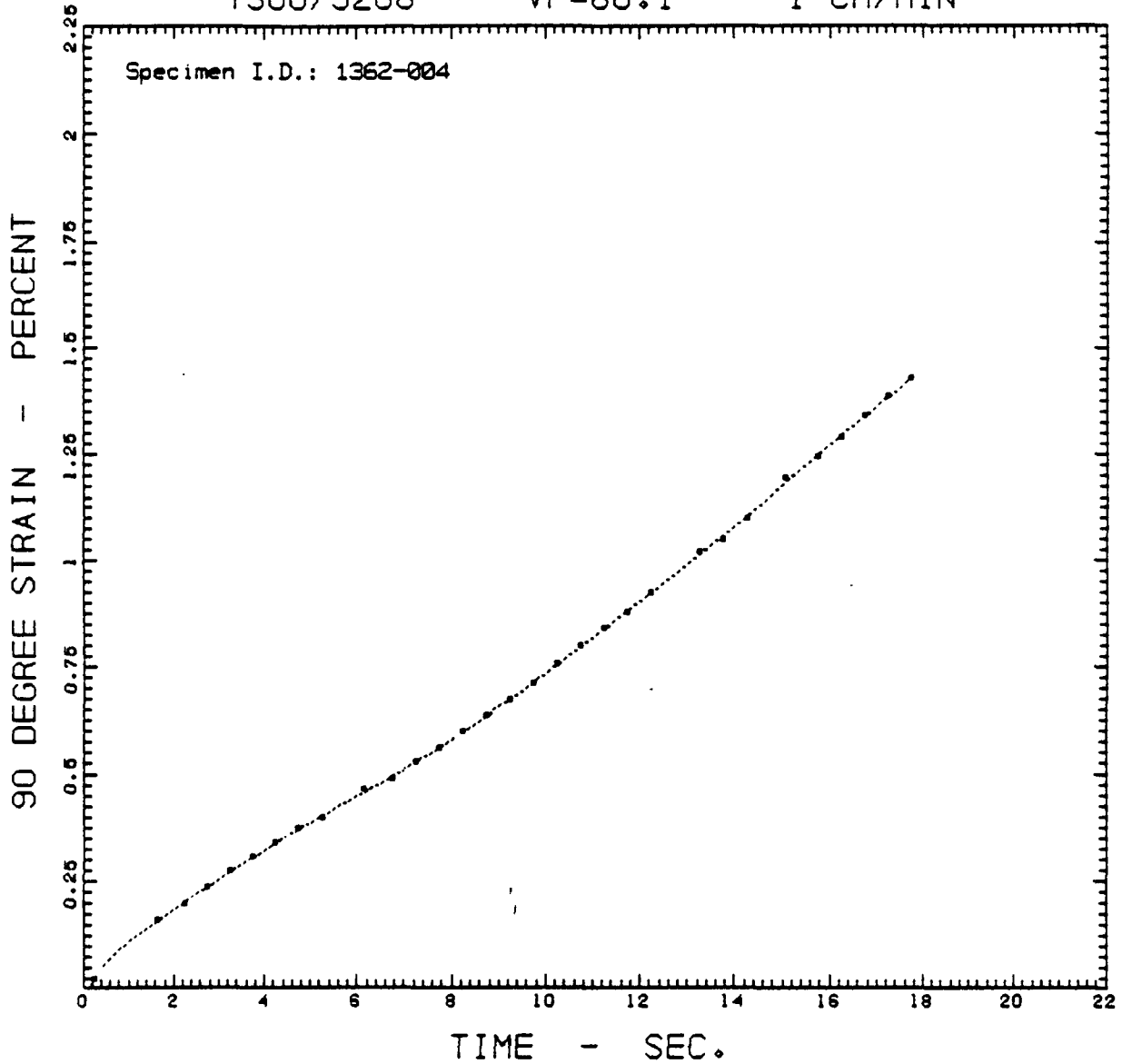

STRAIN = A0 + A1*TIME + A2*TIME^2 + ... + A9*TIME^9

where:

0.2435 < TIME < 17.7435

A0 = -0.1718E-01	A4 = -0.1008E-01	A7 = 0.6627E-05
A1 = 0.1941E+00	A5 = 0.1460E-02	A8 = -0.1875E-06
A2 = -0.9903E-01	A6 = -0.1278E-03	A9 = 0.2228E-08
A3 = 0.4158E-01		

Multiple Correlation Coefficient = 0.999898; No. of Data Points = 31

T300/5208 - VF=60.1 - 1 CM/MIN

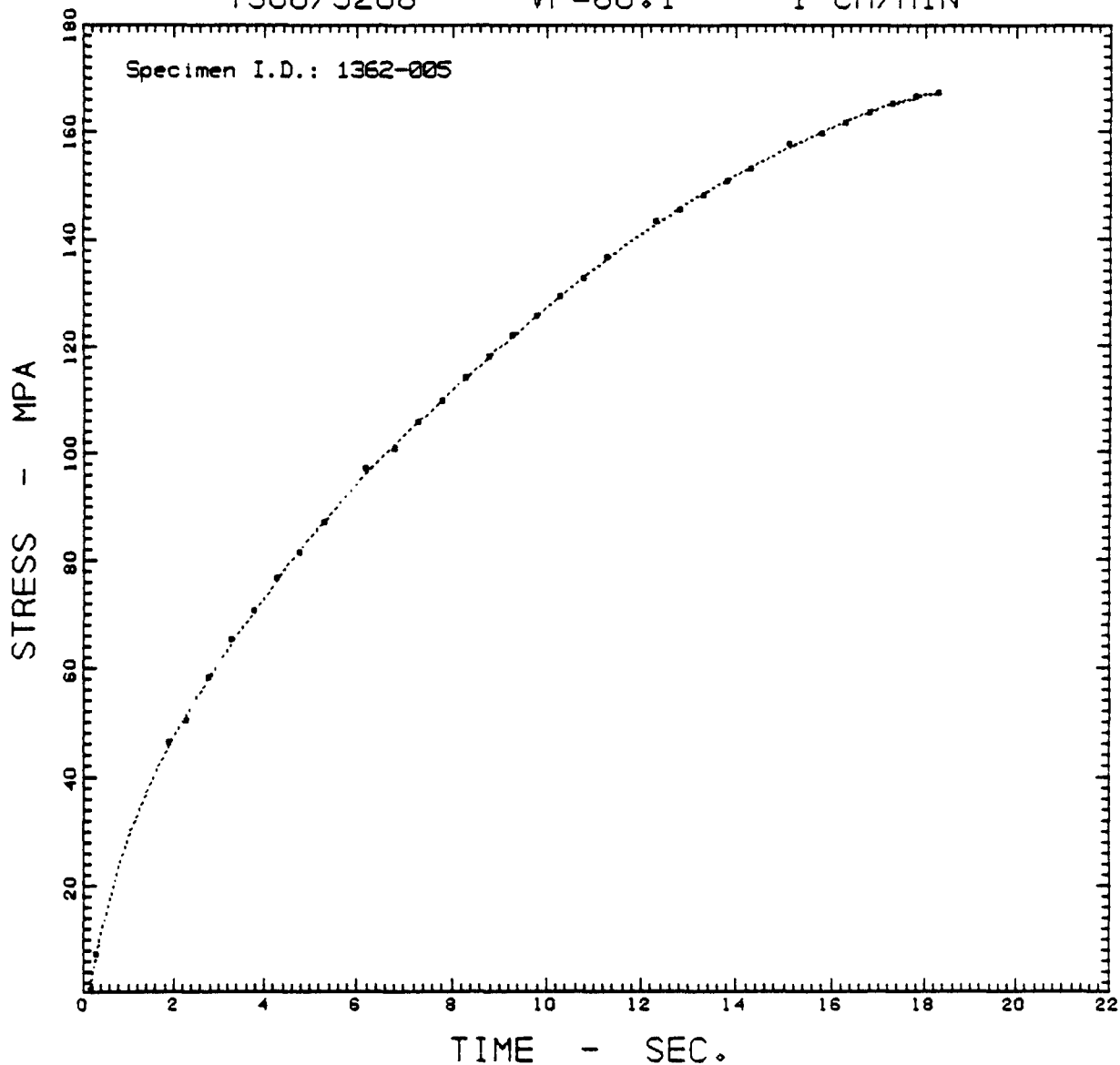

$$\text{STRESS} = A_0 + A_1 \cdot \text{TIME} + A_2 \cdot \text{TIME}^2 + \dots + A_9 \cdot \text{TIME}^9$$

where:

$$0.2817 \leq \text{TIME} \leq 18.2817$$

A0 = -0.5630E+01	A4 = -0.1490E+01	A7 = 0.6973E-03
A1 = 0.5084E+02	A5 = 0.1881E+00	A8 = -0.1819E-04
A2 = -0.2209E+02	A6 = -0.1475E-01	A9 = 0.2009E-06
A3 = 0.7313E+01		

Multiple Correlation Coefficient = 0.999886; No. of Data Points = 32

T300/5208 - VF=60.1 - 1 CM/MIN

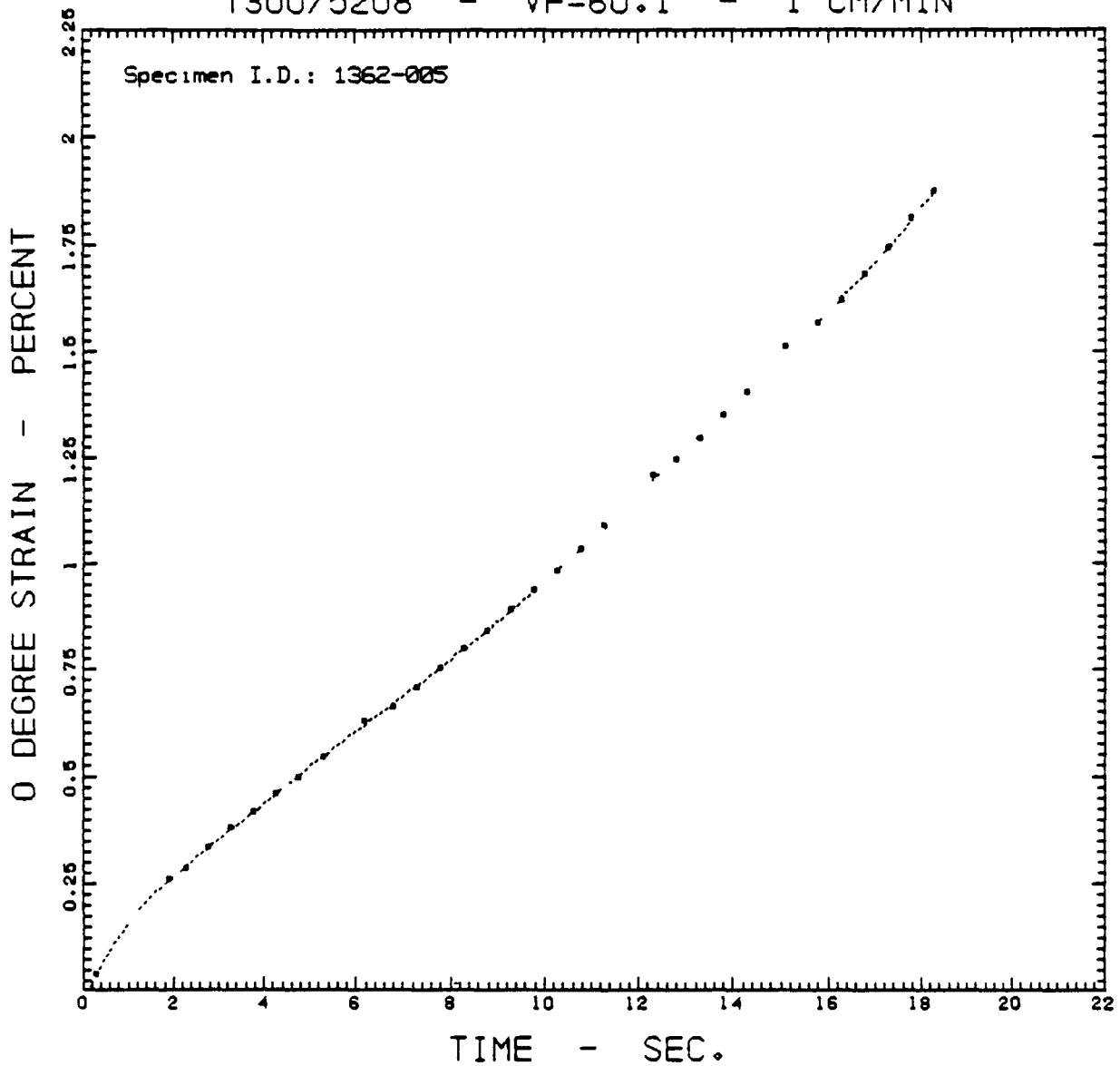

$$\text{STRAIN} = A_0 + A_1 \cdot \text{TIME} + A_2 \cdot \text{TIME}^2 + \dots + A_9 \cdot \text{TIME}^9$$

where:

$$0.2817 \leq \text{TIME} \leq 18.2817$$

A0 = -0.2864E-01	A4 = -0.6721E-02	A7 = 0.2266E-05
A1 = 0.2702E+00	A5 = 0.7746E-03	A8 = -0.5119E-07
A2 = -0.1105E+00	A6 = -0.5442E-04	A9 = 0.4812E-09
A3 = 0.3548E-01		

Multiple Correlation Coefficient = 0.999885; No. of Data Points = 32

T300/5208 - VF=60.1 - 1 CM/MIN

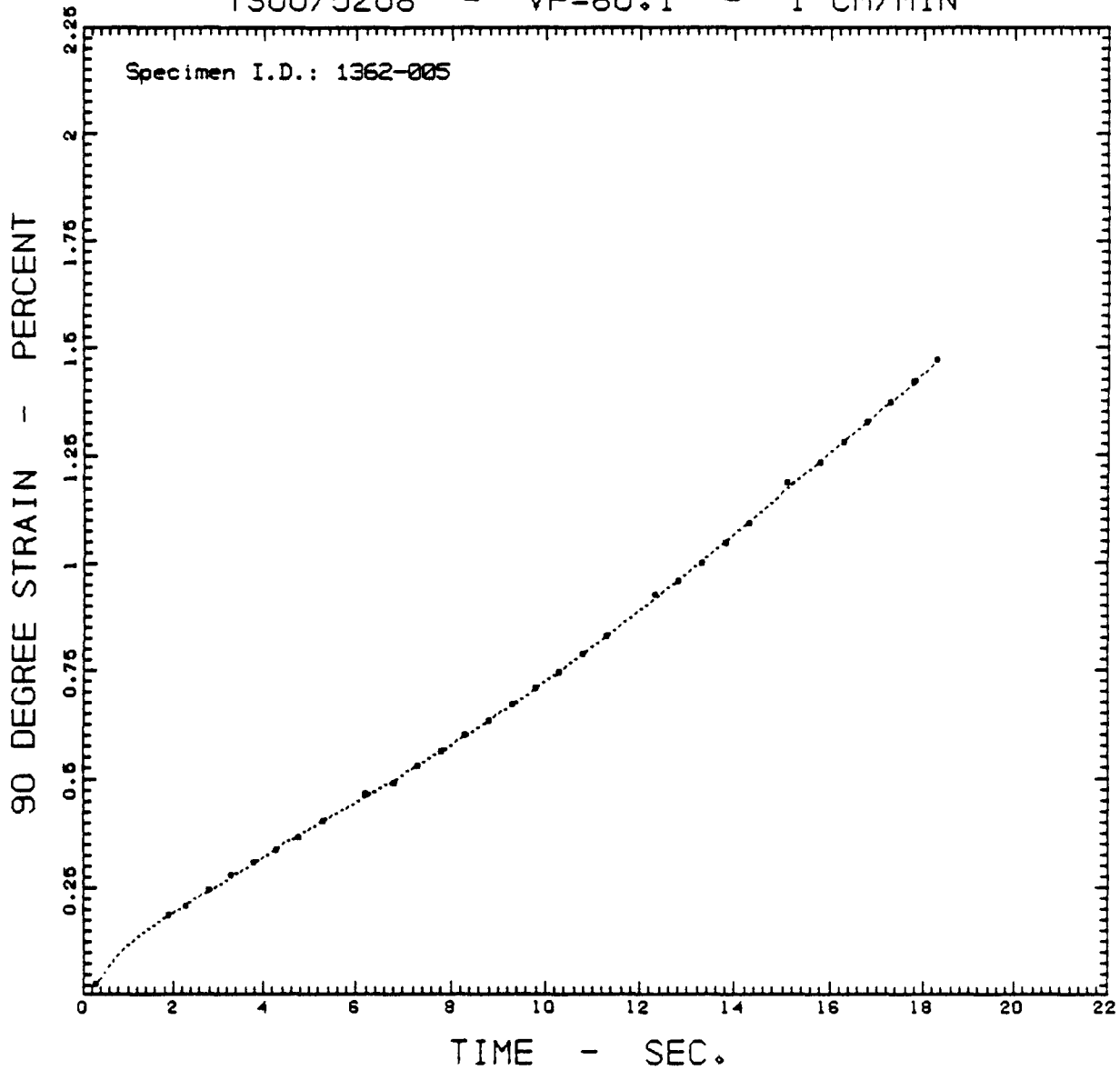

STRAIN = A0 + A1*TIME + A2*TIME^2 + ... + A9*TIME^9

where:

0.2817 < TIME < 18.2817

A0 = -0.2745E-01

A1 = 0.2194E+00

A2 = -0.1071E+00

A3 = 0.3924E-01

A4 = -0.8423E-02

A5 = 0.1105E-02

A6 = -0.8938E-04

A7 = 0.4357E-05

A8 = -0.1174E-06

A9 = 0.1345E-08

Multiple Correlation Coefficient = 0.999895; No. of Data Points = 32

T300/5208 - VF=60.1 - 1 CM/MIN

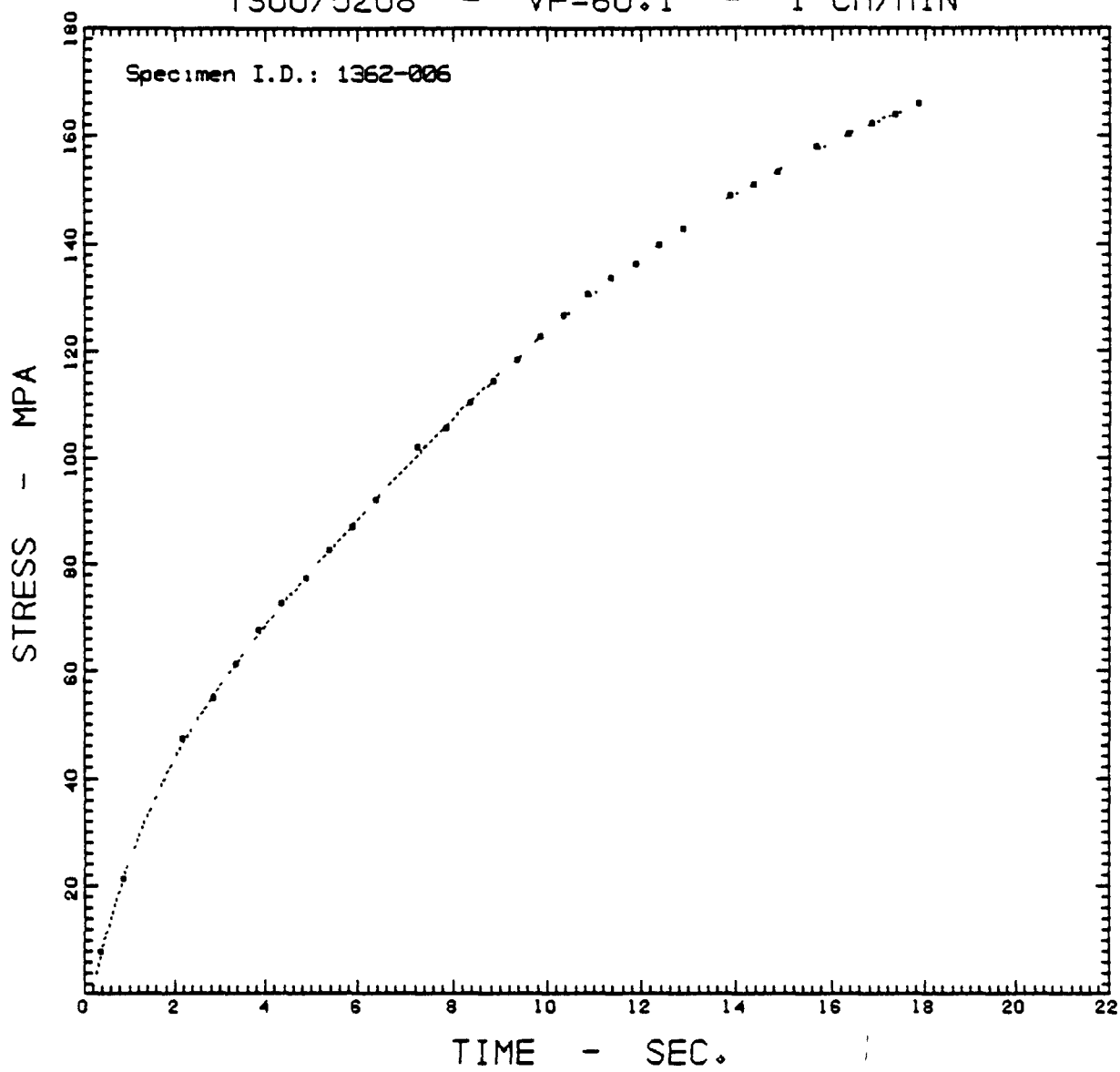

$$\text{STRESS} = A_0 + A_1 \cdot \text{TIME} + A_2 \cdot \text{TIME}^2 + \dots + A_9 \cdot \text{TIME}^9$$

where: $0.3609 \leq \text{TIME} \leq 17.8609$

- | | | |
|------------------|------------------|------------------|
| A0 = -0.5276E+01 | A4 = -0.3418E+00 | A7 = 0.6578E-04 |
| A1 = 0.3951E+02 | A5 = 0.3068E-01 | A8 = -0.1377E-05 |
| A2 = -0.1120E+02 | A6 = -0.1792E-02 | A9 = 0.1252E-07 |
| A3 = 0.2464E+01 | | |

Multiple Correlation Coefficient = 0.999904; No. of Data Points = 31

T300/5208 - VF=60.1 - 1 CM/MIN

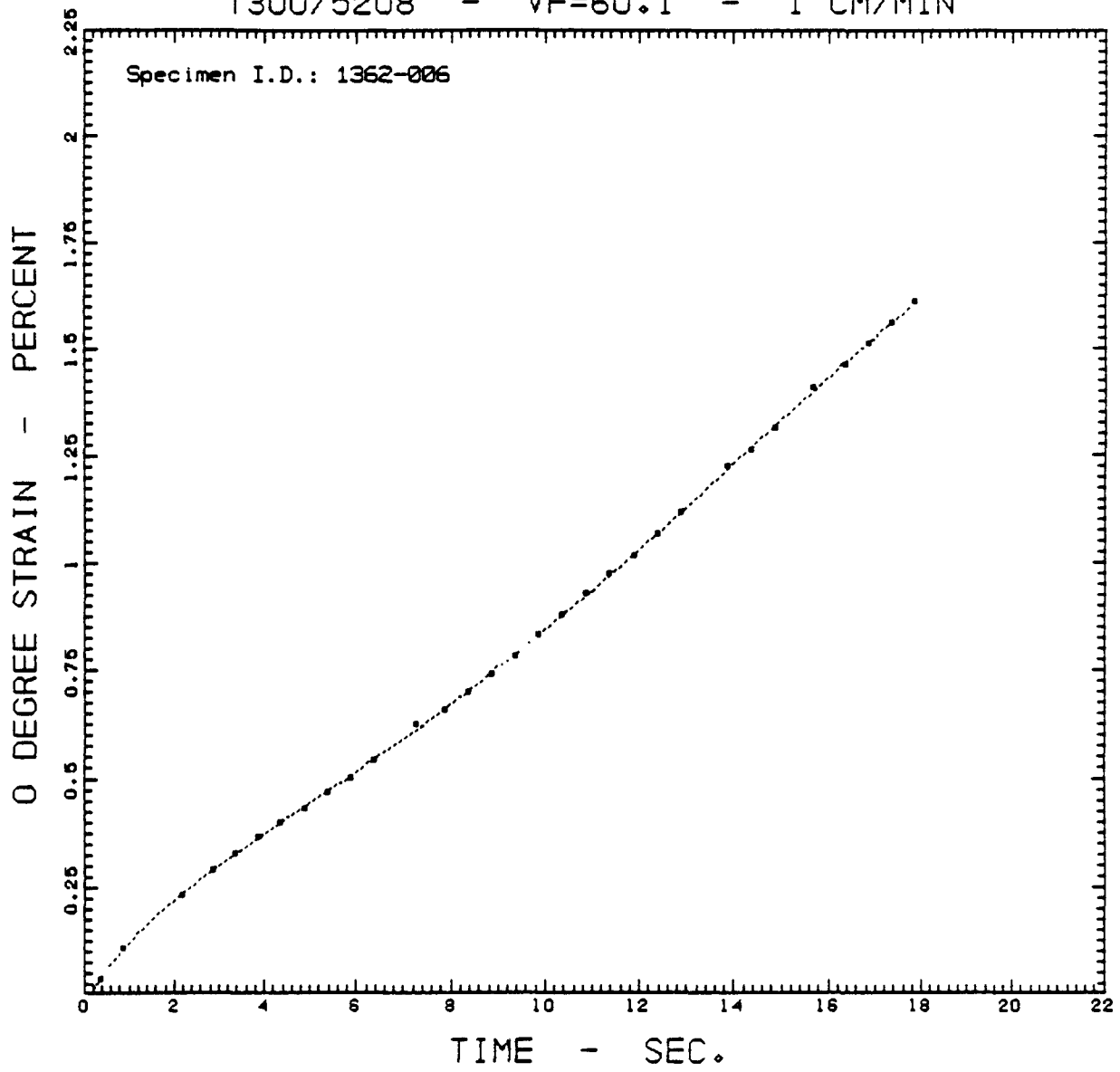

$$\text{STRAIN} = A_0 + A_1 \cdot \text{TIME} + A_2 \cdot \text{TIME}^2 + \dots + A_9 \cdot \text{TIME}^9$$

where:

$$0.3609 \leq \text{TIME} \leq 17.8609$$

- | | | |
|------------------|------------------|------------------|
| A0 = -0.2588E-01 | A4 = -0.3598E-02 | A7 = 0.2218E-05 |
| A1 = 0.1906E+00 | A5 = 0.4905E-03 | A8 = -0.6378E-07 |
| A2 = -0.5765E-01 | A6 = -0.4241E-04 | A9 = 0.7729E-09 |
| A3 = 0.1750E-01 | | |

Multiple Correlation Coefficient = 0.999907; No. of Data Points = 31

T300/5208 - VF=60.1 - 1 CM/MIN

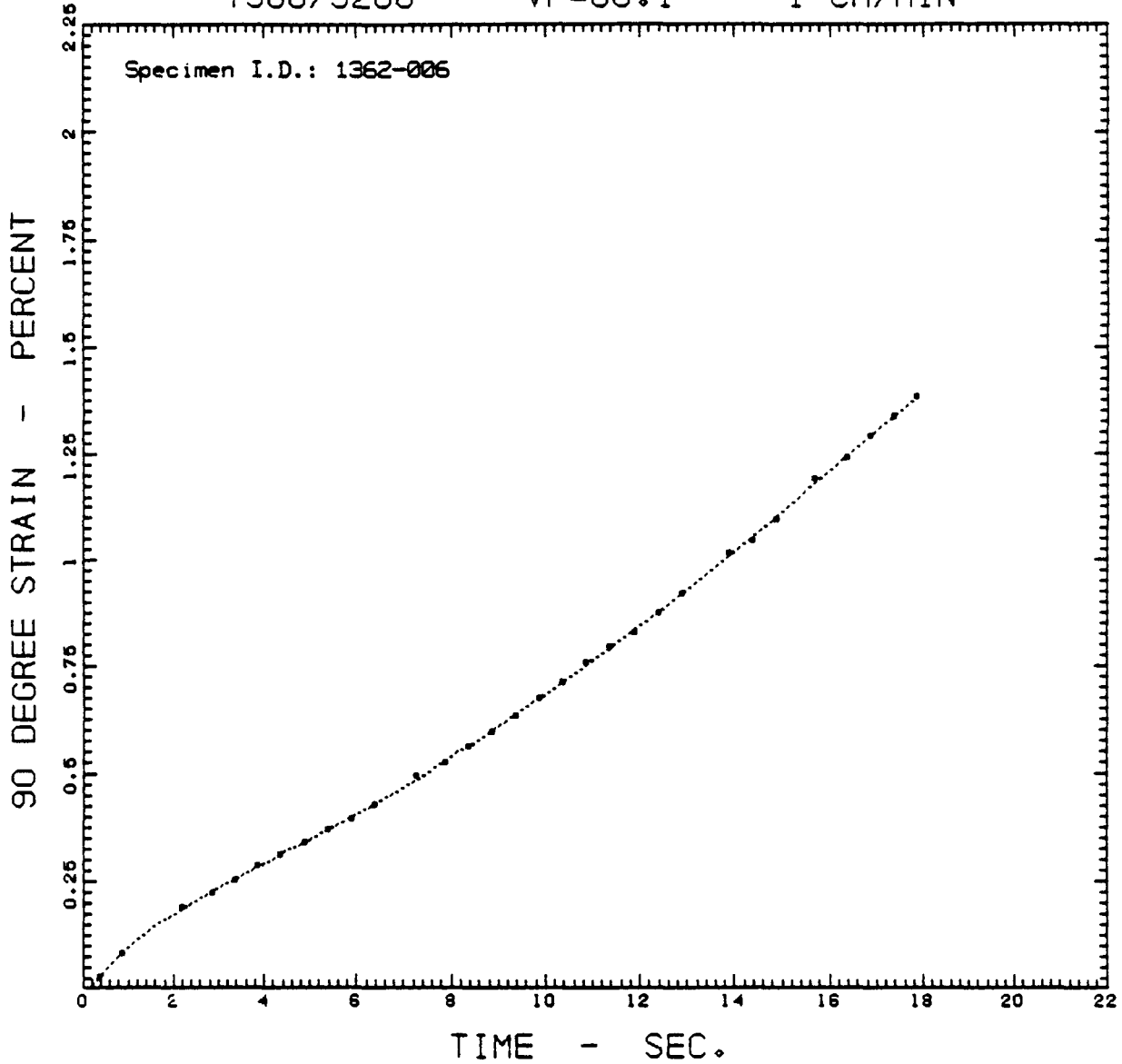

STRAIN = A0 + A1*TIME + A2*TIME^2 + ... + A9*TIME^9

where:

0.3609 < TIME < 17.8609

A0 = -0.2678E-01	A4 = -0.2985E-02	A7 = 0.1636E-05
A1 = 0.1650E+00	A5 = 0.3824E-03	A8 = -0.4669E-07
A2 = -0.5422E-01	A6 = -0.3186E-04	A9 = 0.5649E-09
A3 = 0.1570E-01		

Multiple Correlation Coefficient = 0.999889; No. of Data Points = 31

T300/5208 - VF=60.1 - 1 CM/MIN

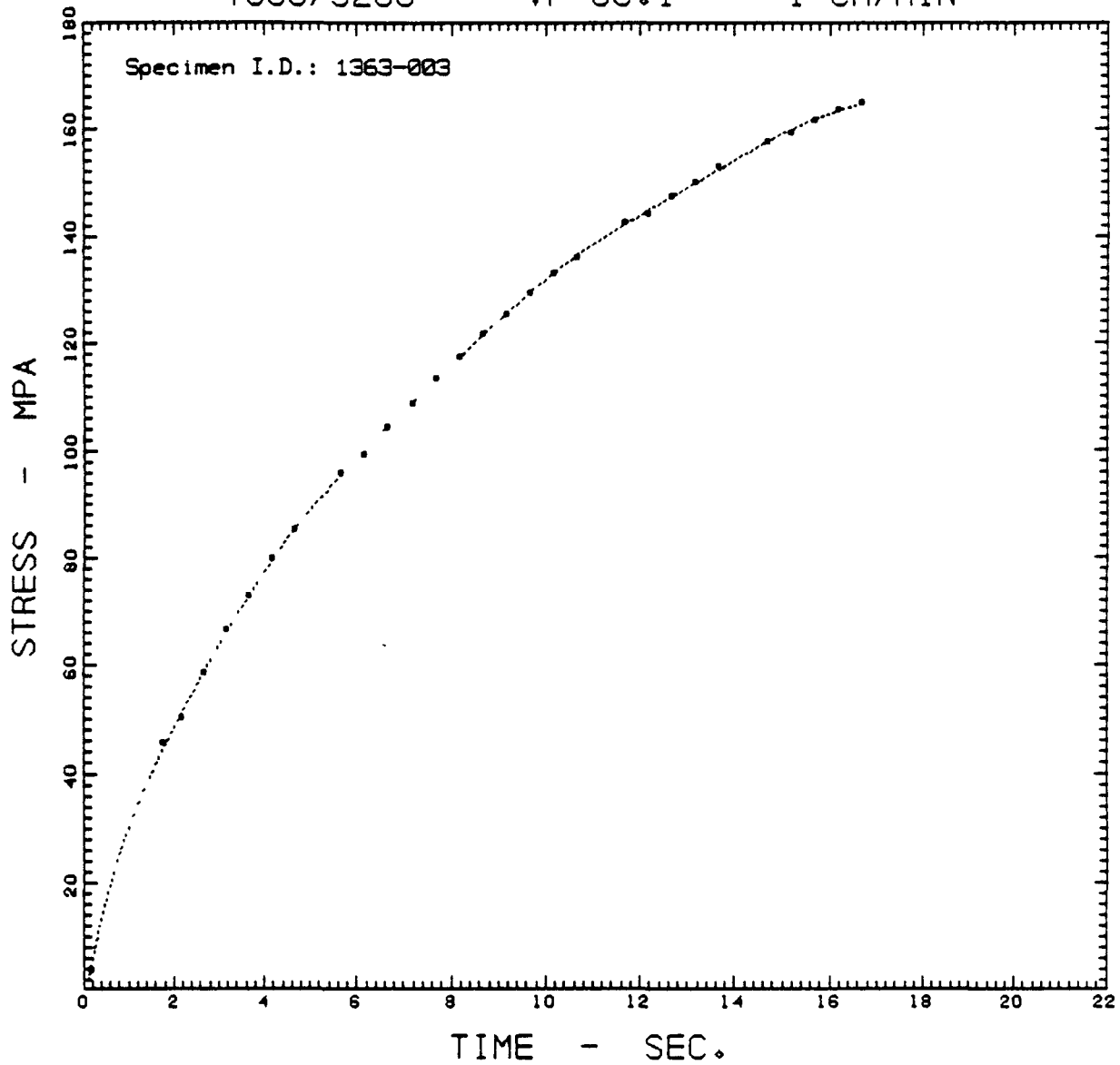

$$\text{STRESS} = A_0 + A_1 \cdot \text{TIME} + A_2 \cdot \text{TIME}^2 + \dots + A_9 \cdot \text{TIME}^9$$

where:

$$0.1565 \leq \text{TIME} \leq 16.6565$$

$$A_0 = -0.3641E+01$$

$$A_1 = 0.5317E+02$$

$$A_2 = -0.2811E+02$$

$$A_3 = 0.1163E+02$$

$$A_4 = -0.2874E+01$$

$$A_5 = 0.4281E+00$$

$$A_6 = -0.3885E-01$$

$$A_7 = 0.2099E-02$$

$$A_8 = -0.6204E-04$$

$$A_9 = 0.7717E-06$$

Multiple Correlation Coefficient = 0.999908; No. of Data Points = 29

T300/5208 - VF=60.1 - 1 CM/MIN

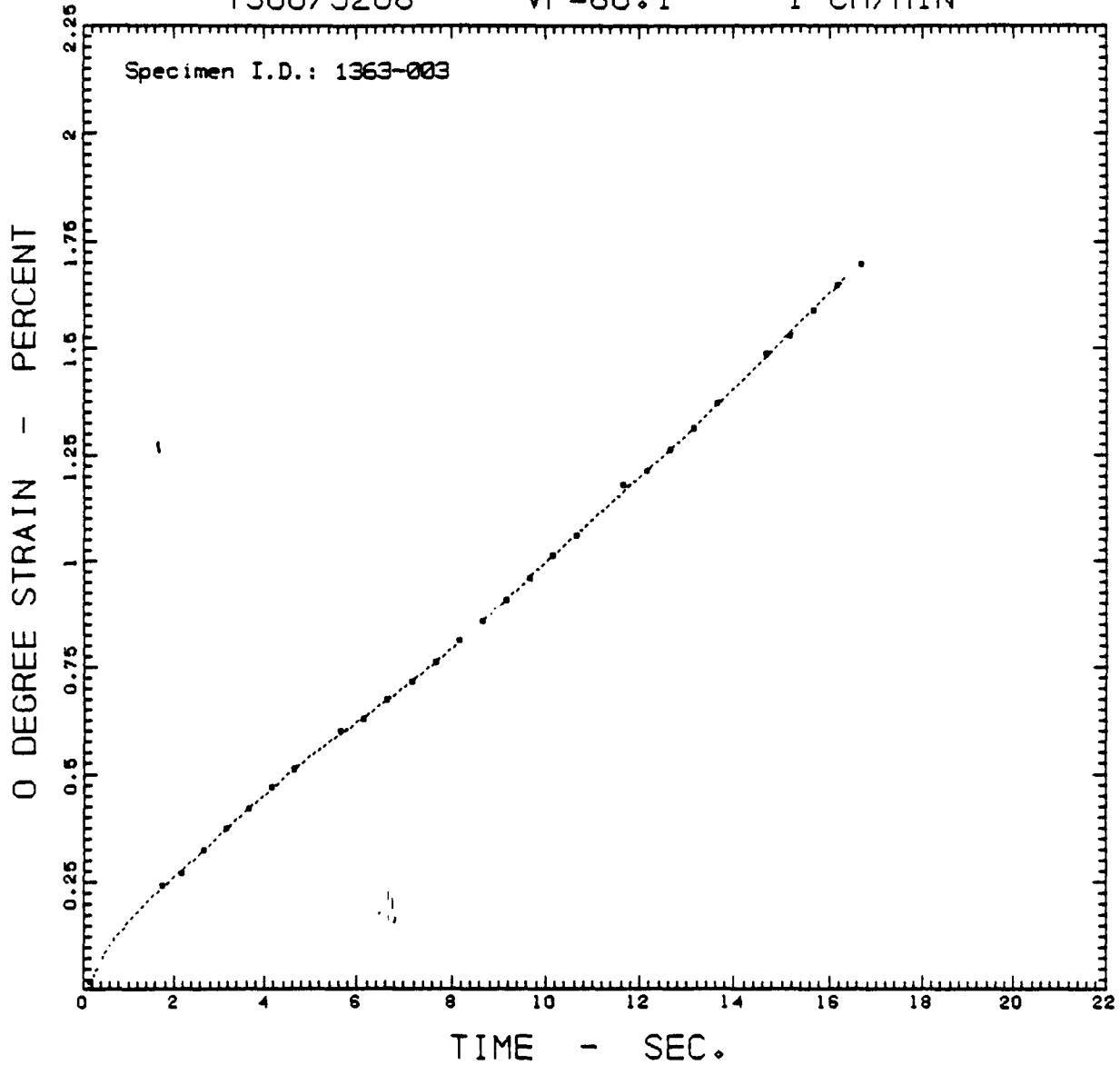

$$\text{STRAIN} = A_0 + A_1 \cdot \text{TIME} + A_2 \cdot \text{TIME}^2 + \dots + A_9 \cdot \text{TIME}^9$$

where:

$$0.1565 \leq \text{TIME} \leq 16.6565$$

A0 = -0.2664E-01	A4 = -0.2163E-01	A7 = 0.1605E-04
A1 = 0.3109E+00	A5 = 0.3268E-02	A8 = -0.4712E-06
A2 = -0.1883E+00	A6 = -0.2977E-03	A9 = 0.5808E-08
A3 = 0.8478E-01		

Multiple Correlation Coefficient = 0.999935; No. of Data Points = 29

T300/5208 - VF=60.1 - 1 CM/MIN

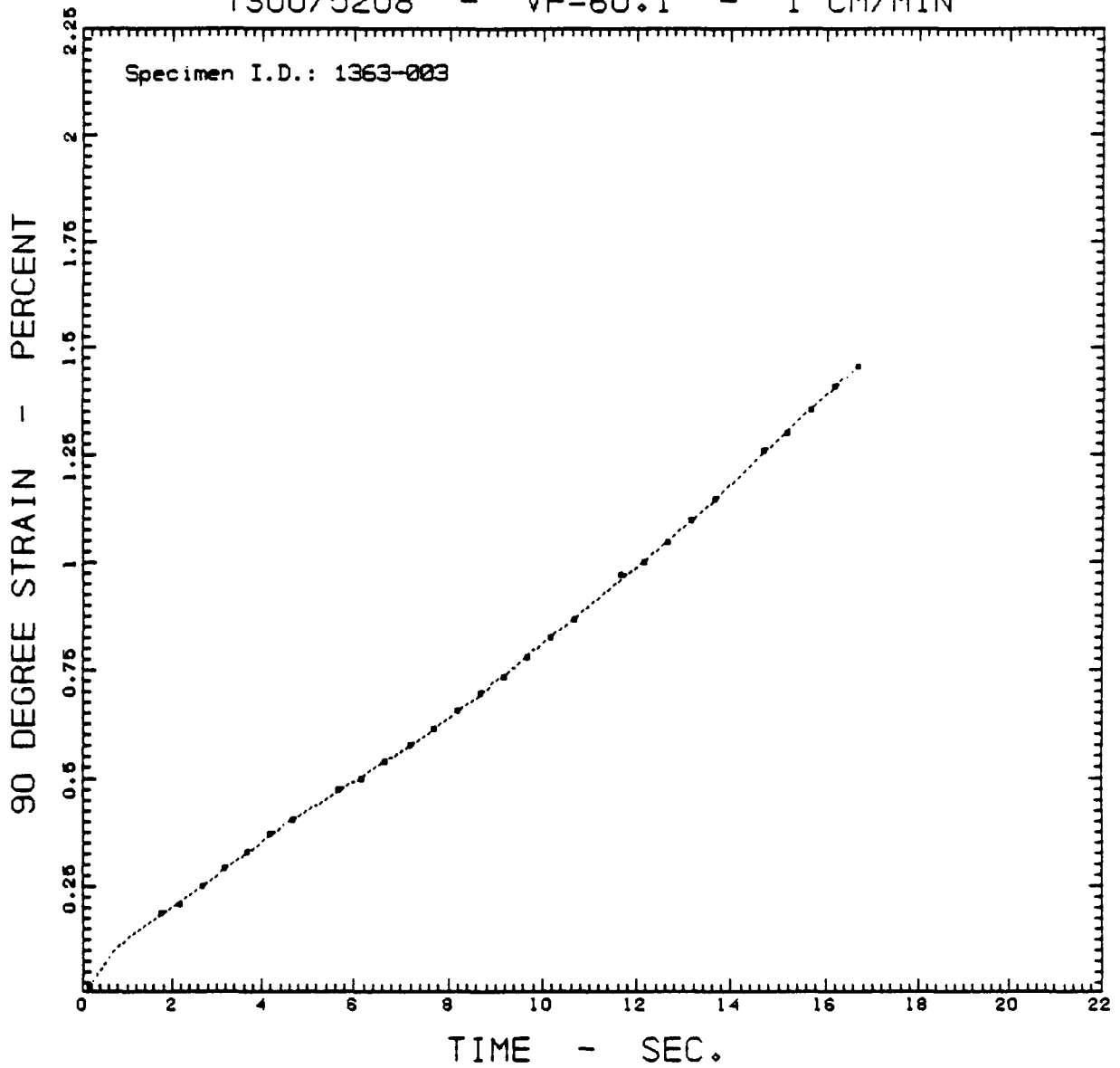

$$\text{STRAIN} = A_0 + A_1 \cdot \text{TIME} + A_2 \cdot \text{TIME}^2 + \dots + A_9 \cdot \text{TIME}^9$$

where:

$$0.1565 \leq \text{TIME} \leq 16.6565$$

$A_0 = -0.2333E-01$	$A_4 = -0.1847E-01$	$A_7 = 0.1307E-04$
$A_1 = 0.2576E+00$	$A_5 = 0.2743E-02$	$A_8 = -0.3791E-06$
$A_2 = -0.1641E+00$	$A_6 = -0.2460E-03$	$A_9 = 0.4619E-08$
$A_3 = 0.7358E-01$		

Multiple Correlation Coefficient = 0.999932; No. of Data Points = 29

T300/5208 - VF=60.1 - 1 CM/MIN

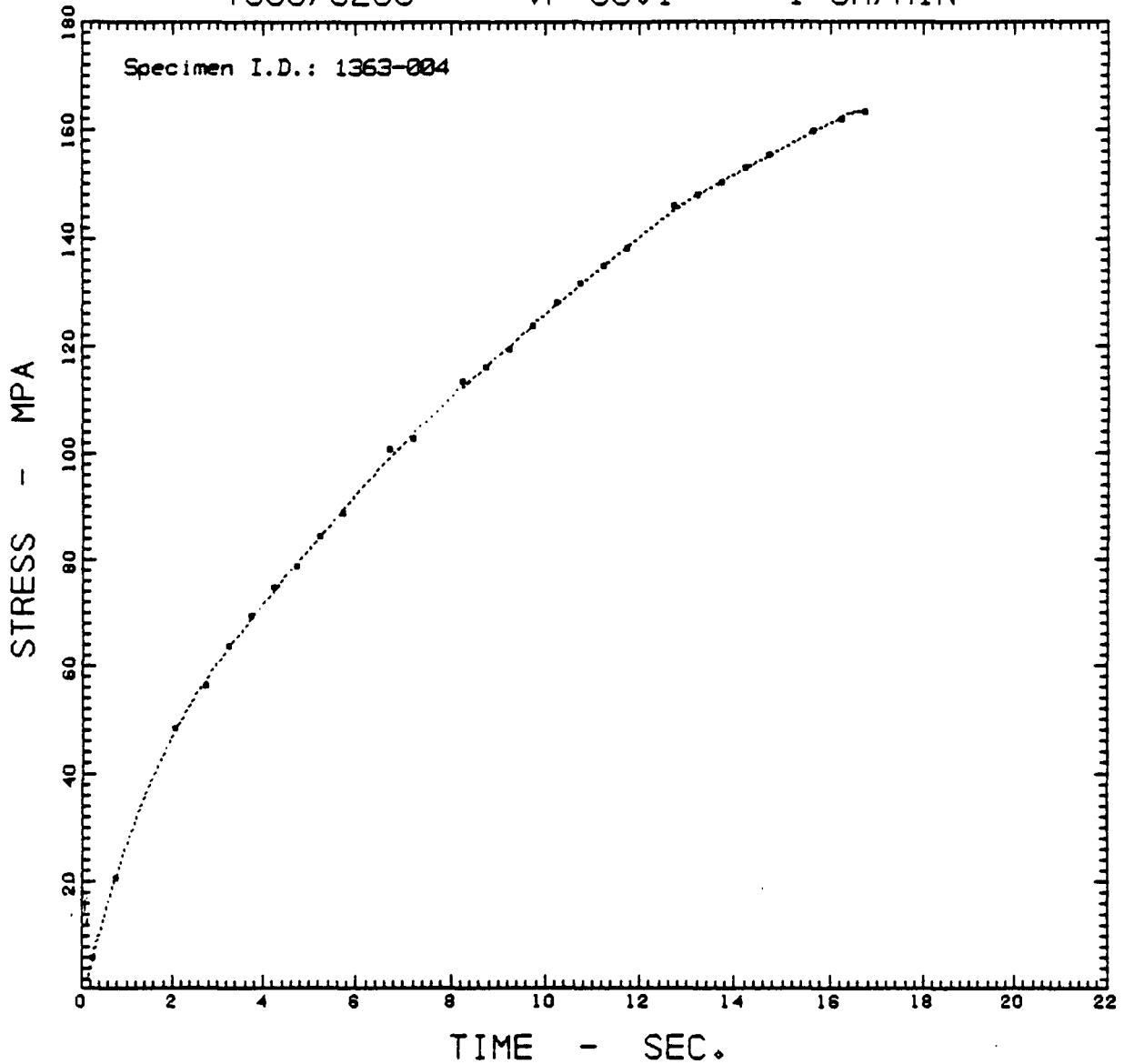

$$\text{STRESS} = A_0 + A_1 \cdot \text{TIME} + A_2 \cdot \text{TIME}^2 + \dots + A_9 \cdot \text{TIME}^9$$

where:

$$0.2304 \leq \text{TIME} \leq 16.7304$$

A0 = -0.2010E+01	A4 = 0.7926E+00	A7 = -0.1062E-02
A1 = 0.3480E+02	A5 = -0.1611E+00	A8 = 0.3441E-04
A2 = -0.4440E+01	A6 = 0.1743E-01	A9 = -0.4610E-06
A3 = -0.1381E+01		

Multiple Correlation Coefficient = 0.999829; No. of Data Points = 28

T300/5208 - VF=60.1 - 1 CM/MIN

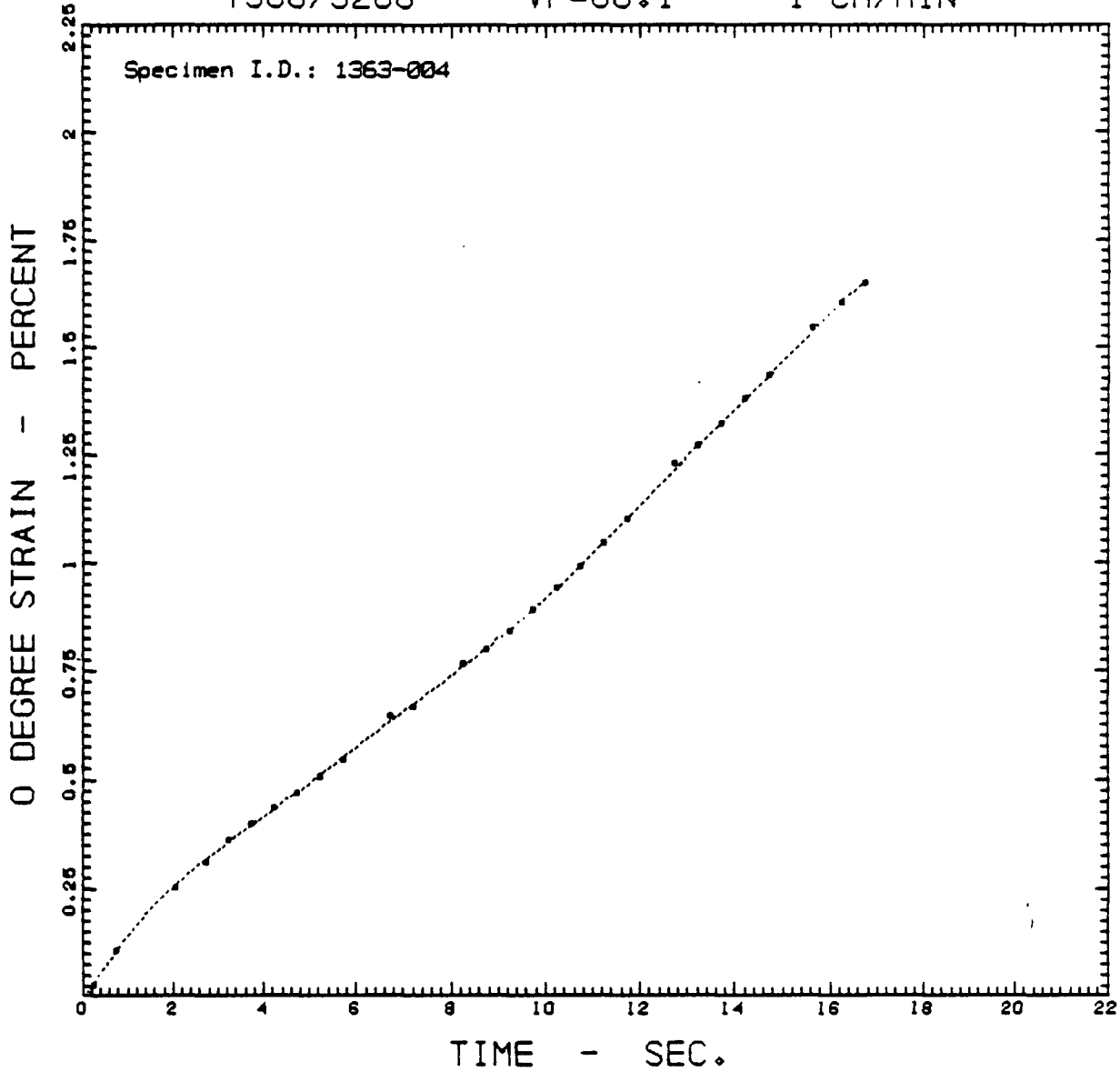

$$\text{STRAIN} = A_0 + A_1 \cdot \text{TIME} + A_2 \cdot \text{TIME}^2 + \dots + A_9 \cdot \text{TIME}^9$$

where:

$$0.2304 \leq \text{TIME} \leq 16.7304$$

$$A_0 = -0.4780E-02$$

$$A_1 = 0.1495E+00$$

$$A_2 = 0.1379E-01$$

$$A_3 = -0.2444E-01$$

$$A_4 = 0.8968E-02$$

$$A_5 = -0.1646E-02$$

$$A_6 = 0.1719E-03$$

$$A_7 = -0.1033E-04$$

$$A_8 = 0.3328E-06$$

$$A_9 = -0.4452E-08$$

Multiple Correlation Coefficient = 0.999871; No. of Data Points = 28

T300/5208 - VF=60.1 - 1 CM/MIN

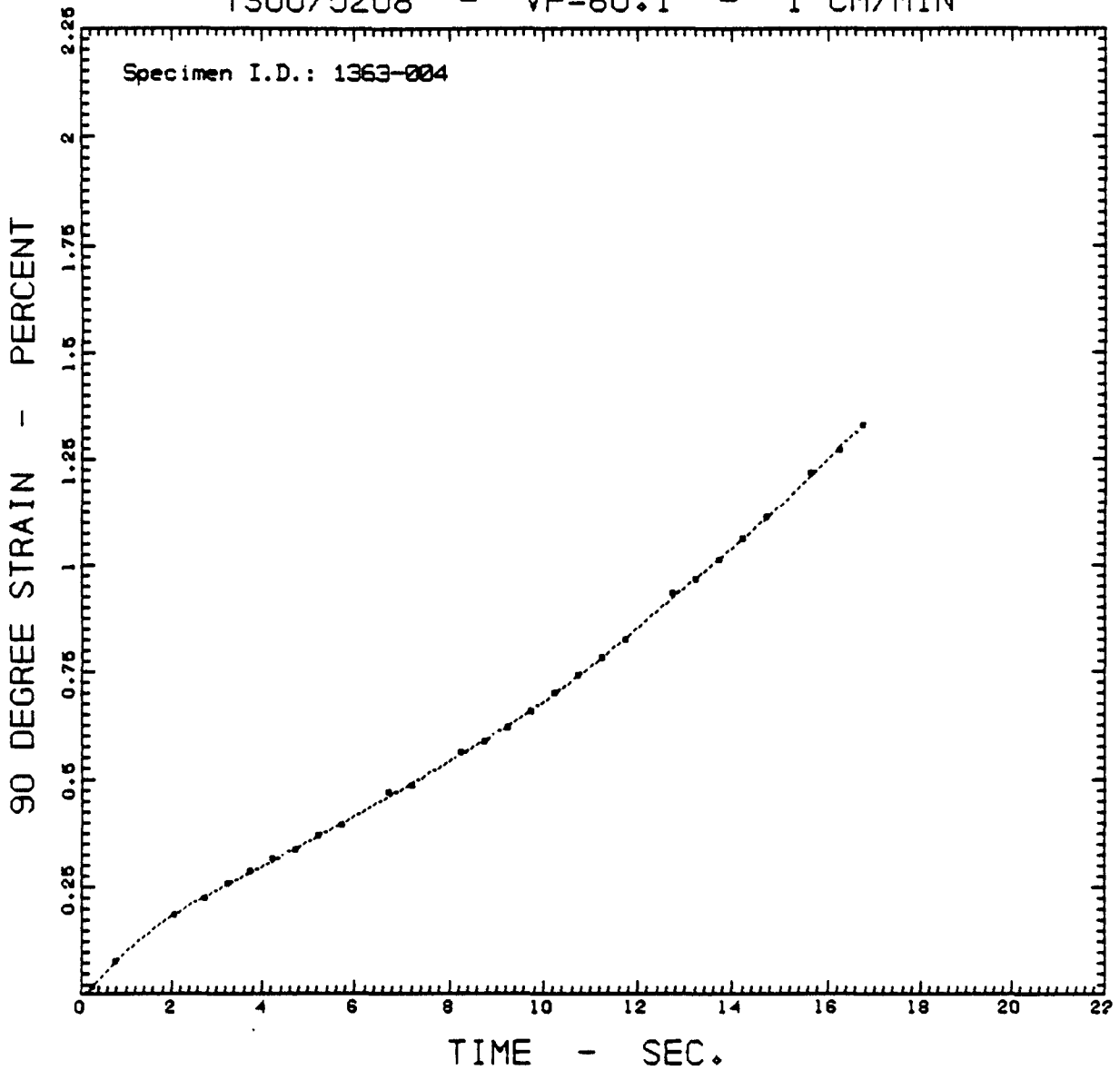

$$\text{STRAIN} = A_0 + A_1 \cdot \text{TIME} + A_2 \cdot \text{TIME}^2 + \dots + A_9 \cdot \text{TIME}^9$$

where:

$$0.2304 \leq \text{TIME} \leq 16.7304$$

A0 = -0.6560E-02	A4 = 0.6995E-02	A7 = -0.8014E-05
A1 = 0.1131E+00	A5 = -0.1292E-02	A8 = 0.2552E-06
A2 = 0.8427E-02	A6 = 0.1345E-03	A9 = -0.3367E-08
A3 = -0.1854E-01		

Multiple Correlation Coefficient = 0.999870; No. of Data Points = 28

T300/5208 - VF=60.1 - 1 CM/MIN

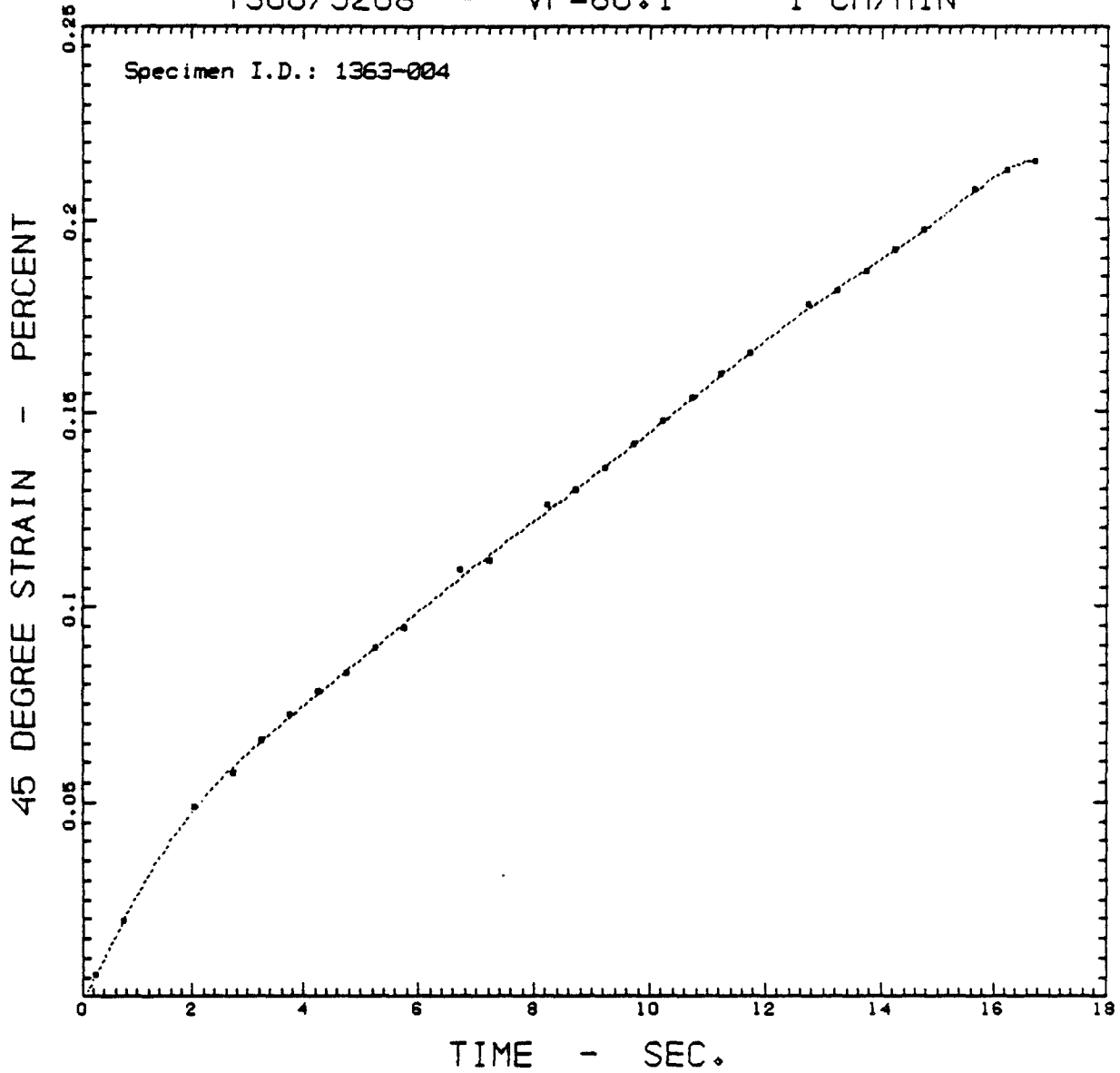

$$\text{STRAIN} = A_0 + A_1 \cdot \text{TIME} + A_2 \cdot \text{TIME}^2 + \dots + A_9 \cdot \text{TIME}^9$$

where:

$$0.2304 = \langle \text{TIME} \rangle = \langle 16.7304$$

$A_0 = -0.8350E-03$	$A_4 = 0.1808E-02$	$A_7 = -0.1948E-05$
$A_1 = 0.2803E-01$	$A_5 = -0.3218E-03$	$A_8 = 0.6218E-07$
$A_2 = 0.3389E-02$	$A_6 = 0.3288E-04$	$A_9 = -0.8280E-09$
$A_3 = -0.5167E-02$		

Multiple Correlation Coefficient = 0.999858; No. of Data Points = 28

DISCLAIMER

This document was prepared as an account of work sponsored by an agency of the United States Government. Neither the United States Government nor the University of California nor any of their employees, makes any warranty, express or implied, or assumes any legal liability or responsibility for the accuracy, completeness, or usefulness of any information, apparatus, product, or process disclosed, or represents that its use would not infringe privately owned rights. Reference herein to any specific commercial products, process, or service by trade name, trademark, manufacturer, or otherwise, does not necessarily constitute or imply its endorsement, recommendation, or favoring by the United States Government or the University of California. The views and opinions of authors expressed herein do not necessarily state or reflect those of the United States Government thereof, and shall not be used for advertising or product endorsement purposes.

DO NOT MICROFILM
COVER

Printed in the United States of America
Available from
National Technical Information Service
U.S. Department of Commerce
5285 Port Royal Road
Springfield, VA 22161
Price: Printed Copy \$; Microfiche \$4.50

<u>Page Range</u>	<u>Domestic Price</u>	<u>Page Range</u>	<u>Domestic Price</u>
001-025	\$ 7.00	326-350	\$ 26.50
026-050	8.50	351-375	28.00
051-075	10.00	376-400	29.50
076-100	11.50	401-426	31.00
101-125	13.00	427-450	32.50
126-150	14.50	451-475	34.00
151-175	16.00	476-500	35.50
176-200	17.50	501-525	37.00
201-225	19.00	526-550	38.50
226-250	20.50	551-575	40.00
251-275	22.00	576-600	41.50
276-300	23.50	601-up ¹	
301-325	25.00		

¹Add 1.50 for each additional 25 page increment, or portion thereof from 601 pages up.

Technical Information Department • Lawrence Livermore Laboratory
University of California • Livermore, California 94550

**DO NOT MICROFILM
COVER**

