

273  
1/29/81  
T.S.

②

Di. 2240  
ORN/Sub-7381/1  
Distribution Category UC-95d

R-1545

MASTER

ENERGY

NOIHTAKTHTHON

RESEARCH AND DEVELOPMENT OF A  
HIGH EFFICIENCY GAS-FIRED WATER HEATER

VOLUME 1

FINAL REPORT SUMMARY

MAY 1980

Prepared by:

*outside  
flow*

Andrew D. Vasilakis  
John F. Pearson  
Dr. Joseph Gerstmann

ADVANCED MECHANICAL TECHNOLOGY, INC.  
141 California Street  
Newton, Massachusetts 02158

951 1327

Work performed for

OAK RIDGE NATIONAL LABORATORY

operated by

UNION CARBIDE CORPORATION

for the

**U. S. DEPARTMENT OF ENERGY**

**Office of Buildings and Community Systems**

DISTRIBUTION OF THIS DOCUMENT IS UNLIMITED

## DISCLAIMER

**This report was prepared as an account of work sponsored by an agency of the United States Government. Neither the United States Government nor any agency Thereof, nor any of their employees, makes any warranty, express or implied, or assumes any legal liability or responsibility for the accuracy, completeness, or usefulness of any information, apparatus, product, or process disclosed, or represents that its use would not infringe privately owned rights. Reference herein to any specific commercial product, process, or service by trade name, trademark, manufacturer, or otherwise does not necessarily constitute or imply its endorsement, recommendation, or favoring by the United States Government or any agency thereof. The views and opinions of authors expressed herein do not necessarily state or reflect those of the United States Government or any agency thereof.**

## **DISCLAIMER**

**Portions of this document may be illegible in electronic image products. Images are produced from the best available original document.**

Printed in the United States of America. Available from  
National Technical Information Service  
U.S. Department of Commerce  
5285 Port Royal Road, Springfield, Virginia 22161

NTIS price codes -- Printed Copy: A03 Microfiche: A01

This report was prepared as an account of work sponsored by an agency of the United States Government. Neither the United States Government nor any agency thereof, nor any of their employees, makes any warranty, express or implied, or assumes any legal liability or responsibility for the accuracy, completeness, or usefulness of any information, apparatus, product, or process disclosed, or represents that its uses would not infringe privately owned rights. Reference herein to any specific commercial product, process, or service by trade name, trademark, manufacturer, or otherwise, does not necessarily constitute or imply its endorsement, recommendation, or favoring by the United States Government or any agency thereof. The views and opinions of authors expressed herein do not necessarily state or reflect those of the United States Government or any agency thereof.

RESEARCH AND DEVELOPMENT OF A  
HIGH EFFICIENCY GAS-FIRED WATER HEATER

Volume 1 - FINAL REPORT SUMMARY

MAY 1980

Prepared By:

Andrew D. Vasilakis  
John F. Pearson  
Dr. Joseph Gerstmann

ADVANCED MECHANICAL TECHNOLOGY, INC.  
141 California Street  
Newton, Massachusetts 02158

Prepared under Subcontract 7381 for the

Oak Ridge National Laboratory  
Oak Ridge, TN 37830  
Operated by  
Union Carbide Corporation  
for the  
U.S. Department of Energy  
Contract No. W-7405-eng-26

DISCLAIMER

This book was prepared as an account of work sponsored by an agency of the United States Government. Neither the United States Government nor any agency thereof, nor any of their employees, makes any warranty, express or implied, or assumes any legal liability or responsibility for the accuracy, completeness, or usefulness of any information, apparatus, product, or process disclosed, or represents that its use would not infringe privately owned rights. Reference herein to any specific commercial product, process, or service by trade name, trademark, manufacturer, or otherwise, does not necessarily constitute or imply its endorsement, recommendation, or favoring by the United States Government or any agency thereof. The views and opinions of authors expressed herein do not necessarily state or reflect those of the United States Government or any agency thereof.

## FOREWORD

This report is the first of two volumes which describes the work performed during Phase I on UCC-ND Subcontract 7381. In this contract, Advanced Mechanical Technology, Inc. (AMTI) is a subcontractor to Union Carbide Corporation - Nuclear Division to research, develop, and demonstrate a high efficiency gas-fired water heater. The water heater concept is a joint development of AMTI and Amtrol, Inc., who is a subcontractor to AMTI under this UCC-ND project. AMTI is responsible for the design and development tasks while Amtrol is responsible for the marketing and manufacturing tasks.

Volume 1, this report, is a summary of the task reports and describes the important results and conclusions. Volume 2, which contains all of the task reports, is bound separately and should be referred to if more detail is desired than contained in this volume. For the reader's convenience, the Table of Contents of Volume 2 is included with Volume 1.

## ACKNOWLEDGEMENTS

The authors would like to thank the technical management team from Union Carbide Corporation and in particular Dr. Donald J. Walukas, the project Technical Monitor, for both the managerial guidance and the valuable technical inputs he provided to the project.

For their continuing support of the project and their encouragement, we would like to thank Mr. Chester Kirk, Chairman of the Board at Amtrol and Mr. Kenneth Kirk, Chief Operating Officer. In addition, thanks are due to Mr. Phillip Barret, Director of Marketing at Amtrol for performing the market evaluation of the project water heater and to Mr. Robert Walker of Amtrol's Special Projects Staff for his helpful suggestions for improving manufacturability and for his valuable liaison work.

For his work in the laboratory, the authors would like to thank Mr. Robert Johnson. Without his help, the experimental program would not have proceeded as smoothly as it did.

VOLUME 1 - TABLE OF CONTENTS

<u>Section</u>	<u>Page</u>
ABSTRACT	vi
1. SCOPE OF WORK - PHASE I	1
2. RESULTS AND CONCLUSIONS	3
3. CONCEPT AND MARKET EVALUATION	7
3.1 CONCEPT EVALUATION	7
3.2 MARKETING EVALUATION	10
4. WATER HEATER DESIGN AND DEVELOPMENT	13
4.1 WATER HEATER DESIGN	13
4.2 PROTOTYPE WATER HEATER TESTING	17
4.3 SERVICE EFFICIENCY PROJECTION	21
5. MANUFACTURING PLAN AND FIELD TEST	24
5.1 PROTOTYPE MANUFACTURE AND TEST	24
5.2 MANUFACTURE AND FIELD TEST	24
6. REFERENCES	28



Volume 2 - Table of Contents  
Task 2 Report - Concept and Market Evaluation

<u>Section</u>	<u>Page</u>
Table of Contents	i
List of Figures and Tables	ii
1. Introduction and Summary	1-1
2. Concept Evaluation	2-1
2.1 Water Heater Performance - Basis for Evaluation	2-1
2.2 Cost/Performance Procedure	2-2
2.2.1 Performance Evaluation Method	2-2
2.2.2 Cost Evaluation Method	2-8
2.3 Component Economic/Performance Evaluations and Selections	2-11
2.3.1 Component Economic/Performance Evaluations	2-11
2.3.2 Option Selections	2-14
2.4 Water Heater Configurations - Economic/Performance Evaluations	2-17
2.5 Recommended Water Heater Configuration	2-22
3. Market Evaluation	3-1
3.1 Current Water Heater Market	3-1
3.1.1 Industry Characterization	3-1
3.1.2 Current Product Characteristics	3-3
3.1.3 Water Heater Market Characteristics	3-4
3.2 Amtrol Market Strategy	3-10
3.2.1 Initial Market Strategy	3-10
3.2.2 Long Range Trends	3-12
3.2.3 New Product Features	3-13
3.2.4 Recommended Specifications	3-19
4. References	4-1
<u>APPENDIX</u>	
A Water Heater Cost/Performance Model	A-1
B Computer Program	B-1
C Amtrol-Funded "Proof-of-Concept" Tests	C-1
D Water Heater Firing Rate	D-1

Volume 2 - Table of Contents  
Task 3.1 Report - Prototype Water Heater Design

<u>Section</u>	<u>Page</u>
Table of Contents	i
List of Figures	ii
List of Tables	ii
1. Introduction	1
2. Design Point Conditions	2
3. Component Designs	4
3.1 Heat Exchanger	4
3.2 Storage Tanks	10
3.3 Combustion System	13
3.3.1 Burner	15
3.3.2 Aspirator	15
3.3.3 Pilot	16
3.4 Sealed Combustion Stack	21
3.5 Control System	21
4. System Performance	25
4.1 Air Flow Characteristics	25
4.2 Service Efficiency	25
5. References	30

Volume 2 - Table of Contents

Task 3.2 Report - Prototype Water Heater Development

<u>Section</u>	<u>Page</u>
Table of Contents	i
List of Tables	ii
List of Figures	iii
1.0 Introduction	1
2.0 Water Heater Test Facility and Procedures	2
2.1 Test Facility	2
2.2 Water Heater Test Procedures	8
2.2.1 Recovery Efficiency Test Procedure	8
2.2.2 Standby Loss Test Procedure	9
2.2.3 Capacity Tests	10
3.0 Component Development and Testing	11
3.1 Aspirator Development	11
3.2 Flameholder (Burner) Development	20
3.3 Pilot Development	24
3.4 Storage Tank Description	26
3.5 Heat Exchanger Development	32
3.6 Exhaust System Development	35
3.7 Gas Control Valve, Flame Safety and Igniter	41
4.0 Pre-Prototype and Prototype System Tests	45
4.1 Pre-Prototype System Tests	45
4.2 Prototype Water Heater System Tests	53
5.0 Service Efficiency Projections and Emissions Test Results	65
5.1 Service Efficiency	65
5.2 Emission Test Results	70
6.0 References	73
Appendix - Project Test Procedure for Water Heaters	A1

Volume 2 - Table of Contents  
Task 4 Report - Field Test Plan

<u>Section</u>	<u>Page</u>
1.0 Introduction and Summary	1
2.0 Prototype Manufacture and Test	3
2.1 Prototype Construction	3
2.2 Design Evaluation and Refinement	3
2.3 Manufacturer's Evaluation	5
2.4 Endurance Testing	5
2.5 AGA Design Review	7
3.0 Production Version Manufacture and Field Test	10
3.1 Advanced Development	10
3.2 Pre-Production Design	17
3.3 Pre-Production Prototype Fabrication	18
3.4 Laboratory Efficiency and Field Testing	21
3.5 AGA Certification	25
3.6 Water Heater Evaluation	26
3.7 Dissemination of Field Test Results	27
4.0 References	28

## ABSTRACT

This report provides a summary of the work performed under Phase I of the project to design and develop a cost-effective high efficiency gas-fired water heater. The project goal was to attain a service efficiency of 70% (including the effect of exfiltration) and a service efficiency of 78% (excluding exfiltration) for a 75 GPD draw at a 90°F temperature rise, with a stored water to conditioned air temperature difference of 80°F. Based on concept evaluation, a non-powered natural draft water heater was chosen as the most cost-effective design to develop. The projected installed cost is \$374 compared to \$200 for a conventional unit. When the project water heater is compared to a conventional unit, it has a payback of 3.7 years and life cycle savings of \$350 to the consumer.

A prototype water heater was designed, constructed, and tested. When operated with sealed combustion, the unit has a service efficiency of 66.4% (including the effect of exfiltration) below a burner input of 32,000 Btu/hr. In the open combustion configuration, the unit operated at a measured efficiency of 66.4% Btu/hr (excluding exfiltration). This compares with a service efficiency of 51.3% for a conventional water heater and 61% for a conventional "high efficiency" unit capable of meeting ASHRAE 90-75. Operational tests showed the unit performed well with no evidence of "stacking" or hot spots. It met or exceeded all capacity or usage tests specified in the program test plan and met all emission goals. Future work will concentrate on designing, building, and testing preproduction units. It is anticipated that both sealed combustion and open draft models will be pursued.

## 1. SCOPE OF WORK - PHASE I

The overall objectives of Phase I are to finalize the technical approach to the high efficiency water heater and to develop the selected concept to the point that its technical and market feasibility can be assessed. Thereafter, a manufacturing and field test plan would be prepared and the Phase I results presented in a final report.

The detailed scope of work for Phase I is described below.

### Task 1 - Project Plan

Prepare a detailed project plan showing the allocation of financial and personnel resources, the technical approach, the timing of principal events, decision points and milestones.

### Task 2 - Concept and Market Evaluation

Perform the studies necessary to determine the marketability of the high efficiency gas-fired water heater in the residential sector. Performance characteristics of units which can be marketed will be identified and an economic tradeoff analysis will be performed. Problems which impede commercialization of high efficiency gas-fired water heaters will be identified along with solutions planned to overcome the problems. A set of design specifications will be developed.

### Task 3 - Design and Develop Prototype Water Heater

Specify the gas-fired water heater and perform the work necessary to develop, fabricate, and test a prototype unit which is optimized for the target market identified in Task 2. The unit will have a service efficiency of 70% based on the Test and Evaluation Specification included in the project plan.<sup>1</sup>

### Task 3 - Test and Evaluation Specifications

Service Efficiency (including exfiltration) - 70%

#### Test Conditions

Water Inlet Temperature - 60°F  
Water Outlet Temperature - 150°F  
Fuel - Natural Gas  
Hot Water Usage - 75 gallons/day  
Stored Water Temperature - 150°F

#### Exfiltration Losses

Heat Loss based on the amount of conditioned air lost due to the operation of the water heater evaluated at an average indoor/outdoor temperature differential of 30°F.

#### Minimum Water Heater Capacity at a Delivery Temp of 150°F

- (1) 2 GPM for 10 minutes
- (2) 40 gallons in 1 hour
- (3) 80 gallons in 4 hours

### Task 4 - Field Test Plan

This task consists of preparing the project plan for the production and field demonstration of the high efficiency gas-fired water heater. The plan should be adequate to obtain credible information on energy consumption and efficiency, reliability, maintenance, performance, safety, and cost.

### Task 5 - Phase I Report

Prepare a final report which will be published in two volumes. Volume 1 will contain a summary covering all important aspects of Phase I work. Volume 2 will contain all of the task reports and cover in more detail than Volume 1 the work performed in Phase I.

## 2. RESULTS AND CONCLUSIONS

The objective of this project is to design and develop a gas-fired water heater with a service efficiency of 70% for a draw rate of 75 gallons of water per day at a 90°F temperature rise and accounting for exfiltration losses. If exfiltration is excluded, the service efficiency goal is raised to 78% to account for this. Service efficiency is defined as daily useful hot water Btu output divided by the gas energy consumed.

The measured service efficiency of the engineering prototype (open combustion system) shown being tested in Figure 1 was 66.4% (with no accounting for exfiltration). Under the same conditions, a conventional water heater would have a service efficiency of 51.3% and a current "high efficiency" unit would have a service efficiency of 61%. The prototype fell short of the 78% goal by 11.4 points.

In regards to sealed combustion, the prototype configuration did not include this option. This was because the use of sealed combustion at firing rates above 30,000 Btu/hr was found difficult to achieve as described in Section 4. Consideration of the relative importance of sealed combustion led to its temporary shelving until satisfactory performance could be demonstrated. Thus, the prototype could have been developed with sealed combustion at a firing rate of about 30,000 Btu/hr in which case the service efficiency of the unit including exfiltration would be 66.4% compared to a project goal of 70% or 3.6 points short of the goal.

The high service efficiency is achieved by increasing the recovery rate of the water heater and decreasing the standby losses. One of the more significant achievements was that the recovery efficiency was increased to 82% for this unit while conventional units operate between 70 and 75%. This high recovery efficiency was attained without powered combustion and at a substantial firing rate of 40,000 Btu/hr. One complaint about conventional "high efficiency" units is that the higher recovery efficiencies are achieved in part by lowering the burner input to about 30,000 Btu/hr, resulting in a lower recovery rate than standard units. The project water heater has a firing rate of 40,000 Btu/hr, resolving one of the major complaints of current energy conserving water heaters -- inadequate hot water.



Water and  
Temperature  
Instrumentation

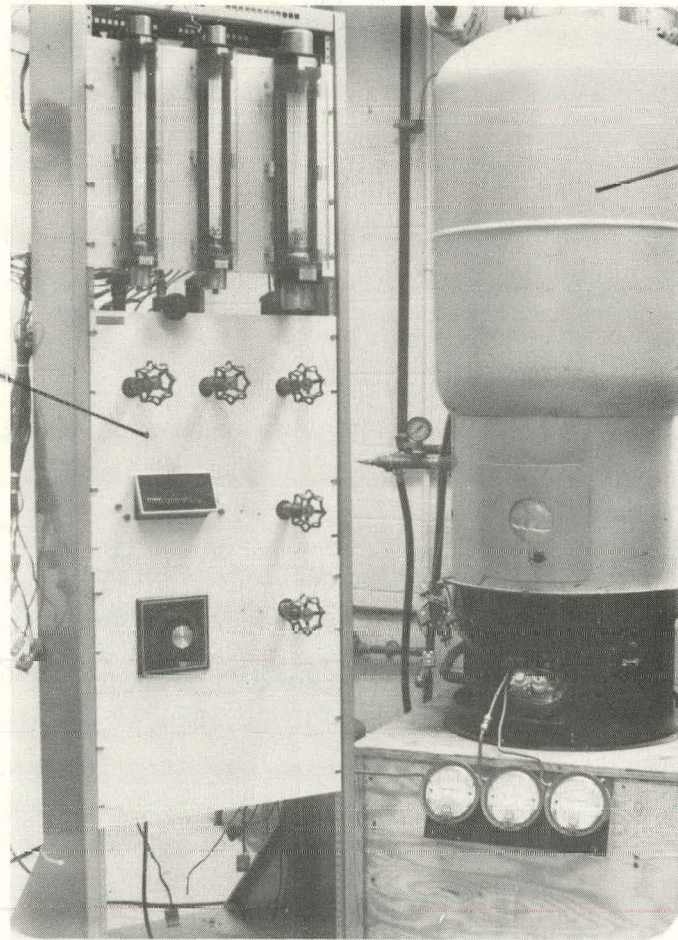

Prototype  
Water Heater  
Assembly

Figure 1. Prototype Water Heater Installed in Test Facility

Low standby losses were achieved by using an internally plastic-lined and insulated tank manufactured by Amtrol, Inc., the manufacturing subcontractor, and a low-input pilot designed for high recovery efficiency. A photograph of the tank is shown in Figure 2. The center flue design of conventional water heaters was eliminated, thus preventing the large loss of heat from stored hot water through the bare surface during the off-cycle. Another advantage of the tank over conventional units was the use of a durable plastic liner which should extend the useful life of the water heater to 15 years. Instead of a glass-lined tank which eventually leaks due to imperfections in the glass coating, this water heater uses a thick, one-piece plastic liner which does not require anodic protection and has an expected 15-year life in water service.

The installed cost of this unit is expected to be \$374 with sealed combustion or \$317 without it. The payback for the unit with sealed combustion is 3.7 years with life cycle savings of \$350 and 3 years with life cycle savings of \$275 on the unit without sealed combustion. These savings are based on an 11-year life and do not include the additional expected life due to the plastic lining.

The favorable technical and market evaluation results of Phase I have led to the decision to proceed to the Phase II manufacturing and field test, evaluation of 15 of the water heaters. During this phase, further refinements to the design will be made in order to raise its service efficiency further. Additionally, some effort during Phase II will be devoted to cost reduction improvements to enhance the commercialization potential.

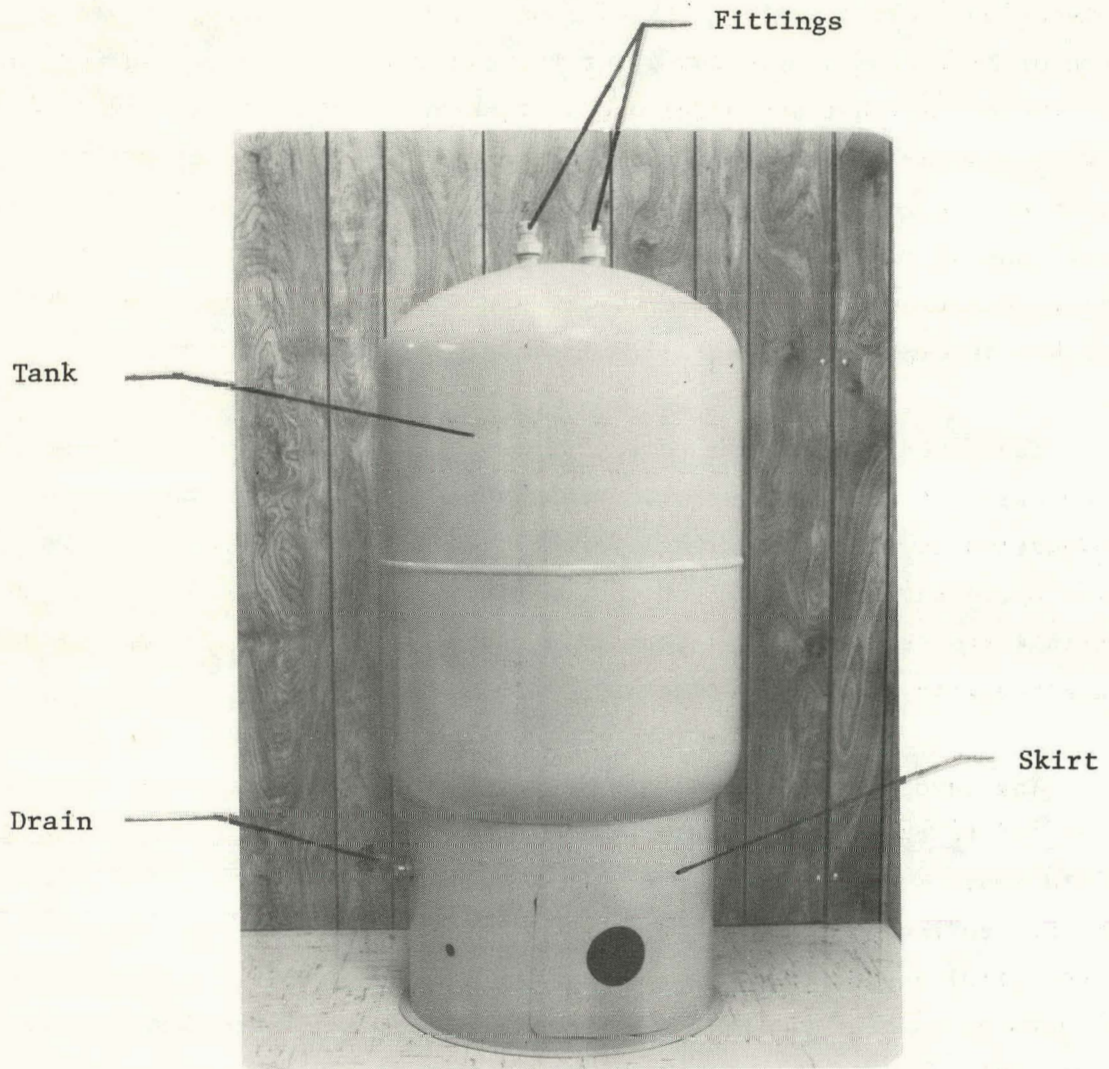

Figure 2. Prototype Storage Tank

### 3. CONCEPT AND MARKET EVALUATION

#### 3.1 CONCEPT EVALUATION

The object of this analysis is to compare water heater options both for cost and performance and to select the most cost effective design to meet the project goal. A computer program was written to analyze cost/performance tradeoffs.

The performance comparisons were conducted for a daily hot water draw of 75 gallons at a temperature of 150°F, and an inlet temperature of 60°F. An ambient temperature of 70°F was assumed. The exfiltration loss penalty assumed an average infiltration/exfiltration temperature differential of 30°F. Under these assumptions, the gas consumption of a conventional water heater was 109,000 Btu/day (service efficiency of 51.1%), excluding exfiltration, and 119,800 Btu/day (service efficiency of 46.5%), including the allowance for exfiltration. The cost of gas used in the analysis was \$3.00/MM Btu and an average water heater life was assumed to be 11 years.

Water heaters were separated into five subsystems: stack, including flue dampers and sealed combustion; storage tank, including plastic and glass linings, foam and fiberglass insulations; heat exchanger; burner; and pilot or other ignition means. Energy consumptions and costs were established for each design feature and simple paybacks and life-cycle costs for each were calculated using conventional water heater components for a baseline case. The result of the component optimization analysis was the water heater conceptual design described in Table 1.

Table 2 shows the installed cost and service efficiency of the selected design compared with (1) a conventional water heater, (2) a "high efficiency" conventional water heater incorporating increased flue baffling and/or reducing firing rate (75% energy recovery efficiency), reduced pilot consumption (300 Btu/hr) and 1 inch of added insulation, and (3) a forced combustion system using an intermittent ignition device (IID). These were compared both with and without sealed combustion. The

TABLE 1 - RECOMMENDED UNIT FOR DEVELOPMENT TASK

Component	Recommended Configuration	Performance Targets
1. Stack	Sealed Combustion	No Exfiltration
2. Tank	Insulated, Plastic Lined, Steel Tank	Volume - 40 Gallons Tank and Fitting Losses - 300 Btu/Hr
3. Heat Exchanger	Natural Circulation, Non-boiling, Bottom-fired Heat Exchanger	Stack Efficiency 84%
4. Pilot	Continuous Stratified Pilot	Firing Rate - 300 Btu/Hr, Recovery Efficiency - 81.3%
5. Burner	Natural Draft 100% Primary Air Burner	Firing Rate - 45,000 - 50,000 Btu/Hr
<ul style="list-style-type: none"> <li>● Unit Installed Cost - \$374</li> <li>● Service Efficiency (Including Exfiltration) - 72.5% <ul style="list-style-type: none"> <li>- 75 Gallon Daily Draw</li> <li>- 150°F Water Out; 60°F Water In</li> <li>- 70°F Ambient Temperature</li> </ul> </li> </ul>		

Table 2 Water Heater Combinations

<u>Gas-Fired Water Heater Type</u>	<u>Estimated Installed Costs For High Volume Production Units</u>	<u>Service Efficiency</u>	<u>Life-Cycle Savings</u>
	(\$)	(%)	
1. Conventional Glass-Lined Center Flue (Baseline)	\$205	46.5	-
2. Conventional "High Efficiency" Model			
-Standard Vent	285	55.5	155.
-Sealed Combustion	342	62.1	225.
3. Powered Combustion			
-Standard Vent	400	64.1	200.
-Sealed Combustion	458	73.1	270.
4. Project "High Efficiency" Model			
-Standard Vent	317	63.7	275
-Sealed Combustion	374	72.5	350.

"high efficiency" conventional unit has a service efficiency of 55.5% if sealed combustion is not used and 62.1% if the unit is supplied with sealed combustion. The paybacks for these conditions when compared to the baseline conventional water heater are 4 and 4.2 years, respectively.

Both the powered combustion and natural draft designs meet or exceed the project goal of a 70% service efficiency, including the effect of exfiltration. The powered combustion system is slightly more efficient than the natural draft system, but has an \$83 higher cost, resulting in lower life-cycle savings. Without sealed combustion, a savings of 38% relative to a conventional unit is possible, while with sealed combustion the savings are 57%. The natural draft system has a payback from 3-3.7 years, depending upon the use of sealed combustion, while powered combustion has a payback of approximately 5.5 years.

#### Recommended Water Heater Configuration

Based upon the features selected in the preceding evaluations, the concept shown in Table 1 was selected for development. Its salient features consist of: A high efficiency 100% primary air, naturally aspirated burner; an external, under-fired, natural circulation heat exchanger; a high efficiency standing pilot; a plastic-lined, insulated storage tank; and an external sealed combustion flue. This system has a projected service efficiency of 72.5%, and a payback period of slightly over 3.5 years. The life cycle savings for this unit based on an 11-year life are \$350.

### 3.2 MARKET EVALUATION

#### Current Water Heater Market

The current gas water heating market consists of a small number of manufacturers producing large quantities of similar units. It is a highly competitive cost conscious industry. Over 3 million gas heaters are sold annually and this number is expected to remain relatively constant for the next five years. Approximately 60% of water heater sales are used in the replacement market while the remaining 40% are sold for new installations.

Approximately 65 to 70% of all replacement water heaters are distributed through the plumbing trade. The consumer outlet in this case is the local plumbing contractor and his source is the plumbing or heating distributor who ultimately controls the brand or choice of water heater by the line he carries. The distributor usually chooses on a price basis, as there is little product differential among the major conventional heaters marketed today. The major retail chains (Sears, Montgomery Ward, etc) also account for a substantial share of replacement sales. Water heaters sold through this channel are private labeled and manufactured by a select few major heater manufacturers. Selection by the retail chain is made on lowest price and ability to meet demand. In new construction, builders will usually buy water heaters from the plumbing and heating distributor from whom he obtains his complete plumbing and heating materials.

Preliminary surveys have shown that the average consumer is concerned with: Inadequate hot water delivery (insufficient capacity); eventual failure of the unit; and to some extent, warranty protection. There is little indication that homeowners react to energy savings, pollution, or quality features when it comes to water heaters, as they are unaware of heater operating costs or performance characteristics related to these areas.

#### Amtrol Market Strategy

Since the marketing of a higher cost, high efficiency water heater will meet strong institutional barriers as the market is presently constituted, a somewhat different strategy is required to gain market penetration.

1. Education and Motivation of the Plumbing Trade -- This will be done using educational seminars based on new energy technology, ease of installation, greater customer satisfaction, and higher profit earnings. Wholesaler presentations will be made showing the profit motivation in carrying a second quality line. The objective here is to gain a supply on hand to meet the replacement sales.



2. Consumer Awareness and Indoctrination -- Amtrol will use its own publicity and also rely on local gas utility promotion to educate gas users as to the energy saving aspects and durability of the water heater. The objective is to create an overall marketing atmosphere of consumer awareness to support trade sales.
3. Presentations and Marketing to Selected Builders -- Joint promotions by Amtrol and gas companies to custom home builders as well as multi-family builders would be aimed at achieving a share of the new construction market.

Long range growth would be another aspect of Amtrol's strategy. Further expansion of market share will depend on current trends and their subsequent developments, such as the following.

1. Governmental legislation regarding energy use (such as HUD's mandating of sealed combustion), labeling, etc.
2. State and local emission regulations.
3. General public awareness of energy priorities through continuing government action.
4. Appearance and acceptance of other brands of efficient water heaters.

## 4. WATER HEATER DESIGN AND DEVELOPMENT

In this section, the prototype design of the water heater is described and the test results are presented and discussed. While two assemblies were tested, a pre-prototype (which used a non-prototype tank) and the prototype water heater, in this report only the prototype results will be presented. The pre-prototype water heater was used for initial development and for component testing and development which is described elsewhere.<sup>4</sup>

### 4.1 WATER HEATER DESIGN

Figure 3 is an assembly drawing of the prototype water heater with the component parts labeled. The burner, pilot, and control system are shown in more detail in Figure 4, and the heat exchanger in Figure 5.

Burner operation is initiated when the thermostat located in the tank senses a temperature below the cut-in setting. This causes the gas valve to open, admitting gas to the aspirator. The gas entrains all the air required for combustion, is mixed with the air in the aspirator, and is ignited at the surface of the burner screen by the pilot. The hot combustion products pass over the heat exchanger surfaces, heating the water and causing natural circulation of the water through the heat exchanger and back into the tank. When the tank reaches the thermostat cut-out setting, the gas valve is closed. Exhaust gases are collected in a shroud which surrounds the heat exchanger, and are directed into the stack.

Flame safety is accomplished in the conventional fashion by having the pilot heat a thermocouple. The thermocouple output keeps the gas solenoid valve open, allowing gas to enter the main gas valve which is controlled by the thermostat. If the pilot extinguishes, the solenoid valve closes and water heater operation ceases. The pilot is ignited using the piezoelectric ignition system which produces a high voltage spark between an electrode and the thermocouple sheath.

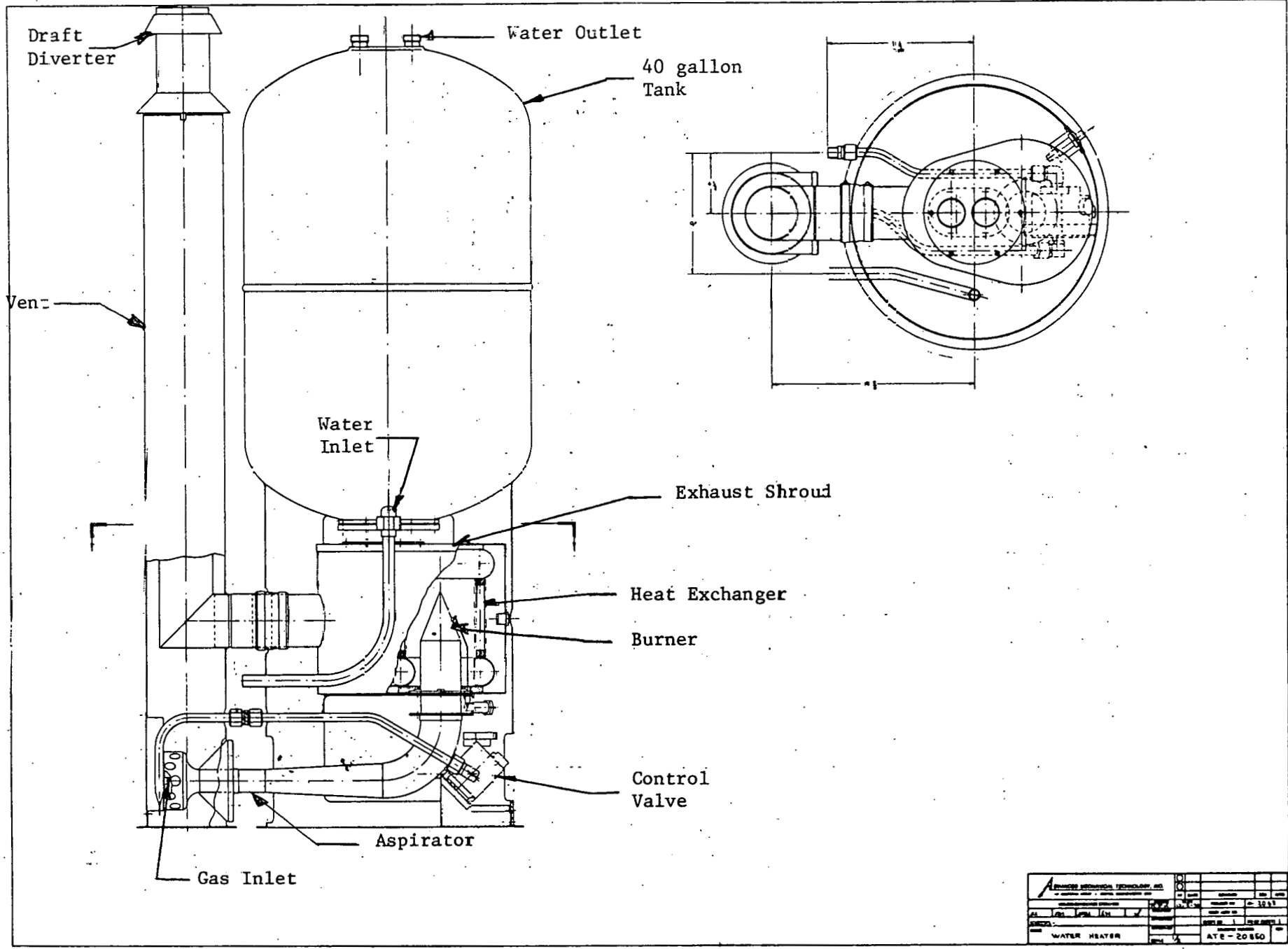

Figure 3. Prototype Water Heater Design

ADVANCED MECHANICAL TECHNOLOGY, INC.		DATE	BY	CHKD	APP'D
PROJECT	WATER HEATER	NO.	1	DATE	10-10-50
SCALE	AS SHOWN	BY	ATE	DATE	10-10-50
WATER HEATER		BY	ATE	DATE	10-10-50

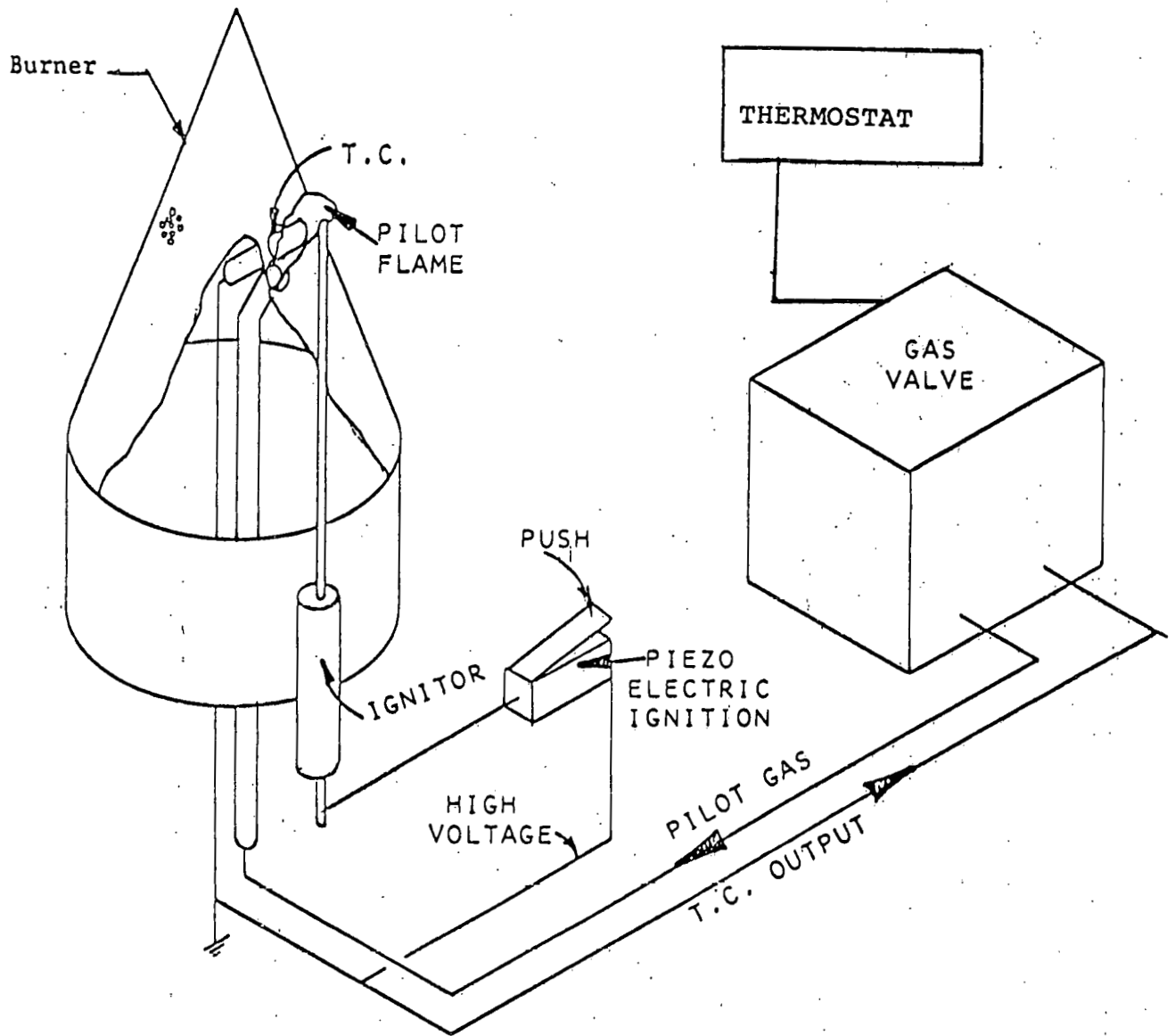

Figure 4. Pilot/Burner Configuration

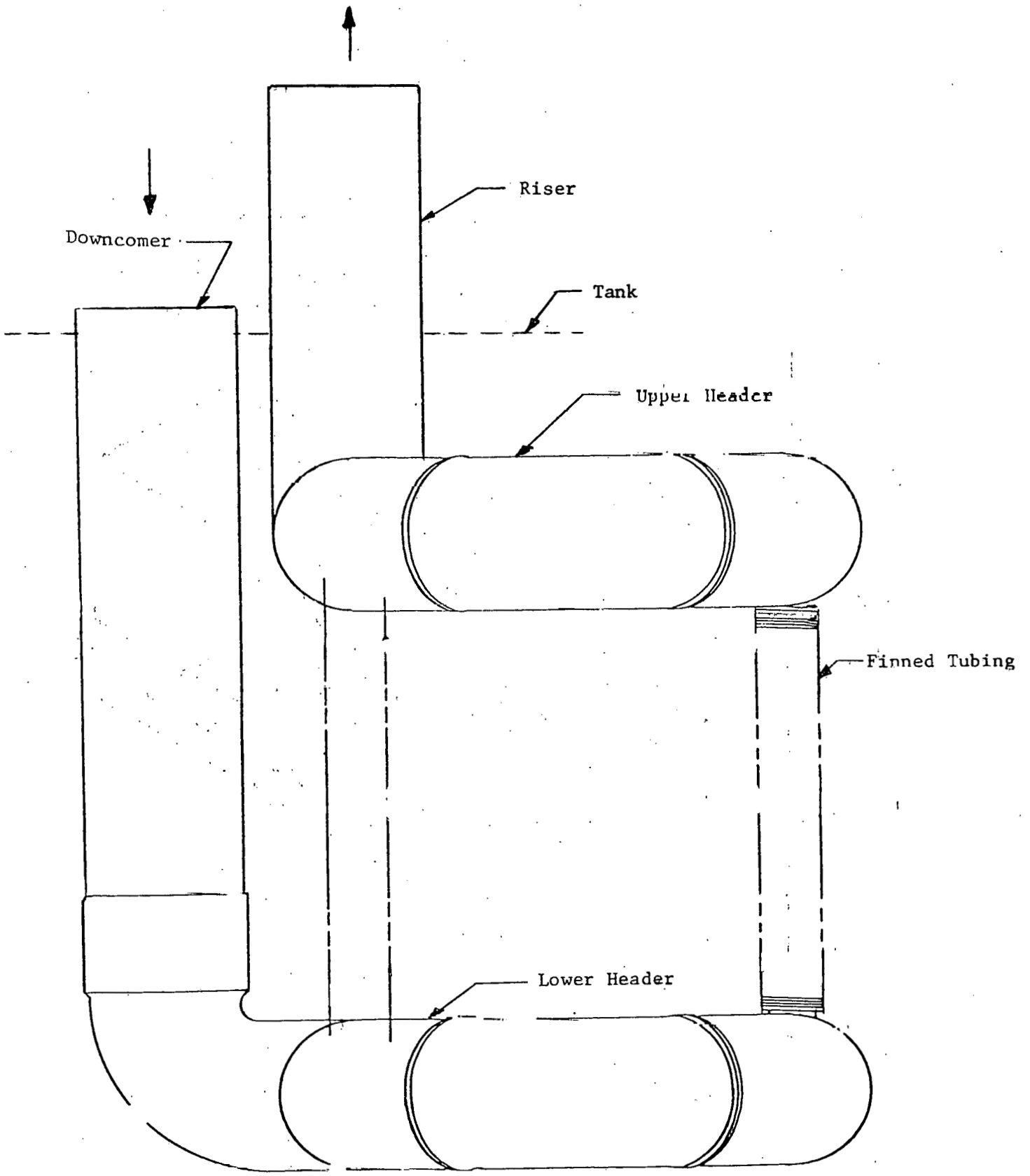

Figure 5. Heat Exchanger Configuration

## 4.2 PROTOTYPE WATER HEATER TESTING

The prototype water heater was tested in the test facility shown in Figure 6. The facility is capable of performing the DOE testing<sup>3</sup> for water heaters, as well as developmental and diagnostic testing. Three types of tests were performed on the prototype heater: (1) Recovery efficiency tests, (2) standby loss tests, and (3) capacity testing. The first two define the energy performance of the water heater while the latter defines the water heating capacity.

### Prototype Water Heater Recovery Efficiency Tests

Recovery efficiency was measured by heating a known volume of water through a 90°F temperature rise. This was determined using a probe capable of measuring the initial and final water temperature in six equal volume tank locations. The ratio of the heat absorbed by the water divided by the measured fuel consumed is the recovery efficiency.

The results of the recovery tests are shown in Table 3. These were all performed at a nominal firing rate of 40,000 Btu/hr. All the prototype tests were performed with a draft diverter (no sealed combustion). The stack temperatures shown in Table 3 are the values measured at the end of the recovery tests before burner operation stopped. Variables such as carbon monoxide and excess air vary somewhat during the test, so the ranges of these variables are shown.

These tests result in an average recovery efficiency of 82% versus the project goal of 81.5%. While these tests were performed without sealed combustion, the results should be the same with sealed combustion, based on the pre-prototype tests.<sup>4</sup> During the recovery tests, carbon monoxide and oxides of nitrogen emissions were also measured. The carbon monoxide emissions were typically one-quarter to one-half of the AGA code requirements (ANSIZ21.10-1), while oxides of nitrogen levels were one-half the standards adopted by the South Coast Air Quality Management District.<sup>5</sup>

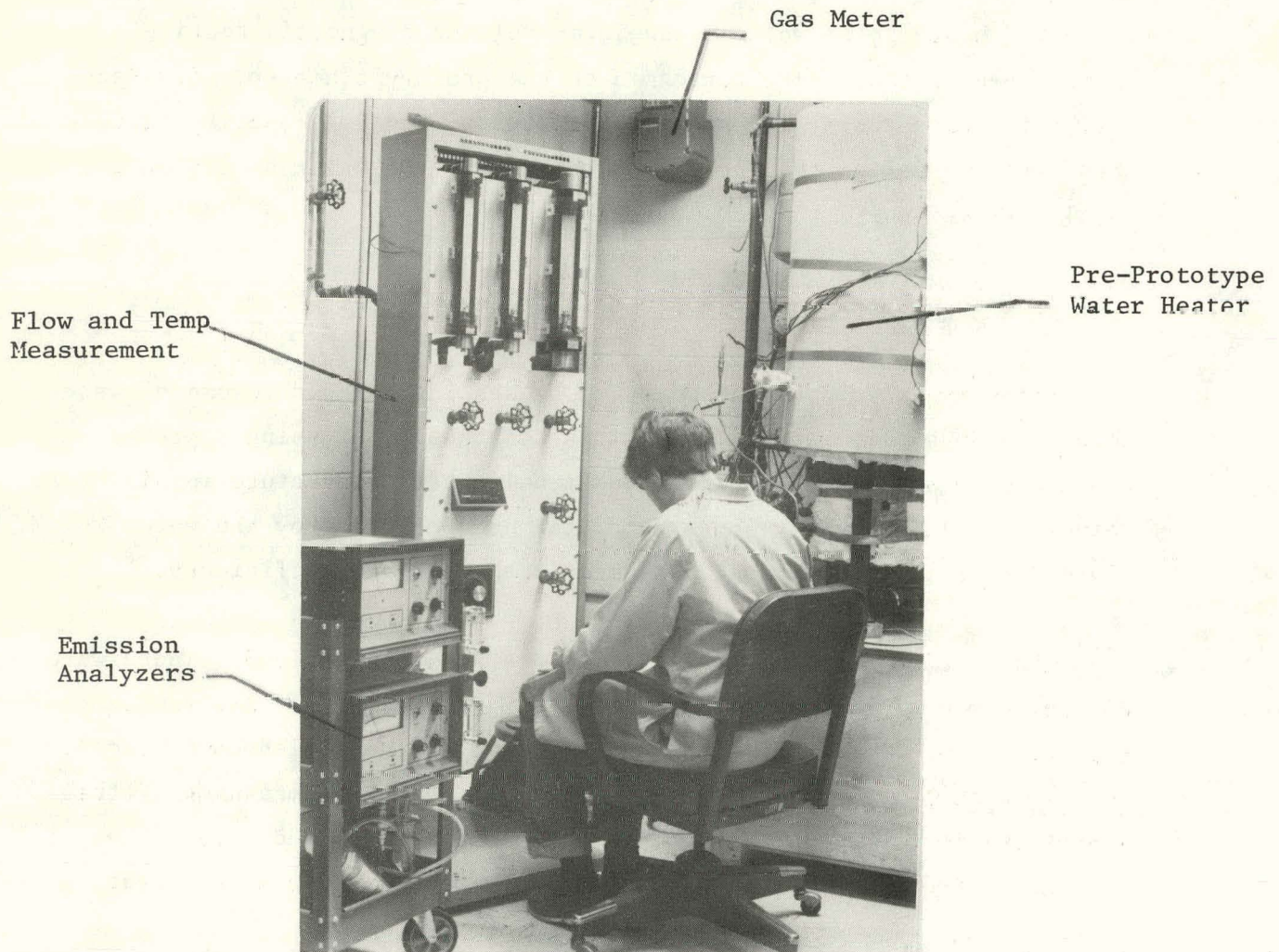

Figure 6. Pre-Prototype Water Heater Installed in Test Facility

Table 3: Prototype System Recovery Efficiency Tests

<u>Test No.</u>	<u>Firing Rate (Btu/hr)</u>	<u>Excess Air (%)</u>	<u>CO (PPM)</u>	<u>Stack Temp. (Max.-°F)</u>	<u>Water Temperature</u>		<u>Recovery Efficiency (%)</u>
					<u>Initial (°F)</u>	<u>Final (°F)</u>	
3D1024	42000	43-47	23-34	260	65	157	81
2D1024	41900	47-50	64-160	270	63	156	80
1R1112	42500	45-48	51-74	261	63	161	85
2R1112	42000	47-51	36-76	256	63	151	84
1R1114	40900	45-53	53-95	254	61	151	83



## Prototype Water Heater Standby Losses

Standby losses are defined as the ratio of the heat loss per hour to the heat content of the stored water relative to room temperature. The standby loss is made up of two parts: (1) The tank and fitting heat losses; and (2) the portion of the pilot input not utilized to heat stored water. The test consists of keeping the unit at its operating temperature for a 48-hour period without drawing water. Stored water and ambient temperatures are recorded every 15 minutes, and these together with the gas consumed are used to determine the standby loss (S-%/hr). Two tests were performed using the prototype tank shown in Figure 1 and the standby losses were found to be 2.7%/hr.

Section 4.3 relates the recovery efficiency and standby losses to the service efficiency.

## Capacity Tests

The test plan<sup>1</sup> for this project included water heater draw tests of 2 gallons per minute for at least 10 minutes, at least 40 gallons in one hour, at least 80 gallons in 4 hours, all the while maintaining a 150°F delivery temperature. In addition to these tests, the DOE one-hour recovery rating for the water heater was also performed.<sup>6</sup>

Following are the results for these tests:

1. 2 GPM at 150°F for 12 minutes
2. 40 gallons in one hour\*
3. 80 gallons in two hours\*
4. A one-hour recovery rating of 70.6 gallons

As can be seen, the prototype exceeded all of the capacity tests.

---

\* At the measured recovery rates, the unit is capable of 40 gph indefinitely.

### 4.3 SERVICE EFFICIENCY PROJECTIONS

The service efficiency is defined as the theoretical heat required for daily water heating divided by the total daily energy consumed.<sup>3</sup> The project goal is a service efficiency of 70% including the effect of exfiltration. The service efficiency is based on a 75-gallon daily draw, a water outlet temperature of 150°F, and a water inlet temperature of 60°F, and an ambient of 70°F.

Figure 7 shows the service efficiency plotted versus recovery efficiency for various standby losses. Shown in this plot is a revised project goal of 78% to account for exfiltration and the measured prototype result of 66.4%. For reference, a standard conventional water heater with a service efficiency of 51.3% and a conventional-type high efficiency unit with a service efficiency of 61% are shown. Since the prototype did not operate with a sealed combustion system, exfiltration is accounted for by increasing the project goal from 70% (with exfiltration) to 78% (without exfiltration). This increase in efficiency was based on a 9600 Btu/day penalty for exfiltration using a simple model<sup>2</sup> which was part of the program-plan requirement<sup>1</sup>. More recent work<sup>7</sup> indicates that this model may predict twice the actual exfiltration loss making a goal of 74% (without exfiltration) more realistic. In order to be consistent with previous analyses, however, the current model is used and the service efficiency goal excluding exfiltration is 78%. Further, while the unit meets the energy recovery goal, the standby losses of 2.7% per hour are above the project goal of 2% per hour. Thus, the deficiency in service efficiency of the prototype is due to higher standby losses than expected and the elimination of sealed combustion as a design feature.

Tests were also run with sealed combustion and the same 66.4% service efficiency was achieved including exfiltration effects. However, due to the flow resistance caused by the additional ducting, acceptable burner operation was limited to firing rates of about 30,000 Btu/hr and less. Consideration of the relative importance of high recovery rates versus sealed combustion led to the decision to accept the higher rating

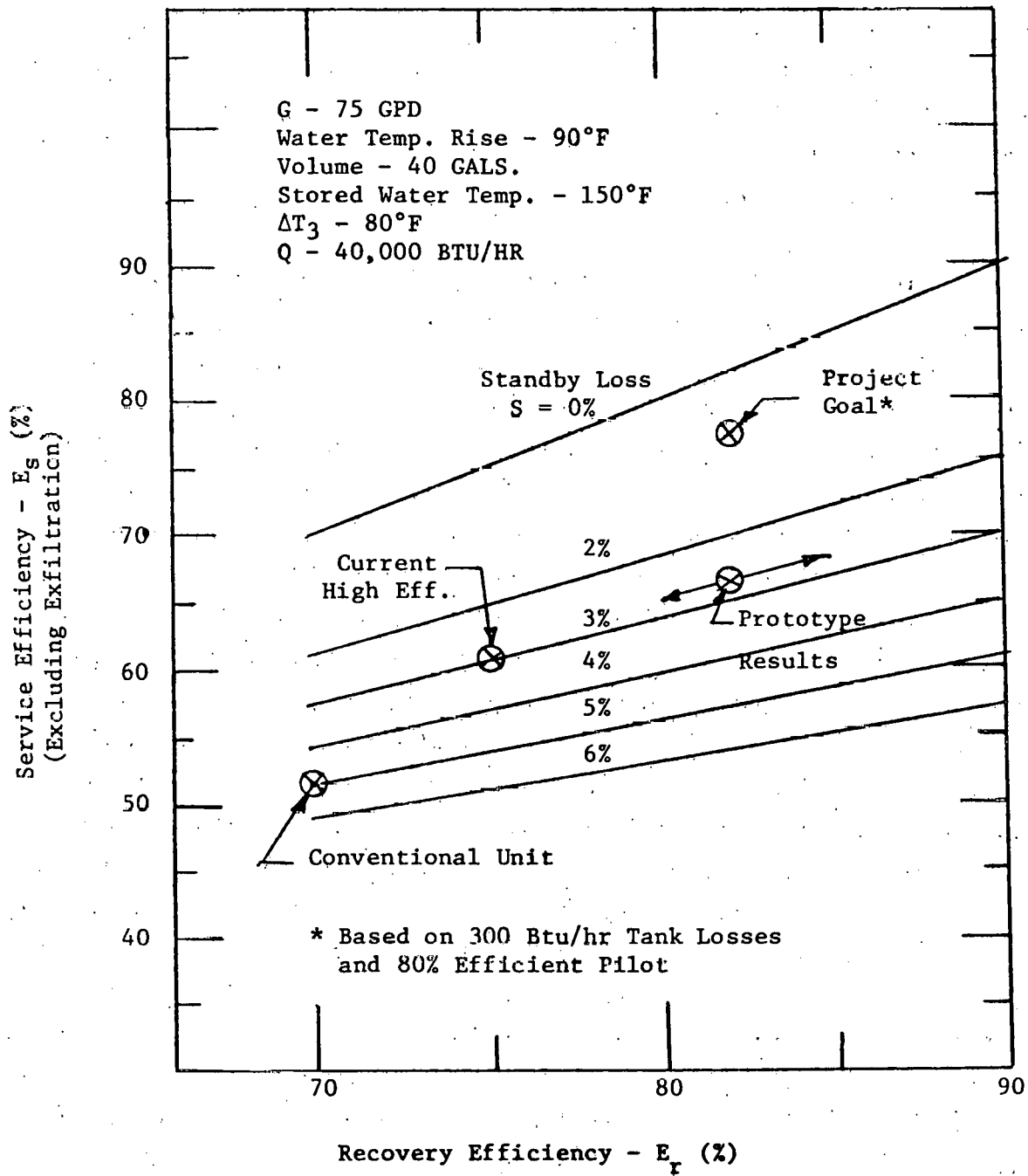

Figure 7. Service Efficiency Versus Recovery Efficiency at Various Standby Losses

and to temporarily shelve sealed combustion until it could meet the higher rating requirement. However, the option of sealed combustion with a lower recovery rate is still available when marketing considerations would dictate.

## 5. MANUFACTURING PLAN AND FIELD TEST

This section describes the highlights of the Phase II project plan. This plan is to perform a field demonstration of the unit developed in Phase I. The plan is to improve the unit from a manufacturing and operational standpoint, perform a production design, and manufacture pre-production prototypes. Laboratory efficiency tests will be used to establish unit performance. Fifteen units will then be field tested and at the end of these field tests, results will be disseminated. Figure 8 shows the timing planned for Phase II which is comprised of two main tasks: (1) Prototype Manufacture and Test, and (2) Manufacture and Field Tests.

### 5.1 PROTOTYPE MANUFACTURE AND TEST

The first task consists of the construction of ten prototypes by Amtrol, the manufacturing subcontractor. These units will basically be copies of the prototype unit developed in Phase I. Once the units are operational, they will be evaluated in several ways. Amtrol will use its units to familiarize its personnel with the design of the water heater, to evaluate its manufacturability, and to conduct independent tests.

One unit will be life tested. The object of this testing is to identify problems related to long-term operation of the unit. The water heater will be instrumented and set up to run at predetermined usage patterns simulating draw schedules which include showers, baths, dishwashing, and cloth washing. Also, a series of short draw tests will be performed to evaluate the "stacking" of the unit, if any. An accelerated life test will be run simulating one year of water heater operation.

Current plans are to submit one of the preliminary prototypes to AGA's research laboratory for early evaluation of the design.

### 5.2 MANUFACTURE AND FIELD TEST

The second task consists of refining the design of the prototype and the design, construction, laboratory testing and field testing of the

MODIFIED PROGRAM SCHEDULE - PHASE 2

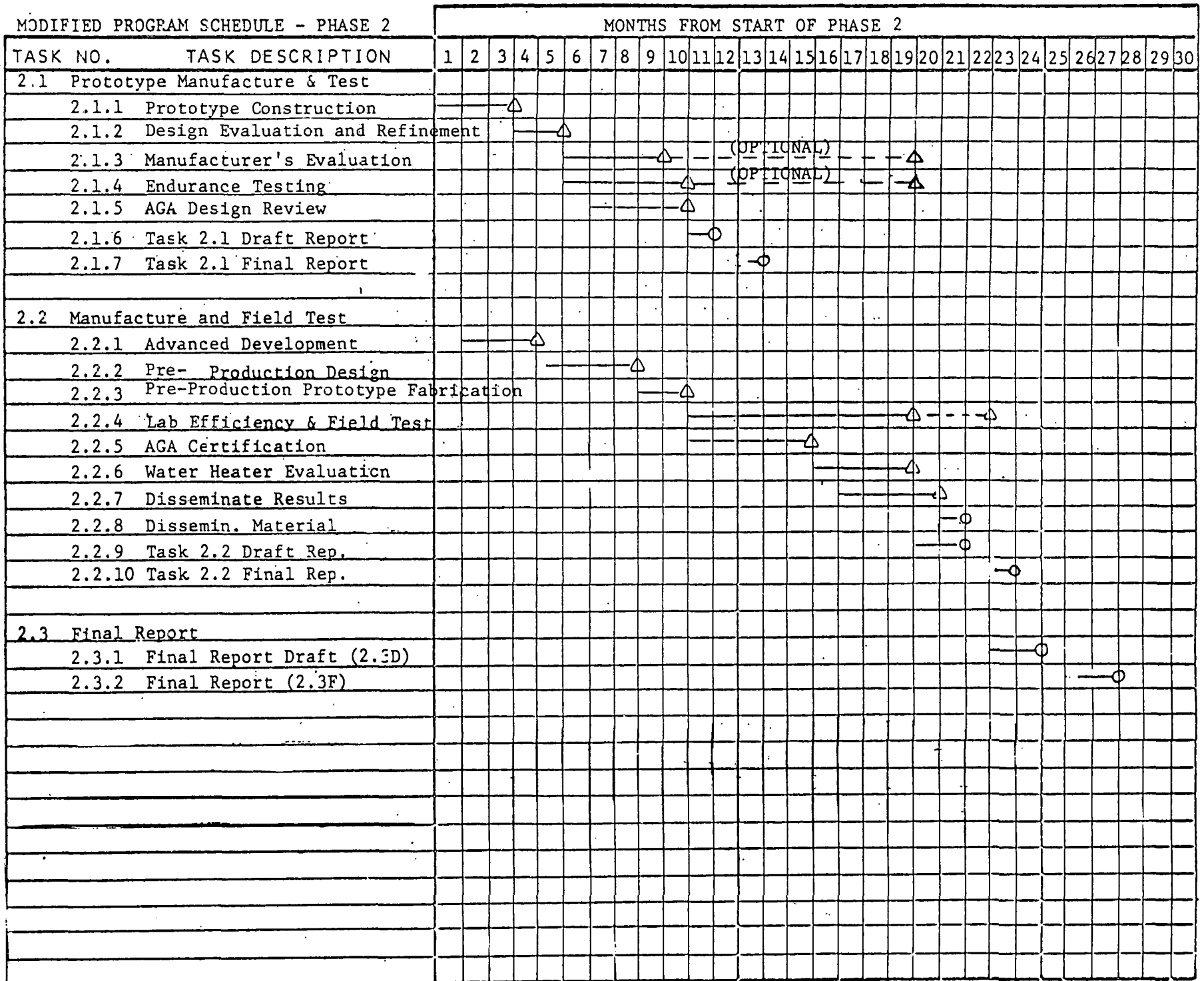

Figure 8. Phase II Program Schedule

production prototype. Prototype improvement will concentrate on improving the unit in four areas: 1) Maximizing the service efficiency, 2) improving reliability, 3) improving serviceability, and 4) lowering production costs. Initial work on this task will be performed using the original (Phase I) prototype. The advanced development work will continue on one of the ten prototype units when it becomes available.

The design of the production water heater will differ from that of the engineering prototype in two specific areas. The first area concerns the manufacturability of the unit. While previous designs had this as an ultimate goal, the emphasis was on performance. Input regarding manufacturability from Task 1 of Phase II will become available from Amtrol after they have built ten units. Thus, the unit can now be designed with the manufacturer's preferences in mind.

The second area of the design which will be addressed in this task is full compliance with the AGA code. After completion of the design, Amtrol will build thirty (30) serially produced units in the production configuration. This limited production run will not involve any large investment in "hard" tooling. Soft tooling or existing hard tooling will be utilized to approximate mass production techniques while minimizing tooling investments.

After production, laboratory efficiency and field tests will be performed. These will consist of measuring the performance of the water heater versus standard and high efficiency conventional units in the laboratory and in the field. The laboratory tests will consist of the DOE test for recovery efficiency and standby loss for two units of each type of water heater. These results will be used to map expected performance for each unit as a function of water usage, delivery temperature, and ambient temperature. This will be verified by running the unit over a demand schedule simulating various consumption patterns and delivery temperatures. Once this map is confirmed, it can be used to verify the field results and to predict savings to the consumer for various operating conditions.

The field testing of the water heater will be accomplished by installing the unit in about 20 test sites. In five of these test sites, the water heater's performance will be compared with high efficiency conventional water heaters which comply with ASHRAE 90-75. The remaining test sites will consist of a mix of units currently in use. Two sites, one having a standard conventional and one having a high efficiency unit, will be heavily instrumented with Btu meters, recorders and other instrumentation allowing a detailed experimental comparison of these test units with the project water heater. The remaining sites will have water and gas consumption measured on an alternating weekly basis to obtain a comparison of energy consumption versus conventional units under actual operating conditions. Participation of utilities will be enlisted in some of the field tests.

At the end of the field test, the results will be disseminated through as many channels as possible to create public awareness of the unit. This will serve to generate interest in the technology and in its introduction into the marketplace.

#### Further Work

The DOE-sponsored program is scheduled to end with Phase II. There is an option, however, to continue the field tests at a low level, monitoring basis if this appears worthwhile. Beyond this point, the intention is to proceed with commercialization, assuming favorable results from the project.



## 6. REFERENCES

1. "Program Plan for Research, Development and Demonstration of a High Efficiency Gas-fired Water Heater", AMTI, April 21, 1978.
2. "Research, Development and Demonstration of a High Efficiency Gas-Fired Water Heater," Volume 2, Concept and Market Evaluation, Task 2 Report, AMTI, April 1980.
3. "Energy Conservation Program for Appliances: Test Procedures for Water Heaters". Federal Register, Tuesday, October 4, 1977, Part III.
4. "Research, Development, and Demonstration of a High Efficiency Gas-Fired Water Heater," Volume 2, Water Heater Development, Task 3.2 Report, AMTI, April, 1980
5. South Coast Air Quality Management District, El Monte, CA. 91731, Rules and Regulations, Rule 1121 Control of Nitrogen Oxides from Residential-Type Natural Gas Fired Water Heaters, December 1, 1978.
6. "Energy Conservation Program for Appliances: Ammended Test Procedures for Water Heaters," Federal Register, May 9, 1979.
7. "An Assessment of Retrofit Automatic Vent Dampers for Residential Heating System", Arthur D. Little, Inc., November 1977.