

SLAC-PUB--3734

DE86 006952

34D  
SLAC - PUB - 3734  
July 1985  
(T/E)

**A RESEARCH PROGRAM WITH  
NO "MEASUREMENT PROBLEM"\***

②

**H. PIERRE NOYES**

*Stanford Linear Accelerator Center  
Stanford University, Stanford, California, 94305*

and

**CHRISTOFFER GEFWERT**

*Academy of Finland, Helsinki*

7.099645

and

**MICHAEL J. MANTHEY**

*Computer Science Department, Univ. of New Mexico*

Submitted to the Proc. New York Academy of Sciences  
"New Techniques and Ideas in Quantum Measurement Theory"  
New York City, 21-24 January, 1986

---

\* Work supported by the Department of Energy, contract DE - AC03 - 76SF00515.

CONF-860147--1

7-1560-1  
AT

## ABSTRACT

The "measurement problem" of contemporary physics is met by recognizing that the physicist *participates when constructing and [when] applying the theory* consisting of the formulated formal and measurement criteria (the expressions and rules) providing the necessary conditions which allow him to compute and measure facts, yet retains objectivity by requiring that these criteria, rules and facts be in corroborative equilibrium. We construct the particulate states of quantum physics by a recursive program which incorporates the non-determinism born of communication between asynchronous processes over a shared memory. Their quantum numbers and coupling constants arise from the construction via the *unique 4-level combinatorial hierarchy*. The construction defines indivisible quantum events with the requisite supraluminal correlations, yet does not allow supraluminal communication. Measurement criteria incorporate  $c$ ,  $\hbar$  and  $m_p$  or (not "and")  $G$ . The resulting theory is discrete throughout, contains no infinities, and, as far as we have developed it, is in agreement with quantum mechanical and cosmological fact.

## DISCLAIMER

This report was prepared as an account of work sponsored by an agency of the United States Government. Neither the United States Government nor any agency thereof, nor any of their employees, makes any warranty, express or implied, or assumes any legal liability or responsibility for the accuracy, completeness, or usefulness of any information, apparatus, product, or process disclosed, or represents that its use would not infringe privately owned rights. Reference herein to any specific commercial product, process, or service by trade name, trademark, manufacturer, or otherwise does not necessarily constitute or imply its endorsement, recommendation, or favoring by the United States Government or any agency thereof. The views and opinions of authors expressed herein do not necessarily state or reflect those of the United States Government or any agency thereof.

MASTER

20

## 1. INTRODUCTION

Quantum mechanics has to be adjoined to a "measurement theory" that has never been formulated in a satisfactory way; it is in the words of Wheeler<sup>[1]</sup> a *law without law*. For us "measurement" is part of any research program in physics; if we construct physics as a research program the "measurement problem" cannot be given a separate locus. We<sup>[2]</sup> first formulate what we mean by a *participatory* research program that specifies the criteria and the steps which can allow us to conclude that the program is complete. We present this schema in fig. 1. The implied philosophical position has been discussed by one of us (CG) elsewhere<sup>[3]</sup>. Although participation is involved in the *creation* of the program in virtue of the meaning-conferring acts of judgment entailed, the end result is *objective* in that, if successful, the program provides the same explanation of meaning for any participant when applied.

The technique we use to show the objectivity is to *code* the program and hence insure that it is computable. The program uses arbitrary numbers, in McGovern's sense, generated by the non-determinism born of communication between asynchronous processes over a shared memory.\* The basic entities in the program are ordered strings of the symbols "0,1" generated either by adding one arbitrary bit to each extant string or by discriminating between strings and adjoining a novel result to the bit string universe. The act of concatenating each extant string with an arbitrary bit is our representation of a "quantum event", changing the entire bit string universe whenever discrimination between extant strings fails to produce demonstrable novelty. Clearly such events are non-local, which is currently an experimentally implied requirement for quantum events. The problem is rather to show that in the articulation of the theory they do not allow supraluminal signalling.

---

\* D. McGovern uses "arbitrary" to mean "not due to any finite, locally specifiable algorithm"; since computer hardware is finite and attempts to be locally deterministic, he would replace Manthey's term "non-determinism" by the term "multi-determinism" (private communication).

The means used to connect the bit string universe to the practice of particle physics is to assume that

*any elementary event, under circumstances which it is the task of the experimental physicist to investigate, can lead to the firing of a counter.*

We call this the "counter paradigm". It allows us to connect the "quantum events" which occur in our computer program with laboratory counter firings in such a way as to provide our theory with both predictive power and corrigibility. We identify the three or four bit strings defining any quantum event as the basis states needed to construct a finite particle number relativistic (i.e. constrained by the "limiting velocity for signals") quantum scattering theory, including the conserved quantum numbers encountered in the "standard model" of quarks and leptons, and to make a start on computing the scale constants of modern physics.

## 2.CONSTRUCTING A BIT STRING UNIVERSE

The basic entities in the theory are ordered strings of the symbols "0", "1" [labeled below by  $a, b, \dots$ ] defined by  $S^a(N_U) = (\dots, b_n^a, \dots)_{N_U}$ , where  $b_n^a \in 0, 1$  and  $n \in [1, 2, \dots, N_U]$ . The strings combine by "XOR":  $S^a \oplus S^b \equiv (\dots, b_n^a + b_n^b, \dots)_{N_U}$  (for 0,1 bits) or by  $S^a \oplus S^b \equiv (\dots, (b_n^a - b_n^b)^2, \dots)_{N_U}$  (for 0,1 integers). This fruitful ambiguity allows us to refer to *either* operation as *discrimination*. The null string is called  $0_N \equiv (0, 0, \dots, 0)_N$ ,  $S^a \oplus S^a = 0_N$ ; the anti-null string is symbolized by  $1_N \equiv (1, 1, \dots, 1)_N$ , allowing us to define the "bar operation"  $\bar{S}^a(N) \equiv 1_N \oplus S^a(N)$  which interchanges "0"'s and "1" 's in a string.

We generate the strings according to the flow chart, fig. 2 . The program is initiated by the arbitrary choice of two distinct bits:  $R := 0$  or  $1$ ,  $\bar{R} = 1 \oplus R$ . Entering at *PICK*, we take  $S_1 := PICK$ ;  $S_2 := \bar{PICK}$ ;  $S_{12} := S_1 \oplus S_2$ . If  $S_{12} = 0_{N_U}$ , we recurse to picking  $S_2$  until we pass this test. We then ask if  $S_{12}$  is already in the universe. If it is not we adjoin it,  $U := U \cup S_{12}$ ,  $SU := SU + 1$ , and return to *PICK*. If  $S_{12}$  is already in the universe, we go to our third, and last, arbitrary operation called *TICK*. This simply adjoins a bit (via  $R$ ), arbitrarily chosen for each string, to the growing end of each string,  $U := U \parallel R$ ,  $N := N + 1$ ,

and returns us to *PICK*; here “||” denotes string concatenation. TICK results either from a *3-event* which guarantees that at that  $N_U$  the universe contains three strings constrained by  $S^a \oplus S^b \oplus S^c = 0_{N_U}$ , or a *4-event* constrained by  $S^a \oplus S^b \oplus S^c \oplus S^d = 0_{N_U}$ . That these are the only ways events happen in the bit string universe is demonstrated in fig. 3 .

Given two distinct (*linearly independent* or l.i.) non-null strings  $a, b$ , the set  $\{a, b, a \oplus b\}$  *closes* under discrimination. Observing that the singleton sets  $\{a\}$ ,  $\{b\}$  are closed, we see that two l.i. strings generate three *discriminately closed subsets* (DCsS's). Given a third l.i. string  $c$ , we can generate  $\{c\}$ ,  $\{b, c, b \oplus c\}$ ,  $\{c, a, c \oplus a\}$ , and  $\{a, b, c, a \oplus b, b \oplus c, c \oplus a, a \oplus b \oplus c\}$  as well. In fact, given  $j$  l.i. strings, we can generate  $2^j - 1$  DCsS's because this is the number of ways we can choose  $j$  distinct things one, two,... up to  $j$  at a time. This allows us to construct the combinatorial hierarchy<sup>14</sup> by generating the sequence  $(2 \Rightarrow 2^2 - 1 = 3), (3 \Rightarrow 2^3 - 1 = 7), (7 \Rightarrow 2^7 - 1 = 127), (127 \Rightarrow 2^{127} - 1 \simeq 1.7 \times 10^{38})$  mapped by the sequence  $(2 \Rightarrow 2^2 = 4), (4 \Rightarrow 4^2 = 16), (16 \Rightarrow 16^2 = 256), (256 \Rightarrow 256^2)$ . The process terminates because there are only  $256^2 = 65,536 = 6.5536 \times 10^4$  l.i. matrices available to map the fourth level, which are many too few to map the  $2^{127} - 1 = 1.7016... \times 10^{38}$  DCsS's of that level. This (unique) hierarchy is exhibited in Table I. The closure of the hierarchy allows us to divide the strings generated by the program into a finite initial segment (called the *label*) and a *growing remainder*. The labels close in some representation of the 4-level combinatorial hierarchy with exactly  $2^{127} + 136$  strings of fixed length, which are then used to label *address ensembles*, as is discussed in more detail in Ref. 2 and elsewhere.

Each event results in a TICK, which increases the complexity of the universe in an irreversible way. Our theory has an ordering parameter ( $N_U$ ) which is conceptually closer to the “time” in general relativistic cosmologies than to the “reversible” time of special relativity. The arbitrary elements in the algorithm that generates events preclude unique “retrodiction”, while the finite complexity parameters ( $SU, N_U$ ) prevent a combinatorial explosion in statistical retrodiction.

In this sense we have a *fixed* – though *only partially retrodictable* – *past* and a necessarily *unknown future* of finite, but arbitrarily increasing, complexity. Only structural characteristics of the system, rather than the bit strings used in computer simulations of pieces of our theory, are available for epistemological correlations with experience.

### 3. SCATTERING THEORY

Now that we have established the formal elements of the theory and the rules that allow us to compute formal facts, we must establish measurement criteria. This is done by relating the bit strings to the basis states of a relativistic, unitary and “crossing symmetric” quantum particle scattering theory, and deriving the “propagator” of that theory which connects events as some system within the universe evolves. The labels are used to define quantum numbers – symmetric between “particles” and “antiparticles” – that are conserved in connected events. The labeled address strings are interpreted as the velocities associated with these quantum numbers; by appropriate definition they are measured in units of the limiting velocity “ $c$ ”. Since quantum scattering theory associates quantum numbers with discrete conserved masses, and 3-momenta conserved in *evolving systems*, we also use the labeled address strings to define velocities (in units of the limiting velocity) which when multiplied by the appropriate discrete masses conserve 3-momentum in the discrete “3+1 space” that our events allow us to construct. Since the labels *close* these quantum numbers and masses  $m_p$  (which it will become the task of the theory to compute self-consistently) retain an invariant significance no matter how long the program runs, or how long and large the address string ensembles become.

The scattering theory on which we rely<sup>[4]</sup> starts from three distinguishable particles and a linear, unitary quantum dynamics based on relativistic three-particle Faddeev equations (which can be viewed as the summation of quantum events with appropriate statistical weights). The basic entities for “Yukawa coupling” are a particle, an antiparticle (number of particles minus number of antiparticle conserved), and a quantum (with zero particle quantum number) to

which this pair can coalesce, or which can disassociate into the pair; a quantum can be emitted or absorbed by a particle (or anti-particle) without changing the particle quantum number. Particles and quanta may carry other conserved quantum numbers allowing a definition of "anti-quanta", but there must always be one quantum state which carries only null quantum numbers. The "quantum" associated with that state is indistinguishable from its "anti-quantum".

We symbolize *any* string by  $S^w = [L^w(N_L), A^w(N)]$ . Our basic quantum number scheme for three linearly independent strings of bit length 4 is given in fig. 4, which meets the requirements set above. For any address string  $A^w(N)$ , the parameter  $k_w = \sum_{n=1}^N b_n^w$  allows us to define a signed rational fraction  $\beta_w$  for each address string by taking  $2k_w = N(1 + \beta_w)$ ; clearly  $\beta_w \in [-1, \frac{-(N-1)}{N}, \dots, \frac{(N-1)}{N}, +1]$ . Thus a 3-event initiates a state  $|N; k_a, k_b, k_c \rangle$  defined by four integers (referring to the address string, and at least two quantum numbers each for a, b, and c as discussed above) which specify three scalar rational fractions; these we interpret as velocities in units of the limiting velocity  $c$ .

Since the basic discriminations also define the strings  $A^{ab} = A^a \oplus A^b = A^c$  (a,b,c cyclic), and hence  $\beta_{ab} = \beta_c$  we conclude that each pair has the same velocity as the third, or spectator, system. The three velocities, three pair velocities, and three masses provide 9 of the 12 degrees of freedom of the three 4-vectors in a conventional description, while the remaining three cannot be specified without specific context because our construction has geometrical isotropy. We note that the "bar" operation  $\bar{S} = 1_{N_U} \oplus S$  reverses the sign of all velocities and all quantum numbers at the same time. In contrast, if we reverse only the velocities, the helicities do not reverse, showing that they are "pseudo-vectors". Our basis states have the characteristics needed for "crossing symmetry" and "CPT invariance".

To obtain the statistical connection between events, we start from our counter paradigm, and note that because of the macroscopic size of laboratory counters, there will always be some uncertainty  $\Delta\beta$  in measured velocities, reflected in our

integers  $k_0$  by  $\Delta k = \frac{1}{2} N \Delta \beta$ . Thus, if we start with some specified spread of events corresponding to laboratory boundary conditions, and tick away, the fraction of connected events we need consider diminishes in the manner illustrated in fig. 5. Since the "off shell propagator" of quantum scattering theory refers to the probability that two states which do not conserve energy will be connected we claim that we could, given more space, conclude from this calculation that the propagator is proportional to  $\frac{1}{(E - E' \mp i0^+)}$ .

Now that we have masses and the limiting velocity, and we know that from the hierarchy construction that the simplest unit of mass to use will be either the proton or the Planck mass, the only remaining dimensional constant to assign is the unit of action, or angular momentum. In previous treatments we have used the digital structure of the address strings and velocities to describe a drunkard's walk between events weighted by  $\frac{1}{2}(1 + \beta)$  with step length  $hc/E$ , which implies a coherence length  $h/p$  and hence the usual relativistic Debroglie phase and group velocities. Recent work on discrete topology by McGoveran<sup>(6)</sup> makes it likely that the digital structure also implies the usual relation  $\ell_x \ell_y = i\hbar \ell_z$  resulting from the "torsion" inherent in defining "distance" in a finite, digital space. Self-consistent definition of  $h$ ,  $\hbar$  and  $\pi$  along this route is a formal criterion we hope to meet in the near future.

#### 4. THE STANDARD MODEL

We interpret one dichotomous quantum number for each of the four levels as *helicity*. Since Level 1 has only two independent states, and these are coupled by the "bar" operation to the sign of the velocities which they label, we interpret these two basis states as *chiral* (two component) neutrinos. The next two quantum numbers (Level 2) allow for particle-antiparticle (or "charge") discrimination with helicity  $\pm \frac{1}{2}$  coupled to two  $\pm 1$  helicity states and the degenerate  $(0_4, 1_4)$  zero helicity state. We take these to be charged leptons coupled to a massless "spin 1" quantum, and the associated "coulomb" interaction. If we were constructing a "field theory" this would restrict us to the "physical" or "coulomb" gauge. In a finite particle number theory with exact unitarity this is not a restriction but



a conceptual necessity.

For Level 3 we concatenate a string of length 4 (interpreted as defining particle and helicity states  $q_1, q_2$ ) with a string defining the color octet. One way of getting the  $SU_3$  octet from our strings is given in Table 2 (or implied in Figure 4.). For color we could take red = (0001), anti-red = (1110); yellow = (0010), anti-yellow = (1101); blue = (1100), anti-blue = (0011). Then three colors or three anti-colors give the color singlet (1111), as do the appropriate combinations of color and anti-color. The three basis strings so constructed give us a colored quark and the associated gluons. Since  $\alpha \oplus \alpha \oplus \alpha \equiv \alpha$ , three colored quarks (or anti-quarks) add to give a color singlet and yield the spin and helicity states of a nucleon (anti-nucleon). Doubling the first four bits gives us a second flavor of quark, and a second nucleon when we form a color singlet using two of the first type and one of the second. Details will be presented elsewhere. Speculatively, since the scattering theory employed allows three states of the same mass to combine to single state of that mass, we can take both the quark and the nucleon mass to be the same; this would mean that quark structure would only appear at the 3 Gev level, which is desirable if nuclear physics is to continue to use mesons and nucleons as a first approximation. Level four gives us a combinatorial explosion of higher generations with the same structure, but only weakly coupled because of the large number of combinatorial possibilities.

The final step at this stage in the development of our theory is to set the mass ratio scale by invoking the Parker-Rhodes calculation<sup>[7]</sup>. As we have argued several times, our interpretation of quantum numbers and construction of 3 + 1 "space" allows us to take this over intact, and claim that  $m_p/m_e = \frac{137\pi}{\langle x(1-x) \rangle \langle 1/y \rangle}$ ;  $0 \leq x \leq 1$ ;  $0 \leq (1/y) \leq 1$  where  $x$  is the charge in units of  $e^2 = \hbar c/137$  and  $y$  is the radial distance from the center of symmetry limited from below by the minimal radial distance for a system at rest,  $\hbar/2m_p c$ . The statistical calculation is straightforward, and for three degrees of freedom gives  $\langle x(1-x) \rangle = (3/14)[1 + (2/7) + (2/7)^2]$  and  $\langle 1/y \rangle = 4/5$ . Hence  $m_p/m_e$  is predicted to be 1836.151497... in comparison with the accepted value of  $1836.1515 \pm 0.0005$ .

Although this result has been published and presented many times, we know of no published challenge to the calculation.

## 5. CONCLUSIONS

As we have said before<sup>[2]</sup>, "The idea of a theory as a *theory of constructions* is valid independent of the "information content" of the theory. In order for a research program to succeed, it must create complete understanding in the way we have developed the theory. Whatever "machinery" is formulated as a theory of constructions, the participator idea implicit in the theory structure is necessary in order to understand.

"In this paper we have proved that by starting from bit strings generated by *program universe* and labeled by the  $2^{127} + 136$  strings provided by any representation of the four-level *combinatorial hierarchy* one gets an S-matrix theory with the usual *C, P, T* properties, *CPT* and crossing invariance, manifest covariance and a candidate to replace quantum field theory by an *N*-particle scattering theory which will not be in conflict with practice for some sufficiently large finite *N*. Arbitrary ("random") choice and non-locality provide the supraluminal correlations experimentally demonstrated in EPR experiments without allowing supraluminal transmission of information. As is true for any quantum mechanical theory, ours stands because of the outcome of Aspect's and similar experiments, and would have to fall if these are rejected. We claim to have arrived at an objective quantum mechanics with all the needed properties."

## REFERENCES

1. Wheeler, J.A. 1983. *Law Without Law*. In J.A.Wheeler & W.H.Zurek, eds., *Quantum Theory and Measurement*, Princeton University Press: 182-213.
2. Noyes, H.P., C.Gefwert & M.J. Manthey. 1985. In *Proc., Symposium on the Foundations of Modern Physics*, Joensuu, Finland 16-20 June, (in press). See also H.P.Noyes, C.Gefwert and M.J.Manthey, "Toward a Constructive Physics", SLAC-PUB-3116 (rev. September 1983), and references therein.
3. Gefwert, C. 1983-84. *A Participant: the Metaphysical Subject*, SLAC-PUB-3277 (December, 1983) and *The Proposition-as-Rules Idea*, SLAC-PUB-3303, (March 1984), to be submitted to *Synthese. On The Logical Form of Primitive Recursive Functions*, SLAC-PUB-3334 (May 1984) and *On The Logical Form of Mathematical Language*, SLAC-PUB-3344 (May 1984), to be submitted to the *Journal of Philosophical Logic*.
4. Bastin, T. 1966. *Studia Philosophica Gandensia*, 4: 77.
5. Noyes, H.P., G. Pastrana & J.V.Lindesay. 1986. "A Manifestly Covariant Linear S-Matrix Dynamics Exhibiting Exact Unitarity and 'Crossing Symmetry'" (in preparation). H.P.Noyes & J.V.Lindesay, *Australian J. Phys.*, 38: 601 (1983). J.V.Lindesay, A.J.Markevich, H.P.Noyes & G.Pastrana, "A Self-Consistent, Poincaré Invariant, and Unitary Three-Particle Scattering Theory", SLAC-PUB-3661, May, 1985 and *Phys.Rev.D* (in press).
6. McGoveran, D. 1985. 7<sup>th</sup> Annual International Meeting of the *Alternative Natural Philosophy Association*, King's College, Cambridge, (unpublished) and private communication.
7. Parker-Rhodes, A.F. 1981. *The Theory of Indistinguishables*, Synthese Library, 150, Reidel, Dordrecht: 182-185.

**Table 1**  
The combinatorial hierarchy

	$\ell$	$B(\ell + 1) = H(\ell)$	$H(\ell) = 2^{B(\ell)} - 1$	$M(\ell + 1) = [M(\ell)]^2$	$C(\ell) = \sum_{j=0}^{\ell} H(j)$
hierarchy level	(0)	-	2	(2)	-
	1	2	3	4	3
	2	3	7	16	10
	3	7	127	256	137
	4	127	$2^{127} - 1$	$(256)^2$	$2^{127} - 1 + 137$

Level 5 cannot be constructed because  $M(4) < H(4)$

**Table 2**  
The SU3 octet for "I,U,V spin"

	$(b_1 b_2 b_3 b_4)$	$2I_x$	$2U_x$	$2V_x = 2(I_x + U_x)$
STRING:	1110	+1	+1	+2
	0010	-1	+2	+1
	1100	+2	-1	+1
	1111	0	0	0
	0000	0	0	0
	0011	-2	+1	-1
	1101	+1	-2	-1
	0001	-1	-1	-2

$$2I_x = b_1 + b_2 - b_3 - b_4$$

$$2U_x = -2b_1 + b_2 + 2b_3 - b_4$$

$$2V_x = -b_1 + 2b_2 + b_3 - 2b_4$$

## FIGURE CAPTIONS

1. The relation between knowledge of meaning and knowledge of fact, theory and measurement for a research program in physics.
2. Program Universe.
3. How events happen in *Program Universe*.
4. The quantum numbers for a string  $(b_1, b_2, b_3, b_4)$  defined by  $q_1 = b_1 - b_2 + b_3 - b_4$  and  $q_2 = b_1 + b_2 - b_3 - b_4$  plotted on a square mesh and  $2q_1, 2q_2, q_1 + q_2$  plotted on a hexagonal mesh.
5. The connection between the address strings in tick-separated events resulting from an initial uncertainty in velocity measurement: If  $k, k'$  represent two values of  $k$  allowed by the velocity uncertainty  $\Delta\beta$ , and  $\Delta k$  the corresponding integral uncertainty, the correlated probability of having both, normalized to unity when they are the same is  $f(k, k') = \frac{2\Delta k \mp (k' - k)}{2\Delta k \pm (k' - k)}$ , where the positive sign corresponds to  $k' > k$ . The correlated probability of finding two values  $k_T, k'_T$  after  $T$  ticks in an event with the same labels and same normalization is  $\frac{f(k_T, k'_T)}{f(k, k')}$ . This is 1 if  $k' = k$  and  $k'_T = k_T$ . But outside of this specific requirement, we can see that this ratio, written as

$$\frac{1 \pm \frac{2(\Delta k - \Delta k_T)}{(k' - k)} + \frac{4\Delta k \Delta k_T}{(k' - k)^2}}{1 \mp \frac{2(\Delta k - \Delta k_T)}{(k' - k)} + \frac{4\Delta k \Delta k_T}{(k' - k)^2}}$$

goes to  $0^\pm$  in the large number or sharp resolution limits, thus correlating the limits to an ordering depending on the sign of the velocity.

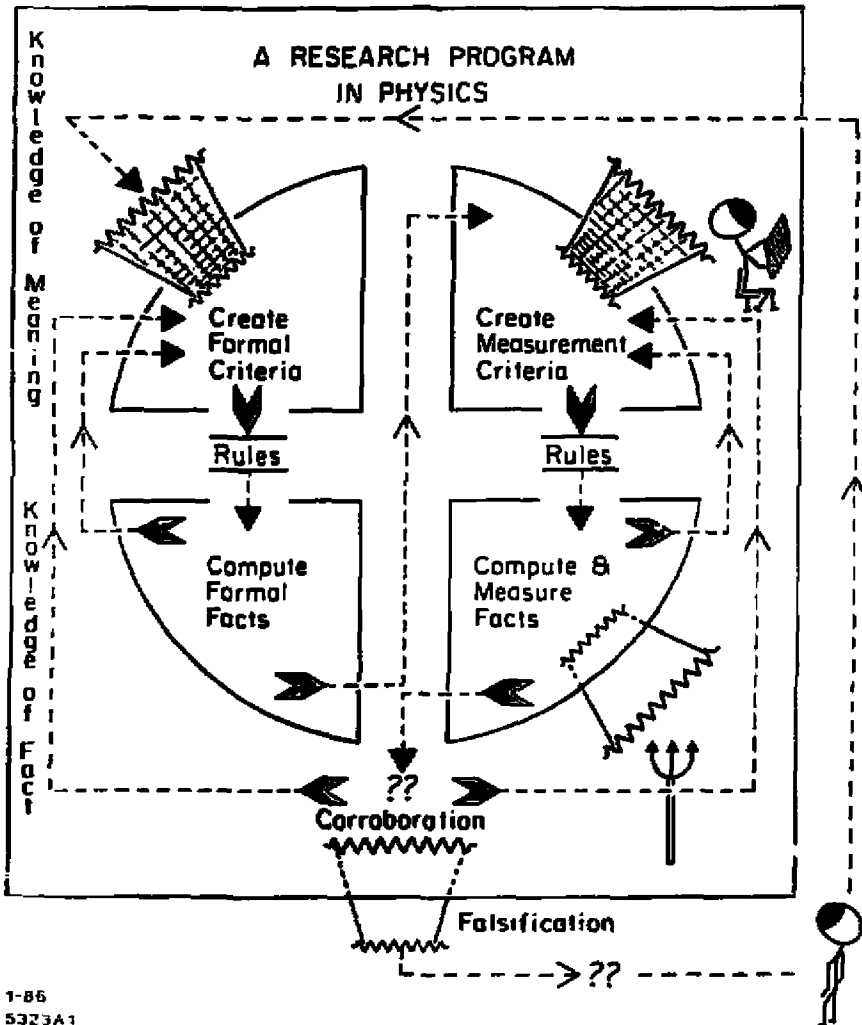

**Fig. 1**

## PROGRAM UNIVERSE

NO. STRINGS =  $SU$        $R \Rightarrow 0,1$  (FLIP BIT)  
 LENGTH =  $N_U$ ;      PICK := SOME  $U[i]$      $p = 1/SU$   
 ELEMENT  $U[i]$       TICK  $U := U \parallel R$   
 $i \in 1, 2, \dots, N$        $\bar{S} = I_N \oplus S$

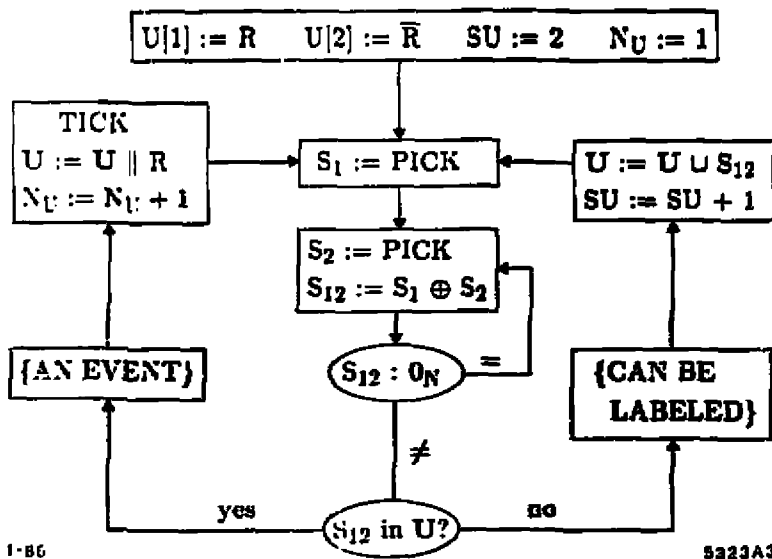

1-86

5223A3

Fig. 2



### 3-EVENTS

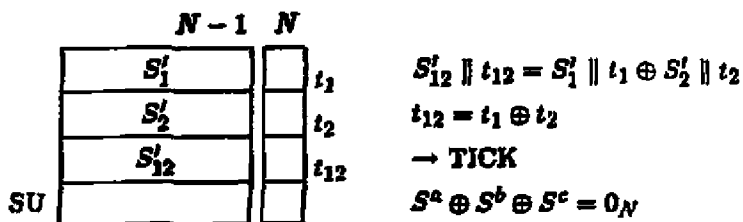

### 4-EVENTS

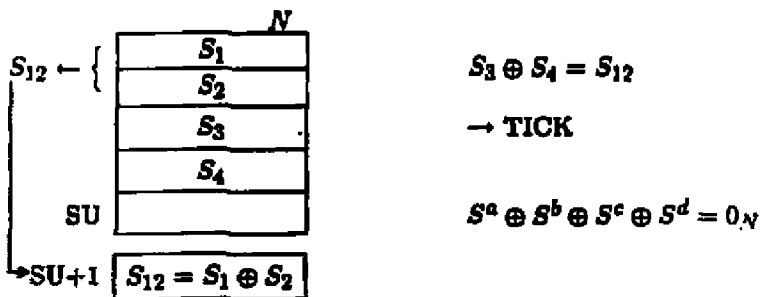

EACH TICK "RECORDS" A UNIQUE EVENT "SOMEWHERE"  
IN THE UNIVERSE

1-86  
5323A2

Fig. 3

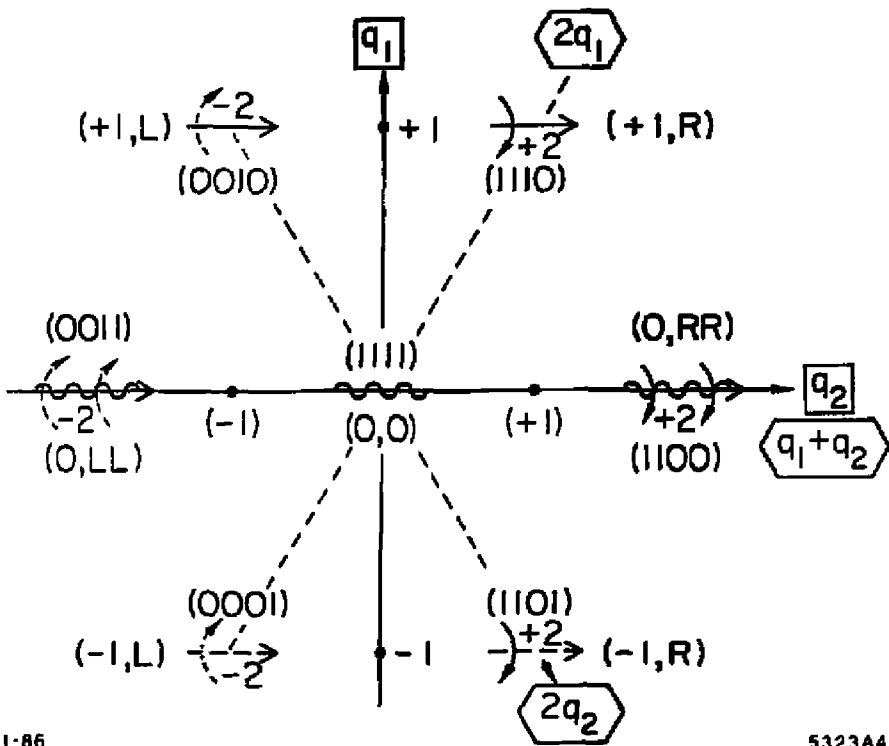

Fig. 4

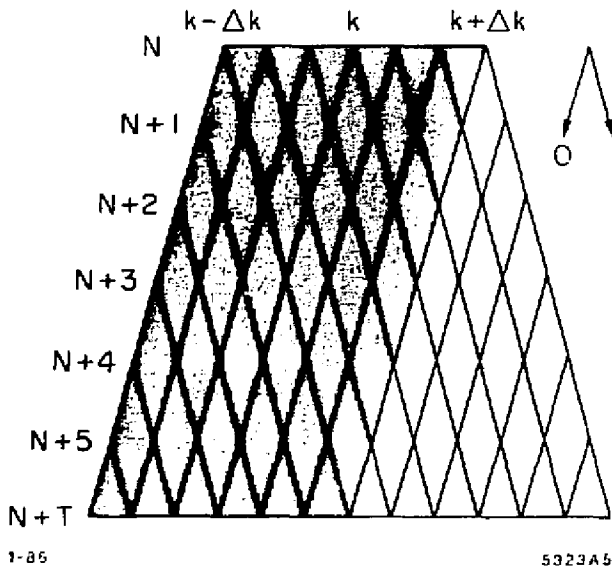

Fig. 5