

LA-UR -83-718

LA-UR--83-718

DE83 009961

CONF-830311--78

Los Alamos National Laboratory is operated by the University of California for the United States Department of Energy under contract W-7405-ENG-36

TITLE: IMAGESCOPE TO PHOTODIODE BEAM-PROFILE IMAGING SYSTEM

AUTHOR(S): D. D. Chamberlin, J. S. Hollabaugh, and C. J. Stump

SUBMITTED TO: 1983 Particle Accelerator Conference, Santa Fe, NM,
March 21-23, 1983.

DISCLAIMER

This report was prepared as an account of work sponsored by an agency of the United States Government. Neither the United States Government nor any agency thereof, nor any of their employees, makes any warranty, express or implied, or assumes any legal liability or responsibility for the accuracy, completeness, or usefulness of any information, apparatus, product, or process disclosed, or represents that its use would not infringe privately owned rights. Reference herein to any specific commercial product, process, or service by trade name, trademark, manufacturer, or otherwise does not necessarily constitute or imply its endorsement, recommendation, or favoring by the United States Government or any agency thereof. The views and opinions of authors expressed herein do not necessarily state or reflect those of the United States Government or any agency thereof.



By acceptance of this article, the publisher recognizes that the U S Government retains a nonexclusive, royalty-free license to publish or reproduce the published form of this contribution, or to allow others to do so, for U S Government purposes.

The Los Alamos National Laboratory requests that the publisher identify this article as work performed under the auspices of the U S Department of Energy

Los Alamos Los Alamos National Laboratory
Los Alamos, New Mexico 87545

EDB

IMAGESCOPE TO PHOTODIODE BEAM-PROFILE IMAGING SYSTEM*

D. D. Chamberlin,[†] J. S. Hollabaugh,^{††} and C. J. Stump, Jr.,^{††} AT-4, MS H821
Los Alamos National Laboratory, Los Alamos, NM 87545

Summary

Transverse beam-distribution measurements of high-current cw accelerators must be obtained from noninterceptive sensors. For the 100-mA H₂ or D beam of the Fusion Materials Irradiation Test (FMIT)^{1,2} accelerator, these transverse properties may be obtained by detecting the visible radiation resulting from beam interactions with residual gas. A system of mirrors, intensified TV cameras, digitizers, and tomographic reconstruction codes has been reported previously.^{3,4} This report describes a new technique for sensing and digitizing the light projected transversely from the beam of the FMIT accelerator at Los Alamos National Laboratory.

Figure 1 is a sketch of the main components of the Imagescope to photodiode beam-imaging system. An input lens focuses the beam-profile image onto a bundle of optical fibers that are spatially coherent from end to end. The output end gathers the fibers from the four input legs into a small double-row format. Thus, four different beam-profile images are transferred from this fiber-optic bundle (Imagescope) through a microchannel-plate (MCP) image intensifier with a format arranged so that two linear photodiode arrays (Reticons) receive the intensified images. The photodiode arrays have 512 elements each; thus, each beam profile has a 256-element resolution. An electronic package accepts the electric signal from the photodiodes, digitizes the contribution of each sensitive element, and transmits the digitized profile information over a fiber-optic data link to a memory unit accessible by the CAMAC data-acquisition and processing system. Details of this new beam-profile imaging and digitizing system are presented in the following sections.

Physical Arrangement

Figure 2 shows the prototypic assembly from input lens to digital transmitter. Each of the four input legs is 122 cm long with a bend radius of less than

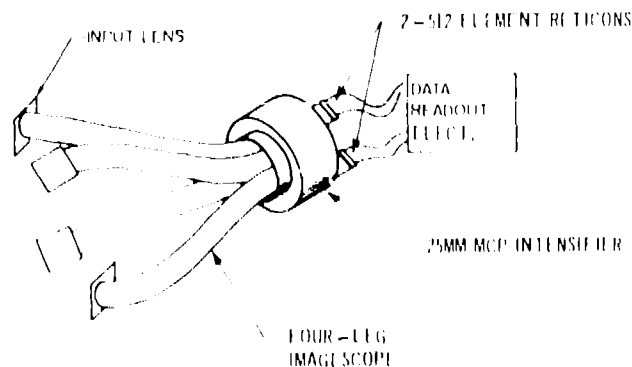

Fig. 1. Sketch of system components showing the coherent bundle fiber optic Imagescope, MCP image intensifier, linear photodiode arrays, and digitizing electronics package.

*Work supported by the US Department of Energy.

[†]Westinghouse-Hanford employee working at Los Alamos.

^{††}EG&G/Los Alamos Operations employee.

10 cm. The input ends are shown in various stages of assembly, from exposed fiber ends through lens coupler and inserted lens and on to a stripped lens mounted in the final beamline holder. The final holder is then mounted outside a narrow window on the beampipe within a 3.3-cm axial dimension. The inexpensive commercial lenses were disassembled to remove unnecessary materials and reduce the installed size. Custom-built lenses could allow still further reduction of the installation space requirements. The active area of the fiber bundle in each leg is 7 by 3 mm, with 6- μ m individual fiber diameters. The output end of the Imagescope gathers the images from the four legs into two rows of two images each with an active region of 14 by 3 mm for each row.

The output format of the Imagescope was chosen to fit in the active area of the 25-mm MCP intensifier. The MCP intensifier has a gain of up to 30 000, adjustable by the external voltage applied. The resolution of 25 line pairs/mm is the system's limiting resolution. The MCP intensifier is enclosed in the light-tight assembly between the output end of the Imagescope and the two photodiode arrays (Fig. 2). This assembly has provisions for aligning the photodiode arrays with the image regions on the intensifier's exit face. All these units use fiber-optic coupling for maximum efficiency in light transfer.

The linear photodiode arrays were chosen to maximize the active area and are referred to by their commercial name, Reticon. Each has an active area of 12.8 by 2.5 mm, separated into 512 elements along the long dimension. With two beam profiles imaged onto each Reticon, the resolution for each profile is 256 elements corresponding to a beam-view region of roughly 3 cm for this particular application. As seen in Fig. 2, the Reticons are attached to the read-out electronics with ribbon cables, although future versions will use sockets on the circuit boards for the Reticons, to reduce the unamplified signal transmission distance. The use of photodiodes to image a beam has been reported at Chalk River.⁵

The size of the electronic package is unnecessarily large for the version pictured in Fig. 2. Future versions will reduce the package size to roughly 10 by 15 by 20 cm. The Reticons may be cooled by installing them on thermoelectric cooling pads. Voltage control for the gain of the MCP intensifier is accomplished through this electronics package. The digitized output is transmitted over a fiber-optic data link. Note that powering this system with a small battery pack would imply complete electrical isolation with the attendant noise immunity. The overall system now being constructed will encompass four of these units to be placed at longitudinally separated positions on the beamline. This system then will provide input for tomographic reconstruction of the transverse beam-density distribution at any of the four positions or of the transverse emittance distribution in either horizontal or vertical planes.

Data Processing

The integration time for light input to the photodiode elements is selectable, with a tradeoff being made between dark current in the photodiodes, the gain voltage of the MCP intensifier, and the light stop of the input lens. Present usage has a 13-ms integration time and a well-stopped lens for increased depth of field. Figure 3 outlines the data flow from raw

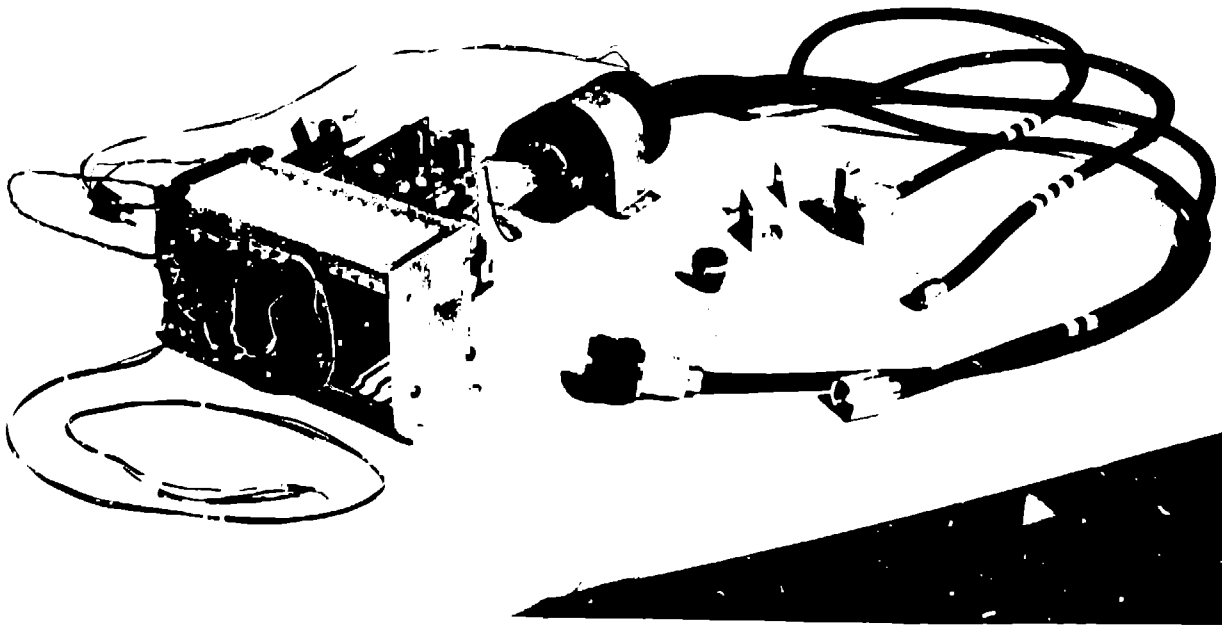

Fig. 2. Photograph of system components. The input ends (with varied lenses and holders) are in the right foreground with the Imagescope legs curving back to the light-tight enclosure of the MCP intensifier. Two ribbon cables emerge from the Reticons at the lower left of that enclosure and connect to the prototypic circuit boards of the readout and digitizing electronics package.

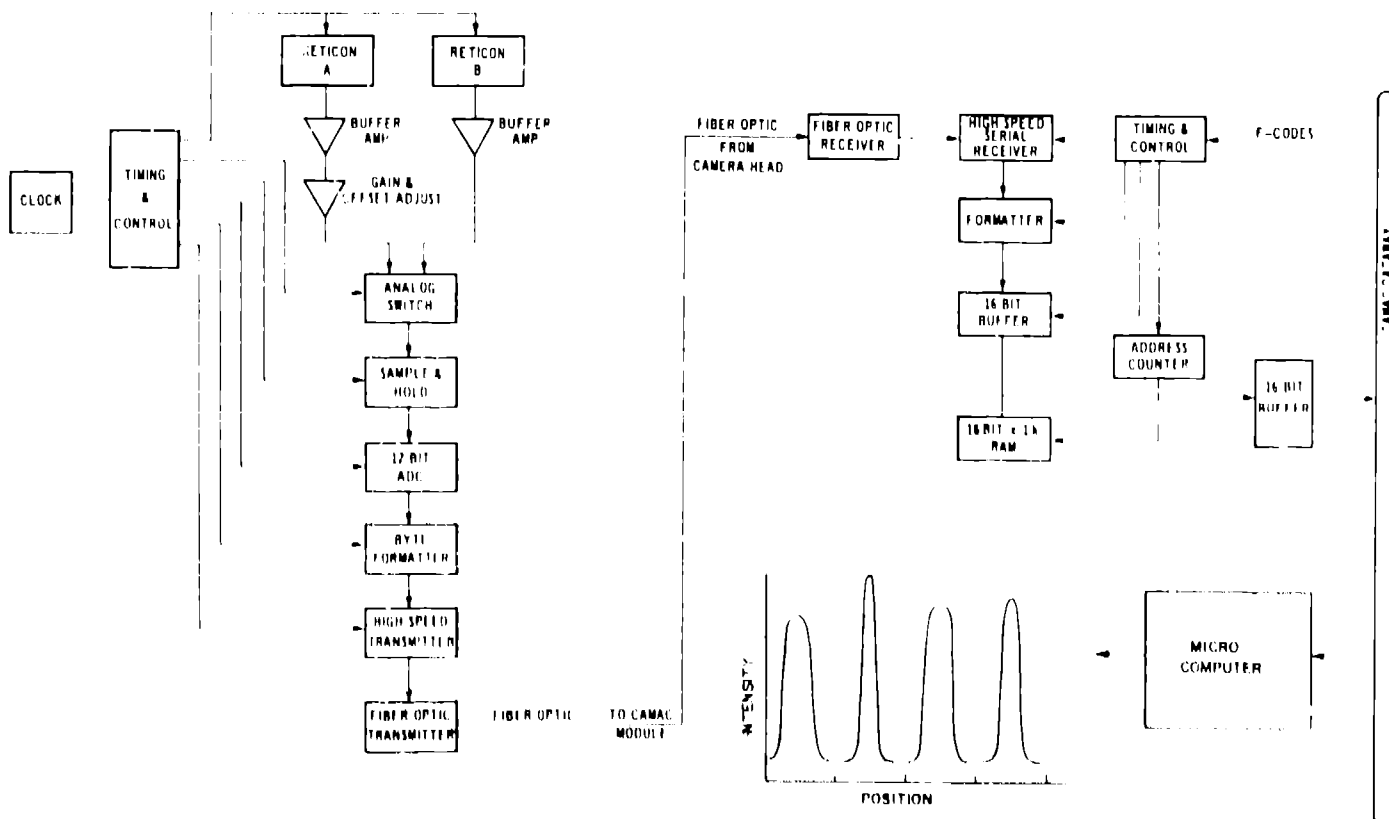

Fig. 3. Block diagram of the data flow and electronics. The left-hand section is physically located on the beamline and connects to the CAMAC module, drawn at the upper right, over the fiber optic link. Also shown is the CAMAC-based microcomputer and a sketch of the output data array.

photodiode current to profile display. Signals from the photodiodes are multiplexed into a 12-bit analogue-to-digital converter (ADC) and then transmitted in serial format over a fiber-optic transmission link. The receiver for this link is mounted in a CAMAC module with a 1024-element memory that is accessible from the CAMAC control system. The data are passed to the CAMAC-resident LSI 11/23 microcomputer that stores them on a magnetic disk. The profiles then may be plotted as shown in Fig. 3 or processed through the tomographic reconstruction coding to provide either transverse spatial or emittance distributions. Not shown in the figure is a digital-to-analogue converter (DAC) located in the CAMAC module that allows real-time presentation of the raw profiles on an oscilloscope as an aid to operator tuning of the beam.

Immediate plans for upgrading the system include mounting the Reticons on the read-out circuit board, adding a clock and microprocessor to the board, and providing an incoming fiber-optic link for control messages. The incoming link with the on-board processor will allow remote control of the MCP gain voltage, of the Reticon integration time, and of the sequencing of read-outs from the several Reticons of the completed system. These increased capabilities include timing of the Reticon light-integration period to correspond with the passage of a 10-ms beam pulse, an operating mode to be used for initial start up of the accelerator.

Conclusion

The system described here is now in use on the FMIT accelerator beamline at Los Alamos. It is working well and is sufficiently flexible in its application to be chosen for making new measurements of the

beam at new positions. The cost of the optical components appears to be steadily decreasing. The data quality is expected to be superior to that of the competing TV camera system. The noise immunity also is expected to be a preferred feature of this noninterceptive beam imaging system.

References

1. D. D. Armstrong, "The FMIT Accelerator," Los Alamos National Laboratory document LAUR-83-717 (1983) presented at the 1983 Particle Accelerator Conf.
2. R. A. Jameson, "High-Intensity Deuteron Linear Accelerator (FMIT)," Proc. 1979 Particle Accelerator Conf., San Francisco, CA, March 12-14, 1979, IEEE Trans. Nucl. Sci. 26, p. 2986 (1979).
3. D. D. Chamberlin, G. N. Minerbo, and C. T. Mottershead, "Noninterceptive Transverse Beam Measurements," Proc. 1981 Linear Accelerator Conf., Santa Fe, New Mexico, October 19-23, 1981, Los Alamos National Laboratory report LA-9234-C, p. 159 (February 1982).
4. D. D. Chamberlin, G. N. Minerbo, L. E. Teel, and J. D. Gilpatrick, "Noninterceptive Transverse Beam Diagnostics," Proc. 1981 Particle Accelerator Conf., Washington, DC, March 11-13, 1981, IEEE Trans. Nucl. Sci. 28, p. 2347 (1981).
5. J. S. Fraser, "Developments in Non-Destructive Beam Diagnostics," Proc. 1981 Particle Accelerator Conf., Washington, DC, March 11-13, 1981, IEEE Trans. Nucl. Sci. 28, p. 2137 (1981).

IMAGESCOPE TO PHOTODIODE BEAM-PROFILE IMAGING SYSTEM*

D. D. Chamberlin,[†] J. S. Hollabaugh,^{††} and C. J. Stump, Jr.,^{††} AT-4, MS H82?
Los Alamos National Laboratory, Los Alamos, NM 87545

Summary

Transverse beam-distribution measurements of high-current cw accelerators must be obtained from noninterceptive sensors. For the 100-mA H₂ or D beam of the Fusion Materials Irradiation Test (FMIT) accelerator, these transverse properties may be obtained by detecting the visible radiation resulting from beam interactions with residual gas. A system of mirrors, intensified TV cameras, digitizers, and tomographic reconstruction codes has been reported previously.^{1,2} This report describes a new technique for sensing and digitizing the light projected transversely from the beam of the FMIT accelerator at Los Alamos National Laboratory.

Figure 1 is a sketch of the main components of the Imagescope to photodiode beam-imaging system. An input lens focuses the beam-profile image onto a bundle of optical fibers that are spatially coherent from end to end. The output end gathers the fibers from the four input legs into a small double-row format. Thus, four different beam-profile images are transferred from this fiber-optic bundle (Imagescope) through a microchannel-plate (MCP) image intensifier with a format arranged so that two linear photodiode arrays (Reticons) receive the intensified images. The photodiode arrays have 512 elements each; thus, each beam profile has a 256-element resolution. An electronic package accepts the electric signal from the photodiodes, digitizes the contribution of each sensitive element, and transmits the digitized profile information over a fiber-optic data link to a memory unit accessible by the CAMAC data-acquisition and processing system. Details of this new beam-profile imaging and digitizing system are presented in the following sections.

Physical Arrangement

Figure 2 shows the prototypic assembly from input lens to digital transmitter. Each of the four input legs is 122 cm long with a bend radius of less than

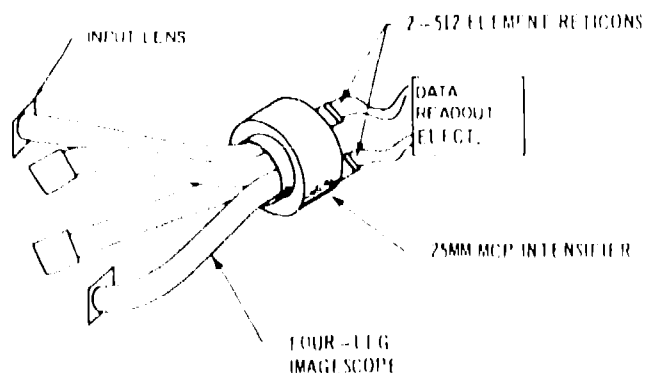

Fig. 1. Sketch of system components showing the coherent bundle fiber optic Imagescope, MCP image intensifier, linear photodiode arrays, and digitizing electronics package.

*Work supported by the US Department of Energy.
[†]Westinghouse-Hanford employee working at Los Alamos.
^{††}EG&G/Los Alamos Operations employee.

10 cm. The input ends are shown in various stages of assembly, from exposed fiber ends through lens coupler and inserted lens and on to a stripped lens mounted in the final beamline holder. The final holder is then mounted outside a narrow window on the beam pipe within a 3.3-cm axial dimension. The inexpensive commercial lenses were disassembled to remove unnecessary materials and reduce the installed size. Custom-built lenses could allow still further reduction of the installation space requirements. The active area of the fiber bundle in each leg is 7 by 3 mm, with 6- μ m individual fiber diameters. The output end of the Imagescope gathers the images from the four legs into two rows of two images each with an active region of 14 by 3 mm for each row.

The output format of the Imagescope was chosen to fit in the active area of the 25-mm MCP intensifier. The MCP intensifier has a gain of up to 30 000, adjustable by the external voltage applied. The resolution or 25 line pairs/mm is the system's limiting resolution. The MCP intensifier is enclosed in the light-tight assembly between the output end of the Imagescope and the two photodiode arrays (Fig. 2). This assembly has provisions for aligning the photodiode arrays with the image regions on the intensifier's exit face. All these units use fiber-optic coupling for maximum efficiency in light transfer.

The linear photodiode arrays were chosen to maximize the active area and are referred to by their commercial name, Reticon. Each has an active area of 12.8 by 2.5 mm, separated into 512 elements along the long dimension. With two beam profiles imaged onto each Reticon, the resolution for each profile is 256 elements corresponding to a beam-view region of roughly 3 cm for this particular application. As seen in Fig. 2, the Reticons are attached to the read-out electronics with ribbon cables, although future versions will use sockets on the circuit boards for the Reticons, to reduce the unamplified signal transmission distance. The use of photodiodes to image a beam has been reported at Chalk River.³

The size of the electronic package is unnecessarily large for the version pictured in Fig. 2. Future versions will reduce the package size to roughly 10 by 15 by 20 cm. The Reticons may be cooled by installing them on thermoelectric cooling pads. Voltage control for the gain of the MCP intensifier is accomplished through this electronics package. The digitized output is transmitted over a fiber-optic data link. Note that powering this system with a small battery pack would imply complete electrical isolation with the attendant noise immunity. The overall system now being constructed will encompass four of these units to be placed at longitudinally separated positions on the beamline. This system then will provide input for tomographic reconstruction of the transverse beam-density distribution at any of the four positions or of the transverse emittance distribution in either horizontal or vertical planes.

Data Processing

The integration time for light input to the photodiode elements is selectable, with a tradeoff being made between dark current in the photodiodes, the gain voltage of the MCP intensifier, and the light stop of the input lens. Present usage has a 13 ms integration time and a well-stopped lens for increased depth of field. Figure 3 outlines the data flow from raw