



# Lawrence Berkeley Laboratory

UNIVERSITY OF CALIFORNIA

## Engineering & Technical Services Division

Presented at the IEEE Particle Accelerator Conference,  
Washington, D.C., March 11-13, 1981

OPERATING EXPERIENCE WITH A NEW ACCELERATOR  
CONTROL SYSTEM BASED UPON MICROPROCESSORS

S. Magyary, H. Lancaster, F. Selph, M. Fahmie,  
C. Timossi, J. Glatz, A. Ritchie, J. Hinkson,  
R. Benjegerdes, and D. Brodzik

March 1981

### TWO-WEEK LOAN COPY

*This is a Library Circulating Copy  
which may be borrowed for two weeks.  
For a personal retention copy, call  
Tech. Info. Division, Ext. 6782*

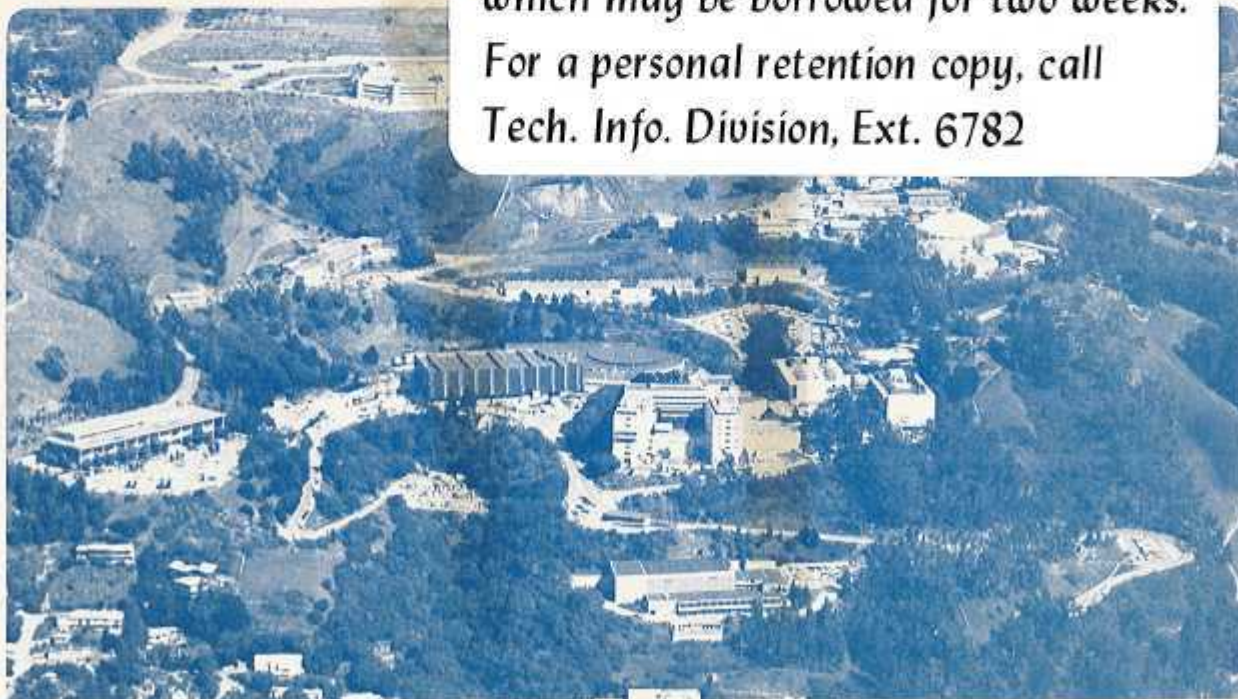

LBL-11724  
c.2

OPERATING EXPERIENCE WITH A NEW ACCELERATOR CONTROL SYSTEM BASED UPON MICROPROCESSORS\*

S. Magyary, H. Lancaster, F. Selph, K. Fahnie, L. Tinossi,  
 U. Glatz, A. Ritchie, J. Hinkson, R. Benjegerdes, D. Brodzik\*\*

Summary

This paper will describe the design and operating experience with a high performance control system tailored to the requirements of the SuperHILAC accelerator. A large number (20) of the latest 16-bit microcomputer boards are used in a parallel-distributed manner to get a high system bandwidth. Because of the high bandwidth, software costs and complexity are significantly reduced. The system by its very nature and design is easily upgraded and repaired. Dynamically assigned and labeled knobs, together with touch-panels, allow a flexible and efficient operator interface. An X-Y vector graphics system provides for display and labeling of real-time signals as well as general plotting functions. This control system allows attachment of a powerful auxiliary computer for scientific processing with access to accelerator parameters.

Introduction

When computer control was installed at the SuperHILAC six years ago, the two injectors were left with analog controls because the difficulty and expense of controlling them by computer seemed greater than the payoff. The special problems associated with digitizing equipment at high voltage includes the difficulty of obtaining noise-free data transmission and the ability to operate the injectors for tests during maintenance periods when the computer system is likely to be shut down as well. Satisfying the second requirement could only have been done with parallel analog controls, because the minicomputer-based system used a central data base computer which would not have been accessible during computer maintenance periods. When the third injector was being planned, we realized that advances in computer technology had opened a way to solve the problem with minimum cost, with different hardware, which would, however, be compatible with the existing SuperHILAC control system.

Thus the new third injector control system is entirely under computer control. The design philosophy and architecture of its microprocessor based control system have been described in previous papers.<sup>1,2</sup> Here it should be sufficient to enumerate briefly the features of this system which we believe are new, particularly those which distinguish it from the more common mini/microcomputer based control systems.

- o Use of a large number (~20) of microprocessor boards, each executing a simple task, or a series of simple tasks.
- o In each chassis there are several processors operating in parallel.
- o Use of a distributed data base in ROM (read only memory), so that local, stand-alone control of accelerator components can be readily done.
- o Use of fiber optics, permitting high bandwidth, noise-free data transmission.
- o Modular construction, which permits easy expansion of control points and of effective memory.
- o Update and repair is easily accomplished.
- o Use of a de facto industry standard card cage and bus--the multibus--which has a large number of suppliers of compatible components.

- o A loosely structured network concept, having the result that, since there is not a single central computer through which all data must flow, the system cannot develop a processing bottleneck which limits performance.
- o All programming is done with higher level languages.

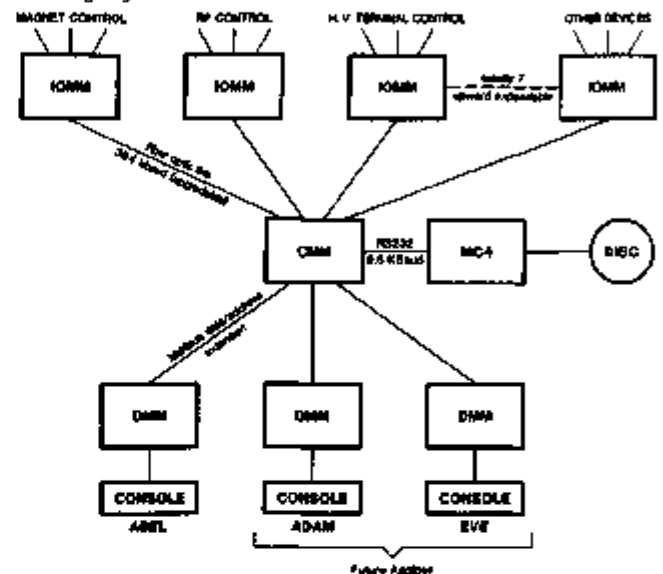

Fig. 1 Schematic of system architecture. \* 100-1200

Fig. 1 shows schematically the major components of the system. Each of the blocks represents a card cage with 8 or 12 slots, served by an internal multibus. The ROM modules interface to the accelerator equipment, collect and digitize data, and transmit control instructions to the hardware. These units contain the local data base in ROM. The CPU module serves as a collector for all data sent to and from the ROMs. It contains a copy of each ROM data base. There is one processor in this unit for each 8 ROMs; as more ROMs are added, additional boards are added as necessary to the CPU to handle the increased traffic. The DMA modules are used to service the operator consoles. Their access to the CPU database is by means of a multibus extension. This is a pair of boards designed in-house which extend the address and data lines from the CPU to the DMA. Several DMAs can be connected, in parallel, to the CPU. The three shown in fig. 1 correspond to three control stations at the SuperHILAC, one for each injector. At present, injectors 1 and 2 remain under analog control--we plan to convert them to digital control in the near future.

In the present paper we will focus primarily upon the DMA and associated operator console equipment.

The DMA

Fig. 2 shows schematically the computer boards used in the DMA at present--more can be added as needed. The alphanumeric display boards are used to write to the two CRTs. Output of the console touch screens is through the console computer board. A graphics computer board is used to support four vector graphic

\*This work was supported by the Director, Office of Energy Research, Office of High Energy and Nuclear Physics, Nuclear Science Division, U.S. Dept. of Energy under contract W-7405-ENG-48.  
 \*\*Lawrence Berkeley Laboratory, University of California, Berkeley, CA 94720.

displays. The operating computer is used to execute standard operating tasks, as well as to provide a link to a separate, powerful computer system which is used for a number of development activities. All of these computer boards have direct access to the data base in the DMM via the multibus extension.

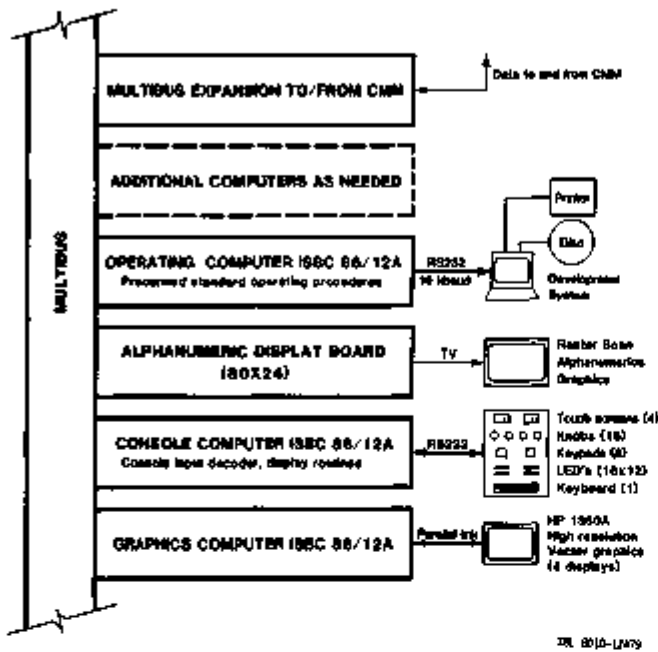

Fig. 2 Schematic of DMM configuration.

Operator Console

The portion of the console which is served by the microprocessor control system is shown in fig. 4. There are two control panels, each containing a CRT for displaying alphanumerics. These are overlaid with touch screens having a spatial resolution corresponding to the size of one character. Two 16-button pads to the right of each CRT allow entry of numbers and special commands. These input in parallel to the touch screens and give a little more flexibility for input. All commands could be given through the touch screens, but this would result in a great deal of wasteful paging back and forth in some cases.



Fig. 3 Photo of operator console.

SuperHILAC beams require frequent retuning, on the order of several times per week, because of changing circumstances. Consequently, knobs for operator use are important for this accelerator. Each CRT at the control station has 8 knobs, and each knob has a 12 character addressable LED for labeling the controlled device (see fig. 4). Alternatively, the device parameter value can be displayed in this space. Buttons located on the panel below the knobs are used to move a cursor on the CRT parameter list display, to scroll the list, to assign knobs to parameters, to change knob sensitivity, etc.

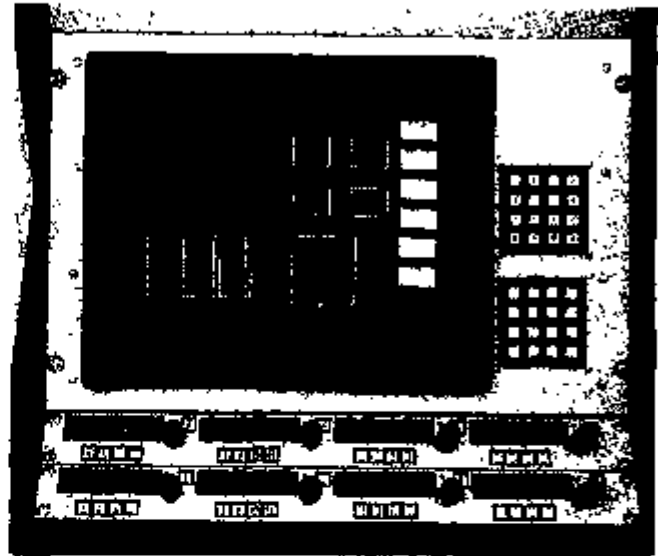

Fig. 4 Closeup of touch panel CRT with associated controls.

Four vector graphic display units are mounted at each console above the touch panels. These units, in addition to displaying graphs with alphanumerics, allow mixing of real-time analog signals with the digital plots. This can be thought of as an oscilloscope with labels under program control. These signals are added to the output of the graphics translator using a chopper technique (see fig. 5). The

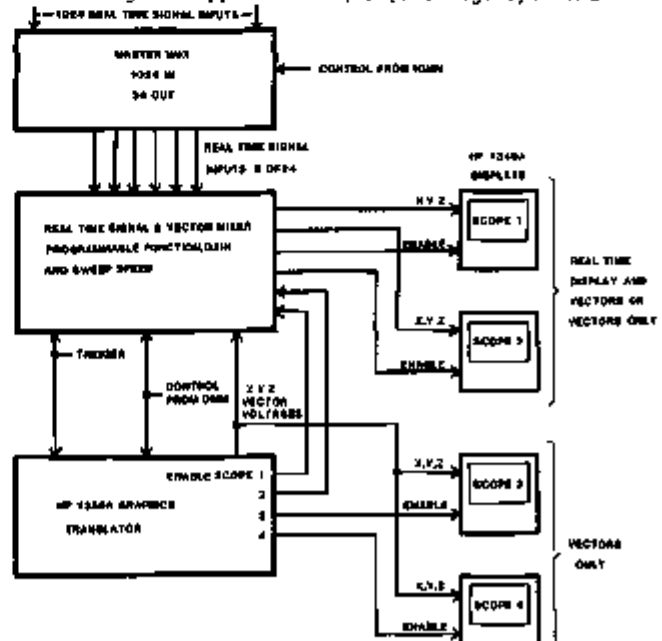

Fig. 5 Schematic of video mixing of analog signals with vector graphics translator output.

adder also provides for limited changing of the gain and time base. In fig. 6 the display is an example of the use of this analog capability to present three wave forms from the ion source extractor voltage, sputter current, and arc current.

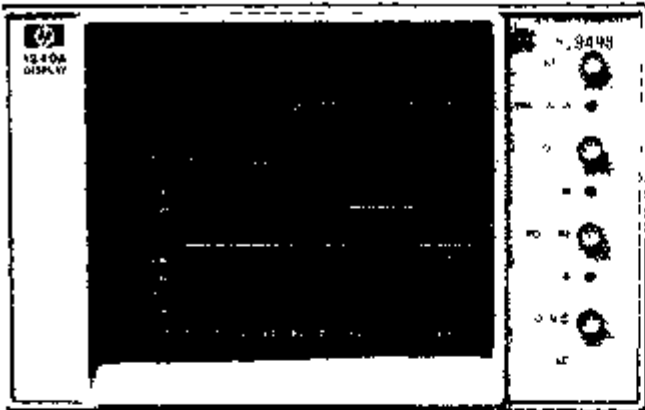

Fig. 6 Closeup view of graphic display with added analog signals.

#### The Portable Console

The portable console (fig. 7) can be connected to any IOMM for local operation of any of its controlled devices. A 5 inch CRT permits display of parameters and monitored values. There is no touch panel, but a row of buttons located immediately below the CRT is software labelable. Two control knobs are provided. It is possible, using the portable console, to modify the ROM data base dynamically. This is done by duplicating the IOMM data base in RAM, and using this for control and possible modification. This is most valuable during checkout of an IOMM, when many of the database parameters (limits, allowable tolerances, etc.) have only been tentatively assigned, and need to be refined while operating the actual device. The revised data base information is then impressed on to a new ROM chip, which then replaces the old ROM chip in the IOMM. The entire process of changing ROM values is fast—a few minutes—while the IOMM is "down" for only the few seconds required to change chips.



Fig. 7 Photo of portable console being used in Cockcroft-Walton terminal.

Another important use for the portable console is to run accelerator equipment tied to the IOMM for checkout during maintenance periods, when the computer control system is also usually down for maintenance or for the installation of new programs, etc. Without such a local control capability, a full set of parallel controls would need to be installed for such critical equipment as in sources and RF, which require operation as an integral part of maintenance.

Finally, the portable console is provided with special programs and output plugs used to checkout and isolate problems associated with control system components such as multiplexors, timing modules, and graphics equipment independent of the IOMM.

#### System Limitations and Plans for Improvement

This control system meets or exceeds all of its design specifications. However, a very important test for any control system is its ability to adapt to new requirements. We will want to add many new controlled elements and many more beam monitoring devices to the present system. With a 36 Kz machine, requirements for data collection and analysis can grow to almost any limit. We would like for the system to be able to handle as much as possible. As the system grows in complexity, reliability considerations will demand memory protection, the ability for the computer to diagnose its own failures, and to fail gracefully. Fortunately, the microprocessor technology that we have chosen to follow is moving in this direction. It will be possible to meet all of these goals inexpensively with standard hardware and with modest software additions.

The currently implemented system can handle about 1000 controlled elements, each requiring 5 channels (such as analog control, analog monitor, etc.). A new board which will soon be available (incorporating Intel iAPX286) will allow us to handle more than 10,000 controlled devices. It will be 5 times faster than the present boards, will have a larger address space (16 megabytes), and will provide for memory protection. Where needed, computations can be speeded up by adding a math chip. We will redo the IOMM so that all serial traffic is 5 times faster by using a single chip microcomputer for each channel. This will also eliminate all multibus traffic due to serial transmission. It will then be possible to put the serial transmission networking into firmware, with the consequence that the IOMM can write to the IOMM just as if it were local memory. This will significantly simplify programming in the IOMM.

With expected improvements in fiber optics links (100 megabits/sec) it will be possible to convert the IOMM to IOMM connection to a serial bus. This will have the effect of making the IOMM appear to be on the IOMM local bus, even though it may be thousands of feet away.

#### References

15. Magyary et al., Proceedings of the 6th ILEE Conf. on Applic. of Accel. in Research and Industry, Denton, TX, Nov. 1980 (LBL-11761).
16. D. Lancaster et al., Proceedings of the 1979 Linear Accel. Conf., Montauk, NY, pp. 269-273 (LBL-5763).

<sup>17</sup>Multibus is a trademark of Intel Corporation.