

THE UPGRADED RING LOSS RADIATION MONITORING SYSTEM AT THE AGS\*

Received by OSTI

BNL--41824

G.W. Bennett, E. Beadle, V. Castillo, R.L. Witkover  
 AGS Department, Brookhaven National Laboratory  
 Associated Universities, Inc., Upton, NY 11973 USA

MAY 26 1989

DE89 012538

Abstract

With the Booster the AGS will accelerate protons to  $3 \times 10^{13}$  per cycle, polarized protons at  $10^{12}$ , and ions from Carbon to Gold at intensities from  $50$  to  $3 \times 10^9$ . A loss monitoring system is being developed to facilitate tuning, and to reduce personnel radiation exposure by minimizing residual induced activity and by allowing remote monitoring of activity in the accelerator enclosure. The monitoring system must have a large dynamic range to monitor high intensity beam losses and to measure induced activity down to the level of a few mrad/hour. Various detectors are being evaluated, including ion chambers, proportional counters, and aluminum cathode electronmultipliers. Measurements of the prompt ionization distribution in the median plane at various energies from point targets at two representative locations in the accelerator lattice have been completed. Details of the monitoring system will be presented, as well as the experimental measurements of the prompt radiation field, and a comparable Monte Carlo calculation.

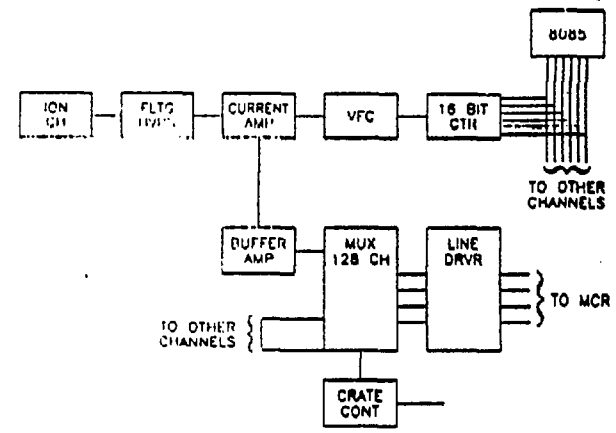

Fig. 1 Block diagram of present RLRM system.

Introduction

The Ring Loss Radiation Monitoring (RLRM) System is used for beam tuning and diagnostics, and to minimize residual activation of the accelerator structure for personnel dose reduction. The present loss threshold (i.e., producing a digital output of one count) for "instantaneous" loss of full energy beam (28 GeV) on a point target is  $5 \times 10^8$  protons. The increasing importance of heavy ion and polarized proton operation of the AGS is heralded by the construction of the Booster, scheduled for commissioning in 1991. Since these new operating regimes will be at least three orders of magnitude lower in intensity than for proton acceleration, an upgraded RLRM system is being developed to provide tuning diagnostics at increased sensitivity, and the capacity to remotely monitor activity induced in the accelerator structure down to a few mrem/hr.

Present System

The present system is comprised of 120 Argon insulated coaxial cable ion chambers, each 5 m long strung below the magnet support girder and spanning a pair of magnets. A block diagram of the system is shown in Fig. 1. Analog signals with temporal resolution of tens of microseconds are available from any four detectors via the multiplexer. Digital signals from all the detectors are acquired in a selected time interval for the current acceleration cycle, as well as the total signal from each detector for all of the previous machine cycle. The present window data are displayed graphically on a terminal of the central control computer. The tabulated digital data may also be displayed, or written to a file for later analysis.

Measurements

It seems evident that with the "C" shaped magnets of the AGS sensitivity will be increased by moving the detectors from below the magnet to the median plane on the open side of the "C". We mounted an array of eight ion chambers on the median plane, on a line just outside the magnet structure, extending up and downstream of two flip targets. Each target, 3 mm of aluminum, constituted a point-like source. One target, J5, was located in the first half of a superperiod where the flux returns of the "C" shaped magnets were outside (i.e., the open side of the magnet faced in); the second target, J19, was in the part of the superperiod where the flux return was inside. A schematic diagram of the experimental setup is shown in Fig. 2. The experimental results are shown in Fig. 3.

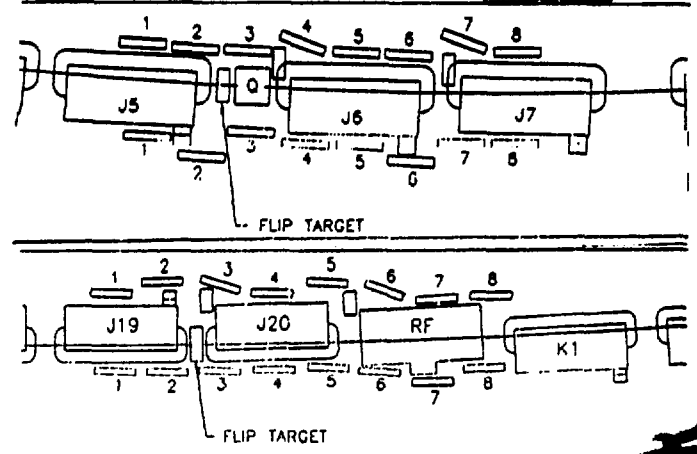

Fig. 2 Schematic drawings of AGS Ring showing detector locations relative to flip targets.

\*Work performed under the auspices of the U.S. Department of Energy.

MASTER

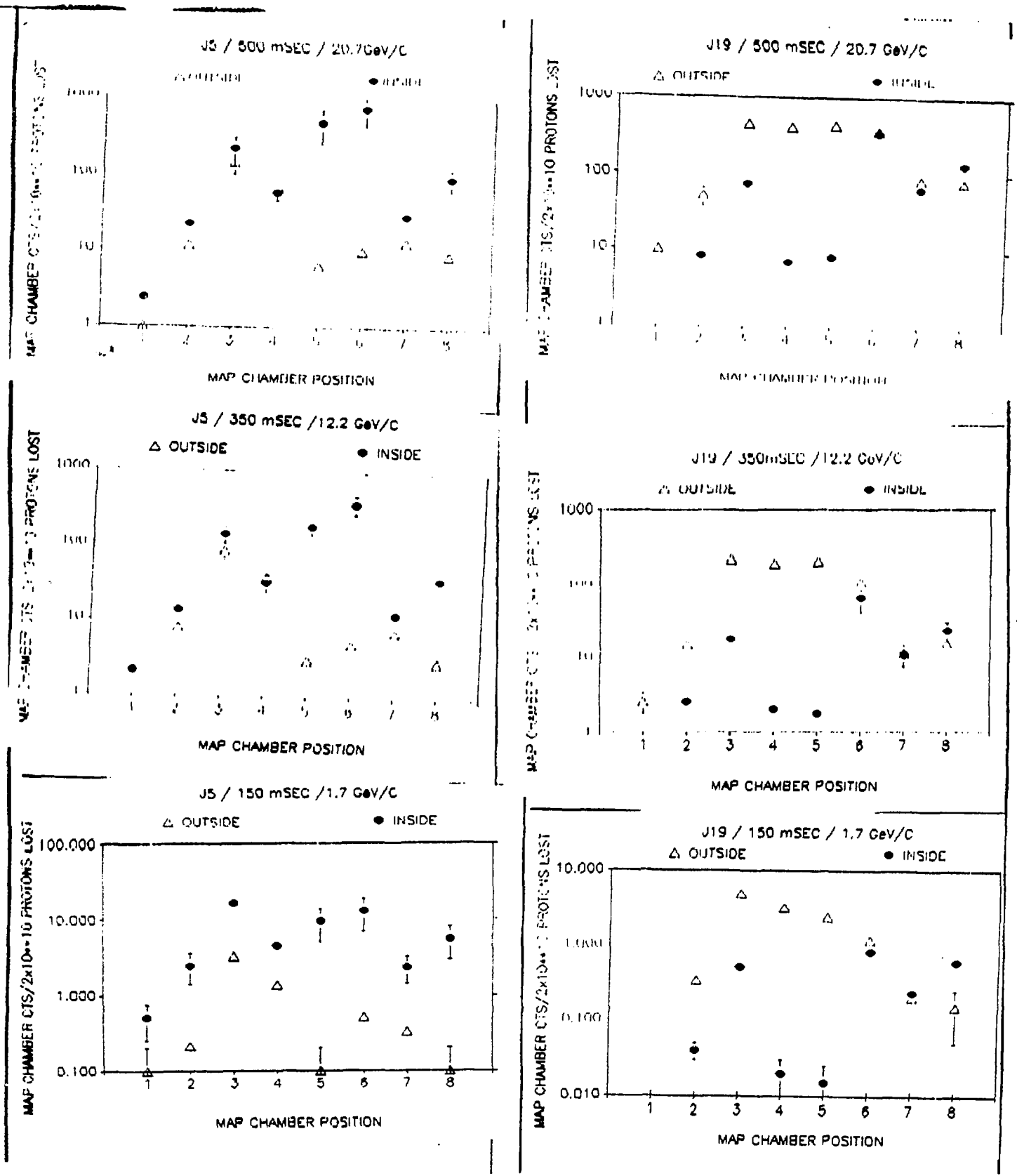

Fig. 3 Prompt ionization in the median plane near jump targets at proton beam momenta of 1.7, 12.2, and 20.7 GeV/c. Experimental setup of detectors as in Fig. 2. Error bars represent standard deviations.

The data were acquired using the eight spare electronics channels of the RIRM System. Data at each of three energies were acquired over a large range of beam losses, using the change in the circulating beam current transformer signal as a measure of beam loss. Data were accepted for analysis only in the range where linearity could be demonstrated for the ion chamber signals relative to the beam loss. Analysis included the standard deviation associated with the 5 to 30 values acquired over the linear range established for each data point. These standard deviations are reflected in the error bars shown in the graphs of the measurement results.

The results show that, allowing for the shielding effect of the quadrupole magnet at J5, the ionization on the median plane is comparable on the open side of the magnets whether facing in or out. In addition, the full width at half maximum of the distribution about J19 is roughly equal to the magnet pitch. An independent measurement suggested that the increase in sensitivity gained by moving the detectors from the present location to the median plane adjacent to the open side of the magnet is about 100 fold.

Calculations were made using the CASIM computer code<sup>2</sup> for comparison with the experimental data. The accelerator structure downstream of the J19 straight section was approximated; the magnets, for example, were assumed to have a simple rectangular cross section with rectangular cutouts to provide the "C" shape. The calculation estimated the energy density summed over regions approximating the detector locations. Since the actual detectors were located somewhat closer to the equilibrium orbit than was assumed, the axial location of the calculated values was adjusted slightly. The calculated data were normalized to the peak value of the experimental data. The results are seen in Fig. 4.

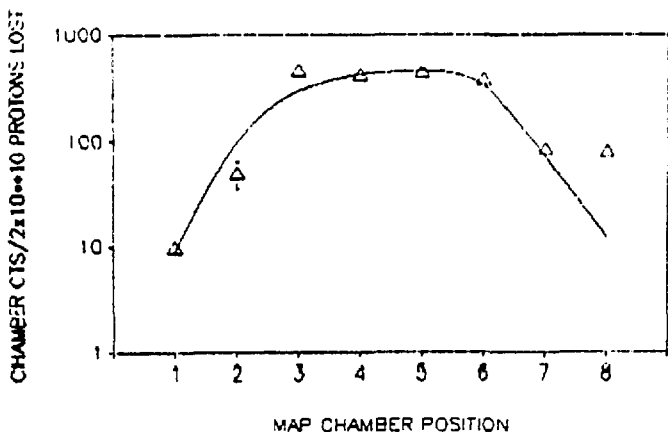

Fig. 4 CASIM Monte Carlo calculation (curve) of energy density at detector locations for comparison with measured data.

#### Proposed System

The detectors for the upgraded system will be located on the median plane on the open side of each magnet. The sensitivity will be three orders of magnitude greater than that of the present system.

A block diagram of the new system is shown in Fig. 5. The system will provide analog integration,

with the integrators sampled and reset every ten milliseconds. Integrator sampling shall also be available during the 10 msec interval between integrator resets, to provide temporal resolution of 1 msec.

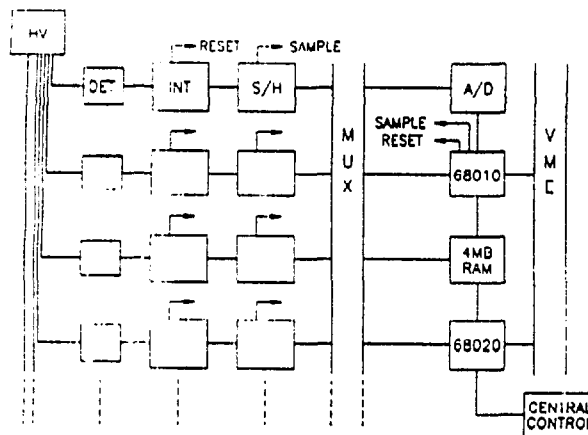

Fig. 5 Block Diagram of Upgraded System.

The central components are a commercially available 68010 based VME bus analog to digital coprocessor board, a dual ported 4 megabyte random access memory, and a 68020 microprocessor to communicate with the central control computer. The analog to digital board is capable of 256 input channels. The time to digitize a channel and store the result in the dual ported memory is only 6 microseconds.

The detectors for the original system will be retained for use during high intensity proton operations, and the electronics will be replaced with a duplicate of that shown for the high sensitivity system.

#### Progress

A number of detector types are presently being evaluated, including ion chambers, proportional counters, and aluminum cathode electronmultipliers. The microprocessors, analog to digital converter, dual ported RAM subsystem has been assembled and tested. Software development for the microprocessors has started. Cabling is scheduled to be installed in the accelerator complex this summer (1989), and the system will be commissioned by the fall of 1990.

#### References

1. R.L. Witkovter, IEEE Trans Nuc Sci NS-26, 3313 (1979).
2. A. van Ginneken, "CASIM Program to Simulate Hadronic Cascades in Bulk Matter", Fermilab FN-272, 1975.

## **DISCLAIMER**

**This report was prepared as an account of work sponsored by an agency of the United States Government. Neither the United States Government nor any agency thereof, nor any of their employees, makes any warranty, express or implied, or assumes any legal liability or responsibility for the accuracy, completeness, or usefulness of any information, apparatus, product, or process disclosed, or represents that its use would not infringe privately owned rights. Reference herein to any specific commercial product, process, or service by trade name, trademark, manufacturer, or otherwise does not necessarily constitute or imply its endorsement, recommendation, or favoring by the United States Government or any agency thereof. The views and opinions of authors expressed herein do not necessarily state or reflect those of the United States Government or any agency thereof.**