

A BEAM SCRAPER USING A LINEAR MOTOR*

BNL--41825

DE89 012543

F.R. Beadle, E.S. Rodger, R.E. Thern
 AGS Department, Brookhaven National Laboratory
 Associated Universities, Inc., Upton, NY 11973 USA

Received by OSTI

MAY 26 1989

Introduction

A beam scraper using a linear motor drive has been developed for use in the AGS at Brookhaven National Laboratory. The device is used to measure beam size by moving a target to a predetermined location and measuring the intercepted beam with nearby loss monitors or by noting the decrease in the circulating beam current. This device has excellent vacuum characteristics, as the motor and sensor coils are outside the vacuum, coupled magnetically to the moving parts which are inside. There are no bellows or dynamic seals required. The position-time profile is controlled by a closed-loop servo system which uses position feedback.

The new beam scraper is designed to be compatible with operation in a vacuum of 10^{-9} Torr. It must be able to function after a lifetime radiation dose of about 10^9 rads, and have a life of some 10^7 operation cycles before failure or leaking.

The positional accuracy of the target should be within 0.15 mm in order to measure the AGS beam, which reaches a minimum size of about 1.5 mm rms. The operational cycle requires that the target be outside the dynamic aperture of the AGS during injection and come in quickly at the desired time to intercept the beam, which may be moving or changing size relatively rapidly. The motion needed is typically 30 mm, in a time of 0.05 sec or less.

Design Goals

The old beam scrapers at the AGS, known as the "flip targets", have been used for beam size measurements and for cleaning up small amounts of beam halo. These targets, which are the descendants of the internal targets once used for the production of secondary beams, have several shortcomings. They hit a mechanical stop to determine their position, stressing the target. This precludes the use of brittle refractory material for the target and thus limits the amount of beam that may be intercepted without melting the target. The motors that flip the target into the beam are inside the vacuum and are expected to be a serious source of outgassing as the AGS vacuum is improved.

Linear Motor

The linear motor, shown in Figure 1, provides a simple, cost effective solution to these design requirements in the following manner. First, it is an inherently high-speed device. Linear motion is initiated directly; there are no gears, levers, or cams. The force is caused by the flux of a permanent magnet cutting through the current of a coil, much like the action of a speaker voice coil. In this case, however, the coil is stationary and the magnet moves, allowing the coil to be outside the vacuum and the moving permanent magnet inside. The linear motor, unlike a solenoid, is bidirectional, has a uniform force over its entire range, and the travel can be made as long as needed.

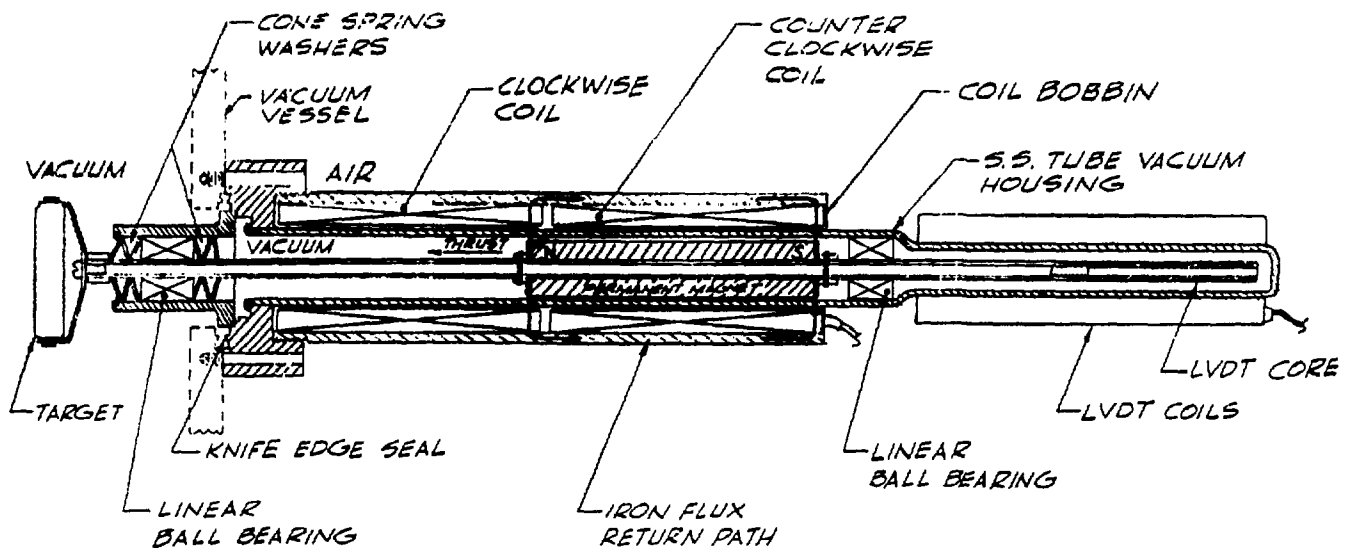

Figure 1. Beam scraper assembly (not to scale).

*Work performed under the auspices of the U.S. Department of Energy.

DISTRIBUTION OF THIS DOCUMENT IS UNLIMITED

MASTER

Seals

Sliding seals at high vacuum levels are considered unsatisfactory, and bellows seals are not compatible with the high speed, long travel, and long life needed. With the linear motor magnetically coupled through the wall of the vacuum chamber, all moving parts are entirely inside the vacuum and no moving seals are needed.

Position Sensing

The position of the moving assembly is measured with a linear variable differential transformer (LVDT). The core of the LVDT is attached directly to the shaft that guides and supports the permanent magnet armature. The LVDT can resolve motions of the order of 0.01 mm, although the overall accuracy and linearity is of the order of 0.1 mm. The LVDT, like the motor, uses magnetic coupling through the vacuum wall and has its electrical coils outside the vacuum.

Radiation Tolerance

The samarium-cobalt magnetic material (CRUCORE 22, 2:17) can be expected to lose less than one percent of its strength with a radiation dose of 10^9 rads.¹ The insulation of the coils has been selected to be resistant to this dose also. The control electronics are about 50 meters away, outside the radiation area.

Life

The device has only one moving part which weighs approximately 0.25 kg and is supported by two linear ball bearings. The bearings are lubricated by molybdenum disulfide and have a projected life of over 10^8 cycles. Since there are no dynamic seals, leaks are unlikely. A possible failure mode is a structural failure resulting from a control malfunction or operator error where the motor is slammed at full power into the stops. To guard against this, a series of cone spring washers is incorporated into the stops in both directions to limit the shock loads to 100 lbs. The unit has purposely been repeatedly impacted into the stops without a failure.

Servicing

The motor stator and LVDT coils can be removed easily without breaking vacuum. The entire device can be removed from the vacuum vessel by removing six conflat seal bolts. The target itself can be replaced by removing a viewing window.

Motion Control

The block diagram of the control system is shown in Figure 2. The system is basically a closed loop servo which follows the desired position-time profile. The feedback loop includes a single pole/zero filter for bandwidth and phase margin control. For faster response, it is necessary to "feedforward" an acceleration signal so a large motor drive can be generated immediately without waiting for a large position error to develop.

A 20 kHz switching amplifier is used, which can deliver peak currents of over 20 A to the motor, giving a force of 4 kg and an acceleration of about 16 g's (160 m/s^2). Because the motor is wound on a conductive bobbin, it is very lossy at the 20 kHz

switching frequency and can get overly hot even when not moving. The series choke reduces the current swing and renders the idle heating negligible. The arrangement shown, using a split choke with the motor balanced between the amplifier outputs, minimizes the capacitive coupling of the 20 kHz switching transients to the vacuum pipe (and thus to other systems - in particular, the LVDT).

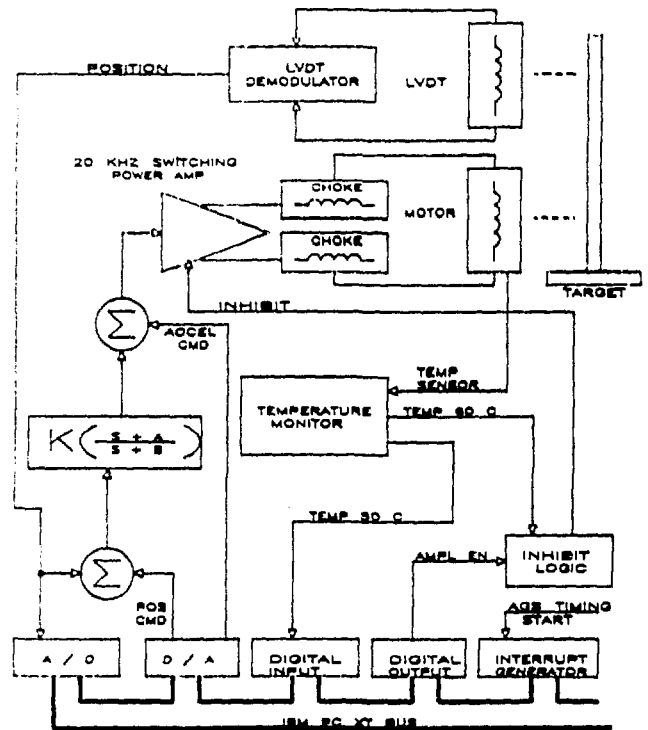

Figure 2. Block diagram of the beam scaper control system.

Protection

The amplifier must be capable of delivering high instantaneous power to the motor--up to 1500 W--in order to start and stop the target quickly. The steady state capacity of the motor, however, is only 30 W, so great care is necessary to avoid damaging the motor in some fault situation. The system here has several levels of temperature sensing and protection. At the lowest level, the computer will refuse to initiate a jump if the temperature of the motor is above 50 C. The ultimate protection against failure of the controls or amplifier is a slo-blo fuse and a Klaxon thermostat on the motor.

Performance

The system can reliably execute an accelerate-decelerate cycle which travels 20 mm in 40 ms, giving a peak speed of 1 m/s. Longer travels are achieved by coasting at the peak velocity. With one setting of the feedforward parameters used for all travel lengths, the overshoot and ringing is in the range of 0.1 - 0.2 mm. The excursion can be done in about 60% of these times, but this requires careful tuning of the feedforward parameters to achieve a small overshoot. It should be noted that for an application like beam profile measurement a moderate overshoot is inconsequential as long as the maximum travel is measured.

The linear motor and LVDT combination may also find use in other vacuum positioning applications, such as flag drives. If the speed requirements are relaxed, much less power is needed and a simpler control system will suffice.

Beam Profile Measurement

The beam profile, as shown in Figure 3, is measured by inserting the target various distances into the beam (on successive AGS pulses) and reading the fractional loss of circulating beam current. Figure 4 shows the target position and beam current vs. time during the operation of the target to get one such data point. The results here use only the beam current transformer. The measurements may be continued further out in the tail of the beam by directly detecting the scattered particles also.

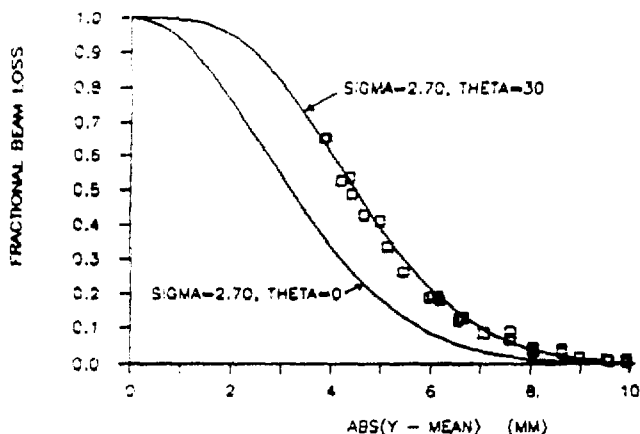

Figure 3. Beam loss vs target position, with a beam intensity of 11×10^{12} protons, and a momentum of 14 GeV/c.

The interpretation of the beam loss profiles depends on the dynamics of the beam. A target positioned at a distance x from the equilibrium orbit removes all particles with an emittance greater than x^2/β . If the beam distribution is Gaussian with width σ , this gives a loss profile shaped like

$$\text{loss} = e^{-(x^2/2\sigma^2)}$$

If there is linear coupling between the horizontal and vertical betatron motions the normal modes of oscillation are no longer exactly horizontal and vertical, but are tilted, and either a horizontal or vertical target alone shaves off beam particles beyond a certain emittance in both normal modes. This is analyzed in Reference 2. If the normal modes are tilted at an angle θ from the horizontal and vertical directions, and the beam has unit σ in both modes, a target at a distance x from the beam center intercepts high emittance particles from both modes and gives a loss pattern

$$\text{loss} = e^{-x^2/\cos^2\theta - \int_0^{x/\cos\theta} \frac{du}{u} e^{-\left(x^2 + (x/\sin\theta - u/\tan\theta)^2/2\right)}} \quad (2)$$

The data in Figure 3 are fitted to Eq. 2 to determine σ and θ . Also shown for comparison is a curve calculated with the same σ but with θ set equal to zero (no coupling). A series of such measurements at differing momenta throughout the AGS cycle requires the extra parameter (θ) of Eq. 2 to give good matches to the data, but then the result widths give an uniform normalized emittance.

The presence of coupling adds a significant complication to determining the beam emittance with the target. Work is continuing to understand it and correlate it to other measures of tune and coupling. However, for determining aperture requirements for extraction equipment (for example), the beam loss profile measured with the target is directly applicable since it automatically includes these complications in the appropriate way.

Acknowledgments

We would like to thank C. Magoulas for early work in control design, and the Beam Components Group and P. Dwyer for assembly.

References

- [1] E.W. Blackmore, "Radiation Effects of Protons on Samarian-Cobalt Permanent Magnets", IEEE Trans. Nuc. Sci. NS-32, No. 5, October 1985, p. 3669.
- [2] A. Antillon and J. Kats, "How the Flip Target Behaves in Four-Dimensional Space", BNL 51942, 1985.

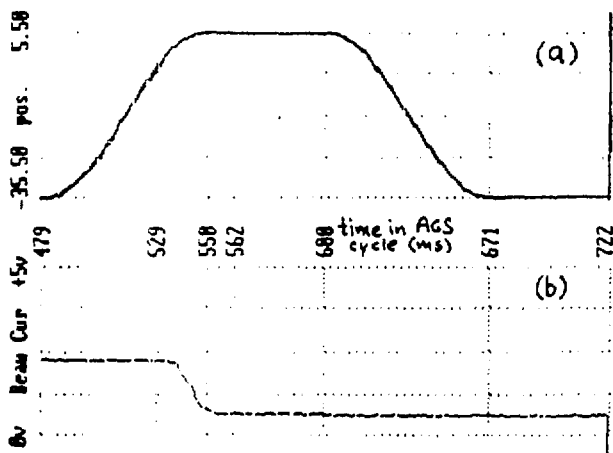

Figure 4. (a) Target position as a function of time during a typical measuring cycle. (b) Beam current as a function of time, showing the loss due to target insertion.

DISCLAIMER

This report was prepared as an account of work sponsored by an agency of the United States Government. Neither the United States Government nor any agency thereof, nor any of their employees, makes any warranty, express or implied, or assumes any legal liability or responsibility for the accuracy, completeness, or usefulness of any information, apparatus, product, or process disclosed, or represents that its use would not infringe privately owned rights. Reference herein to any specific commercial product, process, or service by trade name, trademark, manufacturer, or otherwise does not necessarily constitute or imply its endorsement, recommendation, or favoring by the United States Government or any agency thereof. The views and opinions of authors expressed herein do not necessarily state or reflect those of the United States Government or any agency thereof.