

SCREENING VOLATILE ORGANICS BY DIRECT SAMPLING ION TRAP AND GLOW DISCHARGE MASS SPECTROMETRY

Marcus B. Wise, G.B. Hurst, C.V. Thompson, Michelle V. Buchanan, and Michael R. Guerin

Analytical Chemistry Division
Oak Ridge National Laboratory
Oak Ridge, Tennessee 37831-6120

ABSTRACT

Two different types of direct sampling mass spectrometers are currently being evaluated in our laboratory for use as rapid screening tools for volatile organics in a wide range of environmental matrices. These include a commercially available ITMS ion trap mass spectrometer and a specially designed tandem source glow discharge quadrupole mass spectrometer. Both of these instruments are equipped with versatile sampling interfaces which enable direct monitoring of volatile organics at part-per-billion (ppb) levels in air, water, and soil samples. Direct sampling mass spectrometry does not utilize chromatographic or other separation steps prior to admission of samples into the analyzer. Instead, individual compounds are measured using one or more of the following methods: spectral subtraction, selective chemical ionization, and tandem mass spectrometry (MS/MS). For air monitoring applications, an active "sniffer" probe is used to achieve instantaneous response. Water and soil samples are analyzed by means of high speed direct purge into the mass spectrometer. Both instruments provide a range of ionization options for added selectivity and the ITMS can also provide high efficiency collision induced dissociation MS/MS for target compound analysis. Detection limits and response factors have been determined for a large number volatile organics in air, water, and a number of different soil types.

INTRODUCTION

Direct sampling mass spectrometry for the measurement of trace levels of volatile organics in environmental matrices has a wide range of important field screening applications. These include the

measurement of volatiles in waters, soils, oily wastes, stack emissions, and ambient air, among others. In addition, real-time "sniffing" capability provides a convenient means of detecting soil gas emissions, leaking waste containers, and probing the atmosphere in enclosed storage facilities.

Because of their small size, relative simplicity, ruggedness, and low power consumption, conventional quadrupole mass spectrometers and quadrupole ion trap mass spectrometers are especially attractive for transportable field screening applications. In fact, several commercial quadrupole based instruments are currently available for field monitoring applications and recently, several different research groups have been developing and demonstrating transportable ion trap mass spectrometers for on-site GC/MS applications (1-3).

This paper describes the use of an ion trap mass spectrometer and a tandem source glow discharge mass spectrometer for the direct measurement of ppb levels of volatile organics in air, water, and soil. Because these instruments do not use chromatographic separation prior to admitting a sample into the mass spectrometer, the response time is virtually instantaneous and accurate quantification of target analytes can be accomplished in less than 2 minutes. Although the tandem source quadrupole mass spectrometer is somewhat limited in its ability to handle complex samples, the ion trap mass spectrometer has the capability of selective ion storage and multiple stages of collision induced dissociation for much greater specificity.

Laboratory-based instruments are currently being used to develop and validate methods for direct air monitoring and the screening of water, soil and waste samples. A transportable ion trap mass spectrometer for field use is under construction in our laboratory and will be initially tested in 6-9 months.

EXPERIMENTAL

Instrumentation

Ion Trap Mass Spectrometer

All ion trap experiments were performed with a Finnigan MAT Corporation ITMS ion trap mass spectrometer. Our instrument is equipped with a specially designed vacuum chamber which is electropolished on the inside and pumped to high vacuum with two air cooled 330 L/sec turbomolecular pumps (Figure 1). The vacuum chamber and analyzer cell are maintained at a constant temperature of 120° C by means of infrared heating lamps which help to minimize the adsorption of contaminants on the analyzer surfaces. This instrument is also equipped with the necessary hardware and software to perform electron impact (EI) and chemical ionization (CI), as well as selective ion ejection, and collision induced dissociation multiple-step (tandem) mass spectrometry experiments (MS/MS). Control of the instrument and data acquisition are performed with an IBM AT compatible computer using software provided by the manufacturer.

The standard chromatographic interface provided with the ITMS instrument has been replaced with a custom designed interface developed in our laboratory. This interface consists of a short length (14 inches) of 110 micron ID uncoated fused silica capillary tubing which is maintained at atmospheric pressure at one end and high vacuum at the other end. The high vacuum end of the capillary is inserted directly into the ITMS analyzer cell and the atmospheric pressure end is connected to a quick-coupling device which allows rapid switching of sampling modules for different monitoring applications. The gas flow rate through the capillary restrictor is approximately 0.5-1.0 mL/min. Because the samples are introduced directly into the ion trap cell, the manifold pressure is maintained at a lower pressure. This is believed to help reduce deterioration of the electron filament and the electron multiplier. For example, even when sampling water-saturated air for extended periods of time, the electron filament lifetime has been approximately 6 months and the multiplier lifetime has been in excess of 12 months.

ITMS Air Sampling Probe

For direct air monitoring experiments, a special sampling system has been developed as shown by the diagram in Figure 2. This system consists of an 1/4 inch OD teflon transfer line which is connected at one end to the air sample generation system and at the other end to a sampling "cross" arrangement which allows helium to be mixed with the air sample prior to entering the ITMS. The helium is necessary as a buffer gas in the ITMS to collisionally cool ions, thus reducing loss of ions from the trap and improving the overall performance. A pulsed valve is used to meter helium

into the air stream providing approximately an order of magnitude increase in sensitivity relative to a fixed-ratio, continuous mixing of helium with the air. A vent port also located on the inlet "cross" of the sampling system allows the gas stream to be continuously sampled at a high flow rate, thus decreasing the response time for the mass spectrometer. The other port of the inlet "cross" is connected to a short section of uncoated fused silica megabore capillary which is used as an "open/split" interface with the ITMS by inserting 1 inch of the microbore capillary restrictor into the other end of the megabore tubing. Approximately 2 L/min of air is drawn through the megabore tubing by means of a small sampling pump; however, a metering valve located between the pump and the splitter can be used to reduce the pumping speed if desired. This combination of active pumping and the use of the open/split capillary interface minimizes the dead volume in the inlet system leading to a response time of only a few seconds.

Purge Device for Water and Soil samples

For the measurement of volatile organics in water and soil samples (slurries), the air sampling probe is simply replaced with a high speed needle sparge purge device as shown in Figure 3. This device accepts standard 40 mL VOA vials which mount directly on the needle sparger. A pressure regulator and a precision needle valve control the flow of helium purge gas through the sample and the purged components exit through a 10 inch length of megabore capillary tubing. Normal helium flow rates vary from 100 to 200 mL/min which efficiently purges the volatile components from a room temperature sample in less than 5 minutes. The purge device connects directly with the capillary restrictor interface in an open-split configuration with a split ratio of approximately 100:1. The bulk of the sample is diverted to the vent port. As an added feature for screening applications, the vent port is capable of accepting resin cartridges for trapping of components that would normally be vented. This enables the collection of an archived sample which may be sent back to a central laboratory for confirmatory analysis by GC/MS.

Tandem Source Quadrupole Mass Spectrometer

The tandem-source quadrupole mass spectrometer (TSMS) is a prototype instrument constructed using an EXTREL C-50 quadrupole mass spectrometer as the basic system. This instrument was configured with 3/4" diameter rods for high transmission efficiency and a 300 watt RF power supply for a maximum mass range of 500 amu. Control of the instrument is provided by a Dell 325 computer using software written in our laboratory. An axial EI source was purchased with this instrument for testing purposes and for generating conventional 70 eV electron impact spectra.

In order to produce a versatile instrument for environmental monitoring applications, the configuration of the standard C-50 mass spectrometer was extensively

modified. In addition to the axial EI source which was purchased with the spectrometer, a glow discharge ionization source was designed and constructed for this instrument. This source is housed in a differentially pumped vacuum chamber which is separated from the rest of the mass spectrometer by a 1.5 mm diameter vacuum conductance limit as shown in Figure 4. The glow discharge source is typically maintained at a pressure of 0.25 torr while the analyzer is maintained at 2×10^{-5} torr. Ions generated by glow discharge ionization pass through a lens assembly into the high vacuum portion of the instrument where they enter the lens assembly of the axial EI source and are subsequently focussed into the mass analyzer.

Air samples can be introduced into the tandem source quadrupole mass spectrometer by two different methods, either through the differentially pumped glow discharge source chamber, or directly into the electron impact source by means of a simple capillary restrictor. Both inlet systems have been designed so that they are directly compatible with the same sampling devices used with the ion trap mass spectrometer. Thus, essentially the same apparatus and experimental conditions are used for direct purging of water and soil samples regardless of the mass spectrometer used. The only difference is the ability of the glow discharge ionizer to sample air directly without the need for the air sampling pump and open/split interface used with the ITMS.

Dynamic Sample Generator

A dynamic sample generation apparatus is used to produce known concentrations of volatile organic analytes in an air stream. This apparatus was used for the determination of instrumental detection limits for real-time air monitoring experiments. It basically consists of a variable speed syringe pump and a dilution air manifold as shown in Figure 5. The syringe pump continuously meters small amounts of organic compounds into a controlled stream of air. Concentrations of the analytes can be easily varied by adjusting the speed (metering rate) of the syringe pump and/or by changing the flow rate of dilution air through the manifold. Turbulent mixing of the organic compounds and the dilution air occurs in the manifold line which provides a homogeneous concentration at the sampling ports.

Components of the dynamic sample generator include a Razel Instruments model A-99 syringe pump equipped with a 5 mL syringe, a 100 psi air supply line equipped with an on/off toggle valve and a precision metering valve, a 1.5 m x 6 mm Teflon line (dilution manifold), and two 1/4 inch Swagelock sampling ports. The apparatus produces continuous and stable generation of organic concentrations in air and also allows rapid changes in concentration without having to wait excessively to reach a steady-state concentration.

Air containing the desired concentration of individual organic compounds is typically generated by metering a (1:1) water/methanol solution containing approximately 400 ug/mL of the organic compound into the dilution air stream using the syringe pump. The flow rate of the syringe pump can be continuously varied from 8.47×10^{-4} mL/min to 0.0503 mL/min. The dilution air flow is typically adjusted for a rate of 25 L/min through the manifold. As this air flows rapidly past the syringe pump needle, it quickly vaporizes the volatile organics and the solvent. Liquid flow from the syringe, however, must be maintained low enough to prevent condensation in the system. By knowing the concentration of the organic in the liquid solution, the flow rate out of the syringe, and the flow rate of the dilution air, the concentration of the organic compounds in the air can be readily calculated. This assumes that there is minimal adsorption of analytes on the walls of the manifold and complete vaporization of the liquid into the dilution air.

Operating Conditions

Ion Trap Mass Spectrometer

Most of the ion trap data presented in this paper was generated using electron impact ionization conditions. Scan functions for the acquisition of mass spectra were written using the scan function editor program supplied with the commercial software. Typically, for optimum sensitivity the electron ionization time was 50 msec. Low mass cut-off was 60 amu, preventing the storage of ions due to water and air. The mass scan range was approximately 50 to 200 amu which enabled the detection of major ions for each of the volatile organic compounds. In order to improve the signal-to-noise ratio, 16-25 microscans were averaged per displayed scan. Axial modulation was used for all experiments in order to achieve optimum instrument performance. Helium buffer gas was admitted into the system exclusively through the sample transfer line.

Tandem Source Quadrupole Mass Spectrometer

The glow discharge ionization source is specifically designed for high sensitivity direct air monitoring applications. Air is admitted into the ionization region through a metering valve at a flow rate of 0.5-1.0 standard mL/min while a 160 L/min roughing pump maintains the pressure in the ionizer at a constant 0.25 torr. Coaxial ionization electrodes are used for the discharge and consist of a 1 cm diameter x 2 cm long hollow cathode with a 20 gauge wire anode. A potential difference of approximately 600 volts is sufficient to strike and maintain a discharge in the source. Ionization of organic compounds in this source is the result of ion molecule reactions which produce proton transfer and charge exchange reaction products. Conditions within the glow discharge source can be adjusted to optimize either proton transfer or charge exchange reactions. The proton transfer reactions provide high sensitivity for compounds which have proton affinities greater than that of water (which is the primary proton

transfer reagent). Charge exchange on the other hand, is a much more universal ionization method and produces fragmentation spectra which are similar to electron impact ionization spectra. By operating the glow discharge source at low pressures, the formation of water cluster ions which often hamper API mass spectrometers is nearly eliminated, improving sensitivity and decreasing the complexity of the spectra.

Direct sampling using the electron impact ionization source of the quadrupole mass spectrometer is accomplished by means of a 1 meter length of 110 micron ID uncoated fused silica capillary tubing. A simple on/off valve between the capillary and the source allows the restrictor to be isolated when not in use. The conditions in the ionizer include an electron current of 0.5 to 1.0 milliamps and an electron energy of 17 to 20 eV. The use of lower electron energies helps to minimize fragmentation, thus concentrating ion current in fewer ions.

Samples and Chemicals

Individual samples of 31 different volatile organic compounds from the USEPA Toxic Compound List were obtained from Ultra Scientific Company as solutions of the neat compound dissolved in methanol at a concentration of 10,000 ppm. Solutions for use in the dynamic sample generation system were prepared from the methanol stock solutions using ultra-pure water and spectroscopic grade methanol. In order to verify the proper calibration and performance of the dynamic sample generation system, certified standards of volatile organics in nitrogen were purchased from Scott Specialty Gases.

Water samples were prepared using distilled water containing 0.15 g/L of sodium chloride and 0.17 g/L of sodium sulfate. A series of concentrations of individual volatile organics from approximately 1 ppb to 200 ppb in water was prepared by injecting a known concentration of a methanol solution into water and then carefully pipetting the water standard into a 40 mL pre-cleaned VOA vial. The vials were capped with Teflon lined septa until used. Most samples were prepared at approximately pH 7; however, samples of benzene, trichloroethylene, and tetrachloroethylene were also prepared at pH 2 and pH 10.

A total of 5 different soil samples were examined as part of this study including 2 soils provided by the U.S. Army Toxic and Hazardous Materials Agency (USATHAMA), 2 local soils, and a potting soil. These represent a range of soil types including clay, sand, and high humic content. The soil samples were prepared by injecting a pre-weighed 5 gram sample of soil in a 40 mL VOA vial with a known quantity of the volatile organic in methanol and allowing it to sit for a short

period of time. Slurries of the soil samples for direct purge experiments were prepared by adding 25 mL of water to the sample and allowing them to sit for at least 1 hour prior to analysis.

RESULTS AND DISCUSSION

Volatile Organics in Air

The primary objective of the air monitoring study was to optimize the experimental conditions and determine the real-time detection limits for a representative sample of volatile organic pollutants. This sensitivity assessment was performed using standard electron impact ionization on both the tandem source quadrupole mass spectrometer and the ITMS. This enables comparison of our results with other mass spectrometer systems which are commercially available and use electron impact ionization. For all ITMS experiments, the electron ionization time was 50 msec. Mass scan ranges were selected as appropriate for each compound although the lower mass cut-off was normally at least 40 amu or higher. This prevented water, nitrogen, and oxygen ions from being stored in the ion trap simultaneously with the analyte ions, thus minimizing the effects of space charge and unwanted ion-molecule reactions. Future studies will involve a comparison of sensitivities for chemical ionization and electron impact ionization.

Using the ITMS instrument, sensitivities for the 31 volatile organics were determined. However, pumping problems with the tandem source quadrupole mass spectrometer restricted experiments to the determination of detection limits for only 3 compounds: benzene, trichloroethylene, and tetrachloroethylene. For both instruments, response curves (instrument response vs. concentration in air) were prepared for each of the compounds studied. The range of concentrations examined was generally between 4 and 200 ppb. A typical experiment involved the acquisition of a background level signal, followed by the acquisition of spectra for a series of decreasing concentrations in air generated with the dynamic sample generator. Instrument response vs. time produced a "stair-step" curve as the concentration of organic was reduced to successively lower levels. Each concentration level was maintained for several minutes to ensure that a steady state concentration was reached before further reducing the level.

Ion Trap Mass Spectrometer

An electron impact mass spectrum of a mixture of volatile organics in air is shown in Figure 6. This mixture contained carbon disulfide, benzene, chloroform, toluene, and ethyl benzene at concentrations of approximately 1 to 10 ppm. As shown in this figure, space-charge-induced peak broadening and mass shifting are not significant.

A typical "stair-step" air monitoring response curve acquired with the ITMS is shown in Figure 7. This is a

reconstructed plot of the ion current for m/z 83 as "seen" by the ITMS instrument vs. time for a sample of chloroform in air. As the concentration of the chloroform was decreased to lower values over a period of time, the response of the ITMS decreased proportionally. This same type of plot can be generated in real-time continuous monitoring applications, allowing changes in the concentration to be readily visualized. As shown in Figure 7, the response time of the ITMS to changes in concentration was very fast (less than 15 seconds) and the time required for the sample generator to reach steady state at a new concentration was typically less than 3 minutes.

In addition to the continuous plotting of the ITMS total ion response, it is also possible to monitor the actual mass spectrum in real time in order to detect changes in specific ion intensities. This is especially useful whenever multiple components are present in a sample. All of the information which is generated in real-time may be stored on a hard disk as a temporal series of mass spectra, allowing response curves for any ion in the mass range to be reconstructed, plotted, and integrated. An example of a post-processed mass spectrum of chloroform in air is shown in Figure 8.

An important feature of the response curves generated with the ITMS is the pseudo-sinusoidal waveform superimposed on the curve. This is not actually noise, but is actually an effect due to the pulsed valve addition of helium into the air stream. Maxima correspond to the optimum helium/air ratio and minima correspond to the least effective helium/air ratio. By synchronizing the pulsing of the helium valve with the acquisition of the spectral scans, this effect should be nearly eliminated.

The experimentally determined detection limits for the 31 volatile organic compounds in air are presented in Table 1. As shown in this table, the detection limits are generally in the low ppb range which is comparable to the sensitivity of some commercially available API mass spectrometers. Exceptions to this include bromoform, chloroethane, and chloromethane. However, because chloromethane and chloroethane are extremely volatile (boiling points of 24°C and $+12.3^{\circ}\text{C}$, respectively), it is likely that these compounds were lost during preparation of the standard. Bromoform, on the other hand, is less volatile than most of the compounds examined, with a boiling point of $+150.5^{\circ}\text{C}$. Bromoform probably condenses on the walls of the vapor generating system at room temperature and never reaches the ITMS inlet. With proper sample preparation techniques and a shorter, heated sampling line, detection limits for chloromethane, chloroethane, and bromoform would probably be more comparable to the other compounds studied. This is a reasonable assumption since these compounds are chemically very similar to other

halogenated hydrocarbons that have been successfully measured and would be expected to have similar ionization efficiencies under electron impact ionization conditions.

The detection limits which are reported for volatile organics in air, were calculated using the RMS (root mean square) variation in the signal measured with no sample present (a blank). This is an accurate determination of the analytical detection limit and represents the lowest concentration of a compound in air that can reliably be observed with the current sampling interface and ITMS operating parameters. For these calculations, the lowest reliably measured signal is defined as the average of the blank signal plus three times the RMS variation in this signal. From the lowest reliably measured signal, the detection limit can be calculated from a calibration curve relating signal to concentration. Linear least squares calibration curves were constructed for the 31 volatile organics studied. Due to space charging effects encountered with a few compounds, a quadratic model was necessary to describe a better fit for the data.

Tandem Source Quadrupole Mass Spectrometer

Detection limits for benzene, trichloroethylene, and tetrachloroethylene in air were also determined using the tandem source quadrupole mass spectrometer. Various concentrations of the individual compounds were generated using the dynamic sample generator as previously described. One signal averaged mass spectrum ($n=36$) was acquired and stored for each concentration. Signal averaged background samples were also acquired and subtracted from the mass spectra of the actual samples. Experimental difficulties arising from a high hydrocarbon background in the instrument complicated these low-level analyses. The background problem was due to backstreaming of diffusion pump oil and condensation on the ionization source.

Linear regressions of the data were calculated and both data and regression were plotted for each compound. Due to the nature of the signal averaging experiments, an accurate detection limit could not be determined for the three compounds using the same RMS noise calculation method as the ITMS. Rather, the detection limit was determined by calculating the standard deviation of the linear regression plot and then determining the concentration at which the signal is equal to the standard deviation⁴ as shown in Figure 9. The regression curve for benzene in air is shown in Figure 10 and the calculated detection limit was determined to be approximately 11 ppb. Based on the linear regression curves for trichloroethylene and tetrachloroethylene, detection limits for these compounds were determined to be approximately 42 and 29 ppb respectively.

Although the electron impact ionization was used predominantly for this study, earlier experiments with the glow discharge ionization source indicate that the detection limits are very similar to or slightly better than those

achievable with the electron impact ionization source. In fact, the tandem source configuration of the quadrupole mass spectrometer is unique and provides extra versatility in terms of sample introduction and ionization options relative to a conventional electron impact ionization quadrupole. For example, air may be sampled and ionized directly with the glow discharge source or it may be sampled through a capillary restrictor and ionized with the axial electron impact ionization source. Since both ionization sources are simultaneously installed on the spectrometer, switching between ionization modes or sample inlet systems is a simple matter of opening the appropriate valve and turning on the electronics for the selected source.

The advantages of the glow discharge source relative to the electron impact ionization source are that it is more rugged for long term operation, the response time is virtually instantaneous, and the source is very tolerant of high oxygen and water saturated atmospheres. Primary advantages of the axial electron impact ionization source are ease of operation and the ability to produce library searchable mass spectra. A major problem with the electron impact source is that the filament assembly is very susceptible to oxidation and burn-out if exposed to large amounts of oxygen or water. For example, when performing direct air monitoring experiments with the electron impact source, the filament must be replaced every 3 to 4 weeks.

Volatile Organics in Water and Soil

The sample handling apparatus and methods for the determination of volatile organics in water and soil slurries are identical for both the ITMS and the TSMS experiments. Volatile organics are purged from a water or soil slurry directly into the mass spectrometer without any preconcentration such as trapping on a resin cartridge. In the simplest case, conventional electron impact ionization spectra are continuously acquired over a mass range of approximately 40-200 amu in order to observe the response for ions corresponding to the purged volatile organics. As shown in Figure 11, the purge profiles for a particular ion can be reconstructed as a plot of response versus purge time. At a helium purge flow of 200 mL/min, purging is normally 90% or more complete after 3 minutes. The area beneath a purge profile correlates well with the concentration of the analytes in the sample as shown in Figure 12. Quantification is accomplished simply by integrating the area of a reconstructed purge profile for the ions corresponding to the target analytes. A typical calibration curve for benzene in water from 1 to 100 ppb is shown in Figure 13. Using carefully prepared standards, correlation coefficients of better than 0.998 are possible. Quantitative reproducibility of less than 10% at the 95% confidence level can also be achieved for water samples without the use of internal standards.

A series of experiments were conducted in which the detection limits, relative response factors, and standard spectra were generated for a series of volatile organics in water. In addition, studies with benzene, trichloroethylene, and tetrachloroethylene were also conducted in order to examine the effects of pH and soil type on the purge efficiency of water samples and soil slurries relative to solutions of volatile organics in pH-7 water. Data for these samples were acquired simultaneously using both the ITMS and the TSMS instruments in order to compare detection limits and quantification accuracy.

The detection limits for 21 different volatile organics in pH-7 water using the ITMS and electron impact ionization are shown in Table 2. These range from approximately 3 ppb for benzene to approximately 60 ppb for dichloroethane and appear to be routinely achievable using the direct purge method. For comparison, the detection limits for compounds purged into the TSMS are also typically less than 200 ppb, although they are generally not quite as good as can be achieved with the ITMS. Accurate detection limits for acetone, 2-butanone, and 4-methyl-2-pentanone have not yet been established due to much lower purge efficiencies.

The matrix effect experiments which were conducted for benzene, trichloroethylene, and tetrachloroethylene appeared to show essentially the same purge efficiency at pH-2, pH-7, and pH-10. Similar results for these compounds were also obtained for a potting soil leachate with a high humic content. These results suggest that accurate quantification may be achieved without the need for extensive sample preparation or the use of internal standards for many water samples. An exception to this may be water samples which contain a high surfactant concentration, although comparative data have not yet been generated.

As opposed to the water samples, differences in the purge efficiencies for volatile organics in soil slurries are more pronounced. As shown in Table 3, the relative purge efficiency for benzene, trichloroethylene, and tetrachloroethylene ranges from approximately 25% to 90% relative to pH-7 water. The least efficient purging was from the soils which had a high clay content and the most efficient purging was from soils having the highest sand content. Although the general trend exhibited by these results is probably reasonable, the actual purge efficiencies are probably better than the data indicate. For example, comparative purge profiles for benzene, trichloroethylene, and tetrachloroethylene in pH-7 water and a potting soil slurry are very similar as shown in Figure 14.

Apparent differences in purge efficiency most likely reflect inefficient stirring and sample purging using a single needle sparger. Further studies have also shown that there was probably significant loss of volatiles from the soil samples during the preparation step using our soil spiking

procedure. Improvements in the purging of soils samples could probably be achieved by simultaneously stirring samples to ensure more homogeneous sparging. Further, the use of an internal standard would be useful to help minimize quantitative errors due to differences in purge efficiency.

CONCLUSIONS

The results of these studies have demonstrated the feasibility of using direct sampling mass spectrometry for the real-time detection of trace organic compounds in air, water, and soils. Detection limits for both the tandem source quadrupole mass spectrometer and the ion trap mass spectrometer are generally in the range of 5 to 200 ppb for water and soil samples without any sample preparation or preconcentration. The detection limits for volatile organics in air using the ITMS range from approximately 1 to 45 ppb for the 31 volatiles studied which is approximately 1,000 times lower than the threshold limit values (TLV's) for these compounds. These detection limits are comparable to those that can be achieved with API mass spectrometers. Detection limits for the compounds studied using the TSMS are slightly worse than those obtained with the ITMS; however, they also are well below the published TLV's. This suggests that the ITMS or TSMS could indeed be useful for field monitoring of stack emissions and soil gas emissions at hazardous waste sites.

Although it is not likely that significant improvements can be made in the detection limits achieved with the TSMS, modification and optimization of the sampling interface for the ITMS will probably result in even better detection limits than reported in this document. In addition, the ITMS instrument also has the capability of chemical ionization which can be used to selectively enhance certain target analytes relative to other compounds in a sample stream.

Both the TSMS and ITMS have excellent detection limits for volatile organic compounds in air, water, and soil; however, experience with the two different mass spectrometer systems suggests that the ion trap mass spectrometer overall is a more useful instrument for continuous air monitoring. Specifically, the ITMS is highly reliable, easier to operate, and more stable than the tandem source quadrupole mass spectrometer. Further, the ion trap mass spectrometer has the capabilities of controlled chemical ionization, selective ion storage, and collision induced dissociation (CID) tandem mass spectrometry (MS/MS). These features are especially important in helping to identify individual components in a complex sample, especially since no chromatographic separations are performed on the sample prior to entering the mass spectrometer. Without these features, the TSMS is restricted to

monitoring samples that typically have fewer than 10-15 components. Finally, due to the simplicity of the ion trap analyzer assembly, this type of instrumentation lends itself to downsizing, portability, and remote operation better than the TSMS.

While the results of this study have been quite successful and demonstrate the potential of the instrumentation for screening of environmental samples, much work remains. Especially important is the development of methods for the identification and quantification of compounds in complex mixtures. This work will involve a thorough examination of chemical ionization reactions, the generation of MS/MS spectra of commonly encountered organic pollutants and potential interferences, and the development of computer programs to process this information in real time.

ACKNOWLEDGEMENT

Research sponsored by the U.S. Army Toxic and Hazardous Materials Agency under Interagency Agreement 1769-A073-A1 under U.S. Department of Energy Contract DE-AC05-84OR21400 with Martin Marietta Energy Systems, Inc.

"The submitted manuscript has been authored by a contractor of the U.S. Government under contract No. DE-AC05-84OR21400. Accordingly, the U.S. Government retains a nonexclusive, royalty-free license to publish or reproduce the published form of this contribution, or allow others to do so, for U.S. Government purposes."

REFERENCES

1. McClennen, W.H., Arnold, N.S., Sheya, S.A., Lighty, J.S., Meuzelaar, H.L.C., "Direct Transfer Line GC/MS Analyses of Incomplete Combustion Products from the Incineration of Medical Wastes and the Thermal Treatment of Contaminated Soils", Proc. 38th ASMS Conf. on Mass Spec. All. Topics, Tucson, AR, 1990, 611-612.
2. Leibman, C.P., Cannon, T.M., Wolf, M.A., Hemberger, P.H., "Real-Time In-Situ Point Monitoring by Ion Trap Mass Spectrometry", Proc. 37th ASMS Conf. on Mass Spec. All. Topics, Miami Beach, FL, 1989, 1429-1430.
3. Wise, M.B., Buchanan, M.V., Guerin, M.R., "Rapid Environmental Organic Analysis by Direct Sampling Glow Discharge Mass Spectrometry and Ion Trap Mass Spectrometry", Oak Ridge National Laboratory TM-11538, Oak Ridge Tennessee, 1990.
4. Hubaux, A.; Vos, G., Anal. Chem., **235**, 1967, 849-855.

Table 1

Detection Limits for Volatile Organics in Air using Direct Sampling ITMS

<u>Compound</u>	<u>Detection Limit (ppb)</u>
1,1,1-Trichloroethane	2
1,1,2,2-Tetrachloroethane	3
1,1,2-Trichloroethane	20
1,1-Dichloroethane	16
1,1-Dichloroethene	6
1,2-Dichloroethene	3
1,2-Dichloropropane	45
2-Butanone	48
4-Methyl-2-Pentanone	17
Acetone	22
Benzene	5
Bromodichloromethane	4
Bromoform	> 80
Bromomethane	>280
Carbon Disulfide	25
Carbon Tetrachloride	16
Chlorobenzene	2
Chloroethane	>209
Chloroform	3
Chloromethane	>268
Cis-1,3-Dichloropropene	6
Dibromochloromethane	12
Ethylbenzene	2
Methylene Chloride	12
Tetrachloroethylene	8
Toluene	3
Trans-1,3-Dichloropropene	7
Vinyl Acetate	44
Vinyl Chloride	5
O-Xylene	4

Table 2

Detection Limits for Volatile Organics in pH-7 Water using Direct Purge ITMS

<u>Compound</u>	<u>Detection Limit (ppb)</u>
1,1,1-Trichloroethane	12
1,1,2,2-Tetrachloroethane	28
1,1,2-Trichloroethane	18
1,1-Dichloroethene	33
1,2-Dichloroethane	27
1,2-Dichloroethene	21
Benzene	3
Bromoform	15
Carbon Disulfide	18
Carbon Tetrachloride	16
Chlorobenzene	5
Chloroform	20
Cis-1,3-Dichloropropene	6
Ethylbenzene	4
Methylene Chloride	60
Styrene	5
Tetrachloroethylene	5
Toluene	4
Trans-1,3-Dichloropropene	15
Vinyl Chloride	5
Xylenes (total)	4

Table 3

Purge Efficiency of Volatile Organics in Soil Slurries Relative to pH-7 Water

<u>Soil Sample</u>	<u>Soil Type</u>	<u>Relative Purge Efficiency (%)</u>		
		<u>Benzene</u>	<u>Trichloroethylene</u>	<u>Tetrachloroethylene</u>
THAMA 1	Clay	29	20	19
THAMA 2	Sand/Clay	51	48	46
Local 1	Sand/Clay	61	45	61
Local 2	Sand/Clay/Humic	46	42	42
Potting	Sand/Humic	91	77	53

ION TRAP MASS SPECTROMETER

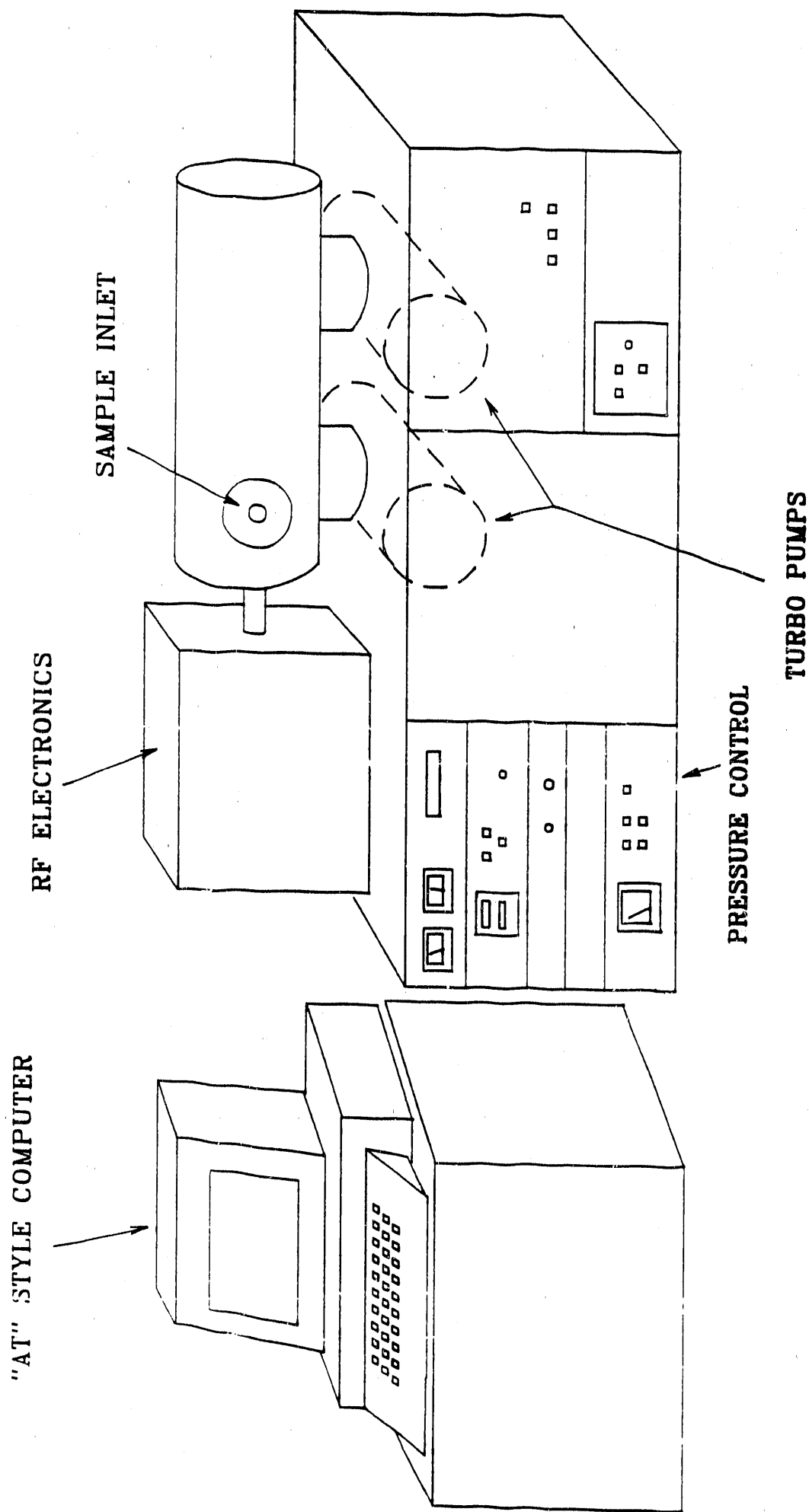

Figure 1 Diagram of the ITMS ion trap mass spectrometer.

ITMS Inlet for Direct Air Monitoring

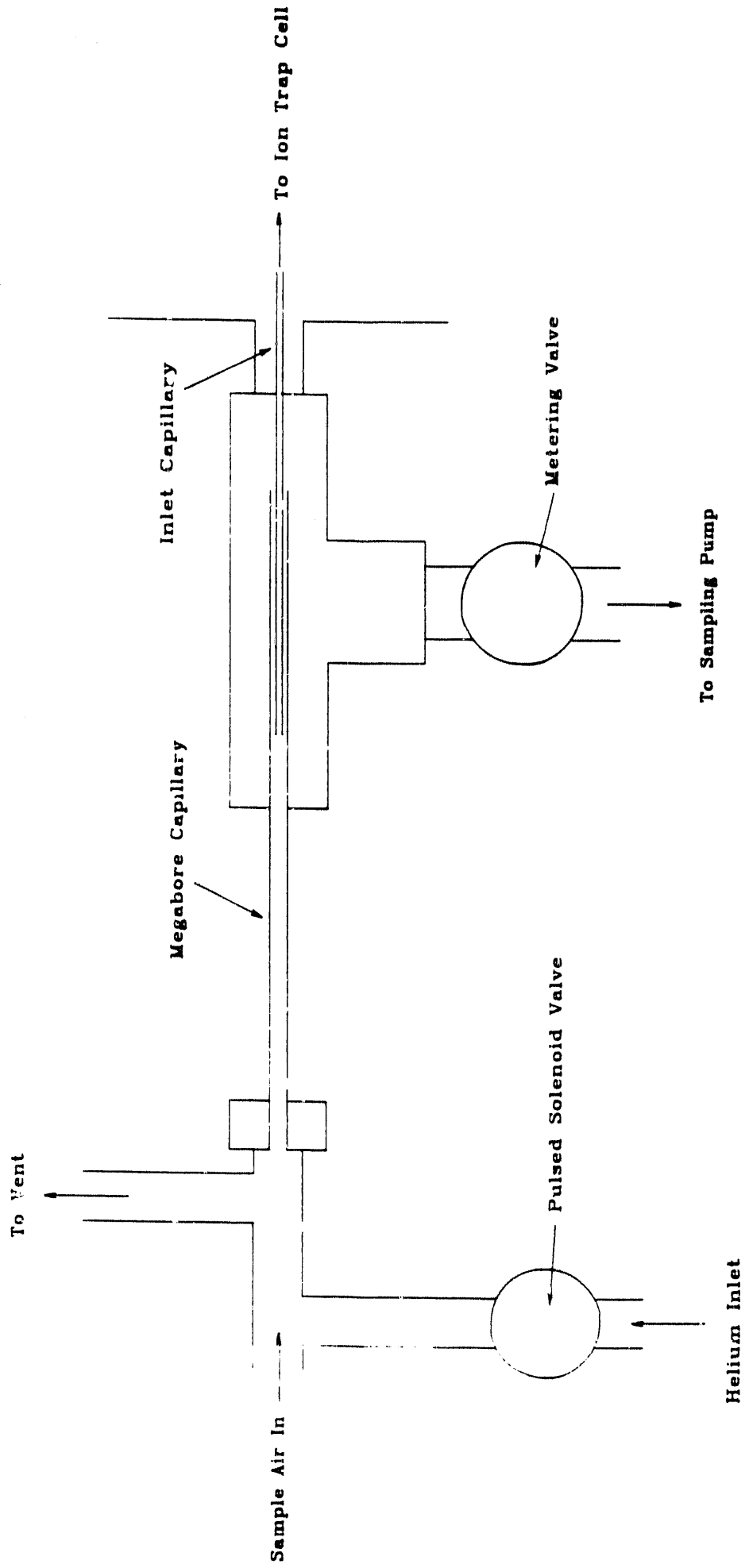

Figure 2 Split interface inlet for ITMS direct air monitoring.

ITMS SAMPLE INLET

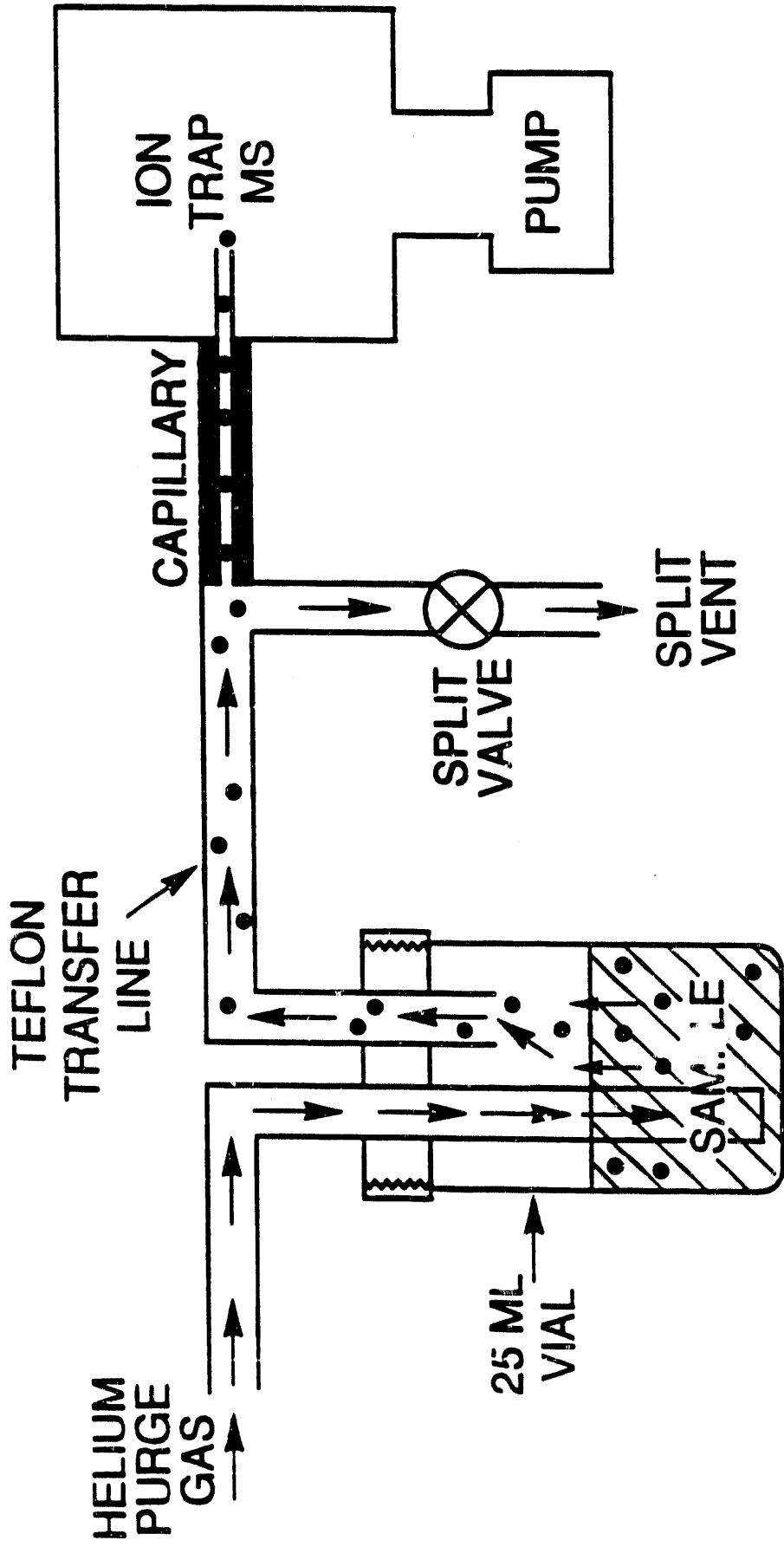

Figure 3 Device used for direct purging of volatiles from water and soil samples.

TANDEM SOURCE QUADRUPOLE MASS SPECTROMETER

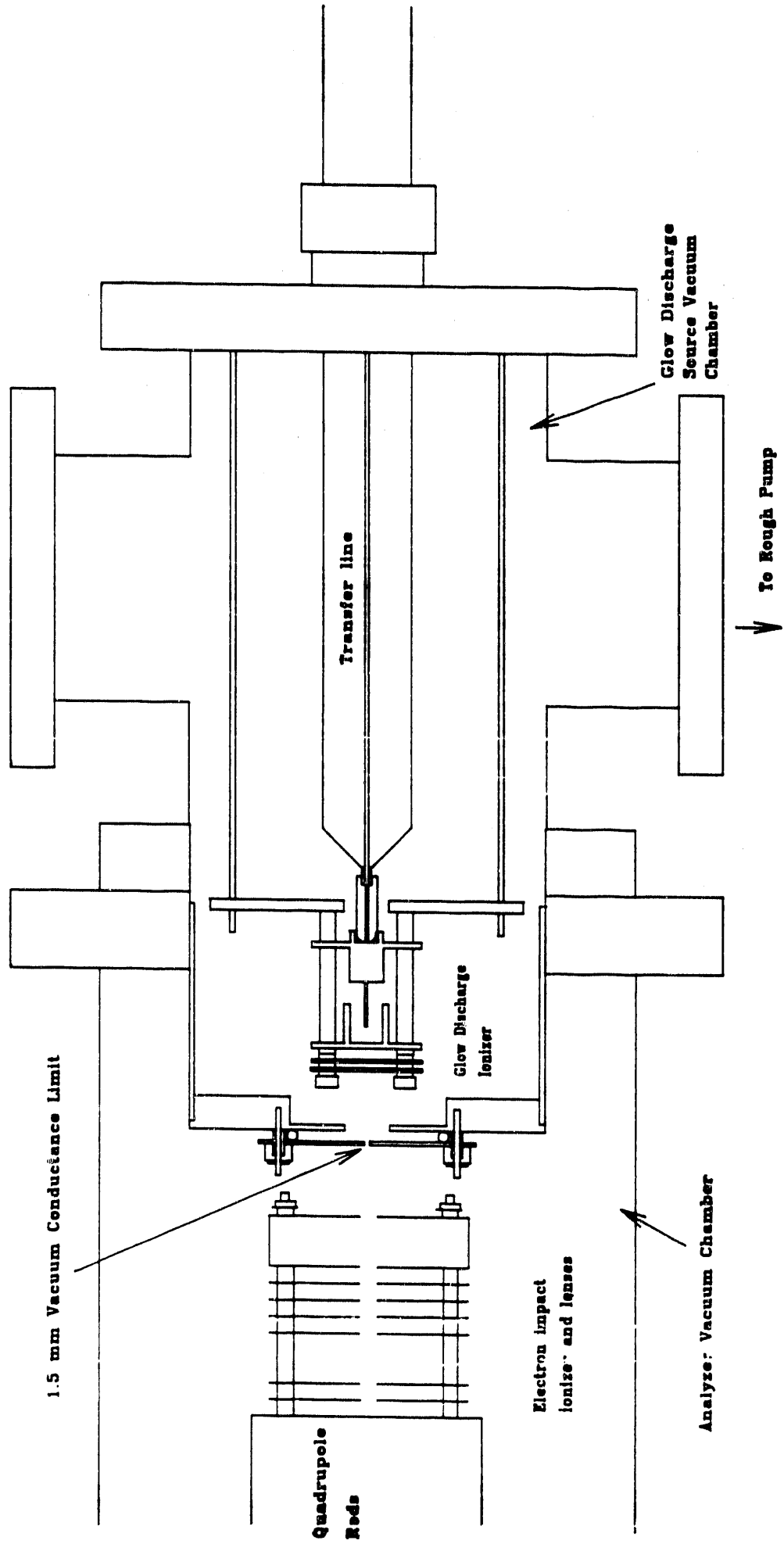

Figure 4 Diagram of the tandem source quadrupole mass spectrometer.

DYNAMIC SAMPLE GENERATING SYSTEM

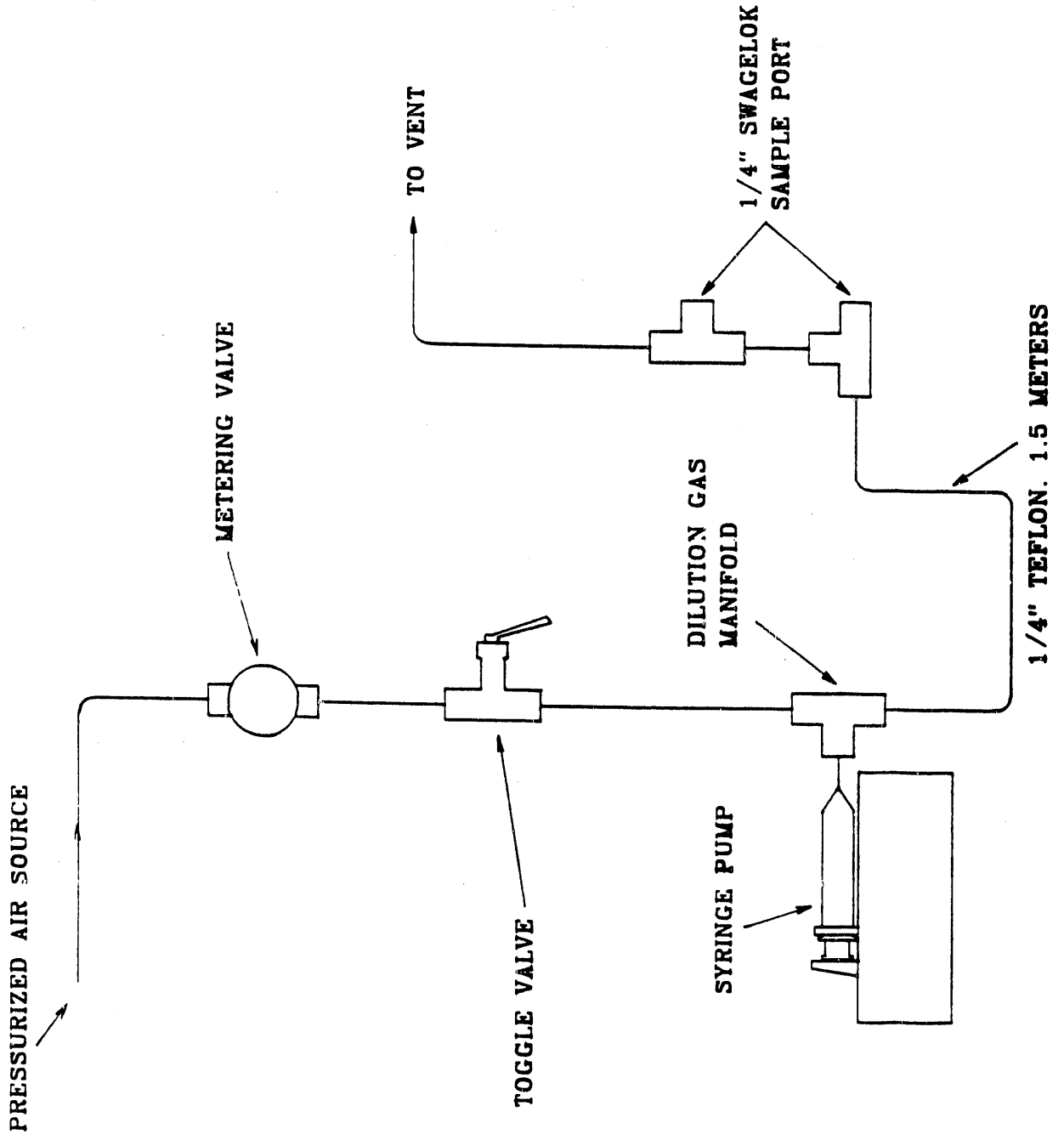

Figure 5 Schematic diagram of the dynamic sample generator.

Volatile Organics in Air

ITMS Direct Sampling

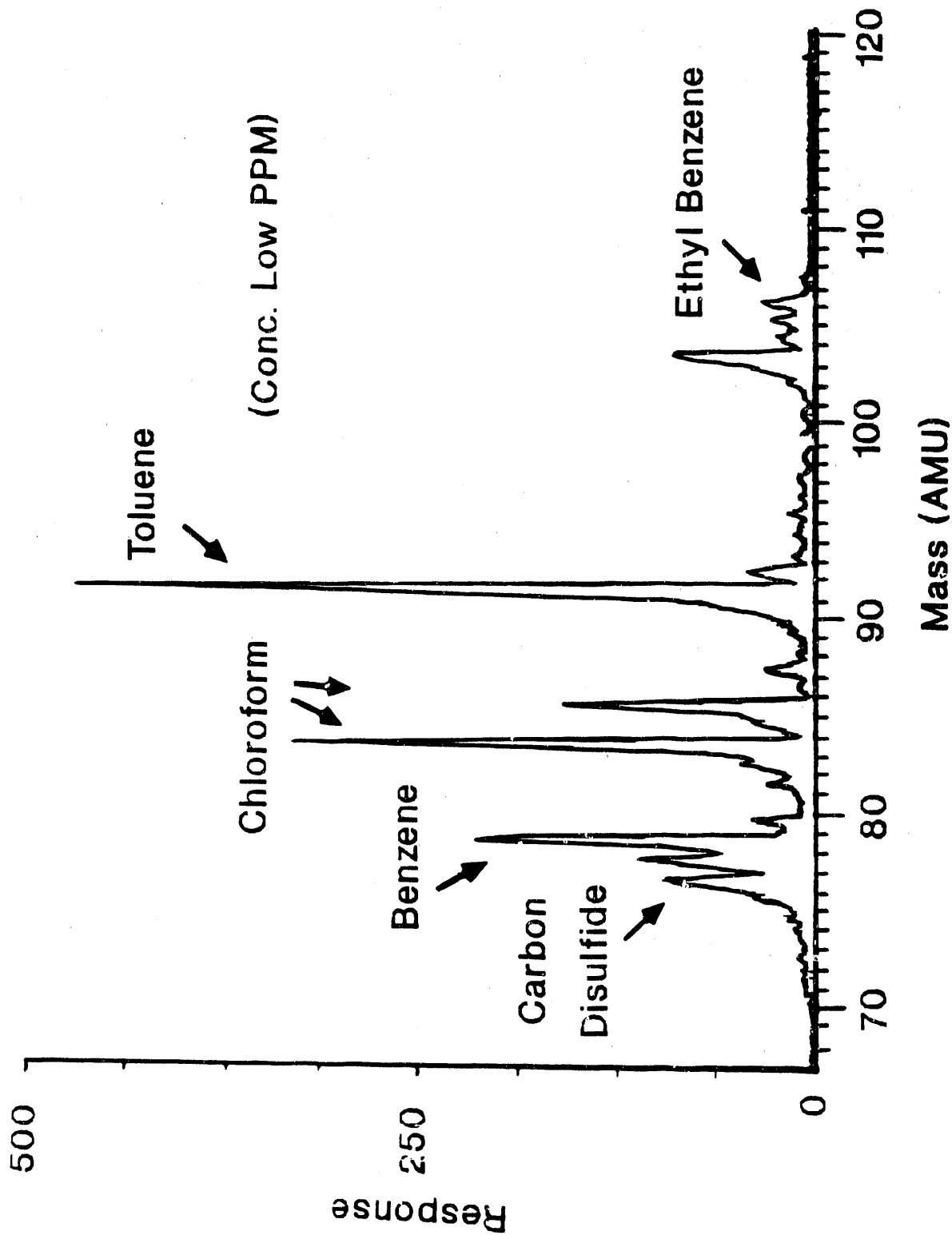

Figure 6 ITMS spectrum of a part-per-million mixture of volatile organics in air.

ITMS Response to Chloroform in Air

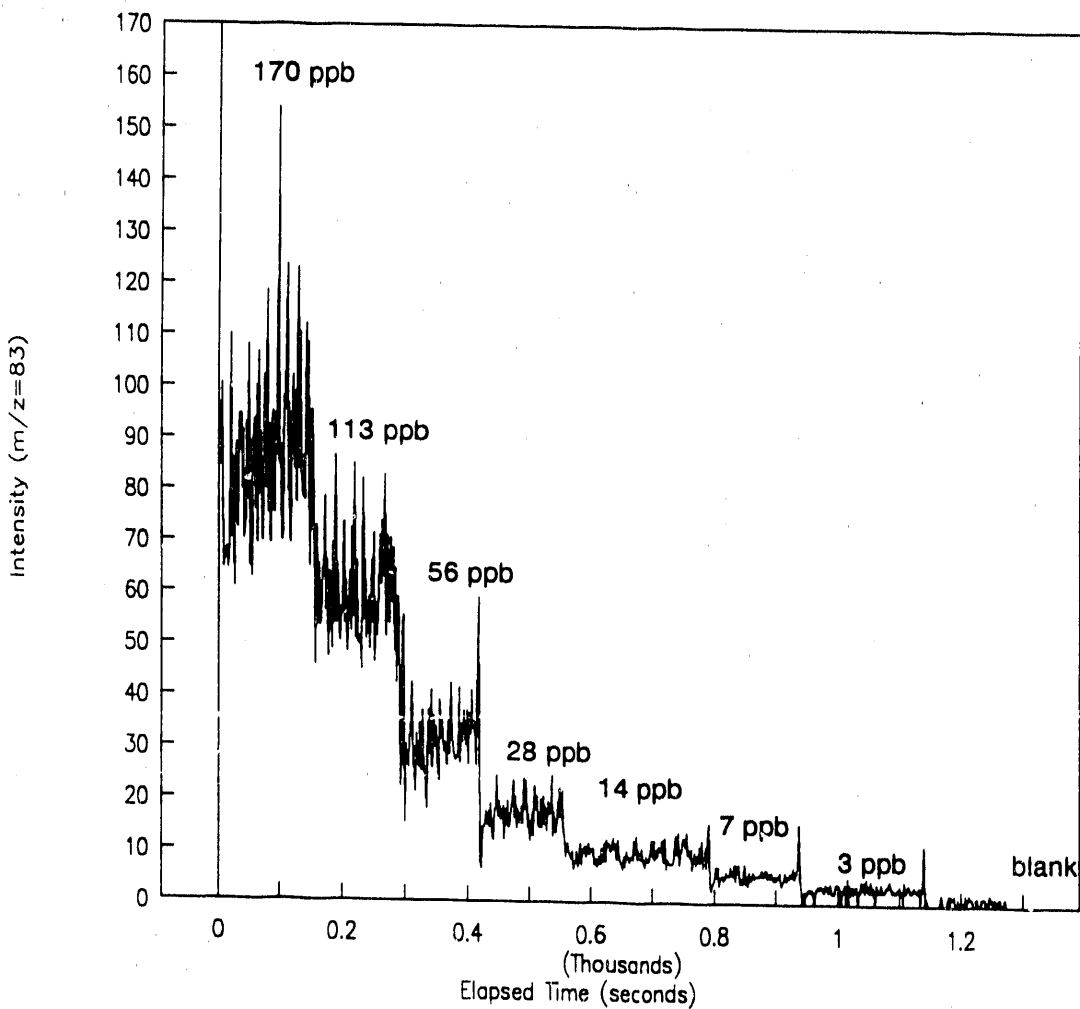

Figure 7 ITMS temporal response curve for various concentrations of chloroform in air.

Spectrum # 48 Filename: CHCL3 Acquired: Nov-07-1990 18:25:18 + 1:31
 Comment: chloroform in air, calibration curve from 1:1 MeOH/water
 Base Pk: 83 Int: 76 Range: 50-106 RIC: 198 100.00% = 76 AGC time: 50000

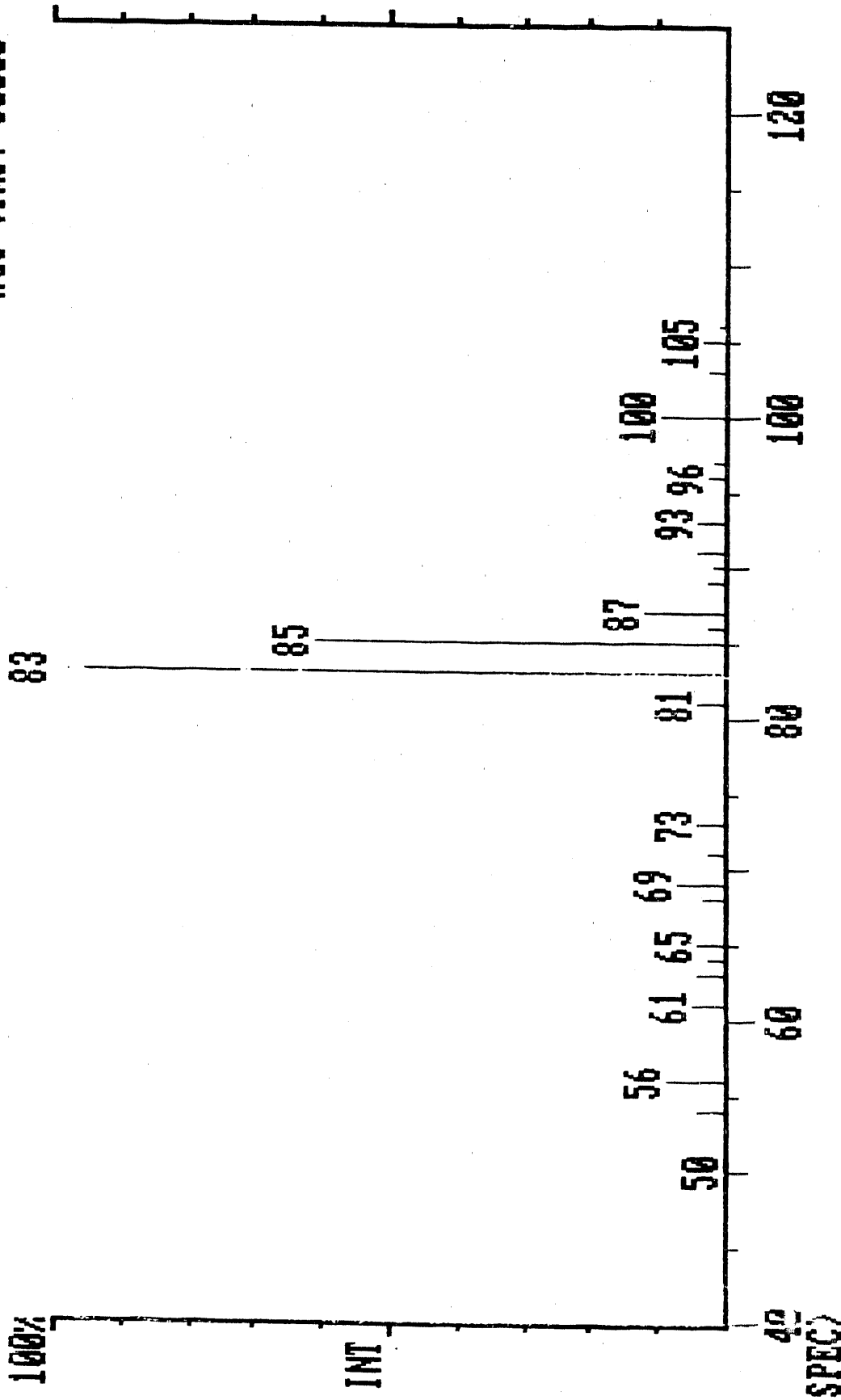

Figure 8 Post-processed spectrum of chloroform in air monitored using the ITMS.

Estimate of Tetrachloroethylene Detection Limit
Tandem-Source Quadrupole Detection

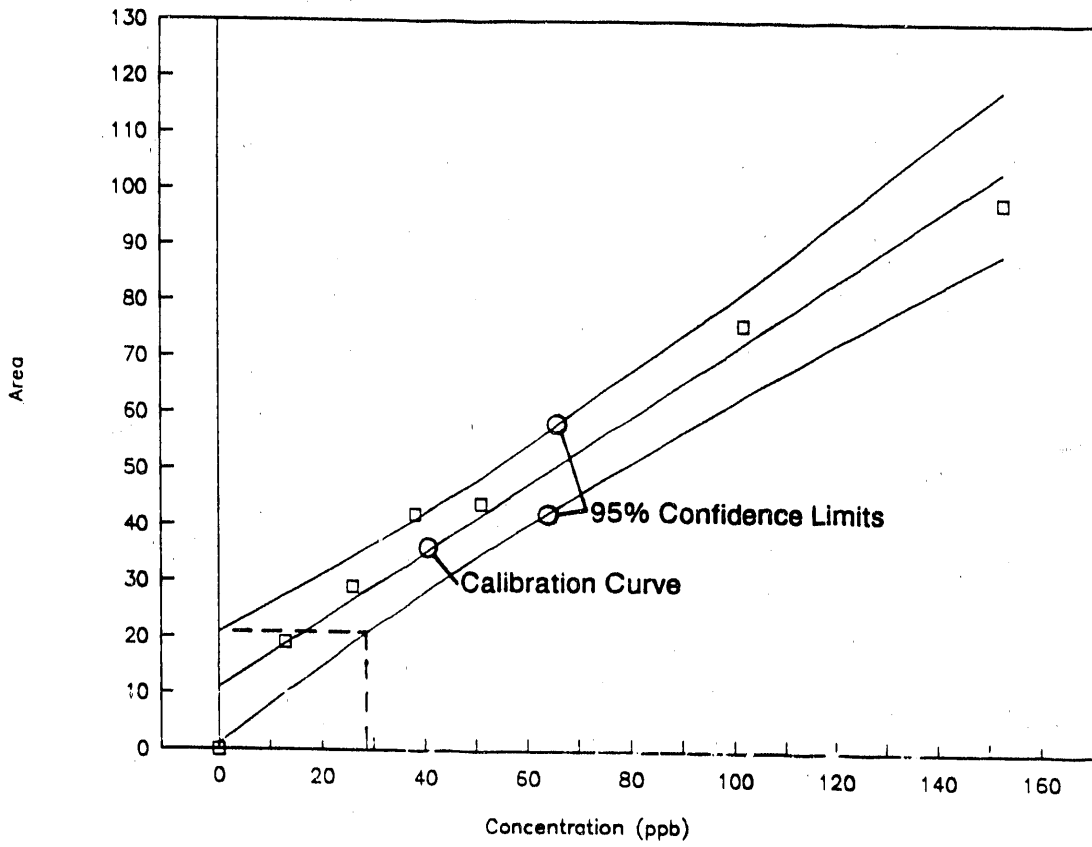

Figure 9 Graphical determination of detection limits for the TSMS instrument

BENZENE

Tandem Source Quadrupole Air Monitor

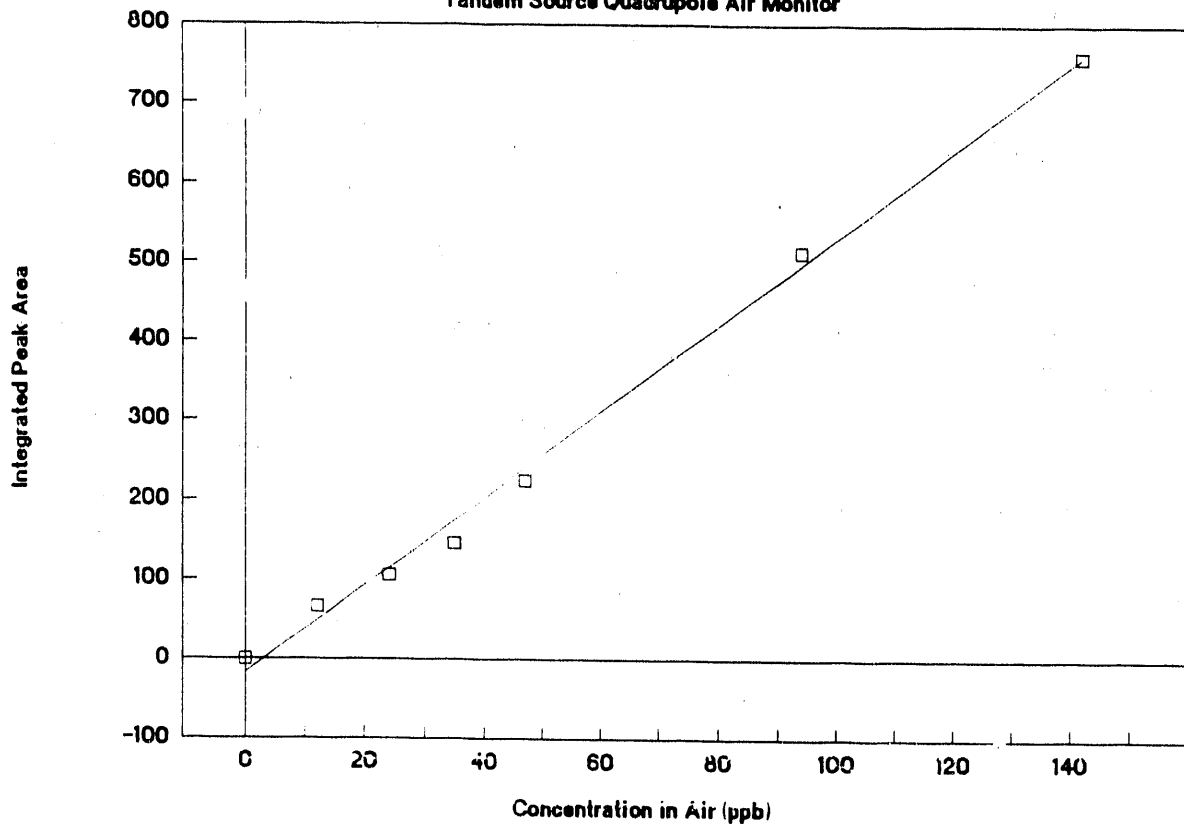

Figure 10 Calibration curve for benzene in air with tandem-source quadrupole detection.

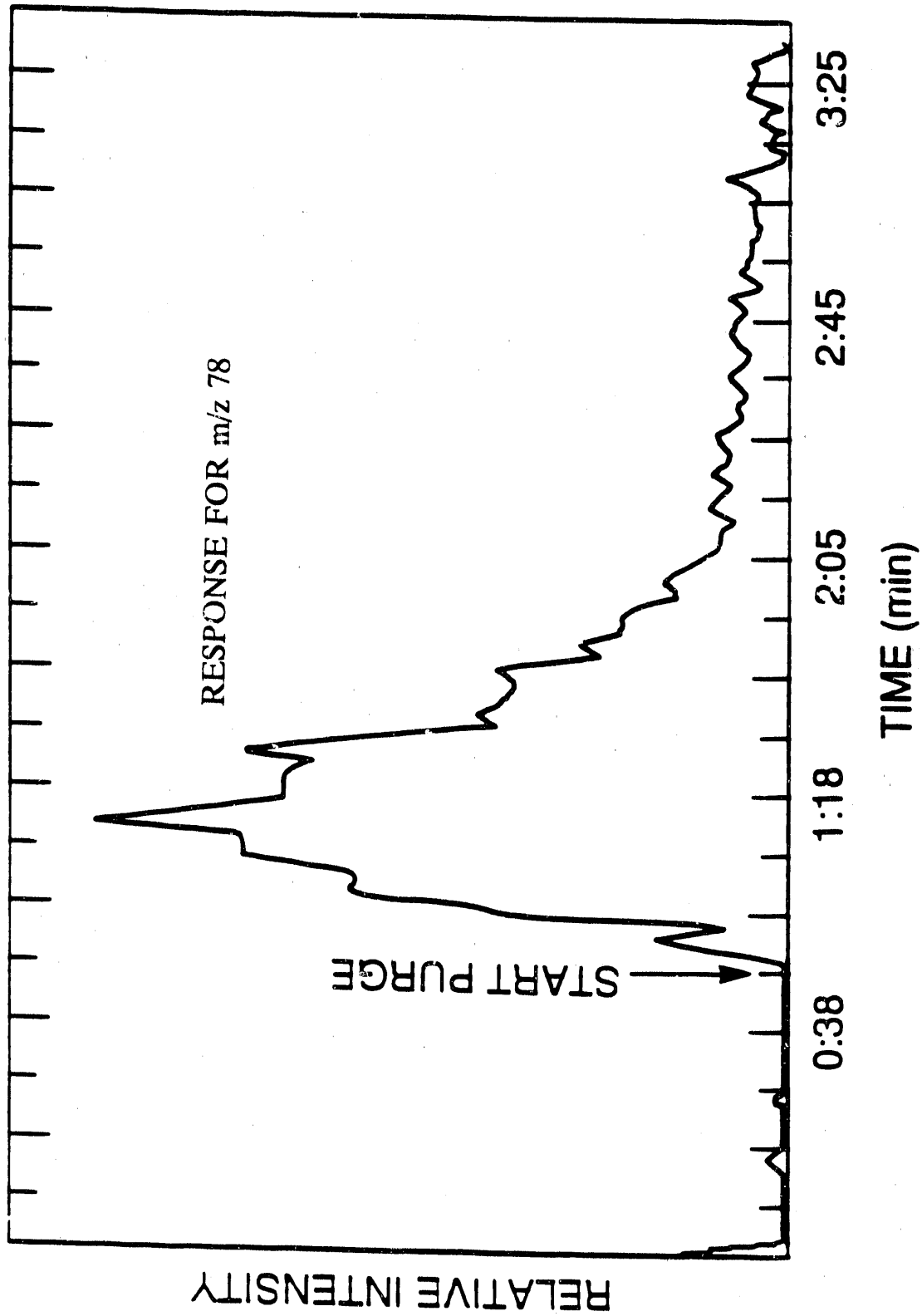

Figure 11 Reconstructed purge profile for 100 ppb of benzene in water.

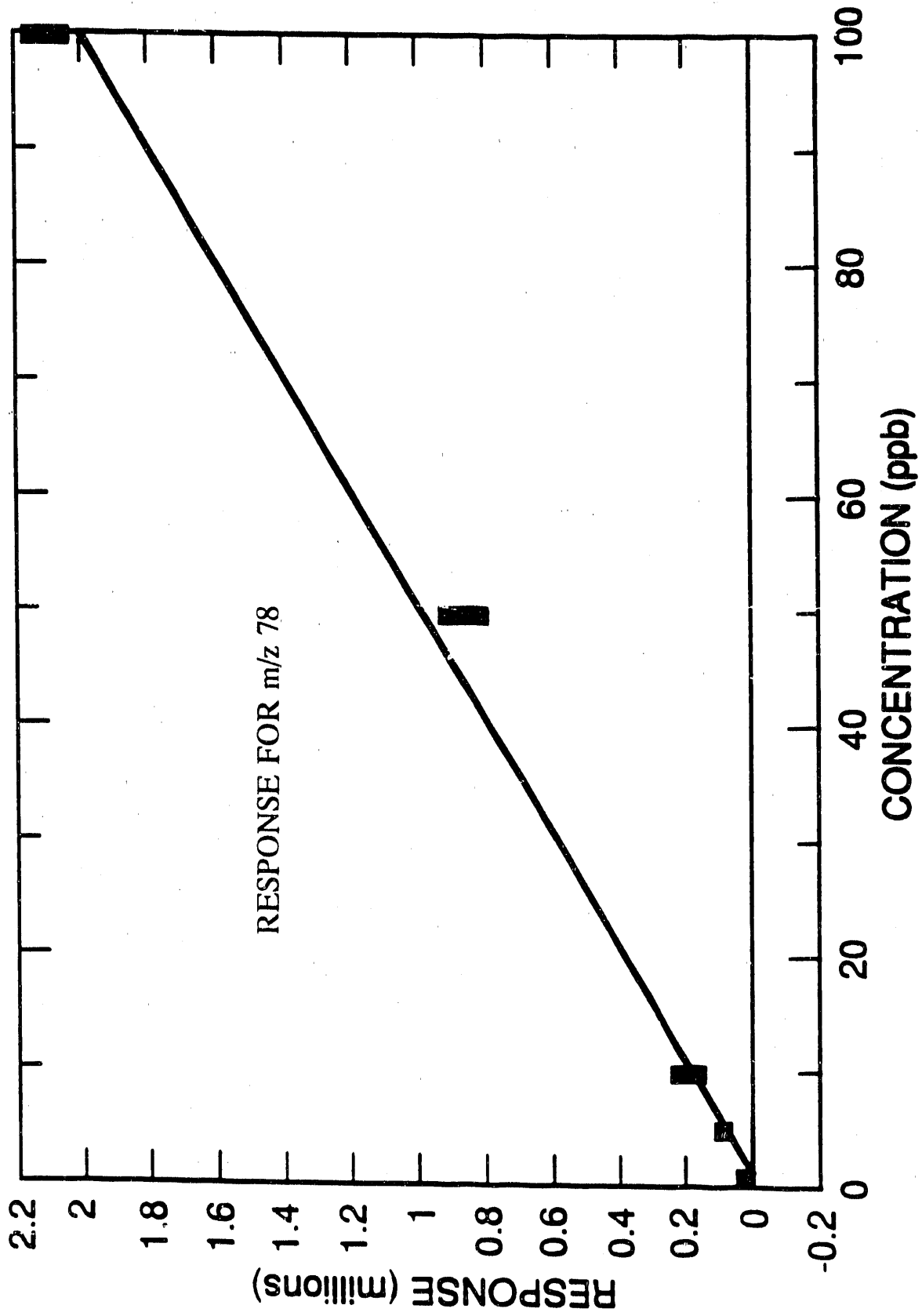

Figure 12 Calibration curve for the direct purge of benzene from water from 1 to 100 ppb.

SOLUTION PURGE PROFILES OF AQUEOUS VINYL CHLORIDE STANDARDS (ppb = ng/ml)

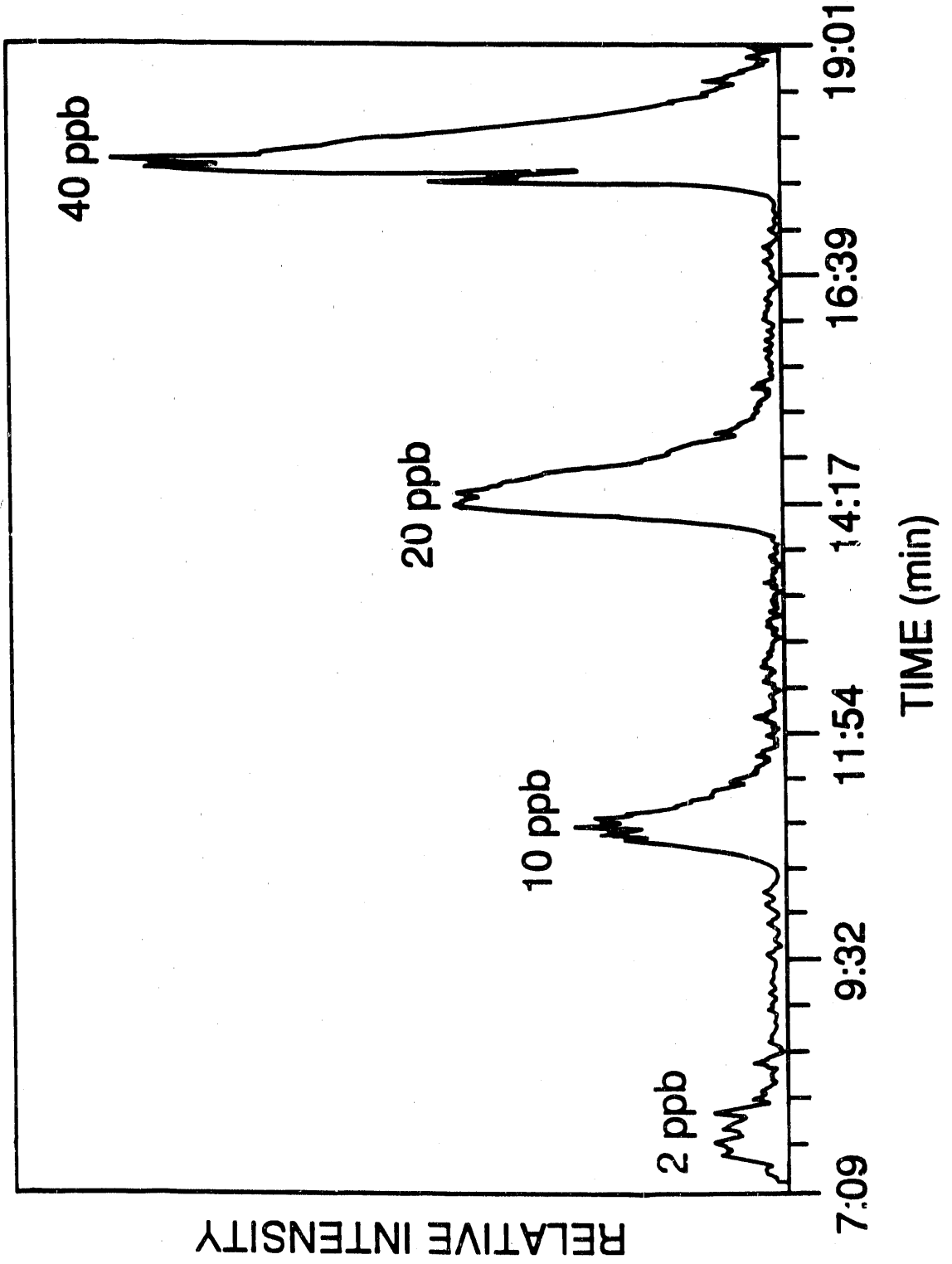
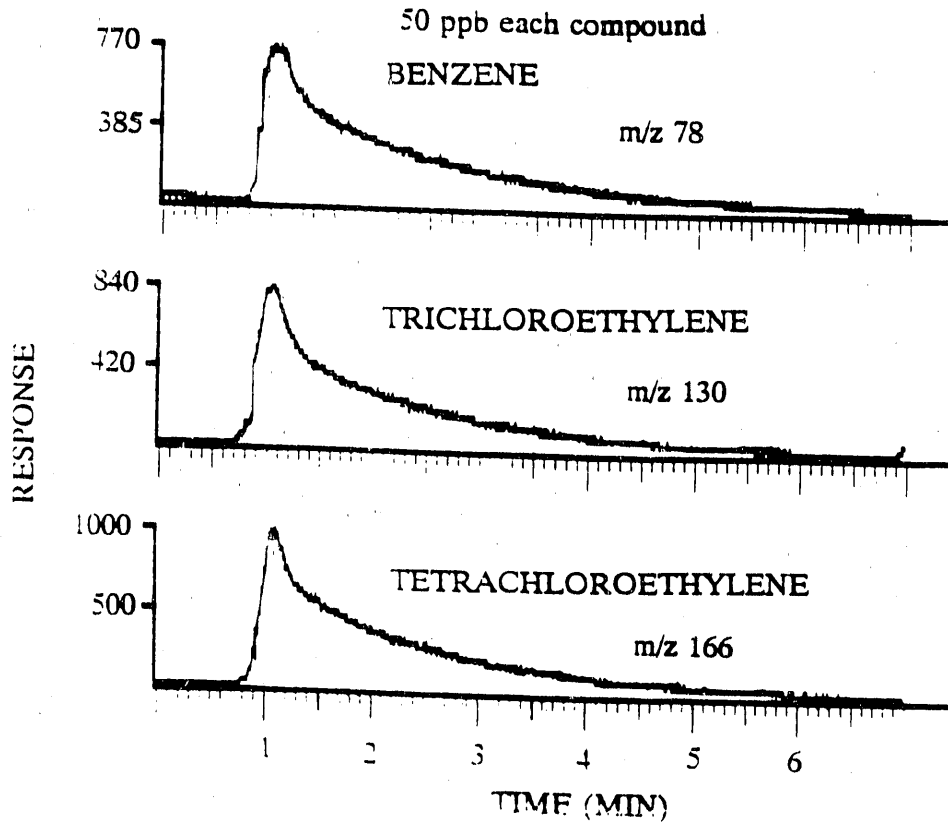

Figure 13 Direct purge profiles for 4 different concentrations of vinyl chloride in water.

VOLATILE ORGANICS PURGED FROM PH-2 WATER



VOLATILE ORGANICS PURGED FROM POTTING SOIL SLURRY

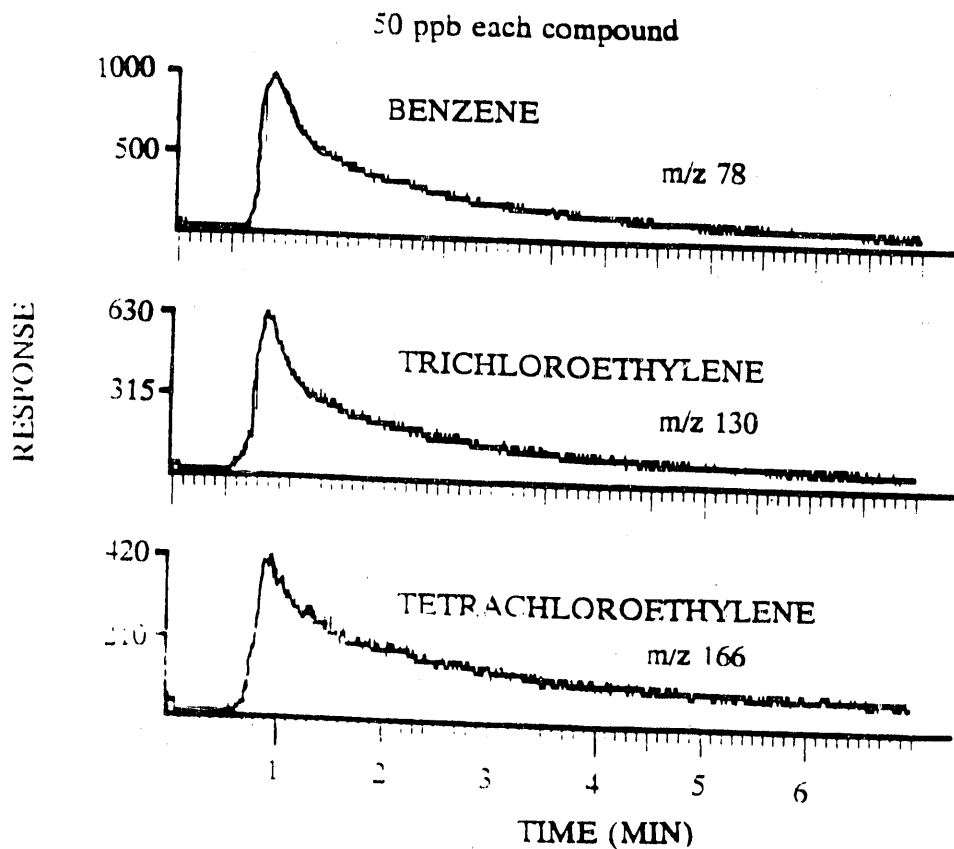

Figure 14 Comparison of VOC purge profiles for pH-7 water and potting soil slurry.

END

DATE FILMED

03 / 06 / 91