

UCRL- 96569
PREPRINTA LOW JITTER, LOW COST
TIME-OF-FLIGHT CIRCUITM. D. Cable
M. S. Derzon
R. G. Vieira
H. P. SpracklenThis paper was prepared for submittal to
the IEEE 1987 Nuclear Science Symposium,
San Francisco, California, October 21-23,
1987

October 1987

Lawrence
Livermore
National
Laboratory

This is a preprint of a paper intended for publication in a journal or proceedings. Since changes may be made before publication, this preprint is made available with the understanding that it will not be cited or reproduced without the permission of the author.

N. D. Cable, M. S. Derzon, and R. G. Vieira

DE88 001879

H. P. Spracklen, P.E., Consultant

University of California
Lawrence Livermore National Laboratory
P. O. Box 5508, Livermore, California

Abstract

A low cost circuit has been developed for use in a neutron time-of-flight spectrometer at the Nova Laser Facility. Using a silicon charged-particle detector, amplifier and constant-fraction discriminator, timing resolution of better than 50 ps FWHM has been achieved. Using an array of many such detectors, very high data rates and precise spectra can be obtained.

Introduction

In order to determine fusion fuel ion temperatures and fuel compression for Inertial Confinement Fusion (ICF), the energy distribution of fusion neutrons must be measured accurately. This energy distribution can be measured by neutron time-of-flight techniques which require a detector to record arrival times of the neutrons at the end of a known flight path. In our detector, the neutrons collide with a thin polyethylene sheet, elastically scattering protons. An array of small "single-hit" silicon detectors and circuitry with recovery times on the order of 5 ns can be used such that each records the arrival time of one neutron (proton flight path is negligibly small). An energy distribution is then constructed from which the ion temperature (θ_i) and fuel areal density ($\langle \rho R \rangle$) can be obtained. The θ_i is expressed as $\Delta E = 177 \sqrt{\theta_i}$, where ΔE is the FWHM energy spread of the primary 14 MeV neutron burst. Fuel areal density can be measured by obtaining detailed spectra of neutrons produced in

secondary fusion reactions which have energies significantly different from the primary neutrons.

Methods to obtain these quantities in the past have consisted of activation techniques or use of a single detector and oscilloscope with which it is impossible to unfold data with sufficient accuracy. Silicon strip detectors or small (5 mm x 5 mm) single detectors have the advantages of speed (low capacitance) and ability to detect single events.

The components to construct a large array of single detectors (individual detectors are referred to as "channels") need to be small and relatively inexpensive per channel. Silicon detectors, 1 GHz MMIC amplifiers, and an ECL compatible constant-fraction discriminator (CFD) have been designed in a small, economical configuration that achieves 35 ps (FWHM) timing resolution—quite adequate for accurate θ_i and $\langle \rho R \rangle$ measurements [1]. The signal is then run into a fast time-to-digital converter (TDC), and the arrival time is recorded relative to a common start trigger.

Description

The detector is a 5 mm x 5 mm x 270 μm piece of N-type silicon with a thin ion-implanted p-region. The 270 μm thickness was chosen as a compromise between signal rise time and the amount of energy that will be deposited in the detector as the charged particle passes through it.

* Work performed under the auspices of the U.S. Department of Energy by the Lawrence Livermore National Laboratory under contract number W-7405-ENG-48.

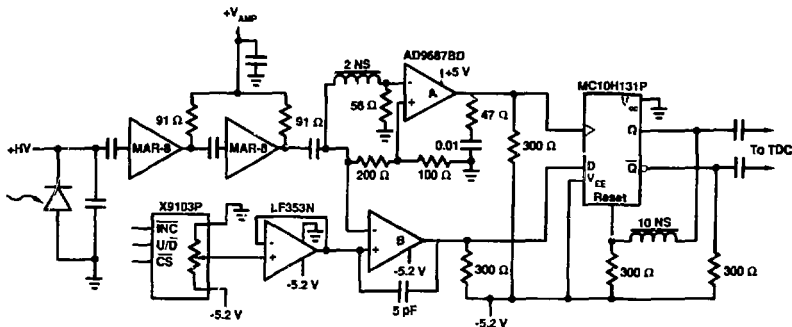

Figure 1. Time-of-flight circuit.

MASTER

DISTRIBUTION OF THIS DOCUMENT IS UNLIMITED



The amplifier section is comprised of 2 cascaded monolithic amplifiers, each having a theoretical gain of 21 dB and a 3.5 dBm noise figure--both at 1 GHz. They are 0.085" in diameter so a compact design can be achieved. Over an input range of between 0.5 and 6 MeV, the output of the combined amps yields 150 mV to 2.6 volts (see Fig. 1).

From the amplifiers, the signal is split to the constant-fraction discriminator (A) and to the gate comparator (B). The CFD is of standard design, using a 2 ns delay on one side and 33 percent attenuation on the other. The gate comparator is set for a threshold above the noise so as only to enable the flip-flop during a real event. This allows the CFD comparator threshold to be set at 0 volts.

Once enabled and then clocked, the flip flop is latched for > 10 ns before being reset as is required by the TDC (see Fig. 2). The TDC is stopped by this logic signal. Its common start input is generated from a Nova laser pickoff, and is therefore related to the time neutrons will emerge from an immoded ICF target. The time between the start and stop is recorded and read out via CAMAC--thus giving an absolute TOF for the incident neutron.

A digitally controlled circuit can be used to set the gate comparator's threshold. This is especially useful in large arrays.

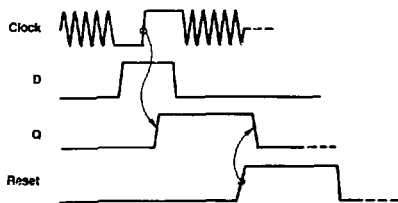

Figure 2. Timing Diagram at MC10H131P flip-flop.

Measurements

For initial testing, a laser light pulser was used for the input to the detector. A time-to-analog converter, together with a pulse height analyzer was used to check for timing jitter. The system resolu-

tion was < 3 channels (< 15 ps) FWHM. The light intensity was varied over a range of 825 keV to 5.8 MeV. With this system, 5 ps/channel time bins were achieved and a 7 + 1 channel FWHM spectrum was observed. This translates to 35 ± 5 ps timing resolution.

To measure absolute jitter with neutrons, another experiment is planned. By putting 2 detectors face to face, an energetic proton (10-12 MeV) will pass through both detectors, creating a signal in each. The second detector's signal will be used to start the TDC and the first used to stop it, thereby setting up a coincidence measurement to count only protons that pass through both detectors. Any system jitter will be cancelled, theoretically, if both signals are processed identically. This will then yield the true jitter in the circuit.

Cost

The cost of circuit components, including the detector, total about \$90 per channel. The TDC is about \$250 per channel. A further savings can be achieved by having several channels share a TDC channel. The cost of the PC board will vary dependent upon the number of channels per board.

Summary

A low cost, low jitter circuit has been designed and implemented achieving better than 50 ps FWHM timing resolution. The 35 ps FWHM measurement was done with a light pulser. We expect with neutrons to see this number degrade slightly due to the charge sweep-out time for the ionization track left by the proton (as opposed to surface ionization for the light pulser).

This approach can also be used to achieve very high data rates at accelerators because the data would be collected in parallel from many inexpensive channels. Then, using a high throughput bus architecture such as FASTBUS to move the collected data, rates could increase to many times the maximum achievable with a single detector.

References

- [1] M. O. Cable, S. P. Hatchett, J. Appl. Phys., **62**, p. 2733 (1987).
- [2] M. O. Cable, J. Appl. Phys., **60**, p. 3068 (1986).
- [3] H. Spieler, IEEE Trans. Nucl. Sci. NS-29, p. 1142 (1982).

DISCLAIMER

This report was prepared as an account of work sponsored by an agency of the United States Government. Neither the United States Government nor any agency thereof, nor any of their employees, makes any warranty, express or implied, or assumes any legal liability or responsibility for the accuracy, completeness, or usefulness of any information, apparatus, product, or process disclosed, or represents that its use would not infringe privately owned rights. Reference herein to any specific commercial product, process, or service by trade name, trademark, manufacturer, or otherwise does not necessarily constitute or imply its endorsement, recommendation, or favoring by the United States Government or any agency thereof. The views and opinions of authors expressed herein do not necessarily state or reflect those of the United States Government or any agency thereof.

MASTER