

UCRL--93834

DE86 008026

TI

DETERMINING PLASMA-FUELING SOURCES
WITH AN END-LOSS ION SPECTROMETER

D. P. Grubb
J. H. Foote

This paper was prepared for submittal to the
Proceedings of the 6th Topical Conference on
High Temperature Plasma Diagnostics, American
Physical Society, Hilton Head Island,
South Carolina, March 9-13, 1986.

March 4, 1986

Lawrence
Livermore
National
Laboratory

This is a preprint of a paper intended for publication in a journal or proceedings. Since changes may be made before publication, this preprint is made available with the understanding that it will not be cited or reproduced without the permission of the author.

MASTER

DISTRIBUTION OF THIS DOCUMENT IS UNLIMITED

DETERMINING PLASMA-FUELING SOURCES
WITH AN END-LOSS ION SPECTROMETER

D. P. Grubb and J. H. Foote

Lawrence Livermore National Laboratory, University of California

P.O. Box 5511, Livermore, CA 94550

ABSTRACT

To help identify the major sources of fueling gas in Tandem Mirror Experiment-Upgrade (TMX-U), we mounted a mass-sensitive, $E||B$, end-loss ion spectrometer (ELIS) near the machine's centerline. We set the electric field in the ELIS to simultaneously measure the axial loss currents of both hydrogen and deuterium. We then initiated plasma discharges, where we injected either hydrogen or deuterium gas into the central cell. We also selected and deselected the central-cell neutral beams that were fueled with hydrogen gas. The end-cell neutral beams were always selected and fueled with deuterium. By taking the ratio of the hydrogen end-loss current to the deuterium end-loss current (with a known deuterium-gas feed rate), we were able to infer the effective fueling rates that were due to wall reflux, central-cell beams, and end-cell beams. The results were the following: wall reflux, 6 Torr·l/s; central-cell beams, 15 Torr·l/s; and end-cell beams 1 Torr·l/s.

I. E||B END-LOSS ION SPECTROMETER

Charged particles that enter a region of parallel electric (\vec{E}) and magnetic (\vec{B}) fields at coordinate (0,0,0) with momentum (0,0,mV_z) are separated by their momentum in a plane perpendicular to \vec{E} and \vec{B} and by their charge-to-mass ratio in the direction of \vec{E} and \vec{B} (Fig. 1). The governing equations are

$$x = 2\sqrt{2mW}/qB_y \quad (1)$$

and

$$y = \pi^2 m E_y / (2q B_y^2) \quad (2)$$

where m is the particle's mass, q its charge, and W its energy ($W = \frac{1}{2} mV_z^2$). E_y is the analyzer's electric field and B_y is its magnetic field (both of which are in the y direction). By placing parallel strips of particle detectors in the x direction, we can simultaneously analyze the momentum (energy) of ion species with different charge-to-mass ratios. This principle has been used by Medley at Princeton¹ and by Armentrout at General Atomic² to create neutral-flux (charge-exchange) analyzers and by Foote at Livermore to create an end-loss ion spectrometer.³

For this experiment, we mounted the ELIS near the radial centerline of TMX-U on the east end wall. We equipped the ELIS with two parallel strips of Faraday cup detectors so that the flux of both hydrogen and deuterium ions could be measured. We used a dedicated microcomputer system to collect

the raw data and to determine the end-loss ion-current density, the peak plasma potential, and the average energy of the end-loss ions for both hydrogen and deuterium.³

II. EXPERIMENT

Figure 2 schematically shows the axial variation of the magnetic field in TMX-U. The locations of the principal heating and fueling systems are also shown in this figure. The primary gas-fueling source is the central-cell (CC) gas box. This is a closed structure around the radial edge of the plasma into which we meter neutral gas using piezoelectric valves. The neutral beams shown in both end cells and in the central cell are 15-kV, 50-A Berkeley type injectors (Fig. 2). In this paper, we refer to the beam current only in terms of the accelerated current, drained from the beam power supply.

Note that TMX-U is a heavily gettered system where approximately 10 A of titanium gettering are sublimated onto the walls of the device before each plasma discharge.

From these experiments, we wished to determine whether or not the central cell was the dominant source of end-loss ions, how much of our particle fueling was due to wall reflux, and how much fueling was provided by the central-cell beams.

We determined the desired quantities by using the ELIS to measure the ion axial-loss current densities of hydrogen and deuterium (near the axis of the device) as a function of the sources and types of particle fueling.

We began the experiment by fueling the central cell with deuterium gas. The end-cell neutral beams were also fueled with deuterium (these beams

remained unchanged throughout the experimental sequence.) After a series of these discharges, we added the central-cell neutral beams, which were fueled with hydrogen gas. Typical data from the second series of discharges are shown in Fig. 3. For the last series, we switched to injecting hydrogen into the central-cell gas box.

The results of these experiments are given in Table 1.

III. DISCUSSION

The values in Table 1 are presented as effective, on-axis, fueling rates because (1) the ELIS measurements were made within 2 cm of the axis of the device (measured in the central cell), and (2) the ratio of the ion axial-loss currents is the ratio of the neutral-hydrogen-fueling rate to the neutral-deuterium-fueling rate, assuming (i) that both gases had undergone the same amount of radial attenuation while reaching the axis, (ii) that there was no preferential radial transport of hydrogen or deuterium, and (iii) that there was no preferential loss of hydrogen or deuterium out either end of the device.

During the initial series of discharges, when we did not fuel with hydrogen gas, we still obtained an effective hydrogen-gas fueling rate of 6 Torr·l/s. This is unusual for TMX-U. During typical TMX-U operation with only deuterium gas feed, the hydrogen end losses measured by the ELIS are zero. We believe that the large hydrogen signal is due to the fact that we had loaded the central-cell walls with hydrogen earlier in the day while we conditioned the central-cell beams to run on hydrogen. We believe, therefore, that the central-cell walls were the primary source of hydrogen during the first series of discharges.

It is interesting to compare the above data to that taken when all the fueling (except the end cells) was done with hydrogen. For this case, the total deuterium fueling was equivalent to 1 Torr·l/s. Since this value is equal (within a factor of 2) to the trapped beam current in the end cells, it is possible that the total wall reflux fueling was zero, which appears to contradict our earlier measurement with hydrogen wall reflux. We can offer two possible explanations: either one of our assumptions about hydrogen vs deuterium fueling is wrong, or the primary source of wall-reflux fueling is in the area of the central-cell neutral beams.

We also note that the hydrogen fueling rate from the central-cell neutral beams is large: 13 to 17 Torr·l/s. Since the maximum amount of axial-loss current that would result from direct trapping of energetic beam neutrals is less than 1 Torr·l/s, we conclude that the remainder is due to streaming-gas and beam-dump reflux gas. This observation is consistent with the slow increase in the hydrogen end-loss signal after the beams are turned on (Fig. 2).

Lastly, we report that the change from equal deuterium-to-hydrogen end losses to almost entirely hydrogen end losses was observed on the very first shot after we switched from deuterium to hydrogen gas feed in the central-cell gas box. We attribute this quick change over to having a heavily gettered system such that the walls did not require reconditioning after a source-gas change.

Based on this experiment, we conclude that a mass-sensitive ion spectrometer is a valuable tool for determining the fueling sources in an open-ended device such as a tandem mirror. Preliminary experiments with this instrument in TMX-U indicate that neutral-gas and neutral-beam fueling in the central cell does provide the primary source of particles that eventually escape out the ends of the device. Wall-reflux fueling is smaller than the other sources and also seems to be concentrated in the central cell.

ACKNOWLEDGMENTS

The authors would like to acknowledge the contributions made to this paper by S. Allen, L. Berzins, C. Burdett, T. Casper, C. Damm, A. Futch, A. Hunt, R. Jong, W. Meyer, W. Pickles, and G. Porter, all of whom participated in the planning and execution of this experiment. This work was performed under the auspices of the U.S. Department of Energy by the Lawrence Livermore National Laboratory under Contract No. W-7405-ENG-48.

Table 1. Effective, plasma fueling rates as a function of gas sources.

Hydrogen sources	Deuterium sources	Effective hydrogen-fueling rate (Torr·l/s)
● Wall reflux	Wall reflux, central-cell gas at 70 Torr·l/s, end-cell beams: 380 A	6 ± 1.8
● Wall reflux, central-cell beams: 110 A	Wall reflux, central-cell gas at 70 Torr·l/s, end-cell beams: 325 A	23 ± 1.2
● Wall reflux, central-cell beams: 100 A	Wall reflux, central-cell gas at 20 Torr·l/s, end-cell beams: 300 A	18 ± 5.9
● Wall reflux, central-cell beams: 110 A, central-cell gas at 20 Torr·l/s	Wall reflux, end-cell beams: 250 A	Effective deuterium-gas fueling rate: 1 ± 0.33

REFERENCES

- ¹S. S. Medley and R. Kaita, Bull. Am. Phys. Soc. 24, 933 (1979).
- ²C. Armentrout, G. Bramson, and A. Lieber, Bull. Am. Phys. Soc. 25, 960 (1980).
- ³J. H. Foote, B. E. Wood, M. D. Brown, and C. M. Curnow, "Plasma Measurements with the TMX-U E|B End-Loss-Ion Spectrometers," proceedings this conference.

FIGURE CAPTIONS

Fig. 1. Schematic of an $E||B$ charged-particle analyzer. The actual device was mounted on the east end wall of TMX-U, where it analyzed the energy distribution of ions that escaped axially along the magnetic field to the end wall.

Fig. 2. Axial profile of the magnetic-field strength in TMX-U. Locations of primary heating and fueling sources are shown. Also indicated is the type of gas (D_2 or H_2) used in the particle-fueling sources.

Fig. 3. Typical data from a plasma discharge that was fueled with deuterium gas in the central-cell gas box (20 Torr·l/s), with deuterium gas in the end-cell neutral beams (300 accel. A), and with hydrogen central-cell beams (100 accel. A). Shown are the time histories of (a) the central-cell density from microwave interferometry, (b) and (c) the axial-loss currents (integrated over energy) of deuterium and hydrogen ions, respectively, from the ELIS, and (d) the axial-loss current measured by a Faraday cup mounted on the TMX-U end wall near the ELIS.

Grubb and Foote - Figure 1

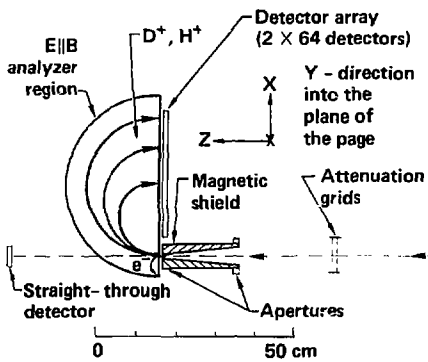

Grubb and Foote - Figure 2

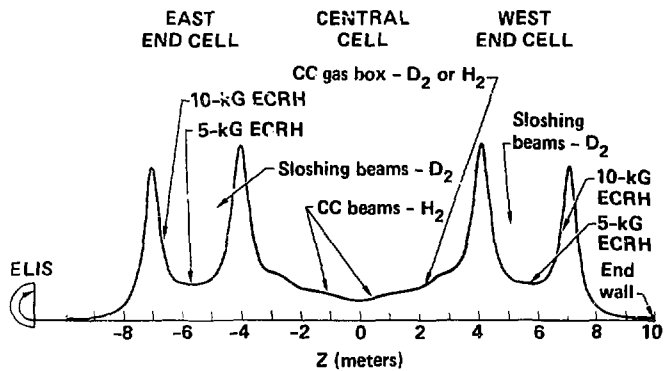

Grubb and Foote - Figure 3

