

MASTER

UCRL-83928
PREPRINT

CONF-800427--11

TRITIUM MANAGEMENT IN FUSION
SYNFUEL DESIGNS

T. R. Galloway

This paper was prepared for submittal to the
ANS National Topical Meeting, April 28-May 1, 1980,
Dayton, Ohio.

April 25, 1980

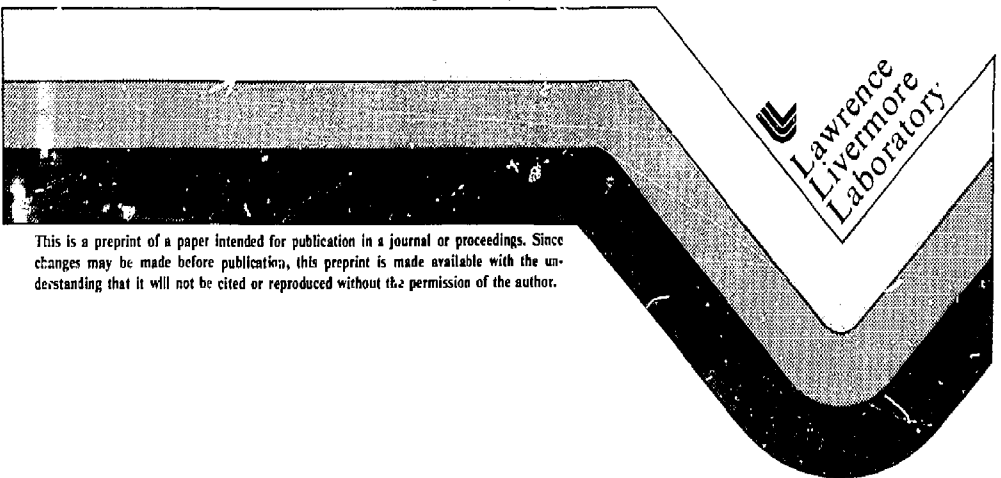

This is a preprint of a paper intended for publication in a journal or proceedings. Since changes may be made before publication, this preprint is made available with the understanding that it will not be cited or reproduced without the permission of the author.

DISTRIBUTION OF THIS DOCUMENT IS UNLIMITED

DISCLAIMER

This book was prepared as an account of work sponsored by an agency of the United States Government. Neither the United States Government nor any agency thereof, nor any of their employees, make any warranty, express or implied, or assume any legal liability or responsibility for the accuracy, completeness, or usefulness of any information, apparatus, product, or process disclosed, or represents that its use would not infringe privately owned rights. Reference herein to any specific commercial product, process, or service by trade name, trademark, manufacturer, or otherwise, does not necessarily constitute or imply its endorsement, recommendation, or favoring by the United States Government or any agency thereof. The views and opinions of authors expressed here do not necessarily state or reflect those of the United States Government or any agency thereof.

TRITIUM MANAGEMENT IN FUSION FUEL DESIGNS*

Terry R. Gallaway

Chemical Engineering Division
Lawrence Livermore Laboratory, University of California
Livermore, California 94550

ABSTRACT

This year we have begun a new program at Lawrence Livermore Laboratory (LLL) on synfuels from fusion, in collaboration with the University of Washington and Exxon Nuclear. In this program, we are designing a fusion blanket that can provide the heat and be efficiently interfaced to any one of three therm chemical cycles that have been demonstrated in a closed-loop pilot scale. Two blanket types are being studied: a lithium-sodium pool boiler and a lithium-oxide- or aluminate-microsphere moving bed. For each we have considered a wide variety of current technology in handling the tritium. Here, we show the pool boiler with the sulfur-iodine thermochemical cycle first developed and now being piloted by the General Atomic Company. The tritium (T_2) will be generated in the lithium-sodium mixture where the concentration is ~ 10 ppm and held constant by a scavenging system consisting mainly of permeators. An intermediate sodium loop carries the blanket heat to the thermochemical cycle, and the T_2 in this loop is held to 1 ppm by a similar scavenging system. With this design, we have maintained blanket inventory at 1 kg of tritium, kept thermochemical cycle losses at 5 Ci/d and environmental losses to 10 Ci/d, and held total plant risk inventory at 7 kg tritium.

INTRODUCTION

The production of synthetic fuels will be of increasing importance in the coming decades, as more acute shortages of transportable fuels occur. In the past, the fusion community has focused on power plants for electric power production. In addition to future electrical power plants being fusion based, we need to develop and examine a variety of synthetic fuel production concepts for which a fusion energy source may be used. The Tandem Mirror Reactor (TMR) is an emerging engineering design concept for fusion energy based on Lawrence Livermore Laboratory (LLL) tandem mirror physics now being developed.

The coupling of a TMR to one of three thermochemical cycles is being studied under a new Department of Energy (DOE) contract at LLL entitled, "Synfuels From Fusion." In this design study, we are taking unique advantage of the favorable engineering features of the Tandem configura-

tion that is a simple, cylindrical-solenoidal, energy-producing section between end cells. The end cells provide the containment. The central-cell solenoid contains modular blanket sections that produce both high-temperature process heat (950°C) and the required tritium to run the DT reactor. Material and engineering structural problems are minimized by the geometry, steady state temperature, and magnetic field.

Two tandem mirror blanket concepts are being explored: a lithium-sodium liquid-metal pool boiler and a lithium-oxide-microsphere moving bed. Three thermochemical cycles are being examined to reveal their specific advantages or disadvantages in interfacing with the TMR: the General Atomic sulfur-iodine cycle; the Westinghouse sulfur cycle; and the International Atomic Energy Agency at Ispra, Italy, Mark 13-V2 cycle. Here, we describe the approach for handling tritium in the fusion reactor in connection with the General Atomic sulfur iodine process.

THE LITHIUM-SODIUM CAULDRON BLANKET DESIGN

The original cauldron blanket concept of Lee (1-3), linked to the present TMR geometry, allows us to surround the plasma with a sealed vessel containing a binary mixture of 60% lithium and 50% sodium. This simple pool boiler is shown in Figure 1. The plasma energy input heats the fluid mixture and causes the sodium to preferentially vaporize. The vapor pressure of lithium and sodium at 1200 K are 0.02 and 1.5 atm, respectively (4), a difference of 75 times. The lithium is left behind in the liquid state to breed tritium. Lithium alone could not be used because unreasonably high vapor velocities would be necessary to carry the heat away. The sodium vapor, transporting energy as latent heat, condenses on heat exchange tubes that are outside of the magnetic field zone and are therefore free from magnets hydrodynamic effects. Energy is then transferred from the condensing-vapor heat exchanger to sodium coolant. This is accomplished by heat transfer fluid in an intermediate loop that carries the heat outside the nuclear island to the myriad process exchangers within the thermochemical hydrogen-production cycle.

In the cauldron, the lithium and sodium are completely miscible and a circulation pattern is

* Work performed under the auspices of the U.S. Department of Energy by the Lawrence Livermore Laboratory under contract number W-7405-Eng-48.

Reference to a company or product name does not imply approval or recommendation of the product by the University of California or the U.S. Department of Energy to the exclusion of others that may be suitable.

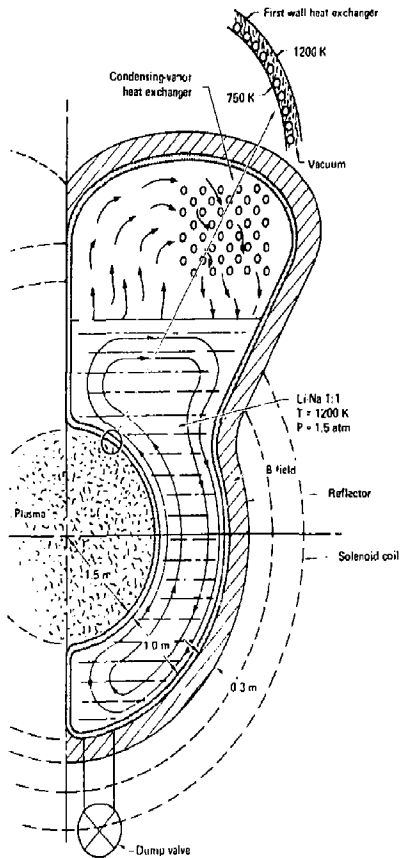

Figure 1. Lithium-sodium cauldron pool boiler design

established by two effects: the exponential decrease in energy deposition in the blanket as a function of radius, creating a temperature and density gradient; and the density difference between liquid sodium and lithium. Additional means to drive the circulation are provided by sparging with helium gas.

The structural container for this hot, 1200-K fluid mixture is actually held at a temperature of 700 to 750 K so that a significant ΔT is introduced across the first wall. This is accomplished by providing a compressively loaded membrane on the hot side, and heat exchanger tubes on the cool side. Sandwiched in between is a metallic sponge with a low thermal conductivity value, perhaps 10% that of common metals. The thickness of this sponge is a design parameter and can be set somewhat at our discretion, probably ~2 cm. About a 40% void fraction of interconnected pores is selected so that a controllable mass flow rate of sodium can be passed through this sponge in order to select the 500- to 550- $^{\circ}$ C ΔT we require. One of

the favorable characteristics of this module is its low operating pressure (~1.5 atm) and consequent low stresses. These low stresses, coupled with the low structural temperature, makes safety and integrity of containment the real attraction of this design concept.

The individual cauldron blanket modules are interspersed between successive solenoidal coils which are in turn spaced around four central meters at a distance determined by allowable ripple (5%) in the B field. There is likely to be 6 modules for each 4-meter section, or approximately 150 modules in all. The modules are isolated from the outside environment by:

- A double wall structure,
- A carbon reflector and shield,
- An interior envelope covering the reactor and held at approximately 10^{-6} to 10^{-5} Torr, and
- A 1.0- or 1.5-m steel-lined, concrete containment structure that is evacuated or contains an inert cover gas.

TRITIUM LOSS LEVELS

Tritium losses in the TMR were set below 10 Ci/d to meet the goal of emissions to the environment, while still maintaining worker safety and cost effectiveness. A number of new methods have been employed to achieve such low levels in a near-term machine. Figure 2 summarizes our goals for the various tritium leak source terms and the associated processing loops.

Tritium bred in the blanket will permeate the condenser tubes in the lithium-sodium pool boiler or the lithium-oxide helium contactor, and eventually the sodium loop feeding the numerous Incoloy-800 process exchangers within the large thermochemical plant. We have set a limit of this tritium leakage into the thermochemical process at 5 Ci/d. For 100,000 m³/h of hydrogen production, this would produce a maximum of 2 μ Ci/m³ of tritium (HT) in the hydrogen product, 20% of the 10- μ Ci/m³ limit established as a breathable atmosphere for the occupational worker. By the time any of this hydrogen gets to the market place, it would be diluted below the 0.04- μ Ci/m³ HT level set as a breathable atmosphere for the general public. For example, at a 10% level of hydrogen in natural gas supplies, a 0.04- μ Ci/m³ tritium (HTO) level would be typical. Brockman's group at Jülich (5) believe they can meet a 0.01- μ Ci/m³ level for HTO in the hydrogen used for synthetic natural gas. It appears uneconomical for us to meet such low levels in our design. Consequently, we have set a product level of 5 Ci/d for each of our design concepts able to meet this goal. Blanket module failure or sodium loop failures must not raise the tritium leakage into the thermochemical process to unacceptably high levels.

CONTROL OF TRITIUM PRODUCED IN THE LITHIUM-SODIUM POOL BOILER

In this section we outline several strategies for handling tritium in the lithium-sodium boiler blanket, and illustrate the key results. We examine first two alloy candidates, titanium-zirconium-

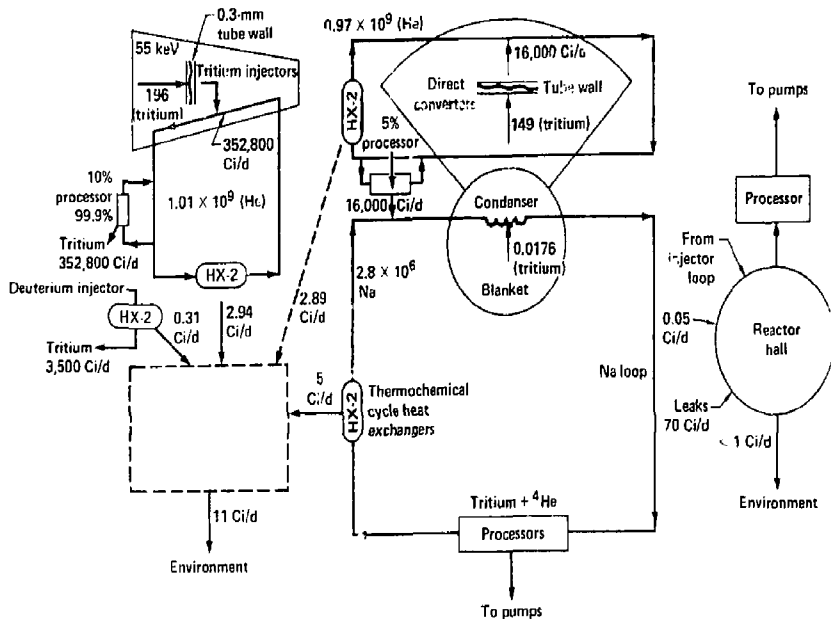

Figure 2. Tritium source terms and processing loops. All flow rates in g/h.

molybdenum alloy (TZM) and Incoloy-800, for the pool condensing-vapor heat exchanger. Then we look at the feasibility of niobium permeators and precious-metal moving getter beds.

First, we need to establish the relationship between the concentration (i.e., inventory) in the lithium-sodium boiler and the tritium partial pressure. There are no data that we know of concerning hydrogen or its isotopes in the lithium-sodium binary system. Heumann and Salmon (6), and Maroni and coworkers (7), have measured partial pressures of tritium, deuterium, and hydrogen over lithium from 700 to 1000°C. Tritium exhibits a very different partial pressure p dependence on concentration than do either deuterium or hydrogen, and there appear some doubts (7) as to whether Raoult's law ($p = X$) or Sievert's law ($p = X^2$) apply. Impurities in the tritium measurements may have caused these results to be anomalous, and recent data analyses (3) indicate Sievert's law is preferred. Consequently, we have used Sievert's law as representing the base case situation:

$$p(\text{atm}) = (X/K_s)^2,$$

where

$$K_s = 0.159 \text{ atm}^{-1/2} \text{ at } 950^\circ\text{C}, \text{ and}$$

$$X = \text{the mole fraction of tritium.}$$

If the lithium-sodium boiler has a 1256-m³ volume and contains 1 kg of tritium, we estimate the mole fraction of tritium (T) at about 10 ppw. This will differ slightly depending on the ratio of

lithium to sodium, but a mixture with equal amounts of each was used throughout. For this situation, the partial pressure of T is calculated as 4×10^{-3} atm, assuming the pu atomic species exists and neglecting H₂O, CH₃T, LiOT, NaOT, etc. These impurities are expected to be minor constituents, but should not be ignored completely.

Available permeator data (8-13) for various metals and alloys are displayed in Figure 3. It is obvious that for applications at about 950°C, alloys low on the plot are an excellent choice owing to their low tritium permeation.

Lithium-Sodium Vapor-Space Processing System With a TZM or Incoloy-800 Condenser

Here we outline the lithium-sodium vapor-space processing system, and then the main heat transfer loop and its tritium scavenging system (Figure 4). First we calculate the lithium-sodium vapor permeator area based on small-diameter niobium tubes 0.4-mm thick with 2-atm low-flow helium sweep gas flowing on the shell side at 1000°C. The tubes are hotter than the lithium-sodium vapor in order to keep the permeator surface clean. This permeator can be placed external to the blanket with the lithium-sodium vapor-space gases circulating through the tubes. If we assume 8% of the deuterium and tritium react (the upper limit), about 16 g/h of tritium will have to be recovered. With a permeation coefficient of 200 cc (STP)·cm/h·cm²·atm^{1/2} (8), a permeator area of 733 m² is required, assuming there is no

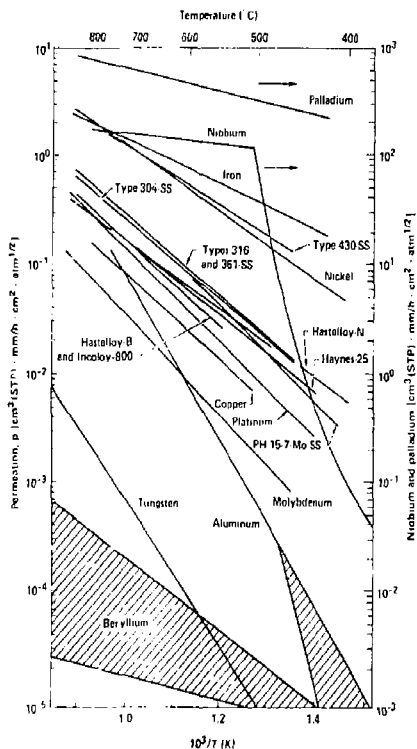

Figure 3. Permeation of hydrogen through various alloys.

degradation of surface activity from dirt and impurities.

With a partial pressure of 4×10^{-9} atm, the tritium (T_2) in the lithium-sodium boiler will permeate through the 6000 m² of T2M 1-mm-thick condenser walls at 600 Ci/h, assuming that the gas species is either OT or HT, and not T_2 . This permeation of tritium into the sodium loop will continue to raise the sodium-loop tritium concentration to a level that would adversely affect the thermochemical process. We believe that controlling the tritium loss to 5 Ci/d is mandatory. If we limit the permeation loss through the 6000-m² Incoloy-800 process exchanger to 5 Ci/d, the sodium-loop T_2 partial pressure must be held to 2×10^{-12} atm. This problem is made much easier by a chromium-oxide layer which is expected to form on the thermochemical process side as the result of oxidizing conditions in the stream. For this situation, a permeation coefficient of 3.5×10^{-3} is expected (13). The details of these results are discussed in Reference 14.

We can maintain the partial pressure in the sodium loop at 2×10^{-12} atm by means of a sodium loop permeator with an area of 120 m². The additional permeator would also be a niobium tube exchanger with hot helium sweep gas on the shell

side, and sodium on the tube side. Again, the tube would be kept at 1000°C, which is hotter than the sodium, in order to keep the surface clean. The hot helium would be scavenged of its low-level tritium by a conventional catalytic oxidation and mole sieve-adsorption process train (15-19).

The concentration of T_2 in the sodium loop corresponding to a partial pressure of 2×10^{-12} atm can be estimated from sodium-hydride data (20), assuming Sievert's law, at 2.6 ppb. These data and our methods of extrapolation are only approximate, but at least an estimate is helpful.

Incoloy-800 alloy for the in-blanket condenser is a viable alternate to T2M, as shown in Figure 5. This material permeates 3.5 times faster than T2M. Thus, the transport of tritium from the lithium-sodium boiler into the sodium loop will increase to 2090 Ci/h. If we still restrict process losses to 5 Ci/d, then we calculate from permeation rates that the sodium loop permeator area must be increased to 730 m². No other units in the process train need to be altered. We believe this larger permeator is still feasible.

Lithium-Sodium Vapor-Space Processing System With a Moving Getter Bed

This process is similar to the one above, except that the lithium-sodium boiler permeator is replaced by a getter bed (Figure 6). Here the getter bed must handle 16 g/h of tritium. From a mass balance computation, it appears feasible if the bed is continuously moved through a regenerator process circuit at a rate of about 38 kg/d for bed loadings of 1% by weight, or 380 kg/d for 0.1%. For a bed residence time of 10 h, this would amount to an inventory of only 160 g of tritium. With beds of 1-cm coated particles in lengths of several meters and diameters about a third of a meter, the pressure drops would be very small.

Although we have only experimental data on the performance of a yttrium getter bed with lithium at tritium ppm levels and 200°C (21), we believe we could process the inert-gas vapor-space at 950°C. Clearly, we need more experimental work. Singleton et al., (22) showed that good purification factors (i.e., inlet/outlet concentration ratios) of 10 to 20 were achievable with cerium in the tritium concentration range of 0.1 ppb to 100 ppb in argon. Because we are seeking levels of 10 ppm tritium in the lithium-sodium melt, these lithium-yttrium and helium-cerium performance tests are very encouraging. It appears that with adequate vessels (with tritium permeation lower than 316-stainless steel) the getter bed can be operated in excess of 600°C with no decline in performance (22).

Because yttrium-lithium-tritium getter systems can only reach about 1 ppm at 200°C, and we need levels of 2 to 10 ppb in the sodium loop, the yttrium getter approach does not appear workable.

Lithium-Sodium Vapor-Space Processing System With Tritium-Removal Heat Pipes

This process is also similar to those above, except that the lithium-sodium boiler permeator is replaced by tritium-concentrating heat pipes (Figure 7). The principle is discussed in References 23 and 24, and involves a conventional heat

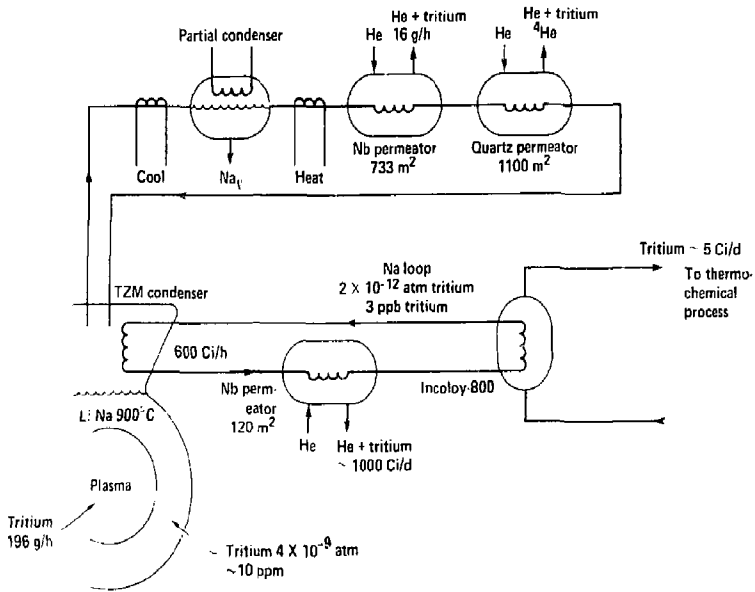

Figure 4. Lithium-sodium vapor-space processing system with a TZM condenser.

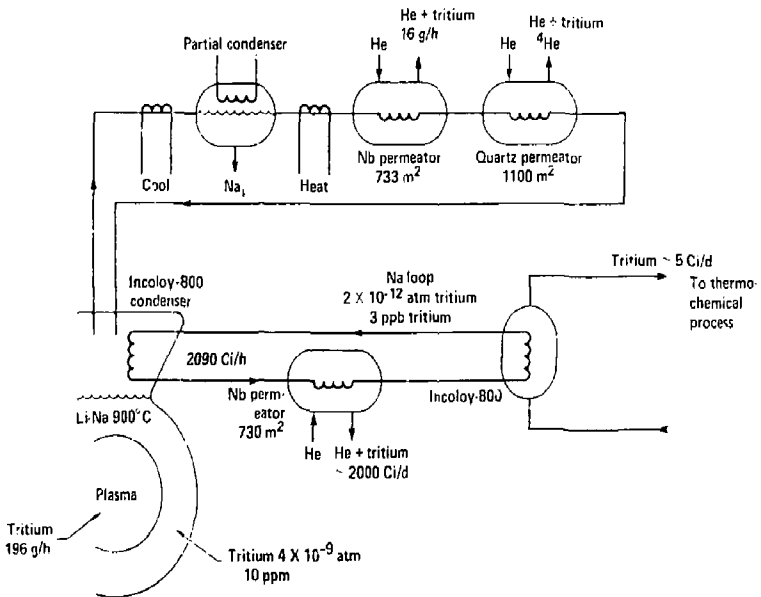

Figure 5. Lithium-sodium vapor-space processing system with an Incoloy-800 in-blanket condenser.

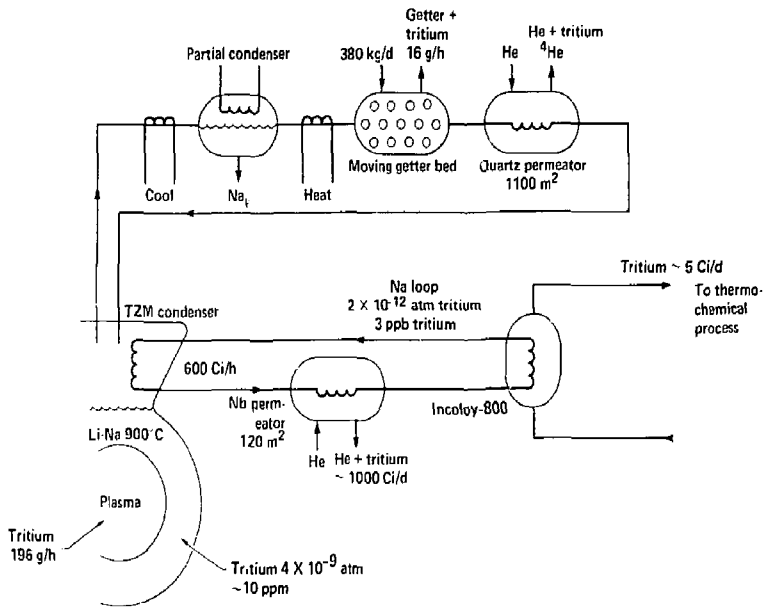

Figure 6. Lithium-sodium vapor-space processing system with a moving getter bed.

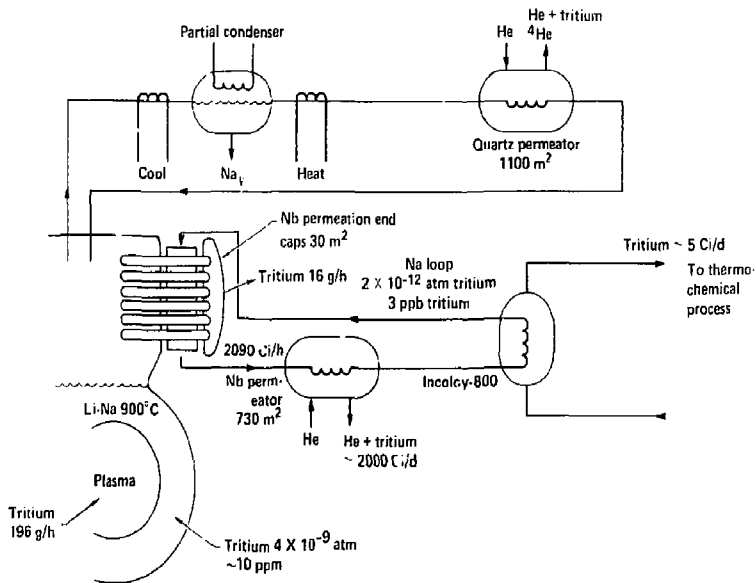

Figure 7. Lithium-sodium vapor-space processing system with tritium-removal heat pipes.

pipe that is gas-buffered where the inside sweep action of liquid-metal vapor pumps the gas and concentrates it at one end. If the gas contains tritium, this design allows T_2 concentration at partial pressures of approximately 1 atm in one end where permeation through a small window into the tritium purification process can proceed rapidly (24).

In the original concept, the heat pipe contained lithium, which under a neutron influence would breed tritium (24). In this case, however, we are breeding tritium in the lithium-sodium boiler, and would utilize this heat-pipe concept simply as a heat-driven concentrator using sodium. We first examined the feasibility of replacing the condenser tubes with heat pipes of Incoloy-800. The permeability of this alloy in a tube area of 6000 m^2 is, as previously indicated, 2090 Ci/h. The lithium-sodium boiler T_2 inventory is 1 kg at a partial pressure of 4×10^{-9} atm.

The condenser end would permeate tritium at the required rate to the tritium purification system through a small niobium window at the tube's end. This is possible because the T_2 in the heat pipe would increase to a partial pressure of about 5×10^{-3} atm.

Our design requires a heat transfer or permeation area of 1100 m^2 at the evaporator end of the heat pipe, as did the condenser shown in Figure 5. This design offers the advantage of concentrating and separating the tritium. Consequently, it appears that this tritium-concentrating heat pipe would be excellent for the blanket design where tritium breeding can be undertaken in the lithium-sodium pool, and removed by the heat pipe to a separate part of the process.

According to our calculations on back diffusion below, the heat pipe can operate with a large partial pressure difference between the ends (i.e., below 4×10^{-3} atm at the evaporator end, to about 4×10^{-9} atm at the condenser end) because the large driving force for back diffusion of tritium is against the sodium vapor velocity.

We can estimate the extent of this back diffusion by determining the binary diffusion (coefficient of tritium in sodium vapor). Critical properties for sodium vapor are as follows (25):

Temperature $T_c = 2860$ K
Pressure $P_c = 516$ atm
Volume $V_c = 150$ cc/mole
Density $\rho_c = 0.1533$ g/cc
Compressibility: $Z_c = 0.327$

We estimate the binary diffusion coefficient at 1200 K to be 2.23 cm^2/s , as discussed in Reference 26.

If we use 100,000 heat pipes about 2-m long and 2 cm in diameter, the sodium vapor flux will be about 4 gm/ $cm^2 \cdot s$, or a linear velocity of 116 m/s within the tube. We found that with the condenser end containing 2×10^{-2} atm of T_2 , the back diffusion of the T_2 is exactly matched by the bulk flow of the sodium vapor in the opposite direction to obtain an acceptable rate of 10 g/h of tritium. We can construct windows at the tube ends with a total area of 30 m^2 , determined from permeation calculations. These windows would be a 1-mm-thick disk of niobium, 2 cm in diameter,

fitted to the end of the tube. This permeation window design would contain the T_2 at the condenser end at a partial pressure of 1×10^{-3} atm, safely below the 2×10^{-2} atm at which back diffusion begins to be a problem.

REMOVAL OF HELIUM-4

The removal of helium-4 is critical to the operation of the blanket. The helium-4 is generated at a rate equal to that of the tritium, and the helium-4 will not permeate through metal permeators. We find that helium-4 will permeate through fused silica at about 10 times the rate of tritium in niobium, with a helium-4 partial pressure of 0.45 atm in the blanket (27-29).

As a result, helium-4 could be removed by a 1100- m^2 hot fused-silica window. Less than 0.1 Ci/h of tritium would pass through the window along with the 16 g/h of helium-4. The nearly pure helium-4 could then be fed to a standard catalytic oxidation/molecular sieve-adsorption unit to recover any residual tritium for the fuel purification process. The helium-4 would then be cleaned to tritium levels of about 0.1% that of the incoming stream, or less than 0.1 Ci/d. We believe at this point, the helium-4 could be safely stacked, adding less than 0.1 Ci/d to the estimated tritium loss of 10 Ci/d.

A partial condenser is required to remove vaporized lithium or sodium or other impurities that could condense on the fused-silica surface (or the niobium surface as well). By condensing out any impurities, and keeping these silica tubes hotter than the gas processor to avoid significant impurity adsorption, a long, high-efficiency life is ensured. This proposed technique would have to be tested, however, since even small amounts of non-condensed lithium or sodium would limit the lifetime of the fused-silica permeator. It would be advantageous to expand the function of this partial condenser with a processing loop capable of removing more complex impurities through the use of special getters or chemical scavengers.

Another major source of tritium leakage is the tritium neutral-beam injector, where 55-keV tritons implant tritium in the electrode tubing surface. Once in the tube metal, we calculate that the tritium will diffuse, producing a flow of tritium into the electrode helium-coolant flow at about 70,560 Ci/d. A 10% fraction of the coolant flow is then processed to remove 99% of the tritium. The resulting residual tritium leaks into the heat exchangers or steam generators at about 3 Ci/d, where it eventually passes into the cooling water and then to the environment. The neutronium injector uses deuterium with a maximum 1% tritium impurity level, and it creates a 0.3 Ci/d leak to the process.

A similar tritium loss occurs in the THR's direct converter, where 50-keV tritons produce a leak of 8000 Ci/d into the helium flow. Again, a 99.9% processor is used, handling 5% of the flow to reduce the tritium loss to less than 3 Ci/d.

All of the remaining miscellaneous leaks from the nuclear island equipment and piping or acting un-assumed to leak into the reactor hall at a maximum rate of 180 Ci/d. The reactor hall atmosphere is processed and kept at low humidity to maintain

tritium gas levels of below $40 \mu\text{Ci}/\text{m}^3$, and HTO levels below $10 \mu\text{Ci}/\text{m}^3$. As a result of this reactor hall processing design, routine as well as credible accidental losses of less than 1 Ci/d through the reactor hall are expected.

The tritium loss to the thermochemical process and thus to the environment is designed to be around 12 Ci/d, with 5 Ci/d dissipated from the blanket, 3 Ci/d from injectors, 3 Ci/d from the direct converter, and less than 1 Ci/d from the reactor hall. This level is consistent with other studies (15-18, 30-40) and Nuclear Regulatory Commission (NRC) regulations (41, 42) for all nuclear fuel cycle operations, but is about the level suggested by the NRC "As Low As Reasonably Achievable" (ALARA) cost-benefit analysis (19, 41-44) with an expenditure cutoff of \$66,000. Using the ALARA criterion, we found that no further reductions in emissions could be accomplished by an expenditure of \$56,000 for additional oxidizer-molecular sieves.

CONCLUSIONS

Ideally, the T_2 will be generated within the lithium-sodium mixture and the concentration will be allowed to increase to a 1-kg inventory or ~ 10 ppm on a molar basis or about $1000 \text{ Ci}/\text{m}^3$. The T_2 partial pressure will be maintained at a constant 4×10^{-3} atm by a scavenging system continually removing tritium from the vapor space above the lithium-sodium pool. For a tritium breeding ratio in slight excess of unity, this scavenging system must handle tritium at a rate of ~ 15 g/h or 150,000 Ci/h for a 2500-MW_t reactor. The key to the scavenging system is the use of a 0.4-mm niobium tubular-array permeator at a high temperature (1000°C). The surface area requirements were found to be 750 m². The interiors of these tubes are swept with 1000°C helium in order to keep the tubes hot, clean, and low in tritium. The tritium will be processed by conventional oxidation/adsorption processes. This technique maintains the tritium inventory in the blanket at ~ 1 kg. Helium-4, the other byproduct of the neutron-lithium reaction, is removed from the blanket vapor space by a fused-silica tube permeator of ~ 1000 m². A vapor condenser would protect the silica tube from liquid-metal condensation.

Tritium losses from the blanket through the heat exchangers into the thermochemical cycle must be controlled within acceptable limits ($2 \mu\text{Ci}/\text{m}^3$ or 5 Ci/d). In one of our conceptual designs, heat is extracted from this lithium-sodium pool boiler by sodium vapor condensation on Incoloy-800 tubes within the vapor dome of the blanket. Tritium will leak out of the blanket via this path into the liquid-sodium coolant flowing in these condenser tubes. The permeation rate was found to be 2000 Ci/h. Such a large permeation leakage can be controlled by installing another niobium tube permeator on the liquid-sodium flow side with a tube area of 730 m². Tritium would thus be removed at 2000 Ci/h. The partial pressure of tritium in the sodium loop will increase until the amount of tritium removed by the sodium-loop permeator, and the tritium leaked by permeation out of the Incoloy-800 process heat exchanger, exactly match the permeation into the sodium loop via the in-blanket condenser tubes. We find that when we do this trial

and error calculation, the T_2 partial pressure in the sodium levels at about 2×10^{-12} atm. We assume there is an oxide barrier in the Incoloy-800 process exchangers, such as sulfur trioxide decomposition. Actual high-temperature gas-cooled reactor experience at Peach Bottom has shown that Incoloy-800 offers excellent tritium retention properties by the formation of a protective oxide barrier with a permeation reduction factor of 200. With the oxide barrier, the tritium loss to the thermochemical process would be around 5 Ci/d, which meets our environmental goals. Further reductions of tritium losses were possible. However, they were not cost-effective according to the NRC criterion (ALARA) of \$1000/man-rem or \$20/Ci/y released.

We have explored several accident modes. The sodium loop between the fusion blanket and the process functioned effectively as an isolation loop. A 1% leakage of tritium at a breeding rate of 16 g/h would add only a 1600 Ci/h load to the sodium loop permeator, and increase tritium loss to the thermochemical process by only 28 Ci/d. This 1% leakage appears to meet the present day NRC criteria for fission plants. Likewise, gross failure of the in-blanket condenser would merely dump the lithium-sodium blanket material from one module (i.e., 1/150 of blanket inventory) into the sodium coolant loop. This would not result in explosive accidents, and add only 20 Ci/d to the tritium loss. All lithium-sodium vessels were surrounded with graphite spheres, and the sodium piping was contained within inerted pipeways that were steel-lined to prevent sodium concrete reactions.

The remaining tritium losses were calculated for permeation and leakage from other process component designs and found to be small (i.e., 3 Ci/d from the direct converter, 3 Ci/d from neutral-beam injectors, etc.). Tritium inventory within onsite, remote storage tanks was 16 kg. For the cryopumps, inventory was estimated to be 4 kg. Cryogenic distillation columns held 1.4 kg. The remaining cryopanel, molecular sieve beds, etc., contained a total of 0.5 kg. The in-process tritium inventory at risk therefore (not including storage tanks separated from the reactor), is expected to be about 7 kg.

REFERENCES

1. J.D. Lee, *Natural Lithium Liquid Blanket Concept for a DT Thermonuclear Reactor*, Lawrence Livermore Laboratory, Livermore, Calif., Thermonuclear Reactor Memo #2 (1968).
2. J.D. Lee, *vacuum Wall Cooling Scheme for Flowing Liquid Lithium Blankets*, Lawrence Livermore Laboratory, Livermore, Calif., Thermonuclear Reactor Memo #10 (1969).
3. J.D. Lee, *Some Thoughts on Heat Transfer in Liquid Lithium Blankets*, Lawrence Livermore Laboratory, Livermore, Calif., Thermonuclear Reactor Memo, #15 (1969).
4. J.L. Watts, "High Temperature Properties of Liquid Metals," *Space Power Notes* 227 (1967).
5. H. Brockman, "The Potential of Fusion Reactors in Providing Process Heat," *Brennst.-Wärme-Kraft* 31(2), 61-66 (1979).
6. F.K. Heumann and O.N. Salmon, *The Lithium, Hydride, Deuteride, and Tritide Systems*, Knolls

- Atomic Power Laboratory, New York, N.Y., KAPL-1667 (1956).
7. F. Velsokis, R.M. Yonco, and V.A. Maroni, *The Current Status of Fusion Reactor Blanket Thermodynamics*, Argonne National Laboratory, Argonne, Illinois, ANL-78-109 (1979).
 8. R.W. Webb, *Permeation of Hydrogen Through Metal*, Atomics International Div. North American Aviation, Inc., Cenoga Park, Calif., NAA-SR-10462 (1965).
 9. V.A. Maroni, *An Analysis of Tritium Distribution and Leakage Characteristics for Two Fusion Reactor Reference Designs*, Argonne National Laboratory, Argonne, Illinois, CEN/CTR/TM-9 (1974).
 10. V.A. Maroni, "Some Perspective on Tritium Permeation in Fusion Reactors Based on Existing Data and Experience," in *Proc. 1977 Annual Meeting of the ANS (American Nuclear Society, New York, 1977)*.
 11. J.T. Bell and J.D. Redman, *Tritium Permeation Through Metals Under Stean Conditions*, Oak Ridge National Laboratory, Oak Ridge, Tenn., in preparation (1975).
 12. R.A. Strehlow and H.C. Sausage, "The Permeation of Hydrogen Isotopes Through Structural Metals at Low Pressures and Through Metals with Oxide Film Barriers," *Nuc. Technol.* **22**, 127 (1974).
 13. L. Yang, W.A. Baugh, and N.L. Baldwin, *Study of Tritium Permeation Through Peach Bottom Steam Generator Tubes*, General Atomic Co., San Diego, Calif., in preparation (1977).
 14. R.W. Werner, O.H. Krikorian, and T.R. Galloway, *Thermochemical H₂ from a Tandem Mirror Reactor*, Lawrence Livermore Laboratory, Livermore, Calif., in preparation (1980).
 15. C.J. Kerschner and J.C. Pixel, "Tritium Effluent Control Laboratory," in *Proc. of the 13th AEC Air Cleaning Conference, San Francisco, August 12-15, 1974* (United States Atomic Energy Commission, Washington, 1975), vols. 1 and 31, pp. 948-971.
 16. J.L. Anderson et al., "Tritium Handling Facilities at the Los Alamos Scientific Laboratory," in *Proc. 23rd Conf. on Remote Systems Technology* (American Nuclear Society, New York, 1975).
 17. J. L. Anderson, Los Alamos Scientific Laboratory, Los Alamos, New Mexico, private communications (February 3, 1976 and September 21, 1977).
 18. T.R. Galloway, "Tritium Management in Fusion Reactors" in *Proc. Third ANS Topical Meeting on the Technology of Controlled Nuclear Fusion, May 9-11, 1978, Santa Fe, New Mexico* (American Nuclear Society, New York, 1978), pp. 910-923.
 19. A.E. Sherwood, *Tritium Removal from Air Streams by Catalytic Oxidation and Water Adsorption*, Lawrence Livermore Laboratory, Livermore, Calif., UCRL-78173 (1975).
 20. R.E. Elson, H.C. Hornig, W.L. Jolly, J.W. Kury, W.J. Ramsey, and A. Zolkin, *Some Physical Properties of the Hydrides*, Lawrence Radiation Laboratory, Livermore, Calif. UCRL-4519 (1955).
 21. R.E. Buxbaum and E.F. Johnson, *The Use of Yttrium for the Recovery of Tritium from Lithium at Low Concentrations*, Princeton Plasma Physics Laboratory, Princeton University, Princeton, N.J., PPPL-1548 (1979).
 22. M.F. Singleton, C.I. Folkers, and C.M. Griffith, "Assessment of Uranium and Cerium as Hydriding Materials for Hydrogen Isotopes in Flowing Argon," in *Proc. 1977 Annual Meeting of the ANS (American Nuclear Society, New York, 1977)*.
 23. J.D. Lee and R.W. Werner, *Concept for a Gas-Buffered Annular Heat Pipe Fuel Irradiation Capsule*, Lawrence Livermore Laboratory, Livermore, Calif., UCRL-50510 (1968).
 24. R.W. Werner, *The Generation and Recovery of Tritium in Thermonuclear Reactor Blankets*, Lawrence Livermore Laboratory, Livermore, Calif., UCID-15390 (1968).
 25. E. Morrlis, *An Application of the Theory of Corresponding States to the Prediction of Critical Constants of Metals*, Atomic Weapons Research Establishment, Aldermaston, Berkshire, England, AWRE-0-67/64 (1964).
 26. R.C. Reid and T.K. Sherwood, *The Properties of Gases and Liquids* (McGraw-Hill Book Co., New York, 1966), 2nd ed.
 27. J.E. Shelby, "Molecular Diffusion and Solubility of Hydrogen Isotopes in Vitreous Silica," *J. Appl. Phys.* **48**(8), 3387-3394 (1977).
 28. J.E. Shelby, "Helium Migration in Natural and Synthetic Vitreous Silica," *J. Am. Ceram. Soc.* **55**(2), 61-64 (1972).
 29. W.M. Jones, "Permeability and Solubility of ³He and ⁴He in Vitreous Silica," *J. Amer. Chem. Soc.* **75** 3093-96 (1953).
 30. L.D. Hansborough, "Tritium Inventories and Leakage: A Review and Some Additional Considerations," in *Symposium of CTR Technology, U.S.A.E.C., Series 31, (United States Atomic Energy Commission, Washington, 1974)*, pp. 92-104.
 31. D.J. Jacobs, *Sources of Tritium and Its Behavior Upon Release to the Environment* (United States Atomic Energy Commission, Washington, 1968).
 32. W.A. Swansiger and L.A. West, "Current Sandia Program and Laboratory Facilities for Tritium Research," in *Proc. of the Symposium of Tritium Technology Related to Fusion Reactor Systems, U.S. E.R.D.A. (United States Energy Research and Development Administration, Washington, 1976)*.
 33. R.W. Werner, Lawrence Livermore Laboratory, Livermore, Calif., private communication (1972).
 34. R.V. Osborne, "Adsorption of Tritiated Water Vapor by People," *Health Physics* **12**, 1527-1537 (1966).
 35. J.F. Draley and S. Greenberg, "Some Features of the Environmental Impact of a Fusion Reactor Power Plant," in *AEC Symposium on Tritium Technology, AEC No. 31 (United States Atomic Energy Commission, Washington, 1974)*.
 36. V.A. Maroni, "An Analysis of Tritium Distribution and Leakage Characteristics for Two Fusion Reactor Reference Designs," in *Proc. Fifth Symposium on Engineering Problems of Fusion Research* (Princeton University, New Jersey, 1974).

37. R.W. Moir et al., *Progress on the Conceptual Design of a Mirror Hybrid Fusion-Fission Reactor*, Lawrence Livermore Laboratory, Livermore, Calif., UCRLL-51797 (1975).
38. R.G. Clemmer, H.H. Land, W.A. Maroni, and J.M. Mintz, "Simulation of Large Scale Air Detritiation Operations by Computer Modeling and Bench-Scale Experimentation," in *7th Symposium on Engineering Problems of Fusion Research, Knoxville, Tennessee, 1977* (American Nuclear Society, New York, 1977).
39. T.E. McKone, *Environmental Effects of Normal and Off-Normal Releases of Tritium from CTR Systems*, University of California, Los Angeles, California, for the Electric Power Research Institute, EPRI ER-879 (1978).
40. S.J. Piet and M.S. Kazimi, *Uncertainties in Modeling of Consequences of Tritium Release from Fusion Reactors*, Massachusetts Institute of Technology Plasma Fusion Center, Cambridge, Mass., PFC/TR-79-5 (1979).
41. *U.S. Federal Register* 40(104), 23420 (1975).
42. *U.S. Federal Register* 40(158), 40816 (1975).
43. A.E. Sherwood, Lawrence Livermore Laboratory, Livermore, Calif., private communication (October 19, 1976).
44. International Commission on Radiological Protection, *Report on Permissible Dose for Internal Production, Recommendations of Committee 2* (Pergamon Press, Inc., New York, 1959), p. 233.

NOTICE

"This report was prepared as an account of work sponsored by the United States Government. Neither the United States nor the United States Department of Energy, nor any of their employees, nor any of their contractors, subcontractors, or their employees, makes any warranty, express or implied, or assumes any legal liability or responsibility for the accuracy, completeness or usefulness of any information, apparatus, product or process disclosed, or represents that its use would not infringe privately-owned rights."

JAS