

CONF-850504--92

Los Alamos National Laboratory is operated by the University of California for the United States Department of Energy under contract W-7405-ENG-36

LA-UR--85-1656

DE85 012704

TITLE: CAVITY-COUPLING INVESTIGATION FOR THE PHERMEX  
50 MHz RF ACCELERATOR

AUTHOR(S): E. W. Pogue and F. R. Buskirk

SUBMITTED TO: IEEE, 1985 Particle Accelerator Conference,  
Vancouver, B.C., Canada, May 13-16, 1985

DISCLAIMER

This report was prepared as an account of work sponsored by an agency of the United States Government. Neither the United States Government nor any agency thereof, nor any of their employees, makes any warranty, express or implied, or assumes any legal liability or responsibility for the accuracy, completeness, or usefulness of any information, apparatus, product, or process disclosed, or represents that its use would not infringe privately owned rights. Reference herein to any specific commercial product, process, or service by trade name trademark, manufacturer, or otherwise does not necessarily constitute or imply its endorsement, recommendation, or favoring by the United States Government or any agency thereof. The views and opinions of authors expressed herein do not necessarily state or reflect those of the United States Government or any agency thereof.



By acceptance of this article, the publisher recognizes that the U.S. Government retains a nonexclusive, royalty-free license to publish or reproduce the published form of this contribution, or to allow others to do so, for U.S. Government purposes.

The Los Alamos National Laboratory requests that the publisher identify this article as work performed under the auspices of the U.S. Department of Energy

NOTED

Los Alamos Los Alamos National Laboratory  
Los Alamos, New Mexico 87545

2

# CAVITY-COUPLING INVESTIGATION FOR THE PHERMEX 50 MHz RF ACCELERATOR

E. W. Pogue and F. R. Buskirk\*  
Los Alamos National Laboratory  
P.O. Box 1663  
Los Alamos, NM 87545

## Abstract

The PHERMEX accelerator is a three-cavity rf linac that operates at 50 MHz. Each cavity has a radius of 2.3 m and a length of 2.6 m. The accelerator produces an electron beam with a peak current of 500 A and energy of 30 MeV.[1,2] RF power is supplied by multiple 2.5-MW tetrodes feeding coaxial lines with loops in the cavity wall. To increase the fields, multiple tetrodes and coupling loops must be used in each cavity; the problems associated with multiple-loop coupling are investigated.

## Introduction

The PHERMEX accelerator is unique in that it uses large (4.6 m diameter) resonant cavities to provide the accelerating gradients for the electron beam. The cavities are driven in the  $TM_{010}$  standing wave mode at 50 MHz by 5 Mwatt rf amplifiers. The electric field is along the axis, depends on  $r$  only, is a maximum on the axis, and is zero on the cylindrical boundary. The magnetic field is in the  $\theta$  direction and loops in the cylindrical wall couple by the B field to excite the cavity. The resulting E field on the axis accelerates the beam. A high Q of more than  $10^5$  may be realized from large cavities with a small surface to volume ratio. This high Q results in a high stored energy and thus large accelerating field. These may be increased further by multiple power feeds into a single cavity and investigation of the power feed, in particular the coupling loops in the cavity, from the subject investigated here.

PHERMEX has three cavities of 2.3 m radius and 2.6 m length, a Q of  $1.30 \times 10^5$ . Total energies of near 30 MeV are possible with two amplifiers per cavity. Power is fed from 14-in. coaxial lines. Six ports separated by about 0.7 m are arranged three on each side; now only two are used for power feed. Figure 1 shows a schematic of the accelerator, and Figure 2 shows the measured output current.

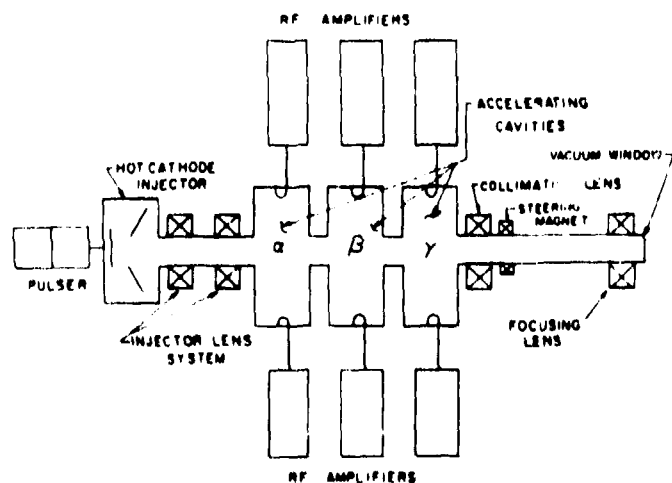

Fig. 1. PHERMEX accelerator schematic.

\*Work performed under the auspices of the U.S. Department of Energy.

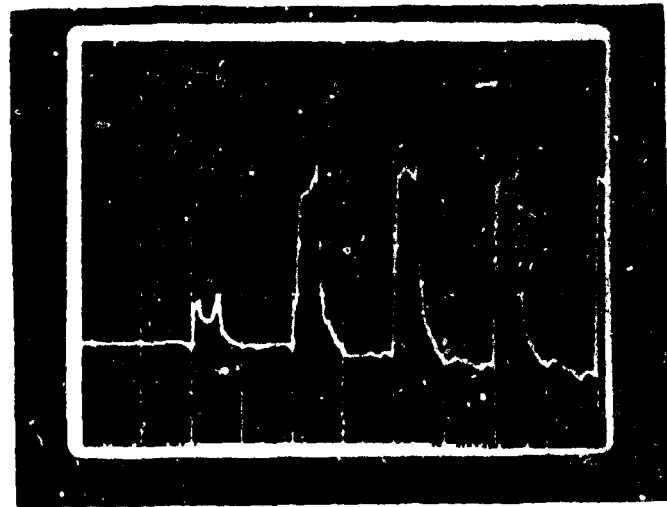

Fig. 2. Output beam current measured by B monitor; four of nine bunches are shown.

## Investigations

To investigate coupling into the PHERMEX cavities, an earlier test cavity was fed with c.w. low power (2 watt) using one, two, or three loops. Cavity fields and reflected power from each loop were monitored, the frequency and coupling were varied. The latter could be accomplished either by rotating the plane of the loop relative to the cavity field or by changing the area.

To understand the situation, the equivalent circuit is shown in Fig. 3. The power tubes are assumed to be constant V, each loop has self-inductance  $L_0$  and is coupled to the equivalent L of the cavity by a mutual inductance M. R represents the cavity wall losses and C the capacitance such that LC determine the resonant frequency if the M's are zero.

The circuit equations yield an impedance  $Z_1$  which is seen by each feed line at the loop:

$$Z_1 = j\omega L_0 + \frac{nM^2\omega Q}{L} \frac{1-j2\alpha}{1+\alpha^2} f_1 \quad (1)$$

$$f_1 = 3M_1 I_1 / \sum I_k M_k \quad (2)$$

$$I_1 = \text{Current flowing through each loop}$$

$$n = \text{number of coupling loops per cavity} \quad (3)$$

$$\alpha = \frac{\omega - \omega_0}{\omega_0} Q \quad (4)$$

$$\omega_0 = (LC)^{-1/2} \quad (5)$$

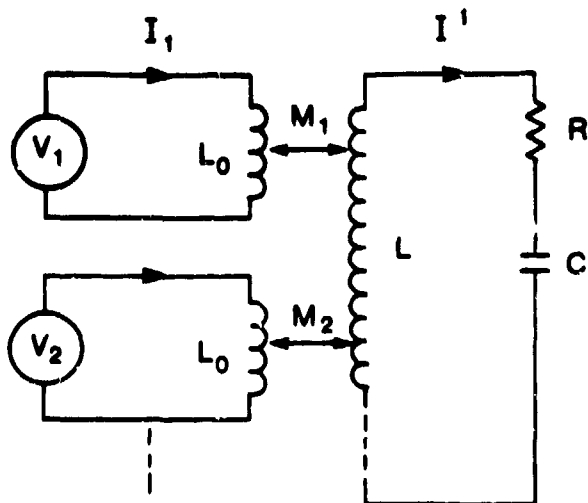

Fig. 3. Equivalent circuit for multiple loops feeding power into a single cavity.

Eq. 1 gives the impedance that must be matched to the 60 ohm line and tube to avoid reflection. As  $n$  increases,  $M$  must decrease. For identical drive lines and currents, each  $f_i$  is unity; if any line is different from the other, all  $f_i$  change and affect the impedance. In Eq. 1, no direct coupling between adjacent loops is assumed; all interaction between loops is assumed to occur through excitation of the cavity mode which then couples to a second loop by induction. Eq. 1 also reveals the basic operating approach. The second term has a real and imaginary part. The latter is changed by detuning ( $\alpha \neq 0$ ) until the sizable  $j\omega L_0$  term is canceled. Then the real part of  $Z_i$  must match the transmission line impedance to avoid reflection; this matching is accomplished by varying  $M$ . As  $n$  increases,  $M$  must be smaller, either by varying the loop area or by rotation such that less cavity flux couples through the loop. The latter method does not change  $L_0$ .

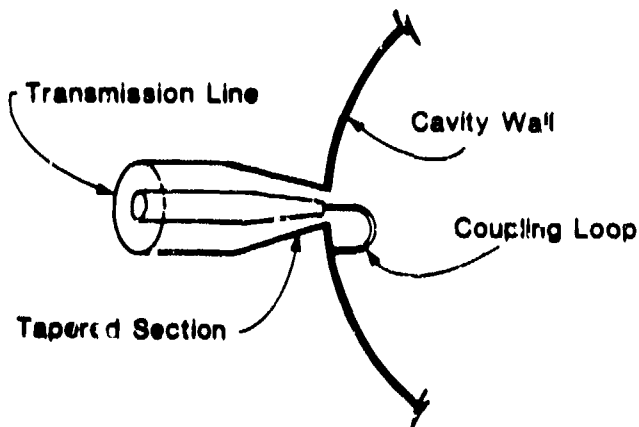

Fig. 4. Transmission line, loop, and cavity.

Figure 4 is a drawing of a loop in a cavity. The transmission line is 60  $\Omega$ , 14-in. diameter coaxial line that maintains its 60  $\Omega$  through the taper to the loop. The angle of loop rotation ( $\theta$ ) is measured from the fully coupled horizontal position.

### Results

One, two, and three loops were tested; sets of loops of three different areas were used.

The coupling loops used were 0.5-in. Cu rod in a "U" shape, with a 2.2-in. radius of curvature and total height of 5 in., 3 in., and 2.3 in., designed for 1, 2, and 3 loop coupling into the cavity, respectively. The results are as follows.

1. For 3-in. loops, matching was obtained by varying the frequency and  $\theta$ , for 2 and 3 loops.  $M$  was found to be proportional to  $\cos\theta$ , as usually quoted, in contrast to a few references stating that  $M^2$  should be proportional to  $\cos\theta$ .
2. Comparing different size loops, the effective area in  $M = kA_0 \cos\theta$  is given by  $A_e = A + A_c$  where  $A_c = 4.0 \text{ in.}^2$  and  $A$  is the actual loop area.  $A_c$  is introduced to represent the area in the throat of the transmission line taper that also couples into the cavity.
3. Two and three loops were mounted in various of the 6 possible cavity ports. No difference was found. We conclude that all positions couple equally to the  $TM_{010}$  mode and that no direct coupling between the loops exists; all coupling occurs via excitation of the cavity.
4. For multiple drives, unequal currents in the drive lines cause reflections in all drive lines; see Eq. 1 with  $f_i \neq 1$ .
5. In result 4, it was noted that if the cavity is driven by 3 matched lines, all tuned to give no reflections, that a change in current in one line will cause reflections in all three. A computer code was written to check if the resulting reflections would cause current changes and lead to a divergent or convergent disturbance. The convergent result was found.

### References

- [1] D. O. Venable et al., "PHERMEX: A Pulsed High Energy Radiographic Machine Emitting X-rays." Los Alamos Report LA-3241 (1967).
- [2] T. P. Starke, "PHERMEX Standing-Wave Linear Electron Accelerator," IEEE Trans. Nucl. Sci. NS 36 1402 (1983).
- [3] R. Beringer in "Principles of Microwave Circuits," Ed. by C. G. Montgomery, MIT Radiation Lab. Series Vol. 8, McGraw Hill (1948).