

30
6-12-86 v2A

①

cat. #

77-1070-7

I-21361

SLAC-PUB--3621

DE85 013067

CONF-850504--111

RF BEAM DEFLECTION MEASUREMENTS AND CORRECTIONS IN THE SLC LINAC*

JOHN T. SEEMAN, MARC C. ROSS,
JOHN C. SHEPPARD AND RAE F. STIENING

Stanford Linear Accelerator Center
Stanford University, Stanford, California, 94305

ABSTRACT

The requirements of RF acceleration in the SLC Linac to produce high energy beams are complicated by the presence of small transverse RF beam deflections which arise from several sources. These RF deflections place stringent tolerances on the phase and amplitude stability of the klystrons. They also force the use of special magnetic bumps to correct the trajectories of oppositely charged beams that will pass down the linac. If left unabated, RF deflections can limit the performance of the SLC. There are several methods to reduce the deflections. Many measurements of RF deflections have been made in the low energy part of the linac where the beams are most sensitive.

TOLERANCES ON RF BEAM DEFLECTIONS

The SLC linac must accelerate both electrons and positrons. Both beams are injected from their respective damping rings at 1.21 GeV and ultimately reach 50 GeV. The transverse emittances of these beams are quite small and must be maintained. Trajectory errors in the linac will cause the beams to exhibit betatron oscillations in the FODO lattice of the linac, excite transverse wakefields, and enlarge their emittances. Static trajectory errors can be corrected by DC dipole magnets. However, studies^{1,2} have shown that pulse-to-pulse fluctuations in the launching conditions or steering early in the linac must be kept below 13 μm or 0.3 μrad ($\beta = 42 \text{ m}$). These jitter tolerances relax as the beam energy increases.

Small radial asymmetries in the RF fields in an accelerator will deflect beams transversely. The effects of these fields can be observed as beam trajectory errors downstream of an accelerator section driven by a klystron. An example is shown in Fig. 1. In the SLC, both electrons and positrons are deflected in the same direction. Special static magnetic bumps are used to compensate for these deflections. Fluctuations in the RF power or phase will cause trajectory errors which cannot be corrected. Using the tolerances stated above and the fact that klystron phase and amplitude jitters can be kept below 0.5 degrees and 1%, respectively, RF deflections must be kept below 50 keV/c per klystron immediately downstream of the damping rings³, i.e., the RF fields must be aligned to one part in five thousand.

STATIC TRAJECTORY CORRECTION

Identical RF deflections given to both electrons and positrons can not be corrected by a single dipole magnet which steers the beams in opposite directions. However, several dipole magnets with interspersed quadrupoles can form a "magic" dipole bump which can be used to correct the deflections. Several magic bumps have been invented^{4,5}. An example is shown in Fig. 2. The bump capitalizes on the out-of-phase beta functions of the two oppositely charged beams in the linac FODO lattice. The three dipole correctors form a closed beam bump.

*Work supported by the Department of Energy, contract DE-AC03-76SF00515

The kicks of the two beams in the central quadrupole exactly cancel those of the lumped RF deflections located there if the bump sign and amplitude are properly chosen.

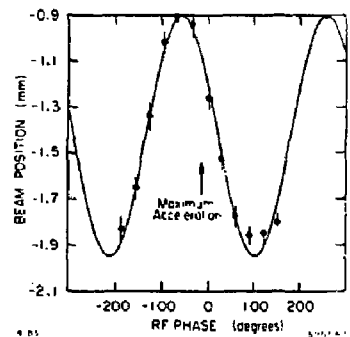

Fig. 1. RF deflections of a beam in an accelerator are observed as beam position changes downstream.

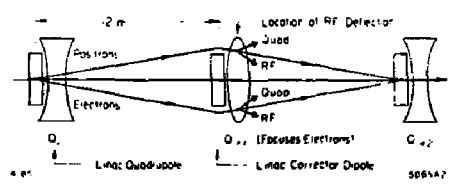

Fig. 2. A "magic" dipole bump corrects for static RF deflections given to electrons and positrons.

SOURCES OF RF DEFLECTIONS

RF Couplers

The power from a klystron is divided to feed equally four ten foot accelerator sections which are mounted on a forty foot girder. The single sided horizontal input and output couplers produce asymmetries in the RF fields in the first and last cells in the each section. A coupler and accelerator cavities are illustrated in Fig. 3. The deflections have been minimized in the SLAC accelerator by displacing the first and last cell radially and by orienting the eight couplers on a girder so as not to produce a net deflection or offset. Nevertheless, effects of the couplers have been observed⁶. A calculation⁷ for SLC SLED II 50 MW conditions gives 20 keV/c deflections per coupler.

Tilted Irises

External mechanical measurements of several accelerator sections have revealed that the irises of the cavities can be

Poster paper presented at the 1985 Particle Accelerator Conference
Vancouver, B.C., Canada, May 13-16, 1985

DISTRIBUTION OF THIS DOCUMENT IS UNLIMITED
26

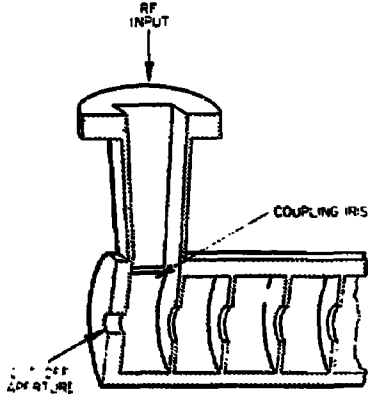

Fig. 3. SLAC disk-loaded accelerator showing a cross section of the cavities and end coupler.

tilted as shown in Fig. 4. These tilts cause RF deflections. The tilted irises originated during manufacture from the tilts of the end coupler assemblies upon which the remainder of the accelerator was stacked before brazing, accumulations of small machining errors, or small captured dirt particles.

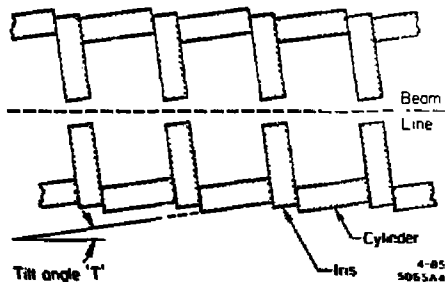

Fig. 4. Observed tilting (exaggerated) of the irises and cylinders of the SLAC disk-loaded waveguide.

Simple calculations of deflections can be made by assuming the RF fields rotate with the same angle as the irises. The expected transverse deflection δp is given by

$$\delta p = \frac{1}{c} \sum_{i=1}^n T_i \delta E_i$$

where c is the speed of light, n is the number of cells, and T_i and δE_i are the tilt angle and energy gain, respectively, for cell i . The SLC tolerances require that the average tilt angle for an accelerator girder be below 0.21 mrad early in the linac. The tilt angles for several ten foot sections have been measured⁹ and the spectrum is shown in Fig. 5. Several of the accelerator sections exceed the specifications and must be exchanged.

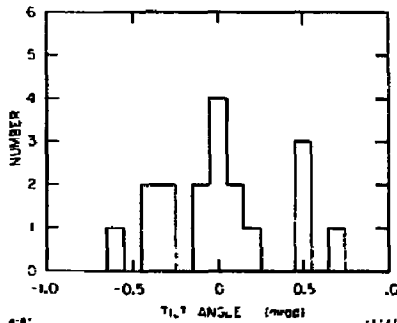

Fig. 5. Spectrum of measured tilt angles of several SLAC ten-foot accelerator sections.

Misalignments

Mechanical misalignments can cause RF deflections. A laser monitoring system is used to align the ends of the girders to better than 100 μ m over the length of the 3 km linac. Within a girder a local survey is used. Figure 6 shows the survey data of a girder with several problems: the welded joint between two accelerator sections has an offset, one section has an internal bulge, and the intragirder supports are misaligned. All of these effects have been removed from the first 300 m of the linac to a level of $\pm 100 \mu$ m or about ± 10 KeV/c.

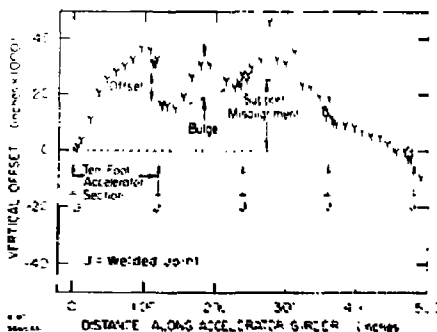

Fig. 6. Vertical survey of a girder, showing offsets, bulges, and intragirder support misalignments before corrections.

Trajectory Errors

A beam which has a trajectory error in a girder will be given a transverse deflection arising from the combined effects of the fringe-field lens at the ends of the girder and the effectively misaligned fields within the girder. The transverse deflection⁹ is given by $\delta p = E_0(x_2 - x_1)/2L$ where E_0 is the energy gain in the length L and x_1 and x_2 are the entrance and exit beam offsets, respectively, from the axis.

DEFLECTION MEASUREMENTS

Measurements of RF deflections in the linac were made using the apparatus shown in Fig. 7. Without RF power the beam was steered to the center line of the girder under test.

When the RF was applied the beam trajectory deviated (in general) from its nominal positions in two position monitors immediately downstream. From knowledge of the outgoing trajectory two effective RF kicks located at the one quarter and three quarters points inside the girder could be determined. Measurements were made as a function of RF phase allowing separation of the in-phase and out-of-phase components of the deflections. An example of a measurement is shown in Fig. 1. The beam energy in these tests was about 1 GeV. There were no magnetic fields in the region.

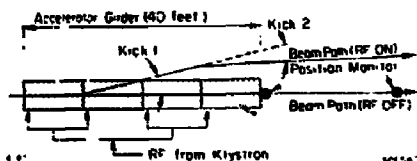

Fig. 7. Measurements of RF deflections were made by changing the phase of the RF power from a klystron which drives a forty-foot girder and observing the beam trajectory.

The first sixteen accelerator girders downstream of the damping rings were measured. The calculated in-phase deflections (Kick₁ and Kick₂) for eight girders are listed in Table 1. The out-of-phase components are similar. Several of the girders exceed the SLC specifications. A remedy for poor girders is to exchange them with good girders from the high energy part of the linac where the tolerances are greatly relaxed. The original Girder 2-4 was exchanged with a measured good one 700 m downstream. After the exchange, the RF deflections were remeasured and found to have moved with the accelerator sections as can be seen in the data of Table 1.

Table 1. Measured in-phase transverse RF deflections for SLED II 50 MW conditions.

Girder	Horz		Vert	
	Kick 1 keV/c	Kick 2 keV/c	Kick 1 keV/c	Kick 2 keV/c
22	-6.3	1.9	-13.4	3.8
23	-28.0	-11.7	-14.7	-5.6
24*	35.5	2.1	49.2	9.8
24**	0.3	9.0	-13.6	3.5
25	9.3	-11.2	-9.9	-0.5
26	-13.9	-0.1	30.2	1.5
27	-18.4	25.1	-5.2	-39.6
28	-19.1	61.4	84.3	-118.8

* Original girder.

** New replacement girder.

The RF kicks from beam trajectory errors in a girder have been studied on one girder. The measured kicks as a function of trajectory angle are plotted in Fig. 8. Additional measurements show that beam offset data look nearly the same. Clearly, beam trajectory errors (or girder misalignments) can cause sizable RF steering.

The effects of tilted irises have also been observed. The original Girder 2-4 had measured tilted irises³. Predictions of

the vertical deflections due to the couplers, mechanical misalignments, and tilted irises for that girder are shown in Table 2. The measured kicks are also shown. The measurements and predictions indicate that there is a strong correlation between tilted irises and RF deflections.

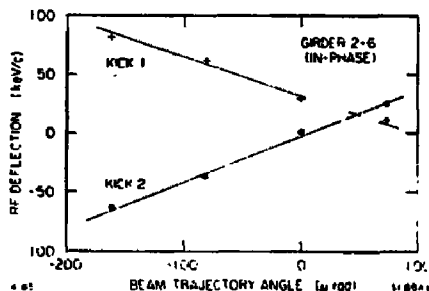

Fig. 8. Measured RF deflections versus beam trajectory angle through a girder extrapolated to SLED II 50 MW conditions.

Table 2. Predicted and measured vertical RF deflections for Girder 2-4 without SLED at 28 MW.

Predictions/ Measurements	Kick 1	Kick 2
Coupler Asymmetry	0.0 keV/c	0.0 keV/c
Survey Errors	0.2 keV/c	-0.2 keV/c
Tilted Irises	17.2 keV/c	-6.0 keV/c
Total Predicted	17.4 keV/c	-6.2 keV/c
Measured Deflection	29.2 keV/c	-3.7 keV/c

ACKNOWLEDGEMENTS

We thank J. Jasberg, G. Loew, R. Miller and W. Panofsky for discussions of RF deflections and the SLAC Mechanical Engineering, Alignment, and Operation Departments for aiding in the measurements.

REFERENCES

1. A. Chao, et. al., 11th Int. Conf. on High-Energy accelerators, Geneva, 597, (1980).
2. SLC Design Handbook, SLAC, December 1984.
3. R. Stiening, SLAC CN-181, (1982).
4. J. Seeman, SLAC CN-251, (1983).
5. R. Stiening, SLAC CN-12, (1980).
6. R. Miller, SLAC 50, 74, (1965).
7. G. Loew and R. Neal, *Linear Accelerators*, P. Lapostolle and A. Septier, Eds. North-Holland Pub., 96, (1970).
8. J. Seeman, SLAC CN-292, (1985).
9. R. Helm, *The Stanford Two-Mile Accelerator*, R. Neal, Ed., W. A. Benjamin, Inc., 192, (1968).