

Wire Scanners for Beam Size and Emittance Measurements at the SLC*

M.C. Ross, J.T. Seeman, E. Bong, L. Hendrickson, D. McCormick, L. Sanchez-Chopitea
Stanford Linear Accelerator Center,
Stanford University, Stanford, Ca. 94309

ABSTRACT

The SLC wire scanner beam profile monitors provide accurate beam size and emittance measurements for each bunch in the three bunch SLC beam. The beam size measurement error for typical 50GeV SLC linac beams ($100\mu\text{m } \sigma_{(x,y)}$) is better than $5\mu\text{m}$. Beam profile measurements can be performed throughout much of the SLC with no interruption to normal machine operation and no adverse impact on interaction region detector backgrounds. The linac input and output emittance is determined using sets of four scanners spaced by $\sim 45'$ betatron phase advance. Each scanner contains three wires, x, y and u (45°), from which an estimate of the x - y coupling can be obtained. Advanced high level control software allows the use of wire scanner data in feedback and beam optimization procedures. Non-invasive scans are performed almost continually and the results are logged so that long term trends in emittance can be examined. In this paper we describe the design, construction, performance and uses of SLC wire scanners.

INTRODUCTION

Measurements of the beam size and associated optical parameters are key to SLC. In the past progress has been slowed by our inability to measure beam size accurately in a rapid, non-invasive manner.

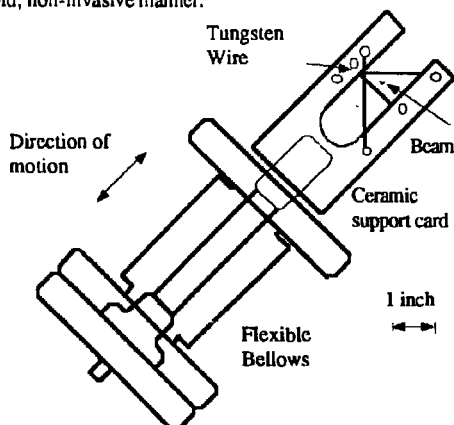

Figure 1: SLC wire scanner wire support card viewed in the beam direction. The translation stage and vacuum chamber are not shown.

*work supported by Department of Energy contract DE-AC03-76SF00515

In this paper we describe the design, construction, commissioning and ultimate uses of wire scanners in the SLC focusing on the linac and upstream systems scanners. Of particular interest is the interaction between the wire and the scattered radiation from the wire with the extreme electric field of the beam. As this field reaches the level of several volts/angstrom, as it does easily at the SLC interaction point (and may in upstream parts of SLC), field emission from the wire may occur.

A key feature of SLC operation is the degree of high level active control required to keep it optimized. The high level of demand takes the instrument out of the category of a device primarily used for machine development or failure diagnosis purposes and elevates it to an online device.

Feedback requires a fast, non-invasive (or minimal impact) device which in turn means that the wire, not the beam, must be moved during the scan. The speed, range, vibration and other mechanical specifications can be generated from this requirement and from the expected beam sizes and rates. Table 1 shows the expected performance of the scanners.

MECHANICAL

The mechanical design effort addressed the following problems: 1) wire and wire retention, 2) vibration over the large speed range and 3) positioning errors and position transducers. A particular concern was radiation damage.

A schematic diagram of the scanner is shown in figure 1. Several labs have built scanners of a similar design^{1,2}. The wire is strung around 1.5mm stainless steel studs set in a 3/16in thick alumina fork in such a way so that it can carry wires of three different orientations across the beam and provide x, y and u (45°) scans. The carriage motion is actuated by a stepping motor through a 2mm pitch ball screw, chosen because of the expected large number of cycles. Some difficulty was experienced obtaining the small pitch, high quality ball screw with no plastic parts. A 125 μm thick stainless steel vacuum window opposite the wire allows low energy wide angle scattered radiation to emerge from the vacuum chamber.

Both the cantilever nature of the wire support and the stepping motor contribute to wire vibration. We have used a piezo-electric accelerometer to quantify the motor related system vibration.

The wire chosen for the scanner was gold plated tungsten with a diameter of $0.3 \sigma_{\text{beam}}$. The wire has an effective σ of radius/2 which, when added in quadrature to the beam size, causes a 3% apparent increase when $\sigma_{\text{beam}} = \text{wire diameter}$. Under normal conditions the wire size can be subtracted in quadrature from the measured size.

MASTER

EB

At full SLC currents and rates, the beam can heat the wire substantially reaching a steady state temperature of 1000°C. In the fast scan mode, the wire is subjected to continuous beam for no more than a few seconds. However, the wire may be parked in the beam in error or for diagnostic purposes and must be able to withstand continuous beam. By measuring the increase in resistance of the wire assembly an estimate of the wire temperature rise can be made. Resistance tests show good agreement with a calculated rise of about 4° C/pulse.

Table 1: Wire scanner performance specifications.

Beam size resolution	<3% σ ($\approx 3 - 10 \mu\text{m}$)
Systematic error	<3% σ ($\approx 3 - 10 \mu\text{m}$)
Emittance (ϵ) error	10% (for $\gamma\epsilon = 3 \times 10^{-5}$ m-rad)
Dynamic range	$10^9 - 10^{11}$ particles/pulse
Vibration	Peak amplitude < 0.2 σ
Relative positioning	20 μm
Speed and acceleration	1cm/s max 0.3mm/s min; 0.2m/s ² accel.
Multibunch operation	<5% signal contamination from nearby bunch (60ns)
Radiation resistant	10Mrad/year
Lifetime	100,000 cycles/year

As the wire is scanned through the beam its position is not encoded on each successive beam pulse, rather the current position of the wire is inferred from a check of the remaining step count. A position measurement using a radiation hard LVDT (linear differential transformer) is done at the limits of the scan to check that the expected position was reached.

CONTROLS

A scan consists of three steps: 1) move from PARK (near, but not in, any of the beams) to the start of scan at maximum speed, 2) scan at the speed corresponding to the desired inter-point spacing and beam rate and 3) return to PARK at full speed. Only brief pauses, to allow the device to come to a complete stop, occur during the scan sequence. During multiwire emittance or skew scans, the wire moves to the next appropriate PARK. An important feature of this scheme is the use of machine wide data acquisition codes which coordinate the readback of the scanner step count and the signals from the wire scanner detector and therefore allow a great deal of flexibility in the choice of detector including, for example, the use of detectors several miles away.

Because the scanners are to be used for feedback, the application software that controls them must have sophisticated exception handling, error logging and status reporting. The control system software built around these devices allows use of the wire scanner at several levels. The lowest is the single scan and associated single pulse detector signal readout. This information allows checking the fit quality, scan ranges and other details. At the next level higher, the fit results can be used in the SLC control system correlation plot utility.⁴ This extremely powerful tool,

allowing the acquisition of scan data with other beam diagnostic data and machine parameters, has been invaluable for commissioning the scanners. All aspects of the gaussian fit to the scan data are available and are automatically acquired as an upstream device setting is controlled in a programmed way. Most automated optimization procedures are built around this facility. The next level of software does multiple scans and accumulates these results in the correlation plot utility. This includes four wire emittance scan results and skew scan results. Finally, feedback can perform the scans as a background task and implement the desired corrections.

SIGNAL DETECTOR

The purpose of the wire signal detector is to indicate the amount of charge striking the wire. Secondary emission and forward scattering, used in many wire scanner systems, are often not practical at the SLC, the first because of problems discussed below and the second because of the very different beam line areas in which these devices have to operate. The most difficult region is just upstream of a high power collimator system. Radiation scattered by the wire in the forward direction is completely overwhelmed by the scattering from the collimator jaws thus making the use of small angle scattered radiation impossible.

When the SLC interaction point (IP) wire scanners⁵ were first tested it was found that the secondary emission signal would increase dramatically when either the beam intensity exceeded about 5×10^9 or the $\sigma_{\text{beam}} < 10\mu\text{m}$. The onset of this dramatic increase is indicated by a very unstable signal. In the SLC linac, where the beam sizes are about 100 μm , a beam intensity of about 2.5×10^{10} is required. This effect appears to be field emission induced by the field of the beam which peaks at about 20V/Å.

Because of these problems, tests were made to determine if a significant signal was present at 90° to the beam direction, directly opposite the wire support card. A strong, very low energy electron signal was seen in a bare photomultiplier (PMT) placed about 30cm from the wire. A thin window is required so that this scattered radiation is not absorbed by the vacuum chamber wall. Substantial shielding (± 50 radiation lengths) is required in some locations to protect the PMTs from background generated by upstream beam losses. In regions where no collimators follow the scanners, small angle scattering monitors have been placed about 10m downstream to use for comparison with the PMT.

The detector linearity must be better than a few percent. A moderate gain, excellent linearity tube was chosen. In order to cross check PMT performance small fast ion chambers were built and installed downstream of some scanners⁶ The linearity of the ADC is also very important.

PERFORMANCE AND CONCLUSIONS

Performance tests have focused on understanding systematic errors. These tests fall into two broad categories: 1) tests made by varying beam size and/or intensity and 2) tests made with different detectors sensing scattered radiation from a single

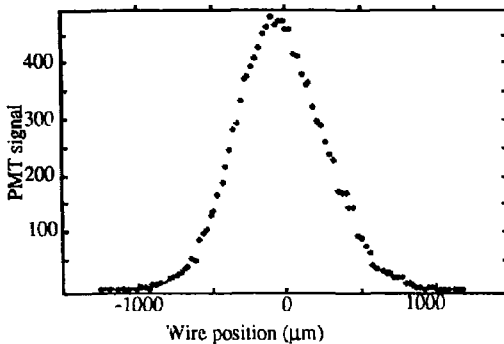

Figure 2: A typical single wire scan. The data are fit with a gaussian with an offset.

wire. Figure 3 shows the beam emittance measured using quadrupole scans⁷ on three different scanners and multiwire scans at 1 GeV and 4.5×10^{10} e⁻/pulse, near the SLC nominal operating intensity. This is a good test of saturation effects since the beam sizes and signal strengths vary considerably over the scan range and from scanner to scanner. These tests were done using the downstream fast ion chamber.

The SLC wire scanners provide beam emittance data that is reliable enough to have already yielded new insights into the performance of the SLC. By late 1991, 32 scanners will be in use (figure 4). Future linear colliders will have a tighter emittance budget and will require improved resolution

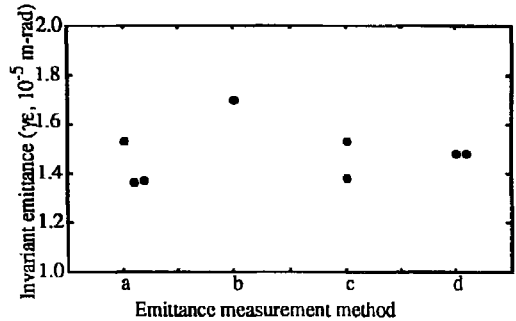

Figure 3: Comparison of emittance measurements made with: multi wire (a) and quadrupole scans (b-d) using different quadrupole magnet / wire scanner combinations. The results are in good agreement.

scanners. Piezo-electric motors, with their very small step size and ultra-high vacuum compatibility, may prove to be an appropriate technology for future wire scanners. Two such scanners are installed for use at the SLC IP.

ACKNOWLEDGEMENTS

We would like to acknowledge the efforts of the linac group for help in commissioning the scanners, the mechanical design and engineering group for mechanical design, A. Tilghman for controls, and C. Field, K. Bouldin and C. Young for PMT testing and data analysis.

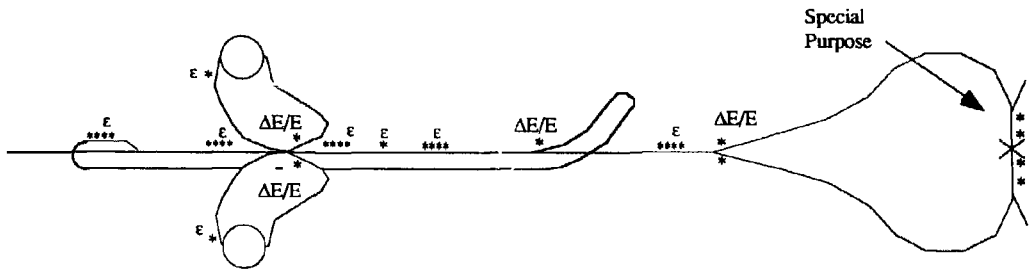

Figure 4: SLC schematic showing the locations of wire scanners. Wire scanners are used for emittance (ϵ), energy spread ($\Delta E/E$) and special purpose functions in the final focus.

¹ R. Jung and R.J. Colchester, 'Development of Beam Profile and Fast Position Monitors for the LEP Injector Linacs', IEEE Trans. Nucl. Sci. NS32-5:1917, 1985.

² R.I. Cutler et. al., 'Performance of Wire Scanner Beam Profile Monitors to Determine the Emittance and Position of High Power CW Electron Beams of the NBS-Los Alamos Racetrack Microtron', Proceedings of the 1987 IEEE Particle Accelerator Conference, p. 625, 1987.

³ K.D. Jacobs et.al., 'The Beam Profile Measurement System at the Bates Linac', Proceedings of the 1989 IEEE Particle Accelerator Conference, p. 1523, 1989.

⁴ L. Sanchez-Chopitea et. al., 'Correlation Plot Facility in the SLC Control System', proceedings of this conference.

⁵ R. Fulton et. al., 'A High Resolution Wire Scanner for Micron Size Profile Measurements at the SLC', Nucl. Instr. Meth. A274:37, 1989.

⁶ D. McCormick, 'Fast Ion Chambers for SLC', proceedings of this conference.

⁷ M.C. Ross et. al., 'Automated Emittance Measurements in the SLC', Proceedings of the 1987 IEEE Particle Accelerator Conference, p. 725, 1987.