

DOE/MC/11076--3072

DE92 001257

An Evaluation of Some Innovative Fragmentation Systems for Oil Shale

Topical Report

**M. Hieta
W.A. Hustrulid**

June 1991

Work Performed Under Cooperative Agreement No.: DE-FC21-86MC11076

For
U.S. Department of Energy
Office of Fossil Energy
Morgantown Energy Technology Center
Morgantown, West Virginia

By
Western Research Institute
Laramie, Wyoming
and
Colorado School of Mines
Golden, Colorado

MASTER

DISCLAIMER

This report was prepared as an account of work sponsored by an agency of the United States Government. Neither the United States Government nor any agency thereof, nor any of their employees makes any warranty, express or implied, or assumes any legal liability or responsibility for the accuracy, completeness or usefulness of any information, apparatus, product, or process disclosed, or represents that its use would not infringe privately owned rights. Reference herein to any specific commercial product, process, or service by trade name, trademark, manufacturer, or otherwise, does not necessarily constitute or imply its endorsement, recommendation, or favoring by the United States Government or any agency thereof. The views and opinions of authors expressed herein do not necessarily state or reflect those of the United States Government or any agency thereof.

This report has been reproduced directly from the best available copy.

Available to DOE and DOE contractors from the Office of Scientific and Technical Information, P.O. Box 62, Oak Ridge, TN 37831; prices available from (615)576-8401, FTS 626-8401.

Available to the public from the National Technical Information Service, U.S. Department of Commerce, 5285 Port Royal Rd., Springfield, VA 22161.

**An Evaluation of Some Innovative
Fragmentation Systems for Oil Shale**

Topical Report

**M. Hieta
W.A. Hustrulid**

Work Performed Under Cooperative Agreement No.: DE-FC21-86MC11076

**For
U.S. Department of Energy
Office of Fossil Energy
Morgantown Energy Technology Center
P.O. Box 880
Morgantown, West Virginia 26507-0880**

**By
Western Research Institute
P.O. Box 3395
University Station
Laramie, Wyoming 82071
and
Colorado School of Mines
Golden, Colorado 80401**

June 1991

SUMMARY

Two aspects of oil shale mining are evaluated in this study. The first part examines blasting against broken rock, that is, buffer blasting as a technique for fragmentation improvement. The findings from a literature review indicate that one of the most important parameters for the fragmentation in buffer blasting is the swell available in the buffer. Some buffer blasting experiments performed in the Soviet Union and in Sweden indicate that blasting toward a buffer of limited swell gives better fragmentation than blasting toward a free space (Volchenko, 1977; Olsson, 1988). Model buffer-blasting experiments, designed to examine the swell in the buffer for satisfactory fragmentation results, were run using large concrete blocks with precast blastholes. The degree of fragmentation achieved in all experiments was poor.

The second part of the study compares mining costs and technical features of a potential new mining system for mining thick, deep oil shale beds—large-hole stoping—using some innovative fragmentation systems (buffer blasting, continuous loading/hauling, and mechanical miners for development) to a conventional room and pillar operation. The comparison of the two mining methods assumes sufficient reserves for a mine life of 30 years. An overburden of 500 meters was also assumed. Average grades and thicknesses of the oil shale were estimated from the Colony Oil Shale Project (Exxon, 1988).

The findings from this study indicate that the operating cost per ton for the large-hole stoping method is lower (\$3.27 per ton) than for the room and pillar mine (\$3.64 per ton). However, because large-hole stoping mines a lower grade material, the operating cost per barrel of oil is much higher (\$7.62 compared to \$4.73 for the room and pillar mine). Therefore, it is concluded that the room and pillar mine is economically more attractive for mining deep oil shale beds. However, large-hole stoping design has a number of advantages compared with the room and pillar design, including higher resource recovery, lower specific development, lower preproduction cost, and lower preproduction interest cost. Other advantages of the large-hole stoping design are underground disposal of spent shale, higher equipment use, and higher automation possibilities.

It is also believed that a spread-out mine, like a room and pillar mine, may need an additional shaft complex. This will add an extra cost to both the capital investment cost and the operating cost for the room and pillar mine. Backfilling of the room and pillar mine is complex, which adds to the operating cost. It is recommended that a cash-flow analysis be performed to evaluate the feasibility of both the large-hole stoping design and the room and pillar design.

OPERATING COSTS AND PRODUCTION RATES FOR LARGE-HOLE STOPING EQUIPMENT

Rock Bolter

The Updated Scott-Ortech Cottonwood Wash Mine Feasibility Study (Synfuels Engineering, 1982) was used to estimate rock-bolting performance. A fully automated rock-bolting unit is assumed. All excavated areas on the overcut and the undercut, except for the loading troughs, are assumed rock bolted with 2.5-m-long resin-grouted bolts in a 1.5- x 1.5-m pattern. The operating cost for a rock-bolter unit was estimated using Mining Cost Service (1988) and the Underground Mining Methods Handbook (1982, p. 1270). All costs have been adjusted to 1990 dollars using an average inflation rate of 2 percent.

Performance Rate: 80 bolts per shift

Operating Cost per Shift:

| | |
|---|-------------|
| 1. Bolts and cement | \$480.00 |
| 2. Consumables (bit, steel, lube, fuel) | 72.00 |
| 3. Maintenance | 21.60 |
| 4. Tires | <u>3.20</u> |

Total Operating Cost per Shift: \$576.80

Operating Cost: \$3.204/m²

Mechanical Miner

Dosco's testing results for oil shale from the Anvil Points Mine were used to estimate the production rate for the mechanical miner. The testing results from Dosco are from an Ertec report (1981) prepared for Phillips Petroleum Company. The specific energy is 18.84 MJ/m³. The machine that is suggested to be used is a Dosco TB 3000 (underground mode). Dosco TB 3000 is a twin-boom road header machine with a cutting power of 250 kW on each boom.

$$\text{Maximum Production Rate (m}^3\text{/hr)} = \frac{\text{cutting power (W)}}{\text{specific energy (J/m}^3\text{)}} \times 3600$$

The calculated maximum production rate is 95.5 m³/hr (210 ton/hr). The estimated average production rate is 52% of the calculated maximum production rate. This gives us an average production rate of 110 ton/hr. Assuming a 50-minute working hour and 8 working hours per shift, the shift production is 730 tons.

Daily Production: 2200 ton/day

Operating Cost:

The operating cost for the mechanical miner is estimated from Exxon/Tosco trial mining of oil shale in the Colony Mine, Parachute, Colorado (Crookston et al., 1982). Costs are adjusted to 1990 dollars using an average inflation rate of 2 percent. The power cost is based on an average power requirement of 2.6 kW•hr/ton and with a cost of \$0.05 per kW•hr. The labor cost is not included in the operating cost. The bit cost is estimated from Ertec (1981).

| | |
|----------------------------------|---------------------|
| 1. Oil and grease | \$0.22 per ton |
| 2. Hoses, chains, fittings, etc. | 0.01 per ton |
| 3. Bit cost | 0.50 per ton |
| 4. Electrical Power | 0.13 per ton |
| 5. Electrical Parts | <u>0.55 per ton</u> |
| Total Operating Cost | \$1.41 per ton |

Fan-Drilling Jumbo

The Underground Mining Methods Handbook (1982, p. 1049) has been used to estimate the operating cost for a electric hydraulic percussion twin-boom fan-drilling jumbo. Costs have been adjusted to 1990 dollars using an average inflation rate of 2 percent. The operating cost includes power, fuel, other consumables, and maintenance costs. The following assumptions have been made: average bit life is estimated at 100 m, average drill steel life is estimated at 600 m, and the time for drilling a trough round is estimated at 1.5 hours. A total of 115 meters (57-mm hole diameter) is drilled for each trough round. Each round pulls 1.5 meters of the trough drift.

Operating Cost:

| | |
|-----------------------------------|--------------|
| 1. Power Cost (1.5 hr) | \$ 8.25 |
| 2. Consumables (bit, steel, etc.) | 97.30 |
| 3. Fuel and Hydraulic Fluid | 1.90 |
| 4. Maintenance | <u>65.00</u> |
| Total Operating Cost per Round: | \$172.45 |
| Total Operating Cost per ton: | \$0.4180 |

Continuous Loader and Feeder Breaker

In this system, it was assumed that the production was limited by the crushing capacity of the feeder breaker. A production of 12,000 tpd for each feeder breaker was assumed feasible. The operating cost for the continuous loader includes power and maintenance costs. The maintenance cost was estimated from the Underground Mining Methods Handbook (1982). The power consumption was estimated from specifications of the Joy loader assuming an average power consumption of 70% of the maximum. The machine availability was estimated at 75%, and a 50-minute working hour was assumed. The power requirement for the feeder breaker was

estimated at 0.216 kW·hr per ton crushed using Bond's theory. It was assumed that the blasted material was crushed down from a size where $k_{80} = 1$ m to a size where $k_{80} = 0.2$ m. The maintenance cost was estimated at 1.2 times the power cost.

Operating Cost Continuous Loader:

| | |
|-----------------------------|---------------------|
| 1. Power | \$ 43 per day |
| 2. Maintenance (\$0.11/ton) | <u>1320</u> per day |
| Total: | \$1363 per day |

Operating Cost Feeder Breaker:

| | |
|----------------|--------------------|
| 1. Power | \$130 per day |
| 2. Maintenance | <u>155</u> per day |
| Total: | \$285 per day |

The total operating cost for this system is \$1648 per day or \$0.1373 per ton loaded and crushed.

ITH Drill

The drilling cost for the ITH Hammer was estimated from the Underground Mining Methods Handbook (1982, p. 1060). The cost was estimated at \$7.00 per meter drilled. The production rate for an ITH drill with 200-mm-diameter holes is estimated at 60 meters per shift including set-up and moves. For the ITH drill with 152-mm-diameter holes, a production rate of 70 meters per shift is assumed.

Conveyors

The conveyor capacities chosen for this plan are listed in Table 9. The operating cost calculations include supply and equipment operating cost. The supply cost consists of the power cost for operating the conveyor at the required average capacities during three shifts per day. The power requirement for each belt is estimated using the graphical method for average tons per day and average lengths of the belts during the mine life. The equipment operating cost is estimated from the Bureau of Mines Cost Estimating System Handbook. The cost has been adjusted to 1990 dollars by an average inflation rate of 2 percent. The following assumptions were made for the power calculations: (1) minimum belt width 0.76 m, (2) 25° surcharge angle, (3) 35° angle of repose of rubblized oil shale, (4) 10 percent lump, 20 cm maximum lump size, and (5) 1440 kg/m³ material weight rubblized. The operating cost for conveyor haulage is estimated at \$3930 per day. The capital cost for purchase of the conveyor equipment has been estimated using the Bureau of Mines Cost Estimating System Handbook. It is assumed that the main conveyor on both the overcut and the undercut is being extended every year or every second year. The prices are adjusted to 1990 dollars using an average inflation rate of 2 percent. All conveyors have a life expectancy of 20 years. The conveyor costs are presented in Tables A1 and A2.

Table A1. Conveyor Operating Cost

| Conveyor | No. of Belts | kW•hr per day per unit | Supply Cost (\$/unit) | Equipment Cost (\$/unit) | Total Cost (\$) |
|-----------------|--------------|------------------------|-----------------------|--------------------------|-----------------|
| Main UC, 1400 m | 1 | 9200 | 460 | 1708 | 2168 |
| Main UC, 470 m | 1 | 3200 | 160 | 578 | 738 |
| Stope UC, 70 m | 4 | 280 | 14 | 40 | 216 |
| Snake UC, 200 m | 2 | 130 | 6.50 | 36.9 | 87 |
| Main OC, 1400 m | 1 | 710 | 35.5 | 454.6 | 490 |
| Main OC, 470 m | 1 | 250 | 12.5 | 153.8 | 166 |
| Stope OC, 70 m | 2 | 80 | 4.0 | 12.9 | 34 |
| Snake OC, 140 m | 1 | 104 | 5.2 | 25.7 | 31 |

OC = overcut

UC = undercut

Main = main conveyor

Stope = extendable stope conveyor

Snake = DME's belt bender snake

Note that the operating cost is based on average belt lengths during the mine life.

Table A2. Conveyor Capital Cost (\$1000)

| Production Year, Capital Cost | Preprod | Year 5 | Year 6 | Year 7 | Year 8 | Year 9 | Year 10 | Year 11 | Year 12 |
|---|--------------|--------------|--------------|--------------|--------------|--------------|--------------|--------------|--------------|
| Main Conveyor UC, 440 m | 1,470 | | | | | | | | |
| Main Conveyor OC, 440 m | 476 | | | | | | | | |
| Bendable Snake UC, 200 m | 138 | 138 | | | | | | | |
| Bendable Snake OC, 140 m | 98.5 | | | | | | | | |
| Stope Conveyors (4) UC, 70 m | | 536 | | | | | | | |
| Stope Conveyors (2) OC, 70 m | | 102.4 | | | | | | | |
| Extension Main UC, 310 m | | 941 | 941 | 941 | 941 | 941 | 941 | 941 | 941 |
| Extension Main OC, 310 m | | 305.5 | 305.5 | 305.5 | 305.5 | 305.5 | 305.5 | 305.5 | 305.5 |
| Main (Stope Gather) UC, 155 m | | 489 | | | | | | | |
| Main (Stope Gather) OC, 155 m | | 158.7 | | | | | | | |
| Extension of Stope Gather Conveyor UC, 350 m | | | 1,055 | 1,055 | 1,055 | | | | |
| Extension of Stope Gather Conveyor OC, 350 m | | | 342.6 | 343.6 | | | | | |
| Extension of Stope Gather Conveyor UC, 175 m | | | | | 548.3 | | | | |
| Extension of Stope Gather Conveyor OC, 175 m | | | | | 178.0 | | | | |
| TOTAL CAPITAL COST (\$1000) PER YEAR | 2,183 | 2,671 | 2,644 | 2,644 | 1,973 | 1,247 | 1,247 | 1,247 | 1,247 |

Note that the conveyor capital cost is based on actual lengths of the conveyors during the mine life.

BLASTING LAYOUTS AND ESTIMATED COSTS FOR LARGE-HOLE STOPPING

Blasting Cost for the Trough

Each trough round pulls 1.5 m of the trough. The cost for consumables is estimated from Mining Cost Service (1988). Costs are adjusted to 1990 dollars using an average inflation rate of 2 percent. The specific charge is 1.2 kg/m³ of rock.

Blasting Cost per Round (115 drillmeter):

| | |
|---------------------------|--------------|
| 1. ANFO (225 kg) | \$ 107.00 |
| 2. 10 primers | 8.00 |
| 3. 10 caps (delay 1-10) | 34.00 |
| 4. Detonating cord (55 m) | <u>21.50</u> |
| Blasting Cost per Round: | \$ 170.50 |

Blasting Cost for Each Trough: \$13,640

Production Blasting

The hole diameter for production blasting is selected at 200 mm. A total of 135 holes (81 wall holes) is drilled for each stope. The holes are charged with slurry explosive (1200 kg/m³). All holes are stemmed with sand. The hole diameter for the wall holes is 100 mm because a plastic pipe is placed in the drill hole before charging. The cost calculation is based on prices in Mining Cost Service (1988) and adjusted to 1990 dollars using an average inflation rate of 2 percent.

Blasting Cost Production Hole:

| | |
|-----------------------------------|-------------|
| 1. Slurry (2800 kg) | \$1,981.00 |
| 2. Boosters 2 x 1/2 lb | 3.50 |
| 3. Caps (2) and 150 ft Nonel tube | 6.30 |
| 4. Ignition Cord 10 m | 4.10 |
| 5. Sand stemming (250 kg) | <u>0.30</u> |
| Cost per Hole: | \$1,995.20 |

Blasting Cost Wall Holes:

| | |
|-----------------------------------|-------------|
| 1. Slurry (707 kg) | \$495.00 |
| 2. 75 m plastic pipe | 342.00 |
| 3. Boosters 2 x 1/2 lb | 3.50 |
| 4. Caps (2) and 150 ft Nonel tube | 6.30 |
| 5. Ignition Cord 10 m | 4.10 |
| 6. Sand 3.5 ton | <u>3.50</u> |
| Cost per Hole: | \$854.40 |

The total blasting cost is estimated at \$177,000 per stope.

Slot Blasting

The hole diameter for the slot blasting is 152 mm. A total number of 24 holes is assumed required for a slot of 15 x 20 m. The holes are assumed charged with slurry and stemmed with sand, as are the production holes. The holes are blasted one by one in four intervals of the total length. The blasting cost was estimated using Mining Cost Service (1988). Costs have been adjusted to 1990 dollars using an average inflation rate of 2 percent.

Blasting Cost per Hole:

| | |
|--------------------------|-------------|
| 1. Slurry (1372 kg) | \$970.00 |
| 2. Boosters (4 x 1/2 lb) | 7.00 |
| 3. Caps and Nonel tube | 25.00 |
| 4. Conical Plugs | 8.00 |
| 5. Ignition Cord | 4.10 |
| 6. Stemming | <u>0.60</u> |
| Total Cost per Hole: | \$1,014.70 |

The estimated completion time for blasting of the slot is 8 shifts. The total blasting cost of the slot is \$24,400.

Blasting plans for the trough and production are shown in Figures A1 and A2. The plan for the stope slot is shown in Figure A3.

BLASTING LAYOUT FOR THE TROUGH

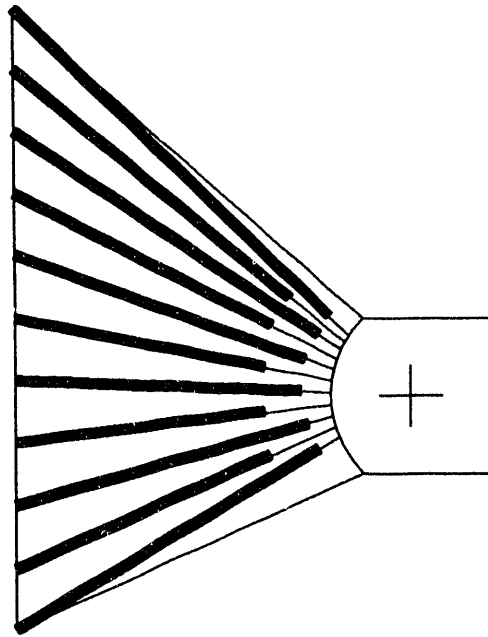

HOLE DIAMETER: 57 mm
POWDER FACTOR: 0.7 kg/m
BURDEN: 1.5 m
SPACING: 2.0 m
AVERAGE HOLE LENGTH: 10.5 m

Figure A1. Blasting Plan for the Trough

PRODUCTION BLASTING LAYOUT

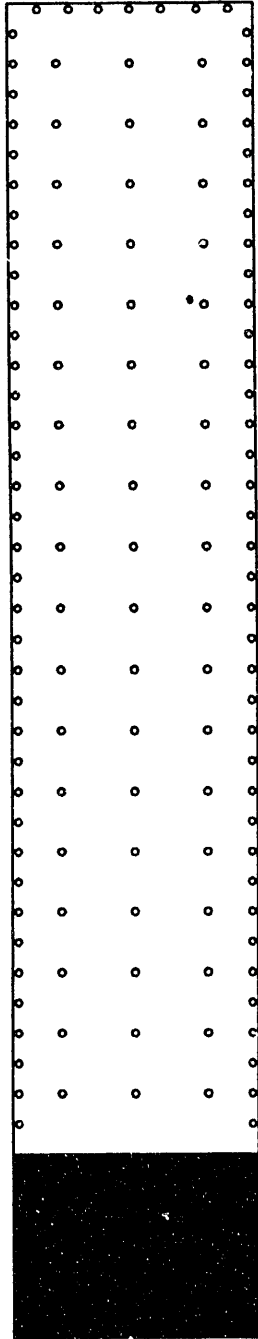

No. of Drill Holes : 135

No. of Wall Holes : 81

Hole Diameter : 200 mm

Spacing : 6 m for production holes and 2.5 m for wall holes

Burden : 5 m for production holes and 3.5 m for wall holes

Figure A2. Production Blasting Plan

LAYOUT FOR THE STOPE SLOT

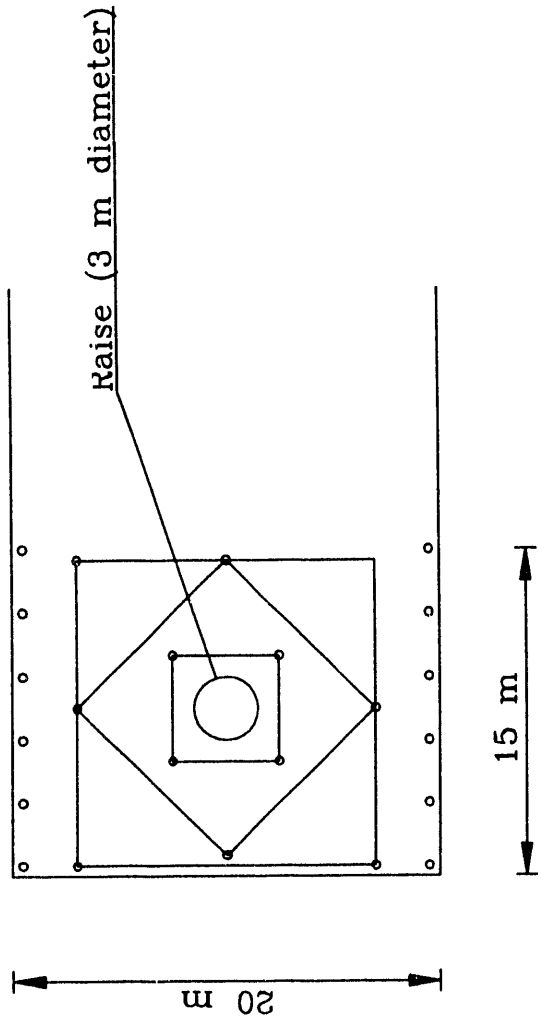

- No. of Holes : 24
- Hole diameter : 152 mm
- Maximum Burden : 5 m
- Powder Factor : 20.2 kg/m drill hole
- Advance : 15 m per shift

Figure A3. Plan for the Stope Slot

PREPRODUCTION COST ESTIMATES FOR LARGE-HOLE STOPING

Raises

The Bureau of Mines Cost Estimating System Handbook (USBM CEH, 1987) has been used for estimating completion times and costs. The raises are assumed drilled down and reamed up. The total cost has been adjusted to 1990 dollars using an average inflation rate of 2 percent.

Raise Connecting the Overcut with the Skip-Loading Pocket:

| | |
|------------------|--------------|
| Raise diameter: | 3 m |
| Raise length: | 100 m |
| Advance rate: | 1.06 m/shift |
| Completion time: | 95 shifts |
| Total cost: | \$49,000 |

The raise is developed by a contractor working two shifts per day. The total cost includes labor, supplies, and equipment operating costs.

Stope Raises:

| | |
|------------------|--------------|
| Raise diameter: | 3 m |
| Raise length: | 89 m |
| Advance rate: | 1.06 m/shift |
| Completion time: | 84 shifts |
| Total cost: | \$31,000 |

The raise is developed by the mines own personnel and equipment. The total cost includes supplies and equipment operating costs. The labor cost is excluded.

Shafts

The updated Scott-Ortech Cottonwood Wash Mine Feasibility Study (1982) has been used for estimated shaft-sinking and shaft-construction times done by the contractor. All costs have been adjusted to 1990 dollars using an average inflation rate of 2 percent.

Production Shaft:

The production shaft is a 9-m-diameter concrete-lined shaft. The costs include two single-drum hoists, four 60-ton skips, headframe foundation, head frame, skiploading pocket, and hoist house.

| | |
|----------------------------|--------------|
| Estimated completion time: | 21 months |
| Total equipment cost: | \$14,750,000 |
| Sinking cost: | \$13,595,000 |

Service Shaft:

The service shaft is a 9-m-diameter concrete-lined shaft. The costs include one single-drum hoist, cage, head frame, head frame foundation, and shaft station.

| | |
|----------------------------|--------------|
| Estimated completion time: | 26 months |
| Total equipment cost: | \$5,000,000 |
| Sinking cost: | \$12,843,000 |

Ventilation Shafts:

The ventilation shafts are 9 and 7 m in diameter. The sinking cost includes a ventilation station.

| | |
|--------------------------------------|--------------|
| Estimated completion time (exhaust): | 11 months |
| Estimated completion time (intake): | 11 months |
| Sinking cost (exhaust): | \$12,606,000 |
| Sinking cost (intake): | \$7,207,000 |

Transportation Drifts Developed by the Contractor

Five hundred meters of transportation drift is developed on both the overcut and the undercut by a contractor operating two shifts per day. The drift development is assumed done by drilling and blasting. The overcut drifts are 6 by 6 meters and the undercut drift is 6 by 5 meters. The total cost for the drift development and the completion time have been estimated using Bureau of Mines Cost Estimating System Handbook (1987). The cost includes labor cost, supply cost, and equipment operating cost. The drift cycle includes drilling, loading, blasting, venting, mucking, scaling, rockbolting, lunch, and travel.

Overcut Drift:

| | |
|-------------------------|------------|
| Drift length: | 2 x 250 m |
| Tons of rock excavated: | 39,600 ton |
| Advance rate: | 10 m/day |
| Completion time: | 100 shifts |
| Total cost: | \$522,500 |

Undercut Drift:

| | |
|-------------------------|------------|
| Drift length: | 2 x 250 m |
| Tons of rock excavated: | 33,000 ton |
| Advance rate: | 10 m/day |
| Completion time: | 100 shifts |
| Total cost: | \$469,000 |

Stope and Drift Development on the Overcut

A total of 100,100 ton of transportation drift (6 x 6 m) and 262,700 ton of stopes are developed as preproduction. Two mechanical miners are assumed used for development of the drifts and stopes. When the drift development is completed, development of the stopes starts. The completion time is estimated from a production rate of 730 ton per shift and mechanical miner. The total cost includes excavation cost with mechanical miners, roof-bolting cost, and conveying cost. The conveying cost is estimated from Bureau of Mines Cost Estimating System Handbook (1987). Labor costs are excluded.

| | |
|-------------------------|-------------|
| Tons of rock excavated: | 362,800 ton |
| Completion time: | 248 shifts |

Costs:

| | |
|---|---------------|
| Excavating cost: | \$511,500 |
| Rock bolting cost (40,030 m ²): | 128,100 |
| Conveying cost: | <u>13,600</u> |
| Total Cost: | \$653,200 |

Estimation of Preproduction Cost for Conveyor Haulage

The cost is estimated from Bureau of Mines Cost Estimation System Handbook (1987). Maintenance costs are adjusted to 1990 dollars using an average inflation rate of 2 percent. The operating cost includes daily operating cost and maintenance cost. Labor costs are excluded.

Overcut:

| | |
|---------------------------|-----------|
| Average haulage rate: | 2900 tpd |
| Average hauling distance: | 440 m |
| Total cost: | \$110/day |

Undercut:

| | |
|---------------------------|-----------|
| Average haulage rate: | 2900 tpd |
| Average hauling distance: | 440 m |
| Total cost: | \$110/day |

Transportation Drift, Trough Drift, and Crosscut Preproduction on the Undercut

A total of 116,300 tons of transportation drift (6 x 5 m) and 111,300 tons of trough drifts and crosscuts (5 x 5 m) are developed as preproduction. One mechanical miner is assumed used for preproduction. The completion time is estimated from a production rate of 730 ton/shift operating two shifts per day. The total cost includes excavation cost with mechanical miners, roof-bolting cost, and conveying cost. Labor costs are excluded.

Transportation Drifts, Trough Drifts, and Crosscuts:

| | |
|-------------------------|---------------|
| Tons of rock excavated: | 227,600 |
| Completion time: | 311 shifts |
| Costs: | |
| Excavating: | \$320,900 |
| Roof bolting: | 187,400 |
| Conveying cost: | <u>17,100</u> |
| Total cost: | \$525,400 |

Troughs

A total of 960 m of troughs (8) are developed as preproduction. Trough drift development is assumed done with conventional drilling and blasting. The completion time is estimated from an advance rate of two rounds per shift (3.0 m) per fan-drilling jumbo. The total cost includes drilling, blasting, loading, and crushing. Conveying costs are included in the cost for transportation drift preproduction on the undercut. Labor costs are not included.

Cost per trough (120 m):

| | |
|-------------------------------------|--------------|
| Drilling: | \$13,800 |
| Blasting: | 13,640 |
| Loading and crushing: | <u>4,500</u> |
| Total cost per trough (33,000 ton): | \$31,940 |

Ancillary Facilities

The cost for the ancillary facilities has been estimated using Cameron Engineers Report (1977). Costs have been adjusted to 1990 dollars using an average inflation rate of 2 percent.

Cost (1977):

| | |
|---|---------------|
| Maintenance and supply shop: | \$130,000 |
| Lunchroom, lamproom, and sanitary facility: | 2,000,000 |
| Explosive magazines (2): | <u>60,000</u> |
| Total cost (1977): | \$2,190,000 |
| Total cost (1990): | \$2,833,000 |

MISCELLANEOUS OPERATING AND CAPITAL COSTS FOR LARGE-HOLE STOPPING

Hoisting

The following assumptions have been made for the hoisting system:

| | |
|--|----------------------|
| Acceleration stop to creep speed: | 0.6 m/s ² |
| Acceleration creep speed to full speed: | 1.0 m/s ² |
| Retardation full speed to approach speed: | 1.0 m/s ² |
| Retardation approach speed to creep speed: | 1.0 m/s ² |
| Retardation creep speed to stop: | 0.6 m/s ² |
| Maximum full speed: | 13 m/s |
| Creep speed: | 0.6 m/s |
| Approach speed: | 3 m/s |
| Hoisting distance: | 650 m |

Table A3. Production Hoist Duty Schedule for Large-Hole Stopping

| | Distance (m) | Time (s) |
|-------------------------------|-----------------|-------------|
| Acceleration: stop to creep | 0.6 | 1.0 |
| Run at creep speed | 3.0 | 5.0 |
| Acceleration to full speed | 84.3 | 12.4 |
| Run at full speed | 462.2 | 35.6 |
| Retardation to approach speed | 80.0 | 10.0 |
| Run at approach speed | 12.0 | 4.0 |
| Retardation to creep speed | 4.3 | 2.4 |
| Run at creep speed | 3.0 | 5.0 |
| Retardation creep to stop | 0.6 | 1.0 |
| Rest (load/dump) | --- | 30.0 |
| Total (distance,time) | 650 | 107 |

The production rate for the two hoists is based on 22 hr/day for hoisting oil shale. Two hours per day are allowed for hoisting of men and material. The total power requirement for the two hoists is estimated at 13,400 kW. It was assumed that the hoists will operate a maximum of 24 hr/day for full production and a maximum of 5 hr/day during preproduction. The operating cost was calculated using a power cost of \$0.05/kW•hr. Maintenance cost was estimated at 10 percent of the power cost.

Production operating cost:

| | |
|------------------------------|--------------|
| Power cost: | \$16,100 |
| Maintenance cost: | <u>1,600</u> |
| Total cost per day: | \$17,700 |
| Skip size: | 60 ton |
| Maximum production rate: | 89,000 tpd |
| Cost of hoisting 75,000 tpd: | \$14,900 |

Preproduction operating cost:

| | |
|--------------------------------------|------------|
| Power cost: | \$3,250 |
| Maintenance cost: | <u>325</u> |
| Total cost per day: | \$3,575 |
| Maximum production rate: | 20,200 tpd |
| Cost of hoisting 4,220 tpd (year 3): | \$747/day |
| Cost of hoisting 2,460 tpd (year 4): | \$435/day |

Ventilation

The ventilation cost (operating and capital) was estimated using Bureau of Mines Cost Estimating Handbook System (1987). The estimated ventilation requirement was based on the following assumptions:

- 2.83 m³/min per diesel hp
- 0.1 m/s stope ventilation velocity
- 0.3 m/s minimum airway velocity on the undercut
- 6000 m³/s for shop and shaft pillar areas
- 25 percent for leaks and losses

Table A4. Air Requirement for Large-Hole Stopping

| Equipment | Air Requirement (m ³ /min) |
|-----------------------------|---------------------------------------|
| ITH Drills (12) | 432 |
| Raise Borers (5) | 180 |
| Fan-Drill Jumbo (2) | 12 |
| Air Motors (maximum 500 hp) | 420 |
| Drainage Pump | 6 |
| Leaks and Losses | <u>105</u> |
| Total | 1,155 |

| | |
|-----------------|-------------|
| Capital cost: | \$1,410,000 |
| Operating cost: | \$3,950/day |

Water Supply and Drainage

The water supply cost (operating and capital) has been estimated assuming a demand of 2,000 m³/day. The drainage cost was estimated assuming a pumping rate of 10,000 m³/day. Bureau of Mines Cost Estimating System Handbook was used for estimating the costs. Costs were adjusted to 1990 dollars using an average inflation rate of 2 percent. The operating cost includes equipment operating cost and supplies.

Operating cost:

| | |
|----------|-------------|
| Supply | 108/day |
| Drainage | \$1,485/day |

Capital cost:

| | |
|----------|-----------|
| Supply | \$304,000 |
| Drainage | \$667,500 |

Electrical Capital Cost

The electrical capital cost was estimated using U.S. Bureau of Mines Cost Estimating Handbook. The maximum demand for the mine was estimated at 26,000 kW. The load factors are from Scott-Ortech's Cottonwood Wash Mine Feasibility Study (Synfuels Engineering, 1982). The cost has been adjusted to 1990 dollars using an average inflation rate of 2 percent. The capital cost is estimated at \$1,497,000.

Table A5. Electrical Power Requirement for Large-Hole Stopping

| Equipment | Unit kW | Load Factor | Total kW |
|-----------------------|---------|-------------|----------|
| Production Hoists (2) | 6,700 | 0.8 | 10,700 |
| Service Hoist (1) | 485 | 0.8 | 388 |
| Fan Drill Jumbo (2) | 60 | 0.6 | 72 |
| ITH Drill (12) | 60 | 0.6 | 432 |
| Mechanical Miners (5) | 746 | 0.7 | 2,600 |
| Continuous Loader (6) | 149 | 0.7 | 627 |
| Raise Borers (5) | 250 | 0.7 | 875 |
| Feeder Breakers (6) | 187 | 0.7 | 785 |
| Conveyors | 625 | 0.7 | 438 |
| Roof Bolters (3) | 30 | 0.7 | 63 |
| Compressor (4) | 224 | 1.0 | 896 |
| Ancillary Fans | 60 | 0.9 | 810 |
| Pumps | 373 | 1.0 | 373 |
| Workshop | 110 | 0.7 | 77 |
| Lighting | 700 | 1.0 | 700 |
| Misc., Losses (30%) | | | 5,950 |
| TOTAL | | | ~26,000 |

Fuel Consumption

The use factors are from Scott-Ortech Cottonwood Wash Mine Feasibility Study (Synfuels Engineering, 1982). The fuel price was estimated at \$1.0/gallon, which gives a daily fuel cost of \$595. During the preproduction, the daily fuel cost is estimated at \$140/day.

Backfill Cost

The backfill operating cost was estimated to \$0.93/m³ filled. The cost was found in the Underground Mining Methods Handbook (1982, p. 583). The cost (from 1979) was adjusted to 1990 dollars using an average inflation rate of 2 percent.

Table A6. Fuel Requirement for Large-Hole Stopping

| Diesel Equipment | gal/hr | Use Factor | Total gal/day |
|---------------------------|--------|------------|---------------|
| Slurry Loading Trucks (3) | 3.0 | 0.6 | 129.6 |
| Service Trucks (3) | 3.0 | 0.5 | 108.0 |
| Water Truck (3) | 3.0 | 0.4 | 86.4 |
| ANFO Loading Truck (1) | 3.0 | 0.2 | 14.4 |
| Lube and Fuel Truck (3) | 3.0 | 0.3 | 64.8 |
| Scissors Lift Truck (3) | 3.0 | 0.3 | 64.8 |
| Manning Trucks (3) | 3.0 | 0.1 | 21.6 |
| Backfill pumps (4) | 0.5 | 0.7 | 33.6 |
| Tramming, etc. | | | 72.0 |
| TOTAL | | | 595.2 |

DEPRECIATION SCHEDULE FOR LARGE-HOLE STOPPING

Table A7. Depreciation Schedule for Large-Hole Stopping

| Depreciation Period (yr) | Type of Equipment | Total Investment (\$1000) | Annual Depreciation Cost (\$1000) |
|--------------------------|--|---------------------------|-----------------------------------|
| 20 | Mech. Miners (5) | 6,250 | 313 |
| 10 | ITH Drill (12) | 2,461 | 246 |
| 10 | Continuous Loader (6) | 2,303 | 230 |
| 20 | Feed. Breakers(6) | 3,000 | 150 |
| 10 | Drill Jumbo (2) | 576 | 58 |
| 10 | Slurry Trucks (3) | 1,200 | 120 |
| 20 | Conveyor Belts | 14,609 | 730 |
| 10 | Raise Borers (5) | 7,345 | 735 |
| 10 | Service Truck (3) | 186 | 19 |
| 10 | Roof Bolters (3) | 1,554 | 155 |
| 10 | Anfo Truck (1) | 82 | 8 |
| 10 | Water Trucks (3) | 183 | 18 |
| 10 | Lube & Fuel Trucks (3) | 245 | 25 |
| 10 | Scissors Lift Trucks (3) | 212 | 21 |
| 10 | Manning Trucks (3) | 212 | 21 |
| 20 | Backfill Pump (4) | 63 | 3 |
| 10 | Ambulance (2) | 160 | 16 |
| 10 | Equip. Shop | 1,300 | 130 |
| 30 | Preproduction Development (including interest) | 105,755 | 3,525 |
| | TOTAL | | 6,523 |

Table A8. Average Annual Interest Cost for Large-Hole Stoping

| Depreciation Period (yr) | Total Investment (\$1000) | Yearly Interest Cost (\$1000) |
|-----------------------------|------------------------------|----------------------------------|
| 10 | 18,019 | 892 |
| 20 | 23,922 | 1,130 |
| 30 | 105,755 | 4,918 |
| Working Capital | 18,478 | 1,663 |
| TOTAL | | 8,603 |

APPENDIX B
Supplementary Material for
Room and Pillar Mining

CONTENTS OF APPENDIX B

| | <u>Page</u> |
|--|-------------|
| LIST OF TABLES AND FIGURES..... | B-3 |
| OPERATING COSTS AND PRODUCTION RATES FOR ROOM AND PILLAR EQUIPMENT..... | B-4 |
| Rock Bolter..... | B-4 |
| Percussion Drilling Jumbo..... | B-4 |
| ITH Drill..... | B-5 |
| Twin-Boom Rotary Jumbo..... | B-5 |
| Rubber-Tired Loaders..... | B-5 |
| Rubber-Tired Haulage Trucks..... | B-6 |
| BLASTING LAYOUTS AND ESTIMATED COSTS FOR ROOM AND PILLAR..... | B-6 |
| Blasting Cost for Mains and Submains..... | B-6 |
| Blasting of the Heading..... | B-7 |
| Blasting of the Bench..... | B-7 |
| PREPRODUCTION COST ESTIMATES FOR ROOM AND PILLAR..... | B-11 |
| Shafts..... | B-11 |
| Transportation Drifts Developed by the Contractors..... | B-11 |
| Main and Submain Preproduction..... | B-12 |
| Development of the First Mining Section..... | B-12 |
| Development of the Second, Third, and Fourth Mining Sections..... | B-12 |
| Ancillary Facilities..... | B-13 |
| MISCELLANEOUS OPERATING AND CAPITAL COSTS FOR ROOM AND PILLAR..... | B-13 |
| Hoisting..... | B-13 |
| Ventilation..... | B-15 |
| Compressed Air..... | B-16 |
| Water Supply and Drainage..... | B-16 |
| Electrical Capital Cost..... | B-17 |
| Fuel Consumption..... | B-17 |
| Crushing Operating and Capital..... | B-18 |
| Surface Disposal of Spent Shale..... | B-18 |
| DEPRECIATION SCHEDULE FOR ROOM AND PILLAR..... | B-19 |

LIST OF TABLES AND FIGURES

| <u>Table</u> | <u>Page</u> |
|---|--------------------|
| B1. Production Hoist Duty Schedule for Room and Pillar..... | B-14 |
| B2. Air Requirement for Room and Pillar..... | B-16 |
| B3. Electrical Power Requirement for Room and Pillar..... | B-17 |
| B4. Fuel Requirement for Room and Pillar..... | B-17 |
| B5. Depreciation Schedule for Room and Pillar..... | B-19 |
| B6. Average Annual Interest Cost for Room and Pillar..... | B-19 |

| <u>Figure</u> | <u>Page</u> |
|---|--------------------|
| B1. Blasting Layout for Mains and Submains..... | B-8 |
| B2. Blasting Layout for the Heading..... | B-9 |
| B3. Blasting Layout for the Benching..... | B-10 |

OPERATING COSTS AND PRODUCTION RATES FOR ROOM AND PILLAR EQUIPMENT

Rock Bolter

The updated Scott-Ortech Cottonwood Wash Mine Feasibility Study (Synfuels Engineering, 1982) has been used for estimating rock-bolting performance. A fully automated rock-bolting unit is assumed used. All excavated areas are assumed rock-bolted with 2.5-m-long resin-grouted bolts in a 1.5- x 1.5-m pattern. The operating cost for a rock-bolter unit has been estimated using Mining Cost Service (1988) and the Underground Mining Methods System Handbook (1982, p. 1270). All costs are adjusted to 1990 dollars using an average inflation rate of 2 percent.

Performance Rate: 80 bolts per shift

Operating Cost per Shift:

| | |
|---|-------------|
| 1. Bolts and Cement | \$480.00 |
| 2. Consumables (bit, steel, lube, fuel) | 72.00 |
| 3. Maintenance | 21.60 |
| 4. Tires | <u>3.20</u> |
| Total Operating Cost per Shift | \$576.80 |

Operating Cost per m²: \$3.204

Percussion-Drilling Jumbo

The Underground Mining Methods Handbook (1982, p. 1049) has been used to estimate the operating cost for a percussion twin-boom drilling jumbo. Costs are adjusted to 1990 dollars by an average inflation rate of 2 percent. The operating cost includes power, fuel, other consumables, and maintenance costs. The following assumptions were made: (1) average bit life is estimated at 100 m, and (2) average drill steel life is estimated at 600 m. The time for drilling each round for the mains and the submains is estimated at 3.0 hours. A total of 238 meters with a hole diameter of 57 mm is drilled in each round. Each round pulls 5 m of the drift.

Operating Cost:

| | |
|-----------------------------------|----------|
| 1. Power Cost (3.0 hr) | \$ 16.50 |
| 2. Consumables (bit, steel, etc.) | 210.36 |
| 3. Fuel and Hydraulic Fluid | 3.93 |
| 4. Maintenance | 72.80 |
| Total Operating Cost per Round | \$294.59 |
| Total Operating Cost per Ton | \$0.3348 |

ITH Drill

The drilling cost for the ITH hammer was estimated from Underground Mining Methods Handbook (p. 1060). The cost was estimated at \$3.5 per meter drilled. The production rate for a ITH drill with 114-mm-diameter holes was estimated at 90 m/shift including set-up and moves.

Twin-Boom Rotary Jumbo

The drilling cost for the twin-boom rotary jumbo was estimated from Underground Mining Methods Handbook (p. 1060). The cost was estimated to \$3.5 per meter drilled. The production rate for a ITH drill with 114-mm-diameter holes was estimated at 80 meters per hour including set-up and moves.

Rubber-Tired Loaders

The loaders selected for the production and the development operation are CAT 992C and CAT 988B. The operation cost and cycle time for each type of loader were estimated with the use of the CAT Handbook. Selected bucket sizes were 10.4 m³ for the 992C loader and 5.5 m³ for the 988B loader. A bucket fill factor of 0.8 was used for the calculations. A density (loose) of 1.4 ton/m³ was assumed for the oil shale. A fifty-minute working hour and an availability of 80 percent were assumed. An average haulage distance of 30 m for the production and 50 m for the development was assumed in the cycle time calculations.

Production (992C):

| | |
|--------------------|------------|
| Cycle time: | 0.79 min |
| Hourly production: | 735 ton |
| Daily production: | 14,100 ton |

Development (988B):

| | |
|--------------------|-----------|
| Cycle time: | 0.86 min |
| Hourly production: | 358 ton |
| Daily production: | 6,900 ton |

Operating Cost per Hour:

| | <u>992C</u> | <u>988B</u> |
|---|-------------|-------------|
| 1. Fuel | \$20.00 | \$12.00 |
| 2. Lube, oil, filter, grease | 1.22 | 0.70 |
| 3. Tires (2000 hr) | 10.00 | 8.00 |
| 4. Repair, reserve (no labor included) | <u>8.70</u> | <u>5.40</u> |
| Operating Cost per Hour per Loader: | 39.92 | 26.11 |
| Operating Cost per Ton: | \$0.0543 | \$0.0729 |

Rubber-Tired Haulage Trucks

CAT 550B dump trucks (50 ton) were selected for both the development operation and the production. The cycle time and operating cost for the trucks were estimated using the CAT Handbook. The truck is calculated to carry 42.7 tons of oil shale per cycle. The average haulage distances during the production period (30 years), development period (30 years), and the preproduction period (6 years) were calculated using the weighted average technique proportional to the tonnage mined. A 50-min working hour was assumed as well as an availability of 80 percent.

Production:

| | |
|----------------------------|---------------------|
| Loader: | CAT 992C |
| Tons mined per day: | 40,100 |
| Average haulage distance: | 3730 m |
| Production rate per truck: | 128 tph or 2460 tpd |

Development:

| | |
|----------------------------|---------------------|
| Loader: | CAT 988B |
| Tons mined per day: | 34,900 |
| Average haulage distance: | 3670 m |
| Production rate per truck: | 115 tph or 2200 tpd |

Preproduction:

| | |
|----------------------------|---------------------|
| Loader: | CAT 988B |
| Average haulage distance: | 1090 m |
| Production rate per truck: | 197 tph or 3790 tpd |

Operating Cost per Truck per Hour:

| | |
|---|-------------|
| 1. Fuel | \$8.50 |
| 2. Lube, oil, filter, grease | 0.84 |
| 3. Tires (4000 hr) | 4.50 |
| 4. Repair, reserve (no labor excluded) | <u>4.68</u> |
| Operating Cost per Truck per Hour: | \$18.52 |

BLASTING LAYOUTS AND ESTIMATED COSTS FOR ROOM AND PILLAR

Blasting Cost for Mains and Submains

Each trough round pulls 5 m of the drift. The cost for consumables is estimated from Mining Cost Service (1988). Costs are adjusted to 1990 dollars using an average inflation rate of 2 percent. The specific charge is 1.22 kg/m³ of rock, and ANFO is the explosive.

Blasting Cost per Round (238 drillmeter):

| | |
|---------------------------|--------------|
| 1. ANFO (489 kg) | \$232.60 |
| 2. 45 primers | 35.80 |
| 3. 45 caps (delay 1-10) | 153.00 |
| 4. Detonating cord (60 m) | <u>24.00</u> |
| Total Cost per Round | \$445.40 |
| Cost per Ton of Rock | \$ 0.506 |

Blasting of the Heading

The selected hole diameter for development blasting is 114 mm. A total of 22 holes is blasted in each round. The holes are charged with ANFO (900 kg/m³). All holes will be stemmed with sand. The cost calculation is based on prices in Mining Cost Service (1988). All costs are adjusted to 1990 dollars using an average inflation rate of 2 percent.

Blasting Cost per Round (165 drillmeter):

| | |
|---------------------------|--------------|
| 1. ANFO (1400 kg) | \$665.80 |
| 2. 22 primers | 17.50 |
| 3. 22 caps (delay 1-10) | 74.80 |
| 4. Detonating cord (30 m) | <u>12.00</u> |
| Total Cost per Round | \$770.10 |
| Cost per Ton of Rock | \$ 0.347 |

Blasting of the Bench

The hole diameter for production blasting is selected as 114 mm. A total of 6 holes is blasted in each row. The holes are charged with ANFO (900 kg/m³). All holes will be stemmed with sand. The cost calculation is based on prices in Mining Cost Service (1988). All costs are adjusted to 1990 dollars using an average inflation rate of 2 percent.

Blasting Cost per Row (60 drillmeter):

| | |
|---------------------------|--------------|
| 1. ANFO (443 kg) | \$210.68 |
| 2. 6 primers | 4.77 |
| 3. 6 caps (delay 1-10) | 20.40 |
| 4. Detonating cord (30 m) | <u>12.00</u> |
| Total Cost per Row | \$247.85 |
| Cost per Ton of Rock | \$ 0.224 |

Layouts for the blasting are shown in Figures B1 through B3.

BLASTING LAYOUT MAINS AND SUBMAINS

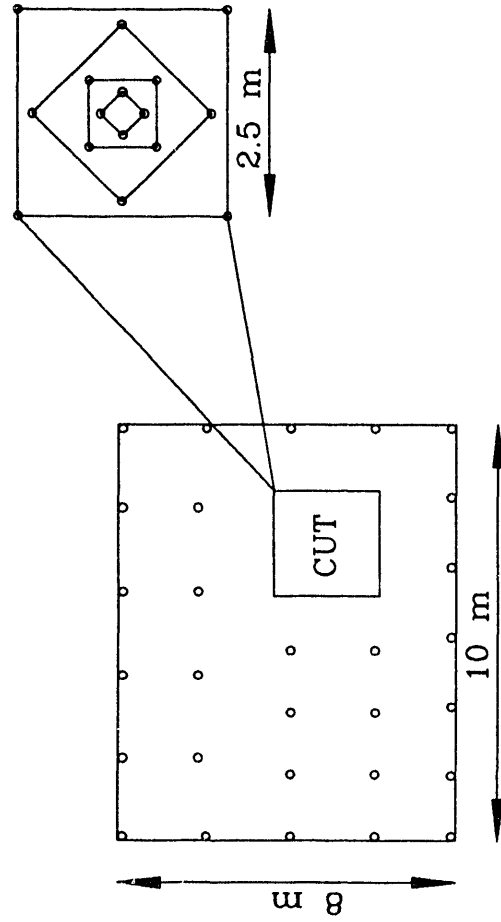

- Hole Diameter : 57 mm
- Hole Length : 5.3 m
- Advance per round : 5 m
- Total number of holes : 45
- Stemming : 0.57 m
- Specific Charge : 1.22 kg/m³

Figure B1. Blasting Layout for Mains and Submains

BLASTING LAYOUT HEADING

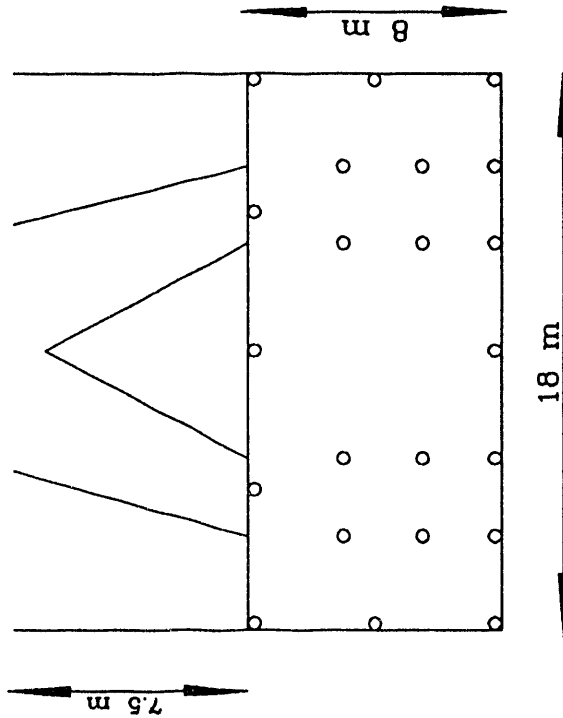

Hole length : 7 to 7.5 m
Specific Charge : 1.4 kg/m³
Advance : 7 m
Type of cut : V-cut
Stemming : 1.1 m
Hole diameter : 114 mm
Total number of holes : 22

Figure B2. Blasting Layout for the Heading

BLAST LAYOUT BENCHING

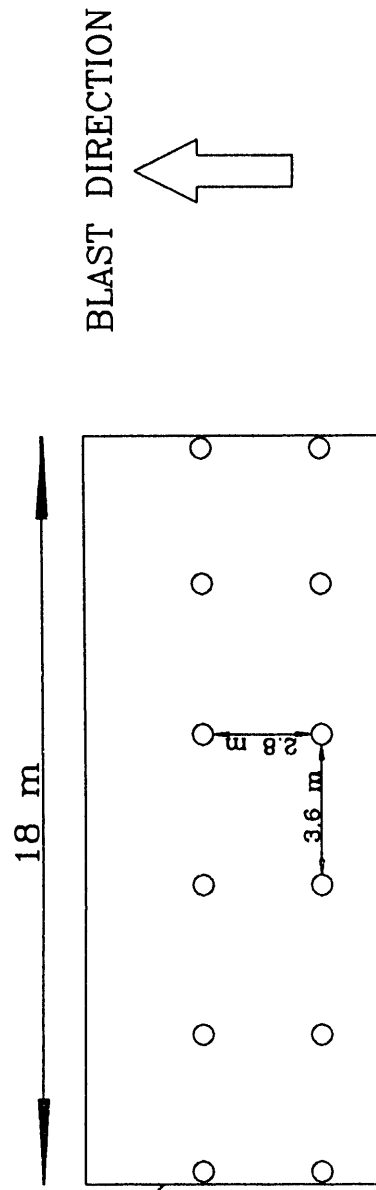

Hole Diameter : 114 mm

Burden : 2.8 m

Spacing : 3.6 m

Stemming : 2 m

Hole Length : 10 m

Specific Charge : 0.7 kg/m³

Figure B3. Blasting Layout for the Benching

PREPRODUCTION COST ESTIMATES FOR ROOM AND PILLAR

Shafts

The updated Scott-Ortech Cottonwood Wash Mine Feasibility Study (1982) has been used to estimate shaft sinking and shaft construction times. All costs have been adjusted to 1990 dollars using an average inflation rate of 2 percent.

Production Shaft:

The production shaft is a 9-m-diameter concrete-lined shaft. The costs include two single-drum hoists, four 60-ton skips, headframe foundation, head frame, skip-loading pocket, and hoist house.

| | |
|----------------------------|--------------|
| Estimated completion time: | 20 months |
| Total equipment cost: | \$14,750,000 |
| Sinking cost: | \$13,040,300 |

Service Shaft:

The service shaft is a 9-m-diameter concrete-lined shaft. The costs include one single-drum hoist, cage, head-frame, head frame foundation, and shaft station.

| | |
|----------------------------|--------------|
| Estimated completion time: | 25 months |
| Total equipment cost: | \$5,000,000 |
| Sinking cost: | \$11,787,000 |

Ventilation Shafts:

The ventilation shafts are 9 m in diameter. The sinking cost includes a ventilation station.

| | |
|--------------------------------------|--------------|
| Estimated completion time (exhaust): | 10 months |
| Estimated completion time (intake): | 10 months |
| Sinking cost: | \$11,495,000 |

Transportation Drifts Developed by the Contractor

One thousand meters of the mains (four entries) is developed by a contractor operating two shifts per day. The drift development is assumed done by drilling and blasting. The drifts are 10 m wide and 8 m high. The total cost for the drift development and the completion times has been estimated using Bureau of Mines Cost Estimating System Handbook (1987). The cost includes labor cost, supply cost, and equipment operating cost. The drift cycle includes drilling, loading, blasting, venting, mucking, scaling, rockbolting, lunch, and travel. Costs have been adjusted to 1990 dollars using an average inflation rate of 2 percent.

| | |
|------------------------|-------------|
| Drift length | 4 x 250 m |
| Tons of rock excavated | 176,000 ton |
| Advance rate | 10 m/day |
| Completion time | 200 shifts |
| Total cost | \$1,680,000 |

Main and Submain Preproduction

A total of 3,725,600 tons or 21,170 m of mains, submains, and access to the mining panels is developed as preproduction. The estimated completion time is 32 months using a production rate of 5,280 tpd (six rounds). The total cost includes drilling, blasting, rockbolting, loading, and hauling.

| | |
|------------------|----------------|
| Tons Excavated: | 3,725,600 |
| Completion time: | 32 months |
| Cost: | |
| 1. Drilling | \$1,247,300 |
| 2. Blasting | 1,885,200 |
| 3. Rockbolting | 1,763,600 |
| 4. Loading | 271,700 |
| 5. Hauling | <u>350,200</u> |
| Total Cost | \$5,518,000 |

Development of the First Mining Section

The first mining section is developed by the mine's own personnel operating two shifts/day, 22 day/month. The estimated completion time is 20 months. The cost includes drilling, blasting, rockbolting, loading, and hauling.

| | |
|-------------------|-----------------------|
| Tons excavated: | 4,809,000 |
| Production rate: | 11,090 tpd (5 rounds) |
| Completion time: | 20 months |
| 1. Drilling | \$357,800 |
| 2. Blasting | 1,670,000 |
| 3. Rockbolting | 1,653,900 |
| 4. Loading (988B) | 350,700 |
| 5. Hauling | <u>452,100</u> |
| Total Cost | \$4,484,500 |

Development of the Second, Third, and Fourth Mining Sections

The development of the second, third, and fourth mining sections takes place during the last fourteen months of preproduction. It is assumed that full development production (34,000 tpd) is achieved during these months and that the mine operates three shifts per day. One rotary twin-boom drill jumbo and two roof bolters have to be purchased to reach full development production. Also, labor cost is added during these last months of preproduction because four shift crews are used (each crew works 42 hr/week). The following types of personnel are needed:

supervisor (1), production engineers (4), foremen (4), surveyors (4), truck drivers (40), LHD operators (24), roof bolters (60), drill jumbo operator (4), rotary-drill jumbo operator (8), blasting team (12), crushing station operation (4), electricians (12), mechanics (40), machinist hoist (8), hoist operators (4), and scalers (12).

| | |
|--|--------------|
| Additional Equipment Cost (Year 6 of preproduction): | \$1,484,000 |
| Labor Cost (Year 6 of preproduction): | \$10,382,500 |
| Labor Cost (Year 7 of preproduction): | \$1,730,000 |
| Tons Excavated: | 14,427,000 |
| Completion Time: | 14 months |
| Production Rate: | 34,200 tpd |

| | |
|---|----------------|
| Cost for Developing Sections 2, 3, and 4: | |
| 1. Drilling, blasting, loading, and hauling | \$13,453,500 |
| 2. Crushing | <u>343,400</u> |
| Total Cost | \$13,796,600 |

Ancillary Facilities

The cost for the ancillary facilities has been estimated using Cameron Engineers Report (1977). Costs are adjusted to 1990 dollars using an average inflation rate of 2 percent.

| | |
|---|---------------|
| Cost (1977): | |
| 1. Maintenance and supply shop | \$ 130,000 |
| 2. Lunchroom, lamproom, and sanitary facility | 2,000,000 |
| 3. Explosive magazines (2) | <u>60,000</u> |
| Total Cost (1977) | \$2,190,000 |
| Total Cost (1990) | \$2,833,000 |

MISCELLANEOUS OPERATING AND CAPITAL COSTS FOR ROOM AND PILLAR

Hoisting

The following assumptions have been made for the hoisting system:

| | |
|---|----------------------|
| Acceleration stop to creep speed | 0.6 m/s ² |
| Acceleration creep speed to full speed | 1.0 m/s ² |
| Retardation full speed to approach speed | 1.0 m/s ² |
| Retardation approach speed to creep speed | 1.0 m/s ² |
| Retardation creep speed to stop | 0.6 m/s ² |
| Maximum full speed | 13 m/s |
| Creep speed | 0.6 m/s |
| Approach speed | 3 m/s |
| Hoisting distance | 570 m |

Table B1. Production Hoist Duty Schedule for Room and Pillar

| | Distance (m) | Time (s) |
|-------------------------------|-----------------|-------------|
| Acceleration: stop to creep | 0.6 | 1.0 |
| Run at creep speed | 3.0 | 5.0 |
| Acceleration to full speed | 84.3 | 12.4 |
| Run at full speed | 385.2 | 29.6 |
| Retardation to approach speed | 80.0 | 10.0 |
| Run at approach speed | 12.0 | 4.0 |
| Retardation to creep speed | 4.3 | 2.4 |
| Run at creep speed | 3.0 | 5.0 |
| Retardation creep to stop | 0.6 | 1.0 |
| Rest (load/dump) | --- | <u>30.0</u> |
| Total | <u>570</u> | <u>100</u> |

The production rate for the hoists (2) is based on 22 hr/day for hoisting of oil shale. Two hours per day are allowed for hoisting personnel and material. The estimated power requirement for the two hoists is 13,400 kW. It is assumed that the hoists are operating 24 hr/day for full production and 5 hr/day during preproduction. The operating cost is calculated using a power cost of \$0.05 per kW•hr. Maintenance cost is estimated at 10 percent of the power cost.

Operating Cost (production):

| | |
|---------------------|--------------|
| 1. Power Cost | \$16,100 |
| 2. Maintenance Cost | <u>1,600</u> |
| Total Cost per Day | \$17,700 |

Skip size: 60 ton
 Maximum production rate: 95,000 tpd
 Cost of hoisting 75000 tpd: 14,000/day

Operating Cost (preproduction):

| | |
|---------------------|------------|
| 1. Power Cost | \$3,250 |
| 2. Maintenance Cost | <u>325</u> |
| Total Cost per Day | \$3,575 |

Maximum production rate: 21,600 ton
 Cost of hoisting 11,600 tpd: \$1,920 per day
 Cost of hoisting 34,200 tpd: \$6,372 per day

Ventilation

The ventilation cost (operating and capital) has been estimated using USBM CEH (1987). The estimated ventilation requirement was based on the following assumptions:

1. 2.83 m³/min per diesel hp
2. 0.3 m/s minimum airway velocity
3. 6000 m³/s for shop and shaft pillar areas
4. 10 percent for leaks and losses

1. Total hp:

| | |
|--------------------------------------|---------------|
| Service trucks(3) | 246 |
| High-Capacity ANFO loading truck (2) | 164 |
| ANFO loading truck (2) | 164 |
| Water truck (3) | 246 |
| Lube and fuel truck (3) | 246 |
| Scissors lift truck (4) | 328 |
| Manning transportation vehicle (3) | 246 |
| Scaler (3) | 246 |
| Loader 992C (3) | 2,170 |
| Loader 988B (5) | 1,875 |
| Trucks (24) | <u>15,640</u> |
| Total hp | 21,571 |

Ventilation: 61,000 m³/min

2. Minimum airway velocity (0.3 m/s)
 - Heading: 12 faces (144 m²) 31,100 m³/min
 - Mains and submains: 1 face (80 m²) 1,400 m³/min
 - Benching: 4 faces (324 m²) 23,300 m³/min
4. Shop and shaft pillar area 6,000 m³/min
5. Leaks and losses (10 percent) 12,200 m³/min

The estimated total requirement is 135,000 m³/min. For estimating the operating cost, the mine head (Ht) has to be estimated. Ht was estimated at 6.44 kPa.

| | |
|-------------------------|-------------|
| Operating Cost per Day: | \$23,200 |
| Capital Cost: | \$6,829,400 |

The capital cost and the equipment operating part of the operating cost were adjusted to 1990 dollars using an average inflation rate of 2 percent. The preproduction cost of ventilation was estimated using a ventilation requirement of 13,500 m³/min and a mine head of 1000 Pa. The cost was estimated at \$363 per day.

Compressed Air

The estimated compressed air requirement is 890 m³/min. Capital cost and operating cost were estimated using USBM CEH (1987). The capital cost includes construction labor, construction supply cost, and purchased equipment cost. The operating cost includes supplies and equipment operating cost. Costs have been adjusted to 1990 dollars using an average inflation rate of 2 percent.

Table B2. Air Requirement for Room and Pillar

| Equipment | Air Requirement (m ³ /min) |
|-----------------------------|---------------------------------------|
| ICM Drills (10) | 360 |
| Drill Jumbo (rotary) | 12 |
| Drill Jumbo (percussion) | 12 |
| Air Motors (maximum 500 hp) | 420 |
| Drainage Pump | 6 |
| Leaks and Losses | <u>81</u> |
| Total | 891 |

Capital Cost: \$1,176,500

Operating Cost: \$2,900/day

Water Supply and Drainage

The water supply cost (operating and capital) has been estimated assuming a demand of 2,000 m³/day. The drainage cost was estimated assuming a pumping rate of 10,000 m³/day. USBM CEH (1987) was used for estimating the costs. Costs were adjusted to 1990 dollars using an average inflation rate of 2 percent. Costs include supplies and equipment operating costs.

Operating Cost:

| | |
|----------|-----------|
| Supply | \$108/day |
| Drainage | 1,485/day |

Capital Cost:

| | |
|----------|-----------|
| Supply | \$304,000 |
| Drainage | 667,500 |

Electrical Capital Cost

The electrical capital cost was estimated using USBM CEH (1987). The maximum demand for the mine was estimated at 20,000 kW. The load factors used were found in the updated Scott-Ortech's Cottonwood Wash Mine Feasibility Study (Synfuels Engineering, 1982). The cost has been adjusted to 1990 dollars using an average inflation rate of 2 percent. The capital cost is estimated at \$1,239,000.

Table B3. Electrical Power Requirement for Room and Pillar

| Equipment | Unit kW | Load Factor | Total kW |
|------------------------------|---------|-------------|--------------|
| Production Hoists (2) | 6,700 | 0.8 | 10,700 |
| Service Hoist (1) | 485 | 0.8 | 388 |
| Drill Jumbo (percussion) (2) | 60 | 0.6 | 72 |
| ITH Drills (10) | 60 | 0.6 | 360 |
| Rotary Drill Jumbo (2) | 60 | 0.6 | 72 |
| Crushing Station | 620 | 1.0 | 620 |
| Roof Bolters (14) | 30 | 0.7 | 294 |
| Compressor (4) | 224 | 1.0 | 896 |
| Pumps | 373 | 1.0 | 373 |
| Workshop | 110 | 0.7 | 77 |
| Lighting | 700 | 1.0 | 700 |
| Misc., losses (30 percent) | | | <u>4,366</u> |
| TOTAL | | | ~20,000 |

Fuel Consumption

The use factors are from Scott-Ortech Cottonwood Wash Mine Feasibility Study. The fuel price was estimated at \$1.0/gallon, which gives us a daily fuel cost of \$680. During the preproduction, the daily fuel cost was estimated at \$243.

Table B4. Fuel Requirement for Room and Pillar

| Diesel Equipment | gal/hr | Use Factor | Total gal/day |
|--------------------------------|--------|------------|---------------|
| High-Capacity ANFO Loaders (2) | 3.0 | 0.6 | 86.4 |
| Service Trucks (3) | 3.0 | 0.5 | 108.0 |
| Water Truck (3) | 3.0 | 0.4 | 86.4 |
| ANFO Loading Truck (2) | 3.0 | 0.2 | 28.8 |
| Lube and Fuel Truck (3) | 3.0 | 0.3 | 64.8 |
| Scissors Lift Truck (4) | 3.0 | 0.3 | 86.4 |
| Manning Trucks (3) | 3.0 | 0.1 | 21.6 |
| Scaler Trucks (3) | 3.5 | 0.5 | 126.0 |
| Tramming, etc. | | | 72.0 |
| TOTAL | | | 680.0 |

Crushing Operating and Capital

The blasted ore is assumed crushed to an average size of 10 to 20 centimeters before it is hoisted to the surface. The costs for construction of the crushing station (labor) and purchase of supplies are included in the capital cost estimated using USBM CEH (1987). The operating cost for the crushing of oil shale consists of power cost and maintenance cost. The maintenance cost is estimated at 120 percent of the power cost. The power requirement for crushing the material from a size where 80 percent of the mine-run material passes a sieve size of 1 m in diameter down to a size where 80 percent of the material passes 0.20 m in diameter has been estimated using Bond's theory. All cost have been adjusted to 1990 dollars using an average inflation rate of 2 percent. The estimated completion time is 24 months.

Capital Cost for Construction of Crushing Station:

| | |
|-----------------------|----------------|
| 1. Construction labor | \$362,600 |
| 2. Supplies | <u>336,600</u> |
| Total capital cost | \$699,200 |

Operating Cost per Day (75,000 ton crushed):

| | |
|--------------------------------|------------|
| 1. Power (0.216 kW•hr/ton) | \$810 |
| 2. Maintenance | <u>972</u> |
| Operating cost per day | \$1,782 |
| Operating cost per ton crushed | \$0.0238 |

Surface Disposal of Spent Shale

An operating cost for surface disposal of spent shale was added. It was assumed that the same amount (28,000 m³ per day) of spent shale was deposited at the surface in the room and pillar design as backfilled underground for the large-hole stoping case. The cost was estimated using USBM CEH (1987, p. 189). It was assumed that scrapers and dozers will be used for the surface disposal of spent shale. The cost includes equipment operating cost and labor cost. The cost has been adjusted to 1990 dollars using an average inflation rate of 2 percent.

| | |
|-----------------------------------|---------------------------------|
| Ton spent shale disposed per day: | 50,400 (28,000 m ³) |
| Cost per day: | \$22,000 |

DEPRECIATION SCHEDULE FOR ROOM AND PILLAR

Table B5. Depreciation Schedule for Room and Pillar

| Depreciation Period (yr) | Type of Equipment | Total Investment (\$1000) | Annual Depreciation Cost (\$1000) |
|-----------------------------|---|---------------------------------|---|
| 10 | Trucks (34) | 13,090 | 1,309 |
| 10 | LHD 992C (3) | 1,230 | 123 |
| 10 | LHD 988B (5) | 1,450 | 145 |
| 10 | Drill Jumbo (rotary) (2) | 896 | 90 |
| 10 | Drill Jumbo (percussion) (2) | 780 | 78 |
| 10 | ANFO Trucks (2) | 800 | 80 |
| 10 | ITH Drills (10) | 1,520 | 152 |
| 10 | Scaler (3) | 600 | 60 |
| 10 | Service Trucks (3) | 186 | 19 |
| 10 | Roof Bolters (14) | 7,252 | 725 |
| 10 | Anfo Loader (2) | 163 | 16 |
| 10 | Water Trucks (3) | 183 | 18 |
| 10 | Lube & Fuel Trucks (3) | 245 | 25 |
| 10 | Scissors Lift Trucks (4) | 282 | 28 |
| 10 | Manning Trucks (3) | 212 | 21 |
| 10 | Ambulance (2) | 160 | 16 |
| 10 | Equip. Shop | 1,300 | 130 |
| 20 | Crushing Station | 1,891 | 95 |
| 30 | Preproduction Development (including interest) | 183,181 | <u>6,106</u> |
| | TOTAL | | 9,236 |

Table B6. Average Annual Interest Cost for Room and Pillar

| Depreciation Period (yr) | Total Investment (\$1000) | Yearly Interest Cost (\$1000) |
|-----------------------------|------------------------------|----------------------------------|
| 10 | 30,349 | 1,502 |
| 20 | 1,891 | 89 |
| 30 | 183,181 | 8,518 |
| Working Capital | 19,474 | <u>1,753</u> |
| TOTAL | | 11,862 |

TABLE OF CONTENTS

| | <u>Page</u> |
|---|-------------|
| SUMMARY..... | ii |
| LIST OF TABLES..... | vi |
| LIST OF FIGURES..... | vii |
| NOMENCLATURE..... | ix |
| INTRODUCTION..... | 1 |
| Background..... | 1 |
| True In Situ Retorting..... | 1 |
| Modified In Situ Retorting..... | 2 |
| Conventional Underground Mining Techniques..... | 2 |
| Statement of the Problem..... | 3 |
| Scope of Work..... | 4 |
| FRAGMENTATION IN BUFFER BLASTING..... | 8 |
| Introduction..... | 8 |
| Fragmentation Process..... | 9 |
| Breakage Related to Strain Waves..... | 10 |
| Breakage Related to Gas Pressure..... | 12 |
| Fragmentation Process in Buffer Blasting..... | 12 |
| Parameters Affecting Fragmentation..... | 16 |
| Swell..... | 17 |
| Timing..... | 19 |
| Blast Layout..... | 22 |
| Fragmentation Prediction by Empirical Formulae..... | 22 |
| Size distribution..... | 23 |
| Empirical Formulae for Fragmentation Size..... | 24 |
| Kuzetsov's Formula..... | 24 |
| SveDeFo-Nitro Nobel Formulae..... | 25 |
| Kuz-Ram Model..... | 26 |
| Buffer Compaction and Draw Control..... | 29 |
| Summary of Past Buffer-Blasting Studies..... | 37 |
| Model-Scale Buffer-Blasting Experiments..... | 38 |
| Conclusions of Buffer-Blasting Experiments..... | 38 |
| Design of Full-Scale Buffer-Blasting Experiments..... | 40 |
| TWO METHODS FOR MINING OIL SHALE..... | 44 |
| Large-Hole Stopping Method Using Buffer Blasting..... | 45 |
| Overall Mine Plan..... | 45 |
| Overcut Level..... | 46 |
| Loading Level/Undercut..... | 46 |
| Conventional Room and Pillar Method..... | 49 |
| Overall Mine Plan..... | 49 |

TABLE OF CONTENTS (Continued)

| | |
|--|-----------|
| Preproduction Development..... | 51 |
| Shaft Sinking..... | 51 |
| Overcut Preproduction for Large-Hole Stoping..... | 51 |
| Undercut Preproduction for Large-Hole Stoping..... | 54 |
| Mains and Panel Preproduction for Room and Pillar..... | 54 |
| Ancillary Facilities..... | 55 |
| Labor Requirements..... | 55 |
| Equipment Requirements..... | 55 |
| Ventilation, Air, and Water Consumption..... | 55 |
| Installation of Air, Water, and Electricity Systems..... | 55 |
| Crushing Station..... | 55 |
| Time Table..... | 57 |
| Production..... | 57 |
| Development for Large-Hole Stoping..... | 59 |
| Production Drilling and Blasting for Large-Hole Stoping..... | 59 |
| Loading and Hauling for Large-Hole Stoping..... | 59 |
| Development for Room and Pillar..... | 63 |
| Production Drilling and Blasting for Room and Pillar..... | 63 |
| Loading and Hauling for Room Pillar..... | 64 |
| Labor Requirements..... | 64 |
| Equipment Requirements..... | 64 |
| Ventilation..... | 64 |
| Water and Compressed Air..... | 67 |
| Mining Costs..... | 67 |
| Preproduction Cost..... | 67 |
| Capital Investment Cost..... | 67 |
| Operating Cost..... | 67 |
| | |
| COMPARISON BETWEEN LARGE-HOLE STOPING USING BUFFER BLASTING AND CONVENTIONAL ROOM AND PILLAR METHODS..... | 73 |
| Mining Costs..... | 73 |
| Technical Characteristics..... | 74 |
| Development Time and Tonnage..... | 75 |
| Specific Development..... | 75 |
| Productivity..... | 75 |
| Mining Selectivity..... | 76 |
| Resource Recovery..... | 76 |
| Health and Safety Rank..... | 76 |
| Production Increase..... | 76 |
| Automation Possibilities..... | 77 |
| | |
| CONCLUSIONS AND RECOMMENDATIONS..... | 77 |
| Conclusions..... | 77 |
| Recommendations..... | 78 |
| | |
| ACKNOWLEDGEMENTS..... | 79 |
| | |
| DISCLAIMER..... | 79 |

TABLE OF CONTENTS (Continued)

| | |
|---|------------|
| REFERENCES..... | 80 |
| APPENDIX A. Supplementary Material for the Large-Hole Stopping Method... | A-1 |
| APPENDIX B. Supplementary Material for Room and Pillar Mining..... | B-1 |

LIST OF TABLES

| <u>Table</u> | <u>Page</u> |
|--|-------------|
| 1. Determination of Rock Factor A..... | 28 |
| 2. Percentage of Rock Drawn Out Calculated for an Optimum Swell Factor of 1.4..... | 32 |
| 3. Summary of Equations of Displacement..... | 34 |
| 4. Explosive Parameters..... | 41 |
| 5. Mine Design..... | 44 |
| 6. Shaft Complex..... | 45 |
| 7. Preproduction Labor List..... | 56 |
| 8. Preproduction Equipment List..... | 57 |
| 9. Belt Conveyors..... | 63 |
| 10. Underground Labor List..... | 65 |
| 11. Equipment List..... | 66 |
| 12. Preproduction Cost Per Year for Large-Hole Stopping..... | 68 |
| 13. Preproduction Cost Per Year for Room and Pillar..... | 69 |
| 14. Total Preproduction Cost..... | 70 |
| 15. Capital Investment Cost..... | 70 |
| 16. Operating Cost for Large-Hole Stopping..... | 71 |
| 17. Operating Cost for Room and Pillar..... | 72 |
| 18. Economic Comparison..... | 73 |
| 19. Technical Comparison..... | 74 |
| 20. Advantages and Disadvantages of the Two Mining Methods..... | 75 |
| 21. Health and Safety Ranking..... | 76 |

LIST OF FIGURES

| <u>Figure</u> | <u>Page</u> |
|--|-------------|
| 1. Rio Blanco's Oil Shale Project..... | 3 |
| 2. Large-Hole Stoping using Buffer Blasting..... | 5 |
| 3. Average Thicknesses and Grades for the Colony Operation..... | 6 |
| 4. Belt Bender Snake..... | 7 |
| 5. Sublevel Caving..... | 10 |
| 6. Rill Mining..... | 11 |
| 7. Reflecting Tensile Wave, Normal to the Radial Crack..... | 12 |
| 8. Detonating Charges Cause Waves to Reflect at the Interface Between the Buffer and the Solid Rock..... | 13 |
| 9. Wave Velocity In the Buffer as a Function of the Swell Factor..... | 15 |
| 10. Reflecting Tensile Wave as a Function of the Swell Factor..... | 15 |
| 11. Mean Fragmentation Diameter (k_{50}) Versus Spacing-to-Burden Ratio for SF = 1.3, 1.4, and 1.6..... | 18 |
| 12. Yield of Blasted Material that is Over Size (>40 mm) Versus Spacing-to-Burden Ratio for SF = 1.3, 1.4, and 1.6..... | 18 |
| 13. Experiment Setup..... | 20 |
| 14. Side View of Experiment Setup..... | 20 |
| 15. Shapes of the Void Volumes..... | 21 |
| 16. Function $f(h/l_d)$ | 27 |
| 17. Fragmentation Gradient in the Rosin-Rammler Distribution..... | 27 |
| 18. Side View Showing the Stoping Bench, the Zone of Compaction, and the Loose-Packed Zone..... | 30 |
| 19. Displacement of the Buffer Versus the Distance Away from the Bench..... | 30 |

| | | |
|-----|--|----|
| 20. | Swell Factor of the Buffer Versus the Distance Away from the Bench..... | 31 |
| 21. | Loose-Packed Zone Versus the Thickness of the Blasted Layer..... | 31 |
| 22. | Displacement at the Blast Front Versus Thickness of the Blasted Layer..... | 33 |
| 23. | Side View Showing the Stoping Bench, the Distance x , and the Thickness of the Blasted Layer, 1..... | 33 |
| 24. | S_0 , Swell, and Free Space Available Versus Thickness, 1, of the Blasted Layer..... | 36 |
| 25. | Swell Available For Each 3-m Row Being Blasted..... | 36 |
| 26. | Side View Showing Bench and Buffer..... | 41 |
| 27. | Experiments No. 1 and No. 2..... | 42 |
| 28. | Experiments No. 3 and No. 4..... | 43 |
| 29. | Plan View Overcut Level..... | 47 |
| 30. | Cross Sections of Two Stopes Sharing the Same Loading Drift..... | 48 |
| 31. | Plan View Undercut Level..... | 50 |
| 32. | Isometric View of the Mining Section..... | 52 |
| 33. | Layout of the Panels..... | 53 |
| 34. | Time Table for Large-Hole Stoping Preproduction | 58 |
| 35. | Time Table for Room and Pillar Preproduction..... | 58 |
| 36. | Stope and Transportation Drift Development (Overcut)..... | 60 |
| 37. | Undercut Development..... | 61 |
| 38. | Stope Conveyors and Main Conveyors on the Undercut..... | 62 |

NOMENCLATURE

ANFO: An explosive material consisting of 94% Ammonium Nitrate and 6% Fuel Oil.

benching: An operation on a horizontal ledge from which holes are drilled vertically down into the material being blasted.

burden: The distance from the borehole and the nearest free face or the distance between boreholes measured perpendicular to the spacing.

CAT: Caterpillar Earth Movers.

dead pressing: The detonation propagating wave compressing the explosive until it can no longer detonate.

development: Work of driving openings to and in a proved ore body to prepare it for mining and transporting the ore.

double pass: A full-size section excavated in two steps, in this study, first with a heading and later with benching.

drill jumbo: Generic name for a mobile rig equipped with drilling machines.

feeder breaker: In this report, an underground mobile crusher.

heading: A smaller excavation driven in advance of the fullface section. A heading may be driven at the top or the bottom of the fullface section; in this report, at the top.

ITH drill: Generic name for in-the-hole drills used in stoping and large underground ore bodies.

k₅₀: Mean fragmentation diameter. Particle size is 50% by weight of the material passes.

k_s: Maximum particle size of the distribution. The smallest particle size is 100% by weight of the material passes.

LHD: Front-end loading vehicles especially designed to Load-Haul-Dump in underground mines.

mean fragmentation diameter: k₅₀.

PETN: An explosive material, pentaerythritol tetranitrate.

preproduction development: Mining operations to facilitate mining after the deposit has been explored. Work may include shaft sinking, sublevels between levels, chutes, raises, and other works.

roof bolter: Machine capable of drilling and installing rock bolts for roof support.

round: Planned pattern of drill holes fired in sequence in tunneling, shaft sinking, stoping, or benching.

slurry: An explosive material containing substantial portions of liquid, oxidizers, and fuel plus a thickener.

spacing: The distance between boreholes. In bench blasting, the distance is measured parallel to the free face and perpendicular to the burden

specific charge: The amount of explosive (by weight) used per unit volume of rock (bank).

specific development: The amount of development (ton) as a percentage of total production (ton). For example, a mine with a daily production of 2,000 ton and a specific development of 25% develops 500 ton per day.

stope: An excavation from which ore has been extracted. The term does not include the ore removed in sinking shafts and in driving levels, drifts, or other development openings.

stoppings: A brattice or, more commonly, a masonry or brick wall built across old headings, chutes, air ways, etc. to confine the ventilating current to certain passages. Also, to lock up gas in old workings.

swell: The percentage (volume) that material (e.g., rock, soil) swells from bank volume to loose volume.

weight strength: The energy of an explosive material per unit weight. Commonly expressed as a percentage of the energy per unit of weight of a specified explosive standard.

INTRODUCTION

Background

Extraction of oil from oil shale has been tried on a large scale since the 1940s, but it was not economical. However, with increasing oil prices, increased demand, and the rising importance of energy self-sufficiency, recovery of oil from oil shale may be viable. For example, the United States consumption of crude oil in 1989 was 6.2 billion barrel, and the total reserve in 1988 was estimated at 66 billion barrels (DOE/EIA, 1990). World shale deposits richer than 25 gallons per short ton contain an estimated total of 910 billion barrels of oil, two thirds of which is found in the United States. The Green River Formation of Colorado, Utah, and Wyoming contains the largest concentration of potentially recoverable shale oil in the world (Exxon, 1982).

Oil shale deposits occur at different depths, thicknesses, and grades (Hustrulid et al., 1984). In Colorado, the richest deposits have a thickness of 600 meters with an overburden depth of up to 500 meters. These deep deposits can only be extracted using underground mining techniques. Different approaches are taken to extract the oil from the deep oil shale beds, including true in situ retorting, modified in situ retorting, and conventional underground mining techniques. Some of these approaches are conceptual, whereas others have been tried in laboratory settings or in field experiments.

True In Situ Retorting

In true in situ retorting, boreholes are drilled from the surface to access the oil shale formation. The boreholes are then used for fracturing the oil shale bed. Several techniques are used for creating fractures including explosives fracturing and hydraulic fracturing. The fractured oil shale formation is then retorted, and the oil is recovered from wells drilled to the bottom of the rubblelized zone.

For rubblelizing the formation, a swell/expansion volume has to be present. For shallow oil shale beds, the expansion volume is created by lifting the overburden. For deep beds, the borehole volume itself is used as expansion volume. In the latter case, the expansion volume is extremely small and not sufficient for rubblelizing the oil shale. Therefore, it is concluded that this method is not applicable to the deep oil shale beds of Colorado.

Geokinetics began true in situ retorting operations at Kamp Kerogen, Uintah County, Utah, in 1975 (Hustrulid et al., 1984). The oil shale bed of 9 m had an overburden thickness of 0 to 34 meters. A pattern of blast holes was drilled from the surface to the bottom of the formation and loaded with liquid explosives. The expansion volume was created by lifting the overburden when blasting. The fractured oil shale was then ignited, and the oil was recovered from a well drilled to the bottom of the fractured formation. Results from the Geokinetics operation indicated that oil recoveries of up to 50 percent were achieved for the shallow-bed operation.

Modified In Situ Retorting

In modified in situ retorting, a portion of the oil shale bed is mined out to provide space for rubblization. The rubblized oil shale is then retorted in situ, and the oil is recovered from a sump at the bottom of the retort. A small surface retort is also required for retorting of the mined out portion of the oil shale. It is desirable to create a rubblized mass with a uniform permeability that can easily be retorted by the hot gases. High permeability zones may cause channeling of the hot gases that can result in poor recoveries.

The modified in situ retorting approach has the advantage that thick seams of oil shale can be mined. However, relative extensive mining using conventional mining techniques has to take place to develop underground workings and expansion volumes for rubblization of the oil shale. Experience shows that about 20-40 percent of the retorted oil shale is mined using conventional underground mining techniques. This amount includes about 15-25% for swell (to provide expansion space for rubbling) and 10% for underground access. In combination with the relatively poor recoveries achieved to date (30 to 70 percent), this makes modified in situ retorting less interesting than conventional underground mining techniques. However, if recoveries of 70 to 80 percent are achieved, interest in modified in situ retorting are sure to increase.

Occidental Oil Shale Inc. and Rio Blanco Oil Shale are two companies with the most experience using modified in situ retorting. Rio Blanco operated a modified in situ retorting complex at the end of the 1970s (Figure 1) (Hustrulid et al., 1984). Large blastholes (230 to 250 mm in diameter) were drilled from the surface in a pattern with a hole spacing of about 5 meters for rubblizing of the retorts. An undercut was excavated at the bottom of the retort. The blastholes were loaded and shot as in vertical crater retreat, and the swell (15 to 40 percent) was loaded out from the undercut for surface retorting. Oil recoveries of up to 68 percent were achieved for the in situ retorting.

Occidental performed modified in situ retorting field experiments from 1972 to the beginning of the 1980s. Eight retorts were constructed, four of them in cooperation with the Department of Energy (Hustrulid et al., 1984). Oil recoveries from 30 to 60 percent were achieved from expansion volumes ranging from 20 to 35 percent.

Conventional Underground Mining Techniques

The third approach for recovery of oil from oil shale is conventional underground mining technique with surface retorting. This method may be the most economic alternative for the deep (about 500 meters overburden) oil shale beds of Colorado. A high recovery is achieved with surface retorting (up to 95 percent) in comparison with in situ retorting (around 50 percent). Large-scale room and pillar mining in the rich Mahogany zone has been performed since the 1940s by the U.S. Bureau of Mines, Unocal, Colony, Mobil, and Paraho. However, for the thick, deep deposits of Colorado, other underground mining methods should be investigated.

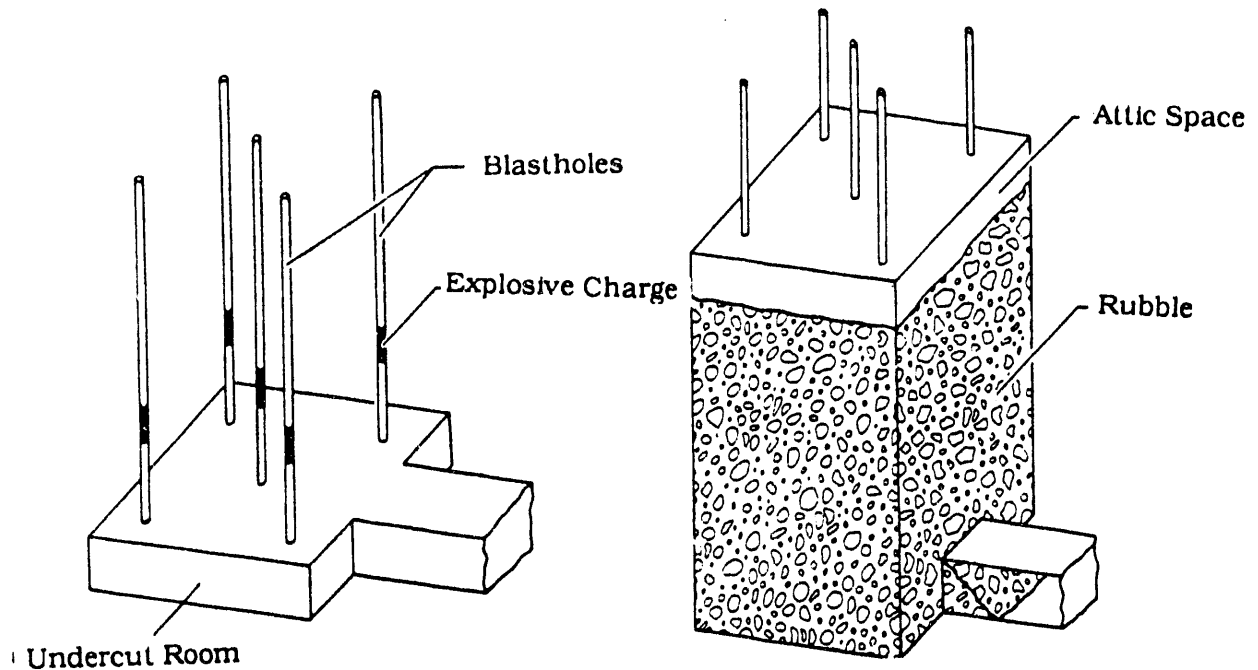

Figure 1. Rio Blanco's Oil Shale Project (Hustrulid et al., 1984)

The first commercial oil shale complex was operated by Unocal in Parachute Creek starting in 1981 (Hustrulid et al., 1984). Room and pillar mining in the rich Mahogany zone was performed using conventional rubber-tired loading and hauling (50 ton trucks and 12 cubic yard loaders), rotary drill jumbos, and automatic roof bolters. The rooms were 18 m high and 12 m wide. The extraction ratio was 75 percent, and the mine was scheduled for a production of 12,000 tons per day (tpd).

Statement of the Problem

Conventional underground mining with surface retorting is considered the most economical alternative for extracting oil from deep oil shale beds. Conventional room and pillar mining was tried by numerous companies, but it was not economical. A high production is required for a low operating cost per ton; however, relatively low production was achieved. Therefore, other underground large-scale mining methods should be investigated for the deep oil shale beds of Colorado.

The trend in mining today is toward larger-scale mining methods to meet production requirements. The advantages of large-scale mining methods include higher productivity and lower specific development. Also, the preproduction development will decrease since the development is not required to be as far ahead of the production as in smaller-scale mining methods. This will lower the interest cost associated with the investment cost for starting up a project.

There are limitations to the scale of the mining methods. Perhaps the most obvious one is the size and the geometry of the ore body. A large-scale mining method requires a relatively large ore body, preferably with an even geometry in order to minimize ore loss and dilution. Other limitations are rock mechanics and mining machinery. Rock mechanics considerations limit the height and size of open stopes. The mining machinery limits the hole length that can be drilled with reasonable accuracy, but the size of the available mining machinery keeps increasing. Machinery that has been used for years in open pit mines is being brought underground. For example, underground mobile crushers and rotary in-the-hole drills are used for drilling large, long parallel holes.

Mining in most mines is a cyclic operation of drilling, blasting, roof bolting, and mucking. However, a more continuous mining system with the unit operations relatively independent of each other is desirable. A continuous mining system decreases standby time and leads to higher equipment use and increased productivity.

A large-scale continuous mining method is applicable to mining oil shale in Colorado because the deposits usually are massive. Figure 2 shows a potential mining method, large-hole stoping, which uses buffer blasting. The overcut is located in the Mahogany zone and the undercut in the R6 zone (Figure 3). Mechanical miners are used for the development of the overcut and the undercut. Large-diameter, parallel holes are drilled and charged from the overcut. Continuous loaders extract oil shale from the undercut (Figure 2). Stopes are kept full of broken or spent shale to minimize rock mechanics problems. Buffer blasting, blasting toward the rubblized material, is performed. Belt conveyors are used for transporting the oil shale from the mining areas. A bendable snake conveyor is a novel concept for transporting material by conveyors around corners and in areas with limited space from behind a mechanical miner or a continuous loader (Figure 4). Such a conveyor is used in this potential mining method.

Scope of Work

This report describes a large-scale underground mining method, large-hole stoping, using some innovative fragmentation systems (buffer blasting, continuous loading/hauling, and mechanical miners for development). This study includes a literature review and an experimental study of one of the key design factors—buffer blasting. The purpose of the buffer-blasting experiments is to examine the swell that is necessary to achieve satisfactory fragmentation results. The study also includes a technical and economic evaluation of the new mining method compared with conventional room and pillar mining.

The purpose of this study is to examine innovative methods that exist today and may provide a more efficient mining system than that currently used. Note that this is a conceptual study, and that the mining for the two mine designs were compared using a daily production rate of 75,000 tons per day. This amount was chosen because it is the maximum amount possible for a rubber-tired room and pillar operation with only a one-shaft complex.

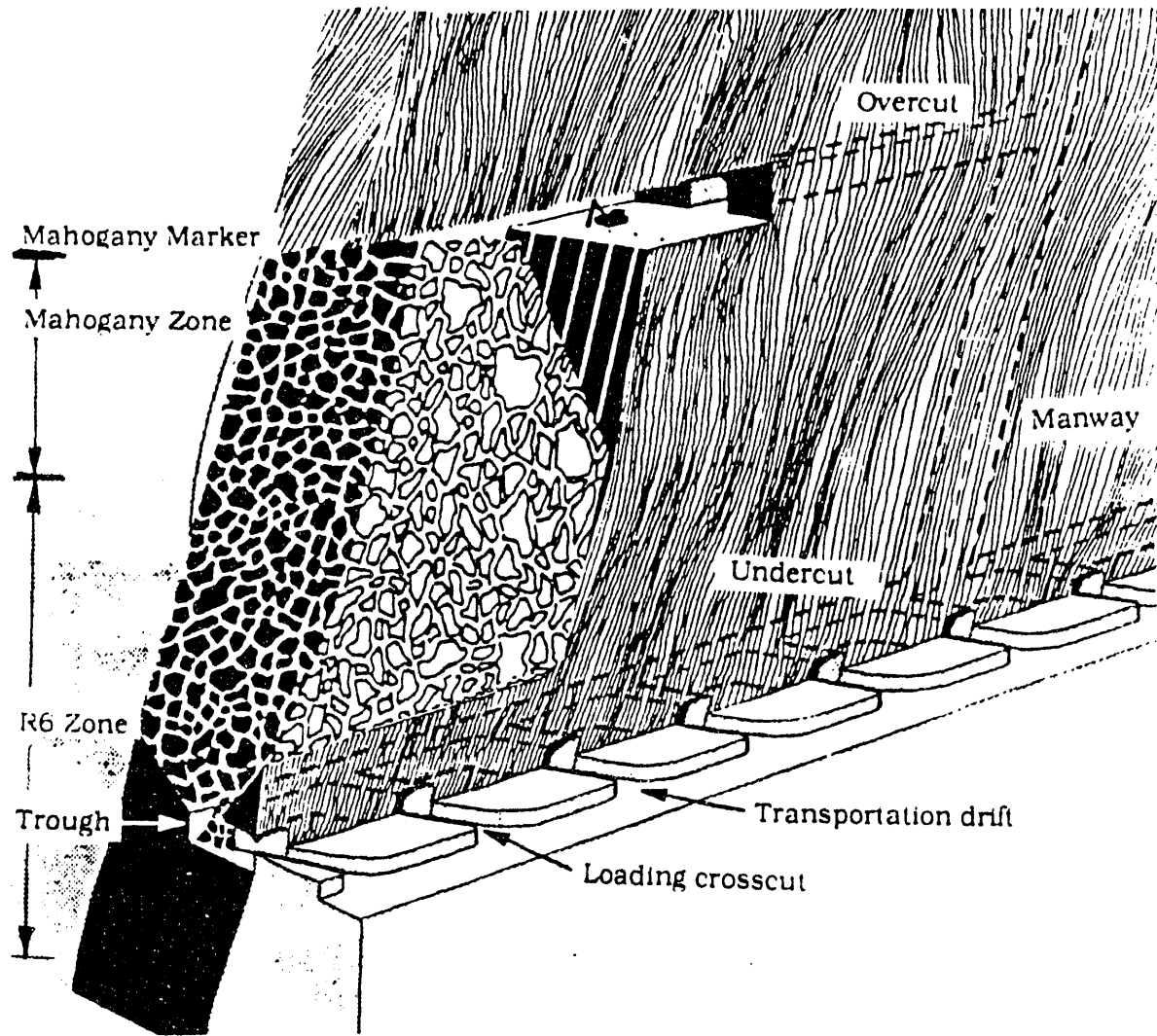
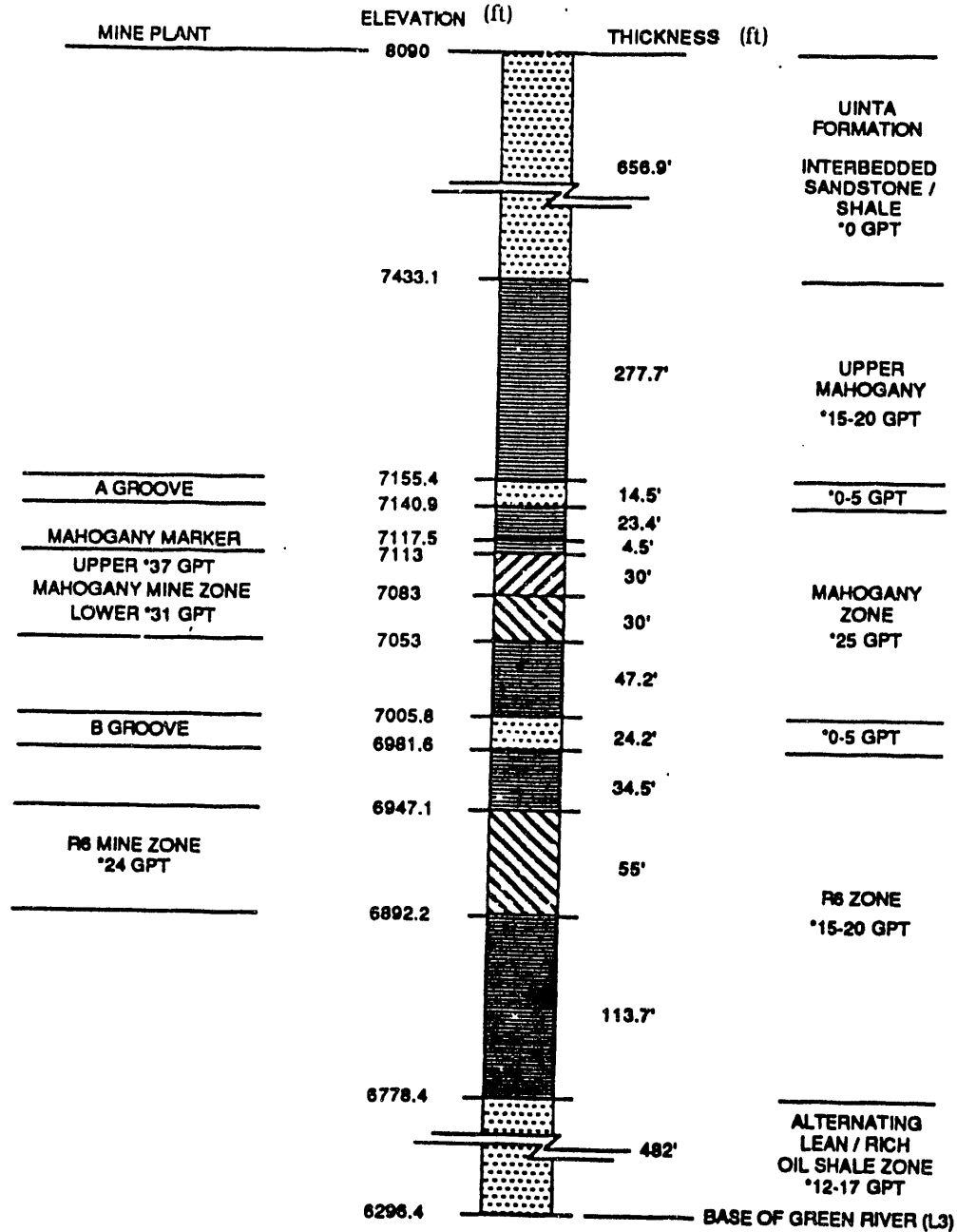

Figure 2. Large-Hole Stoping using Buffer Blasting (Hamrin, 1986)

EXXON COLONY SHALE OIL PROJECT



* APPROXIMATE AVERAGE GRADE

GENERALIZED LITHOLOGICAL COLUMN AT THE PLANT SITE

Figure 3. Average Thicknesses and Grades for the Colony Operation (Exxon, 1988)

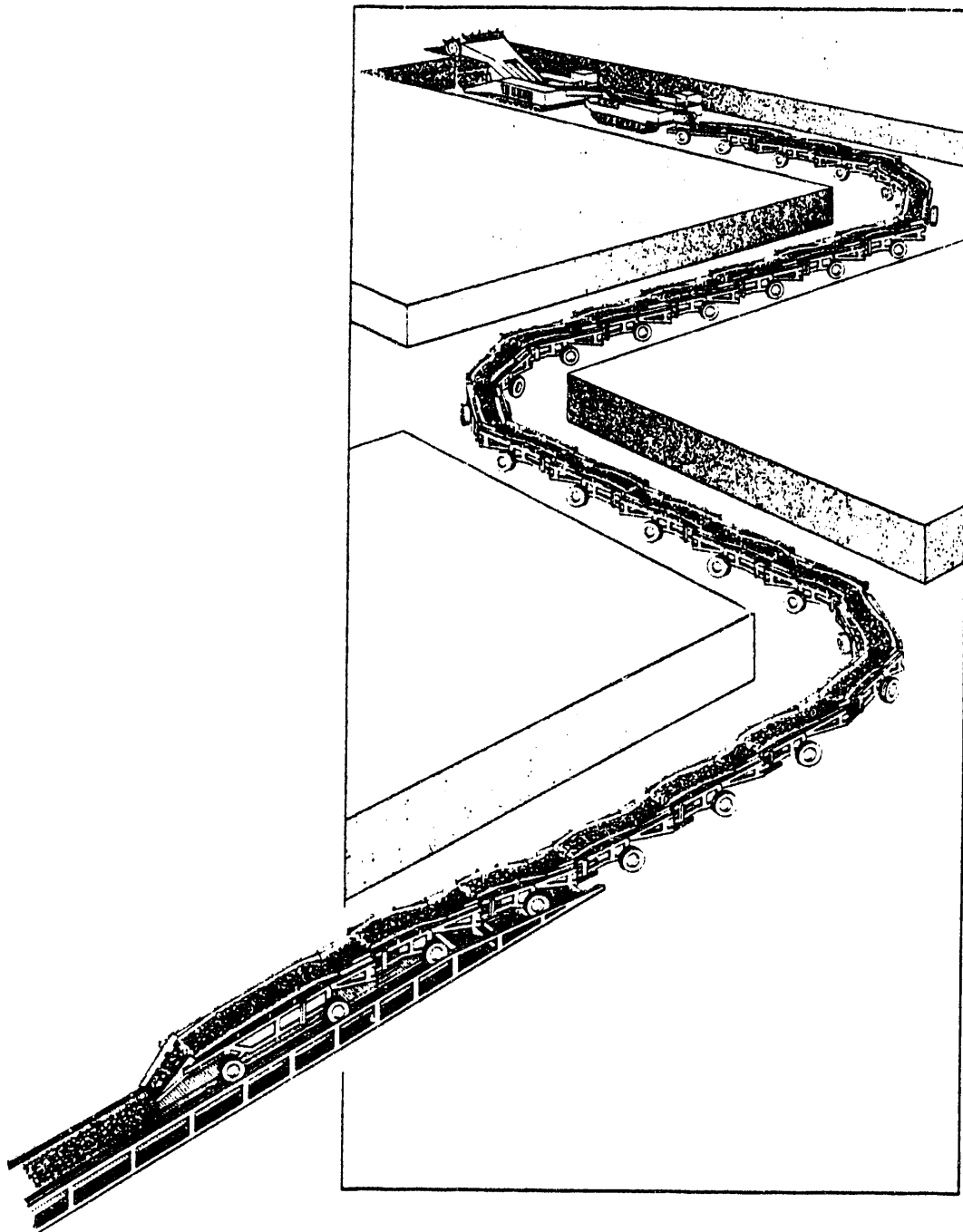

Figure 4. Belt Bender Snake (DME Enterprises Inc., 1989)

FRAGMENTATION IN BUFFER BLASTING

Introduction

Improved fragmentation is desirable in today's mining operations. This is done to cut explosive, drilling, crushing, and handling costs, but it also increases the productivity of the loading operation. Buffer blasting is defined as blasting toward a buffer of fragmented rock. Buffer blasting has been used underground in the Soviet Union as a technique for fragmentation improvement. Dubynin (1973) reports that this blasting technique (in combination with a large-scale mining method like large-hole stoping or sublevel stoping) led to improved fragmentation, minimization of ground-control problems (since the stopes were kept full of fragmented rock), and to a more efficient loading operation.

One of the most important parameters for the fragmentation in buffer blasting is the swell or expansion volume available in the buffer. Some model-scale experiments in the Soviet Union and in Sweden suggest that blasting toward a buffer with a limited swell gives better fragmentation than blasting toward a free face (Volchenko, 1977; Olsson, 1988). Other model-scale experiments indicate that the fragmentation size increases as the swell in the buffer decreases (Holmberg, 1981).

This part of this report is an experimental study of buffer blasting. There are two study objectives: (1) review the research conducted in the field of buffer blasting and (2) experimentally examine the swell required in the buffer for satisfactory fragmentation results. Model buffer blasting was conducted at the Colorado School of Mines experimental mine in Idaho Springs, Colorado.

Buffer blasting is blasting toward a buffer that consists of either fragmented rock, tailings, or any other fill. Buffer blasting is being practiced in several different mining methods today; although the purpose of buffer blasting is not always to improve fragmentation. Sometimes buffer blasting is used to extract ore (as in sublevel caving and rill mining). The degree of fragmentation obtained by the buffer-blasting technique is highly dependent on the swell available in the buffer.

Swell is defined as the volume of void space in the material, expressed as a percentage of the volume of solid material.

$$\text{swell } (\%) = 100 \left[\frac{V_{\text{void}}}{V_{\text{s}}} \right] \quad (1)$$

Where V_{void} = volume of voids in the material
 V_{s} = volume of solid material (voids excluded)

The swell factor (SF) for blasted material is defined as how much the blasted material has expanded from a solid state to a loose state. For example, a material of 1 m^3 of rock (loose) with a swell factor of 1.5 is the same as 0.67 m^3 of solid rock that has expanded 1.5 times to a volume of 1 m^3 .

$$SF = \frac{1 + \text{Swell } (\%) }{100} \quad (2)$$

$$SF = \frac{V_{\text{loose}}}{V_s} \quad (3)$$

Where V_{loose} = volume of the broken material, x cubic meters
 V_s = volume of solid material, x cubic meters

Accordingly, the swell factor of the free space is defined as how much the solid rock volume is permitted to expand from a solid state to a loose state. Normally, this value is greater than 1.5, which is a sufficient swell for rock during blasting.

In sublevel caving (Figure 5), slices of ore are blasted against a buffer of caved waste rock. In this mining method, the swell of the buffer closest to the slice being blasted is dependent on the height of the buffer, the fragment size-distribution of the caved waste rock, and the inclination of the slice that is being blasted (Rustan, 1990). However, the swell of the buffer closest to the slice being blasted is difficult to control.

Rill mining is a cut-and-fill mining method used in Sweden, Germany, and Canada (Rustan, 1990). In rill mining, a very compact fill is desirable because the fill is used for supporting the host rock (Figure 6) and not necessarily to improve fragmentation. The choice of filling material determines the swell that is available in the buffer. Several kinds of filling material are used in this method, including waste rock, cement-rock fill, and tailings.

Large-hole stoping and sublevel stoping methods with buffer blasting have been used in the Soviet Union. Model-scale experiments show optimum fragmentation while blasting toward a buffer with 40 percent swell (Volchenko, 1977). In production, this is obtained by loading out only a part of the volume after each blast (Figure 2).

Fragmentation Process

As an explosive is initiated, a high-pressure detonation wave propagates along the explosive column with a velocity of 2000 to 7000 meters per second. This shock wave has a duration of only a few microseconds. The gas pressure in the borehole drops drastically, but it is still high enough to exert a quasistatic load on the borehole walls (Kutter and Fairhurst, 1971). Both the dynamic loading (strain wave) and the quasistatic loading (gas pressure) play an important role in rock fragmentation.

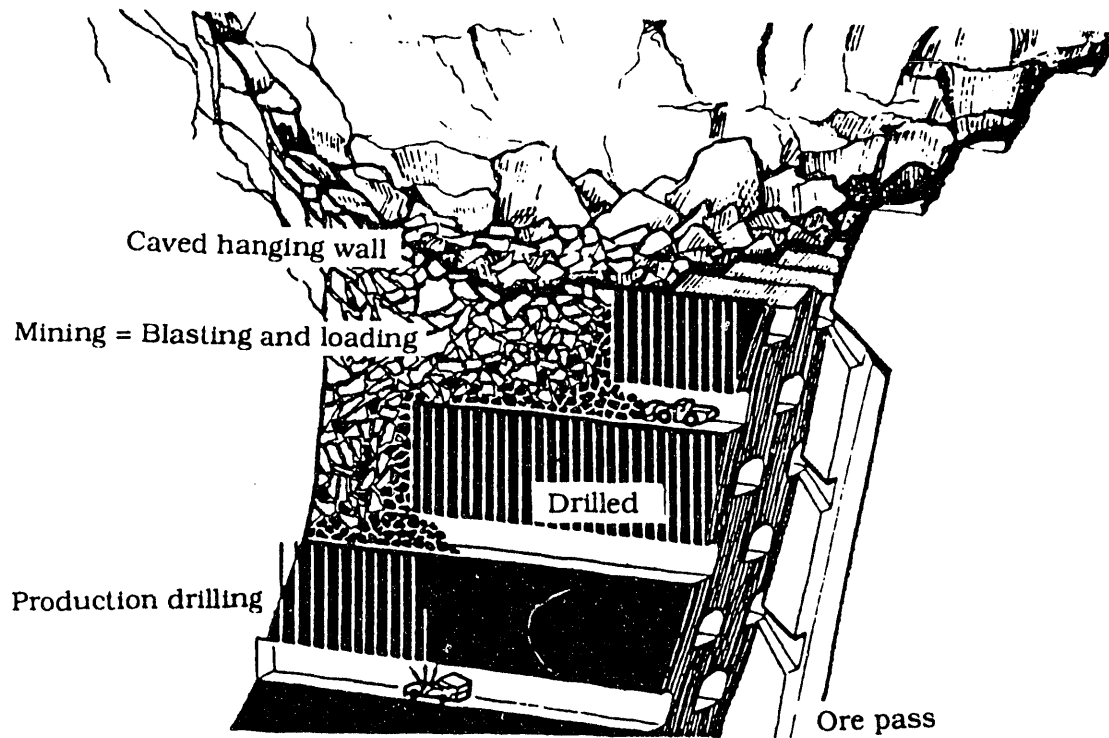

Figure 5. Sublevel Caving (Hamrin, 1986)

The fragmentation process in buffer blasting is basically the same as in all blasting operations. However, there are some differences that have been explained by Soviet scientists (Imenitov, 1970).

Breakage Related to Strain Waves

There are several modes of rock failure that are related to strain waves. When a high-pressure wave travels in rock, it is commonly called a shock wave. In the vicinity of the blast hole, the wave travels with a velocity that is greater than the speed of sound in rock. The passage of the wave can crush the rock from the borehole wall to a width that is approximately equal to the borehole diameter (Langefors and Kihlström, 1978). This crushed zone is called the shock zone. However, crushed rock is a very small part of the total fragmentation. Sometimes, depending on the detonating pressure and the coupling ratio, it may not even be possible to see the crushed zone around the borehole (Hagan and Just, 1974).

Outside the shock zone, the strain wave travels with the speed of sound (3000 to 5000 m/s in rock). This zone is called the transition zone. The width of the transition zone is about 2 to 3 times the borehole diameter. The cracks that form in this zone are dense radial cracks that extend radially out from the borehole. These radial cracks are formed by the high tensile tangential strain that is induced by the high compressive radial stress front of the wave.

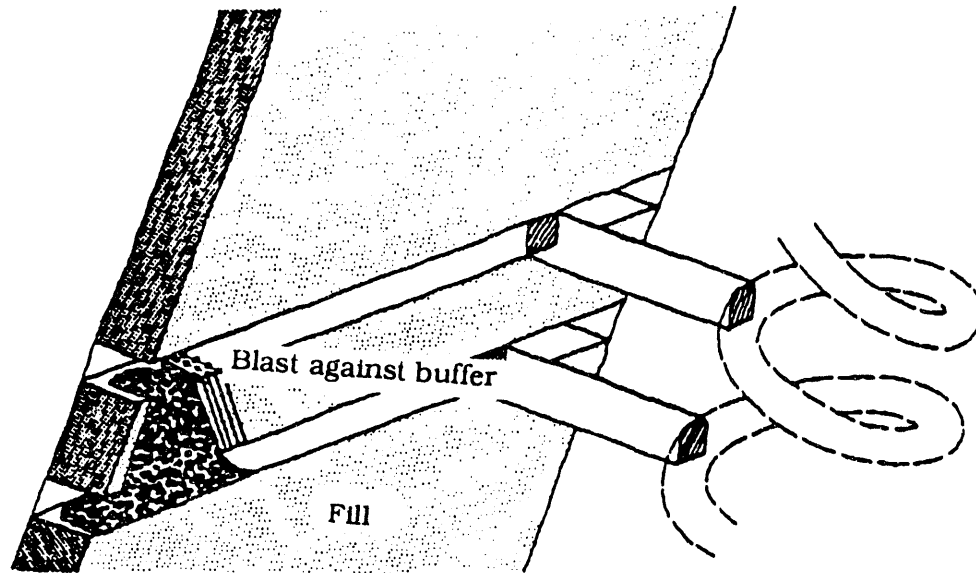

Figure 6. Rill Mining (Rustan, 1990)

It is generally agreed that radial cracks play an important role in fragmentation, mostly because they precondition the crack growth for gas pressure (Langefors and Kihlström, 1978; Hagan and Just, 1974). The strain wave loses energy by forming these cracks. The wave enters the elastic zone where the rock behaves linearly elastic. Most of the cracks in this zone are extensions of cracks from the transition zone, and it is not certain that any more new cracks are generated in the elastic zone.

The wave continues to propagate until it hits a free face. The compressive wave is then reflected as a tensile wave. This may cause spalling at the free face, but only if the blast is heavily overloaded. More important is the extension of the radial cracks and joints as the reflecting wave passes over them. Field and Ladegaard-Pedersen (1971) performed experiments with spalling plates, acoustic impedance, and surface shaping to determine the influence of the reflecting tensile wave. These experiments show that the reflected wave is very important for determining the fractures that develop and also in what direction they develop. Fractures that are perpendicular to the reflecting wave are likely to develop the greatest length because the tensile component has an optimum that is normal to the crack (Figure 7). Langefors and Kihlström (1978) conclude that even though the strain-wave energy is only 5 to 15 percent of the total explosive energy, it is important to the final fragmentation result.

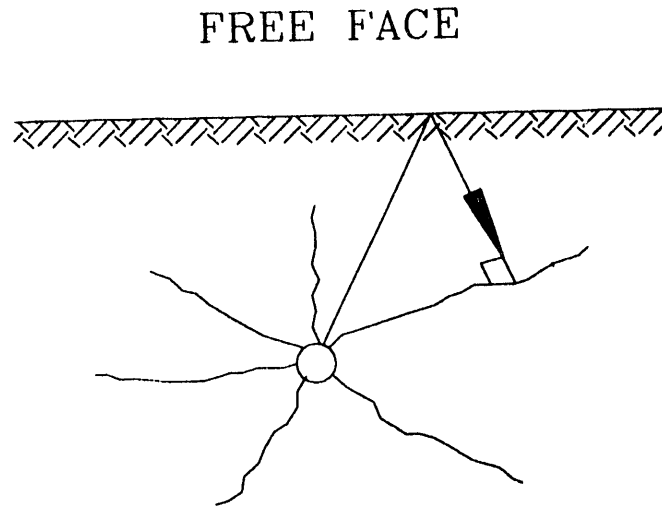

Figure 7. Reflecting Tensile Wave, Normal to the Radial Crack

Breakage Related to Gas Pressure

After the dynamic phase of the fragmentation process is complete, the remaining gas pressure extends the radial cracks that were formed by the strain wave. Gas may penetrate the open cracks and cause extension through wedging. The explosive gases also escape through the stemming column, and the energy available for gas wedging decreases. When the burden starts moving outward, the heaving effect of the blasted mass causes a shearing type of failure (Hagan and Just, 1974).

Fracturing by release of load may occur when the blast-hole pressure drops drastically. This happens when gases escape through the stemming column and radial fractures. The rock relaxes as the pressure drops, and this generates tensile stresses in the rock mass (Hagan and Just, 1974).

Fragmentation Process in Buffer Blasting

From model- and full-scale bench blast experiments, Soviet scientists formulated a theory on how the rock is fragmented in buffer blasting (Imenitov, 1970). This theory explains why fragmentation may improve when the buffer blasting technique is used.

When a single row of blast holes or the first row of several is detonated, a compressive strain wave travels radially out from the detonated charges. As the strain wave reaches the interface between the solid rock and the buffer (Figure 8), part of the wave is reflected as a tensile wave, and part of the wave is transmitted to the buffer. The reflected energy (η_{refl}) and the transmitted energy (η_{trans}) of the wave can be calculated (Imenitov, 1970).

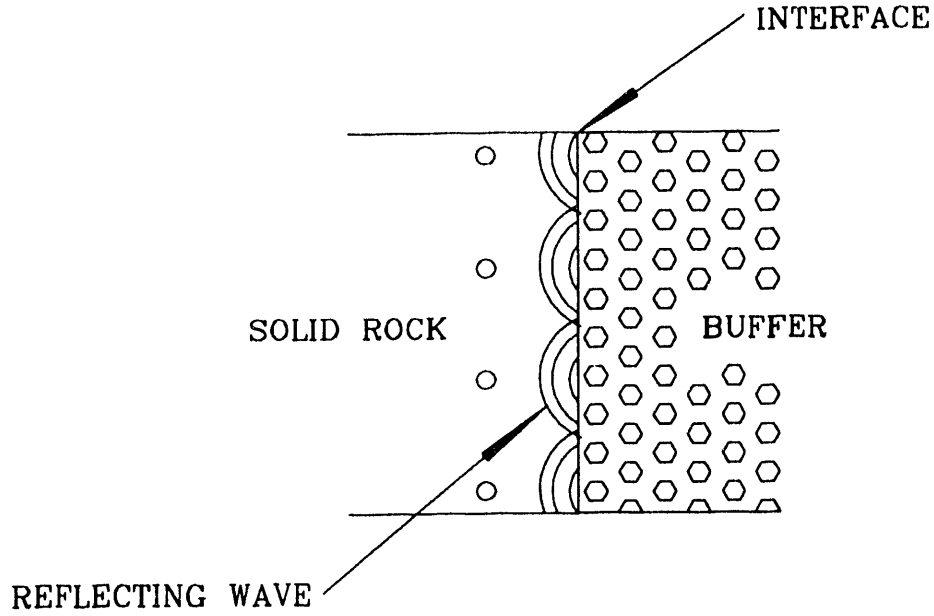

Figure 8. Detonating Charges Cause Waves to Reflect at the Interface Between the Buffer and the Solid Rock

$$\eta_{\text{refl}} = \left(\frac{\rho_1 c_1 - \rho_2 c_2}{\rho_1 c_1 + \rho_2 c_2} \right)^2 \quad (4)$$

$$\eta_{\text{trans}} = 1 - \eta_{\text{refl}} \quad (5)$$

Where ρ_1, c_1 = density and average wave velocity of the solid rock
 ρ_2, c_2 = density and average wave velocity of the buffer

If the buffer is a rubble of the solid rock that is being blasted, the density of the buffer can be expressed as a function of the density of the solid rock and the swell factor.

$$\rho_2 = \frac{\rho_1}{\text{SF}} \quad (6)$$

By using equations 4 and 6, the reflecting tensile wave can be expressed as a function of the wave velocity in the solid rock and the wave velocity and swell factor of the buffer.

$$\eta_{\text{refl}} = \left(\frac{\text{SF } c_1 - c_2}{\text{SF } c_1 + c_2} \right)^2 \quad (7)$$

Imenitov (1970) reports that the wave velocity in the buffer is mainly a function of the swell factor (Figure 9), but it is also a function of rock type and moisture content. The wave velocity in the buffer can be determined from model- and full-scale experiments.

By using equation 7 and Figure 9, the energy of the reflecting tensile wave can be calculated to be about 85 percent of the strain wave energy for normal compaction ($SF = 1.4$) of the buffer (also see Figure 10). Accordingly, about 15 percent of the strain wave energy is lost to the buffer. This is a disadvantage because the reflecting tensile wave is important for the fragmentation result.

After the dynamic phase of the fragmentation process, the gas penetrates and wedges the cracks generated by the strain wave. The duration of the shearing type of failure that occurs when the burden starts moving outward is comparable to blasting toward a free face because of the pressure from the buffer in front of the blasted slice (Imenitov, 1970). The process is slowed down, and more explosive energy must be used for fragmenting the rock.

Imenitov (1970) reports some fracturing or crushing of both the blasted slice and the buffer is likely to occur as the blasted slice is pushed against the buffer. One-row buffer blasting does not always show an improvement in fragmentation. The disadvantage with loss in the reflected tensile wave sometimes outweighs the advantages. However, Volchenko (1977) determined from model-scale experiments that one-row blasting toward a swell factor of 1.4 does improve the fragmentation. Hence, the advantages of one-row buffer blasting are (1) the duration of the shearing type of failure is longer compared with blasting toward a free face, because of the pressure from the buffer rock on the blasted slice, and (2) the blasted slice pushes the buffer rock, which may cause some fracturing of both the buffer rock and the blasted slice. The disadvantage is that there is about a 15 percent loss in the reflecting tensile wave for moderate compaction ($SF \approx 1.4$) of the buffer.

For single-row buffer blasting, there is one important factor that needs to be investigated: if there is a swell factor, x , of the buffer rock where the advantages of single-row buffer blasting always outweigh the disadvantage of a loss of energy in the reflecting wave. The loss of energy in the reflecting tensile wave for a moderate packing of the buffer is a very small part of the total explosive energy, and its negative effect on the fragmentation should not be exaggerated. The strain energy is only 5 to 15 percent of the total explosive energy (Langefors and Kihlström, 1978). Because the strain energy travels radially out from the detonated charges, only about one-third of it will be directed toward the free face or the buffer. That means that only about 1.7 to 5 percent of the total explosive energy is reflected as a tensile wave at a free face. If a buffer with moderate packing is used ($SF \approx 1.4$), about 15 percent of the explosive energy that is directed toward the buffer will be lost in the buffer. Accordingly, only about 0.2 to 0.8 percent of the total explosive energy will be lost.

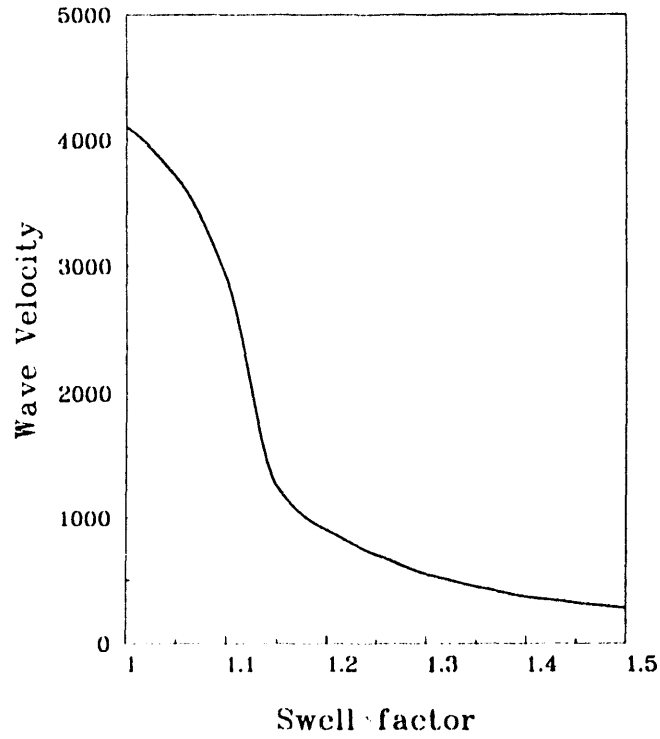

Figure 9. Wave Velocity In the Buffer as a Function of the Swell Factor (Data from Imenitov, 1970)

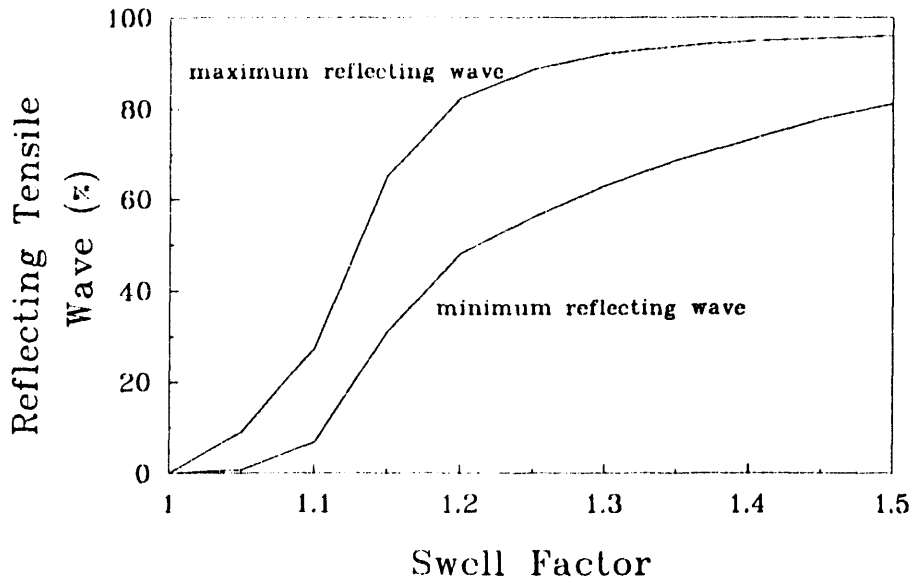

Figure 10. Reflecting Tensile Wave as a Function of the Swell Factor (Data from Imenitov, 1970)

The fragmentation process in multiple-row buffer blasting is somewhat different. After the first row is blasted, the buffer compacts, and a free space occurs between the fragmented and compacted first row and the second row. This space may have a thickness of up to 2.5 meters (Imenitov, 1970). The second row is actually blasted toward a free space and not toward the buffer. This means that 100 percent of the compressive wave will be reflected as a tensile wave at the free face.

The duration of the shearing type of failure is extended in multiple-row and single-row buffer blasting. Imenitov (1970) suggests that gas pressure from charges detonated in previous rows continues to act on the blasted slice. This pressure causes a resistance for the blasted slice to move outward. The fragmentation process is extended, and more energy is used in fragmentation. The blasted slice hits the compacted buffer with a velocity of 50-100 m/s. The compacted buffer acts like a solid wall, and the kinetic energy in the blasted slice is used for fragmenting both the blasted slice and the buffer rock. If millisecond delays are used between blasts on each row, fragments from separate rows catch up with each other and collide before they hit the buffer wall. This may also improve fragmentation.

The width of the free space that occurs between the buffer and the solid rock decreases with the number of rows blasted (or with the total thickness blasted) until it completely disappears. The part of the buffer that is close to the blast front gets more and more compacted until it is no longer possible to distinguish the solid rock from the buffer. The energy reflected as a tensile wave diminishes, and the fragmentation gets coarser. There is a limit on how many rows or how thick a layer (number of rows times the burden) can be blasted. Imenitov (1970) concludes that multiple-row buffer blasting with a short delay between the blasts improves fragmentation compared with blasting toward a free space.

Essentially, the advantages of multiple-row buffer blasting are: (1) the duration of the shearing and ripping type of failure as the burden starts moving outward is extended because of the gas pressure from the previous row blasted acting on the slice being blasted, (2) in-flight collisions between fragments from separate rows increase fragmentation when millisecond delays are used between blasts, and (3) collision between the blasted slice and the compacted buffer causes fracturing of both the blasted slice and the buffer.

Parameters Affecting Fragmentation

The parameters that affect fragmentation can be divided into three major groups: rock parameters, explosive parameters, and geometry timing parameters (Hjelmsberg, 1983). Rock parameters include compressive and tensile strength, number of joint systems, and joint frequency. Specific charge, detonation velocity, explosive density, explosive distribution in the drillhole, and coupling between explosive and rock are examples of explosive parameters (Rustan, 1981).

Hjelmberg (1983) showed that the geometry of the drilling pattern has a large influence on fragmentation. For example, a long, thin area assigned to a drill hole gives larger fragments than a compact area. Other parameters in this group that influence fragmentation are burden, spacing, delay time, and ignition pattern. In buffer blasting, important parameters for fragmentation are available swell, delay time, and blast layout.

Swell

Volchenko (1977) conducted 65 model buffer-blasting experiments on 19 mortar blocks. The 300- x 275- x 245-mm blocks were placed in a box (750 mm long, 280 mm wide, and 250 mm high) made of 10-mm sheet iron, and blasted toward a buffer of crushed mortar. The swell factors of the buffer used in the experiments were 1.3, 1.4, and 1.6. Instantaneous one-row blasting with a constant specific charge (1.47 kg of PETN per cubic meter of rock) was performed. Two or three holes were blasted per row. During the experiments, the spacing-to-burden ratio varied between 0.85 and 1.78, whereas the burden times the spacing was kept constant at 36 cm². The evaluation of the fragmentation result was based on the mean fragmentation diameter, yield of fragments over 40 mm, and degree of crushing on the buffer material.

The best fragmentation result was obtained when blasting toward a buffer with a swell factor of 1.4 (Figures 11 and 12). A swell factor of 1.4 gave the smallest mean fragmentation diameter, lowest yield of fragments over 40 mm, and highest degree of crushing of the buffer material. The optimal spacing-to-burden ratio in these experiments was 1.4.

In 1980, at the Swedish Detonic Research Foundation (SveDeFo), Jarlenfors and Holmberg conducted model-scale experiments on how void volume affects the fragmentation result (Holmberg, 1981). Single-row blasts and multiple-row blasts with delay between the blasts were performed on small models in a box made of sheet metal. The hole diameter was 1.5 to 2 millimeters, and the explosive used was PETN. Eight rows were fired, either sequentially toward the void volume (Figure 13), or instantaneously in the row with a short time delay between the rows. Three different overall void volumes were used in the experiment (swell of 12, 17, and 100 percent) The results indicated that the best fragmentation was achieved when blasting toward a free space with a swell of 100 percent. The void volume with 12 percent swell showed the coarsest fragmentation. No experiments were performed toward a free space with a swell between 17 to 100 percent. The experiments showed that when one row at a time was blasted without removing the rock from the previously blasted row, the fragmentation became coarser as the swell decreased. They also found that multiple-row blasts, with a short delay between the blasts toward a buffer, improved the fragmentation in comparison with single-row blasts toward a buffer.

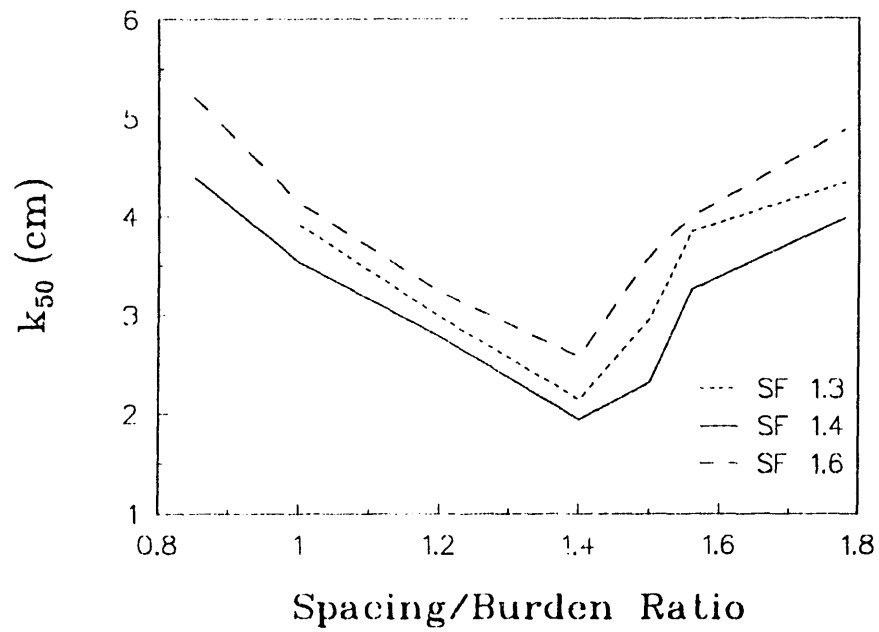

Figure 11. Mean Fragmentation Diameter (k_{50}) Versus Spacing-to-Burden Ratio for SF = 1.3, 1.4, and 1.6 (Data from Volchenko, 1977)

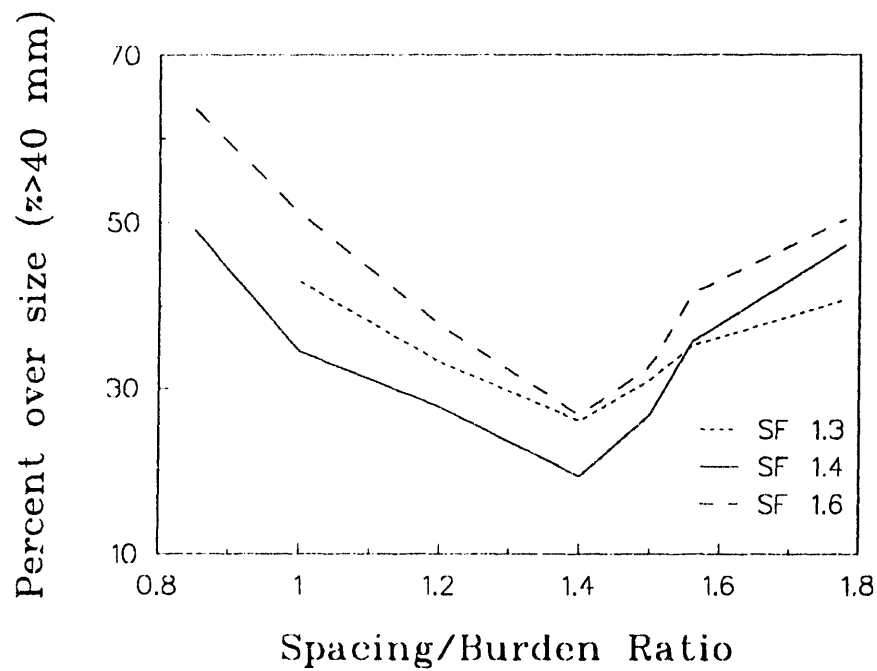

Figure 12. Yield of Blasted Material that is Over Size (>40 mm) Versus Spacing-to-Burden Ratio for SF = 1.3, 1.4, and 1.6 (Data from Volchenko, 1977)

SveDeFo, in cooperation with LKAB (a Swedish mining company), continued the work by Jarlenfors (Rustan, 1990) by conducting half-scale, buffer-blasting experiments in an iron ore mine in northern Sweden between 1982 and 1986 (Olsson, 1988). Benches (1.4 x 0.7 x 0.7 m) were blasted toward a free space of various sizes (various overall swell) contained by a concrete wall (Figure 14). Each bench consisted of five rows, with three holes in each row. The explosive used was PETN, with a specific charge of 2.3 kg per cubic meter of rock. The spacing-to-burden ratio used was 1.25. The rows were blasted row by row toward the open space. Muck from each blast (one row) was not removed and screened until the last row was blasted. The first row in every bench was blasted toward a free space, the next row toward a buffer with a swell, and the last row toward a buffer with limited swell. The overall swell of the free spaces used was 10, 20, 30, 50, and 100 percent.

It is difficult to draw conclusions from these experiments regarding which is the best swell factor to use, because each row was blasted toward a free space or a buffer with different swell factors. In addition, all the material from one bench (five rows) was sifted together. However, blasting toward a fragmented rock volume with a limited swell gives better fragmentation results than blasting toward a free space.

Feodorenko and Kovtun conducted model-scale experiments to determine the influence of the void-volume shape and relative volume on fragmentation (Holmberg, 1981). Blasting toward a free space with different shapes with swells ranging from 3 to 100 percent was tested (Figure 15). The results of these tests show that the formation of cracks occur at a minimum swell of 6 percent. A slot of rectangular shape (where blasting took place simultaneously from opposite sides of the slot) with a swell of 30 to 34 percent gave the best fragmentation result (void volume c in Figure 15).

Occidental Oil Shale Inc. performed full-scale blasting experiments for modified in situ retorting at their Logan Wash site near Grand Junction, Colorado (Hustrulid et al., 1984). In modified in situ retorting, one part of the retort is mined, and the remainder is rubble toward the mined open space. Eight retorts were constructed; all had different dimensions, blasting layouts, and expansion volumes. The yield of oil was one indication that the fragmentation was even and of the right size. Conclusions on which swell factor to use for optimum fragmentation are difficult to draw from these experiments because all the retorts had different blasting plans and different stope plans. However, the best yield of oil was achieved with a swell of about 40 percent.

Timing

The delay time in buffer blasting has to be considered to attain a high degree of fragmentation. Research from the Soviet Union (Imenitov 1970) suggests that multiple-row buffer blasting with a short delay should be used for the best fragmentation results. Apparently, delays between the holes in each row were not used in these experiments. This means that the interhole delay was only the scatter in delay between the caps within the rows. The interrow delays used in these

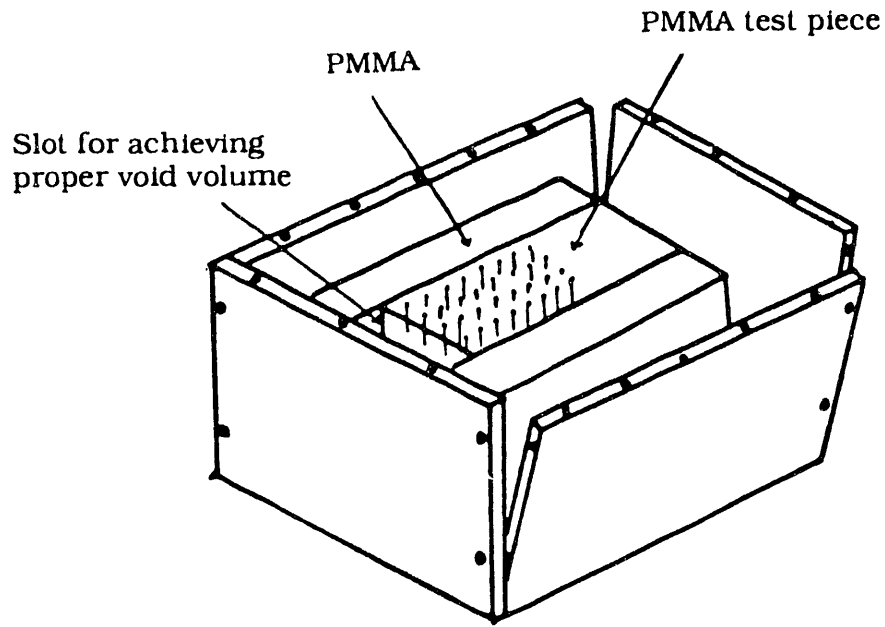

Figure 13. Experiment Setup (Holmberg, 1981)

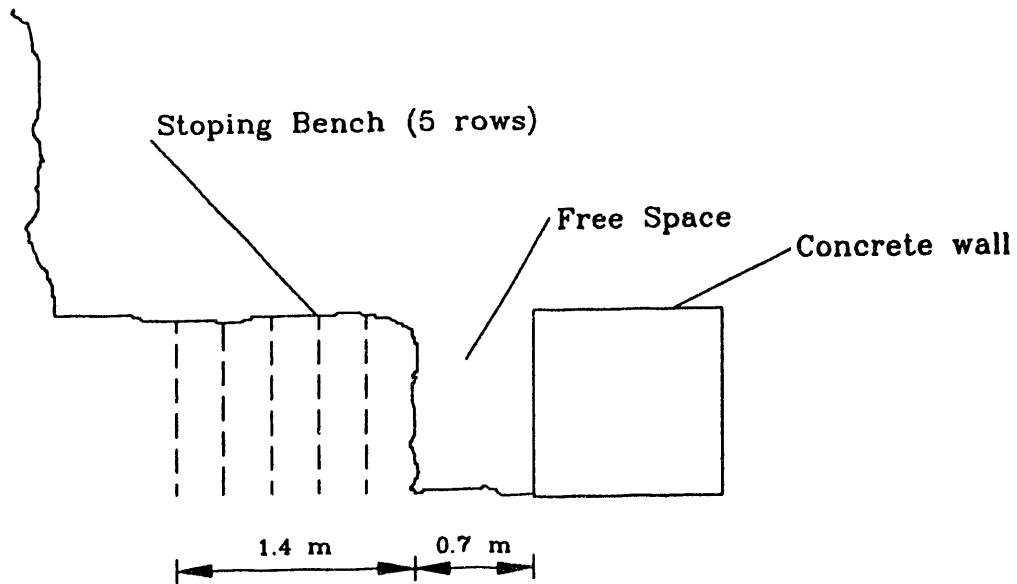

Figure 14. Side View of Experiment Setup (50 percent overall swell)

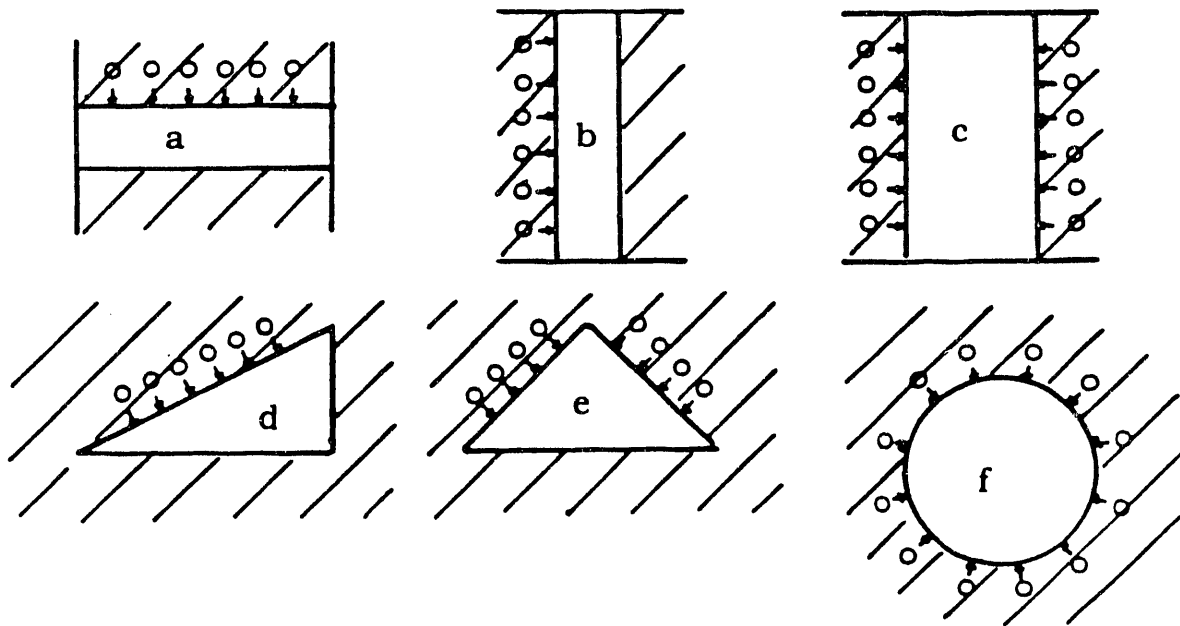

Figure 15. Shapes of the Void Volumes (Holmberg, 1981)

experiments were 8 ms/m of burden. Imenitov (1970) also suggests that the interrow delay should be 50 percent longer for buffer blasting than for blasting toward a free space. This provides time for the row being blasted to displace the buffer and make a free space for the next row. Many blasting researchers (Langefors and Kihlström, 1978; Hagan, 1977; Norell, 1985) suggest a delay of 2 to 8 ms/m of burden for optimum fragmentation results in blasting toward a free space. The delay suggested by Imenitov (8 ms/m of burden) is, in this case, about 50 percent longer than the average suggested by researchers for blasting toward a free space. However, Imenitov (1970) does not mention if any blasts with an interhole delay or any other initiation pattern have been tried. It is currently accepted that row-by-row blasting with the delay between the blasts is not necessarily the optimum initiation pattern that yields optimum fragmentation results (Langefors and Kihlström, 1978).

Volchenko (1977) tried six different schemes of multiple-row short-delay blasting toward a buffer with 40 percent swell in his model-scale experiments. He suggests that interhole delay patterns will improve the fragmentation. However, interhole delay patterns cause less displacement of the buffer, and there is less swell available for subsequent rows. A consequence of this is that fewer rows can be blasted at once. Volchenko, therefore suggests that the holes in the first row should be blasted on the same delay. This will displace the buffer as much as possible. Then, the holes in the subsequent rows can be blasted with any delay pattern that favors fragmentation.

If large-diameter (100-250 mm), 20-200 m long holes are used, it is favorable to shoot each individual hole on a separate delay to reduce vibration. It is reasonable to assume that if each hole is blasted on a separate delay, the compaction of the buffer will be less than if all holes in the first row detonate with the same delay. The thickness of the layer being blasted or the number of rows being blasted will have to decrease such that the buffer does not become overcompacted (see the Buffer Compaction and Draw Control section). However, from the literature search, it was not possible to determine what happens to the fragmentation when each hole is blasted on a separate delay. Single-hole or multiple-hole buffer blasting with an interhole delay of 2 to 8 ms/m of burden may improve the fragmentation compared with blasting toward a free space.

Blast Layout

Markenzon (1967) recommends that the same blasting parameters should be used for buffer blasting as in blasting toward a free space. However, in multiple-row blasting, the first row blasted requires about 2 to 3 times more explosive than the other rows (Markenzon, 1967). Practical experience in buffer blasting shows that the first row requires an explosive energy of 7.75 to 10.05 MJ/m³ of rock. The average explosive requirement for a whole section is about 6.28 MJ/m³ of rock for hard, competent rock (Volchenko, 1977). This corresponds to a specific charge (kg explosive per cubic meter of solid rock broken) of 1.7 kg/m³ to 2.2 kg/m³ for the first row, and to a specific charge of 1.4 kg/m³ for the whole section if a slurry explosive with a weight strength of 1.2 relative ANFO is used.

The relative weight strength of an explosive, E, in the United States is defined as the amount of calculated energy per weight available in that explosive in relation to a reference explosive (Atlas Powder Co., 1987). Commonly, ANFO is used as the reference explosive. For example, an explosive with an E of 120 (relative ANFO E = 100) has 1.2 times more calculated energy per weight (MJ/kg) than ANFO.

Imenitov (1970) suggests that the burden should be slightly larger for the first row than for the other rows in multiple-row buffer blasting with a short interrow delay. This will reduce the damage to the holes that is caused by the previous blast.

Fragmentation Prediction by Empirical Formulae

Currently, there are basically two methods available for predicting fragmentation: computer simulation models and empirical formulae. Empirical formulae for predicting the fragmentation size can be used to describe how a change in the blasting parameters will affect the fragmentation size. They can also be a helpful tool for estimating the maximum fragmentation size for equipment selection and system design. All equations are developed from multiple-hole bench blasts toward a free face in model- and full-scale experiments. Several of these empirical formulae will determine only the mean fragmentation diameter (k₅₀) and not the fragmentation size distribution.

Size Distribution

The fragmentation distribution can be described by various equations. The following equations have been used in describing size distributions in mining applications (Clark, 1987; Shu Lin, 1988).

Rosin-Rammler distribution:

$$y = 1 - e^{-\left(\frac{x}{x_c}\right)^n} \quad (8)$$

or expressed in terms of mean fragmentation size (k_{50})

$$y = 1 - e^{-(\ln 2) \left(\frac{x}{k_{50}}\right)^n} \quad (9)$$

Gates-Gaudin-Schumann distribution:

$$y = \left(\frac{x}{k_g}\right)^m \quad (10)$$

Gaudin-Meloy distribution:

$$(1 - y) = 1 - \left(\frac{x}{x_0}\right)^r \quad (11)$$

where y is the mass fraction passing; k_g is the maximum fragmentation size; and n , m , r , x_c , and x_0 are constants for the distribution. The constants n , r , and m are commonly called the fragmentation gradients (Clark, 1987). The constants for the distributions are best determined from a linear plot of the fragmentation data. Equations 8-11 can be rewritten into a linear form:

Rosin-Rammler:

$$\ln[-\ln(1 - y)] = n[\ln(x) - \ln(x_c)] \quad (12)$$

where n is the slope of the line, and $n \ln(x_c)$ is the intercept of the vertical axis (y'), where $y' = \ln[-\ln(1 - y)]$.

Gates-Gaudin-Schumann:

$$\ln(y) = m[\ln(x) - \ln(k_g)] \quad (13)$$

where m is the slope of the line, and $m \ln(k_g)$ is the intercept of the vertical axis (y'), where $y' = \ln(y)$.

Gaudin-Meloy:

$$\ln(1 - y) = r[\ln(x_0 - x) - \ln(x_0)] \quad (14)$$

where r is the slope of the line, and $r \ln(x_0)$ is the intercept of the vertical axis (y'), where $y' = \ln(1 - y)$.

The Rosin-Rammler equation is the equation most widely used to describe fragmentation distributions for blasting in mining. Faddeenkov found that the Rosin-Rammler equation fit data for blasted material from small-scale experiments (Clark, 1987). The equation has also been used by Cunningham (1983, 1987) for fragmentation size distribution. The Rosin-Rammler equation appears to describe both fine- and coarse-size material better than the Gates-Gaudin-Schumann or Gaudin-Meloy equations (Shu Lin, 1988). Harris (1968) reports that the Gates-Gaudin-Schumann equation fits the fine-size region from a blast. The Gaudin-Meloy equation better describes coarser fragment size distributions caused by explosives (Shu Lin, 1988).

Empirical Formulae for Fragmentation Size

All empirical formulae used today for predicting the fragmentation size include parameters from the three major groups of factors that affect fragmentation: a rock parameter, an explosive parameter, and a geometry parameter. The delay time and the swell factor available are very important to the fragmentation result in buffer blasting. However, none of the empirical formulae today include a timing factor or a swell factor.

It is possible to incorporate a timing factor into most of the empirical formulae. Norell (1985) performed model-scale experiments to determine how delay time affected mean fragmentation size (k_{50}). He concludes that an interhole delay of 2 ms/m of burden decreased mean fragmentation size by a factor of 1.8 compared with instantaneous blasts. If a fragmentation improvement factor (here, a factor of 1.8) can be expressed as a function of the delay time used, then this function can be incorporated in the formulae for estimating the mean fragmentation size (k_{50}). A swell factor can be incorporated in the fragmentation size estimation in the same way that the timing factor is incorporated.

Kuznetsov's Formula. Kuznetsov (1973) studied models of different materials and found that the mean fragmentation size (k_{50}) can be expressed as:

$$k_{50} = \frac{A}{100} \left[\frac{V}{Q_{TNT}} \right]^{0.8} Q_{TNT}^{1/6} \quad (15)$$

where Q_{TNT} is the amount of TNT in the drill hole (kg), and V is the rock volume broken per blast hole (m^3). Variable A is a rock factor that can be related to the uniaxial compressive strength of the rock; it is based on Protodyakonov's scale of rock hardness(f).

A = 7 for medium hard rocks (f = 8-10)
 = 10 for hard but highly fissured rocks (f = 10-14)
 = 13 for very hard, weakly fissured rocks (f = 12-16)

Equation 15 was modified by Cunningham (1983) using the relative weight strength concept. The variable Q is the amount of explosive (kg) in the drill hole.

$$k_{50} = \frac{A}{100} \left[\frac{v}{Q} \right]^{0.8} Q^{1/6} \left[\frac{E}{115} \right]^{-19/30} \quad (16)$$

SveDeFo-Nitro Nobel Formulae. SveDeFo and Nitro Nobel AB, a Swedish explosive manufacturer, predicted the mean fragmentation diameter (k_{50}) for bench blasting using an equation that was originally developed by Langefors and Kihlström (Hjelmberg, 1983). The equation, based on full-scale tests, is:

$$k_{50} = 0.44 S_L f \left[\frac{h}{l_d} \right] (SB)^{0.29} \left[\frac{B}{S} \right]^{0.145} \left[\frac{c}{Q_{DxB}} \right]^{1.18} \quad (17)$$

where S_L is a blasting factor introduced by Larsson (1973). S_L is 0.60 for highly fractured rock, 0.55 for fractured rock, 0.45 for almost homogeneous rock, and 0.4 for homogeneous rock (Rustan and Shu Lin, 1987). The hole spacing (S) and the burden (B) are both in meters. The rock constant, c, was introduced by Langefors and Kihlström (1978) and has a value of 0.4 for blasting with Dynamex-B (DxB) in granite. The function $f(h/l_d)$ is a function of the uncharged part of the hole (h) and the hole length (l_d). It was introduced by Larsson (1973) (Figure 16). The specific charge (q_{DxB}) is the amount of Dynamex-B (kg) per cubic meter of rock broken.

Helmberg (1983) modified equation 17:

$$k_{50} = 0.28 S_L f \left[\frac{h}{l_d} \right] (SB)^{0.29} \left[\frac{B_{max}}{\sqrt{SB}} \right] \left[\frac{c}{Q_{DxB}} \right]^{1.18} \quad (18)$$

where B_{max} is the maximum burden or longest distance from the hole to the edge of the area that is assigned to each drill hole. The relative weight strength (s) of Dynamex-B relative ANFO (1.0) is 1.10 (Holmberg, 1982). This modifies these equations to:

$$k_{50} = 0.49 S_L f \left[\frac{h}{l_d} \right] (SB)^{0.29} \left[\frac{B}{S} \right]^{0.145} \left[\frac{c}{q} \right]^{1.18} s^{-1.18} \quad (19)$$

$$k_{50} = 0.31 S_L f \left[\frac{h}{l_d} \right] (SB)^{0.29} \left[\frac{B_{max}}{\sqrt{SB}} \right] \left[\frac{c}{q} \right]^{1.18} s^{-1.18} \quad (20)$$

where s is the Swedish relative weight strength of the explosive relative to ANFO and q is the specific charge. These two terms are introduced in equations 19 and 20. The variable s has a slightly different definition from the U.S. definition of relative weight strength, E . Also, s accounts for the volume of explosive gases per weight of the explosive (m^3/kg) released during blasting (Holmberg, 1982). The equation for determining s contains two terms: one accounts for the calculated energy content per weight of the explosive (MJ/kg), and the second accounts for the volume of the explosive gases released per weight of explosive during blasting (m^3/kg).

$$s = \frac{5}{6} \left[\frac{Q}{Q_{\text{ref}}} \right] + \frac{1}{6} \left[\frac{V}{V_{\text{ref}}} \right] \quad (21)$$

where s = relative weight strength of the explosive
 Q = calculated energy of the explosive (MJ/kg)
 Q_{ref} = calculated energy of the reference explosive (MJ/kg)
 V = volume of gas released per weight of explosive (m^3/kg)
 V_{ref} = volume of gas released per weight of the reference explosive (m^3/kg)

Kuz-Ram Model. The Kuz-Ram model was developed and modified by Cunningham during the 1980s (Cunningham, 1983; 1987). The model is based on work done by Lownds (1983), and the results were compared with model- and full-scale tests. The model has been widely applied to South African mining conditions and has proved to be realistic. This fragmentation model uses Kuznetsov's equation (eq. 16) for the mean fragmentation size with a new method of estimating the rock factor A . The fragmentation size distribution is described with the Rosin-Rammler equation (eq. 8). Cunningham reports that the fragmentation gradient, n , in the Rosin-Rammler equation varies with spacing-to-burden ratio (S/B), drilling accuracy (W), blast hole diameter-to-burden ratio (D/B), explosive mismatch between the bottom charge length (BCL), column charge length (CCL), and charge length-to-bench height ratio (T/H). The standard deviation of W is given in meters, as are all the other variables.

$$k_{50} = \frac{A}{100} \left[\frac{V}{Q} \right]^{0.8} Q^{1/6} \left[\frac{E}{115} \right]^{-19/30} \quad (22)$$

$$n = \left[2.2 - 0.014 \frac{B}{D} \right] \left[\frac{1}{2} + \frac{S}{2B} \right]^{0.5} \left[1 - \frac{W}{B} \right] \left[\frac{|BCL - CCL|}{L} + 0.1 \right]^{0.1} \frac{L}{H} \quad (23)$$

According to Cunningham, the Rosin-Rammler fragmentation gradient, n , varies from 1.8 to 2.2. At a fragmentation study at the Swedish Research Mine in Kiruna, the fragmentation gradient varied between 0.65 to 1.81 (Hjelmberg, 1983). A high fragmentation gradient gives a uniform size distribution, whereas a low fragmentation gradient gives a larger amount of both fines and coarse material (Figure 17).

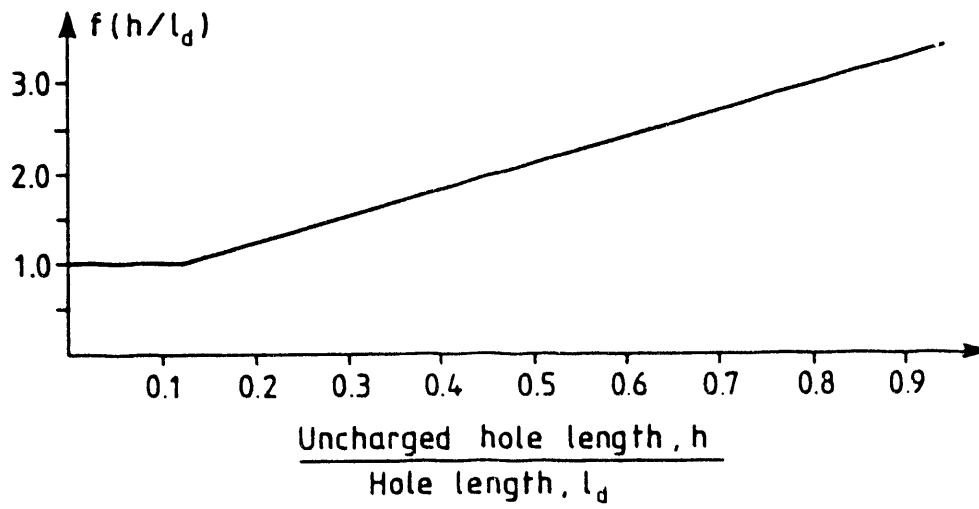

Figure 16. Function $f(h/l_d)$ (Shu Lin, 1988)

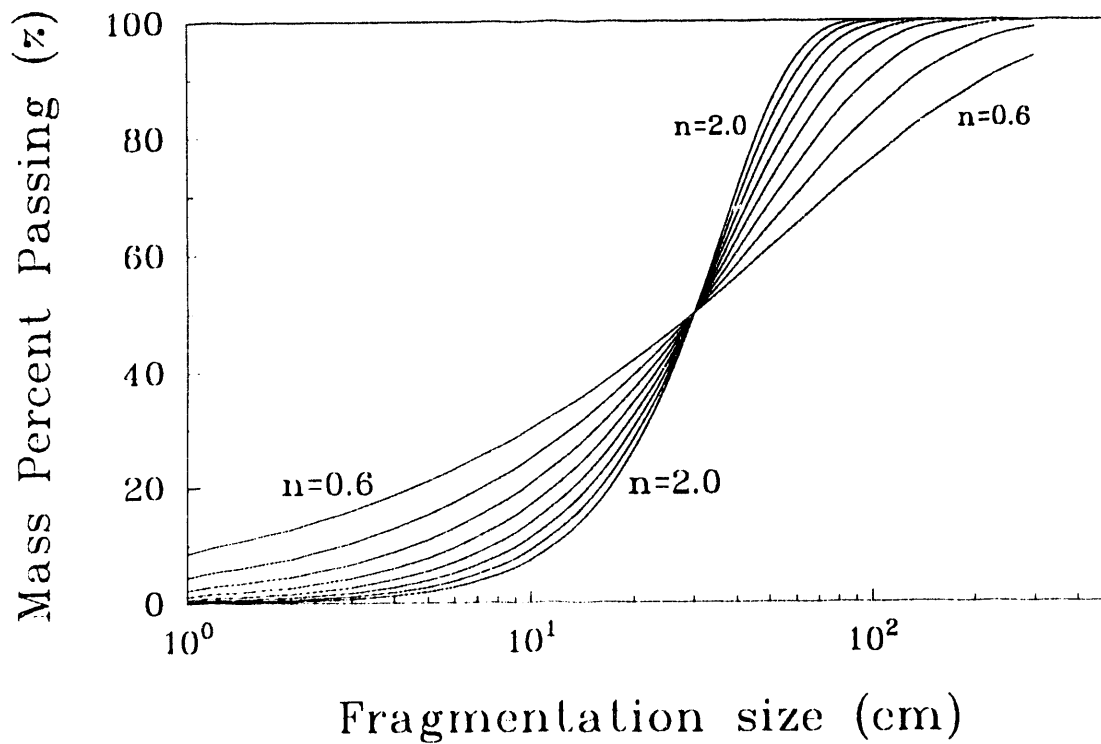

Figure 17. Fragmentation Gradient in the Rosin-Rammler Distribution.

The rock factor, A, used in the Kuz-Ram model is the blastability index of Lilly (1986) where RMD is the rock mass description, JF is the joint factor, RDI is the rock density influence, and HF is the hardness factor. Table 1 describes the terms used to determine A.

$$A = 0.06 (RMD + JF + RDI + HF) \quad (24)$$

Table 1. Determination of Rock Factor A

RMD = Rock Mass Description

- = 10 Powdery, friable rock
- = Vertically jointed rock
- = 50 Massive Rock

JF = Joint Factor

= Vertical Joint Spacing (JPS) + Joint Plane Angle (JPA)

JPS = 10 if JPS is less than 0.1 m

= 20 if JPS is greater than 0.1 m, but less than oversize

= 50 if JPS is greater than oversize to drill pattern size

JPA = 20 if JPA dips out of the face

= 30 if JPA strike is perpendicular to the face

= 50 if JPA dips into the face

RDI = Rock Density Influence (25 x RD - 50)

where RD is density in ton/m³ of rock

HF = Hardness Factor

= E/3 (GPa) if E < 50 GPa

= UCS/5 (MPa) if E > 50 GPa

where E = Young's modulus of the rock (GPa)

UCS = Uniaxial Compressive Strength of the rock (MPa)

Buffer Compaction and Draw Control

Imenitov (1970) reported on research and experiments with full-scale buffer blasting in the Soviet Union at the 6th International Mining Congress. This paper was translated into Swedish from Russian by LKAB in the mid-1970s.

To develop an efficient mining method based on buffer blasting, research and full-scale experiments started at the Moscow Mining Institute and at the Zyrjanov in 1956. The Zyrjanov mines ore bodies are hard competent rock that is steeply dipping (50-80°) with an ore width of 20 to 60 meters. The most commonly used mining method was large-hole stoping (hole diameter 100 or 150 mm) with buffer blasting, but sublevel stoping with buffer blasting was also used.

In addition to the production experiments (e.g., swell factor, number of rows blasted), it was also necessary to determine the mechanics of how the fragmented buffer compacts during blasting. Measurements of compaction of the buffer were done in both full- and model-scale experiments. Metal rods, 2 to 4 m long, were placed in the buffer, and their displacement during the blast was measured. By measuring the detonation wave velocity in the buffer, both the packing and the shock-wave energy transmitted into the buffer could be determined.

The results of these experiments show that the zone of compaction (i.e; the width of the zone that compacts during the blast) is about 30 m in a full-scale blast. Closest to the stoping bench, there is a loose-packed zone up to 2.5 m wide. During the blast, a void space is created closest to the bench. However, after the blast, fragmented rock falls into this void space, creating a loose-packed zone (Figure 18). In multiple-row blasting with a short delay between the rows, it is reasonable to assume that the void space that is created after each row is blasted does not cave in before the next row is blasted. Thus, each row is blasted toward a free space (Imenitov, 1970).

The displacement of the buffer rock when blasting is greatest close to the stoping bench, and it decreases with the distance away from the bench (Figure 19). Accordingly, the swell factor is smallest close to the bench, and increases with the distance away from the bench (Figure 20). The thickness of the layer that is being blasted (i.e., number of rows times the burden) affects the thickness of the loose-packed zone and the linear displacement of the buffer rock closest to the bench at the blast front (Figures 21 and 22). One purpose of these full-scale experiments was to determine how many rows or how thick a layer could be blasted without over compacting the buffer and still achieving a high degree of fragmentation. Figure 21 shows that 24 m is the maximum layer thickness that can be blasted before the free space diminishes and the buffer gets hard-compacted close to the blast front. This means that if the burden is 5 m, a maximum of five rows with a short delay between the blasts can be used for this experiment. The thickness of the loose-packed zone will likely vary with the swell factor of the buffer. A buffer with a large swell factor will most likely have a wider, loose-packed zone than a harder, compacted buffer (Imenitov, 1970).

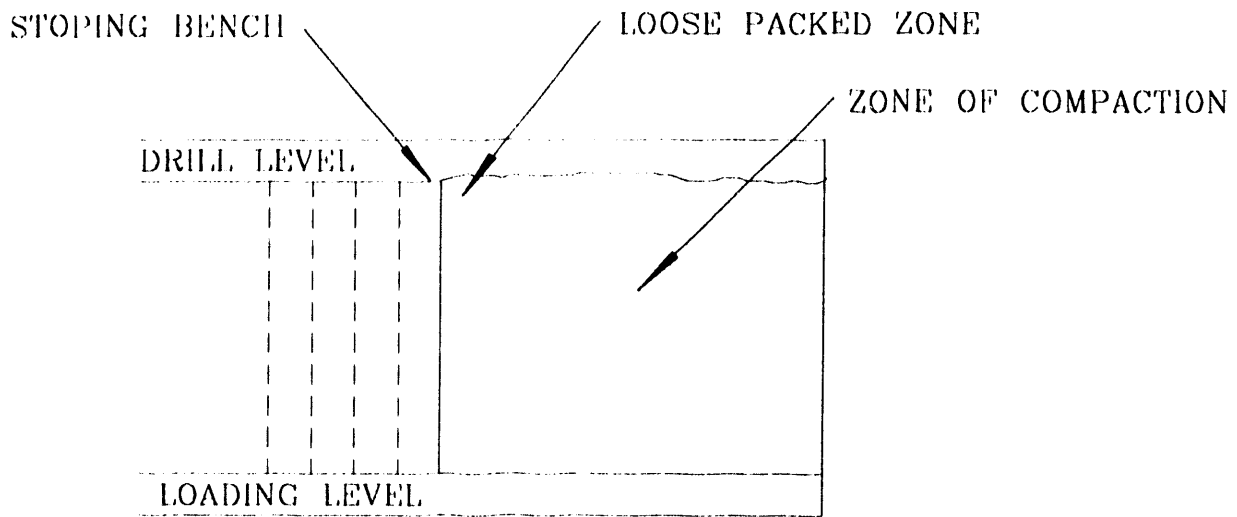

Figure 18. Side View Showing the Stopping Bench, the Zone of Compaction, and the Loose-Packed Zone

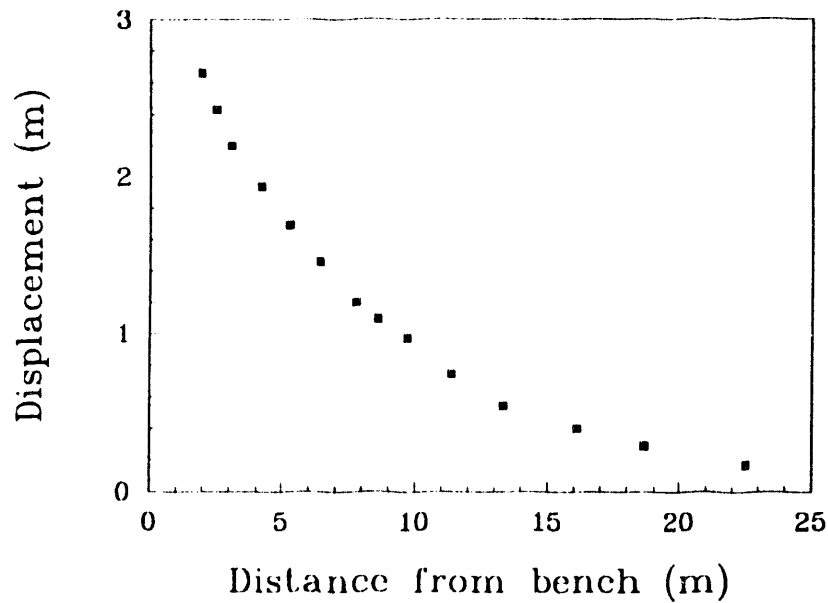

Figure 19. Displacement of the Buffer Versus the Distance Away from the Bench (Data from Imenitov, 1970)

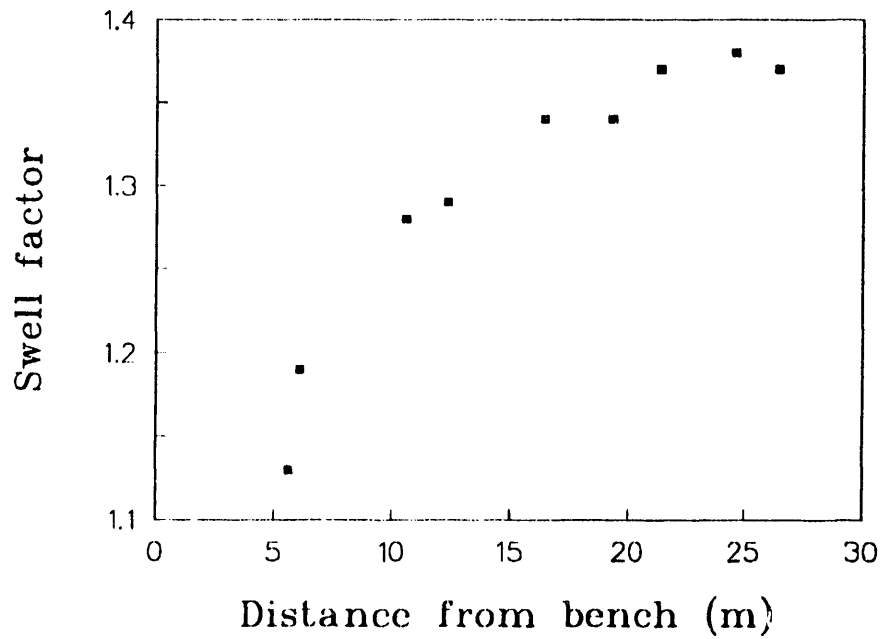

Figure 20. Swell Factor of the Buffer Versus the Distance Away from the Bench (Data from Imenitov, 1970)

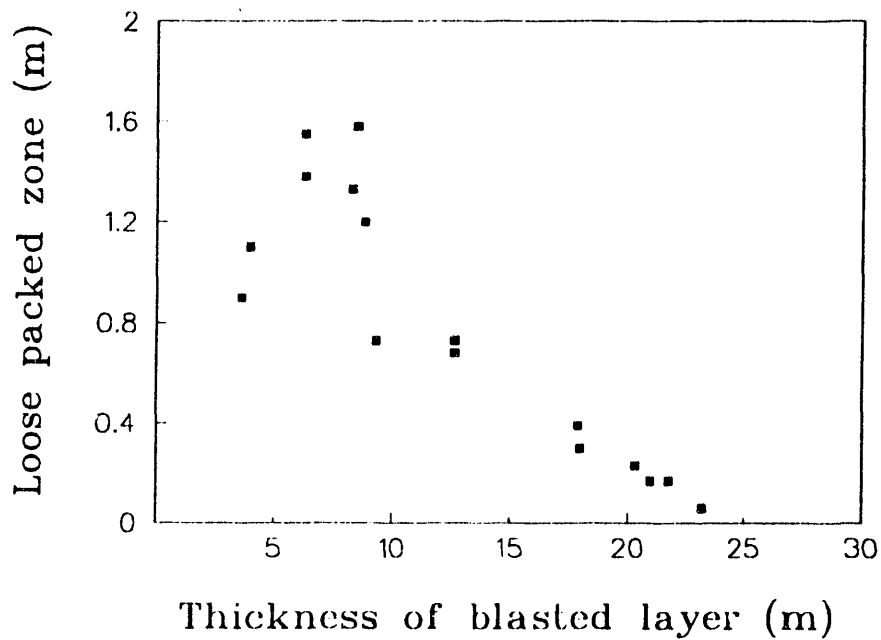

Figure 21. Loose-Packed Zone Versus the Thickness of the Blasted Layer (Data from Imenitov, 1970)

The amount of rock that has to be drawn out from the buffer to achieve an even packing before the next blast can be calculated using equation 25 and Figure 20. Assume that the loading drifts are 8 m apart and that the optimum swell factor for optimum fragmentation results is 1.4. Also, assume that the achieved swell factor of the buffer, after the blast, is the one given in Figure 20. The percentage of rock that has to be drawn out from the loading drifts to achieve the optimum swell factor at a distance (x) from the blast front is:

$$\% \text{ Rock drawn } (x) = 100 \left[\frac{SF_0(x)}{SF_a(x)} - 1 \right] \quad (25)$$

where at distance x from the blast front $SF_0(x)$ is the optimum swell factor after the rock is drawn out, and $SF_a(x)$ is the swell factor after the blast. The results from these calculations are summarized in Table 2.

Table 2. Percentage of Rock Drawn Out Calculated for an Optimum Swell Factor of 1.4

| x (m) | SF _a | Amount of Rock to be Drawn Out (%) |
|-------|-----------------|------------------------------------|
| 8 | 1.22 | 15 |
| 16 | 1.32 | 6 |
| 24 | 1.37 | 2 |

This simple analysis is only possible if the swell factor distribution in the buffer after the blast is known. In this case (Figure 20), Imenitov (1970) used a full-scale experiment by measuring the wave velocity in the buffer. If the swell factor distribution in the buffer could be calculated somehow, this would aid in designing the buffer and the blast layout.

Markenzon (1967) analyzed data from Imenitov and expressed the linear displacement of the buffer as function of the distance, x, from the stoping bench (blast front) (Figure 23).

$$S = S_0 e^{-kx} \quad (26)$$

where S = Displacement (m) at distance x from blast front
 S_0 = Displacement (m) at the blast front (x = 0)
k = constant

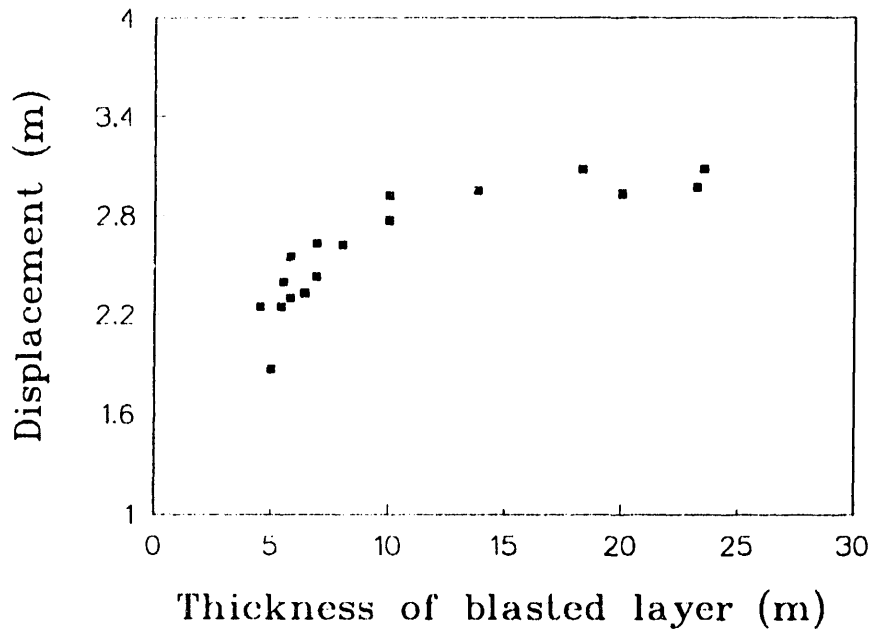

Figure 22. Displacement at the Blast Front Versus Thickness of the Blasted Layer (Data from Imenitov, 1970)

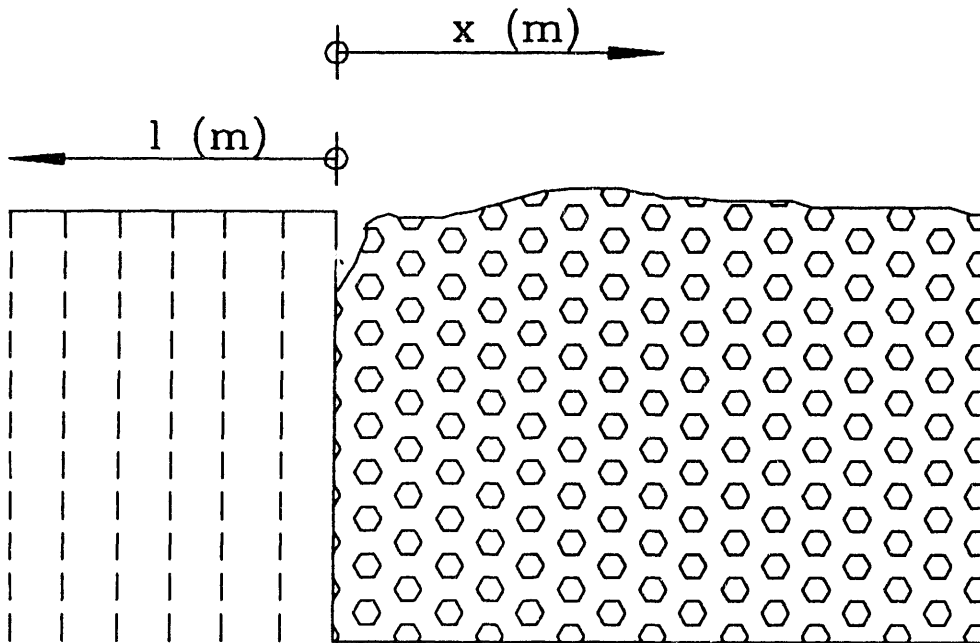

Figure 23. Side View Showing the Stopping Bench, the Distance x , and the Thickness of the Blasted Layer, l

Markenzon (1967) claims that S_0 varies almost linearly with the swell factor in the buffer and that k is almost constant. Table 3 summarizes the equations for S tabulated by Markenzon. Note that S_0 probably is the average displacement at the blast front for various thicknesses of the layer, l , that is being blasted.

Table 3. Summary of Equations of Displacement (Markenzon 1967)

| SF | $s = s_0 e^{-kx}$ |
|------|----------------------|
| 1.5 | $s = 3.6 e^{-0.18x}$ |
| 1.2 | $s = 1.9 e^{-0.17x}$ |
| 1.08 | $s = 1.3 e^{-0.19x}$ |

Markenzon (1967) also showed that the relative compaction of the buffer can be determined by differentiating S with respect to x .

$$\frac{\delta S}{\delta x} = -k s_0 e^{-kx} \quad (27)$$

where $\delta S/\delta x = \Delta$ is the relative compaction (i.e, the relative swell factor of any point x in the buffer). The factor $-kS_0$ can be written as Δ_0 . The factor Δ_0 is the relative compaction at the face of the blast front. Equation 27 can be rewritten as

$$\Delta = \Delta_0 e^{-kx} \quad (28)$$

and the swell factor distribution in the buffer can now be determined:

$$SF_{\text{initial}}(x) + \Delta(x) = SF_{\text{final}}(x) \quad (29)$$

where SF_{initial} is the swell factor in the buffer before the blast, and SF_{final} is the swell factor in the buffer after the blast.

Because the minimum swell factor in the buffer is always greater than 1:

$$SF_{\text{final}}(x \geq 0) > 1 \quad (30)$$

Since the swell factor distribution in the buffer can be approximated and calculated in this manner, equation 25 can be used to calculate how much rock has to be drawn out from the buffer (at a certain distance from the blast front) after each blast. However, the compaction and free space available for the layer being blasted toward the buffer are still unknown.

The displacement of the buffer at the blast front (S_0) varies with the thickness of the layer, l , that is being blasted (in meters in Figure 22). A plot of S_0 versus l can be determined from relatively simple full-scale experiments. Markenzon (1967) showed how to use this graph to analyze the space available for each row that is being blasted toward the buffer. The swell of blasted rock is about 20 to 30 percent ($SF = 1.2$ to 1.3) for blasting both toward a buffer and toward a free space. About 5 to 10 percent of the swell is vertical and sideways. This means that about 15 percent of the swell is due to the forward displacement of the buffer. However, in stope blasting, it may be reasonable to assume that the lateral swell is greater than 15 percent, because there is no sideways swell. If the forward swell is 15 percent, then a 10-m-thick slice will be 11.5 m thick after blasting, and the swell will be 1.5 m.

In Figure 24, the displacement at the blast front (S_0), the swell, and the free space available are plotted against the thickness of the blasted slice, l . The free space available that occurs between the blast front and the buffer will be equal to the difference between S_0 and the swell curves. Figure 24 shows that the free space available is fully used when l is 30 m. This means that 30 m is the maximum possible thickness of the blasted layer.

A question that still remains is which l should be chosen for optimum fragmentation. Full- and model-scale experiments have shown that multiple-row blasts with millisecond delays give the best fragmentation results (Imenitov, 1970; Volchenko, 1977). Depending on which burden is chosen, the swell available for each row blasted can be determined using Figure 24 (Markenzon, 1967). Assume, for example, that rows with a 3-m burden are blasted toward the buffer using the free space available in Figure 24. For the fifth row blasted ($l = 15$ to 18 m), a 16-m free space is available. The lateral swell can be calculated by dividing the free space available (1.6 m) by the thickness of the row (3 m) being blasted into that free space; the lateral swell is 53%. A total swell of 63 percent is available (10 percent added for vertical and lateral swell).

A curve can be constructed with the swell available for each 3-m layer (or any layer thickness) (Markenzon, 1967). Figure 25 was constructed from Figure 24 using a burden of 3 m. Accordingly, if the amount of swell is known that is required for good fragmentation results for blasting toward a free space, the maximum thickness of l that is being blasted can be determined. For example, if a swell of 40 percent is required for good fragmentation, a maximum thickness of 22 m should be blasted.

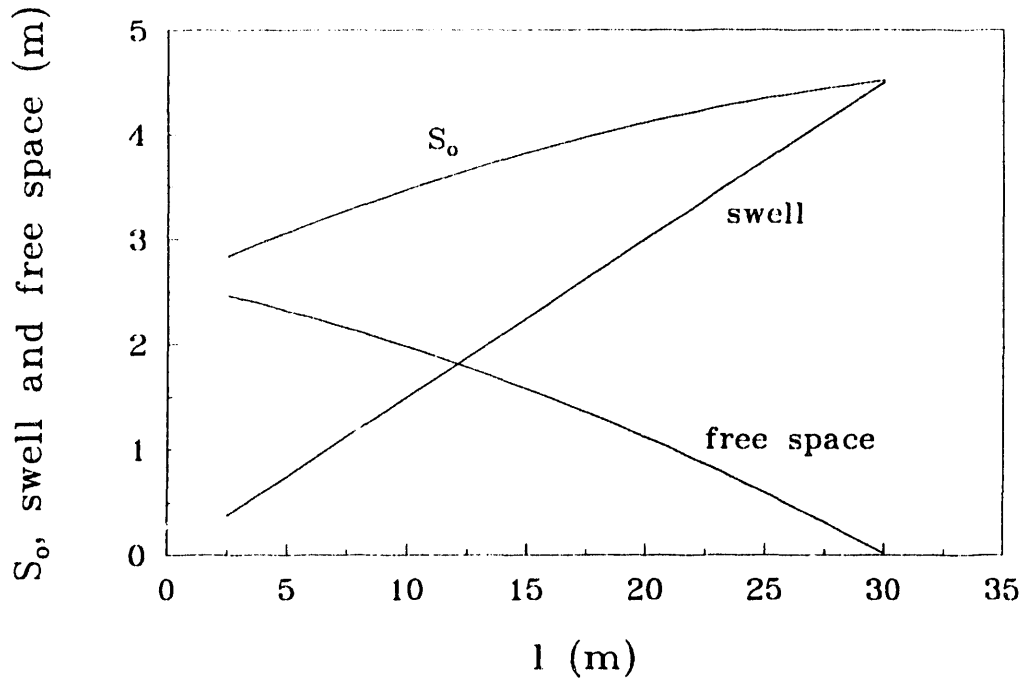

Figure 24. S_0 , Swell, and Free Space Available Versus Thickness, l , of the Blasted Layer

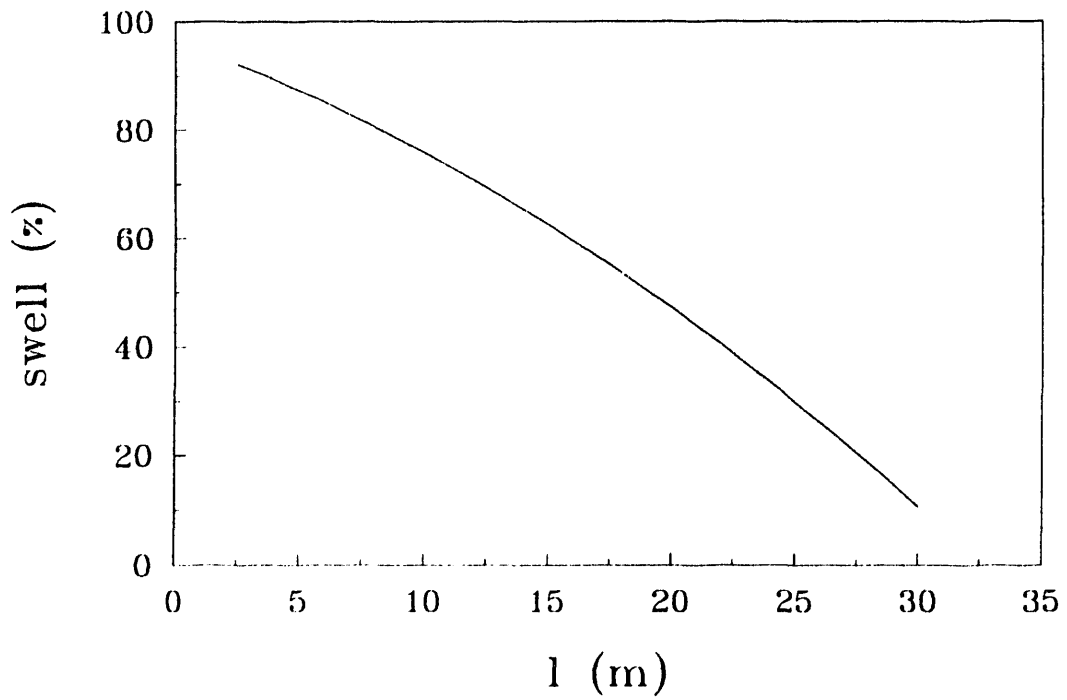

Figure 25. Swell Available For Each 3-m Row Being Blasted

Summary of Past Buffer-Blasting Studies

According to Soviet scientists, the fragmentation process in buffer blasting has some advantages compared with blasting toward a free space (Imenitov, 1970). The shearing type of failure as the burden starts moving outward may be extended because of the pressure on the blasted slice that occurs from the buffer rock or from gases from previously blasted rows. Other advantages for fragmentation include collision between fragments from separate rows (in multiple-row buffer blasting) and collision between the blasted slice and the buffer wall. Imenitov (1970) reports one disadvantage of fragmentation in single-row buffer blasting: the energy loss in the reflecting tensile wave when blasting toward a buffer. However, for moderate packing of the buffer, this energy loss is a very small part of the total explosive energy.

One of the most important parameters for fragmentation in buffer blasting is the swell available. Volchenko (1977) determined that blasting toward a buffer with a swell of 40 percent gives better fragmentation results than blasting toward a free face. Also, Olsson (1988) concluded that blasting toward a buffer with limited swell gives better fragmentation results than blasting toward a free space. Conversely, Holmberg (1981) concluded that the fragmentation size increases with the swell.

More experiments are necessary to determine the optimum swell for optimum fragmentation results for both multiple- and single-row blasts. Both blasting toward a buffer and blasting toward a free space have to be considered. In multiple-row blasting, each row is blasted toward a different swell volume. The first row is blasted toward a buffer, whereas the others are blasted toward a free space (Imenitov, 1970). Experiments should start with single-row blasts toward a buffer of different swell factors to determine the optimum swell factor for the buffer for optimum fragmentation. Also, single-row blasts toward a free space using different swell factors should be done to determine the minimum and maximum swell factor necessary to achieve satisfactory fragmentation.

Experiments regarding the delay time to use in buffer blasting are very limited. More model buffer-blasting experiments with different types of initiation patterns and delay times are necessary to determine the most favorable initiation pattern with respect to vibration caused by blasting, buffer compaction, and optimum fragmentation. The interrow and interhole delays in buffer blasting should perhaps be longer than the delays used in blasting toward a free space. For buffer blasting, Imenitov (1970) suggested a delay that is 50% longer. This is because each hole or each row that is blasted needs a longer time to provide a free space for the next hole or row being blasted. The time it takes for each hole or row to move outward may be longer in buffer blasting because the buffer and the gas pressure from the previous blast causes a resistance to outward rock movement. Precision caps, soon available on the market, will provide a means for effectively controlling the interhole and interrow delay in full scale.

In buffer blasting, the blasting plan should be determined from the blasting parameters (e.g., burden, spacing, powder factor) that are used for blasting toward a free space. However, the burden and the specific charge for the first row of charges in buffer blasting may have to be larger than for blasting toward a free face (Markenzon, 1967; Volchenko, 1977).

Empirical formulae are a helpful tool for predicting how a change in the blast plan affects the fragmentation size. Including a timing factor and a swell factor will make the formulae applicable to buffer blasting.

Markenzon (1967) presented some very useful equations and methods of analyzing the swell factor in the buffer after blasting that are based on the lateral displacement of the buffer. Markenzon also showed a method by which to calculate the swell available for each row that is blasted in multiple-row buffer blasting. The data are based on multiple-row buffer blasting with a short delay between the rows. More buffer compaction measurements are necessary to determine how different initiation patterns affect the compaction of the buffer.

Model-Scale Buffer-Blasting Experiments

The blasting experiments were performed at the experimental mine in Idaho Springs, Colorado. Seven 150- x 90- x 56-cm concrete blocks cast from leftover ready-mix were blasted toward a buffer of rubblized magnetite using different swell factors to determine the swell factor for optimum fragmentation results. Different swell factors for the buffer were achieved by sifting the magnetite into several fractions, mixing different fractions, and measuring the bulk density for the mixture. The concrete blocks were 4 to 11 weeks old when blasted and had roughly equal compressive strength.

The blasting parameters were chosen to simulate a full-scale blast in oil shale. The model-scale experiments represent a scale of 1:20. The first blasts were performed to determine the amount of explosive and to optimize the planned blasting layout. One-row or two-row blasts with a 2-ms interrow delay were blasted toward the magnetite buffer using PETN in Primacord form as the explosive. Instantaneous blasting caps or Primacord were used for ignition of the holes. The blast holes were stemmed with sand or iron ore fines.

When these blasts failed to achieve the desired fragmentation, the experimental conditions were varied. The hole spacing, interhole delay, interrow delay, number of rows blasted, blasting layout, specific charge of explosive, type of explosive, as well as the swell factor were varied to increase the fragmentation. Explosives used in the 16 blasts included PETN, Powermax 140 (ANFO based), Unigel (nitroglycerin based), and Iresplit-D.

Conclusions of Buffer-Blasting Experiments

The fragmentation results achieved in all experiments were poor; thus, no blasting experiments toward a buffer of different swell volumes were conducted. No

conclusions were drawn regarding the correct swell factor to use for optimum fragmentation results. The experimental fragmentation results consisted of fragments with the size of the burden and the spacing. The poor fragmentation results achieved can be explained by the layout (burden and spacing) of the holes in the blocks in combination with the use of precast holes.

Precast holes spaced relatively close together cause the radial cracks extending out from the blast hole to follow the line of precast holes, both parallel and perpendicular to the free face. Therefore, the fragmentation will consist of fragments of the size of the burden and the spacing and sometimes even multiples of the burden and the spacing. The use of precast holes also limits the choices of changing the blasting layout after the blocks are cast.

The spacing-to-burden ratio should have been larger for the blasting layout, especially for the instantaneous blasts. However, if a larger spacing-to-burden ratio were used, relatively poor fragmentation results would still be obtained because of the precast holes. The fractures parallel to the free face could have been diminished by choosing a layout with a spacing that was larger than the burden. This should have caused radial fractures to develop earlier toward the free face, rather than along the line of holes parallel to the free face. If a spacing-to-burden ratio larger than 1.0 had been used, fractures along the line of holes perpendicular to the free face would most likely be present. The fragmentation result would still be coarse because fractures developing along the line of holes would release the expanding gases and not use the total explosive energy.

The experiments using Unigel show that the use of a different type of explosive may be more useful. An explosive with a lower detonation velocity and slower expanding gas volume better uses the expanding gases and improves the fragmentation. In the tests with Unigel, radial cracks extended out from the blast hole in all directions, not just along the line of precast holes. However, Unigel did not detonate reliably. Because Powermax 140 is an ANFO-based explosive with slow expanding gas volume it was considered for fragmenting concrete. However, Powermax 140 did not detonate because the precast blast hole of was too small (11 mm) and caused dead pressing of the explosive.

Iresplit-D detonated reliably in 56-cm-long 6.3-mm straws. However, the fragmentation results were poor. The precast holes in the layout contributed to the poor fragmentation results. Therefore Iresplit-D should be considered for model- and half-scale blasting experiments.

A test blast with just a cap (No. 8 strength) inside the blast hole was done. It was noted that the cap is capable of splitting the concrete a distance of the burden (10 cm). Therefore, the caps should be placed outside the blast hole in model-scale experiments in order to have no influence on the fragmentation results. For the experiments with Iresplit-D, the cap was on the outside of the blast hole.

Design of Full-Scale Buffer-Blasting Experiments

More model-scale experiments would need to be run to determine optimum swell factor and optimum delay time before full-scale experiments should be run. However, research in the Soviet Union in full-scale buffer blasting suggests that a full-scale experiment with reasonable selected blasting and buffer parameters is possible.

Full-scale experiments should be designed to compare fragmentation that is achieved using blasting toward a free face with fragmentation achieved using buffer blasting. Imenitov (1970) reports that multiple-row buffer blasting improves the fragmentation, and single-row blasting sometimes does and sometimes does not improve fragmentation. Therefore, we suggest that multiple-row blasting should be used.

At least four experiments should be performed: two toward a buffer and two toward a free space. Two different initiation patterns should be tried. One pattern should use an interrow delay, as in the Soviet full-scale experiments; and a second pattern should use a wave plan.

We have assumed that the experiments will take place in a stope that has a width of 12 m and a stope height of 18 m. The first two experiments will be conducted toward a buffer with an even swell of 40 percent. The swell in the buffer before the blast should be greater than or equal to 30 percent to avoid over compaction when blasting (Volchenko, 1977). A buffer width of 12 to 25 m before the blast will allow the buffer to compact and make space for the rows being blasted (Figure 26). Four rows will be blasted in each experiment. The blasting parameters selected for the experiments were calculated using AECI design principles for ring blasting (AECI, 1980).

$$B S = \frac{l_c q_1}{H q} \quad (31)$$

where q_1 = Linear charge (kg) per meter of blast hole
 q = Specific charge (kg/m^3 of rock)
 l_c = Charge length (15 m)
 H = Bench height (18 m)
 B = Burden (m)
 S = Spacing (m)

The specific charges used to calculate the blasting parameters were 1.5 kg/m^3 for the first row and 1.1 kg/m^3 for subsequent rows. A slurry explosive with the density of 1200 kg/m^3 will be used. The explosive parameters for each experiment are listed in Table 4. Note that the overall specific charge assumes that the wall holes are fully loaded.

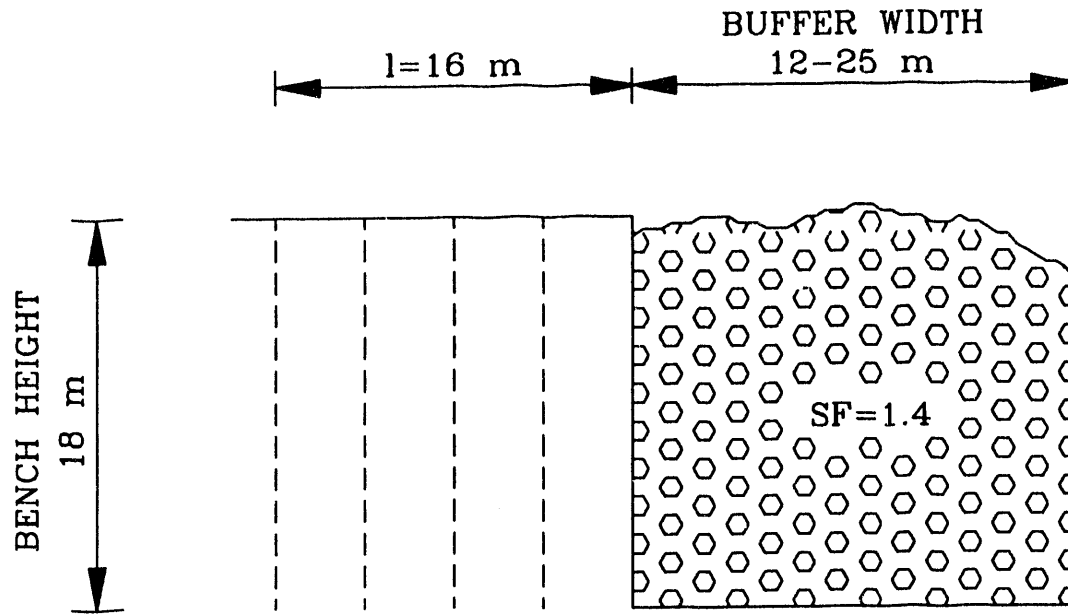

Figure 26. Side View Showing Bench and Buffer

Table 4. Explosive Parameters

| | |
|--|--|
| Explosive: | Slurry (density = 1200 kg/m ³) |
| Blast hole diameter: | 150 mm |
| Number of rows blasted: | 4 |
| Overall specific charge (row 1): | 1.8 kg/m ³ |
| Overall specific charge (row 2, 3, 4): | 1.5 kg/m ³ |
| Burden, Spacing (row 1): | 4 m, 3 m |
| Burden, Spacing (row 2, 3, 4): | 4 m, 4 m |

The interhole and interrow delay in the experiments are both 25 ms. The delay for each blast hole is indicated by a number close to the blast hole. For example, a number 1 close to a hole means that the hole has a 25-ms-delay blasting cap, whereas a number 2 indicates that the hole has a 50-ms-delay blasting cap (Figures 27 and 28).

EXPERIMENT No. 1

BLAST DIRECTION

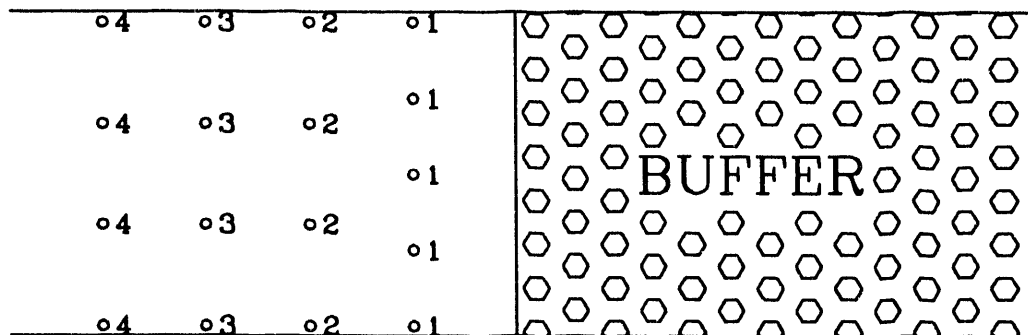
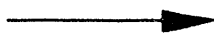

EXPERIMENT No. 2

BLAST DIRECTION

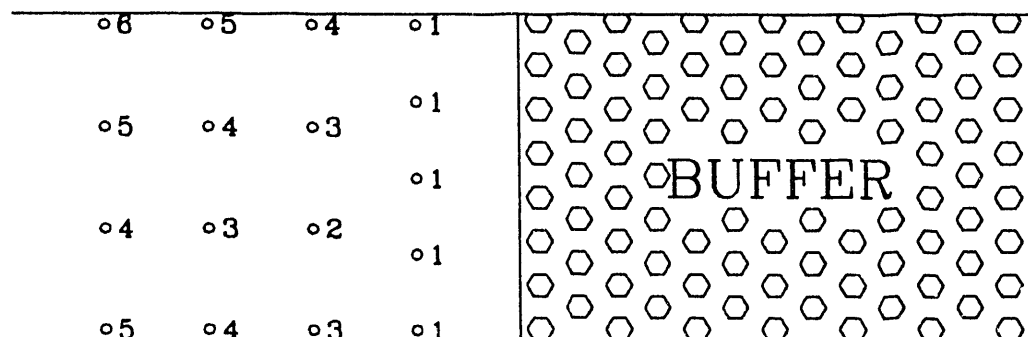
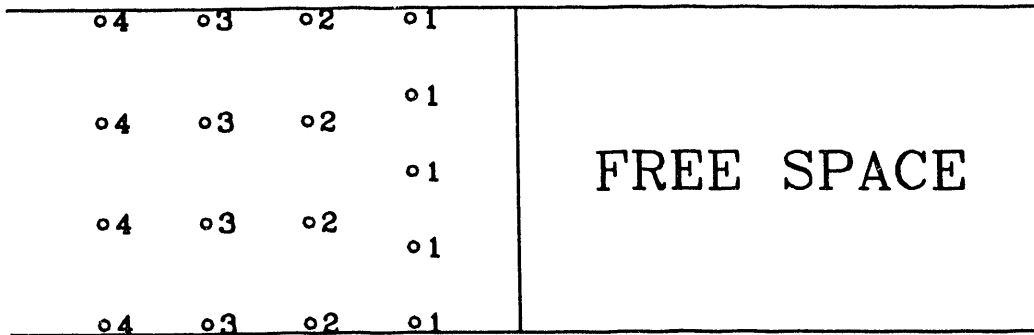
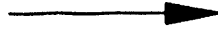

Figure 27. Experiments No. 1 and No. 2

EXPERIMENT No. 3

BLAST DIRECTION



EXPERIMENT No. 4

BLAST DIRECTION

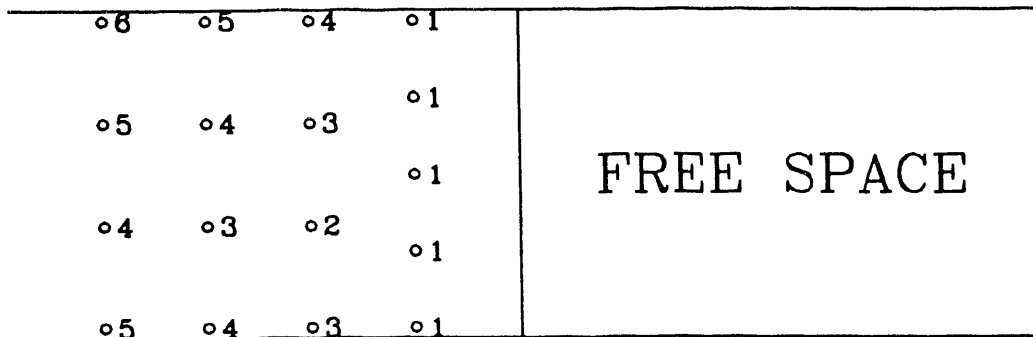

Figure 28. Experiments No. 3 and No. 4

During the experiments, the fragmentation achieved in experiments 1 to 4 should be carefully compared (Figures 27 and 28). Photographs can be used to assess the fragmentation size and the fragmentation distribution. Observations and visual inspection of the blasted material can be used to determine how the buffer compacts when blasting with an interrow delay of 25 ms (experiment 1) compared with using another type of initiation pattern (experiment 2). The backbreak for the four different experiments should be compared. It is likely that larger backbreak will occur when blasting toward a buffer than when blasting toward a free space.

TWO METHODS FOR MINING OIL SHALE

As part of this study, two large-scale underground mining methods are evaluated. One method is a potential new mining method called large-hole stoping. The second is conventional room-and pillar mining. The data and assumptions given in Table 5 are used in the mine design. All units are metric unless otherwise noted.

Table 5. Mine Design

| <u>Ore Data</u> | <u>Large-Hole Stopping</u> | <u>Room and Pillar</u> |
|--------------------------------|----------------------------|------------------------|
| Average thickness: | 100 m | 18 m |
| Overburden depth: | 500 m | 500 m |
| Horizontally bedded oil shale: | yes | yes |
| <u>Oil shale</u> | | |
| In situ density: | 2200 kg/m ³ | 2200 kgm ³ |
| Average grade: | 79 L/ton | 142 L/ton |
| <u>General</u> | | |
| Working days per year: | 350 | 350 |
| Shifts per day: | 3 | 3 |
| Daily production: | 75,000 ton | 75,000 ton |
| Yearly production: | 26,250,000 ton | 26,250,000 ton |
| Mine life: | 30 years | 30 years |

Mine access consists of four shafts (Table 6): One production shaft, one service shaft, and two ventilation shafts. All are located within the shaft pillar area. The production shaft has two single-drum hoists and four 60-ton skips. The hoisting capacity is estimated at 89,000 tpd for large-hole stoping and 95,000 tpd for room and pillar. This will allow a 2-hr/day transportation of employees and material. The production shaft is sunk to a depth of 650 meters for large-hole stoping and 570 m for room and pillar allowing for a 50-m loading pocket. Fully automated skip loading and hoisting are used. The other three shafts are sunk to a depth of 600

meters for large-hole stoping and to 520 m for room and pillar. The service shaft is used for service, emergency elevator, and, if necessary, intake air. All shaft sinking and construction work is carried out by contractors. Time required to finish all the shaft sinking and construction work is estimated at 3.5 years for large-hole stoping and 3.3 years for room and pillar.

Table 6. Shaft Complex

| Shaft | Size, Type, etc. | Use | Construction Time, (months) | |
|-------------|--|-------------------------------------|-----------------------------|-----------------|
| | | | Large-Hole Stoping | Room and Pillar |
| Production | 9 m diameter, 2 single-drum hoists with four 60-ton skips, loading pocket, and concrete head frame | production, employees, and material | 21 | 20 |
| Service | 9 m diameter, 1 single-drum hoist, counter weighted | service and emergency elevator | 26 | 25 |
| Ventilation | 9 m diameter | exhaust ventilation | 11 | 10 |
| Ventilation | 7 m diameter 9 m diameter | intake ventilation | 11 | 10 |

Large-Hole Stoping Method Using Buffer Blasting

This large-hole stoping method uses buffer blasting and spent shale backfill as pillar support. The advantages of a mining system like this include high mechanization and equipment use, high resource recovery, underground disposal of spent shale, and low specific development. The dimensions for stopes and pillars in this design are based on common dimensions for large-hole stoping as well as engineering judgement. The mine production is 75,000 tpd. Sufficient reserves for a mine life of 30 years were assumed. Average grades and thicknesses of the oil shale were estimated from the Colony Oil Shale Project (Figure 3).

Overall Mine Plan

Mining takes place between the Mahogany zone and the R6 zone and includes the material within these zones. The overcut is located just below the Mahogany marker to take advantage of the relatively competent rock there. The undercut is located in the R6 zone.

Mechanical miners are used for development of the overcut and the undercut. A two-entry system is used for ventilation purposes but also for flexibility. One entry is used for conveyor haulage and the other for transportation of personnel, material, and for service.

Large-diameter holes are drilled and charged from the overcut, and continuous loaders are used for extracting the oil shale from the undercut. The stopes are kept full of broken shale, emptied in the shortest possible time, and backfilled with spent shale. The stope dimensions are 100 m high, 120 m long, and 20 m wide. A stope pillar of 15 m is left between each stope, and a block pillar of 50 m is left between each mining block.

Stopes are first mined away from the area that is closest to the shaft pillar. This will minimize preproduction development. A minimum of four stopes is mined at the same time. The production from these stopes totals 61,500 tpd, with an additional 13,500 tpd from the development operation. One mining block consists of eight stopes. The development is always at least eight stopes ahead of the production. A total of 1548 stopes or 194 mining blocks will be mined during the mine life.

Overcut Level

A plan view of the overcut level is shown in Figure 29. The stopes are drilled vertically downward from the overcut to the undercut (79 m) using drilling rigs with in-the-hole drilling hammers. The drill holes are charged with slurry explosive from the overcut using diesel charging trucks. Holes may be charged to their full length and blasted or maybe charged by parts in order to minimize vibrations during blasting. Mechanical miners are used for development of the overcut. The excavated oil shale is transported by conveyor belts to a raise connected to the skip-loading pocket below the undercut and hoisted to the surface.

The overcut level is also used as a fill level for spent shale. Spent shale slurry is transported in large-diameter drillholes and/or pipes to the mined out stopes. Two stopes will always be backfilled at the same time. Backfilling of spent shale starts when two stopes that share the same loading drift on the undercut are loaded empty (Figure 30).

Loading Level/Undercut

Two stopes share the same loading drift, located in the rib pillar. Loading is carried out from loading crosscuts, connecting the loading drift with the loading trough. Production loading starts when two stopes that share the same loading drift are fully rubblized. Before full-production loading starts, the swell is removed from the stopes after each blast. When full-production loading starts, each stope is emptied in the shortest possible time (around ten days) to minimize the ground control problems caused by open stopes. Feeder breakers reduce the muck size to

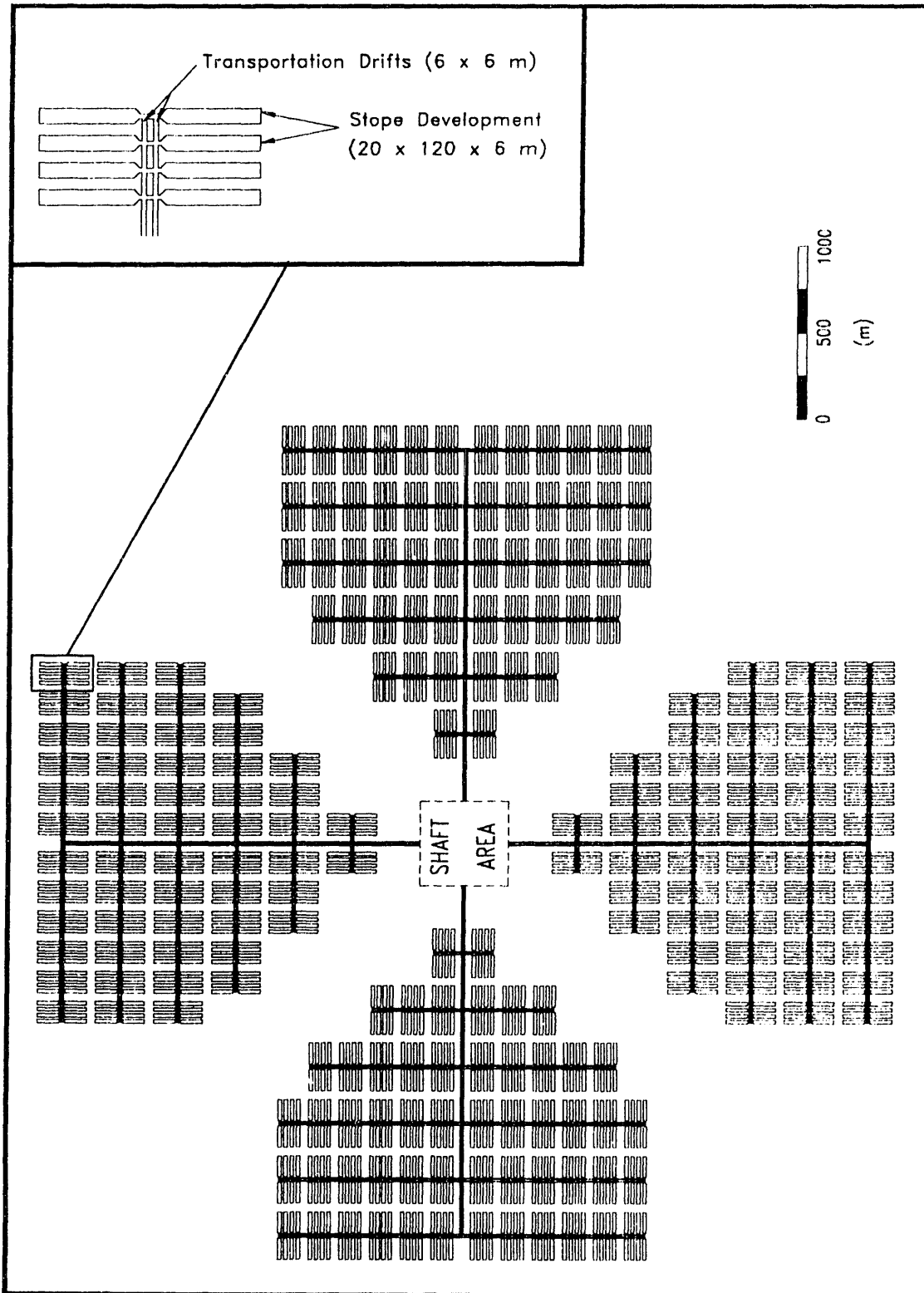

Figure 29. Plan View Overcut Level

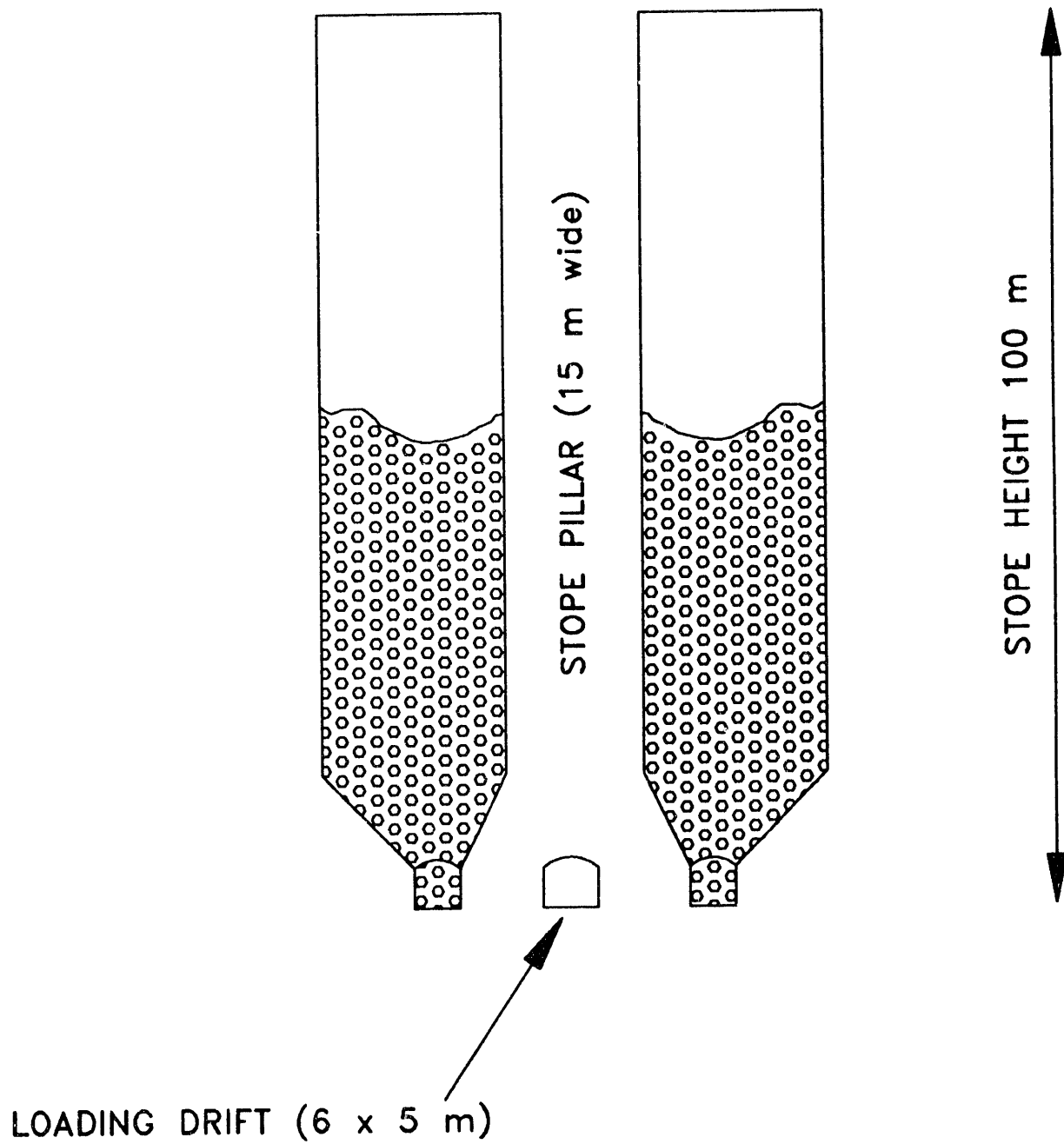

Figure 30. Cross Sections of Two Stopes Sharing the Same Loading Drift

10 to 20 cm, and belt conveyors are used for transporting the oil shale to the loading pocket. A continuous haulage system (continuous loader, feeder breaker, and conveyor belts) is used for loading and hauling the oil shale to the skip-loading pocket.

Before backfilling, large-diameter drainage pipes are placed in the bottom of the stope, and drained water will be pumped from the bottom of the stopes to the sump. Three fill walls are built on the loading level for each two stopes filled: one for the loading drift in the rib pillar and two for each of the loading troughs (Figure 30).

Mechanical miners are used for development of the undercut level. Belt conveyors transport the rubblized oil shale to the skip-loading pocket. Conventional drilling and blasting are used for development of the loading troughs. The layout for the undercut level is shown in Figure 31.

Conventional Room and Pillar Method

This room and pillar method is a panel and main design that uses rubber-tired haulage and surface disposal of spent shale. The advantages with a conventional room and pillar method includes high degree of flexibility and mobility. The method is also easily mechanized. A disadvantage is the higher specific development which leads to a longer preproduction period (74 months) compared to the large-hole stoping method (48 months). The dimensions for rooms and pillars in the design are based on the updated Scott-Ortech Cottonwood Wash Mine Feasibility Study (Synfuels Engineering, 1982). The mine production is 75,000 tpd. Sufficient reserves for a mine life of 30 years were assumed. Average grades and thicknesses of the oil shale were estimated from the Colony Oil Shale Project (Figure 3). All units are metric, unless otherwise indicated.

Overall Mine Plan

Mining occurs in the 18-m-thick Mahogany zone in a panel and main design using a double pass method (heading and benching). The mined rooms are 18 m high and 18 m wide with 24-m square pillars. The development operation consists of mining the entries (mains and submains) and the first pass (8 m). The vertical benching of the panels (i.e., the second pass, 10 m) is considered as the production operation.

Multiple-boom drill jumbos are used for drilling the first pass, and drills are used for drilling the vertical bench holes (second pass). Rotary in-the-hole drills are used for both the vertical and horizontal drilling. Front-end loaders load the oil shale onto rubber-tired trucks that transport it to the crushing station and the skip-loading pocket located in the shaft pillar area.

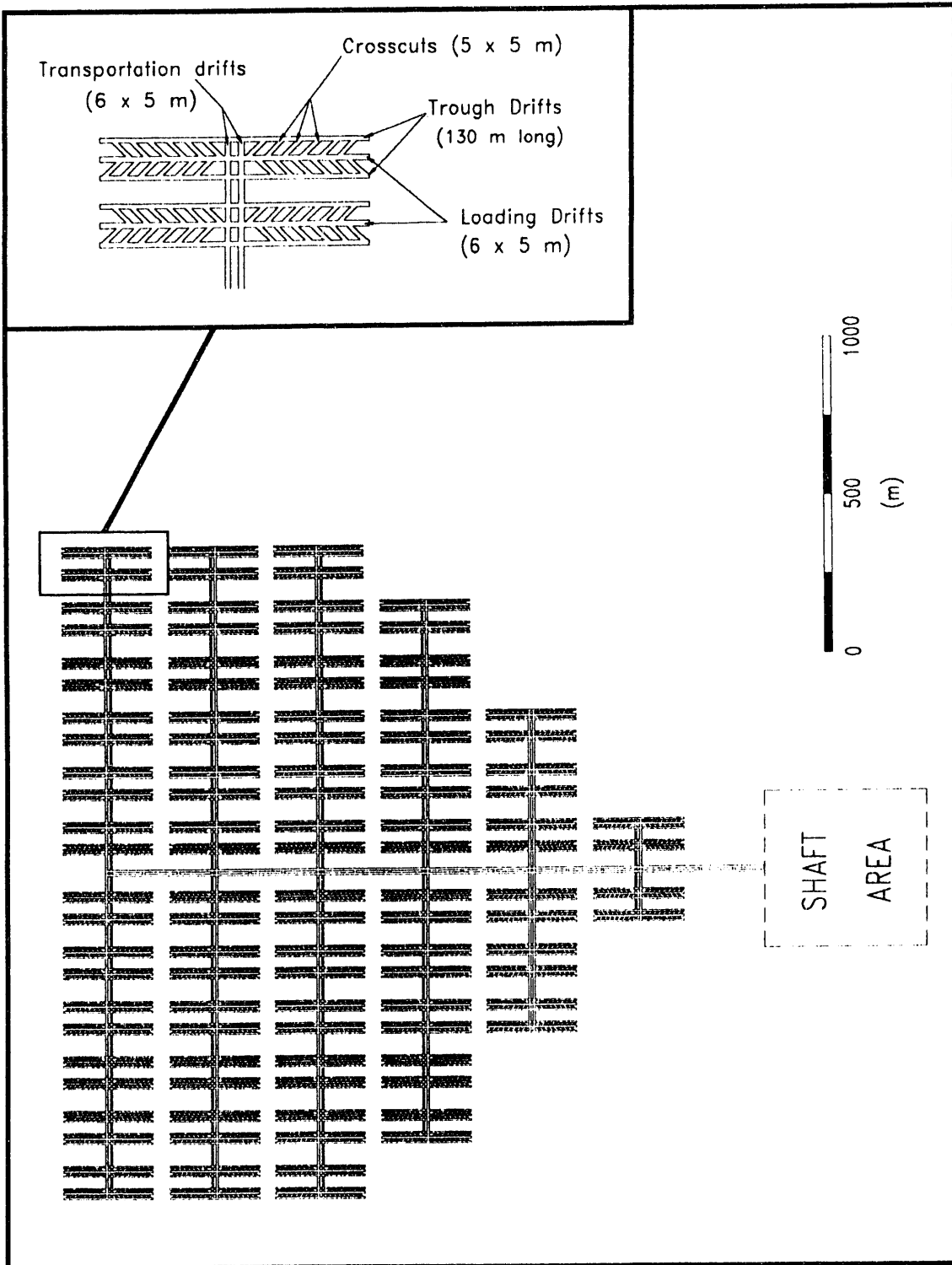

Figure 31. Plan View Undercut Level

Panels are mined away from the shaft pillar to minimize preproduction development. Each panel is 1824 m long, 900 m wide, and divided into four mining sections (each 900 m long and 438 m wide) by a 24-m-wide ventilation barrier. Each panel is separated by a 76-m-wide barrier pillar. The barrier pillars on each side of the four-entry main are selected to be 100 m. The chain pillars on each side of the submains are selected to be 58 m. For a plan view of the mine, see Figures 32 and 33.

The production from the panels is 40,800 tpd, and the development operation (first bench, mains, and submains) contributes an additional 34,200 tpd. The excavation ratio within the panel is 68 percent. A total of 67 mining sections or 17 panels will be mined during the mine life.

Preproduction Development

Preproduction development includes all the development and construction work that must be done before production can start. Preproduction includes shaft sinking and all development necessary to bring eight stopes into production (large-hole stoping) or to bring the first panel into production (room and pillar). It is assumed that two shifts per day, 22 days per month will be worked for large-hole stoping preproduction. Two shifts per day, 22 days per month will be worked for room and pillar preproduction until the first section is developed. Three shifts per day and 350 days per year will be worked for the remaining sections.

Shaft Sinking

All shaft sinking and shaft construction is carried out by contractors. The contractor will start sinking of the production and the service shaft. These two shafts are sunk simultaneously, and the estimated time for completion is 26 months for large-hole stoping and 25 months for room and pillar. When the production shaft and the service shaft are completed, sinking of the ventilation shafts starts. For estimation of costs and completion times for large-hole stoping, see Appendix A. For similar information on room and pillar, see Appendix B.

Overcut Preproduction for Large-Hole Stoping

The development of the overcut starts when the production shaft and the service shaft are completed. A contractor develops 500 m of the transportation drifts on the overcut level and a raise (3 m in diameter) connecting the overcut level with the skip loading pocket. The rest of the overcut preproduction is carried out by the mine's own personnel.

A total of eight stopes (one mining block) will be developed as the preproduction stage. Transportation drifts are selected to be 6 x 6 m, to make sufficient space for large drilling rigs and mechanical miners. Stope development drifts are 20 m wide, 6 m high, and 120 m long. All excavated areas (wall and roof) will be rock bolted in a 1.5- by 1.5-m pattern with 2.5-m-long resin-grouted bolts.

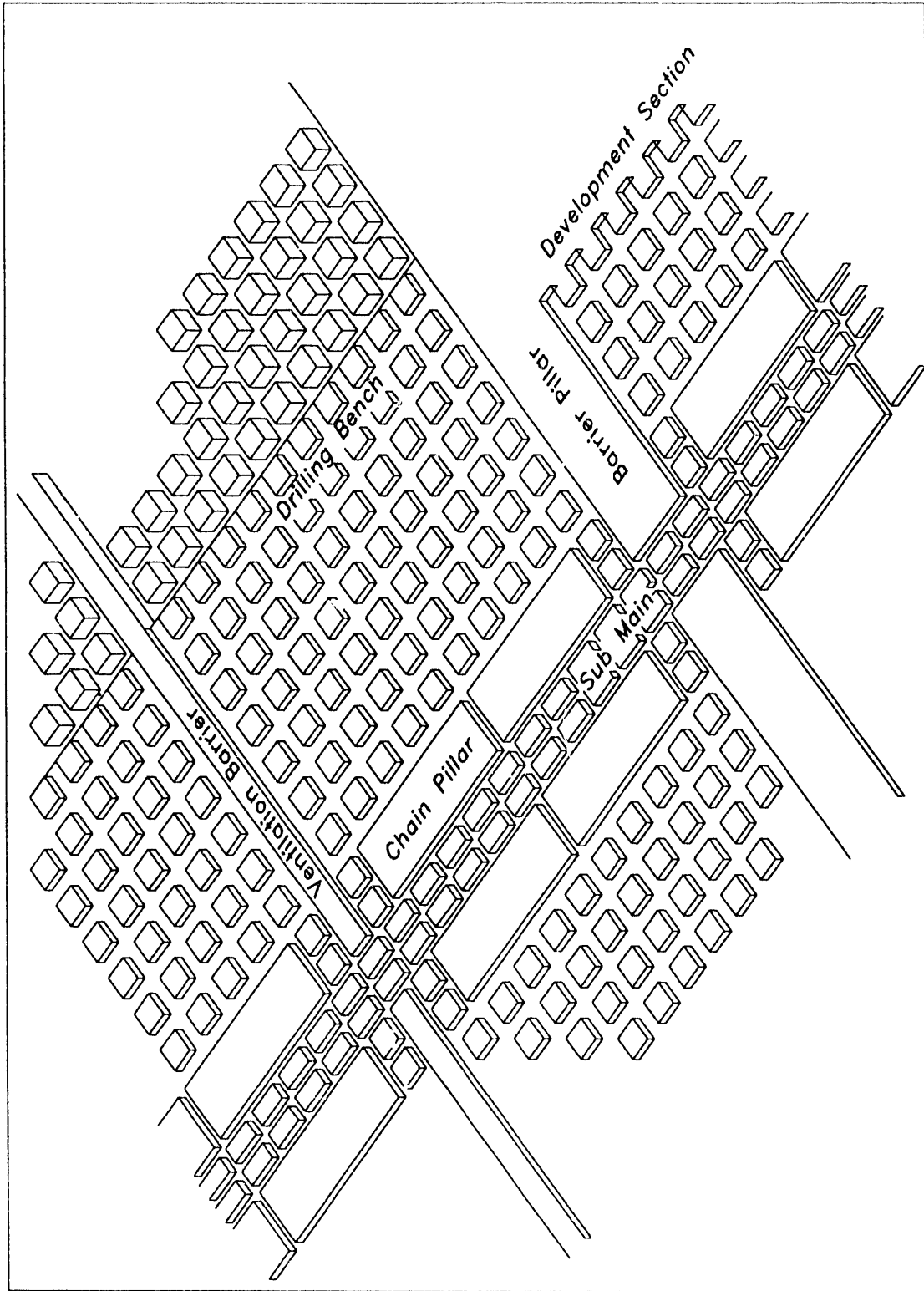

Figure 32. Isometric View of the Mining Section (Synfuels Engineering, 1982)

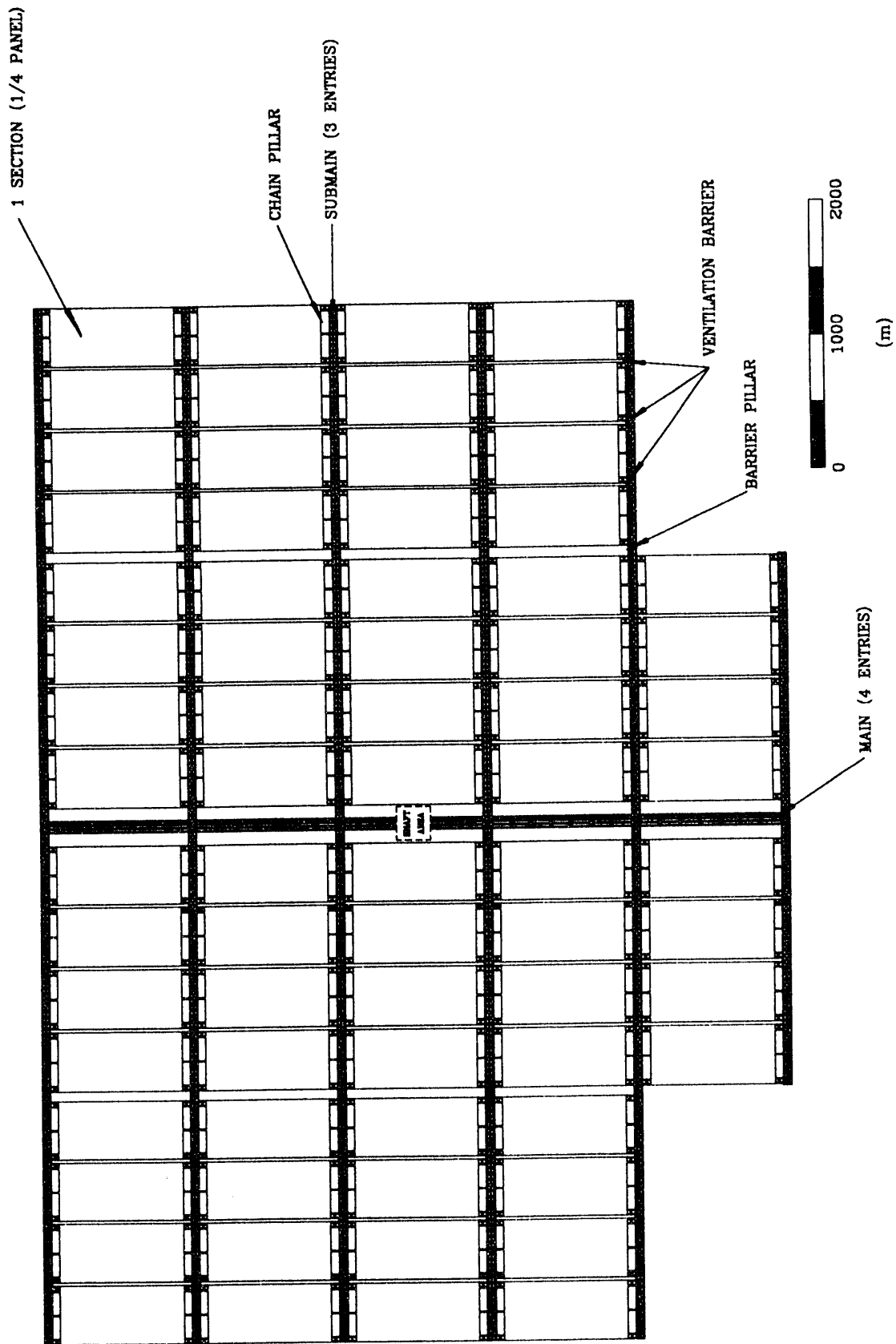

Figure 33. Layout of the Panels

All preproduction development of transportation drifts and stopes are carried out by two mechanical miners, except for the development work done by the contractor. A bendable snake conveyor or an extendable stope conveyor transports the excavated oil shale to the main conveyor and then to the raise connected to the skip-loading pocket. When each stope development is completed, a raise (3.0 m in diameter) is raisebored between the bottom of the stope (loading trough) and the top of the stope (overcut). This raise is used as a slot for production blasting. For estimation of the completion time and total cost for each preproduction task on the overcut, see Appendix A.

Undercut Preproduction for Large-Hole Stopping

The development of the undercut starts when the production shaft and the service shaft are completed. A contractor develops 500 m of the transportation drifts on the undercut. The rest of the undercut preproduction is carried out by the mine's own personnel.

Transportation drifts are selected as 6 m wide and 5 m high. Loading trough drifts and loading crosscuts are chosen to be 5 by 5 m. All drift development is carried out by one mechanical miner. All excavated areas are rock bolted, except for the trough drifts, in a 1.5- by 1.5-m pattern with 2.5-m-long resin-grouted bolts. A bendable snake conveyor behind the mechanical miner transports the excavated oil shale to the main conveyor and then to the skip-loading pocket.

The loading trough is excavated using conventional drilling and blasting. Holes are drilled with a large fan-drilling rig and charged with ANFO. A continuous loader loads the swell of the blasted oil shale on to a feeder breaker. The feeder breaker reduces the fragmentation size of the oil shale down to 10 to 20 cm and loads it onto a bendable belt conveyor, which transports it to the skip-loading pocket.

One mining block (eight loading troughs) is developed as preproduction. For an estimation of the completion time and the total cost for each preproduction task on the undercut, see Appendix A.

Mains and Panel Preproduction for Room and Pillar

The development of the mains and submains starts as soon as the production and service shaft are completed. A contractor develops 1000 m of the four-entry main from the shaft pillar. The rest of the preproduction development is carried out by the mine's own personnel. A total of four mining sections (one panel), mains, and submains for the first panel are developed as preproduction. The mains are 10 m wide and 8 m high. The pillars in the main are 135 m long and 16 m wide, whereas the pillars in the submains are 33 m long and 16 m wide. All excavated areas (walls and roof) are rock bolted in a 1.5- by 1.5-m pattern with 2.5-m-long resin grouted bolts. All preproduction drilling of mains, submains, and panels are carried out by rotary drill jumbos. The excavated oil shale is loaded by front-end loaders onto trucks and hauled to the crushing station located within the shaft pillar. The oil shale is crushed down to an average size of 10 to 20 cm before being transported to the skip-loading pocket. For estimation of completion times and total cost for each preproduction task, see Appendix B.

Ancillary Facilities

Facilities necessary for full production include a maintenance and supply shop, lunch room, lamp house, sanitary facilities, and two explosive magazines. The construction work is carried out by contractors. It starts when the service shaft is completed. It finishes during the last month of preproduction for large-hole stoping and during month 60 of preproduction for room and pillar.

Labor Requirements

The labor requirements for preproduction development are listed in Table 7. For the labor cost during preproduction, it is assumed that two shifts, 22 days a month are worked for all personnel for all of the large-hole stoping method and the room and pillar method until the first section is developed. After that (month 61), three shifts per day are worked (four shift crews, each working 42-hr/wk; see Appendix B). Table 7 also shows when the personnel were hired (month from the start of preproduction).

Equipment Requirements

Equipment requirements for the preproduction development are listed in Table 8.

Ventilation, Air, and Water Consumption

During preproduction, the required ventilation is estimated to be one-tenth of the ventilation requirement at full production (4000 m³/min for large-hole stoping; 13,5000 m³/min for room and pillar). The operating cost for air, water supply, and drainage is neglected during the preproduction.

Installation of Air, Water, and Electricity Systems

The installation of an electrical system, compressed air system, and water supply system is assumed to take place during the last six months of large-hole stoping preproduction and during months 56-60 of room and pillar preproduction.

Crushing Station

The construction of a crushing station for the room and pillar method is assumed to start as soon as the service shaft is completed. The crushing station is assumed completed by month 47. For estimation of construction costs, see Appendix B.

Table 7. Preproduction Labor List

| Type of Personnel | Large-Hole Stopping | | | | Room and Pillar | | | |
|----------------------------|---------------------|-------|-----------|----------|-----------------|-----------|--|--|
| | No. | Month | Salary | No. | Month | Salary | | |
| Mine Supervisor | 1 | 1 | \$6000/mo | 1 | 1 | \$6000/mo | | |
| Mine Production Engineers | 2 | 1 | 3900/mo | 2,2 | 1,61 | 3900/mo | | |
| Foreman (development) | 2 | 29 | 3900/mo | 2,2 | 28,61 | 3900/mo | | |
| Mine Surveyors | 4 | 29 | 3100/mo | 4 | 28 | 3100/mo | | |
| Mechanical Miner Operators | 10 | 29 | 21.30/hr | | | | | |
| Mechanical Miner Helper | 10 | 29 | 19.95/hr | | | | | |
| Conveyor Belt Operator | 10 | 29 | 19.95/hr | | | | | |
| Roof Bolters | 4 | 29 | 21.30/hr | 8,10,42 | 28,41,61 | 21.30/hr | | |
| Drill Jumbo Operator | | | | | | | | |
| Fan | 4 | 29 | 21.30/hr | | | | | |
| Rotary | | | | | | | | |
| Percussion | | | | | | | | |
| Raise Borer Operator | 6 | 36 | 21.30/hr | 2,2 | 28,61 | 21.30/hr | | |
| Drillers (ITH) | 4 | 43 | 21.30/hr | 4,4 | 28,61 | 21.30/hr | | |
| Blasting Team | 8 | 43 | 19.95/hr | | | | | |
| Continuous Loader Operator | 2 | 29 | 21.30/hr | 8,4 | 28,61 | 19.95/hr | | |
| Continuous Loader Helper | 2 | 29 | 19.95/hr | | | | | |
| Electricity Team | 6 | 29 | 18.30/hr | 6,6 | 43,61 | 18.30/hr | | |
| Mechanic's Equipment | 10 | 29 | 18.30/hr | 20,20 | 28,61 | 18.30/hr | | |
| Machinist Hoist | 4 | 29 | 18.30/hr | 4,4 | 28,61 | 18.30/hr | | |
| Hoist Operator | 2 | 29 | 15.90/hr | 2,2 | 28,61 | 15.90/hr | | |
| Scaler | | | | 4,8 | 28,61 | 21.30/hr | | |
| Truck Drivers | | | | 10,12,18 | 28,41,61 | 19.95/hr | | |
| Crushing Station Operator | | | | 2,2 | 46,61 | 18.30/hr | | |
| LHD Operators | | | | 6,6,12 | 28,41,61 | 21.30/hr | | |

Table 8. Preproduction Equipment List

| Equipment Type | Large-Hole Stoping | | Room and Pillar | |
|--------------------------------|--------------------|----------------|--------------------|----------------|
| | Total No. Required | Unit Cost (\$) | Total No. Required | Unit Cost (\$) |
| Mechanical Miners | 3 | 1,250,000 | | |
| ITH Drills | 2 | 205,100 | | |
| Continuous Loader | 1 | 383,900 | | |
| Feeder Breakers | 1 | 500,000 | | |
| Drill Jumbo | | | | |
| Fan | 2 | 288,100 | | |
| Rotary | | | 1 | 448,000 |
| Percussion | | | 2 | 390,000 |
| Conveyor Belts | --- | 2,182,000 | | |
| Raise Borers | 2 | 1,469,000 | | |
| Service Trucks | 1 | 61,900 | 1 | 61,900 |
| Roof Bolters | 2 | 518,000 | 3,5 | 518,000 |
| ANFO Loading Truck | 1 | 81,500 | 2 | 81,500 |
| Lube and Fuel Truck | 1 | 81,500 | 1 | 81,500 |
| Scissors Lift Truck | 1 | 70,600 | 2 | 70,600 |
| Trucks (CAT D550B) 50 ton m 28 | | | 4 | 385,000 |
| Trucks (CAT D550B) 50 ton | | | 6 | 385,000 |
| LHD (CAT 998B) m 28 | | | 2 | 290,000 |
| LHD (CAT 988B) m 41 | | | 3 | 290,000 |
| High-Capacity ANFO Loader | | | 1 | 400,000 |
| Scissors Lift Truck | | | 2 | 70,600 |
| Scaler Truck | | | 2 | 200,000 |
| Crusher Station Equipment | | | --- | 1,890,600 |

Time Table

The time table for large-hole stopping preproduction tasks is shown in Figure 34. The time table for room and pillar tasks is shown in Figure 35. The construction time for each task is listed in Appendices A and B.

Production

During full production of the large-hole stopping method, 75,000 tpd is mined. The stopping operation contributes 61,500 tpd, and the developing operation contributes an additional 13,500 tpd.

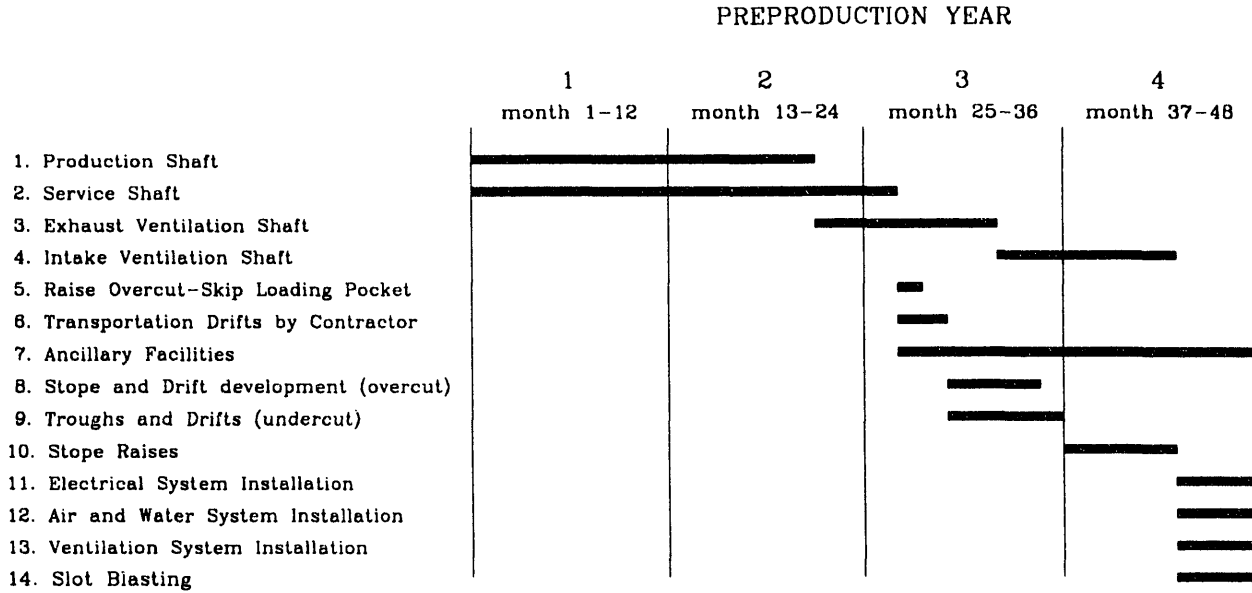

Figure 34. Time Table for Large-Hole Stopping Preproduction

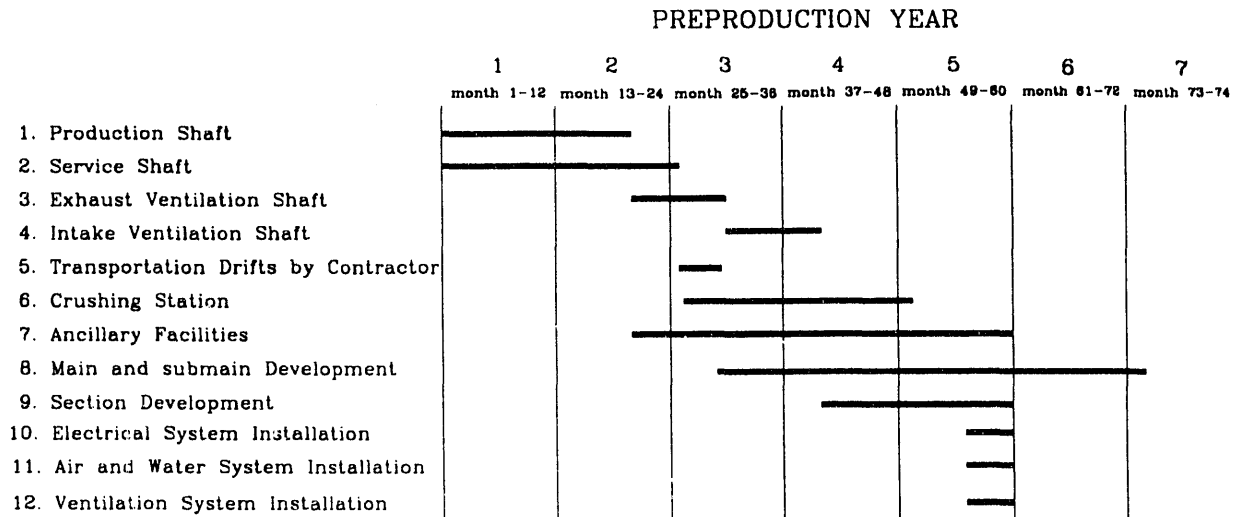

Figure 35. Time Table for Room and Pillar Preproduction

For the room and pillar method, full production (75,000 tpd) is achieved in month 74. The benching operation contributes 40,800 tpd, and the development operation contributes an additional 34,200 tpd.

Development for Large-Hole Stopping

Three mechanical miners are assumed to be used for the development of the overcut, and an additional two are used for development of the undercut. Each miner has an estimated production rate of 730 tons of oil shale per shift. All material excavated with the mechanical miners is conveyed without additional crushing to the skip-loading pocket for hoisting up to the surface. On the overcut, two mechanical miners with extendable stope conveyors are used for development of the stopes. The extendable stope conveyors are connected to the main conveyor (stope gather conveyor) in the transportation drift (Figure 36). One mechanical miner is used for development of the transportation drifts. A 140-m-long bendable snake conveyor behind the mechanical miner transports the material to the main conveyor. On the undercut, a 200-m-long bendable snake conveyor behind each mechanical miner transports the mined material to the main conveyor (Figure 37).

Three fully automated rock bolting machines are required (two on the overcut and one on the undercut); each is capable of bolting 80 bolts per shift. All walls and roofs are assumed rock bolted in a 1.5- by 1.5-m pattern with 2.5-m-long resin-grouted bolts. Two fan-drilling jumbos are used to drill the loading troughs. The layout for the blasting round is included in Appendix A. Five raise-boring machines and two ITH drills are required for development of the slot in each stope.

Production Drilling and Blasting for Large-Hole Stopping

ITH drills are used for production drilling. Twelve drills are required for full production, of which two are used for the slot drilling. The hole diameter is selected as 200 mm for the production drill holes and 152 mm for the slot holes. The wall holes of the stopes are reduced in diameter by placing a 100-mm plastic pipe in the 200-mm holes before charging and blasting. A total number of 159 holes, 79 m long, are drilled for each stope. The drill patterns for the stope and the slot are included in Appendix A.

Loading and Hauling for Large-Hole Stopping

Six continuous loaders and feeder breakers are estimated to be required for a stope production of 61,500 tpd. The continuous loaders load the rubblized material from the loading trough into the feeder breaker, which reduces the size down to 10 to 20 cm. The feeder breaker transports the crushed material onto one of the four extendable stope conveyors, placed in each loading drift in a mining block, on the undercut. The four stope conveyors transport the mined oil shale to a main conveyor (stope gather conveyor), placed in the transportation drift, for transportation to the skip-loading pocket (Figure 38). The main conveyor is assumed extended yearly or every second year, as development and production progress. For specifications of the conveyors chosen, see Table 9.

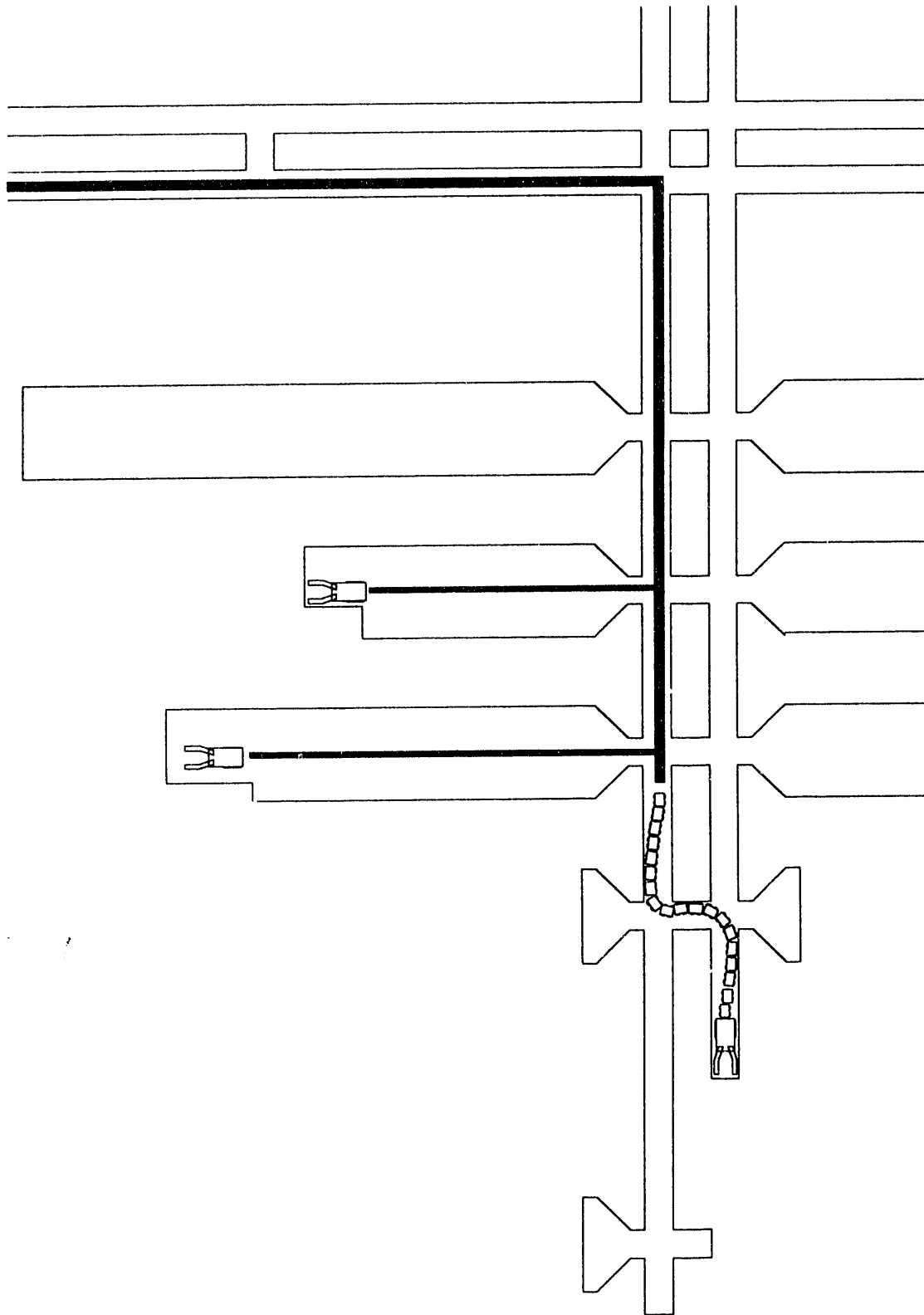

Figure 36. Stope and Transportation Drift Development (Overcut)

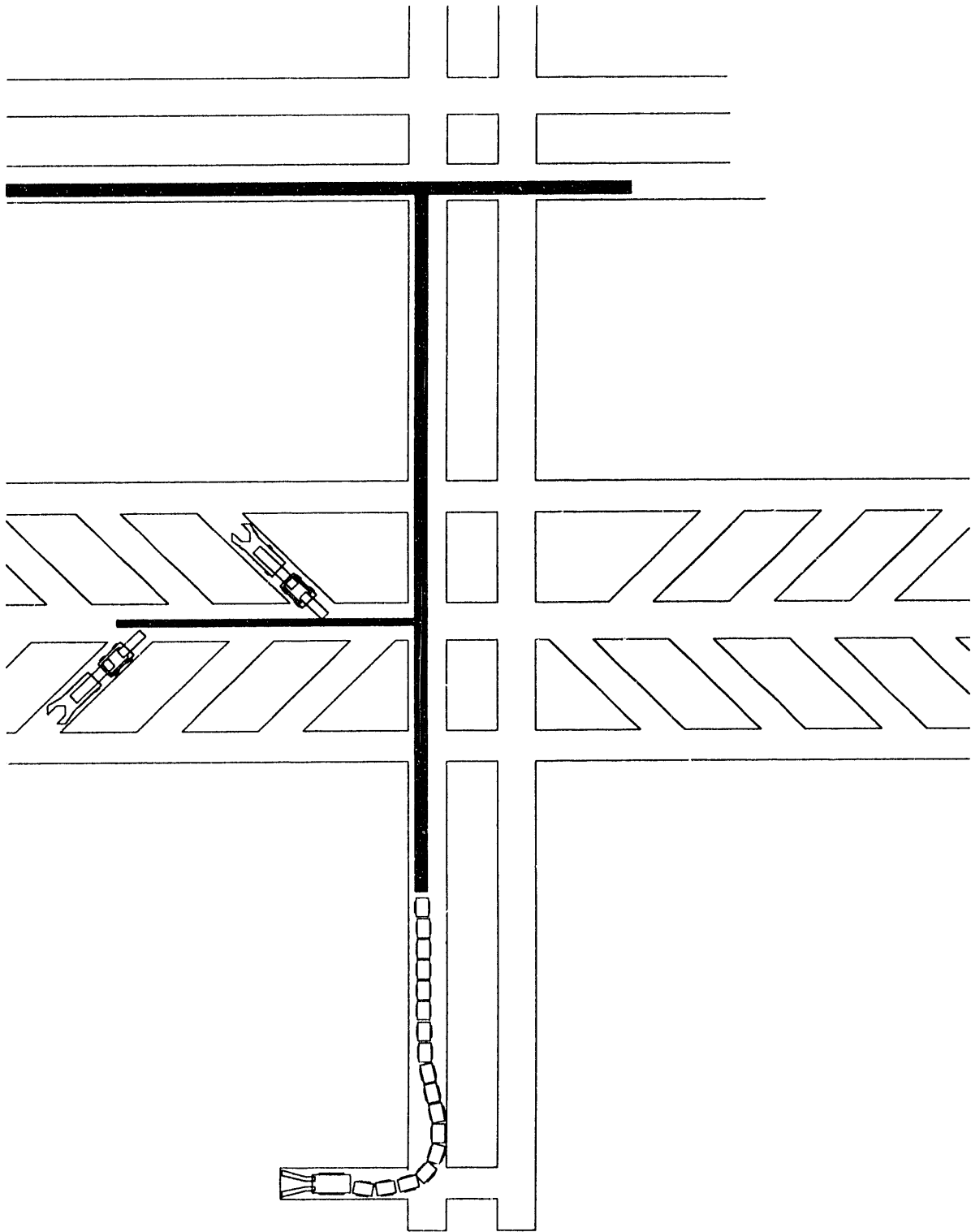

Figure 37. Undercut Development

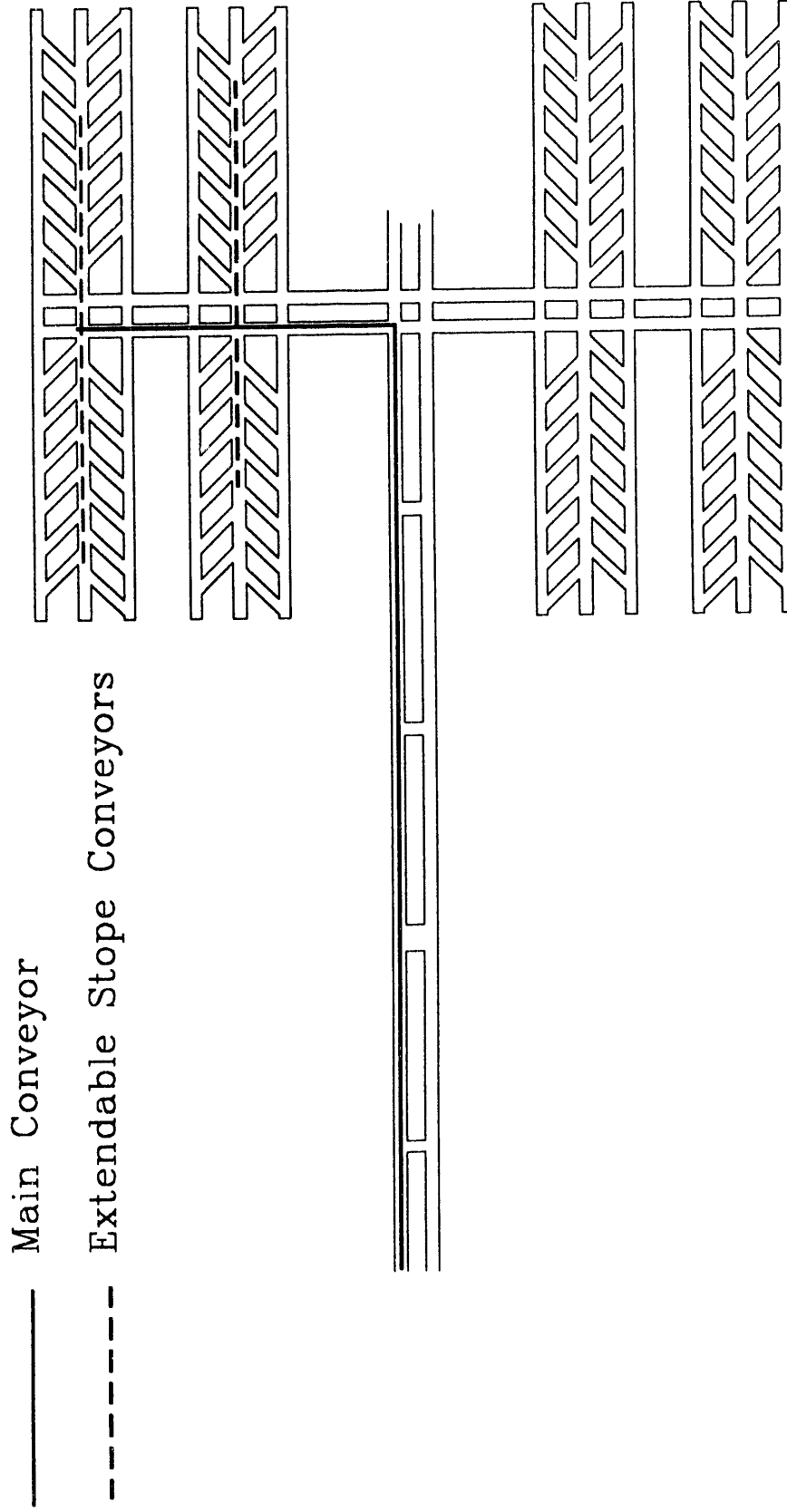

Figure 38. Stope Conveyors and Main Conveyors on the Undercut

Table 9. Belt Conveyors

| | Type and no. | Ave. Length | Width (m) | Belt Speed (m/s) | Max Capacity (tph) | Average Capacity (tph) |
|----|--------------------|-------------|-----------|------------------|--------------------|------------------------|
| UC | Main (1) | 1400 m | 1.83 | 3.0 | 6700 | 2900 |
| | Main (1) | 470 m | 1.83 | 3.0 | 6700 | 2900 |
| | Extend. Stope (4) | 70 m | 1.07 | 3.0 | 2160 | 700 |
| | Bendable Snake (2) | 200 m | 0.76 | 2.0 | 700 | 83 |
| OC | Main (1) | 1400 m | 0.76 | 2.0 | 700 | 83 |
| | Main (1) | 470 m | 0.76 | 2.0 | 700 | 83 |
| | Extend. Stope (2) | 70 m | 0.76 | 2.0 | 700 | 83 |
| | Bendable Snake (1) | 140 m | 0.76 | 2.0 | 700 | 83 |

Development for Room and Pillar

Two dual-boom rotary-drill jumbos are used for the development drilling of the heading. About 14 rounds per day (30,800 tpd) are scheduled. The hole diameter is selected as 114 mm. A dual-boom percussion-drill jumbo is used for the development drilling of the mains and submains. A hole diameter of 57 mm is used for the percussion drill. About four rounds are drilled per day. The drilled rounds for both the heading and mains are charged with ANFO and blasted at lunch breaks or shift change. The material excavated is loaded by CAT 988B loaders onto 50-ton trucks (CAT D550B) and hauled to the crushing station. After crushing of the oil shale down to a size of about 10 to 20 centimeters, the oil shale is transported to the skiploading pocket for hoisting up to the surface. All excavated areas (roof and walls) are scaled and rock bolted in a 1.5- by 1.5-m pattern with 2.5-m-long resin-grouted bolts. Fully automated rock bolting machines, each capable of bolting 80 bolts per shift are used.

Production Drilling and Blasting for Room and Pillar

Crawler ITH drills are used for the production drilling. Ten drills are required for full production. The hole diameter is 114 mm, and the burden and spacing are 2.8 m and 3.6 m, respectively. Each hole is 10 m long. The blasting layouts are included in Appendix B.

Loading and Hauling for Room and Pillar

Three CAT 992C front end loaders are used for the production loading. They load the blasted oil shale onto Cat D550B trucks for transportation to the crushing station.

Labor Requirements

The underground labor required for full production for both methods is listed in Table 10. A total of 457 employees is required for large-hole stoping, and a total of 529 employees is required for room and pillar. Four shift crews are being used, each crew is assumed to work 42 hours per week. Fringe benefits and burden are assumed to be included in the salaries given in Table 10. The calculated productivity for large-hole stoping is 164 tons per employee shift. The calculated productivity for room and pillar is 142 tons per employee shift.

Equipment Requirements

The equipment required for full production for both methods is listed in Table 11. This table includes the equipment purchased during the production, the additional equipment required for full production, and the total number required for full production. Note that the sum of the equipment purchased during the preproduction and the additional number required for full production start equal the total number required for full production. The life expectancy for the equipment in Table 11 has been estimated at 20 years for the conveyor belts, feeder breakers, backfill slurry pumps, mechanical miners, and the crushing station. For the remaining equipment, a life expectancy of 10 years is assumed.

Ventilation

The estimated ventilation requirement for large-hole stoping is 21,000 m³/min for the overcut and 14,000 m³/min for the undercut. The estimated ventilation requirement for room and pillar is 135,000 m³/min for the mine. The required ventilation has been estimated assuming: (1) 2.83 m³/min required for every diesel hp underground, (2) 0.1 m/s stope ventilation velocity, (3) 0.3 m/s minimum airway velocity for room and pillar, (4) 0.3 m/s minimum airway velocity on the undercut, (5) 6000 m³/min for shop and shaft pillar area, and (6) 25% (large-hole stoping) and 10% (room and pillar) for leaks and losses.

The large-hole stoping method uses a two-entry ventilation system, with one intake and one return airway. The room and pillar method uses a four-entry ventilation system, with two intake and two return airways. The ventilation intake shafts and exhaust shafts are located within the shaft pillar area. Ancillary fans and tubing are used, if necessary, for ventilating the stopes and the panels during development. Used air is routed directly to the return airway. The conveyor haulage is placed in the return airway. Stoppings are used between intake and return airways. Backfilled mining blocks and mined panels are closed off for ventilation.

Table 10. Underground Labor List

| Type of Personnel | <u>Large-Hole Stopping</u> | | <u>Room and Pillar</u> | |
|-----------------------------------|----------------------------|-----------|------------------------|-----------|
| | No. | Salary | No. | Salary |
| Mine Supervisor | 1 | \$6000/mo | 1 | \$6000/mo |
| Mine Production Engineers | 6 | 3900/mo | 6 | 3900/mo |
| Foreman electrical | 4 | 3900/mo | 4 | 3900/mo |
| Foreman mechanical | 4 | 3900/mo | 4 | 3900/mo |
| Foreman ventilation + air | 4 | 3900/mo | 4 | 3900/mo |
| Foreman production | 4 | 3900/mo | 4 | 3900/mo |
| Foreman development | 4 | 3900/mo | 4 | 3900/mo |
| Mine Surveyors | 6 | 3100/mo | 6 | 3100/mo |
| LHD Operators (CAT 988B) | | | 24 | 21.30/hr |
| LHD Operators (CAT 992C) | | | 16 | 21.30/hr |
| Truck drivers (CAT D550B) | | | 136 | 19.95/hr |
| Roof Bolters | 12 | 21.30/hr | 60 | 21.30/hr |
| Drill Jumbo Operator | | | | |
| Fan | 8 | 21.30/hr | | |
| Rotary | | | 8 | 21.30/hr |
| Percussion | | | 4 | 21.30/hr |
| Blasting Team | 24 | 19.95/hr | 24 | 19.95/hr |
| Scaler | | | 12 | 21.30/hr |
| Crushing Station Operator | | | 4 | 18.30/hr |
| Ventilation, air, water | 16 | 18.30/hr | 16 | 18.30/hr |
| Electricity Team | 16 | 18.30/hr | 16 | 18.30/hr |
| Water Truck Operators | 12 | 19.95/hr | 12 | 19.95/hr |
| Service Personnel (fuel and lube) | 12 | 18.30/hr | 12 | 18.30/hr |
| Mechanics equipment + shop | 40 | 18.30/hr | 80 | 18.30/hr |
| Machinist Hoist | 8 | 18.30/hr | 8 | 18.30/hr |
| Hoist Operator | 4 | 15.90/hr | 4 | 15.90/hr |
| Supply Shop | 16 | 15.90/hr | 16 | 15.90/hr |
| Mechanical Miner Operators | 24 | 21.30/hr | | |
| Mechanical Miner Helper | 24 | 19.95/hr | | |
| Conveyor Belt Operator | 40 | 19.95/hr | | |
| Raise Borer Operator | 40 | 21.30/hr | | |
| Drillers (ITH) | 52 | 21.30/hr | | |
| Backfill Team | 20 | 19.95/hr | | |
| Continuous Loader Operator | 28 | 21.30/hr | | |
| Continuous Loader Helper | 28 | 19.95/hr | | |

Table 11. Equipment List

| | Large-Hole Stopping | | | | Room and Pillar | | | |
|---------------------------|------------------------------------|-----------------------------------|-----------------------------------|--------------------|------------------------------------|--|-----------------------------------|--------------------|
| | No. Purchased During Preproduction | No. Required For Full Prod. Start | Total No. Required for Full Prod. | Unit Cost (\$1000) | No. Purchased During Preproduction | Additional No. Required For Full Prod. Start | Total No. Required for Full Prod. | Unit Cost (\$1000) |
| Mechanical Miners | 3 | 2 | 5 | 1,250.0 | 0 | 10 | 10 | 152.0 |
| ITH Drills | 2 | 10 | 12 | 205.1 | | | | |
| Continuous Loaders | 1 | 5 | 6 | 383.9 | | | | |
| Feeder Breakers | 1 | 5 | 6 | 500.0 | | | | |
| Drill: fan | 2 | 0 | 2 | 288.1 | 2 | 0 | 0 | 390.0 |
| percussion rotary | | | | | 2 | 0 | 0 | 448.0 |
| ANFO Loading Truck | 1 | 0 | 1 | 81.5 | 2 | 0 | 2 | 81.5 |
| Slurry Loading Trucks | 3 | 3 | 3 | 400.0 | | | | |
| High Capacity ANFO Loader | | | | | 1 | 1 | 2 | 400.0 |
| Conveyor Belts | | | | 14,609.0 | | | | |
| Raise Borers | 2 | 3 | 5 | 1,469.0 | | | | |
| Roof Bolters | 2 | 1 | 3 | 518.0 | 10 | 4 | 14 | 518.0 |
| Scaler | | | | | 2 | 1 | 3 | 200.0 |
| Trucks Cat 550B | | | | | 10 | 24 | 34 | 385.0 |
| LHD 988B | | | | | 5 | 0 | 0 | 290.0 |
| 992B | | | | | 0 | 3 | 3 | 410.0 |
| Service Trucks | 1 | 2 | 3 | 61.9 | 1 | 2 | 3 | 61.9 |
| Water Truck | 0 | 3 | 3 | 61.1 | 0 | 3 | 3 | 61.1 |
| Lube and Fuel Truck | 1 | 2 | 3 | 81.5 | 1 | 2 | 3 | 81.5 |
| Scissors Lift Truck | 1 | 2 | 3 | 70.6 | 2 | 2 | 4 | 70.6 |
| Manning Trucks | 0 | 3 | 3 | 70.6 | 0 | 3 | 3 | 70.6 |
| Backfill Slurry Pump | 0 | 4 | 4 | 15.7 | | | | |
| Ambulance | 0 | 2 | 2 | 80.0 | 0 | 2 | 2 | 80.0 |
| Equipment for Shop | | | | 1,300.0 | | | | 1,300.0 |
| Crusher Station Equipment | | | | | | | | 1,890.6 |

Water and Compressed Air

The estimated supply of water for the operation is 2,000 m³/day. For drainage, 10,000 m³ will be pumped every day. The estimated compressed air requirement is 1,150 m³/min for large-hole stoping and 890 m³/min for room and pillar.

Mining Costs

The mining costs in this study have been estimated using the U.S. Bureau of Mines Cost Estimating System Handbook (1987), the Updated Scott-Ortech Cottonwood Wash Mine Feasibility Study (Synfuels Engineering, 1982), Mining Cost Service (Western Mine Engineering, 1988), and Underground Mining Methods Handbook (1982). The costs are separated into preproduction cost, capital investment cost, and operating cost. Costs for taxes, insurance, and royalties are not included in the study. Neither has the cost for surface facilities, surface labor, and surface operating costs been included in the study. All costs are 1990 costs.

Preproduction Cost

The preproduction cost includes all costs (capital investment, supply, and operating costs) during the preproduction period. The preproduction cost for large-hole stoping is summarized in Table 12. The preproduction cost for room and pillar is summarized in Table 13. Total preproduction cost for both methods is listed in Table 14. The total preproduction cost of large-hole stoping amounts to \$117,828,000, including interest of 9 percent during a preproduction period of 48 months. The total preproduction cost of room and pillar amounts to \$198,475,000, including interest of 9 percent during a preproduction of 74 months. In the room and pillar method, the preproduction development is 47 percent of the total production, compared with only 18 percent for large-hole stoping. The estimates of the preproduction cost items are listed in Appendices A and B.

Capital Investment Cost

The capital investment cost is summarized in Table 15. The total cost for large-hole stoping amounts to \$178,704,000; the total cost for room and pillar is \$251,707,000. The capital investment cost consists of equipment investment cost and the preproduction cost for bringing the mine into full production. Ten percent for contingencies, working capital cost, and the interest cost of preproduction were also included (48 months for large-hole stoping, 74 months for room and pillar). The working capital cost was estimated for three months full production. For the interest cost, an annual interest rate of 9 percent was assumed.

Operating Cost

The estimated operating cost of the mine using large-hole stoping is \$ 3.27 per ton of oil shale mined; \$3.64/ton is estimated for the room and pillar method. The operating cost consists of supplies (explosive, fuel, rock bolts, compressed air, etc.), labor and equipment operating cost, indirect cost, depreciation costs, and average annual interest cost. The operating cost for the two methods is summarized in Tables 16 and 17, respectively.

Table 12. Preproduction Cost Per Year for Large-Hole Stopping (\$1000)

| | Year 1 | Year 2 | Year 3 | Year 4 |
|--|-----------|-----------|-----------|-----------|
| Equipment | | | 11,662 | 411 |
| Labor | 166 | 166 | 2,190 | 3,615 |
| Shaft Sinking - production | 16,197 | 12,148 | | |
| service | 8,235 | 8,235 | 1,373 | |
| ventilation exhaust | | | 12,606 | |
| ventilation intake | | | 6,552 | 655 |
| Raise Overcut - Skiploading Pocket | | | 49 | |
| Transport Drift by Contractors UC & OC | | | 992 | |
| Stope Drift Development - Over cut | | | 653 | |
| Transport & Loading Drifts + Crosscut UC | | | 526 | |
| Trough UC | | | 256 | |
| Hoisting Operating | | | 164 | 115 |
| Ventilation Operating (30.5 days/month) | | | 30 | 40 |
| Ancillary Facilities | | | 1,287 | 1,546 |
| Ventilation Capital | | | | 1,197 |
| Compressed Air Capital | | | | 1,410 |
| Electrical Capital | | | | 1,497 |
| Water & Drainage Capital | | | | 972 |
| Fuel | | | 22 | 37 |
| Stope Raises (8) | | | | 248 |
| Slot Blasting (8) | | | | 195 |
| Total | \$24,598 | \$20,549 | \$38,362 | \$11,938 |

An indirect cost of 5 percent of the direct costs was added to account for corporate management, personnel training, travel expenses, and overtime for lost production. The depreciation cost was calculated assuming straight-line depreciation according to the depreciation schedules in Appendices A and B. Preproduction development costs were depreciated for the mine life (30 years). The average annual interest cost was calculated using equation 32, where A is the average annual interest cost, C is the capital investment cost, S is the salvage value, and L is the depreciable life. No salvage values were used. An annual interest rate (i) of 9 percent was used.

$$A = (C-S) \left(\frac{i}{2} \right) \left(\frac{L+1}{L} \right) \quad (32)$$

Table 13. Preproduction Cost Per Year for Room and Pillar (\$1000)

| Preproduction Cost | Year 1 | Year 2 | Year 3 | Year 4 | Year 5 | Year 6 | Year 7* |
|--------------------------------|-----------------|-----------------|-----------------|-----------------|-----------------|-----------------|----------------|
| Equipment | | | 7,191 | 6,619 | | 1,484 | |
| Labor | | 166 | 2,611 | 4,316 | 4,746 | 10,383 | 1,730 |
| Shaft Sinking | 166 | | | | | | |
| production | 16,674 | 11,116 | | | | | |
| service | 8,056 | 8,056 | 675 | | | | |
| ventilation exhaust | | 4,598 | 6,897 | | | | |
| ventilation intake | | | 6,897 | 4,598 | | | |
| Crushing Station | | | 350 | 349 | | | |
| Transport Drift by Contractors | | 1,680 | | | | | |
| Main and Submain Development | | 1,380 | 2,069 | 2,069 | | | |
| Section Development | | | | 1,794 | 2,691 | 11,826 | 1,971 |
| Hoisting Operating | | | 443 | 507 | 507 | 2,332 | 390 |
| Ventilation Operating | | | 121 | 132 | 132 | 138 | 23 |
| Ancillary Facilities | | 708 | 1,063 | 1,062 | | | |
| Ventilation Capital | | | 6,829 | | | | |
| Compressed Air Capital | | | | 1,176 | | | |
| Electrical Capital | | | | 1,239 | | | |
| Water & Drainage Capital | | | | 972 | | | |
| Fuel | | | 37 | 64 | 64 | 64 | 11 |
| Total | \$24,896 | \$23,936 | \$28,990 | \$28,340 | \$14,658 | \$26,227 | \$4,125 |

Table 14. Total Preproduction Cost*

| | Large-Hole Stopping | Room and Pillar |
|--------------------|----------------------|---------------------|
| Preproduction cost | \$ 95,447,000 | \$151,172,000 |
| Interest (9%) | <u>\$ 22,381,000</u> | <u>\$47,303,000</u> |
| Total | \$ 117,828,000 | \$198,475,000 |

* Preproduction time is 48 months for large-hole stopping and 74 months for room and pillar.

Table 15. Capital Investment Cost (\$1000)

| Item | Large-Hole Stopping | Room and Pillar |
|--|---------------------|---------------------|
| Preproduction Development ^a | 83,374 | 135,878 |
| Subtotal | 125,314 | 168,118 |
| Contingencies (10%) | 12,531 | 16,812 |
| Working Capital ^b | 18,478 | 19,474 |
| Interest during preproduction | 22,381 ^c | 47,303 ^d |
| Total Capital Investment Cost | 178,704 | 251,707 |

^a preproduction development does not include equipment investment and interest

^b 3 months at full production

^c 48 months

^d 74 months

Table 16. Operating Cost for Large-Hole Stopping

| Item | Cost per day (\$) | Cost per ton (\$) |
|-------------------------------------|----------------------|----------------------|
| Labor | 55,000 | 0.73 |
| Production | | |
| Drilling | 12,960 | 0.17 |
| Blasting | 29,700 | 0.40 |
| Loading + Crushing | 8,400 | 0.11 |
| Conveying | 2,830 | 0.04 |
| Backfill | 26,000 | 0.35 |
| Development | | |
| Mechanical Mining | 12,200 | 0.16 |
| Bolting | 11,050 | 0.15 |
| Conveying | 1,100 | 0.01 |
| Raiseboring | 4,600 | 0.06 |
| Troughs | 4,700 | 0.06 |
| Compressed Air | 3,950 | 0.05 |
| Ventilation | 2,740 | 0.04 |
| Water and Drainage | 1,600 | 0.02 |
| Hoisting | 14,900 | 0.20 |
| Fuel Consumption | 600 | 0.01 |
| Subtotal | 192,330 | 2.56 |
| Indirect Cost (5 % of direct costs) | 9,616 | 0.13 |
| Depreciation Cost | 18,637 | 0.25 |
| Interest Cost | 24,580 | 0.33 |
| Total Cost (75,000 ton mined) | 245,163 | 3.27 |

Table 17. Operating Cost for Room and Pillar

| Item | Cost per day (\$) | Cost per ton (\$) |
|-------------------------------------|-------------------|-------------------|
| Labor | 63,200 | 0.84 |
| Production | | |
| Drilling | 7,700 | 0.10 |
| Blasting | 9,140 | 0.12 |
| Loading | 2,200 | 0.03 |
| Hauling | 5,900 | 0.08 |
| Bolting | 6,600 | 0.09 |
| Development | | |
| Drilling (mains) | 1,140 | 0.02 |
| Drilling (heading) | 8,020 | 0.11 |
| Blasting (mains) | 1,720 | 0.02 |
| Blasting (heading) | 10,700 | 0.14 |
| Loading | 2,500 | 0.03 |
| Hauling | 5,500 | 0.07 |
| Bolting | 12,200 | 0.16 |
| Crushing cost | 1,800 | 0.02 |
| Surface Disposal of Spent Shale | 22,000 | 0.29 |
| Compressed air | 2,900 | 0.04 |
| Ventilation | 23,200 | 0.31 |
| Water and Drainage | 1,600 | 0.02 |
| Hoisting | 14,000 | 0.19 |
| Fuel Consumption | 680 | 0.01 |
| Subtotal | 202,700 | 2.70 |
| Indirect cost (5 % of direct costs) | 10,135 | 0.14 |
| Depreciation Cost | 26,389 | 0.35 |
| Interest Cost | 33,891 | 0.45 |
| Total Cost (75,000 ton mined) | 273,115 | 3.64 |

COMPARISON BETWEEN LARGE-HOLE STOPPING USING BUFFER BLASTING AND CONVENTIONAL ROOM AND PILLAR METHODS

Mining Costs

The operating cost, capital investment cost, and preproduction cost for the indicated daily tonnage mined and the estimated daily oil production are summarized in Table 18 for the comparison of room and pillar mining versus large-hole stopping.

Table 18. Economic Comparison

| | Large-Hole Stopping | Room and Pillar |
|-------------------------------|---------------------|------------------|
| Development time | 48 months | 74 months |
| Development tonnage | 808,000 ton | 23,138,000 ton |
| Capital investment | \$178,704,000 | \$251,707,000 |
| Preproduction cost | \$117,828,000 | \$198,475,000 |
| Operating cost per ton | | |
| Direct | \$2.69 | \$2.84 |
| Indirect | \$0.58 | \$0.80 |
| Total | \$3.27 per ton | \$3.64 per ton |
| Operating cost per barrel | \$7.62 | \$4.73 |
| Average grade | 79 L/ton | 142 L/ton |
| Tonnage mined | 75,000 | 75,000 |
| Oil production (95% recovery) | ~ 32,200 bbl/day | ~ 57,700 bbl/day |

The capital investment cost and the preproduction cost are higher for the room and pillar mine compared with the large-hole stopping mine. This is because of the longer preproduction period (74 months) and the higher specific development for the room and pillar mine.

The operating cost per ton for the large-hole stopping design (\$3.27) is lower than for the room and pillar design (\$3.64). However, the operating cost per barrel of oil is higher for the large-hole stopping design (\$7.62 compared with \$4.73 for the room and pillar design) because of the lower grade mined. It appears for a mine life of 30 years, that the room and pillar design is economically more feasible because a higher average grade is mined. However, for a shorter mine life, in the case with limited

reserves, the large-hole stoping method becomes more competitive because of the lower capital investment cost and shorter preproduction period.

To evaluate the effects of oil shale grade, capital investment cost, and operating cost on the feasibility of an oil shale project, a cash-flow analysis is necessary. In order to do a cash-flow analysis, the processing capital cost, processing operating cost, surface facilities cost, surface labor cost, and surface operating cost have to be included. This is, however, beyond the scope of this study.

Technical Characteristics

The technical characteristics of the two methods are summarized in Table 19. The technical comparison is similar to the work done by Cameron Engineers (1977). Table 20 summarizes the advantages and disadvantages of both methods.

Table 19. Technical Comparison

| Mining Method | Large-Hole Stopping | Room and Pillar |
|--|---|---------------------------|
| Development period | 48 months | 74 months |
| Development tonnage | 808,000 ton | 23,138,000 ton |
| Specific development | 18% | 47% |
| Labor requirements | 457 | 529 |
| Productivity | 164 ton/employee shift | 142 ton/employee shift |
| Mining selectivity | fair | good |
| Resource recovery | about 35% | about 19% |
| Mineable height on each level | up to 100 m | about 20 m |
| Subsidence potential | minimal | minimal |
| Health and safety | good | good |
| Possibility for production increase | good | fair |
| Loading and hauling | continuous loader and conveyor belts | LHD and trucks |
| Automation possibilities | excellent | good |

Table 20. Advantages and Disadvantages of the Two Mining Methods

| | Advantages | Disadvantages |
|--|---|---|
| Room and Pillar | <p>Selective; can mine thin sequences of oil shale</p> <p>Highly mechanized; high productivity</p> <p>Simple ventilation system</p> | <p>No underground disposal of spent shale</p> <p>Moderate development period</p> <p>Fair overall resource recovery</p> <p>High specific development</p> <p>Highly spread out mine</p> |
| Large-Hole Stopping with Buffer Blasting | <p>Highly mechanized; high productivity</p> <p>Underground disposal of spent shale</p> <p>High overall resource recovery</p> <p>Low preproduction development</p> | <p>High backfill cost</p> <p>Complex ventilation system</p> |

Development Time and Tonnage

The development time is the time required from initial shaft sinking until full production (75,000 tpd) is reached. The development tonnage is defined as the tonnage of oil shale that is mined during the preproduction period. A short development time is preferable to minimize interest costs during preproduction.

Specific Development

Specific development is the part of the daily production that is development. A low percentage is preferable because development is commonly more costly than production.

Productivity

Productivity is the tonnage mined per employee shift. Note that only the underground labor is considered in the study. High productivity is always preferable.

Mining Selectivity

Mining selectivity is defined as the ability to mine higher grade zones of oil shale (10-30 m thick). A ranking of fair, good, and excellent was made to differentiate grade zones.

Resource Recovery

The resource recovery is defined as the amount of recovered oil expressed as a percentage of the total oil in-place in the reserve. A 100-m thick oil shale seam was assumed from the Mahogany zone to the R6 zone. The grades were estimated from the Colony Oil Shale Project (Exxon, 1988).

Health and Safety Rank

A rank of low, normal, or high was arbitrarily assigned to health and safety considerations as shown in Table 21, taking into account the potential exposure of employees to roof fall, diesel fumes, noise, and dust.

Table 21. Health and Safety Ranking

| | Large-Hole Stoping | Room and Pillar |
|---------------|--------------------|-----------------|
| Roof Fall: | normal | normal |
| Diesel Fumes: | low | high |
| Noise: | normal | normal |
| Dust: | normal | normal |

Production Increase

The possibility of production increases over 75,000 tpd was ranked fair, good, or excellent for the two methods. The productivity may be easily increased for the large-hole stoping method because all unit operations are independent of each other.

For the room and pillar design, which uses rubber-tired loading and haulage, the possibility of increasing the productivity is more limited. A large number of trucks underground can result in long waiting lines and cause dispatch routing problems leading to a slow-down in production. The development operation is a cyclic operation where a machine breakdown immediately affects production.

Automation Possibilities

The automation possibilities for the two mining systems were given a ranking of excellent, good, or fair. Remote-controlled continuous loaders and continuous miners can make the already automated large-hole stoping method a truly automated mining system. For the room and pillar method, the use of remote-controlled trucks and loaders is feasible. However, frequent moves of equipment will make automation more difficult than for large-hole stoping.

CONCLUSIONS AND RECOMMENDATIONS

Conclusions

The results from the technical and economical comparison of the two mining methods indicate that the large-hole stoping method using some innovative fragmentation system has a lower operating cost per ton (\$3.27 per ton) compared with the room and pillar mine (\$3.64 per ton). However, because large-hole stoping mines a lower grade, the operating cost per barrel of oil is much higher (\$7.62 compared with \$4.73 for the room and pillar mine). It is therefore concluded, that the room and pillar method is economically more attractive for mining the deep oil shale beds in Colorado. However, the large-hole stoping design has a number of advantages in comparison with the room and pillar design:

1. Lower specific development. This leads to shorter preproduction period, lower preproduction cost, and accordingly lower interest cost during the preproduction.
2. Higher resource recovery. About 35 percent of the in-place shale oil is mined with the large-hole stoping method compared with 19 percent for the room and pillar method.
3. The mine used with the stoping method has the resources more concentrated that does the room and pillar mine. A highly spread out mine leads to added capital and operating costs for potential additional shaft complex or higher transportation costs.
4. Greater equipment utilization and greater automation possibilities imply enhanced production since the unit operations (drilling, blasting, loading) are relatively independent of each other.
5. Underground disposal of spent shale reduces the rock mechanics problems, surface subsidence, and surface disturbance. The room and pillar mine could also use backfilling. However, this procedure would be more difficult and, therefore, more costly. This would be added to the operating cost.

The room and pillar method has the advantage of selectively mining the rich sequences of oil shale. Another advantage is the simple ventilation system. It can also be concluded that for limited reserves, that the large-hole stoping method becomes more competitive because of lower capital investment cost, lower preproduction cost, and accordingly lower preproduction interest cost. However, the room and pillar method appears more economical, although the large hole stoping method has more desirable technical features.

Recommendations

For the technical and economical evaluation of the two mine designs, it is recommended that a cash-flow analysis be performed. A cash-flow analysis is necessary to evaluate the effect of these factors on the feasibility of an oil shale project: oil shale grade, capital investment cost, length of preproduction, and operating cost. In order to do a cash-flow analysis, the capital and operating processing cost, surface facility cost, surface labor cost, and surface operating cost have to be incorporated.

For the buffer blasting part, a few recommendations regarding problems encountered while conducting the blasting experiments can be useful for future model blasting experiments in concrete. If precast holes are to be used for the experiments, single-hole blasts in small blocks should be performed in order to determine burden for optimum fragmentation. When the burden is known for the explosive and charge used, the spacing is carefully chosen for the type of blasts that will be performed (i.e., instantaneous blasts or interhole delay blasts). When these parameters have been determined, larger concrete blocks may be cast for blasting toward a buffer of different swell factors.

Precast holes are not recommended. Problems with cracks developing along the line of holes perpendicular and parallel to the free face prevented achieving good fragmentation in all experiments. This problem may be partly eliminated by spacing the holes farther apart and by using an explosive with lower strain energy and slower expanding gas volume.

The commercial caps (for example, no. 8 strength cap) should be placed outside the hole so that they will not influence the fragmentation results. Commercial caps have too heavy of base charge of PETN for a model-scale experiment.

A different explosive than PETN should be used for blasting in concrete. PETN is an explosive with a rapid release of the expanding gases that splits the concrete instead of fragmenting it. An explosive with a relatively slow release of the expanding gases would be more efficient for fragmenting the concrete. Further investigations of the use of Iresplit-D as an alternative to PETN in model-scale experiments are suggested.

ACKNOWLEDGEMENTS

The authors express thanks and appreciations to the United States Department of Energy for funding of this work under Cooperative Agreement Number DE-FC21-86MC11076 as well as to Western Research Institute for funding under Subcontract Number 893002.

DISCLAIMER

Opinions in this report reflect opinions of the authors and are not necessarily opinions of Western Research Institute. Mention of specific brand names is for information only.

REFERENCES

- AECI. 1980. Ring Blasting, The Design of Ring Patterns. Explosives Today: A Technical Bulletin from AECI Explosives and Chemicals Ltd. Series 2, No.
- AECI. 1986. The Design of Surface Blasts. Explosives Today: A Technical Bulletin from AECI Explosives and Chemicals Ltd. Series 2, No. 41.
- Ash, R.E. 1968. Design of Surface blasts. Surface Mining, AIME New York. Ed. Pfleider. p. 385.
- Atlas Powder Co. 1987. Explosives and Rock Blasting. Maple Press and Co. p. 234.
- Brady, B. H. G.; Brown, E. T. 1985. Rock Mechanics for Underground Mining. Ed. G. Allen & Unwin Ltd., London.
- Cameron Engineers Inc. 1977. A Technical and Economic Study of Candidate Underground Mining Systems for Deep, Thick Oil Shale Deposits. Denver, Colorado. U.S. Bureau of Mines Open File Report 9-77.
- Clark, G. B. 1987. Principles of Rock Fragmentation. Publisher John Wiley and Sons. p. 431-449.
- Crookston, R. B.; Weiss, D. A.; Weakly, L. A. 1982. A First Look at Continuous Miners in Colorado Oil Shale. American Mining Congress International Mining Show, Las Vegas, Nevada. October 11-14.
- Cunningham, C. V. B. 1983. The Kuz-Ram Model for Prediction of Fragmentation From Blasting. First Int. Symp. on Rock fragmentation by Blasting. Luleå. Ed. R. Holmberg and A. Rustan. v. 1 p. 439.
- Cunningham, C. V. B. 1987. Fragmentation Estimations and the Kuz-Ram Model Four Years On. Second Int. Symp. on Rock Fragmentation by Blasting. Keystone, Colorado. v. 1 p. 475.
- DME Enterprises Inc. 1989. Equipment Specifications From DME Enterprises Inc, Saskatoon, Saskatchewan, Canada.
- DOE \ EIA, 1990. Annual Energy Review. U.S. Department of Energy.
- Dubynin, N. G. 1973. Blasting Problems Created by the Development of New Ore Mining Procedures. Soviet Mining Science. v. 9. p. 265-268.
- Ertec, 1981. Mahogany oil Shale Project. Review of Mechanical Excavators for Applicability to Oil Shale Mining. Report Prepared for Phillips Petroleum Company. Proj. No. 81-022.
- Exxon. 1982. Colony. The Colony Shale Oil Project. A Brochure From the Exxon Corporation.

- Exxon. 1988. Colony Shale Oil Project. A Brochure Received at a Visit at the Exxon Corporation in Grand Junction, Colorado.
- Field, J. E.; Ladegaard-Pedersen, A. 1971. The Importance of the Reflected Stress Wave in Rock Blasting. Int. Journ. of Rock Mech. and Mining Science. v. 8 p. 213-225.
- Hagan, T. N. 1977. Good Delay Timing-Prerequisite of Efficient Bench Blasts. Proc. Aust. Inst. Min. Metall. No. 263 p. 198-205.
- Hagan, T. N.; Just, G. D. 1974. Rock Breakage by Explosives, Theory, Practice and Optimization. Proceedings of the Int. Soc. of Rock Mechanics, Denver. p. 1349-1357.
- Hamrin, H. 1986. Guide to Underground Mining Methods and Applications. Atlas Copco, Stockholm, Sweden.
- Harris, C. C. 1968. The Application of Size Distribution Equation to Multi-Event Comminution Processes. Trans. Am. Inst. Mining, Metallurgical and Petroleum Eng. v. 241 p. 343-358.
- Hjelmberg, H. 1983. Some Ideas on How to Improve Calculations of the Fragment Size Distribution in Bench Blasting. First Int. Symp. on Rock Fragmentation by Blasting, Luleå. v. 2 p. 469-487.
- Holmberg, R. 1981. Optimum Blasting in Bedded and Jointed Oil Shale Formations. Final Report DOE, P.L. 92216, Laramie Energy Technology Center.
- Holmberg, R. 1982. Charge Calculations for Tunneling. Underground Mining Methods Handbook. Ed. W. A. Hustrulid. p. 1580-1589.
- Hustrulid, W.A.; Holmberg, R.; Pesce, E. 1984. Mining and Fragmentation Oil Shale Research. Mechanics of Oil Shale. Ed. K.P. Chong. Elsevier Applied Sc. Publisher. p. 457-521.
- Imenitov, V. R. 1970. Scientific and Technical Development of an Underground Mining Method Using Buffer Blasting. 6th Int. Mining Congr. Soviet Union. (Paper Translated into Swedish by LKAB).
- Kutter, H. K.; Fairhurst, C. 1971. On the Fracture Process in Blasting. Int. Journ. of Rock Mech. and Mining Science, v. 8 p. 188-201.
- Kutznetsov, V. M. 1973. The Mean Diameter of the Fragments Formed by Blasting of Rock. Soviet Mining Science. v. 9 p. 144-148.
- Langefors U.; Kihlström, B. 1978. The Modern Technique of Rock Blasting. Third Edition. Almqvist Wiksell, Stockholm.

- Larsson. 1973. Styckefallstutredning. Skånska Cementgjuteriet (In Swedish).
- Lilly, P. A. 1986. An Empirical Method of Assessing Rock Mass Blastability. The Aus. IMM. Large Open Pit Mining Conf.
- Lownds, C. M. 1983. Computer Modelling of Fragmentation From an Array of Shotholes. First Int. Symp. on Rock fragmentation by Blasting. Luleå. v. 2 p. 455-468.
- Markenzon, E. I. 1967. Mechanism of Blasting Without a Compensating Space. Soviet Mining Science. v. 3 p. 45-47.
- Norell, B. 1985. The Effect of the Delay Interval on Fragmentation. (In Swedish). Swedish Detonic Research Foundation (SveDeFo) DS 1985:1.
- Olsson, M. 1988. Blasting Toward Rubblized Materials. SveDeFo (In Swedish).
- Rustan, A. 1981. Parameters Influencing Fragmentation by Rock Blasting. Technical Report Luleå University of Technology. 1981:38T.
- Rustan, A. 1990. Blasting Against Fill in Rill Mining. G2000. Luleå University of Technology, Sweden.
- Rustan, A.; Shu Lin N. 1987. New Method to Test the Rock Breaking Properties of Explosives in Full Scale. Second Int. Symp. on Rock Fragmentation by Rock Blasting, Keystone, Colorado. p. 36-47.
- Shu Lin, N. 1988. New Hard Rock Fragmentation Formulae Based on Model and Full Scale Tests. Tekn. Lic. Thesis 1988:02L. Luleå University of Technology.
- Synfuels Engineering, 1982. Updated Scott-Ortch Cottonwood Wash Mine Feasibility Study. Rifle, Colorado.
- Underground Mining Methods Handbook. 1982. Ed. W. Hustrulid. SME New York.
- U.S. Bureau of Mines, 1987. Bureau of Mines Cost Estimating Systems Handbook. Information Circular 9142/9143.
- U.S. Dept. of Interior. 1975. Concrete Manual. A Water Resources Technical Publication. 8th Edition.
- Volchenko, N. G. 1977. Influence of Charge Arrangement and Short Delay Blasting On the Crushing Indices in Compression Blasting. Soviet Mining Science v. 13 p. 488.
- Western Mine Engineering, 1988. Mining Cost Service.

APPENDIX A
Supplementary Material for the
Large-Hole Stopping Method

CONTENTS OF APPENDIX A

| | <u>Page</u> |
|---|-------------|
| LIST OF TABLES AND FIGURES..... | A-3 |
| OPERATING COSTS AND PRODUCTION RATES FOR LARGE-HOLE STOPPING EQUIPMENT..... | A-4 |
| Rock Bolter..... | A-4 |
| Mechanical Miner..... | A-4 |
| Fan Drilling Jumbo..... | A-5 |
| Continuous Loader and Feeder Breaker..... | A-5 |
| ITH Drill..... | A-6 |
| Conveyors..... | A-6 |
| BLASTING LAYOUTS AND ESTIMATED COSTS FOR LARGE-HOLE STOPPING..... | A-9 |
| Blasting Cost for the Trough..... | A-9 |
| Production Blasting..... | A-9 |
| Slot Blasting..... | A-10 |
| PREPRODUCTION COST ESTIMATES FOR LARGE-HOLE STOPPING..... | A-14 |
| Raises..... | A-14 |
| Shafts..... | A-14 |
| Transportation Drifts Developed by the Contractor..... | A-15 |
| Stope and Drift Development on the Overcut..... | A-16 |
| Estimation of Preproduction Cost for Conveyor Haulage..... | A-16 |
| Transportation Drift, Trough Drift, and Crosscut Preproduction on the Undercut..... | A-17 |
| Troughs..... | A-17 |
| Ancillary Facilities..... | A-17 |
| MISCELLANEOUS OPERATING AND CAPITAL COSTS FOR LARGE-HOLE STOPPING..... | A-18 |
| Hoisting..... | A-18 |
| Ventilation..... | A-19 |
| Compressed Air..... | A-20 |
| Water Supply and Drainage..... | A-21 |
| Electrical Capital Cost..... | A-21 |
| Fuel Consumption..... | A-22 |
| Backfill Cost..... | A-22 |
| DEPRECIATION SCHEDULE FOR LARGE-HOLE STOPPING..... | A-23 |

LIST OF TABLES AND FIGURES

| <u>Table</u> | <u>Page</u> |
|--|--------------------|
| A1. Conveyor Operating Cost..... | A-7 |
| A2. Conveyor Capital Cost..... | A-8 |
| A3. Production Hoist Duty Schedule for Large-Hole Stoping..... | A-18 |
| A4. Air Requirement for Large-Hole Stoping..... | A-21 |
| A5. Electrical Power Requirement for Large-Hole Stoping..... | A-22 |
| A6. Fuel Requirement for Large-Hole Stoping..... | A-23 |
| A7. Depreciation Schedule for Large-Hole Stoping..... | A-23 |
| A8. Average Annual Interest Cost for Large-Hole Stoping..... | A-24 |

| <u>Figure</u> | <u>Page</u> |
|---------------------------------------|--------------------|
| A1. Blasting Plan for the Trough..... | A-11 |
| A2. Production Blasting Plan..... | A-12 |
| A3. Plan for the Stope Slot..... | A-13 |

END

**DATE
FILMED**

6 / 16 / 92

