

FEMTOSECOND SPECTROSCOPY OF THE FIRST EVENTS OF THE PHOTOCHEMICAL CYCLE IN BACTERIORHODOPSIN

M. C. NUSS, W. ZINTH, W. KAISER

Physik-Department der Technischen Universität München, Munich, West Germany

E. KÖLLING and D. OESTERHELT

Max-Planck-Institut für Biochemie, Martinsried near Munich, West Germany

Received 21 March 1985

The first steps in the photochemistry of bacteriorhodopsin (BR) are investigated with light pulses of 160 fs duration. Four samples are studied: (i) the purple membrane, (ii) deuterated purple membrane, (iii) BR trimers and (iv) BR monomers. In all samples the first intermediate J is formed within 430 ± 50 fs. No isotope effect is observed in the formation of J upon deuteration, in contrast to previous reports with much higher excitation energies. Thus proton movement to or from the retinal Schiff's base is not relevant during the first step. Comparing the data for trimeric and monomeric BR suggests an upper limit of 50 fs for the transfer of excitation energy from the excitonically coupled trimer to a single retinal chromophore.

1. Introduction

Bacteriorhodopsin (BR) acts as a light-driven proton pump in *Halobacterium halobium*, converting light energy into an electrochemical gradient across the cell membrane [1]. This gradient is subsequently used to synthesize adenosine triphosphate (ATP) and to drive transport processes. In this way bacteriorhodopsin mediates photosynthesis in Halobacteria. Bacteriorhodopsin's primary structure is known. The polypeptide chain of 248 amino acids folds into seven α -helical segments each spanning the entire cross section of the membrane. Retinal forms a protonated Schiff's base with one lysine 216 of the polypeptide chain. In the light-adapted state, all retinal molecules have the all-trans configuration, while the dark-adapted pigment is a 50% mixture of all-trans and 13-cis, 15-cis chromophores [2].

In most halobacterial strains BR forms trimers which are arranged in a two-dimensional hexagonal lattice within the cell membrane. The patches formed can be isolated by centrifugation techniques upon lysis of the halobacterial cells and fragmentation of the cell membrane by water. The isolated patches are

called purple membranes. Within the trimers the BR molecules are excitonically coupled, as seen by the bi-lobe type of the CD spectrum. Specific treatments of purple membranes with detergents such as octylglucoside in high salt destroy the crystalline lattice but preserve an oligomeric, presumably the trimeric, state. Other detergents such as Triton X 100 monomerize BR completely [3].

After excitation of the light-adapted pigment, bacteriorhodopsin undergoes a photochemical cycle of approximately 10 ms duration. During the cycle the intermediates J, K, L, M and O are formed, which can be distinguished by their absorption bands [4,5]. The changes of the absorption properties are accompanied by proton movements (deprotonation and protonation of the Schiff's base), by configurational changes of the retinal molecule and by conformational changes of the protein [6,7]. Experimental evidence exists that isomerisation of the all-trans retinal to 13-cis retinal occurs in the first step, i.e. the formation of J [8-10]. There are also strong indications that isomerisation is essential for the formation of the first ground-state intermediates in BR [10,11].

The first events of the photochemical cycle of bac-

teriorhodopsin have been observed in a number of publications [12–17]. Unfortunately, contradictory results were found for the picosecond events of BR, e.g., a deuterium effect, reported by some authors, could not be confirmed by others [13,16,17]. Most of the earlier experiments used very high excitation energies, where more than one photon per BR molecule was absorbed during the time of the excitation pulse. Under these conditions non-physiological reaction channels may occur. Recent experiments with low excitation energies gave no indication of differences in the kinetics between deuterated and undeuterated samples on the picosecond time scale (i.e. the formation of the K state) [16].

In this Letter we report on the very first steps of the photochemical cycle of bacteriorhodopsin with a time resolution of better than 50 fs (5×10^{-14} s) and low excitation energies. Emphasis is put on the formation of the intermediate J under conditions of protonation and deuteration. Furthermore, BR in the crystalline trimeric and monomeric states are compared to analyze the energy transfer from the excitonically coupled BR trimer to a single retinal chromophore.

2. Sample preparation

Purple membranes (PM) were prepared from *Halo-bacterium halobium* according to the procedure given in ref [18] and the membranes suspended in 0.01 M potassium phosphate buffer, *pH* 7. Deuterated samples were prepared by suspending the membranes in D_2O and illuminating the suspension with light from a 900 W Xe lamp ($\lambda > 520$ nm). After 30 min the membranes were sedimented by centrifugation (30 min, 50000g). This procedure was repeated twice. The deuterated samples were kept in 0.01 M deuterated potassium phosphate buffer. The exchange of the hydrogen at the Schiff's base nitrogen by a deuterium was confirmed with resonance Raman spectroscopy.

BR trimers were prepared by stirring PM (32 μM) in 1 M NaCl containing 10 mM morpholinopropane-sulfonic acid (MOPS), *pH* 7, and 3% octyl- β -D-glucopyranoside (OG) for three days at room temperature. The sample was then diluted to 1% OG with 10 mM MOPS *pH* 7 in 1 M NaCl and concentrated in an Amicon cell to a final concentration of 480 μM (1 M NaCl, 10 mM MOPS, 1% OG) and centrifuged for 1 h

at 200000g and 10°C. BR trimers at a concentration of 320 μM (20 OD) were thus obtained.

Monomers were prepared by stirring PM (400 μM) in 10 mM N-2-hydroxyethylpiperazine-N'-ethanesulfonic acid (HEPES), *pH* 6 or *pH* 7 containing 30 mg/ml Triton X 100 and 0.01% sodium azide for two days at 34°C. After centrifugation (see above) a BR monomer solution of about 320 μM BR was obtained [3]. Samples at *pH* 6 and *pH* 7 showed identical behaviour in CD spectroscopy and in the femtosecond experiments.

The exact state of aggregation of BR in the purple membrane (PM), the BR trimers and the BR monomers in suspension or solution is not precisely known. Therefore characteristic features are used for definition of these states:

Purple membranes (PM) are membrane patches as isolated in the procedure described above. They show characteristic diffraction patterns in X-ray diffraction experiments

Purple membranes in D_2O (PM_{D_2O}) contain membrane patches as PM, but the hydrogen at the protonated Schiff's base is exchanged by deuterium. This is verified by resonance Raman spectroscopy.

BR trimers contain trimers or trimer aggregates of BR which cannot be pelleted under the centrifugation conditions described above. They should not show the diffraction patterns found for PM but the same excitonic coupling is found for the trimeric BR and for the purple membrane PM, as analyzed by CD measurements (bi-lobe spectra with a maximum at 545 nm and a minimum at 596 nm). Furthermore these probes show no non-linear absorption as described below in section 4.

BR monomers contain monomers or monomer aggregates of BR and are similar to BR trimers, but excitonic coupling is lacking (no bi-lobe in CD spectra, λ_{max} at 564 nm).

All samples had an optical density of about 20 at 580 nm and were placed in a cell of 300 μm thickness. Prior to each experimental scan the sample was illuminated with actinic light ($\lambda > 500$ nm) for 30 min to ensure light adaptation. Additional illumination for 5 min was given between the individual scans (duration 3 min).

3. Experimental

A schematic representation of the apparatus is shown in fig. 1. A colliding pulse mode-locked (CPM) dye laser [19] yielded pulses of 110 fs duration at $\lambda = 620$ nm at a repetition rate of approximately 100 MHz. Transient absorbance changes were studied by the excite-and-probe technique. Since the cycle time to the bacteriorhodospin photocycle is about 10 ms, the repetition rate of the CPM laser had to be reduced to pulses with a Pockels cell (triggered with a repeat intermediate states of the photocycle. This was accomplished (i) by selecting pulse trains of 5 individual pulses with a Pockels cell (triggered with a repetition rate of 100 kHz, corresponding to one pulse train per 10 μ s), (ii) by using a rotating cuvette (25 Hz) with a distance of 50 mm between the sample and the center of rotation, and (iii) by focusing pump and probe beams to a spot <20 μ m diameter in the sample. This guaranteed that each pulse train illumi-

nated a new portion of the sample (angular velocity: 75 μ m/10 μ s) and that, after one revolution of the rotating cuvette (40 ms), all intermediate photoproducts had been reconverted to the starting species, i.e. the light-adapted BR.

The pulse trains from the Pockels cell were split by a beam splitter into a strong exciting and a much weaker probe beam. The interrogating probe pulse was delayed by a delay line which consisted of a corner cube reflector mounted on a translator, driven by a stepping motor (resolution of the stepping motor is 6.7 fs). The probe beam passed a half-wave plate polarizing the probe beam perpendicularly to the exciting beam. Both beams were recombined at a polarizing beam splitter and were focused non-collinearly onto the rotating sample cuvette. The absorbance changes induced by the exciting pulse were then monitored by the probe beam. The transmission change was directly measured with a silicon detector and a phase-sensitive amplifier locked to the frequency of a light chopper (1 kHz) placed in the exciting beam. Stray light from the exciting beam was strongly reduced by a second polarizer in front of the detector cell (fig. 1).

The induced absorbance changes as a function of the delay time t_D between exciting and probing pulses were averaged over several scans. The overall time resolution was deduced from the measurement of the cross correlation trace between exciting and probing pulses. These data were obtained by replacing the sample by a thin (0.1 mm) non-linear crystal. The pulse duration was found to be increased from 110 to 160 fs by the dispersion in the Pockels cell. Time zero was determined by the peak of the cross-correlation trace.

A constant background had to be subtracted from the measured absorbance change. This background resulted from the fact that not single pulses but pulse trains containing 5 pulses were used. Each pulse promotes a very small fraction of the BR molecules into the K intermediate causing a constant background when the next pulse of the same train arrives.

The intensity of the exciting pulses at the sample was kept very low. Within one pulse train only, less than 0.2% of the BR molecules absorbed a photon and entered the photochemical cycle. The maximal absorbance changes were only $\Delta A = 10^{-4}$ in all samples.

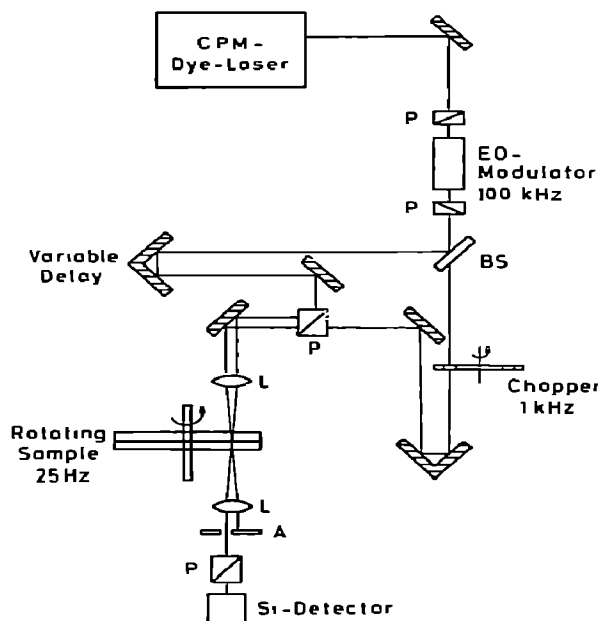

Fig. 1. Schematic representation of the apparatus for femto-second pulse spectroscopy. Pulse trains containing 5 pulses each were selected by an electro-optical (EO) modulator at a rate of 100 kHz. The sample rotated in a cuvette at 25 Hz. The exciting and probing pulse trains were selected and projected onto the sample with polarizers P, beam splitters BS and lenses L. The exciting beam was stopped at the aperture A.

4. Results

The experiments were carried out with pulses of $\lambda = 620$ nm. At this wavelength bacteriorhodopsin as well as the first photoproducts J and K absorb [16]. As a consequence a complex time dependence of the absorbance change is expected. Indeed we find four different phenomena occurring within the first five ps (5×10^{-12} s). Fig. 2a shows the data from purple membranes suspended in H_2O : (i) A strong peak of induced absorption occurs at time zero with a width of 100 fs corresponding to the coherence time of the

light pulses. (ii) Subsequently, rapid bleaching (i.e. reduced absorption) is observed. (iii) At times $t_D > 0.3$ ps the absorption increases with a time constant of 430 ± 50 fs (iv) A slow (≈ 5 ps) and small relative absorbance decrease leads to an absorbance level which remains constant for at least 30 ps (not shown in the figure).

Fig. 2b shows — on the same time scale — the time-dependent absorbance changes of purple membranes suspended in D_2O , where the Schiff's base at the retinal-lysine linkage has been deuterated. No differences of time constants and amplitudes can be seen with respect to the undeuterated sample.

In addition to BR in the purple membrane state, we investigated solubilized BR in the trimeric and monomeric state (see definition in section 2) BR

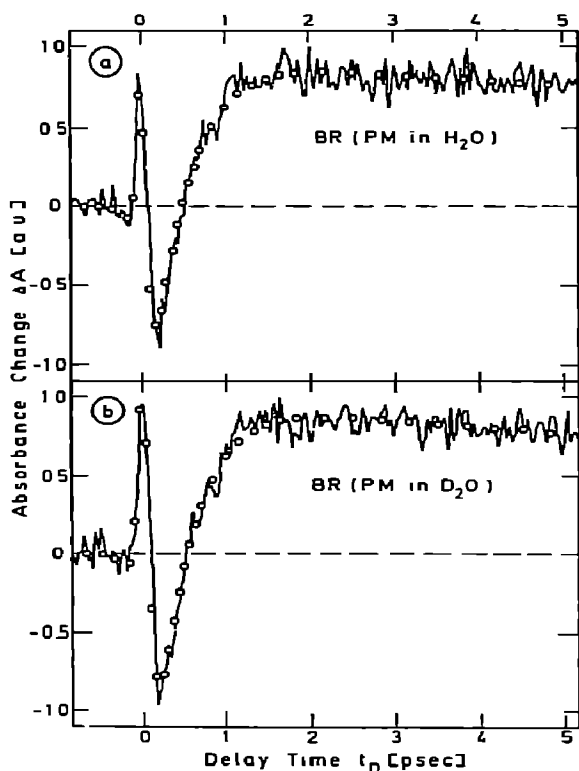

Fig. 2. Transient absorbance changes of bacteriorhodopsin in purple membranes suspended in (a) H_2O and (b) D_2O . Exciting and probing pulses of 160 fs duration and at $\lambda = 620$ nm were used. Open circles indicate least-squares fits of a rate-equation system to the data with time constants of 430 fs and 5 ps. The same time constants are obtained for the deuterated and undeuterated samples. The maximal absorbance changes correspond to $\Delta A = 10^{-4}$. The 5 ps kinetics is not seen in the monomer sample because it is covered by the 1 ps time constant.

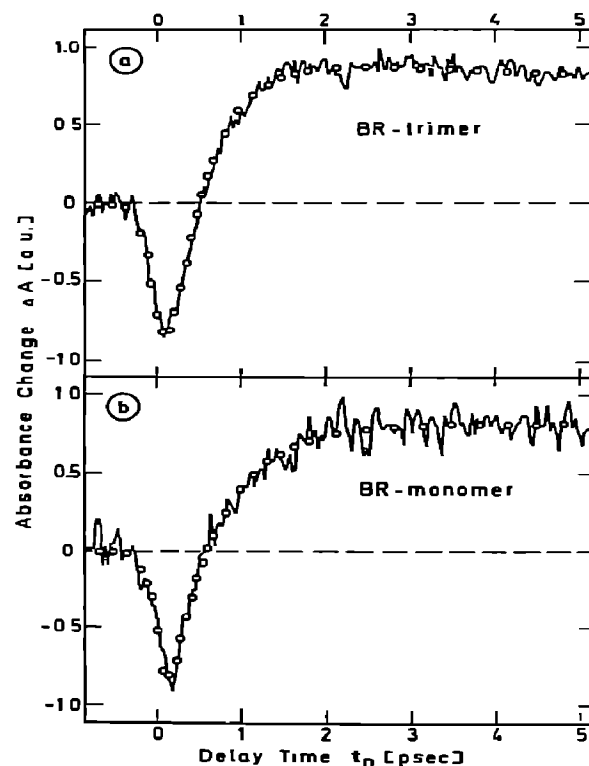

Fig. 3. Comparison of transient absorbance changes in: (a) BR trimers and (b) BR monomers. The numerical fits (open circles) yield time constants of 430 ± 50 fs, 5 ± 1 ps for the trimer and 0.4 ± 0.1 ps, 1.0 ± 0.3 ps for the monomer samples. $\Delta A_{max} = 10^{-4}$.

trimers do not form a two-dimensional hexagonal lattice but excitonically couple the three retinal chromophores. In monomeric BR this interaction between the 3 BR proteins is lost. Fig. 3 shows the absorbance kinetics of trimeric (fig. 3a) and monomeric (fig. 3b) BR. The most striking difference to the data from BR in the purple membrane state (fig. 2) is the disappearance of the peak at time zero for both trimeric and monomeric BR. At delay times $t_D > 0.3$ ps the same kinetics (time constant 430 ± 50 fs) are found for the BR trimers (see fig. 3a) as for the purple membrane (see fig. 2). In the case of the BR monomers the situation is somewhat different. two processes with time constants of 0.4 ± 0.1 ps and 1.0 ± 0.3 ps occur.

5. Discussion

The slowest kinetics we observed in all samples has a time constant of 5 ps and leads from a state of strong absorption to one of weaker absorption. Since the K state was reported to be formed within 5 ± 1 ps [16], the "final" state on our time scale is certainly the K state. The preceding absorption is attributed to the first intermediate, the J state.

The photoproduct J is formed as a result of the decay of the preceding excited singlet state S_1 of BR. This transition was not resolved in previous experiments. From a fit of picosecond experiments a time constant of 0.7 ± 0.3 ps was estimated [16]. The absorbance curves of fig. 2 show, clearly resolved, the electronically excited state S_1 , with reduced absorption compared to the BR ground state, and subsequently the reappearance of the ground-state intermediate J with a time constant of 430 ± 50 fs.

The measurements of BR in the purple membrane (fig. 2) display at time zero a strong peak of increased absorption. There at several indications that this peak is not due to a real molecular transition but is caused by a non-linear process. We recall that the cross correlation of the femtosecond pulses is measured in a non-linear crystal. Two equal pulses interact in the crystal and the generation of the second harmonic at 310 nm is observed as a function of the delay between the two pulses. It is important that second-harmonic generation is only possible in media which do not have inversion symmetry on the length scale of one

wavelength. Similarly, we observed radiation of the second harmonic at $\lambda = 310$ nm in the purple membrane state which has a hexagonal lattice structure without an inversion symmetry and a diameter of about $0.5 \mu\text{m}$. On the other hand, we could not observe second-harmonic radiation in the isolated trimers and monomers, which are much smaller. This second-harmonic generation pretends an induced absorbance in the excite-and-probe experiment of the purple membrane at time zero and is a result of the crystalline array of the chromophores in the purple membrane.

In the purple membrane the three symmetrically arranged BR molecules are excitonically coupled [20]. After light excitation the absorbed energy is first delocalized over the trimeric BR unit. This energy will be trapped subsequently by one of the three retinal chromophores in the trimer which may cause absorption changes and may delay the next steps of the photochemistry. Therefore, one has to consider an additional fast process. With the exception of the spike at time zero the femtosecond kinetics demonstrate the same properties of trimeric BR (fig. 3a) as BR in the purple membrane (fig. 2a): the same time constant of 430 ± 50 fs for the formation of the J intermediate is found. The fit of the data for monomeric BR (fig. 3b) shows two time constants of 0.4 ± 0.1 ps and 1.0 ± 0.3 ps in the formation of a state with increased absorption. We attribute the longer time constant to a considerable amount (38%) of 13-cis retinal molecules which are present even in the light-adapted specimen [21]. Thus we assign the 1 ps kinetics to the 13-cis retinal, i.e. to the BR dark cycle. Disregarding this process, we found within the experimental accuracy no retardation of J formation for the trimer samples with respect to monomers. Thus we have a strong indication that the energy trapping process from excitonically coupled trimer excited states to single retinal chromophores occurs within 50 fs.

The subpicosecond experiments presented here give new information on the molecular processes occurring in BR after optical excitation: The absence of an isotope effect in the steps $S_1 \rightarrow J$ and $J \rightarrow K$ is a strong indication that proton transfer is not the primary process of the photochemical cycle of BR[‡].

[‡] A recent paper showed an indication for a deuterium effect even in the very early steps [17]. This seems to be due to a fit to the experimental data neglecting absorbance differences between the intermediates J and K.

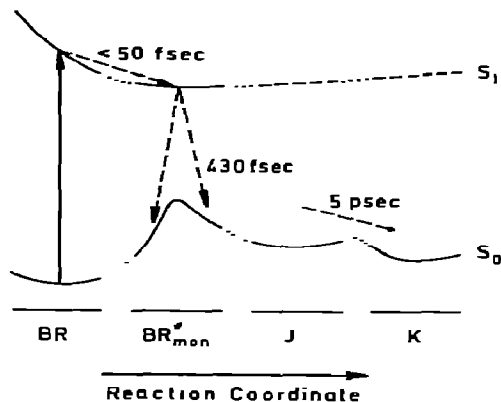

Fig. 4. Schematic model of the ground-state (S_0) and excited-state (S_1) energy surfaces of bacteriorhodopsin as a function of the reaction coordinate. Photochemistry is initiated by absorption of a photon by the BR molecule. The excitation energy is trapped in the excited state of a single BR chromophore BR_{mon}^* . Within 430 fs the molecule decays back into either the BR ground state or the intermediate J. The subsequent $J \rightarrow K$ transition is a ground-state process with a time constant of 5 ps.

On the other hand, the strong similarity of the absorption spectra of K and J and the experimental finding that K contains a 13-cis retinal [8–10,16] support the interpretation that J already contains 13-cis retinal. As a consequence, isomerisation must proceed very rapidly within 430 ± 50 fs. This short time constant is not surprising in the light of other experiments showing similar rapid isomerisation processes [22].

The molecular events are summarized in a schematic energy surface diagram (fig. 4). The absorbed photon promotes BR in an excited delocalized state BR^* of the trimer unit. The energy is subsequently trapped in the excited state of a single monomer BR_{mon}^* . From the bottom of the S_1 potential surface into the original ground state and into the isomerized 13-cis, 14-s-cis ground state (the J intermediate) takes place within 430 fs. Apparently there is no energy barrier against isomerisation in the excited state. The $J \rightarrow K$ transition is a ground-state process, where probably the rearrangement of the protein (relaxation of the oligomethylene chain of lysine 216) leads to the absorption changes with a time constant of 5 ps.

6. Conclusions

In this Letter we were able to describe the formation of the first intermediate J in the photocycle of bacteriorhodopsin under low excitation conditions and with 50 fs time resolution. The product is formed with a time constant of 430 ± 50 fs. The kinetics is *not* sensitive to deuteration of the Schiff's base. Thus proton transfer cannot be involved in this transition. Our experiments strongly support isomerisation taking place in this first step of the photochemical cycle of bacteriorhodopsin. Isomerisation starts on the excited-state energy surface of BR and is completed after 430 fs when the ground-state intermediate J is formed.

Differences in the absorbance kinetics of BR monomers and BR trimers exist (assigned to the dark cycle of BR). Energy transfer from the delocalized excited state of the trimer to a single retinal chromophore apparently takes place within less than 50 fs.

References

- [1] D. Oesterhelt and W. Stoeckenius, Proc. Natl. Acad. Sci. US 70 (1973) 2853.
- [2] G.S. Harbison, S.O. Smith, J.A. Pardo, C. Winkel, J. Lugtenburg, J. Herzfeld, R. Mathies and R.G. Griffin, Proc. Natl. Acad. Sci. US 81 (1984) 1706.
- [3] N.A. Dencher and M.P. Heyn, Meth. Enzymol. 88 (1982) 5.
- [4] R.H. Lozier, R.A. Bogomolni and W. Stoeckenius, Biophys. J. 15 (1975) 955.
- [5] M.C. Kung, D. Devault, B. Hess and D. Oesterhelt, Biophys. J. 15 (1975) 907.
- [6] M.J. Pettei, A.P. Yudd, K. Nakanishi, R. Henseman and W. Stoeckenius, Biochemistry 16 (1977) 1955.
- [7] B. Aton, A.G. Doukas, R.H. Callender, B. Becher and T.G. Ebrey, Biochemistry 16 (1977) 29.
- [8] M. Braiman and R. Mathies, Proc. Natl. Acad. Sci. US 79 (1982) 403.
- [9] C.L. Hsieh, M.A. El-Sayed, M. Nicol, M. Nagumo and J.H. Lee, Photochem. Photobiol. 38 (1983) 83.
- [10] H.-J. Polland, M.A. Franz, W. Zinth, W. Kaiser, E. Kölling and D. Oesterhelt, Biochim. Biophys. Acta 767 (1984) 635.
- [11] J.M. Fang, J.D. Carriker, V. Balogh-Nair and K. Nakanishi, J. Am. Chem. Soc. 105 (1983) 5162.
- [12] K.J. Kaufmann, P.M. Rentzepis, W. Stoeckenius and A. Lewis, Biochem. Biophys. Res. Commun. 68 (1976) 1109.
- [13] M.L. Applebury, K.S. Peters and P.M. Rentzepis, Biophys. J. 23 (1978) 375.

- [14] E.P. Ippen, C.V. Shank, A. Lewis and M.A. Marcus, *Science* 200 (1978) 1279.
- [15] Y. Shishida, S. Matuoka, Y. Hidaka and T. Yoshizawa, *Biochim. Biophys. Acta* 723 (1983) 240.
- [16] H.-J. Polland, W. Zinth and W. Kaiser, in: *Ultrafast phenomena*, Vol 4, eds D.H. Auston and K.B. Eisenthal (Springer, Berlin, 1984) p. 456; H.-J. Polland, A. Franz, W. Zinth, W. Kaiser, E. Kölling and D. Oesterhelt, *Biophys. J.*, to be published.
- [17] M.C. Downer, M. Islam, C.V. Shank, A. Harootunian and A. Lewis, in: *Ultrafast phenomena*, Vol 4, eds D.H. Auston and K.B. Eisenthal (Springer, Berlin, 1984) p. 500.
- [18] D. Oesterhelt and W. Stoeckenius, *Meth. Enzymol.* 31A (1974) 667.
- [19] R.L. Fork, B.L. Greene and C.V. Shank, *Appl. Phys. Letters* 38 (1981) 671.
- [20] B. Becher and T.G. Ebrey, *Biochem. Biophys. Res. Commun.* 69 (1976) 1.
- [21] R. Casadio, H. Gutowitz, P. Mowery, M. Taylor and W. Stoeckenius, *Biochim. Biophys. Acta* 590 (1980) 13.
- [22] B.L. Greene and R.C. Farrow, *J. Chem. Phys.* 78 (1983) 3336.