

*Vestibular System Part 2:
Psychophysics, Applied Aspects
and General Interpretations*

By

A.J. Benson · N. Bischof · W.E. Collins · A.R. Fregly · A. Graybiel
F.E. Guedry · W.H. Johnson · L.B.W. Jongkees · H.H. Kornhuber · R. Mayne
D.L. Meyer · E. Peitersen · W. Precht · K.P. Schaefer

Edited by

H.H. Kornhuber

With 198 Figure



Springer-Verlag Berlin · Heidelberg · New York 1974



W 1587

ISBN 3-540-06864-3 Springer-Verlag Berlin · Heidelberg · New York

ISBN 0-387-06864-3 Springer-Verlag New York · Heidelberg · Berlin

This work is subject to copyright. All rights are reserved, whether the whole or part of the material is concerned, specifically those of translation, reprinting, re-use of illustrations, broadcasting, reproduction by photocopying machine or similar means, and storage in data banks.

Under § 54 of the German Copyright Law where copies are made for other than private use, a fee is payable to the publisher, the amount of the fee to be determined by agreement with the publisher. © by Springer-Verlag, Berlin · Heidelberg 1974. Printed in Germany.

Library of Congress Cataloging in Publication Data. Kornhuber, Hans. Vestibular System. (Handbook of Sensory Physiology, v. 6/1-2). Contents: pt. 1. Basic Mechanisms — pt. 2. Psychophysics, Applied Aspects and General Interpretations. I. Vestibular Apparatus. I. Bagger-Sjöbäck. II. Title. III. Series. [DNLM: 1. Vestibular Apparatus. 2. Vestibular Nuclei. WL700 H236 v. 6] QP351.H34 vol. 6/1-2 [QP471] 591.1'82'08s [591.1'82]. 74-14870.

The use of registered names, trademarks, etc. in this publication does not imply, even in the absence of a specific statement, that such names are exempt from the relevant protective laws and regulations and therefore free for general use.

Typesetting and printing: Roth sel. Ww., München; Binding: Brühlsche Universitätsdruckerei, Gießen

Preface

The function of the vestibular system is not as obvious as those of vision, hearing, touch or smell. Vestibular dysfunction, however, is clearly apparent where lesions are present. It is probably for this reason that the vestibular sense was not discovered until the nineteenth century and that clinicians have continued to play a major role in basic vestibular research right up to the present. The relationship between basic and clinical research is certainly stronger in the vestibular field than in that of tactile sensation, for instance, as testified by the work of clinicians as MÈNIÈRE, BREUER, BÁRÁNY, DEKLEIJN and FRENZEL. In this respect the situation is similar in vestibular physiology and in endocrinology, and for the same reason.

This second part of the vestibular volume of the Handbook of Sensory Physiology will be of interest to neurologists, otologists, neurosurgeons, ophthalmologists and physiotherapists on the one hand, and psychologists, physiologists, engineers and aviation specialists on the other. For a full understanding of Part 2, it is necessary to have assimilated the basic anatomy, physiology, and biochemistry of Part 1.

Each sensory system has some motor aspects. Nociceptors, for instance, have a special relation to the spinal flexion reflex and to flexion spasticity after spinal cord lesions. Tactile afferents are strongly engaged in the regulation of voluntary finger, hand, lip, and tongue movements. However, there is no other sensory system where the motor aspects are as important as in the vestibular. The cerebellum has evolved out of the vestibular system; the cerebellar nuclei are analogous (in function and in their connections to the cerebellar cortex) to the vestibular nuclei. The study of the role of vestibular mechanisms in body posture and eye movements has made a substantial contribution to the theory of the motor system. The simpler organization of active eye movements as compared to limb movements has facilitated understanding. This book takes these facts into account.

It is hoped that this volume may represent a small step toward an understanding of this part of Nature's secrets and at the same time facilitate clinical knowledge about the vestibular system.

Ulm, June 1974

HANS HELMUT KORNHUBER

List of Contributors

- BENSON, A.J., Neurobiology Section, R.A.F. Institute of Aviation Medicine, Farnborough, Hampshire, England
- BISCHOF, N., California Institute of Technology, Division of Biology, Pasadena, Calif. 91109, USA
- COLLINS, W.E., Psychology Laboratory, Civil Aeromedical Institute, P.O. Box 25082, Oklahoma City, Oklahoma 73125, USA
- FREGLY, A.R., Naval Education and Training Support, Code N 213, Building 45, Naval Air Station, Pensacola, Florida 32508, USA
- GRAYBIEL, A., Naval Aerospace Medical Center, Pensacola, Florida 32512, USA
- GUEDRY, F.E., Naval Aerospace Medical Center, Pensacola, Florida 32512, USA
- JOHNSON, W.H., Dept. of Otolaryngology and Physiology, University of Toronto, Toronto, Canada
- JONGKEES, L.B.W., Academisch Ziekenhuis bij de Universiteit van Amsterdam, Keel-, neus- en oorheelkundige kliniek, Amsterdam-Oud west, Eerste Helmerstraat 104, Holland
- KORNHUBER, H.H., Abt. f. Neurologie der Universität, D-7900 Ulm, Steinhövelstraße 9, Germany
- MAYNE, R., Arizona State University, Faculty of Electrical Engineering, Tempe, Arizona 85281, USA
- MEYER, D.L., Universitäts-Nervenlinik D-3400 Göttingen, v. Siebold-Str. 5, Germany
- PEITERTSEN, E., University E.N.T. Clinic, Rigshospitalet, Blegdamsvej, DK-2100 Copenhagen Ø, Denmark
- PRECHT, W., Max-Planck-Institut für Hirnforschung, Neurobiologische Abt. D-6000 Frankfurt-Niederrad, Deutschordenstraße 40, Germany
- SCHAEFER, K.P., Universitäts-Nervenlinik, D-3400 Göttingen, v. Siebold-Str. 5, Germany

Vestibular System

Part 2: Psychophysics, Applied Aspects and General Interpretations

Contents

E. Psychophysics

Chapter I	Psychophysics of Vestibular Sensation. By F. E. GUEDRY. With 39 Figures	3
Chapter II	Optic-Vestibular Orientation to the Vertical. By N. BISCHOF. With 12 Figures	155

F. Applied Aspects

Chapter I	Nystagmus and Related Phenomena in Man: An Outline of Otoneurology. By H. H. KORNHUBER. With 16 Figures	193
Chapter II	Measurement of Otolith Function in Man. By A. GRAYBIEL. With 19 Figures	233
Chapter III	Measurement of Vestibulo-Spinal Responses in Man. By E. PETERSEN. With 3 Figures	267
Chapter IV	Modification of the Response to Angular Accelerations by Linear Accelerations. By A. J. BENSON. With 14 Figures	281
Chapter V	Vestibular Ataxia and its Measurement in Man. By A. R. FRÉGLY. With 11 Figures	321
Chapter VI	Arousal and Vestibular Habituation. By W. E. COLLINS. With 2 Figures	361
Chapter VII	Habituation of Vestibular Responses with and without Visual Stimulation. By W. E. COLLINS. With 8 Figures	369
Chapter VIII	Motion Sickness. Part 1. Aetiology and Autonomic Effects. By W. H. JOHNSON. With 5 Figures Part 2. Some Sensory Aspects. By L. B. W. JONGKEES. With 4 Figures	389 405
Chapter IX	Pathology of Vestibular Sensation. By L. B. W. JONGKEES. With 16 Figures	413
Chapter X	Characteristics of Vestibular Neurons after Acute and Chronic Labyrinthine Destruction. By W. PRECHT. With 4 Figures	451
Chapter XI	Compensation of Vestibular Lesions. By K. P. SCHAEFER and D. L. MEYER. With 4 Figures	463

G. General Interpretations

Chapter I	A Systems Concept of the Vestibular Organs. By R. MAYNE. With 21 Figures	493
Chapter II	The Vestibular System and the General Motor System. By H. H. KORNHUBER. With 20 Figures	581
Author Index		621
Subject Index		645

Part 1: Basic Mechanisms

Contents

A. Introduction

By H. H. KORNHUBER. With 5 Figures

B. Comparative Morphology and Physiology

- Chapter I The Perception of Gravity and of Angular Acceleration in Invertebrates. By H. MARKL. With 27 Figures
- Chapter II Comparative Morphology and Physiology. By O.E. LOWENSTEIN. With 20 Figures

C. Peripheral Mechanisms

- Chapter I Morphology of the Vestibular Sense Organs. By J. WERSSÄLL and D. BAGGER-SJÖBÄCK. With 60 Figures
- Chapter II The Functional Significance of Semicircular Canal Size. By G. MELVILL JONES. With 4 Figures
- Chapter III Histochemistry and Metabolism of the Inner Ear. By G.F. DOHLMAN
- Chapter IV Morphological Aspects of the Efferent Vestibular System. By R.R. GACEK. With 5 Figures
- Chapter V Physiological Aspects of the Efferent Vestibular System. By W. PRECHT. With 5 Figures

D. Central Mechanisms

- Chapter I Anatomy of the Vestibular Nuclei and their Connections. By A. BRODAL. With 45 Figures
- Chapter II The Physiology of the Vestibular Nuclei. By W. PRECHT. With 15 Figures
- Chapter III Cerebello-Vestibular Interrelations. By O. POMPEIANO. With 15 Figures
- Chapter IV The Vestibulo-Ocular Reflex Arc. By B. COHEN. With 20 Figures
- Chapter V Vestibulo-Spinal Mechanisms. By B.E. GERNANDT. With 10 Figures
- Chapter VI Cortical Projections of the Vestibular Nerve. By J.M. FREDRICKSON, H.H. KORNHUBER and D.W.F. SCHWARZ. With 10 Figures
- Chapter VII Vestibular Influences during Sleep. By O. POMPEIANO. With 10 Figures

Author Index
Subject Index

E. Psychophysics

Chapter II.
Optic-Vestibular Orientation to the Vertical

By
N. BISCHOF, Pasadena, Calif. (USA)

With 12 Figures

Contents

I. Introduction: On Orientation	155
II. Directional Constancy and the Compensation Principle	157
A. On Vertical Constancy	157
B. The Compensation Principle	157
C. External and Internal Compensation	159
D. Allowance for Compensatory Errors	160
E. Postural Direction Cues	163
F. The Significance of Vestibular Direction Cues	164
III. Visual Direction Cues and the Reconstruction Principle	166
A. The Concept of Perceptual Reconstruction	166
B. Visual Direction Cues	166
C. Visual Auto-Compensation	169
D. Feed-Forward and Feed-Back Compensation	173
IV. Optic-Vestibular Interaction and the Correction Principle	177
A. The Utilization of "Convergent Detection"	177
B. Optic-Vestibular Equivalence	177
C. Incongruity of Equivalent Signals	178
1. "Compromise" Solution	178
2. "Alternative" Solution	178
3. "Simultaneity" Solution	179
D. Error Detection and Error Correction	179
1. Error Detection	179
2. Error Correction	180
E. Determinants of the Optic-Vestibular Weight Ratio	180
References	185

I. Introduction: On Orientation

By "orientation" we mean the proper arrangement of an object within a frame of reference.

Using the term "proper" takes account of a connotation of value attached to the concept of orientation in common language. It may be understood either in a merely *formal* sense, referring to aspects of symmetry, equilibrium, and the like, or *functionally*: we may call an animal "well" or "poorly" oriented if it is able or unable to find its way home after having been displaced; or, generally speaking, if its "arrangement within a frame of reference" is such as to optimize the animal's (or its species') chances of survival.

In humans, the "arrangement" may be understood to occur in the realm either of body activity or of perceptual organization, the "object" and the "frame of reference" being defined physically in the former case, and psychophysically in the latter. We therefore distinguish between *body orientation* and *perceptual orientation*.

We speak of *spatial orientation* if the frame of reference is a spatial one. Within spatial orientation two general groups can be distinguished, with the frame of reference being the essentially horizontal *map of life space*, on one hand, and the vertical *pull of gravity*, on the other. The former group, including, for instance, the problem of homing and route perception, will not be discussed here, although both the eye (as in sun-orientation, cf. BRAEMER, 1960) and the vestibular organ (BERTOFF, 1962, 1963) seem to play an important part in these performances, too. Instead, we shall restrict discussion to orientation to the vertical where, as we shall see, optic and vestibular sense are substantially involved.

Applying the dichotomy of "body" and "perceptual" orientation to this case, we may distinguish between

(1) *postural equilibrium responses*, i.e., motor activity serving to stabilize the intended posture of the body in the field of gravity (e.g., vestibular righting responses), and

(2) *perceptual space transformations*, i.e., physiological processes monitoring the constancy of space perception in the presence of factors changing the position of sense organs.

Perceptual space transformations will be called "*external*" if non-nervous processes like muscular mechanics are involved (as in the case of eye-movements), and "*internal*" if they are confined to pure nervous system activity (for further detail, see below, pp. 159 f.).

Postural equilibrium responses and perceptual space transformations are by no means independent of each other; instead, it is commonly felt that there is one and the same system producing both. In man, to be sure, much more sophistication has been invested in the study of the latter, at least in healthy subjects. The following chapter will therefore deal mostly with problems of perceptual orientation.

This report shall be organized with a *functional* viewpoint. In a field of research where the data available are clustered on two widely different levels of complexity — reports of perceptual phenomena on one hand, and records of neuronal discharges on the other — a functional approach seems to be most promising to bridge the gap. It might, moreover, provide us with heuristic strategies for further research both in neurophysiology and in psychophysics.

Three functional principles, i.e. three major types of information processing involved in orientational achievements, shall be distinguished below under the names of "compensation", "reconstruction", and "correction". Each of these principles has been introduced and discussed by a different group of authors: Compensation processes were first postulated by K. BÜHLER (1922) and form the core of the famous, though originally not quite consistently defined "reafference principle" of VON HOLST and MITTELSTAEDT (1950); the importance of reconstruction processes has been stressed by GIBSON (1950, 1966) and MACKAY (1966); correction processes play an outstanding role in the perceptual theory of E. BRUNS-

WIK (1934, 1956). A synopsis of these three principles has, connected with partial re-formulation, first been attempted by BISCHOF (1966 b, p. 357–399). They will serve as a frame of classification of the following report.

II. Directional Constancy and the Compensation Principle

A. On Vertical Constancy

When exposed to a laterally tiltable, fronto-parallel luminous line in a dark room, a normal subject is able to estimate the slope of the line with quite satisfactory approximation: the inclination of the perceived contour to the apparent vertical nearly corresponds to the inclination of the physical contour with respect to the field of gravity. The sensory datum referred to by the brain in this estimation apparently consists in the slant of the line's retinal image or, more precisely, in the angle between the retinal projection of the line and a given reference axis fixed to the retina. This retinal image (the so-called *proximal stimulus*) serves, as it were, as the causal bridge connecting the object of interest, namely the luminous line outside in the dark room (the *distal stimulus*), and the perceived inclination (the *phenomenon*). Moreover, unless the subject contacts the distal object via an additional sensory channel (e.g., by touching), it is the *only* causal bridge of this kind.

Considering the latter we ought to be surprised that the relation between the retinal image and the distal object is by no means unique. Any particular inclination of the proximal stimulus contour within the retinal frame of reference may occur in the presence of a given slope of the distal stimulus line, because of the interference of a further independent variable, namely, the head tilt. When, for instance, the head is laterally inclined, the picture of a vertical line will appear on a retinal meridian different from the one upon which it is projected with upright head position. If the brain, in anthropomorphic terms, were to "rely" solely upon the information conveyed to it via the optic channel, it would be entirely unable to distinguish this situation from one in which the body remained upright but the line was tilted. The fact is, however, that the central-nervous perceptive mechanism is quite capable of making this distinction. This performance is usually referred to as "vertical constancy". The analysis of vertical constancy, then, has to start from the fundamental biological problem common to all constancy performances (others being, e.g., color, brightness, size and shape constancy): How can a veridical correspondence between the perceptual phenomenon and the distal object be established despite the fact that the only causal bridge intervening between them, i.e., the proximal stimulus, is disturbed unpredictably by the interference of a further variable?

B. The Compensation Principle

The solution of this general constancy problem was found, after preparatory work by HELMHOLTZ, HERING, MACH, and others, by K. BÜHLER and L. KARDOS (BÜHLER, 1922; KARDOS, 1928, 1929; BRUNSWIK and KARDOS, 1929) and later

restated by VON HOLST and MITTELSTAEDT (1950). The basic idea is this: the organism neutralizes the interference *by repeating it with reversed sign*. Since a process of this kind may aptly be called "compensatory", BISCHOF (1966 b) has proposed the term *compensation principle* to characterize this form of biological information processing.

The compensation principle is illustrated by the flow diagram Fig. 1a. The sensory channel S (generally the eye) is affected by a proximal stimulus, the latter

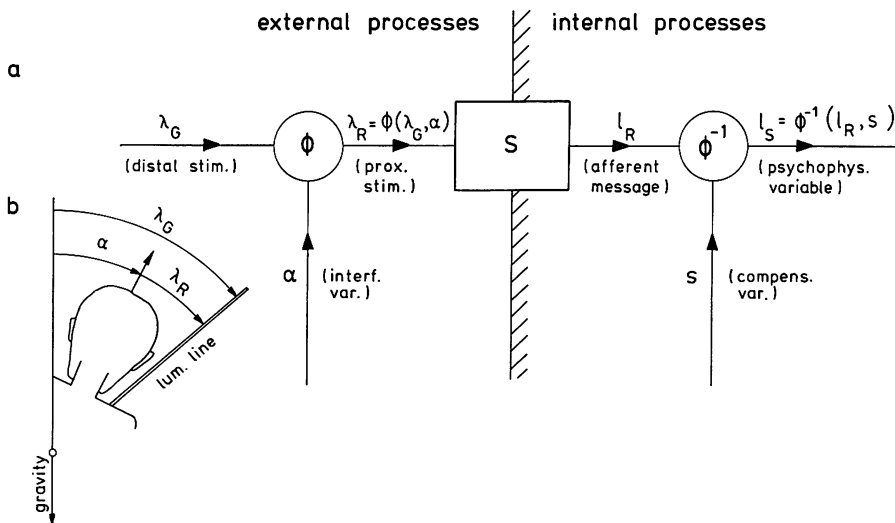

Fig. 1. a) Control diagram of the compensation principle. Here and in all subsequent block diagrams arrows represent variables, and boxes represent operators. Orientation of arrows denotes direction of causal influence. Φ = interference function, Φ^{-1} = compensatory function, S = mapping function of sensory channel. b) Interference function in the perception of verticality. Distal stimulus (λ_G) equals the *sum* of interfering variable (α) and proximal stimulus (λ_R), if orientation of angles is uniformly defined (here: clockwise inclinations positive, when viewed from Subject)

depending upon a distal stimulus and an "interfering variable", according to an "interference function" Φ . In our case, the interfering variable is the angle of head tilt (α), while the inclination λ of the luminous line relative to *gravity* (subscript G) is the distal stimulus. The slant of the line measured within the *retinal* coordinate system (subscript R) can serve as a representative of the proximal stimulus. The interference function has the form of a simple subtraction, as shown in Fig. 1b:

$$\lambda_R = \lambda_G - \alpha.$$

The proximal stimulus is reported to higher central-nervous centers by means of afferent messages (l_R). Making use of this information, now, the organism has to arrive at a psychophysical variable¹ (l_S) representing veridically the distal

1 By the expression "a psychophysical variable" we denote a hypothetical central-nervous process thought directly to underly a consciously experienced phenomenon (cf. also BISCHOF, 1966a).

stimulus. This is done by means of a compensatory process consisting of the following two operations:

(1) The organism ascertains in a suitable way a representation of the interfering variable, the "compensatory variable" (s).

(2) This compensatory variable is fed into the afferent information flow in such a way as to compensate for the influence of the interfering variable ("compensatory function").

In Fig. 1a the compensatory function is denoted by Φ^{-1} , since it can easily be seen that *in the ideal case* it would have to be exactly the inverse of the interference function. In our case, consequently, the ideal compensatory function would be an addition:

$$l_s = l_R + s.$$

In connection with the compensation principle three main questions arise: (1) Where is the compensatory process performed? (2) How should the flow diagram be modified to take account of the compensatory errors recorded under experimental conditions and in every-day life? (3) Where does the organism obtain the information about the interfering variable needed to determine the compensatory variable? These problems will be discussed successively in the following sections, with respect to the special case of vertical constancy.

C. External and Internal Compensation

As far as localization is concerned, two possible types of compensation are conceivable: (1) "external" compensation outside the boundary of neurophysiological processes, and (2) "internal" compensation within the central nervous system. Only the second possibility is taken into account in Fig. 1. The first is more obvious and easier to analyse. It consists in the so-called *ocular countertorsion* (rolling of the eyeballs around their sagittal axes). In the ideal case the amount of countertorsion should exactly equal the degree of lateral head tilt, thus leading to complete constancy of the retinal stimulus pattern. This, however, is never attained in any vertebrate species. In man, particularly, the countertorsion response can only be called vestigial (FISCHER, 1927, 1930a; WOELLNER and GRAYBIEL, 1959; SCHÖNE, 1962; MILLER, 1962; MILLER and GRAYBIEL, 1963; COLENBRANDER, 1964; KELLOGG, 1965; BRANDT and FLUUR, 1966, 1967; UDO DE HAES, 1970; BISCHOF and SCHEERER, 1970). When plotted against head tilt, ocular countertorsion shows a sinusoidal curve with extreme values occurring at tilts of about 60°. Even at its extremes, the response seldom exceeds values of 6–8°, being, therefore, far too small to account for the compensatory achievements actually observed.

Consequently, there remains only the alternative of assuming an "internal" compensation, i.e., a central-nervous processing of the optical afference according to Fig. 1. Formally, such a process could be conceived as a rotatory transformation of a functional coordinate system, the latter being the physiological correlate of phenomenal space. The anatomical localization of these processes is still open to speculation, although recent neurophysiological findings (cf. chapter FREDRICKSON,

KORNHUBER and SCHWARZ, this volume), contradicting the earlier opinion that no vestibular afferences reach the cerebral cortex, may turn out to be a first step towards answering this obscure question.

D. Allowance for Compensatory Errors

The argumentation in favor of the compensation principle (see above pp. 158 f.) may sound somewhat artificial, as it starts from the fictitious presupposition of exact veridicality of directional perception. This presupposition is, indeed, only approximately fulfilled in every-day life, and even larger deviations occur under experimental conditions.

If the optical stimulus field is reduced to a single luminous rod in a dark room, a subject's apparent vertical (as indicated by his setting of the rod) will exhibit systematic deviations from the physical plumbline, especially if the body is in a tilted position (cf. Fig. 2). Large amounts of lateral body tilt are undercompensated (AUBERT, 1861), i.e., the apparent vertical deviates towards body axis, whereas moderate amounts of tilt are sometimes overcompensated (MÜLLER, 1916), i.e., the apparent vertical deviates in the opposite direction (A and E phenomenon, respectively: UDO DE HAES, 1970; SCHÖNE and UDO DE HAES, 1971; for a review of earlier investigations, see BISCHOF, 1966c, pp. 474f.). Errors of the same order of magnitude occur with forward-backward body tilt (BRECHER and SCHUBERT, 1934; SCHÖNE, 1962, 1964; CORREIA et al., 1965). Considerable deviations are also observed when the subject is presented with an optical stimulus pattern containing one or more distinct main axes besides the luminous rod, provided that none of the main axes coincides with the pull of gravity. This phenomenon has been called "Richtungsinduktion" (directional induction) by KLEINT (1936). It obtains with such stimulus configurations as a field of parallel stripes (HOFMANN and BIELSCHOWSKY, 1909; GIBSON and RADNER, 1937; BISCHOF and SCHEERER, 1970), a grid pattern (BORING, 1952; MANN, 1952), or a luminous frame (WITKIN and ASCH, 1948; WITKIN, 1949b; PASSEY, 1950; YOUNG, 1959; NAYLOR, 1963, 1965; BERTINI, 1964; MORANT and ARONOFF, 1966). Under such conditions the subject's apparent vertical, as shown by his settings of the luminous rod, is "attracted" to a certain degree by the axes of the stimulus pattern. Directional induction effects are strongest with stimulus patterns that are closely similar to natural environments except for their slanted bearing. Such situations are created when the subject observes a natural scene through a suitable mirror system (WERTHEIMER, 1912; GIBSON and MOWRER, 1938; ASCH and WITKIN, 1948a) or through prism spectacles (KOHLER, 1951; OHWAKI, 1961; WITKIN and ASCH, 1948b; WITKIN, 1949a), or if the natural scene is tilted as a whole, e.g., in a rotatable dummy room ("haunted swing", WOOD, 1895; KLEINT, 1936; ASCH and WITKIN, 1948b; MANN, 1952); see also HOWARD and TEMPLETON (1966).

In the flow diagram (Fig. 1), three possible sources for deviations of this kind are conceivable: (i) the afference I_R may be a distorted image of the proximal stimulus configuration λ_R . (ii) The compensatory variable s may be an inaccurate representation of the interfering variable a . (iii) The compensatory function Φ^{-1} may differ from a mathematically exact summation process.

In this connection the three variables I_R , I_S , and s merit further consideration². First, these quantities are to be regarded as "hypothetical constructs" in the sense of the terminological differentiation proposed by McCORQUODALE and MEEHL (1948); i.e., they are meant to be not directly observable, but nevertheless physically existing, links of an innerorganismic causal chain. Simultaneously, however, they are "intervening variables" in the stricter sense defined by the authors — viz., they are conceived as products of a mere mental abstraction drawn out of (unknown) physiological entities likely to be in fact much more complex. The same holds for the above-mentioned compensatory operation Φ^{-1} .

² For more detailed discussion, see BISCHOF and SCHEERER (1970).

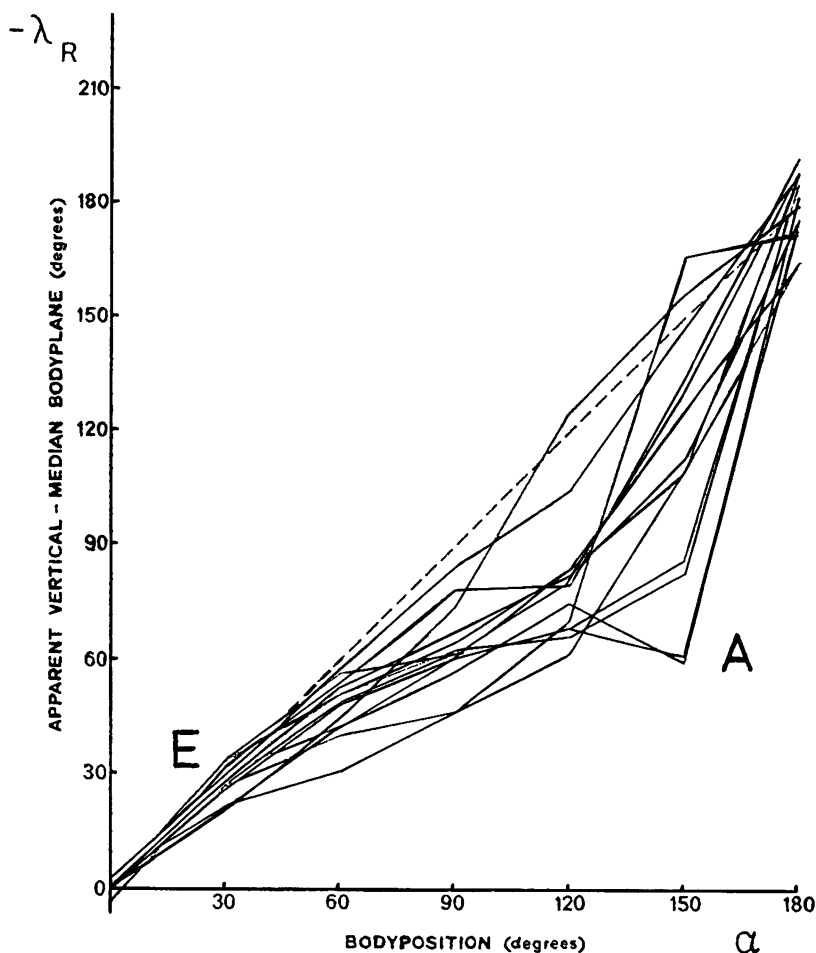

Fig. 2. Apparent vertical as a function of lateral body tilt for 13 Ss (according to UDO DE HAES 1970). Abscissa: Clockwise body tilt. Ordinate: Inclination of a luminous rod, set to Ss apparent vertical, measured in retinal coordinates with inverted sign (for explanation, see below, p. 162). Dotted line indicates ideal veridicality of directional perception. E- (MÜLLER) Phenomenon: measured value *above* dotted line (as shown in some Ss with body tilt of 30°), A- (AUBERT) phenomenon: measured value *below* dotted line (most marked in the majority of Ss under body tilt of 150°)

With regard to the three alternatives listed above, BISCHOF and SCHEERER (1970) arrive at the following proposition: If deviations from ideal veridicality in directional perception consist merely in rigid orthogonal rotations of phenomenal space without angular distortions occurring, they can be due solely to inaccuracy of the compensatory variable (alternative ii accepted), whereas the input-output characteristics of the optic channel and the compensatory summation process must be linear (i and iii rejected).

In this case, an indirect measure for the compensatory variable s could be derived from the setting of a luminous rod to the apparent vertical: If (i) $\lambda_R = l_R$, and (iii) $l_S = l_R + s$, and if further the apparent inclination l_S of the rod is zero (= vertical), then we should arrive at $\lambda_R = l_R = l_S - s = -s$. Thus the proximal stimulus λ_R with reversed sign, as plotted in Fig. 2, could serve as an operational measure for s .

As to the premise of this proposition, GIBSON and RADNER (1937, p. 464) state that the apparent vertical and horizontal "behave as if they were aspects of a single system for visual orientation"; the authors add, however, that both axes nevertheless "are not rigidly linked together; there is, as it were, a certain amount of 'play' or 'lost motion' between them". This angular distortion phenomenon was observed as an after-effect of prolonged exposure of an optical stimulus pattern containing (or consisting of) one predominating axis. Under these conditions, two factors seem to be involved in direction perception. They generate, respectively, (a) a so-called "normalization effect", which amounts to a rigid transformation of the phenomenal frame of reference as a whole (GIBSON, 1937a, b; GIBSON and RADNER, 1937), and (b) a "satiation effect", which only occurs in the vicinity of the stimulus axis, thus indeed impairing the orthogonality of space perception (KÖHLER and WALLACH, 1944). The latter phenomenon can probably be accounted for in terms of adaptation or inhibition of orientation detectors in the visual channel S of Fig. 1 (SUTHERLAND, 1961; COLTHEART, 1971; cf. also CARPENTER and BLAKEMORE, 1974). Thus, possibility (i), as listed above, cannot be ruled out entirely. However, satiation seems to be a second order effect. By factoring out the normalization effect by means of a "split-field technique", a magnitude of maximally 1.5° has been found for the satiation phenomenon (MORANT and MISTOVICH, 1960; MORANT and HARRIS, 1965).

These studies, to be sure, have only been performed with upright body posture. In a survey of the literature, unfortunately, no investigation dealing with the influence of body *tilt* on the orthogonality of space perception could be found. This leaves alternative (iii) undecided. Actually, some authors did record the apparent vertical and horizontal alternately in the same subjects as a function of head tilt, body tilt, or centrifuging, both with and without optical direction cues presented (GIBSON and MOWRER, 1938; ASCH and WITKIN, 1948a, b; WITKIN and ASCH, 1948a, b; BITTERMAN and WORCHEL, 1953, GRAYBIEL and CLARK, 1962). However, these experiments yield no answer to our problem since they are not sufficiently precise for that aim or, as in the studies of the WITKIN group, because of some peculiarities in the data analysis performed by the investigators. Nevertheless, the authors do not seem to have encountered a conspicuous decay of perceptual space orthogonality. Generally, one may presume that if body tilt and the like did produce startling angular distortions, this would have attracted the attention of some of the numerous investigators of vertical constancy during the past century, especially since under *pathological* conditions (cerebral lesions) or with *inadequate stimulation* (e.g., by electric currents) considerable distortions of the space coordinates have been repeatedly observed and reported under the name of *metamorphosia* or *dysmorphosia* by GELB (1926), BENDER and JUNG (1948), HALPERN (1949), DERWORT (1953) and others.

E. Postural Direction Cues

For the time being we may therefore assume that the errors of directional perception observed under physiological conditions are due virtually alone to the compensatory quantity s not precisely coinciding with the head inclination a . Thus the third problem stated above (see p. 159), namely, where the organism obtains a representation of a , becomes crucial. Clearly, the sources of pertinent information have to be looked for in the realm of stimulus parameters that are correlated with head and/or body tilt. Such parameters are hereafter referred to as "direction cues".

The sensory systems thought to be capable of providing direction cues are usually classified into (1) *optical* and (2) *postural* groups. The postural group may be subdivided into (a) *tactile*, (b) *kinesthetic*, and (c) *vestibular* cues.

(a) The *distribution of pressure* on the body surface may well be taken into account as a direction cue, as its maximum corresponds to the physical "down" unless, to be sure, the support at the surface of contact is in a slanted position (GIBSON, 1966). The functional effectiveness of this factor at least for the "posture reflexes" has been demonstrated by MAGNUS (1924), its relevance for verticality perception follows from experiments of SCHÖNE and UDO DE HAES (1968, 1971).

(b) Coping with gravitation necessitates a continuous tonic innervation of the whole skeletal musculature, the pattern of which has to reflect in fine gradations the distribution of forces acting upon the body. Therefore the combined messages of *tension* and *position receptors* in muscles, tendons and joints (see BISCHOF, 1966c) may well be used as a source of information about the arrangement of trunk, head, and limbs with respect to gravity. The importance of these factors is underlined by the fact that asymmetric body tonus brought about, for example, by means of additional weights is accompanied by changes of the apparent vertical (KLEINT, 1937; SCHNEIDER and BARTLEY, 1962; KLIX, 1962; WERNER et al., 1951).

(c) Whereas the two aforementioned sensory systems are primarily concerned with tasks apart from the perception of body posture in the gravito-inertial field, the vestibular apparatus appears to be constructed directly to serve this purpose.

Among the vestibular cues, both *ampullar* and *macular* messages can be shown to contribute to human perception of verticality. In the maculae, *phasic* and *tonic* responses may be distinguished, according to LOWENSTEIN and ROBERTS (1950). There are few pertinent investigations deliberately involving stimulation of all vestibular portions mentioned (e.g., VON HOLST and GRIESEBACH, 1951; UDO DE HAES and SCHÖNE, 1970). In experiments with parallel swings (JONGKEES, 1952; WALSH, 1960, 1961; SCHÖNE et al., 1967) the semicircular canals remain essentially unexcited. Devices providing steady-state head tilt, as employed by most investigators, additionally rule out phasic receptor activity in the maculae. This restricts stimulation to the tonic (non-adaptive) receptor system in the otolith apparatus, which may be considered the basic issue in postural control of vertical constancy, at least as far as the *external* compensatory mechanism (eye countertorsion, see above, p. 159) is concerned (FISCHER, 1930a; MILLER, 1962; SCHÖNE, 1962; FLUUR and MELLSTRÖM, 1970a, b).

F. The Significance of Vestibular Direction Cues

The question as to whether vestibular afference has a direct access also to the *internal* mechanisms of perceptual space transformation is comparatively more intricate.

The significance and even preponderance of the vestibular apparatus in this respect has been maintained by investigators like JONGKEES (1952), but denied by some earlier authors (ALEXANDER and BARANY, 1904; BECK, 1912; STIGLER, 1912; GARTEN, 1920); partly, perhaps, since the latter expected (and failed) to encounter particular "postural sensations", reported by their subjects. These authors did not realize that a sense organ might well have the function of solely controlling perceptual *coordinate systems* rather than contributing new *qualities* to the perceptual world.

There is, of course, great difficulty in assessing the relative importance of each of the three postural systems mentioned above, since they convey information about one and the same stimulus parameter and may mutually substitute for each other. Thus, it is in no way conclusive if, in the case of deficiency of one of them, the performance in question does not substantially decrease — especially if the subjects have been allowed to adapt to the loss.

When, e.g., GARTEN (1920) and ARNDTS (1924) could demonstrate that the ability of subjects to judge the vertical position of their bodies remains unimpaired with *tactile information* being cut off by local anaesthesia, this finding nevertheless cannot disprove the possible participation of tactile direction cues in the same performance under normal conditions or after labyrinth loss.

On the other hand the same holds true for findings according to which patients with bilateral loss of *labyrinth function*, when tilted laterally, are still able to set a luminous rod in a dark surround in rather good alignment with the physical vertical, or even surpass the achievement of subjects without labyrinth malfunction (cf. FISCHER, 1930b; GIROTTI and BORDOGNA, 1963; GIROTTI, 1963; MILLER and GRAYBIEL, 1966; CLARK and GRAYBIEL, 1966a; GRAYBIEL et al., 1968). These experiments show that the activity of the vestibular apparatus may be substituted by other postural factors, if necessary. But they do not tell us anything about the error one is likely to commit if, as a first approximation, one ignores the latter when working with healthy subjects, and interprets the results obtained in the absence of optical cues as attributable mainly to the vestibular apparatus.

There seems to be only one consistent method for determining whether in the postural system vestibular cues are of prior importance in the perception of verticality: one has to play the vestibular information off against other conflicting postural direction cues. Experiments with this particular aim show that there is little extra-otolith postural influence on verticality perception with body tilt up to 90°, whereas in body positions unlikely to occur in normal life, somesthetic factors do play a role which is, however, not very marked (SCHÖNE, 1962; SCHÖNE and UDO DE HAES, 1968, 1971; CORREIA et al., 1965).

Unfortunately, it is still an open question as to how the organism gathers information about the direction of gravitational force from the excitation patterns of *utricle* and *sacculle*, separately.

Within the framework of his "bicomponent theory", MITTELSTAEDT (1964, 1966) has called attention to the fact that the formula for rotatory transformation of a Cartesian coordinate system requires information about the sine and the cosine of the angle of rotation, and that the utricle and sacculle, respectively, could well be understood to supply this information.

Actually, there is evidence that earlier views, according to which only the utricle, but not the saccule, has a static function at all (e.g., MAXWELL, 1923; VERSTEEGH, 1927; McNALLY, 1929; TAIT, 1932) are untenable at least for birds and mammals and also for some fishes (BENJAMINS and HUIZINGA, 1927; HASEGAWA, 1935; PERLMAN, 1940; ADRIAN, 1942; JONGKEES, 1950; LOWENSTEIN, 1950; SZENTÁGOTHAÏ, 1952; HUIZINGA, 1955; MEYER ZUM GOTESBERGE and PLESTER, 1965; FLUUR and MELLSTRÖM, 1970 b). Whether, however, in the perception of verticality sacculus and utricular information is computed in the elegant way proposed by the bicomponent theory, remains to be investigated. (For pertinent theoretical considerations, see SCHÖNE, 1962; CORREIA et al., 1965; YOUNG and MEIRY, 1968; SCHÖNE and UDO DE HAES, 1970). The main difficulty with a bicomponent transformation of perceptual-space coordinates is that it could in principle be independent of otolith weight. When, however, the amount of gravito-inertial force is actually changed by means of applying *centrifugal forces* (SCHÖNE, 1962, 1964; CORREIA et al., 1965; MILLER and GRAYBIEL, 1966; SCHÖNE et al., 1967; SCHÖNE and PARKER, 1967; SCHÖNE and UDO DE HAES, 1970) marked changes of the apparent vertical do occur, showing that the aforementioned independence does not exist³.

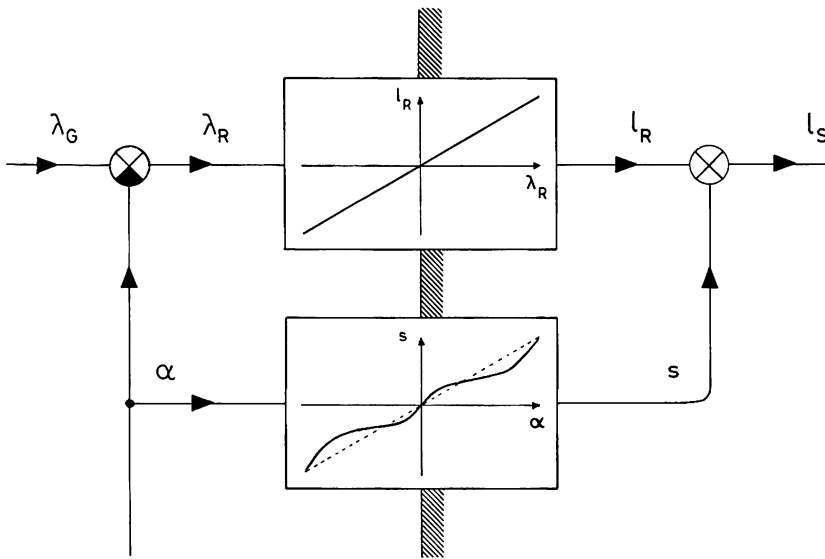

Fig. 3. Vestibular heterocompensation. Crossed circles: Operational symbols for addition. If a quadrant is black, the respective input variable is subtracted rather than added. Upper box: Visual system with linear input-output characteristics. Lower box: Otolith system with nonlinear characteristics according to Fig. 2

³ We are, of course, not referring here to changes of the apparent vertical due to changes in the *direction* (rather than the amount) of mechanical force during centrifugation. This effect is a physical triviality which never needed to be authenticated by psychophysicists, and which certainly did not deserve any pretentious labelling ("oculogravic illusion"). For a criticism of pertinent experiments designed by the GRAYBIEL and WITKIN groups, see HOWARD and TEMPLETON (1966, pp. 197 ff.) and BISCHOF (1966 c, p. 481).

While leaving this question to further analysis, we are free to characterize the function of the otolith apparatus in vertical constancy by the control diagram Fig. 3. In this diagram the A and E deviations result from the input-output characteristics of a single black-box labeled "otolith system", leaving aside intravestibular differentiations for the time being.

The particular type of network presented in Fig. 3, in which the compensatory variable is provided via a sensory channel separate from the one conveying information about the proximal stimulus, will be referred to hereafter as "hetero-compensation" (BISCHOF, 1966b). A possible alternative, called "autocompensation" of the optic message, shall be introduced in the next section.

III. Visual Direction Cues and the Reconstruction Principle

A. The Concept of Perceptual Reconstruction

The idea that the eye itself should be able to mediate perceptual information about the position of the head with respect to gravity not only seems to contradict our statements above, concerning the independence of retinal and distal coordinates (see p. 157); it also does not fit into the theoretical framework of classical sensory psychology. For the latter it was a matter of trivial self-evidence that a distal object could be immediately perceived (rather than inferred by logical reasoning) only in the presence of a proximal stimulus-pattern which to a sufficient degree "looks like" the distal object or, as GIBSON (1950) characterized this view, which can serve as a "facsimile" of the object. Since, now, neither the subject's own head nor the field of gravity is portrayed on the retina, perceptual information about these features cannot be conveyed via the optic system, according to classical understanding.

Modern perceptual psychology (cf. GIBSON, 1950, 1966; ATTNEAVE, 1954; KOHLER, 1961; METZGER, 1968) has abandoned this unreflected conception and arrived at the following principle: Although it makes sense to conceive of the perceptual phenomena as "images" of *distal* objects, it is entirely misleading to expect them to portray the *proximal* stimulus-configurations as well; a particular percept may be established on the basis of any sensory process whatsoever, provided only that the proximal stimulus concerned is at least *correlated* to the distal object. In terms of information theory, the principle maintains that the perceptual system takes advantage of the *redundancy* within its physical surroundings in a manner that could be compared to the way one reconstructs the text of an abbreviated or distorted telegram. Therefore, BISCHOF (1966b) has proposed the term "*reconstruction processes*" for this kind of stimulus elaboration.

B. Visual Direction Cues

Put in anthropomorphic terms the reconstruction principle states, in essence, that the organismic perceptual system "relies" on certain regularities "expected" in its physical surroundings (LORENZ, 1959).

Such “redundancy expectations” may be very concrete. It can be expected, for instance, that cigarette smoke rises opposite to the pull of gravity. One can show that such data, accumulated apparently in the course of individual life-experience, influence spatial perception without any noticeable intervention of higher cognitive processes (cf. KOHLER, 1951, 1953; KLOPP, 1956).

In addition to these, however, there are redundancy expectations of a far more generalized and abstract nature. For these it would be difficult to determine whether they have been acquired in an individual learning process or whether they are part of the phylogenetically preadapted organization of the perceptual system. This question, to be sure, is rather irrelevant in the present connection. With regard to vertical constancy two general redundancy expectations are of particular significance.

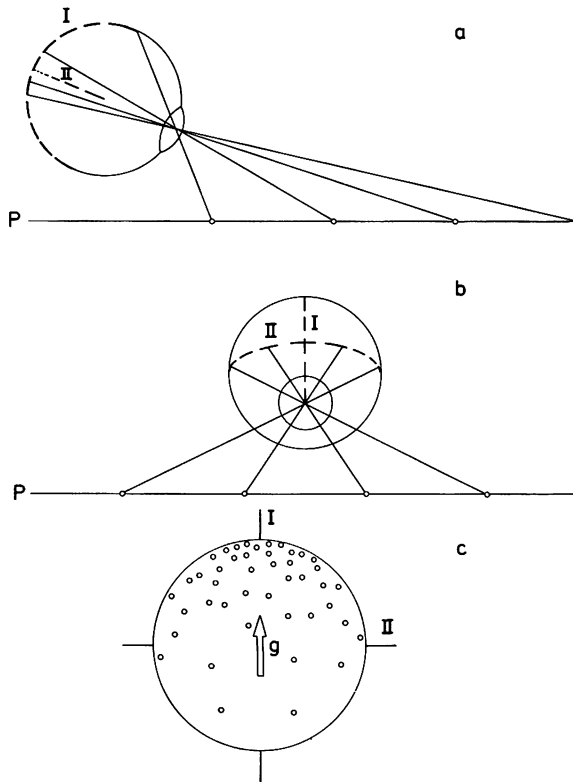

Fig. 4. Natural redundancy: Texture gradients. Equidistant marks on a plane surface (P) project on the retina in such a way that (a) the pairwise distance between proximal stimuli decreases monotonically in a retinal meridian (I) perpendicular to P, but (b) decreases symmetrically in a meridian (II) orthogonal to the former. If the marks are not equidistant but distributed in random fashion, as they are in most of the natural surface textures, the above statements would still hold true for the local average density of proximal stimulus distribution (Fig. 4c). Thus the *gradient* (g) of proximal-stimulus texture (i.e., the vector defining maximal change of stimulus density) should coincide with the physical vertical, providing that the surface regarded is horizontal

(1) The clarification of the first one has been pioneered by GIBSON (1950). It consists of two mutually independent assumptions: (a) in a natural environment the texture of large surfaces is generally homogeneous, and (b) an approximately plain surface, filling large portions of the visual field, is likely to be of horizontal extension. From these two premises the following conclusion can be drawn: the mean gradient of retinal texture density, i.e., the direction in which retinal stimulation exhibits maximal average compression of its microstructure, will usually correspond to the projection of the physical vertical upon the frontal head plane (for explanation, see Fig. 4).

(2) The second redundancy expectation, the biological utilization of which has been substantiated by many authors (like, e.g., KOFFKA, 1935), assumes that under natural conditions equilibrium-states are encountered with a probability higher than that of any other comparable states. Consequently, objects of elongated shape should be likely either to stand upright (labile equilibrium), to hang down (stable equilibrium), or to lie horizontally on the ground (indifferent equilibrium), rather than to have any other *preferential* bearing. It can be shown by means of projective

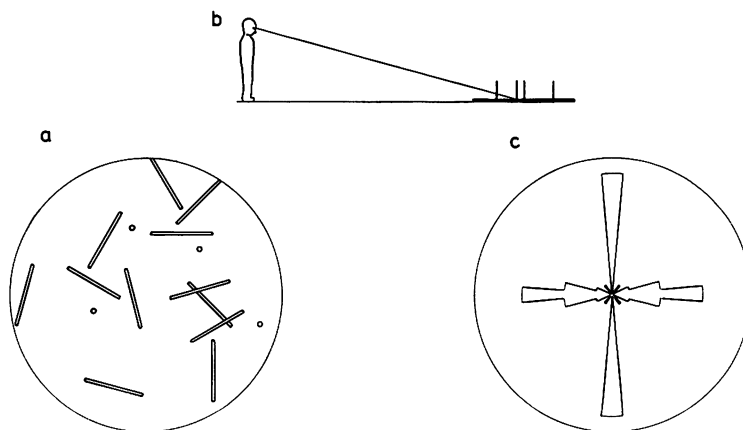

Fig. 5. Natural redundancy: Prominent figural axes. Sixteen contours of equal length, arbitrarily distributed on a horizontal surface, viewed from above (Fig. 5a). Among the contours, 4 stand upright (indicated by little circles), and the remaining 12 lie horizontally, oriented in such a way as to provide uniform angular distribution. When this arrangement is viewed from an angle of 15 degr. (Fig. 5b), the angular distribution of the retinal stimulus contours, taken in steps of 10 degr., appears as shown in Fig. 5c. Note that, although the number of horizontal contours exceed that of vertical contours by a factor of three, in the proximal stimulus distribution the peak resulting from originally vertical contours is still dominant

geometry that the outlines of such objects, when projected on the retina, form a stimulus pattern containing two prominent figural axes perpendicular to each other, and that one of these axes again corresponds to the projection of the physical vertical upon the fronto-parallel plane (see Fig. 5).

Whenever, therefore, the stimulus pattern impinging upon the retina contains a marked figural axis (particularly if the prominence of this axis is due to many

single contours being parallel to each other), this axis tends to be accepted as a cue for either verticality or horizontality. It should be noted that the directional cue thus provided may be ambiguous. At least it can easily be rendered so by proper experimental device. If exposed, for instance, to a striped field or a square frame, the optical system is left in absolute doubt as to (a) which of the two prominent axes is vertical, and (b) which end of the vertical axis is the upper.

Experiments carried out by BISCHOF and SCHEERER (1970) illustrate how the organism copes with this fourfold ambiguity. The authors investigated three (female) subjects who were tilted by means of a chair rotatable around the sagittal head axis. The subjects looked towards a stimulus pattern consisting of a circular field of twenty-five parallel stripes on a dark ground. Shining on to the surface of the striped field from a pivot at its center, was a narrow light beam, which was to be set continuously to the subject's apparent vertical. The striped field was automatically rotated with a constant angular velocity of no more than 0.5 degrees per second either clockwise or counterclockwise. In each trial, the field made one full revolution of 360 degrees (taking a time of 12 min), while body-tilt was held constant at one of seven values (0, 30, 60, 90, 120, 150, 180 degrees clockwise). The subject's settings of the luminous beam were automatically recorded on a time scale.

The responses of one of the subjects are plotted in Fig. 6; they show that the apparent vertical is indeed entrained by both the direction of the stripes (referred to as the "primary axis" by the authors) and the axis perpendicular to the stripes ("secondary axis"). Each end of both axes, alternately, behaves as the upper one. Incidentally, it can be seen that the "attractive power" of the primary axis exceeds that of the secondary axis to a noticeable degree. Applying a FOURIER-analysis to the curves shows that the primary axis is also dominant for body inclinations of $\alpha = 150$ and 180 degrees, although this is not easily recognizable in the raw material, due to noise.

These results are in substantial agreement with earlier findings of GIBSON (1937a, b) and GIBSON and RADNER (1937), who observed that in the presence of a single tilted line the apparent vertical deviates towards the line if the latter's tilt is moderate, but away from it if its inclination is nearing the horizontal (cf. also CULBERT, 1954; MORANT and BELLER, 1965).

C. Visual Auto-Compensation

When outlining in his 1966 publication what is basically the reconstruction principle, GIBSON contrasts this idea with the compensation principle in the form proposed by VON HOLST and MITTELSTAEDT (1950). According to GIBSON, the optical feed-back produced by displacement of the body is substantially different from an optical stimulation caused by changes in the distal environment. Thus the visual afference is not really "disturbed" by the body activity (a), and consequently no compensatory process is required. This consideration is felt to dispense with the concept of "a brain that copies, stores, compares, matches, and decides" (*loc. cit.*, p. 39). This remark, however, is misleading. What really turns out to be dispensable from this point of view is what we have called "hetero-compensation" (see p. 166). The need for a compensatory process as such still

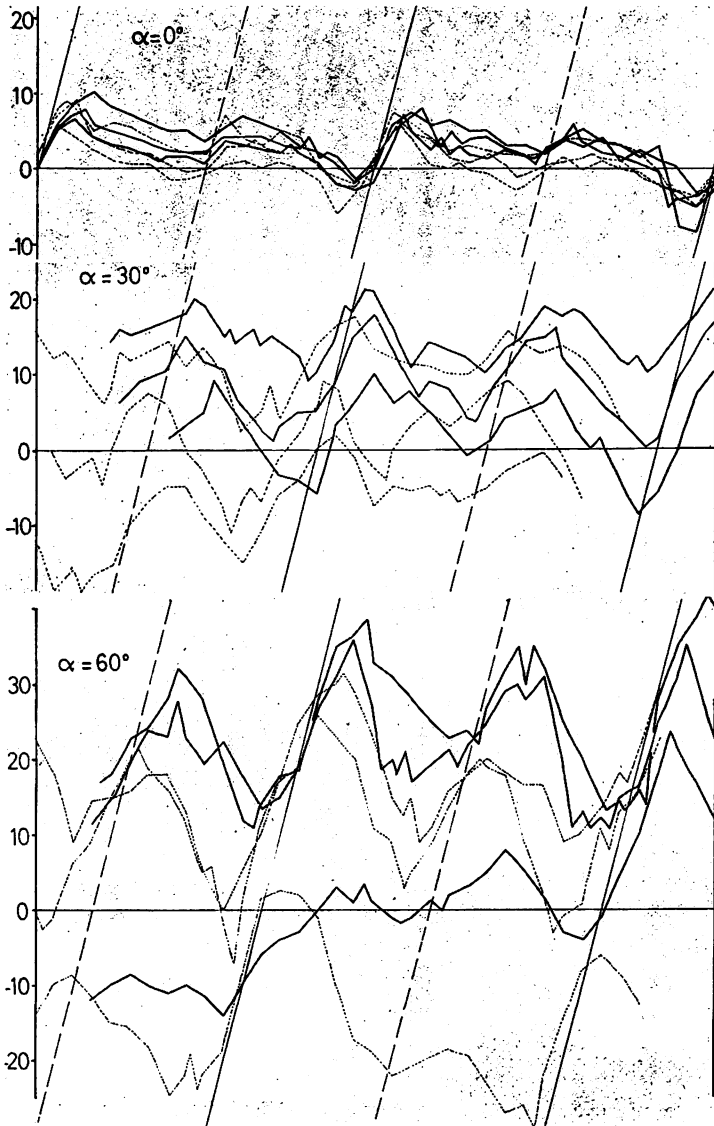
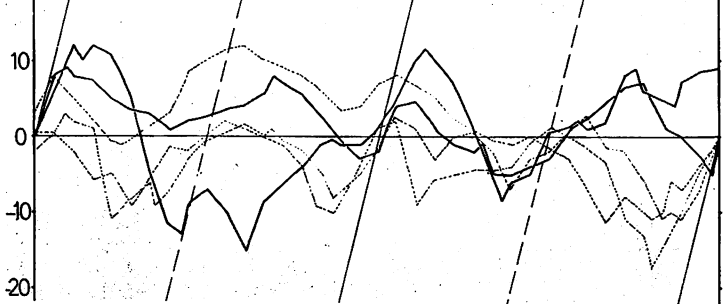
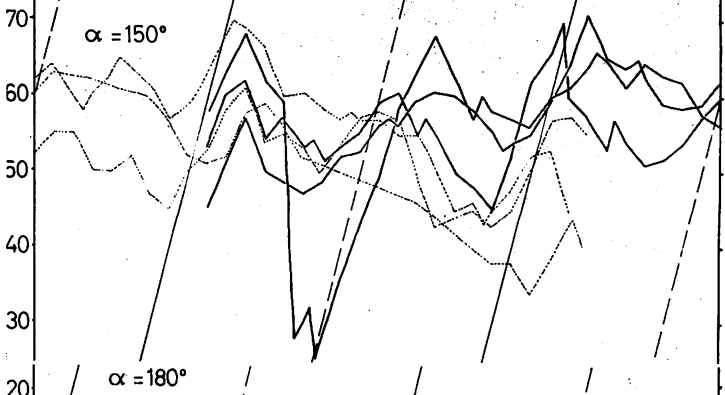
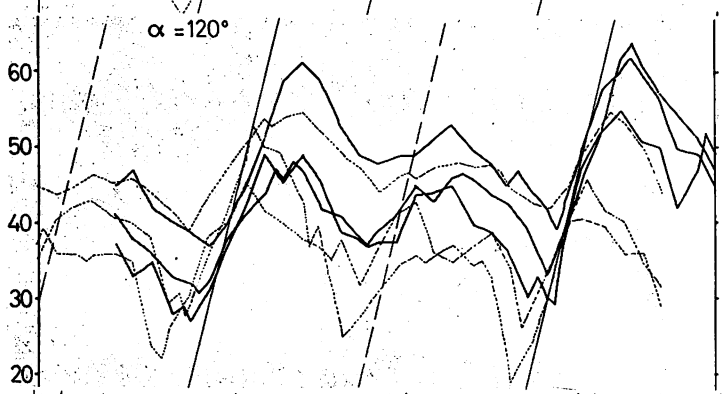
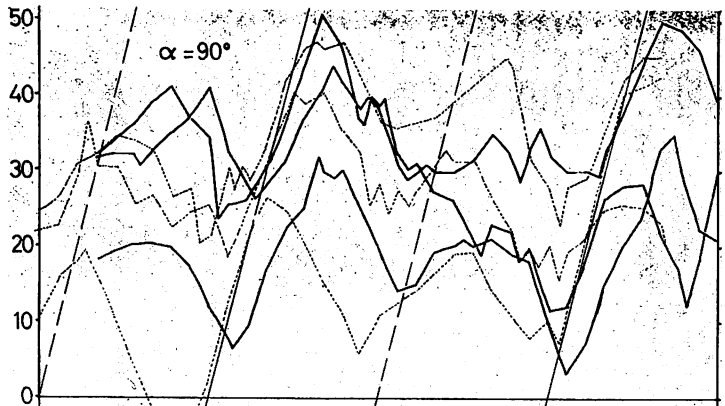

Fig. 6. Raw data of one S in the experiments of BISCHOF and SCHEERER (1970). Each single diagram (a-g) comprises about 6 measurements of the apparent vertical in one particular body position (α), the latter being specified in the upper left corners. Half of the curves are from clockwise (solid lines), half from counter-clockwise rotation of the striped field (dotted lines). *Ordinate*: Angle (λ_G) between gravity and light beam set continuously to S's apparent vertical. *Abscissa*: Angle (β_G) between gravity and primary axis of background striped field. Full length of abscissa = 360 degrees = one revolution of the striped field. Since the latter rotates with constant velocity, the abscissa may also be understood as a time scale (full length = 12 min). In this case, the abscissa reads from left to right for the solid curves, but from right to left for the dotted ones. Recordings in most cases begin about 1 min after the striped field starts to rotate, in order to eliminate onset transients. *Diagonals* indicate the position of the striped field's primary axis (solid diagonals) or secondary axis (broken diagonals). The underlying white curves are simulations computed from the model Fig. 12 (see below, p. 184)



remains. It may now be, however, of a different type, namely, what could be termed "auto-compensation".

The essentials of auto-compensation are most easily understood in the case of *motion constancy*. Looking down at an ant-heap, e.g., causes a great deal of stimulus movement on the retina. Suppose, now, that the central nervous system would simply average the messages of all the retinal motion detectors, thus computing the vector sum of the velocities of all proximal stimulus elements. Since these elementary vectors are virtually independent of each other, the outcome of the calculation would more or less equal zero. If, however, the reafferent stimulation of smooth eye movement — caused, e.g., by pursuing one particular ant — were superimposed on the retinal stimulus-processes, then the average taken would equal with considerable exactness the eye velocity (with reversed sign, to be sure) and thus be fit to function as a compensatory variable for motion constancy. This procedure evidently is followed, erroneously, in cases of so-called "induced movement" (swimming up-stream with the bridge, etc).

Speaking generally, in auto-compensation the compensatory variable is derived directly from the afferent (in our case visual) message contaminated by the interfering variable. It presupposes the existence of a *filter mechanism* that selects, utilizing redundancy-expectations, the reafferent component (a) out of the retinal message itself (cf. Fig. 7).

How the filtering process is performed in the case of vertical constancy remains unknown. Presumably contour detection as described by HUBEL and WIESEL (1959) is involved, with subsequent averaging to compute the predominant

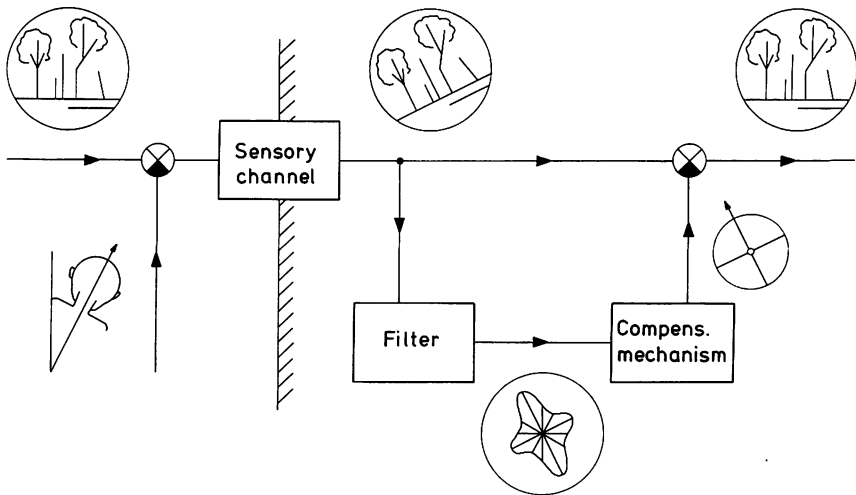

Fig. 7. Feed-forward autocompensation. A variety of distal-stimulus contours (left input variable, corresponding to λ_G in Fig. 1) when regarded with tilted head (lower left input variable, a) impinges on the retina in oblique orientation. When the resulting afferent message (l_R) is "filtered" in such a way as to compute the angular distribution of contour directions (according to Fig. 5c), the resulting main axis of retinal contour elements should, with sufficiently high probability, equal head inclination (with reversed sign). Consequently, it could be used as a compensatory variable (s , symbolized by a coordinate frame). When referred to these coordinates, the retinal afference should indeed be transformed in such a way as to render a sufficiently veridical perceptive representation (right output, l_S) of distal stimuli

proximal-stimulus axis, but for a definitive answer one must await further neurophysiological evidence. In this connection, moreover, neurophysiologists should also look for detectors sensitive to GIBSON texture-gradients (cf. p. 168).

Auto-compensation by a filter-mechanism can in some degree be compared to an *adaptive* process. The crucial difference between it and a genuine local adaptation is, however, that in the latter every site of the sensory field tends independently of the others to approach the zero-level of excitation; whereas in auto-compensation the zero-level of the entire stimulus field shifts uniquely, which has the important consequence that the differences appearing within the proximal stimulus pattern are preserved (cf. also METZGER, 1968, p. 167 ff.). In the special case of verticality perception, adaptation and auto-compensation are exemplified, respectively, by the "satiation" and "normalization" effects mentioned earlier (see p. 162).

D. Feed-Forward and Feed-Back Compensation

In all cases of auto-compensation two fundamentally different ways of feeding the compensatory variable into the optic afference are available: the compensatory variable may enter *after* the branching point to the filter (*feed-forward compensation*, Fig. 7), or *before* it (*feed-back compensation*, Fig. 8). In terms of control theory the first model has been called a "mesh", the second one a "loop" (MITTELSTAEDT, 1960).

In feed-forward compensation, provided that the filter can reconstruct the head inclination without error, the compensatory variable has to equal the filter output in order to establish ideal space constancy. In feed-back compensation, on the other hand, veridicality requires that the compensatory variable

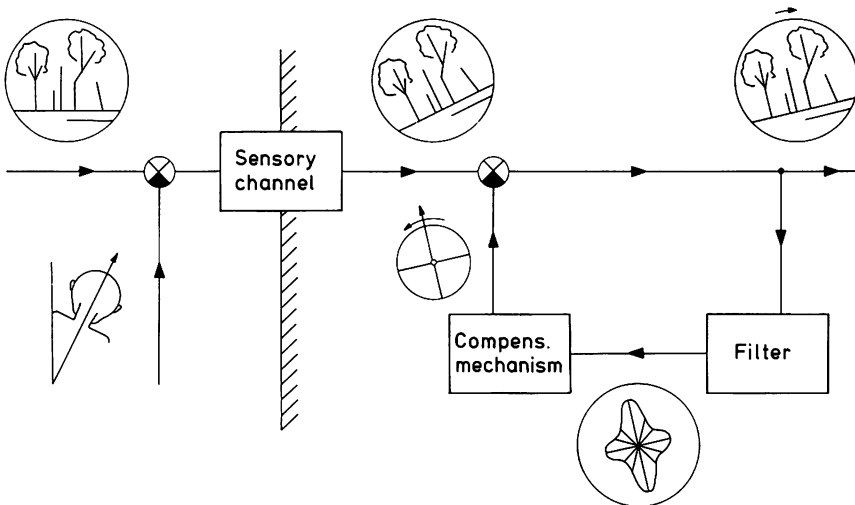

Fig. 8. Feed-back autocompensation. Differing from the system of Fig. 7 in that the perceptual output (l_s) itself undergoes the "filtering" procedure, and that the compensatory coordinate frame (s) is *rotated* as long as the inclination of the main axis of apparent contour distribution differs from zero

equal the time integral of the filter output. In the latter case, the magnitude of the compensatory variable will *change* as long as the filter output is different from zero; obviously, this process cannot come to rest with a steady value of s until the filter output has vanished, i.e., until the main axis of the perceptual field has turned *apparently* vertical. For a broader discussion see BISCHOF and SCHEERER (1970).

Which of the two possibilities is actually realized in the organism can be readily answered in the case of "external" compensation (cf. p. 159). Here, by definition, the compensation takes place outside the boundary of neurophysiological processes, whereas the compensatory variable comes from the filter that lies within this boundary. Thus, the ocular countertorsion and, incidentally, also all optokinetic reactions including nystagm, are examples for feed-back auto-compensation.

Much more difficulty arises when we try to answer the same question in the field of "internal" compensation, since here the entire network is hidden within the brain, inaccessible to direct analysis. However, BISCHOF and SCHEERER (1970) could develop a method that allowed them to solve the problem in an indirect way. We can only outline their argumentation here; for a more thorough presentation, see the publication cited.

Regarding the oscillations in Fig. 6, which are schematized in Fig. 9, it is easy to see that for each particular curve the abscissa could be partitioned into sections extending, respectively, between two successive extreme values of the oscillation of the apparent vertical. In Fig. 9a, one half of such a section is labeled as B. Each of these sections would then mark a range of stripe inclinations which have in common a particular dominance relation between the four main directions of the striped field. The abscissa of each extreme value denotes the critical inclination of the field at which one of its main directions starts or ceases to predominate over the other three in determining the apparent vertical. What, now, causes the dominance to shift from one main direction to the next? Evidently, in the course of field rotation each particular main direction is alternately perceived to be more and more, and then less and less, likely to be a valid representative of the physical vertical. This, however, presupposes a *standard* reference with which the perceptual system may decide about accepting a given optical main direction as a cue for verticality (cf. also DAY and WADE, 1969). Presumably, the additional information required for this decision is supplied by the postural senses. However, this information appears in crucially different forms in feed-forward and feed-back compensation, respectively.

(1) *In feed-forward compensation* (Fig. 7) the standard determining the dominance relations within the set of optical main directions would consist essentially⁴ of the vestibular compensatory variable (the "vestibular vertical") established according to Fig. 3. Thus, the inclination of a particular optical main direction with respect to the *vestibular vertical* decides about the acceptance of this direction as an optic cue for verticality. The vestibular vertical, however, depending as it does upon postural stimuli that are kept constant during each trial, should be expected to show limited systematic shifting at most, even when one allows for

⁴ Possible other postural cues (non-vestibular, non-optic) are being neglected here; this, however, is not relevant in the line of argument.

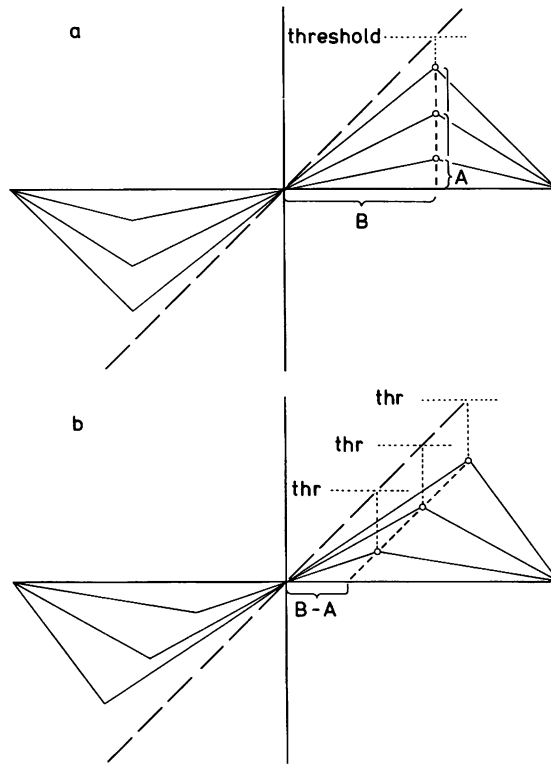

Fig. 9. Comparison of alternative compensatory mechanisms. Oscillations of an apparently vertical light beam. Ordinate: Angular inclination of light beam with respect to the DC component of oscillation (the latter representing the vestibular standard). Abscissa: Time; solid lines: settings of light beam for different body inclinations. Broken diagonals: Position of one particular main axis of the striped field. a) *Feed-forward compensation*. When the striped field axis has deviated far enough from the vestibular standard and reached a threshold (horizontal dotted line), the dominance will be taken over by the next axis. Hence the light beam would cease following the first axis and turn back to meet the next one. The curves should therefore show extreme values at this point. Since this process ought to be independent of body tilt, the maxima should all occur at the same time (B) in the cycle, irrespective of the amount (A) of oscillation. b) *Feed-back compensation*. If, however, the dominance of the striped field axis depends upon its deviation from the apparent vertical, i.e., from the respective light-beam curves, the threshold (dotted lines) will vary with the amplitude of oscillation. Thus all extreme values should now have a position such that their distance to the broken diagonal is constant. This distance ought to be the difference between the abscissa value (B) and the ordinate value (A) for every extremum

moderate changes due to system dynamics (transfer characteristics and the like) of the sensory systems concerned (cf. MÜLLER, 1916; MILLER and GRAYBIEL, 1963; GEISSLER, 1965; MCFARLAND and CLARKSON, 1966; CLARK and GRAYBIEL, 1966 b; SCHÖNE and UDO DE HAES, 1968; UDO DE HAES and SCHÖNE, 1969). Hence the ranges of influence of the four main directions in the striped field are distributed according to a standard reference direction that remains virtually fixed during

any given trial. To be sure, the reference direction will change from trial to trial, owing to there being different head inclinations, but within each of these it will remain essentially constant. This means, however, that we should find the sections of the abscissa apportioned by one and the same ratio regardless of head inclination, as indicated in Fig. 9a.

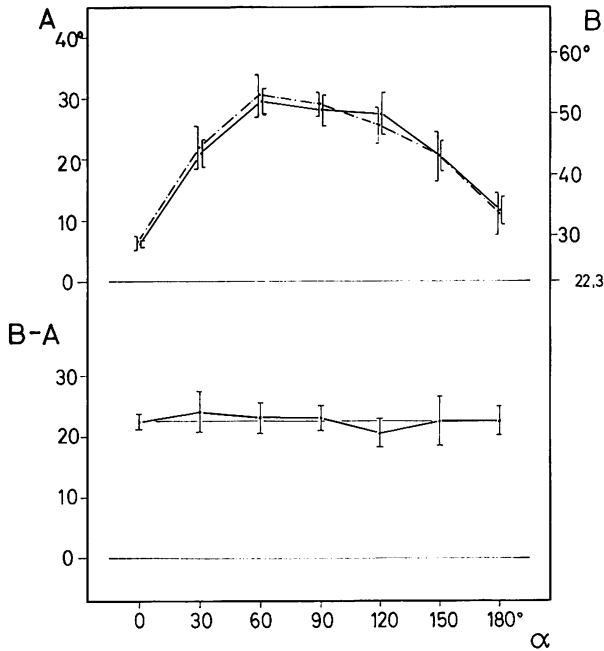

Fig. 10. Experimental support of feed-back autocompensation hypothesis in the perception of verticality (from BISCHOF and SCHEERER, 1970). Comparison of ordinate (A: solid lines) and abscissa (B: broken lines) for extreme values of apparent vertical (cf. Fig. 9). Mean values of three subjects, with average variance of means shown by bars. B scale shifted so as to accomplish maximal coincidence of curves. Evidently, B is dependent on head inclination (abscissa), whereas B-A is not

(2) Hypothesizing *feed-back compensation* (Fig. 8) yields quite different predictions. In this case the optic messages do not reach the filter mechanism before having undergone the (combined optic-vestibular) compensatory process that transforms them into the final coordinate system of apparent space. It is thus the *apparent* inclination of the four optical main directions (rather than their inclination with respect to a postural standard) that determines the partitioning of their spheres of influence. In other words, with feed-back compensation the apparent vertical, as represented by the luminous beam controlled by the subject, serves as the reference required for the validation of the optical main directions. Defined in this fashion, however, the reference is no longer invariant during a trial, and it varies, moreover, in a different way with different head inclinations. With feed-

back compensation, consequently, the abscissa sections between extreme values in Fig. 6 would not be apportioned independent of head inclination. Only if we refer the stripe inclination at every moment to the position of the apparent vertical, i.e., if we project the extreme values, as in Fig. 9b, parallel to the diagonal broken lines, rather than perpendicularly, should we obtain an invariant partitioning of the abscissa.

BISCHOF and SCHEERER (*loc. cit.*) could show, that, with this latter transformation carried out, the partitioning of ranges of influence among the four optical main directions in fact becomes invariant relative to head inclination (see Fig. 10). This indicates that the internal auto-compensatory system of visual perception of verticality is of the feed-back type.

IV. Optic-Vestibular Interaction and the Correction Principle

A. The Utilization of "Convergent Detection"

The simultaneous occurrence of both (optical) auto- and (vestibular) hetero-compensation in human vertical constancy sheds light on another peculiarity of perceptual information processing. Apparently, compensatory achievements are confined within the limits of precision of the mechanisms that provide the compensatory variable s . When, owing to possible shortcomings in information conveyance or computation, the compensatory variable does not exactly correspond to the interfering variable a , then s is unable to balance the effect of a exactly, and the interference is under- or overcompensated. The A and E phenomena described above (see Fig. 2) are examples of this.

In order to minimize such errors, the organism often seeks to provide information about an interesting distal item by using, in parallel, a plurality of sensory channels which are susceptible to different kinds of disturbing effects. Thus, the probability of error can be reduced by "convergent detection", as it were, a possibility that has been repeatedly discussed in psychological literature (cf. especially BRUNSWIK, 1934, 1940, 1956). For reasons that will be explained later (see p. 180), BISCHOF (1966 b) has proposed the term "correction principle" for this method of perceptual information processing.

B. Optic-Vestibular Equivalence

Separate sensory data which provide information about one and the same distal issue, and which are, accordingly, exchangeable with respect to their biological significance to the organism, will be referred to in the following as "*equivalent signals*". In this respect, a remarkably close relationship exists between optical and vestibular messages: for every particular output of the vestibular organs there exists an equivalent optical signal-parameter; likewise, every motor or perceptual effect known to be controlled by vestibular inputs can also be elicited by proper optical excitation.

More particularly, stimulation of the *semi-circular canals* is equivalent to visual excitation produced by uniform movement of the entire stimulus field. The perceptual results of the latter are usually referred to as "*induced movement*"

(DUNCKER, 1929; LINSCHOTEN, 1952; cf. also GIBSON, 1950, 1954); the corresponding motor reactions are known under the name of “*optokinetic responses*”. The optical counterparts of stimulation of the *otolith organs* have been discussed in an earlier section (see pp. 166 ff.); their perceptual effect, viz., their influence on the apparent vertical, has been termed “*directional induction*” by KLEINT (1936), with obvious reference to DUNCKER. In labeling the corresponding motor reactions, it might be convenient to speak of “*optostatic responses*” in analogy to “*optokinetics*”. The impairment of body balance while observing a slightly but uniformly slanted mountain meadow is an optostatic effect, as is the “*dorsal light reaction*” in fishes (VON HOLST, 1950). The occurrence of optostatic eye counter-torsion in man has been reported by GREENBERG (1960) (cf. however HOWARD and TEMPLETON, 1964 b).

Note that optic and vestibular signals are *not* equivalent with respect to information concerning straight body movements. Here only the eye is able to convey reliable information (GIBSON, 1954), and not the vestibular apparatus, contrary to repeated speculations (e.g., by MAGNUS, 1924). Whether and how messages of the latter may yet play some role in this connection, will not be discussed here (cf. BISCHOF, 1966 c, p. 483 f).

C. Incongruity of Equivalent Signals

Like reconstruction processes, the method of convergent detection is also based on the utilization of redundancy — not, to be sure, within the domain of distal objects, but rather on the level of sensory messages referring to these objects: the organism tries to keep on the safe side by seeking information from different “*warrantors*”. But what if those warrantors are at odds with each other; i.e., what if equivalent messages exhibit *incongruity*? In general there are three possible organismic reactions in such a situation; all three do also appear in the special case of optic-vestibular incongruity.

1. “Compromise” Solution

The most usual organic reaction encountered with optic-vestibular incongruity is the calculation of a weighted average of the competing messages. The weight factors involved in this type of information processing will be discussed below (see pp. 180 ff.). Evidently, the results of the experiments of BISCHOF and SCHEERER (1970), as depicted in Fig. 6, can be understood as compromise solutions of this type. VON HOLST (1950) and BRAEMER (1957) obtained comparable results with fishes.

2. “Alternative” Solution

A second possibility is that the organism takes account of only one of the competing signals while entirely blocking the others. The dominance may or may not flip-flop between the signals concerned. Here, again, weight factors are likely to play a role. Effects of this kind may be encountered if very suggestive optic direction cues, for instance a (tilted) dummy room, are viewed in upright body position. Some subjects of KLEINT (1936) reported that under these circumstances the dummy room appeared to them alternately tilted and upright.

3. "Simultaneity" Solution

Whereas the two previous solutions to the incongruity problem will always provide an unequivocal basis of orientation, there are cases in which the incompatible signals reach conscious perception simultaneously, without mutual suppression. It may be questioned, of course, whether we can speak of a "solution" here, as the resulting perceptual phenomenon is over-determined in a paradoxical way, unfit for being reacted to. If, for example, a subject remains stationary, surrounded by a dummy room that rotates slowly around a horizontal axis, he generally experiences his body at first to be somewhat tilted in the opposite direction; subsequently he feels that his body keeps rotating, yet that its position no longer changes: the experience of motion ("I am rotating with constant angular velocity") and the experience of position ("I never reach the head-down posture") break apart (KLEINT, 1937; cf. also DUNCKER, 1929; OPPENHEIMER, 1935; METZGER, 1940, 1954, p. 150). — Even in the absence of visual information, some subjects experience two possibilities of setting a luminous line to apparent verticality simultaneously under body tilt of about 150° . This would indicate a conflict within the postural cue system (FISCHER, 1930; UDO DE HAES and SCHÖNE, 1969; GRAYBIEL and CLARK, 1962; MILLER and GRAYBIEL, 1966; cf. also below, p. 182).

D. Error Detection and Error Correction

The practice of obtaining information about the same item through parallel channels is in some measure analogous to that of modern communication technique, which uses, for conveying a message over a single channel, a number of symbols that exceeds the theoretically required minimum. Both methods utilize signal redundancy, and both do so for the sake of the advantage that in case of error the receiver is supplied with at least (1) a warning that an error is present, but perhaps also (2) with cues for its correction.

1. Error Detection

The receiving system can tell from certain irregularities in the signals received — in the case in point, from the incongruity of equivalent messages — at least *that* an error has occurred, although it may have no idea at which particular place. There is indication that the sensory systems react to this kind of "alarm" by forwarding only in a restricted form (with a proviso, as it were) the message likely to be erroneous. The corresponding phenomenal quality is often referred to by the subject with terms like "uncertain", "vague", "feeble", "faint", "unconvincing", "unreal", and the like (cf. METZGER, 1954, pp. 109f.). From experiments with the "haunted swing", for example, it is known that under conditions of strong optic-vestibular ambiguity a weakening, even a loss, of phenomenal verticality may result; in the extreme case, the subject may become unable to assign the terms "up" and "down" to *any* direction of his phenomenal space (KLEINT, 1936, 1940).

A particularly vigorous reaction of the organism to error warnings due to incongruities within the optic-vestibular domain consists, according to many authors, in the phenomenon of *vertigo*. Indeed, certain distinct features of this response, like anxiety and release of primitive security reflexes (clinging), may

well be understood as emergency measures in the face of threatening decomposition of space orientation. For more details, see the chapters F.VIII; IX; G.I. in this volume.

2. Error Correction

In certain communication systems the receiver may not only be informed, by inconsistencies in the message, that an error has occurred, but also where it is probably sited and what the original text most likely was. We have reason to believe that the method of convergent ascertainment in the perceptual system also works as an error-correcting routine in this sense. That is why we have proposed the term "correction principle" here.

Above (see p. 178) we introduced the notion of "*weight factors*" that control the relative power available to equivalent sensory messages when they compete with each other in the case of incongruity (cf. KLEINT, 1936). The evidence obtained up to now allows us to conjecture that those weight factors tend to be computed according to the following rule: The less a signal is likely to convey an erroneous message (i.e., the more and the better cues speak in favor of its reliability) the higher is it weighted in competition with contradicting equivalent signals (BRUNSWIK, 1956; KLIX, 1962). Thus we may tentatively summarize the *correction principle* as follows: The organism reduces the probability of error in the perceptual processes by providing for equivalent messages through different sensory channels and then "relying" exclusively or preferably upon those whose validity is supported by the better cues.

E. Determinants of the Optic-Vestibular Weight Ratio

In his classical investigations on the equilibrium responses of fish during conflicting optic and vestibular stimulation, VON HOLST (1950) coined the term "statisch-optische Verhältniszahl" (translatable as "vestibular-optic weight ratio") to refer to a specific parameter that expresses the degree to which the vestibular righting-response prevails over a conflicting dorsal light reaction (cf. also BRAEMER, 1957). VON HOLST defined this coefficient as the cotangent of the angle between the dorso-ventral axis of the fish and the plumb line, recorded under conditions of horizontal light incidence. For the results to be interpretable the angle had to be measured when the fish was in a state of physiological equilibrium, i.e., after possible postural reflexes had ceased. Because of the latter condition VON HOLST's definition of the "vestibular-optic weight ratio" is suitable only for experimental situations in which the subject senses his body to be vertical. For perceptual experiments in which, by body fixation, every possible feed-back of the apparent vertical on body posture is blocked and in which, therefore, body inclination and apparent vertical do not necessarily correspond, a different way of defining the weight ratio is advisable. For reasons to be elucidated below (see p. 182), BISCHOF and SCHEERER (1970) suggest taking the *average range of oscillation* of the apparent vertical, under conditions of steady rotation of the optical pattern around the visual axis, as an index of the weight ratio discussed.

In distinction to VON HOLST's term, we feel it would be better to speak of an "*optic-vestibular weight ratio*" here, since the value of the coefficient — the mean amplitude of oscillation in Fig. 6 — increases monotonically with optic predominance.

The factors governing the optic-vestibular weight ratio (however defined) have not yet been thoroughly investigated, partly because for years authors have engaged in a fruitless debate as to which of the two sensory channels, the optical or the vestibular, is "prior" or "more basic" to the perception of the vertical, instead of taking for granted that *both* are important and simply asking how they interact (for a critical review of this discussion, see GIBSON, 1952).

1. As far as the *optical* determinants of the optic-vestibular weight ratio are concerned, we know this much: with labyrinthine stimulation constant, the induction of the apparent vertical by a striped field rises with the size of the latter and with the number of parallel contours within it; when patterns of higher complexity are used, the induction effect is enhanced according to the degree of their similarity to natural scenes (for references, see above, p. 160). These findings harmonize well with the correction principle, since each of the factors mentioned apparently makes it more probable — outside the laboratory situation — that the main direction of the retinal stimulus field coincides with the direction of gravity.

2. Less transparent is the biological advantage of certain *intra-organismic* factors influencing optic-vestibular competition. Between different fish species, for instance, considerable variation in the vestibular-optic weight ratio has been found by VON HOLST (1950) and BRAEMER (1957). In man, typological differences are asserted to occur: women and children give comparably more weight to visual stimuli than adult males, according to WITKIN et al. (1954). It is difficult to see what all this should have to do with the "reliability" of optical or vestibular cues. Actual needs, moods, attention and the like can also influence the perceptual response in optic-vestibular conflict situations. VON HOLST (1948) could demonstrate that the body inclination of laterally illuminated fishes is markedly enhanced when objects of high motivational valence (e.g., food) are presented. The animal, as it were, becomes "all eyes" and consequently rates the light source as a directional cue comparatively higher than he otherwise would, although the light source is not his object of attention at all and certainly has not become any more "reliable." The effect of light intensity upon the weight of optical directional cues (CURRAN and LANE, 1962) may be mentioned in this connection. Findings like these suggest that the correction principle should not be understood as a general postulate, but rather as a heuristic principle.

3. The *vestibular-somesthetic* influences upon the optic-vestibular weight ratio are, again, interpretable in "reliability" terms. According to observations of VON HOLST (1950), shaking the water in an aquarium, simulating surf, is apt to enhance considerably the optical component with some fish species. In this experiment, the laterally illuminated animals inclined their bodies more and more towards the light source, only gradually returning to the previous position after the water movement had stopped. VON HOLST also noted that an increase in hydrostatic pressure tends to augment the weight of the vestibular component. This, too, can be understood teleonomically, since water pressure normally rises with depth and is thus positively correlated with the calmness of the water layer and, consequently, with the reliability of the vestibular positional messages.

The most important problem concerning vestibular control of the optic-vestibular weight ratio is the dependence of the latter upon *body inclination*.

Information about this dependence has been provided for head tilts up to 40° by earlier authors (HOFMANN, 1910; VERNON, 1935; WITKIN and ASCH, 1948; WITKIN, 1949) and extended to 180° by BISCHOF and SCHEERER (1970) and SCHÖNE and UDO DE HAES (1971). According to the correction principle, the visual induction of the apparent vertical should be minimum in upright position, since with slight or no body tilt the precision of the statolith apparatus is maximal. This expectation was confirmed in all investigations cited. Additionally, however, one would predict a maximal visual induction effect in a body position of $150\text{--}180^\circ$, since in this range the A-deviation, the variance of the apparent vertical, the subjective uncertainty, and also the influence of various other directional cues, are all known to be maximal (cf. QUIX and EIJSVOGEL, 1929; BROWN, 1961; CORREIA and GUEDRY, 1964; SCHÖNE, 1964; GUEDRY, 1965; BENSON and BODIN, 1966; SCHÖNE and UDO DE HAES, 1968, 1971; UDO DE HAES and SCHÖNE, 1969; UDO DE HAES, 1970).

Actually, the results of SCHÖNE and UDO DE HAES (1971) seem to confirm this expectancy. They exposed to their subjects a stimulus pattern consisting of a single line and a striped field, both rigidly connected so that the stripes formed a fixed angle of either plus or minus 15 degrees with the line. The subject, that is, when adjusting the single line to his apparent vertical, had to move the striped field as well, which therefore kept appearing to him inclined by 15 degrees in clockwise, or counterclockwise direction. In both conditions, the settings for the apparent vertical differed, due to directional induction, and the angle between both settings turned out to be greatest with a body tilt of 150 degrees.

However, the authors call attention to their method being rather susceptible to the well-known effect (cf. p. 179) that the vestibular vertical can be equivocal with extreme body tilt. If, say, with $a = 150^\circ$ the vestibular vertical has two different possible positions, it is difficult to tell from the data obtained by SCHÖNE and UDO DE HAES whether the visual induction of the apparent vertical was due to a flip-flop kind of effect, or to a greater tolerance of any *one* of both possible states against continuous deflection. This distinction can easier be made using the method of BISCHOF and SCHEERER (1970). Actually, Fig. 6f (cf. p. 171) shows one case (lowest unbroken line) in which a temporary shift between two possible DC-states of the apparent-vertical might have occurred. Normally, however, there were no such shifts, and the optic-vestibular weight ratio, defined as the average range of oscillation, was most marked with body inclinations between 60 and 90 degrees (cf. Fig. 6). Surprisingly enough, the optic-vestibular weight ratio, when plotted against body tilt, rendered a curve that was highly correlated with the counter-torsion characteristic of the subject's eye (cf. Fig. 11).

Fig. 11. Mean range of oscillation of luminous beam setting (ψ = filled dots and solid lines) and ocular countertorsion (ρ = empty dots and broken lines), plotted against body tilt (a) for three Ss. Raw data and mean values (from BISCHOF and SCHEERER, 1970). Ordinate scale ratio $\psi : \rho = 1.48$ calculated such as to minimize square difference of means over all three Ss. Note that there is not only a satisfactory proportionality between ψ and ρ but that even the factor of proportionality can be taken to be the same in all three subjects: the S with the highest amount of eye countertorsion (Vp H) also shows the widest oscillations of the apparent vertical in the presence of a rotating striped field. Considering the small number of Ss, the latter effect, of course, should not be generalized at the moment

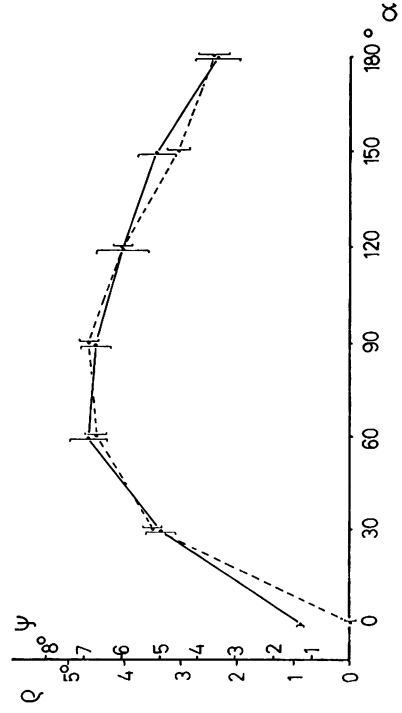
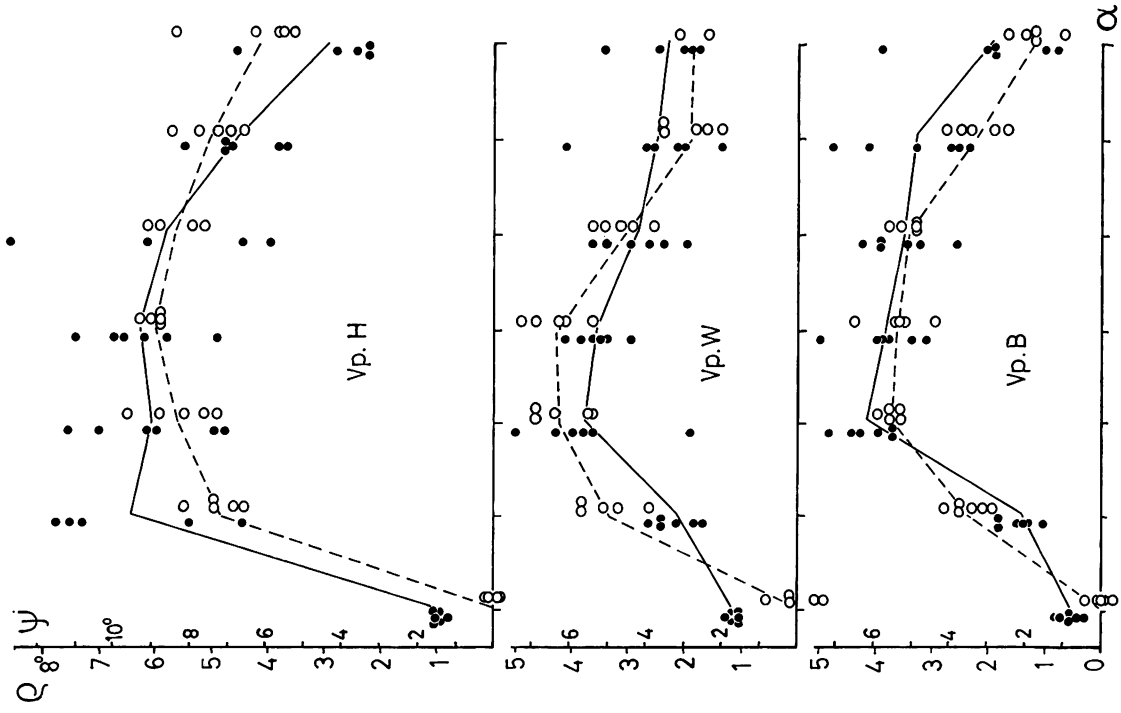

Fig. 11

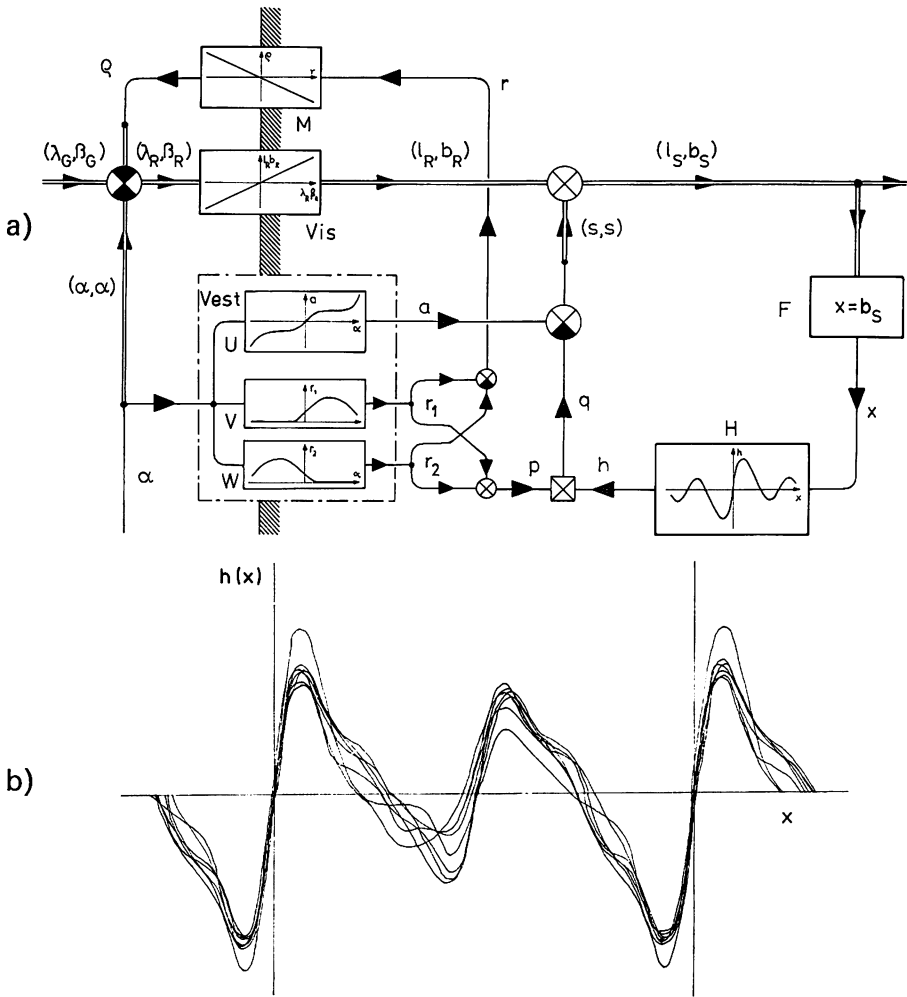

Fig. 12. a) Model of optic-vestibular orientation to the vertical. From BISCHOF and SCHEERER (1970). Double arrows represent two-component variables. Crossed square is multiplication symbol. For the remaining graphic symbols see the legends of Figs. 1 and 3. M : oculomotor system; Vis : visual system; $Vest$: vestibular system, split up into three subsystems U , V and W , which can be distinguished functionally but must not necessarily be anatomically different. (λ_G, β_G) : distal stimulus field, described by the inclination of light beam (λ) and of primary axis of the striped field (β) with respect to gravity (subscript G). (λ_R, β_R) : corresponding proximal stimulus field in retinal coordinates (subscript R), resulting from (λ_G, β_G) by componentwise subtraction of head inclination (a) and eye countertorsion (ρ). (l_R, b_R) : corresponding visual afference, operationally defined as a linear mapping of (λ_R, β_R) . (l_S, b_S) : apparent inclination of light beam and striped field, issuing from (l_R, b_R) by componentwise addition of a compensatory variable (s, s) . The latter can also be understood to act like a subjective frame of reference (subscript S) into which (l_R, b_R) is mapped to yield apparent contour inclinations. According to the model, s results from *arithmetic* averaging of vestibular and optic direction cues, i.e., from a linear superposition of the vestibular tilt signal a (equivalent to s in Fig. 3) and a quantity q which itself is a product of a vestibular weight factor p and an optical induction component h . The factor p is operationally measured by the average range of oscillation ψ as plotted in Fig. 11. It derives from the *addition* of two vestibular outputs r_1 and r_2 , each of which reacts sinusoidally to head tilt to one side. The *difference* of r_1 and r_2 results in a command (r) for eye countertorsion (ρ). The apparent inclinations (l_S, b_S) of the contours in the optic field are "filtered" by a mechanism F producing a quantity x which

The authors take this correlation as an indication that the optic-vestibular weight ratio as defined by them might be more than an arbitrary construction, and might refer to an actually existing physiological variable.⁵

Only in the upright position ($\alpha = 0^\circ$) is there a significant difference between the two curves in Fig. 11, the countertorsion being zero in this case (and changing sign for negative abscissa values), whereas the mean range of oscillation does not vanish entirely (and remains positive when the body is inclined counterclockwise). This discrepancy is accounted for by BISCHOF and SCHEERER (*loc. cit.*) as being the effect of the subtraction or addition, respectively, of two separate otolith output components, one of which signals clockwise, the other counterclockwise head inclinations (for this distinction, cf. also MILLER, 1962, 1966, 1970; TERINS, 1971).

Relying upon these assumptions and on systems-analytic elaborations previously cited, BISCHOF and SCHEERER summarize their theory about optic-vestibular interaction in human perception of verticality in the flow diagram of Fig. 12. Because obtained from the investigation of only a limited number of subjects, this model can only claim the status of a preliminary hypothesis, the confirmation or refinement of which must be left to further research.

References

- ADRIAN, E. D.: Discharges from vestibular receptors in the cat. *J. Physiol. (Lond.)* **101**, 389 (1942).
- ALEXANDER, G., BARANY, R.: Psychophysiologische Untersuchungen über die Bedeutung des Statolithenapparates für die Orientierung im Raume an Normalen und Taubstummen, nebst Beiträgen zur Orientierung mittels taktiler und optischer Empfindungen. *Z. Psychol.* **37**, 312–362; 414–456 (1904).
- ARNDTS, F.: Zur Frage nach der Lagewahrnehmung dienenden Sinnesfunktionen. *Pflügers Arch. ges. Physiol.* **204**, 539–540 (1924).
- ASCH, S. E., WITKIN, H. A.: Studies in space orientation. I. Perception of the upright with displaced visual fields. *J. exp. Psychol.* **38**, 325 (1948a).
- ASCH, S. E., WITKIN, H. A.: Studies in space orientation. II. Perception of the upright with displaced visual fields and with body tilted. *J. exp. Psychol.* **38**, 455 (1948b).
- ATTNEAVE, F.: Some informational aspects of visual perception. *Psychol. Rev.* **61**, 183–193 (1954).
- AUBERT, H.: Eine scheinbare bedeutende Drehung von Objekten bei Neigung des Kopfes nach rechts oder links. *Virchows Arch.* **20**, 381–393 (1861).
- BECK, K.: Untersuchungen über den statischen Apparat von Gesunden und Taubstummen. *Z. Psychol.* **46**, 362–378 (1912).
- BENDER, M. B., JUNG, R.: Abweichungen der subjektiven optischen Vertikalen bei Gesunden und Hirnverletzten. *Arch. Psychiat. Nervenkr.* **181**, 193–212 (1948).
- BENJAMINS, C. E., HUIZINGA, E.: Untersuchungen über die Funktion des Vestibularapparates bei der Taube. *Pflügers Arch. ges. Physiol.* **217**, 105 (1927).

⁵ Interpretable perhaps as the output of the utricles, which, due to their anatomical site, should yield afferent messages roughly proportional to the sine of head tilt (cf. VON HOLST, 1950).

equals the apparent inclination of the striped field's primary axis. The optical induction quantity h , then, is a periodic function of x . b) The model predicts that *one single* function $h(x)$ may be calculated from *any* given curve in Fig. 6 (see p. 170–171) by: 1. reassigning the ordinate values to the oblique co-ordinate system consisting of the diagonals and the abscissa in Fig. 6; 2. normalizing the transformed curve to the mean oscillation level; 3. dividing the resulting curve through its mean range of oscillation. Fig. 12b shows that this prediction is valid. Drawn are 6 curves calculated as described above from the mean-value curves for one Subject at 6 different body tilts. As is apparent, one single empirical curve $h(x)$ results. When $h(x)$ is inserted in block H in Fig. 12a, theoretical λ_C -values yielding a permanent $I_S = 0$ can be computed; they are shown in white in Fig. 6

- BENSON, A.J., BODIN, M.A.: Effect of orientation to the gravitational vertical on nystagmus following rotation about a horizontal axis. *Acta oto-laryng.* (Stockh.) **61**, 517 (1966).
- BERITOFF, J.S.: Spatial orientation of man and animals. 22. Int. Kongr. Physiol. Sci. Excerpta Med. Int. Congr. Ser. **47**, 3 (1962).
- BERITOFF, J.S.: Les mechanisme nerveux de l'orientation spatiale chez l'homme. *Neuropsychologia* **1**, 233 (1963).
- BERTINI, M.: Studio sulla natura dell'effeto "frame" nella percezione della verticale. *Riv. Psicologia* **58**, 1-35 (1964).
- BISCHOF, N.: Erkenntnistheoretische Grundlagenprobleme der Wahrnehmungspsychologie. In: *Handbuch der Psychologie*, Bd. 1/I, Bewußtsein und Wahrnehmung. W. METZGER and H. ERKE, Eds. pp. 21-78. Göttingen: Verlag f. Psychologie 1966a.
- BISCHOF, N.: Psychophysik der Raumwahrnehmung. *Ibid.* P. 307-408, 1966b.
- BISCHOF, N.: Stellungs-, Spannungs- und Lagewahrnehmung. *Ibid.* P. 409-497, 1966c.
- BISCHOF, N., SCHEERER, E.: Systemanalyse der optisch-vestibulären Interaktion bei der Wahrnehmung der Vertikalen. *Psychol. Forsch.* **34**, 99-181 (1970).
- BITTERMANN, M.E., WORCHEL, P.: The phenomenological vertical and horizontal in blind and sighted subjects. *Amer. J. Psychol.* **66**, 588 (1953).
- BORING, E.G.: Visual perception as invariance. *Psychol. Rev.* **59**, 141. The Gibsonian visual field. *Psychol. Rev.* **59**, 246 (1952).
- BRAEMER, W.: Verhaltensphysiologische Untersuchungen am optischen Apparat bei Fischen. *Z. vergl. Physiol.* **39**, 374-398 (1957).
- BRAEMER, W.: A critical review of the sun-azimuth hypothesis. *Cold Spr. Harb. Symp. quant. Biol.* **15**, 413 (1960).
- BRANDT, U., FLUUR, E.: Postural perceptions and compensatory displacements of the eye in respect to a presented force field. *Acta oto-laryng.* (Stockh.) **62**, 252-264 (1966).
- BRANDT, U., FLUUR, E.: Postural perceptions and eye displacements during the variation of a force field acting in the midfrontal plane. *Acta oto-laryng.* (Stockh.) **63**, 49-64 (1967).
- BRECHER, G.A., SCHUBERT, G.: Über optische Lokalisation und Augenstellung bei Vor-Rückwärtsneigung oder exzentrischer Rotation des Körpers. *Z. Sinnesphysiol.* **65**, 1 (1934).
- BROWN, L.: Orientation to the vertical during water immersion. *Aerospace Med.* **32**, 209-217 (1961).
- BRUNSWIK, E.: *Wahrnehmung und Gegenstandswelt*. Leipzig, Wien: Deuticke 1934.
- BRUNSWIK, E.: Thing constancy as measured by correlation coefficients. *Psychol. Rev.* **47**, 68 (1940).
- BRUNSWIK, E.: *Perception and the representative design of psychological experiments*. Berkeley: University of California Press 1956.
- BRUNSWIK, E., KARDOS, L.: Das Duplizitätsprinzip in der Theorie der Farbenwahrnehmung. *Z. Psychol.* **111**, 315 (1929).
- BÜHLER, K.: *Die Erscheinungsweisen der Farben*. Jena: 1922.
- CARPENTER, R.H.S., BLAKEMORE, C.: Interactions between orientations in human vision. *Exp. Brain Res.* **18**, 287-303 (1973).
- CLARK, B., GRAYBIEL, A.: Perception of the visual horizontal in normal and labyrinthine defective subjects during prolonged rotation. *Amer. J. Psychol.* **79**, 608-612 (1966a).
- CLARK, B., GRAYBIEL, A.: Factors contributing to the delay in the perception of the oculogravic illusion. *Amer. J. Psychol.* **79**, 377-388 (1966b).
- COLENBRANDER, A.: Eye and otoliths: A centrifuge study on the ocular response to otolith stimulation. *Aeromed. Acta* (Soesterberg) **9**, 45-91 (1963-1964).
- COLTHEART, M.: Visual feature-analyzers and after-effects of tilt and curvature. *Psychol. Rev.* **78**, 114-121 (1971).
- CORREIA, M.J., GUEDRY, F.E.: Influence of labyrinth orientation relative to gravity on responses elicited by stimulation of the horizontal semicircular canals. U.S. Naval School of Aviat. Med. N.A.S.A. joint report, Pensacola, Fla., 1964.
- CORREIA, M.J., HIXSON, W.C., NIVEN, J.: Otolith shear and the visual perception of force direction. Discrepancies and a proposed resolution. Nami-951, Nasa Order R-93. Pensacola, Fla: Naval Aerospace Med. Inst., 1965.
- CULBERT, S.S.: Directional after-effects following systematic distortion of the visual field. *J. Psychol.* (Provincetown) **37**, 81-93 (1954).

- CURRAN, C.R., LANE, H.L.: On the relation of some factors that contribute to estimates of verticality. *J. exp. Psychol.* **64**, 295 (1962).
- DAY, R.H., WADE, N.J.: The reference for visual normalization. *Amer. J. Psychol.* **82**, 191-267 (1969).
- DERWORT, A.: Über vestibulär induzierte Dysmorphopsien. *Dtsch. Z. Nervenheilk.* **170**, 295-325 (1953).
- DUNCKER, K.: Über induzierte Bewegung. *Psychol. Forsch.* **12**, 180 (1929).
- FISCHER, M.H.: Messende Untersuchungen über die Gegenrollung des Auges und die Lokalisation der scheinbaren Vertikalen bei seitlicher Neigung des Kopfes, des Stammes und des Gesamtkörpers. I. Neigungen bis zu 40°. *Graefes Archiv* **118**, 633-680 (1927).
- FISCHER, M.H.: Messende Untersuchungen über die Gegenrollung der Augen und die Lokalisation der scheinbaren Vertikalen bei seitlicher Neigung des Gesamtkörpers bis zu 360°. II. Untersuchungen an Normalen. *Graefes Archiv* **123**, 476-508 (1930a).
- FISCHER, M.H.: III. Untersuchungen an einem Ertaubten mit Funktionsuntüchtigkeit beider Vestibularapparate und einem einseitig Labyrinthlosen. *Graefes Archiv* **123**, 509-531 (1930b).
- FLUUR, E., MELLSTRÖM, A.: Utricular stimulation and oculomotor reactions. *Laryngoscope (St. Louis)* **53**, 1701-1712 (1970a).
- FLUUR, E., MELLSTRÖM, A.: Saccular stimulation and oculomotor reactions. *Laryngoscope (St. Louis)* **53**, 1713-1721 (1970b).
- GARTEN, S.: Über die Grundlagen unserer Orientierung im Raum. *Abh. Math. Phys. Klasse, Sächs. Akad.* **36**, 431 (1920).
- GEISSLER, H.G.: Zur Analyse adaptiver Prozesse bei der Orientierung im Raum. *Z. Psychol.* **171**, (1965).
- GELB, A.: Die psychologische Bedeutung pathologischer Störungen der Raumwahrnehmungen. *Ber. 9. Kongr. f. exp. Psychol. München. Jena* 23-80, 1926.
- GIBSON, J.J.: Adaptation, after-effect, and contrast in the perception of tilted lines. II. Simultaneous contrasts and the areal restriction of the after-effect. *J. exp. Psychol.* **20**, 553-569 (1937a).
- GIBSON, J.J.: Adaptation with negative after-effects. *Psychol. Rev.* **44**, 222-244 (1937b).
- GIBSON, J.J.: The perspective of the visual world. Boston: Houghton Mifflin Comp. 1950.
- GIBSON, J.J.: The relation between visual and postural determinants of the phenomenal vertical. *Psychol. Rev.* **59**, 370-375 (1952).
- GIBSON, J.J.: The visual perception of objective motion and subjective movement. *Psychol. Rev.* **61**, 304 (1954).
- GIBSON, J.J.: The senses considered as perceptual systems. Boston: Houghton Mifflin Comp. 1966.
- GIBSON, J.J., MOWRER, O.H.: Determinants of the perceived vertical and horizontal. *Psychol. Rev.* **45**, 300 (1938).
- GIBSON, J.J., RADNER, M.: Adaptation, after-effect and contrast in the perception of tilted lines. *J. exp. Psychol.* **20**, 452-467; 553-569 (1937).
- GIROTTI, G.: La percezione dello spazio in rapporto alla neuropatologia. I. Determinazione della verticale visiva e del vertice acustico. *Arch. Psicol. Neurol. Psychiat.* **24**, 175-336 (1963).
- GIROTTI, G., BORDOGNA, A.: La determinazione della verticale e del piano mediano visivi nelle compressioni vestibulari. *Riv. Psicologia* **57**, 301-339 (1963).
- GRAYBIEL, A., CLARK, B.: Perception of the horizontal or vertical with head upright, on the side, and inverted under static conditions, and during exposure to centripetal force. *Aerospace Med.* **33**, 147-155 (1962).
- GRAYBIEL, A., MILLER, E.F. II, NEWSOM, B.D., KENNEDY, R.S.: The effect of water immersion on perception of the oculogravic illusion in normal and labyrinthine-defective subjects. *Acta oto-laryng. (Stockh.)* **65**, 599-610 (1968).
- GREENBERG, G.: Visual induction of eye torsion, as measured with an after-image technique, in relation to visual perception of the vertical. Ph.D. Diss. Duke Univ., 1960.
- GUEDRY, F.E.: Orientation of the rotation-axis relative to gravity: its influence on nystagmus and the sensation of rotation. *Acta oto-laryng. (Stockh.)* **60**, 30 (1965).
- HALPERN, L.: Sensorimotor induction in disturbed equilibrium. *Arch. Neurol. Psychiat. (Chic.)* **62**, 330-354 (1949).

- HASEGAWA, T.: Labyrinthreflexe nach Abschleuderung der Otolithenmembranen. *Pflügers Arch. ges. Physiol.* **236**, 589 (1935).
- HOFMANN, F. B.: Über den Einfluß schräger Konturen auf die optische Lokalisation bei seitlicher Kopfneigung. *Pflügers Arch. ges. Physiol.* **136**, (1910).
- HOFMANN, F. B., BIELSCHOWSKY, A.: Über die Einstellung der scheinbaren Horizontalen und Vertikalen bei Betrachtung eines von schrägen Konturen erfüllten Gesichtsfeldes. *Pflügers Arch. ges. Physiol.* **126**, 453-475 (1909).
- HOLST, E. VON: Quantitative Untersuchungen über Umstimmungsvorgänge im Zentralnervensystem. I. Der Einfluß des "Appetits" auf das Gleichgewichtsverhalten bei *Pterophyllum*. *Z. vergl. Physiol.* **31**, 134 (1948).
- HOLST, E. VON: Die Arbeitsweise des Statolithenapparates bei Fischen. *Z. vergl. Physiol.* **32**, 60-120 (1950).
- HOLST, E. VON, GRIESEBACH, E.: Einfluß des Bogengangssystems auf die "subjektive Lotrechte" beim Menschen. *Naturwissenschaften* **38**, 67-68 (1951).
- HOLST, E. VON, MITTELSTAEDT, H.: Das Reafferenzprinzip. *Naturwissenschaften* **37**, 464 (1950).
- HOWARD, I. P., TEMPLETON, W. B.: The effect of steady fixation on the judgement of relative depth. *J. exp. Psychol.* **16**, 193-203 (1964a).
- HOWARD, I. P., TEMPLETON, W. B.: Visually-induced eye torsion and tilt adaptation. *Vision Res.* **4**, 433-437 (1964b).
- HOWARD, I. P., TEMPLETON, W. B.: Human spatial orientation. New York: Wiley 1966.
- HUBEL, D. H., WIESEL, T. N.: Receptor fields of single neurons in the cat's striate cortex. *J. Physiol. (Lond.)* **148**, 574 (1959).
- HUIZINGA, E.: The physiological and clinical importance of experimental work on the pigeon's labyrinth. *J. Laryng.* **69**, 260 (1955).
- JONGKEES, L. B. W.: On the function of the sacule. *Acta oto-laryng. (Stockh.)* **38**, 18-26 (1950).
- JONGKEES, L. B. W.: Some remarks on the function of the vestibular organ. *Reports of the Institute of Laryng. Otol.* **2**, 1 (1952).
- KARDOS, L.: Dingfarbenwahrnehmung und Duplizitätstheorie. *Z. Psychol.* **108**, 240 (1928).
- KARDOS, L.: Die "Konstanz" phänomenaler Dingmomente. In: E. BRUNSWIK Ed. *Beiträge zur Problemgeschichte der Psychologie (Bühler-Festschrift)*. Jena: 1929.
- KELLOGG, R. S.: Dynamic counterrolling of the eye in normal subjects and in persons with bilateral labyrinthine defects. *NASA Sp-77*, 195-202 (1965).
- KLEINT, H.: Versuche über die Wahrnehmung. *Z. Psychol.* **138**, 1 (1936); **140**, 109 (1937); **141**, 9 (1937); **142**, 259 (1938); **143**, 299 (1938); **148**, 145 (1940); **149**, 31 (1940).
- KLIX, F.: Elementaranalysen zur Psychophysik der Raumwahrnehmung. VEB Dtsch. Verlag d. Wissensch., Berlin, 1962.
- KLOPP, H. W.: Über die Entwicklung und den Abbau des aufrechten Bildes. *Fortschr. Neurol. Psychiat.* **24**, 27 (1956).
- KÖHLER, W., WALLACH, H.: Figural after-effects. *Proc. Amer. Phil. Sci.* **88**, 269-357 (1944).
- KOFFKA, K.: Principles of Gestalt Psychology. Routledge and Kegan Paul: London, 1935.
- KOHLER, I.: Über Aufbau und Wandlungen der Wahrnehmungswelt. *Sitzber. Österr. Akad. Wiss.* **227**, Wien, 1951.
- KOHLER, I.: Ungewöhnung im Wahrnehmungsbereich. *Die Pyramide* **3**, 92 (1953).
- KOHLER, I.: Interne und externe Organisation in der Wahrnehmung. *Psychol. Beitr.* **6**, 426 (1961).
- LINSCHOTEN, J.: Experimentelle Untersuchung der sogenannten induzierten Bewegung. *Psychol. Forsch.* **24**, 34-92 (1952).
- LOWENSTEIN, O.: Labyrinth and equilibrium. In: *Physiol. Mechanisms in Animal Behav. Soc. exp. Biol. Symp. IV*. Cambridge: Univ. Press 1950.
- LOWENSTEIN, O., ROBERTS, T. D. M.: The equilibrium function of the otolith organs of the Thornback Ray (*Raja clavata*). *J. Physiol. (Lond.)* **110**, 392 (1950).
- LORENZ, K.: Gestaltwahrnehmung als Quelle wissenschaftlicher Erkenntnis. *Z. exp. angew. Psychol.* **6**, 118 (1959).
- MACCORQUODALE, K., MEEHL, P. E.: On a distinction between hypothetical constructs and intervening variables. *Psychol. Rev.* **55**, 95-107 (1948).
- McFARLAND, J. H., CLARKSON, F.: Perception of orientation: Adaptation to lateral body-tilt. *Amer. J. Psychol.* **79**, 265-271 (1966).

- MACKEY, D.M.: Cerebral organization and the conscious control of action. In: *Brain and conscious experience*. J.C. ECCLES, Ed. pp. 422-445, Berlin-Heidelberg-New York: Springer 1966.
- MCNALLY, W.J.: Five lectures on the physiology of the ear. *Ann. Otol.* **38**, 1180 (1929).
- MAGNUS, R.: *Körperstellung*. Berlin: Springer 1924.
- MANN, C.W.: Visual factors in the perception of verticality. *J. exp. Psychol.* **44**, 460-464 (1952a).
- MANN, C.W.: An analysis of the oculogyral effect. *J. Aviat. Med.* **23**, 246-253 (1952b).
- MAXWELL, S.S.: *Labyrinth and Equilibrium*. Philadelphia-London: 1923.
- METZGER, W.: Zur anschaulichen Repräsentation von Rotationsvorgängen und ihre Deutung durch Gestaltkreislehre und Gestalttheorie. *Z. Sinnesphysiol.* **68**, 261 (1940).
- METZGER, W.: *Psychologie*. Darmstadt: Steinkopff 1954²; 1968³.
- MEYER ZUM GOTTESBERGE, A., PLESTER, D.: Nachweis der statischen Funktion des Sacculus beim Menschen. *Arch. Ohr., Nas., u. Kehlk.-Heilk.* **185**, 254-258 (1965).
- MILLER, E.F.II.: Counter-rolling of the human eyes produced by head tilt with respect to gravity. *Acta oto-laryng.* (Stockh.) **54**, 479-501 (1962).
- MILLER, E.F.II.: Ocular counter-rolling. In: R.J. WOLFSON, Ed. *The vestibular system and its diseases*. Philadelphia: Univ. of Pennsylvania Press, 229-241, 1966.
- MILLER, E.F.II.: Evaluation of otolith organ function by means of ocular counter-rolling measurements. In: J. STAHL, Ed. *Vestibular function on earth and in space*. Oxford: Pergamon Press, 97-111, 1970.
- MILLER, E.F.II., GRAYBIEL, A.: A comparison of ocular counter-rolling movements between normal persons and deaf subjects with bilateral labyrinthine defects. *Ann. oto-rhino-laryng.* **72**, 885 (1963).
- MILLER, E.F.II., GRAYBIEL, A.: Role of the otolith organs in the perception of horizontality. *Amer. J. Psychol.* **79**, 24-37 (1966).
- MITTELSTAEDT, H.: The analysis of behavior in terms of control systems. In: B. SCHAFFNER, Ed. *Group Processes*. Transactions of the 5. Conf. of the J. Macy Found. New York 45, 1960.
- MITTELSTAEDT, H.: Basic solutions to a problem of angular orientation. In: R.F. REISS, Ed. *Neural Theory and Modeling*, 259-272. Stanford Univ. Press 1964.
- MITTELSTAEDT, H.: Grundprobleme der Analyse von Orientierungsleistungen. *Jahrb. d. Max-Planck-Ges.* p. 121, 1966.
- MORANT, R.B., ARONOFF, J.C.: Starting position, adaptation, and visual framework as influencing the perception of verticality. *J. exp. Psychol.* **71**, 684-686 (1966).
- MORANT, R.B., BELLER, H.K.: Adaptation to prismatically rotated visual fields. *Science* **148**, 530 (1965).
- MORANT, R.B., HARRIS, J.: Two different aftereffects of exposure to visual tilts. *Amer. J. Psychol.* **78**, 218-226 (1965).
- MORANT, R.B., MISTOVICH, M.: Tilt after-effects between the vertical and horizontal axes. *Percept. Mot. Skills* **10**, 75-81 (1960).
- MÜLLER, G.E.: Über das Aubertsche Phänomen. *Z. Sinnesphysiol.* **49**, 109-246 (1916).
- NAYLOR, G.F.: Effects of stress on the perception of direction. *Australian J. Psychol.* **15**, 17-28 (1963).
- NAYLOR, G.F.K.: Subjective judgements of the vertical: An estimate of their nature and consistency. *Australian J. Psychol.* **17**, 188-192 (1965).
- OHWAKI, S.: An investigation of figural adaptation: a study within the framework of sensory-tonic field theory. *Amer. J. Psychol.* **74**, 3-16 (1961).
- OPPENHEIMER, E.: Optische Versuche über Ruhe und Bewegung. *Psychol. Forsch.* **20**, 1-46 (1935).
- PASSEY, G.E.: The perception of the vertical. IV. Adjustment to the vertical with normal and tilted visual frames of references. *J. exp. Psychol.* **40**, 738-745 (1950).
- PERLMAN, H.B.: The sacculle, observations from a differentiated reinforced area of the saccular wall in man. *Acta oto-laryngol.* (Stockh.) **32**, 678 (1940).
- QUIX, F.H., EIJVOGEL, M.H.: Experimente über die Funktion des Otolithenapparates beim Menschen. *Z. Hals-, Nas.- u. Ohrenheilk.* **23**, 68-96 (1929).

- SCHÖNE, H.: Über den Einfluß der Schwerkraft auf die Augenrollung und auf die Wahrnehmung der Lage im Raum. *Z. vergl. Physiol.* **46**, 57–87 (1962).
- SCHÖNE, H.: On the Role of gravity in human spatial orientation. *Aerospace Med.* **35**, 764 (1964).
- SCHÖNE, H., PARKER, D.E.: Inversion of the effect of increased gravity on the subjective vertical. *Naturwissenschaften* **54**, 288–289 (1967).
- SCHÖNE, H., PARKER, D.E., MORTAG, H.G.: Subjective vertical as a function of body position and gravity magnitude. *Naturwissenschaften* **54**, 288 (1967).
- SCHÖNE, H., UDO DE HAES, H.: Perception of gravity-vertical as a function of head and trunk position. *Z. vergl. Physiol.* **60**, 440–444 (1968).
- SCHÖNE, H., UDO DE HAES, H.: Space orientation in humans with special reference to the interaction of vestibular, somesthetic and visual inputs. *Biokybernetik* **3**, 172–191 (1971).
- SCHNEIDER, C.W., BARTLEY, S.H.: A study of the effects of mechanically induced tension of the neck muscles on the perception of verticality. *J. Psychol. (Provincetown)* **54**, 245–248 (1962).
- STIGLER, R.: Versuche über die Beteiligung der Schwereempfindung an der Orientierung des Menschen im Raume. *Pflügers Arch. ges. Physiol.* **148**, 573–584 (1912).
- SUTHERLAND, N.S.: Figural after-effects and apparent size. *Quart. J. exp. Psychol.* **13**, 222–228 (1961).
- SZENTÁGOTAI, J.: Die Rolle der einzelnen Labyrinthrezeptoren bei der Orientation von Augen und Kopf im Raume. Budapest: Akadémiai Kiadó 1952.
- TAIT, J.: Is all hearing cochlear. *Ann. Otol. (St. Louis)* **41**, 681 (1932).
- TERINS, J.: Counter-rolling of the eyes in some unilateral vestibular disorders. In: J. STAHL, Ed. *Vestibular function on earth and in space*. Oxford: Pergamon Press, 109–113, 1971.
- UDO DE HAES, H.: Stability of apparent vertical and ocular counter-torsion as a function of lateral tilt. *Perception & Psychophysics* **8**, 137–142 (1970).
- UDO DE HAES, H., SCHÖNE, H.: Interaction between statolith organs and semicircular canals on apparent vertical and nystagmus. *Acta oto-laryng. (Stockh.)* **69**, 25–31 (1970).
- VERNON, M.D.: The perception of inclined lines. *Brit. J. Psychol.* **25**, 186 (1935).
- VERSTEEGH, L.: Ergebnisse partieller Labyrinthexstirpation bei Kaninchen. *Acta oto-laryng. (Stockh.)* **11**, 393 (1927).
- WALSH, E.G.: Perception of linear motion following unilateral labyrinthectomy: variation of threshold according to the orientation of the head. *J. Physiol. (Lond.)* **153**, 350 (1960).
- WALSH, E.G.: Role of the vestibular apparatus in the perception of motion on a parallel swing. *J. Physiol. (Lond.)* **155**, 506 (1961).
- WERNER, H., WAPNER, S., CHANDLER, K.A.: Experiments on sensory-tonic field theory of perception. II. Effect of supported and unsupported tilt of the body on the visual perception of verticality. *J. exp. Psychol.* **42**, 346 (1951).
- WERTHEIMER, M.: Experimentelle Studien über das Sehen von Bewegung. *Z. Psychol.* **61**, 161–265 (1912).
- WITKIN, H.A.: The nature and importance of individual differences in perception. *J. Personality* **18**, 145 (1949a).
- WITKIN, H.A.: Sex differences in perception. *Trans. N.Y. Acad. Soc.* **12**, 22 (1949b).
- WITKIN, H.A., ASCH, S.E.: Studies in space orientation. III. Perception of the upright in the absence of a visual field. *J. exp. Psychol.* **38**, 603 (1948a).
- WITKIN, H.A., ASCH, S.E.: Studies in space orientation. IV. Further experiments on perception of the upright with displaced visual fields. *J. exp. Psychol.* **38**, 762 (1948b).
- WITKIN, H.A., LEWIS, H.B., HERTZMAN, M., MACHOVER, K., MEISSNER, P.B., WAPNER, S.: *Personality through perception*. New York: Harper 1954.
- WOELLNER, R.C., GRAYBIEL, A.: Counterrolling of the eyes and its dependence on the magnitude of gravitational or inertial force acting laterally on the body. *J. appl. Physiol.* **14**, 632–634 (1959).
- WOOD, R.W.: The "haunted-swing" illusion. *Psychol. Rev.* **2**, 277–278 (1895).
- YOUNG, H.H.: Personality test correlates of orientation to the vertical: A test of Witkin's Field dependency hypothesis. *J. abnorm. soc. Psychol.* **59**, 188–192 (1959).
- YOUNG, H.H., MEIRL, J.L.: A revised dynamic otolith model. *Aerospace Med.* **39**, 606–608 (1968).

Author Index

Page numbers in *italics* refer to the bibliography

- | | | |
|---|---|---|
| <p>Aarons, L., s. Lachman, J. 365, 367</p> <p>Abels, H. 369, 370, 383, 425, 443</p> <p>Abend, W. K., s. Fernández, C. 532, 575</p> <p>Ackerman, U., Johnson, W. H., Thomas, E. L. 399, 402</p> <p>Ades, H. W., s. Engström, H. 70, 142</p> <p>Ades, H. W., s. Gernandt, B. 434, 445</p> <p>Ades, H., s. Mickle, W. 7, 8, 149</p> <p>Adey, W. R., Kado, R. T., Rhodes, J. M. 261, 263</p> <p>Adrian, E. D. 69, 71, 136, 165, 185, 285, 315, 423, 443, 452, 454, 460, 464, 484, 517, 573</p> <p>Ajuriaguerra, J. de, s. Hécaen, H. 218, 230</p> <p>Akert, K., s. Scollo-Lavizzari, G. 612, 620</p> <p>Albe-Fessard, D., Donaldson, J. M. L. 609, 615</p> <p>Alden, F. D., Horton, M. O., Caldwell, G. M. 357</p> <p>Alessi, D. 213, 229</p> <p>Alexander, G., Bárány, R. 164, 185, 435, 443</p> <p>Alexander, S. J., Cotzin, M., Hill, C. J., Jr., Ricciuti, E. A., Wendt, G. R. 262, 263</p> <p>Alltucker, D. S., s. Gualtierotti, T. 452, 461, 464, 486</p> <p>Ambler, R. K., Guedry, F. E. 126, 136</p> <p>Ambler, R. K., s. Guedry, F. E. 116, 126, 129, 130, 131, 144</p> <p>Ambler, R. K., s. Mann, C. W. 85, 148</p> <p>Ames, A. 566, 573</p> <p>Anderson, A., s. Henriksson, N. G. 36, 145</p> <p>Andersson, S., Gernandt, B. 7, 136</p> <p>Andersson, S., Nilsson, A., Ruuth, E., Smith, G. 36, 110, 136</p> | <p>Angyal, A., Blackman, N. 365, 366</p> <p>Ansom, B. J. 573</p> <p>Aoki, M., s. Tokita, T. 355</p> <p>Aoki, S., s. Tokita, T. 355</p> <p>Aokia, S., s. Fukuda, T. 376, 377, 385</p> <p>Arlaschenko, N. I., Bokhov, B. B., Busygin, V. Ye., Volokhova, N. A., Grigoryev, Yu. G., Polyakov, B. I., Farber, Yu. V. 353</p> <p>Arndts, F. 88, 136, 164, 185</p> <p>Arnoult, M. 22, 136</p> <p>Aronoff, J. C., s. Morant, R. B. 160, 189</p> <p>Aronson, L., s. Spiegel, E. A. 477, 489</p> <p>Arslan, M. 222, 229</p> <p>Arslan, M., Molinari, J. A. 8, 136, 475, 484</p> <p>Arx, S. V., s. Pfaltz, C. R. 378, 387</p> <p>Asch, S. E., Witkin, H. A. 160, 162, 185</p> <p>Asch, S. E., s. Witkin, H. A. 160, 162, 182, 190</p> <p>Aschan, G. 376, 379, 383, 406, 409, 410, 419, 425, 426, 443</p> <p>Aschan, G., Bergstedt, M. 62, 136, 419, 443</p> <p>Aschan, G., Bergstedt, M., Goldberg, L. 307, 315</p> <p>Aschan, G. M., Bergstedt, M., Goldberg, L., Laurell, L. 307, 315</p> <p>Aschan, G., Bergstedt, M., Stahle, J. 200, 229</p> <p>Aschan, G., Finer, B. L., Hagbarth, K. E. 365, 366</p> <p>Aschan, G., Nylén, C. O., Stahle, J., Wersäll, R. 29, 136, 429, 430, 443</p> <p>Aschan, G., s. Grant, G. 205, 230</p> <p>Aschoff, J. C. 217, 229</p> <p>Aschoff, J. C., Cohen, B. 587, 597, 598, 615</p> | <p>Aschoff, J. C., Conrad, B., Kornhuber, H. H. 199, 208, 210, 229, 587, 606, 615</p> <p>Aschoff, J. C., s. Kornhuber, H. H. 600, 602, 610, 618</p> <p>Atema, J., s. Von Baumgarten, R. J. 558, 559, 560, 580</p> <p>Attneave, F. 166, 185</p> <p>Atwood, R. P., s. Braitenberg, V. 604, 615</p> <p>Aubert, H. 82, 86, 136, 160, 161, 185, 241, 263</p> <p>Aubert, H., Delage, Y. 408, 410, 418, 419, 433, 443</p> <p>Aubry, M., s. Claude, H. 361, 365, 366</p> <p>Austin, G. M., s. McCouch, G. P. 459, 461</p> <p>Auxter, D. M. 357</p> <p>Azzena, G. B. 460, 460, 470, 481, 484</p> <p>Azzena, G. B., Giretti, M. L., Deriu, P. L. 475, 484</p> <p>Babinski, J., Weill, G. A. 272, 278</p> <p>Babiyak, V. P., s. Kurashvili, A. Ye. 303, 318</p> <p>Babkin, B. P. 400</p> <p>Babkin, B. P., Bornstein, M. B. 400, 402</p> <p>Babkin, B. P., Divorkin, S. 400, 402</p> <p>Babskii, E. B., Gurfinkel, V. S., Romel, E. L. 359</p> <p>Bach, L. 361, 366</p> <p>Bader, W., Kornhuber, H. H. 222, 229, 587, 615</p> <p>Baker, A. B. 227, 229</p> <p>Baker, R. G., Mano, N., Shimazu, H. 458, 460</p> <p>Bakhvalova, T. D. 300, 315</p> <p>Baldenweck, L. 269, 271, 278</p> <p>Baldrighi, G., s. Von Baumgarten, R. J. 558, 559, 560, 580</p> <p>Bárány, J. W., Ismail, A. H., Manning, K. R. 359</p> |
|---|---|---|

- Bárány, R. 62, 93, 136, 220, 229, 269, 270, 271, 274, 276, 278, 303, 315, 353, 357, 361, 366, 369, 383, 405, 410, 415, 418, 421, 427, 444, 451, 460, 483, 484, 590, 615
- Bárány, R., Wittmaack, K. 270, 271, 278
- Bárány, R., s. Alexander, G. 164, 185, 435, 443
- Barber, H. O., Wright, G. 201, 206, 229, 365, 366
- Barbey, E. 353
- Barcroft, H., Edholm, O. G. 393, 402
- Bard, P. 610, 612, 615
- Bard, P., Orias, O. 610, 615
- Bard, P., Woolsey, C. N., Snider, R. S., Mountcastle, V. B., Bromiley, R. B. 607, 615
- Bard, P., s. Tyler, D. B. 389, 390, 391, 393, 404
- Barlow, J. S. 6, 7, 8, 90, 136, 495, 496, 500, 573
- Barnes, G. R. 75, 112, 115, 136, 290, 312, 315, 315
- Barnes, G. R., s. Benson, A. J. 111, 112, 137, 290, 311, 312, 316
- Barness, C. D., Pompeiano, O. 585, 615
- Barness, C. D., s. Pompeiano, O. 585, 619
- Barnothy, I. M., s. Torok, N. 220, 232
- Baron, J. 353
- Baron, J. B. 356
- Baron, J. B., s. Soulairac, A. 356
- Barré, J. A. 436, 444
- Barrera, S. E., s. Northington, P. 471, 472, 483
- Barrett, G. V., Thorton, C. L. 119, 136
- Barry, W., s. Melvill Jones, G. 45, 52, 53, 54, 148, 283, 296, 319
- Bartels, M. 211, 229
- Bartley, S., s. Graybiel, A. 25, 58, 143
- Bartley, S. H., s. Schneider, C. W. 163, 190
- Baruk, H., s. Claude, H. 361, 365, 366
- Bass, R. I. 353, 359
- Bass, R. L. 357
- Batini, C., Moruzzi, G., Pompeiano, O. 478, 481, 484
- Batini, C., Pompeiano, O. 478, 484
- Bauermeister, M. 85, 89, 94, 136, 241, 263
- Bauermeister, M., Werner, H., Wapner, S. 85, 136
- Von Baumgarten, R. J. 555, 567, 579, 580
- Von Baumgarten, R. J., Atema, J., Hukuhara, J., Rocker, M. 580
- Von Baumgarten, R. J., Baldrighi, G., Atema, J., Shillinger, G. L. 558, 559, 560, 580
- Bechinger, D., Kongehl, G., Kornhuber, H. H. 56, 58, 136
- Bechinger, D., Kongehl, G., Kornhuber, H. H., Walther, C. 594, 615
- Bechinger, D., Kriebel, J., Schlager, M. 196, 229
- Bechterew, W. von 451, 456, 460, 463, 464, 465, 466, 468, 471, 472, 479, 484
- Beck, K. 164, 185, 357
- Beck, O., Blach, P. 276, 278
- Becker, W. 588, 592, 594, 596, 615
- Becker, W., Deecke, L., Grözingler, B., Kornhuber, H. H. 601
- Becker, W., Fuchs, A. F. 591, 596, 615
- Becker, W., Hoehne, O., Iwase, K., Kornhuber, H. H. 600, 615
- Becker, W., Jürgens, R. 595, 615
- Becker, W., Klein, H. M. 199, 229
- Beckwith, F. D., s. Kennedy, R. S. 345, 352
- Beerens, A. J. J. 423, 444
- Begbie, G. H. 357
- Behr, K., Preber, L., Silfver skiold, D. F. 444
- Von Behrman, W. 304, 315
- Beischer, D. E., s. Graybiel, A. 575
- Beischer, D. E., s. Meek, J. C. 427, 448
- Von Békésy, G. 24, 25, 33, 34, 44, 68, 74, 75, 106, 153, 362, 366, 416, 427, 429, 432, 444
- Belanger, F., Mayne, R. 29, 137, 573
- Belanger, F., s. Mayne, R. 517, 521, 522, 530, 577
- Beller, H. K., s. Morant, R. B. 169, 189
- Bender, M. B., Jung, R. 162, 186
- Bender, M. B., Shanzer, S. 216, 217, 229, 590, 615
- Bender, M. B., Weinstein, E. A. 214, 229
- Bender, M. B., s. Cohen, B. 586, 616
- Bender, M. B., s. Pasik, P. 217, 232
- Benfari, R. C. 119, 137
- Benjamins, C. E., Huizinga, E. 165, 186
- Benson, A. J. 6, 14, 39, 42, 44, 45, 72, 111, 115, 123, 127, 137, 294, 295, 296, 297, 299, 300, 301, 310, 311, 312, 313, 314, 316, 378, 383, 550, 573
- Benson, A. J., Barnes, G. R. 111, 112, 137, 290, 311, 312, 316
- Benson, A. J., Bodin, M. 111, 112, 115, 118, 123, 137, 182, 186, 234, 256, 263, 288, 292, 293, 294, 295, 309, 310, 311, 316, 546, 550, 573
- Benson, A. J., Brand, J. L. 36, 137, 365, 366
- Benson, A. J., Diaz, E., Farrugia, P. 75, 111, 113, 137
- Benson, A. J., Goorney, A. B., Reason, J. T. 36, 137, 365, 366
- Benson, A. J., Guedry, F. E. 45, 53, 54, 113, 128, 137
- Benson, A. J., Guedry, F. E., Melvill Jones, G. 111, 112, 116, 137, 287, 288, 290, 316, 548, 549, 552, 553, 566, 567, 574
- Benson, A. J., Sternfeld 312
- Benson, A. J., Whiteside, T. C. D. 262, 263, 299, 300, 316, 550, 573
- Benson, A. J., s. Guedry, F. E. 128, 144
- Benson, A. J., s. Reason, J. T. 36, 150
- Bergmann, F., Gutman, J. 364, 366

- Bergstedt, M. 131, 137, 256, 263, 291, 300, 303, 304, 307, 316, 351, 561, 574
- Bergstedt, M., s. Aschan, G. 62, 136, 200, 229, 307, 315, 419, 443
- Bergstedt, M., s. Fregly, A. R. 347, 351
- Beritov, I. S. 8, 90, 137, 156, 186, 501, 574
- Berkeley 571
- Berman, A. J., s. Taub, E. 134, 152
- Berry, C. 393, 398, 402, 403
- Berry, C. A., Homick, G. L. 402, 402
- Berry, C. A., s. Graybiel, A. 103, 104, 143, 242, 244, 264
- Berry, N., s. Mann, C. W. 88, 147
- Berthelow-Berry, N. H., s. Mann, C. W. 84, 86, 88, 147
- Bertini, M. 160, 186
- Best, C. H., Taylor, N. B. 400, 403
- Bethe, A. 466, 484
- Bickford, R. G., s. Mahoney, J. L. 362, 367, 374, 386
- Bielschowsky, A., s. Hofmann, F. B. 160, 188
- Billingham, H. T. 554, 556, 574
- Billingham, J. 298, 316, 573
- Billingham, J., s. Graybiel, A. 103, 104, 143, 242, 244, 264
- Birren, J. E. 95, 137, 353, 357
- Birren, J. E., s. Fisher, M. B. 355, 358
- Bischof, N. 157, 158, 159, 160, 163, 165, 166, 177, 178, 186, 414, 444
- Bischoff, N., Scheerer, E. 117, 137, 159, 160, 161, 169, 170, 174, 176, 177, 178, 180, 182, 184, 185, 186
- Bittermann, M. E., Worchel, P. 162, 186
- Bizzi, E. 586, 612, 615
- Blach, P., s. Beck, O. 276, 278
- Blackburn, L. H., s. Cohen, M. M. 107, 140
- Blackman, N., s. Angyal, A. 365, 366
- Blair, S. M., s. Westheimer, G. 587, 599, 620
- Blakmore, C., s. Carpenter, R. H. S. 162, 186
- Blohmke, A., s. Sattler, C. H. 211, 232
- Bodin, M. A. 295, 296, 310, 312, 316
- Bodin, M., s. Benson, A. J. 111, 112, 115, 118, 123, 137, 182, 186, 234, 256, 263, 288, 292, 293, 294, 295, 309, 310, 311, 316, 546, 550, 573
- Bokhov, B. B., s. Arlaschenko, N. I. 353
- Bordogna, A., s. Girotti, G. 164, 187
- Boring, E. G. 160, 186, 566, 574
- Borison, H. L., Wang, S. C. 399, 403
- Bornhardt, A. 463, 465, 468, 484
- Bornschein, V. H., Schubert, G. 120, 137
- Bornstein, M. B., s. Babkin, B. P. 400, 402
- Borry, W., s. Jones, G. M. 429, 447
- Bos, J. H. 437, 444
- Bos, J. H., Jongkees, L. B. W., Philipszoon, A. J. 316
- Bos, J. H., Philipszoon, A. J. 410, 410, 437, 444
- Bourdon, B. 79, 86, 88, 137
- Bowsher, D., s. Walberg, F. 268, 274, 280
- Brady, J. F., s. Newsom, B. D. 354, 359
- Braemer, W. 156, 178, 180, 181, 186
- Braitenberg, V. 604, 615
- Braitenberg, V., Atwood, R. P. 604, 615
- Braitenberg, V., Onesto, N. 604, 616
- Brand, J. J. 365, 366
- Brand, J. L., s. Benson, A. J. 36, 137, 365, 366
- Brandt, Th., Dichgans, J. 118, 119, 138
- Brandt, Th., Dichgans, J., Koening, E. 118, 119, 138
- Brandt, Th., Wist, E., Dichgans, J. 119, 125, 138
- Brandt, Th., s. Dichgans, J. 116, 117, 118, 119, 125, 141, 401, 403
- Brandt, U. 426, 444
- Brandt, U., Fluor, E. 102, 138, 159, 416, 444
- Braun, G. I., s. Hellebrandt, F. A. 360
- Bray, P. F., Ziter, F. A., Lahey, M. E., Myers, G. G. 213, 229
- Brecher, G. A., Schubert, G. 160, 186
- Breuer, 7, 17, 68, 235
- Breuer, J. 276, 278, 414, 416, 425, 444
- Brindley, B. G. S. 604, 616
- Van den Brink, G., s. Miller, E. F. 86, 94, 149, 241, 264
- Brodal, A. 126, 138, 574, 589
- Brodal, A., Pompeiano, O., Walberg, F. 268, 278, 565, 574
- Brodal, A., s. Pompeiano, O. 268, 280
- Brodal, A., s. Walberg, F. 268, 274, 280
- Bromiley, R. B., s. Bard, P. 607, 615
- Brown, J. H. 41, 42, 43, 46, 59, 138, 373, 383, 574
- Brown, J. H., Crampton, G. H. 61, 62, 131, 138, 377, 380, 383
- Brown, J. H., Marshall, J. E. 370, 383
- Brown, J. H., Wolfe, J. W. 60, 138
- Brown, J. H., s. Marshall, J. E. 131, 148, 365, 367, 376, 377, 381, 387
- Brown, J. L. 91, 92, 138, 235, 249, 263
- Brown, K. R., s. York, E. 359
- Brown, L. 182, 186
- Brown, M. B., s. Ritvo, E. R. 365, 368
- Brown, R. H., Guedry, F. E. 379, 380, 383
- Brown, R. H., Imus, H., Niven, J. I., Graybiel, A. 23, 138
- Brown, R. H., s. Graybiel, A. 75, 82, 107, 143, 508, 542, 575
- Brucher, J. M. 611, 612, 616
- Bruck, A. 357
- Brun, E., Knudson, E., Raaschov, F. 393, 403
- Brunia, C. H. M., Hoppenbrouwers, T. 271, 278
- Brunner, H. 428, 444
- Bruns, O. 406, 410, 444
- Brunswik, E. 156, 177, 180, 186

- Brunswik, E., Kardos, L. 157, 186
- Bryanov, I. I., s. Yuganov, E. M. 554, 556, 580
- Buddenbrock, W. von 465, 484
- Bühler, K. 156, 157, 186
- Bürgi, S. 353
- Burke, U. L., s. Maxwell, S. S. 371, 372, 373, 387
- Burt, N. E. 85, 138
- Buser, P., Imbert, M. 600, 616
- Van Buskirk, W. C. 579
- Busygin, V. Ye., s. Arlaschenko, N. I. 353
- Buxton, C. E., s. Seashore, R. H. 356
- Buys, E. 62, 138, 415, 418, 420, 444
- Buys, E., Dohlman 426
- Byford, G. H. 22, 23, 35, 117, 138, 380, 383
- Byford, G., s. Hallpike, C. S. 25, 145, 429, 446
- Cairns, H., s. Hallpike, C. S. 576
- Cajal 217
- Caldwell, G. M., s. Alden, F. D. 357
- Callahan, F. E. 358
- Camarda, V., s. Caporale, R. 376, 383
- Camis, M. 283, 316, 470, 471, 484, 485
- Candland, D. K., s. Vernon, J. A. 359
- Canella, C. J., s. Mann, C. W. 35, 147
- Cannon, W. B. 574
- Cannon, W. B., Haimovici, H. 459, 460
- Cannon, W. B., Rosenblueth, A. 459, 460
- Cantrell, R. P. 357
- Caporale, R., Camarda, V. 376, 383
- Cappel, K. 58, 138, 508, 574
- Capps, M. J., Collins, W. E. 370, 371, 373, 383
- Carlstrom, D. 16, 138
- Carmichael, E. A., Dix, M. R., Hallpike, C. S. 222, 229
- Carpenter, M. B. 616
- Carpenter, M. B., Fabrega, H., Glinsmann, W. 479, 485
- Carpenter, M. S. 358
- Carpenter, R. H. S. 589, 616
- Carpenter, R. H. S., Blakmore, C. 162, 186
- Cawthorne, T., Dix, M., Hallpike, C., Hood, J. 43, 52, 138, 506, 574
- Cawthorne, T. E., Fitzgerald, G., Hallpike, C. S. 451, 454, 460, 472, 483, 485
- Cawthorne, T., Hallpike, C. S. 437, 444
- Cenacchi, V., Fenu, G., Gabrielli, L. 364, 366
- Ceran, S. J., s. Guedry, F. E. 43, 45, 46, 50, 58, 59, 144, 506, 575
- Chambers, W. W., Sprague, J. M. 478, 485
- Chambers, W. W., s. Liu, C. N. 459, 461
- Chambers, W. W., s. Sprague, J. M. 478, 489
- Chandler, K. A., s. Werner, H. 94, 154, 163, 190, 241, 266
- Chinn, H., Smith, P. 389, 403
- Chow, K. L. Riesen, A. H., Newell, F. W. 211, 229
- Christian, P. 25, 138
- Chusid, J. G., Gutiérrez-Mahoney, G. G. de 482, 485
- Chutorian, A. M., s. Solomon, G. E. 213, 232
- Cipriani, A. 391, 403
- Citron, C., Hallpike, C. S. 437, 444
- Clark, B. 23, 25, 72, 82, 86, 138, 139
- Clark, B., Graybiel, A. 56, 72, 86, 90, 94, 96, 107, 108, 110, 139, 164, 175, 186, 247, 249, 263, 325, 351, 353, 399, 401, 403, 542, 574
- Clark, B., Graybiel, A., MacCorkquodale, K. 25, 139
- Clark, B., Stewart, J. D. 23, 25, 26, 27, 28, 30, 35, 42, 55, 58, 59, 63, 117, 139, 380, 383
- Clark, B., s. Graybiel, A. 22, 82, 86, 93, 95, 131, 143, 162, 179, 187, 247, 263, 392, 403, 567, 575
- Clark, G., Lashley, K. S. 612, 616
- Clark, L. B. 465, 485
- Clark, Wilbur, C. 573
- Clarke, M., s. Precht, W. 452, 461
- Clarkson, F., s. McFarland, J. H. 175, 188
- Claude, H., Baruk, H., Aubry, M. 361, 365, 366
- Clegg, W. C., Dunfield, N. M. 72, 85, 139
- Clynes, M. 571, 574
- Coats, A. C., Smith, S. Y. 304, 305, 316
- Cobb, S., s. Schaltenbrand, G. 476, 489
- Coermann, R. R. 359
- Cohen, B. 229
- Cohen, B., Henn, V. 217, 229, 590, 616
- Cohen, B., Highstein, S. M. 115, 126, 139
- Cohen, B., Suzuki, J., Bender, M. B. 586, 616
- Cohen, B., Takemori, S. 116, 126, 140
- Cohen, B., Takemori, S., Uemura, T. 119, 125, 140
- Cohen, B., s. Aschoff, J. C. 587, 597, 598, 615
- Cohen, B., s. Goto, K. 362, 367
- Cohen, B., s. Uemura, T. 203, 205, 221, 232, 475, 489
- Cohen, L. A. 206, 229, 584, 616
- Cohen, M. M., Crosbie, R. J., Blackburn, L. H. 107, 140
- Colbert, E. G., Koegler, R. R., Markham, C. H. 365, 366
- Colehour, J. K. 401
- Colehour, J. K., Graybiel, A. 400, 403
- Colehour, J. K., s. Graybiel, A. 134, 143, 338, 342, 352, 567, 575
- Colenbrander, A. 100, 140, 159, 186, 241, 263
- Collard, M., s. Thiébaud, F. 356
- Collewijn, H. 588, 599, 616
- Collewijn, H., Van der Mark, F. 587, 616
- Collins, V. D., Howe, E. C. 353, 355
- Collins, W. E. 36, 44, 46, 66, 67, 115, 118, 124, 132, 134, 140, 316, 363, 364, 365, 366, 370, 371, 372, 373, 374, 375, 376, 378, 379, 380, 381, 382, 383, 384, 425, 444, 574
- Collins, W. E., Crampton, G. H., Posner, J. B. 362, 366
- Collins, W. E., Guedry, F. E. 53, 54, 59, 60, 62, 135, 140, 363, 366, 381, 384, 423, 444

- Collins, W. E., Guedry, F. E., Posner, J. B. 363, 366, 375, 384
- Collins, W. E., Mertens, R. A. 378, 380, 384
- Collins, W. E., Poe, R. H. 365, 366
- Collins, W. E., Posner, J. B. 362, 366
- Collins, W. E., Schroeder, D. J., Gilson, R. D., Guedry, F. E. 130, 140
- Collins, W. E., Schroeder, D. J., Hill, R. J. 130, 140
- Collins, W. E., Schroeder, D. J., Mertens, R. A. 376, 381, 384
- Collins, W. E., Schroeder, D. J., Rice, N., Mertens, R. A., Kranz, G. 547, 574
- Collins, W. E., Updegraff, B. P. 370, 373, 384
- Collins, W. E., s. Capps, M. J. 370, 371, 373, 383
- Collins, W. E., s. Gilson, R. D. 130, 142
- Collins, W. E., s. Guedry, F. E. 60, 61, 62, 65, 118, 131, 132, 135, 144, 145, 363, 365, 367, 374, 377, 378, 379, 381, 386
- Collins, W. E., s. Mertens, R. A. 370, 371, 372, 373, 387
- Collins, W. E., s. Schroeder, D. J. 130, 151
- Coltheart, M. 162, 186
- Conrad, B., s. Aschoff, J. C. 199, 208, 210, 229, 587, 606, 615
- Conraux, C., s. Greiner, G. F. 223, 230
- Conraux, C., s. Thiébaud, F. 356
- Corlett, B. M. A., s. Money, K. E. 285, 288, 308, 319
- Correia, M. J. 85, 140, 574
- Correia, M. J., Guedry, F. E. 75, 111, 113, 115, 140, 182, 186, 290, 292, 309, 310, 311, 316, 365, 367, 392, 403, 546, 574
- Correia, M. J., Hixson, W. C., Niven, J. I. 98, 99, 100, 101, 103, 140, 164, 165, 186
- Correia, M. J., Money, K. E. 112, 140, 312, 316, 551, 574
- Correia, M. J., s. Hixson, W. C. 10, 12, 13, 15, 120, 146
- Correia, M. J., s. McLeod, M. E. 304, 319
- Correia, M. J., s. Niven, J. I. 75, 77, 106, 111, 150, 308, 310, 311, 319, 391, 404, 506, 561, 578, 579
- Corso, J. I. 36, 140
- Corvera, J., Hallpike, C. S., Schuster, E. H. J. 17, 140
- Cotzin, M., s. Alexander, S. J. 262, 263
- Cowey, A., s. Latto, R. 612, 618
- Cramer, D. B., s. Fregly, A. R. 322, 351
- Cramer, D. B., s. Graybiel, A. 259, 261, 262, 264, 333, 352
- Cramer, R. L. 33, 140, 517, 574
- Cramer, R. L., s. Dowd, P. J. 377, 384
- Cramer, R. L., s. Guedry, F. E. 61, 63, 64, 145
- Cramer, R. L., s. Mathog, R. H. 577
- Crampton, G. H. 286, 287, 300, 316, 364, 367, 370, 371, 373, 384, 400, 403, 482, 485, 508, 550, 552, 565, 574, 575
- Crampton, G. H., Gall, K. 60, 140, 575
- Crampton, G. H., Schwam, W. J. 362, 367, 373, 384
- Crampton, G. H., Young, F. A. 119, 140
- Crampton, G. H., s. Brown, J. H. 61, 62, 131, 138, 377, 380, 383
- Crampton, G. H., s. Collins, W. E. 362, 366
- Crickmar, S. D., s. Ross, H. E. 91, 151
- Critchley, M. 8, 141
- Crosbie, R. J., s. Cohen, M. M. 107, 140
- Crosbie, R. J., s. Gray, R. F. 299, 317
- Crosby, E. C., Humphrey, T., Lauer, E. W. 7, 8, 141
- Crosby, E. C., s. Henderson, J. W. 612, 617
- Culbert, S. S. 169, 186
- Cullen, J. F., Harper, C. R. 104, 141
- Cunningham, D. R. 358
- Cunningham, D. R., Goetzinger, C. P. 358
- Cummings, M., s. Guedry, F. E. 60, 63, 64, 145
- Cureton, T. K. 358
- Curran, C. R., Lane, H. L. 181, 187
- Cyon, E. 463, 465, 485
- Dain, C. A. 358
- Dallenbach, K. M., s. Worchel, P. 354
- Dallos, P. J., Jones, R. W. 589, 616
- Dal Ri, H., Schaefer, K. P. 479, 481, 485
- Dandy, W. E. 353, 439, 444
- Dauterive, H. J., s. Mann, C. W. 84, 86, 88, 147
- Davey, P. R. 358
- Davies, J. D., s. Dearnaley, E. J. 378, 384
- Day, M. A. C. 359
- Day, R., Wade, N. 72, 141, 174, 187
- Day, R. H., s. Wade, N. J. 72, 153
- Deane, F. R., s. Graybiel, A. 342, 352
- Dearnaley, E. J., Reason, J. T., Davies, J. D. 378, 384
- Decher, H. 223, 229
- Deecke, L., Scheid, P., Kornhuber, H. H. 600, 616
- Deecke, L., s. Becker, W. 601
- Deecke, L., s. Kornhuber, H. H. 600, 601, 618
- De Haan, P. 357
- Deitlein, L. F., s. Graybiel, A. 103, 104, 143, 242, 244, 264
- De Lage, J. 408
- Delage, Y., s. Aubert, H. 408, 410, 418, 419, 433, 443
- Demanez, J. P., s. Ledoux, A. 222, 231
- Dèmetriades, T. D., s. Spiegel, E. A. 451, 456, 462, 475, 489
- Denny-Brown, D. 610, 611, 612, 616
- Deriu, P. L., s. Azzena, G. B. 475, 484
- Derwort, A. 162, 187
- Diaz, E., s. Benson, A. J. 75, 111, 113, 137
- Diaz, E., s. Reason, J. T. 120, 125, 132, 150
- Dichgans, J. 118
- Dichgans, J., Brandt, Th. 116, 117, 118, 119, 125, 141, 401, 403
- Dichgans, J., Held, R., Young, L., Brandt, Th. 119, 125, 141

- Dichgans, J., Jung, R. 117, 141
 Dichgans, J., Körner, F., Voigt, K. 117, 141
 Dichgans, J., Kornhuber, H. H. 208, 211, 229
 Dichgans, J., s. Brandt, Th. 118, 119, 125, 138
 Dichgans, J., s. Körner, F. 117, 146
 Dichgans, J., s. Schmidt, C. L. 607, 620
 Di Giorgio, A. M. 476, 485
 Di Giorgio, A. M., Manni, E. 475, 485
 Von Diringshofen, H. 119, 153
 Von Diringshofen, H., Kessel, G., Osypka, P. 25, 153
 Van Dishoeck, H. A. E., Spoor, A., Nijhoff, P. 8, 22, 35, 117, 153, 380, 384, 416, 444, 579
 Dittler, R. 417, 444
 Divorkin, S., s. Babkin, B. P. 400, 402
 Dix, M. R., Hallpike, C. S. 206, 230, 437, 444
 Dix, M. R., Hood, J. D. 375, 376, 377, 384
 Dix, M. R., s. Carmichael, E. A. 222, 229
 Dix, M., s. Cawthorne, T. 43, 52, 138, 506, 574
 Dobie, T. B. 42, 141
 Dockeray, F. C., Isaacs, S. 353
 Dockstader, S. L. 30, 141
 Dodge, R. 25, 58, 141, 361, 367, 374, 382, 384, 418, 434, 444
 Dodge, R., s. Travis, R. C. 44, 77, 78, 152
 Dohlman, G. 220, 230, 451, 460, 513, 514, 561, 573, 575
 Dohlman, s. Buys, E. 426
 Dolley, W. L. 465, 485
 Dolowitz, D. A. 420, 425, 445
 Dolowitz, D. A., Forssman, B., Henriksson, N. G. 269, 278
 Dolowitz, D. A., s. Forssman, B. 374, 378, 380, 385
 Dolowitz, D. A., s. Henriksson, N. G. 226, 230, 269, 279
 Domagk, G. F., Zippel, H. P. 482, 485
 Donaldson, J. M. L., s. Albe-Fessard, D. 609, 615
 Donoso, M., s. Hernández-Péon, R. 67, 145
 Doty, R. L. 28, 30, 141, 582
 Douglas, W. K. 358
 Douglas, W. K., s. Minners, H. A. 358
 Douglass, C. G., s. Green, R. E. 353
 Dow, R. S. 485
 Dowd, P. J. 364, 365, 367
 Dowd, P. J., Cramer, R. L. 377, 384
 Drake, C. G., Stavraký, G. W. 459, 460
 Draper, C. S., Wrigley, W., Hovorka, J. 496, 575
 Dreyfuss, R. 469, 485
 Duensing, F., Schaefer, K. P. 69, 141, 287, 317, 452, 453, 454, 460, 464, 469, 485, 586, 590, 616
 Duensing, F., Schaefer, K. P., Trevisan, C. 484, 486
 Duffy, F. H., Lombrose, C. T. 130, 141
 Dumont, S. 287, 317
 Duncker, K. 178, 179, 187
 Dunfield, N. M., s. Clegg, W. C. 72, 85, 139
 Dunlap, K. 371, 373, 384
 Dusek, E. R. 357, 358
 Dzendolet, E. 359, 555, 556, 575
 Eberhart, H. D., Inman, V. T. 359
 Eccles, J. C., Ito, M., Szentágothai, J. 604, 616
 Eckel, W. 285, 317, 452, 454, 460, 464, 486
 Ectors, L., s. Kennard, M. A. 611, 612, 617
 Edholm, O. G., s. Barcroft, H. 393, 402
 Edwards, A. S. 355
 Van Egmond, A. A. J., Groen, J. J., Hulk, J., Jongkees, L. B. W. 425, 430, 445
 Van Egmond, A. A. J., Groen, J. J., Jongkees, L. B. W. 19, 20, 25, 28, 29, 30, 33, 34, 44, 60, 121, 153, 285, 317, 415, 420, 423, 425, 428, 430, 432, 445, 455, 462, 472, 483, 486, 502, 506, 507, 579
 Van Egmond, A. A. J., Jongkees, L. B. W., Groen, J. J. 428, 445
 Egyed, J., s. Spiegel, E. A. 8, 152
 Eijsvogel, M. H., s. Quix, F. H. 182, 189
 Einstein 103, 104
 Ek, J., Jongkees, L. B. W., Klijn, J. 23, 30, 58, 141, 423, 425, 432, 445
 Ek, J., s. Klijn, J. A. J. 427, 447
 Ekvall, L., s. Grant, G. 205, 230
 Elftman, H. 359
 Elsner, W. 42, 141
 Emel'ianov, M. D., s. Galle, R. R. 126, 142
 Engen, T., Ross, B. M. 40, 141
 Engström, H., Lindeman, H. H., Ades, H. W. 70, 142
 Engström, H., Wersäll, J. 69, 141
 Erikson, J. H., s. Lachman, J. 365, 367
 Eriksson, A. W., s. Vliet, A. G. M. van 211, 232
 Eriksson, L., s. Fluor, E. 200, 230
 Escher, F. 472, 486
 Eviatar, A., s. Ritvo, E. R. 365, 368
 Ewald 430
 Ewald, J. R. 291, 317, 451, 452, 460, 463, 464, 465, 466, 467, 468, 471, 472, 482, 486
 Van Eyck, M. 451, 462
 Fabrega, H., s. Carpenter, M. B. 479, 485
 Farber, Yu. V., s. Arlaschenko, N. I. 353
 Farmer, T. W., Mustian, V. M. 353
 Farrugia, P., s. Benson, A. J. 75, 111, 113, 137
 Fearing, F. S. 355, 361, 367, 373, 384, 421, 445
 Fearing, F. S., Mowrer, O. H. 361, 367, 373, 384
 Fearing, F., s. Halstead, W. 373, 386
 Feilchenfeld, H. 93, 142
 Feldmann, H. 445
 Fender, D. H., s. St.-Cyr, G. J. 589, 620
 Fenu, G., s. Cenacchi, V. 364, 366
 Feoktistov, Yugatov 556
 Fernández, C. 205, 230
 Fernández, C., Fredrickson, J. M. 115, 126, 142

- Fernández, C., Goldberg, J. M. 19, 39, 142, 507, 509, 510, 512, 515, 527, 552, 575
- Fernández, C., Goldberg, J. M., Abend, W. K. 532, 575
- Fernández, C., Lindsay, J. R. 408, 410, 445
- Fernández, C., Schmidt, R. 370, 385
- Fernández, C., s. Fredrickson, J. M. 221, 230
- Fernández, C., s. Goldberg, J. M. 60, 62, 143, 452, 461, 509, 510, 512, 515, 524, 575
- Fernández, C., s. Henriksson, N. G. 370, 371, 373, 386
- Fernández, C., s. Proctor, L. R. 370, 373, 387
- Fernández, C. s. Reding, G. R. 261, 265
- Ferreri, G. 414, 445
- Figge, U., s. Fredrickson, J. 8, 142
- Finer, B. L., s. Aschan, G. 365, 366
- Finney, L. M., s. White, W. J. 359
- Fischer, J. J. 353
- Fischer, M. H. 93, 142, 159, 163, 164, 179, 187, 417, 418, 425, 435, 445, 464, 465, 471, 472, 480, 486
- Fischer, M. H., Veits, C. 418, 435, 445
- Fischer, M. H., Wodak, E. 269, 270, 271, 272, 274, 276, 278, 429, 433, 445
- Fischer, M. H., s. Wodak, E. 270, 280
- Fisher, M. B., Birren, J. E., Leggett, A. L. 355, 358
- Fiske, D. 353
- Fitts, P. M., s. Jones, R. E. 85, 146
- Fitzgerald, G., Hallpike, C. S. 222, 230
- Fitzgerald, G., s. Cawthorne, T. E. 451, 454, 460, 472, 483, 485
- Fleishman, E. A. 72, 85, 142, 358
- Floberg, I. E., Hamburger, C. A., Hydén, H. 482, 486
- Flock, A., Wersäll, J. 519, 575
- Flourens, J. P. M. 291, 307, 317, 405, 410, 445, 463, 465, 486
- Fluur, E. 17, 102, 142, 451, 452, 454, 460, 486
- Fluur, E., Eriksson, L. 200, 230
- Fluur, E., Mellström, A. 69, 102, 142, 163, 165, 187, 235, 263
- Fluur, E., Mendel, L. 374, 378, 385
- Fluur, E., s. Brandt, U. 102, 138, 159, 416, 444
- Foerster, O. 609, 616
- Ford, F. R., Walsh, F. B. 353
- Forsius, H., s. Vliet, A. G. M. 211, 232
- Forssman, B. 376, 378, 380, 385, 426, 445
- Forssman, B., Henriksson, N. G., Dolowitz, D. A. 374, 378, 380, 385
- Forssman, B., s. Dolowitz, D. A. 269, 278
- Forssman, B., s. Henriksson, N. G. 226, 230, 269, 279
- Fowler, E. P., Jr., s. Glorig, A. 353
- Franks, W. R., s. Johnson, W. H. 390, 391, 392, 403, 558, 576
- Franseen, E. B., s. Hellebrandt, F. A. 276, 279, 360
- Franzen, R., s. McFarland, R. A. 356
- Fredrickson, J. M., Fernández, C. 221, 230
- Fredrickson, J., Figge, U., Scheid, P., Kornhuber, H. H. 8, 142
- Fredrickson, Kornhuber, Schwarz 159
- Fredrickson, J. M., Schwarz, D., 72, 142, 287, 317
- Fredrickson, J. M., Schwarz, D. Kornhuber, H. H. 230, 287, 317, 584, 609, 616
- Fredrickson, J. M., s. Fernández, C. 115, 126, 142
- Freedman, S. J. 134, 142
- Fregly, A. R., Bergstedt, M., Graybiel, A. 347, 351
- Fregly, A. R., Graybiel, A. 250, 263, 321, 322, 323, 324, 328, 330, 333, 336, 345, 346, 350, 351
- Fregly, A. R., Graybiel, A., Smith, M. J. 322, 333, 338, 351
- Fregly, A. R., Kennedy, R. S. 344, 351
- Fregly, A. R., Oberman, A., Graybiel, A., Mitchell, R. E. 324, 351
- Fregly, A. R., Smith, M. J., Graybiel, A. 322, 338, 351
- Fregly, A. R., Smith, M. J., Wood, C. D., Cramer, D. B. 322, 351
- Fregly, A. R., s. Graybiel, A. 134, 143, 234, 235, 261, 262, 263, 264, 321, 322, 323, 324, 333, 338, 342, 350, 351, 352, 567, 575
- Fregly, A. R., s. Igarashi, M. 321, 352
- Fregly, A. R., s. McClure, J. A. 399, 404
- Fregly, A. R., s. Miller, E. F. 86, 93, 94, 95, 96, 149, 241, 264, 325, 352
- French, R. S., s. Newsom, B. D. 354
- Frenzel, H. 198, 200, 204, 221, 230, 438, 439, 445, 454, 460, 482, 483, 486
- Freud 570, 614
- Friedberg, J., s. Money, K. E. 399, 400, 404, 407, 411, 448
- Fries, E. C., s. Hellebrandt, F. A. 360
- Frisina, R. 358
- Fuchs, A. F. 589, 616
- Fuchs, A. F., Kornhuber, H. H. 586, 598, 599, 616
- Fuchs, A. F., Luschei, E. S. 586, 590, 617
- Fuchs, A. F., s. Becker, W. 591, 596, 615
- Fuchs, A. F., s. Robinson, D. A. 592, 612, 619
- Fujimoto, T., s. Tokita, T. 355
- Fujita, Y., Rosenberg, J., Segundo, J. P. 452, 460
- Fukuda, T. 270, 273, 278, 354, 584, 617
- Fukuda, T., Hinoki, M., Tokita, T. 373, 378, 385
- Fukuda, T., Tokita, T. 353, 354, 357
- Fukuda, T., Tokita, T., Aokia, S., Watanabe, T., Hishida, K., Tashiro, K., Miyata, H., Mazuoka, U. 376, 377, 385
- Furukawa, R., s. Honjo, S. 357

- Gabrielli, L., s. Cenacchi, V. 364, 366
- Gaefke, H. 592, 593, 617
- Galambos, R., s. Rupert, A. 452, 461
- Galebsky, A. 6, 142
- Gall, K., s. Crampton, G. H. 60, 140, 575
- Galle, R. R., Emel'ianov, M. D. 126, 142
- Galle, R. R., Yemel'yanov, M. D. 359
- Garcin, R., s. Rademaker, G. G. J. 277, 280, 584, 619
- Garner, W. R. 57, 142
- Garner, W. R., Hake, H. W. 56, 57, 142
- Garten, S. 88, 90, 142, 164, 187
- Gastaut, H. 215, 230
- Gazenko, O. 254, 263
- Gear, R. J., s. Grieve, D. W. 360
- Geissler, H. G. 175, 187
- Gelb, A. 162, 187
- Geldard, F. A. 7, 142
- Gernandt, B. E. 72, 142, 268, 279, 284, 285, 286, 287, 317, 426, 445, 452, 454, 460, 586, 617
- Gernandt, B., Igarashi, E. M., Ades, H. W. 434, 445
- Gernandt, B. E., Thulin, C. A. 268, 279, 452, 454, 460, 464, 486
- Gernandt, B., s. Andersson, S. 7, 136
- Gescheider, G. A., Wright, J. H. 85, 142
- Ghent, L., s. Semmes, J. 8, 151
- Gibson, J. J. 156, 162, 166, 168, 173, 178, 181, 187
- Gibson, J. J., Mowrer, O. H. 109, 119, 142, 160, 162, 187
- Gibson, J. J., Radner, M. 160, 162, 169, 187
- Gierke 527
- Gierke, H. E. von, s. Harris, C. S. 358
- Gierke, H. E. von, s. Nixon, C. W. 359
- Gilbreth, D. A. 575
- Gildenberg, P. L., Hassler, R. 475, 486
- Gillingham, K. K. 365, 367
- Gillingham, K., s. McCabe, B. F. 426, 448
- Gilson, R. D., Guedry, F. E., Stockwell, C. W. 131, 142
- Gilson, R. D., Schroeder, D. J., Collins, W. E., Guedry, F. E. 130, 142
- Gilson, R. D., Stockwell, C. W., Guedry, F. E. 56, 62, 142
- Gilson, R. D., s. Collins, W. E. 130, 140
- Gilson, R. D., s. Guedry, F. E. 45, 53, 56, 108, 145
- Gilson, R. D., s. Schroeder, D. J. 130, 151
- Gilson, R. D., s. Stockwell, C. W. 65, 152
- Giretti, M. L. 476, 478, 486
- Giretti, M. L., s. Azzena, G. B. 475, 484
- Giretti, M. L., s. Manni, E. 475, 488
- Girotti, G. 164, 187
- Girotti, G., Bordogna, A. 164, 187
- Glinsmann, W., s. Carpenter, M. B. 479, 485
- Glorig, A., Fowler, E. P., Jr. 353
- Goble, G. J., s. Newsom, B. D. 354, 359
- Goetzinger, C. P. 358
- Goetzinger, C. P., s. Cunningham, D. R. 358
- Goetzinger, C. P., s. Scanlon, S. L. 359
- Goldberg, J. M., Fernández, C. 60, 62, 143, 452, 461, 509, 510, 512, 515, 524, 575
- Goldberg, J. M., s. Fernández, C. 19, 39, 142, 507, 509, 510, 512, 515, 527, 532, 552, 575
- Goldberg, L. 276, 279, 355, 359
- Goldberg, L., s. Aschan, G. M. 307, 315
- Goldberg, M. E., s. Wurtz, R. H. 217, 232, 604, 620
- Goldfien, A., s. York, E. 359
- Goltz, F. 463, 464, 465, 466, 479, 486
- Gonshor, A. 134, 604, 617
- Gonshor, A., Melvill Jones, G. 131, 143
- Gonshor, A., s. Melvill Jones, G. 131, 148
- Goodson, J. E., s. Miller, J. W. 119, 120, 149
- Goorny, A. B., s. Benson, A. J. 36, 137, 365, 366
- Gorshikov, A. L., s. Yuganov, E. M. 554, 556, 580
- Goto, K. 357
- Goto, K., Tokumasu, K., Cohen, B. 362, 367
- Goto, T., s. Tokita, T. 355
- Grahe 79
- Grahe, K. 434, 445
- Grant, G., Aschan, G., Ekvall, L. 205, 230
- Grant, W. T. 355
- Gray, R. F., Crosbie, R. J. 299, 317
- Graybiel, A. 75, 143, 165, 234, 244, 256, 263, 324, 325, 330, 350, 351, 390, 392, 401, 403, 426, 429, 445, 573
- Graybiel, A., Brown, R. H. 75, 82, 107, 143, 508, 542, 575
- Graybiel, A., Clark, B. 82, 86, 93, 95, 143, 162, 179, 187, 247, 263, 325, 351
- Graybiel, A., Clark, B., MacCorquodale, K., Hupp, D. 22, 143
- Graybiel, A., Clark, B., Zariello, J. J. 131, 143, 353, 392, 403, 567, 575
- Graybiel, A., Fregly, A. R. 234, 263, 321, 322, 323, 350, 351
- Graybiel, A., Guedry, F. E., Johnson, W. H., Kennedy, R. 378, 380, 381, 385
- Graybiel, A., Hupp, D. I. 22, 23, 143, 380, 385
- Graybiel, A., Johnson, W. H. 143, 262, 263, 309, 317, 325, 351, 550
- Graybiel, A., Kellogg, R. S. 103, 143, 254, 263, 555, 575
- Graybiel, A., Kennedy, R. S., Knoblock, E. C., Guedry, F. E., Mertz, W., McLeod, M. E., Colehour, J. K., Miller, F. F., Fregly, A. R. 134, 143, 338, 352, 567, 575
- Graybiel, A., Kerr, W., Hupp, D., Bartley, S. 25, 58, 143
- Graybiel, A., Meek, J. C., Beischer, D. E., Riopelle, A. J. 575
- Graybiel, A., Miller, E. F. 75, 143, 234, 257, 262, 263, 264
- Graybiel, A., Miller, E. F., Billingham, J., Waite, R., Berry, C. A., Deitlein, L. F. 103, 104, 143, 242, 244, 264

- Graybiel, A., Miller, E. F., Newsom, B., Kennedy, R. 91, 96, 143, 164, 187, 237, 247, 256, 264
- Graybiel, A., Niven, J. I., MacCorquodale, K. 299, 317, 416, 434, 445
- Graybiel, A., Patterson, J. L. 81, 85, 143, 247, 252, 264
- Graybiel, A., Schuknecht, H. F., Fregly, A. R., Miller, E. F. II., McLeod, M. E. 235, 264, 324, 333, 352
- Graybiel, A., Smith, C. R., Guedry, F. E., Jr., Miller, E. F. II., Fregly, A. R., Cramer, D. B. 261, 262, 264, 333, 352
- Graybiel, A., Stockwell, C. W., Guedry, F. E., Jr. 234, 262, 264
- Graybiel, A., Thompson, A. B., Deane, F. R., Fregly, A. R., Colehour, J. K., Ricks, E. L. 342, 352
- Graybiel, A., Whiteside, W. H. 575
- Graybiel, A., Wood, C. D. 402, 403
- Graybiel, A., Wood, C. D., Miller, E. F. II., Cramer, D. B. 257, 264
- Graybiel, A., s. Brown, R. H. 23, 138
- Graybiel, A., s. Clark, B. 25, 56, 72, 86, 90, 94, 96, 107, 108, 110, 139, 164, 175, 186, 247, 249, 263, 325, 351, 353, 399, 401, 403, 542, 574
- Graybiel, A., s. Colehour, J. K. 400, 403
- Graybiel, A., s. Fregly, A. R. 250, 263, 321, 322, 323, 324, 328, 330, 333, 336, 338, 345, 346, 347, 350, 351
- Graybiel, A., s. Guedry, F. E. 131, 132, 144, 145, 344, 352, 373, 377, 378, 381, 382, 386, 567, 576
- Graybiel, A., s. Harris, C. S. 365, 367
- Graybiel, A., s. Johnson, W. H. 399, 403, 500, 576
- Graybiel, A., s. Kellogg, R. S. 304, 318
- Graybiel, A., s. Kennedy, R. S. 345, 352, 354
- Graybiel, A., s. Lansberg, M. P. 256, 264, 300, 302, 318, 550, 577
- Graybiel, A., s. McClure, J. A. 399, 404
- Graybiel, A., s. McMitchael, A. E. 578
- Graybiel, A., s. Meek, J. C. 427, 448
- Graybiel, A., s. Miller, E. F. 86, 93, 94, 95, 96, 100, 103, 149, 159, 164, 165, 175, 179, 189, 234, 235, 239, 240, 241, 242, 251, 252, 257, 259, 262, 264, 265, 325, 330, 352, 525, 526, 578
- Graybiel, A., s. Minners, H. A. 358
- Graybiel, A., s. Niven, J. I. 262, 265, 354, 472, 483, 488
- Graybiel, A., s. Reason, J. T. 110, 120, 123, 131, 133, 151
- Graybiel, A., s. Roman, A. J. 298, 320
- Graybiel, A., s. Whiteside, T. D. M. 35, 154, 256, 266
- Graybiel, A., s. Woellner, R. C. 159, 190, 239, 266, 525, 580
- Green, R. E., Douglass, C. C. 353
- Greenberg, G. 178, 187
- Greene, D., s. Smith, K. U. 360
- Greiner, G. F., Conraux, C., Picart, P. 223, 230
- Griesbach, E., s. Holst, E. von 163, 188
- Grieve, D. W., Gear, R. J. 360
- Griffith, C. R. 361, 367, 371, 375, 376, 378, 381, 385, 581, 617
- Grigoryev, Yu. G., s. Arlaschenko, N. I. 353
- Grimes, R. H., s. White, W. J. 359
- Grippio, J., s. Precht, W. 458, 461
- Groebbels, F. 465, 486
- Groen, J. J. 6, 60, 62, 65, 67, 120, 143, 144, 294, 296, 317, 408, 410, 416, 419, 424, 425, 426, 429, 430, 445, 446
- Groen, J. J., Jongkees, L. B. W. 25, 28, 29, 31, 34, 44, 45, 46, 144, 362, 367, 378, 385, 421, 446, 506, 575
- Groen, J. J., Lowenstein, O., Vendrick, A. J. H. 19, 59, 62, 144, 283, 317, 415, 423, 446, 502, 508, 509, 510, 511, 512, 518, 575
- Groen, J. J., s. Van Egmond, A. A. J. 19, 20, 25, 28, 29, 30, 33, 34, 44, 60, 121, 153, 285, 317, 415, 420, 423, 425, 428, 430, 432, 445, 455, 462, 472, 483, 486, 502, 506, 507, 579
- Groen, J. J., s. Jongkees, L. B. W. 71, 73, 77, 78, 79, 80, 87, 146, 417, 418, 419, 436, 447, 516, 576
- Grözinger, B., s. Becker, W. 601
- Gualtierotti, T., Alltucker, D. S. 452, 461, 464, 486
- Guedry, F. E. 9, 23, 48, 56, 60, 61, 66, 74, 75, 77, 87, 92, 106, 111, 112, 113, 114, 115, 116, 119, 120, 123, 124, 125, 126, 127, 130, 131, 132, 133, 134, 144, 182, 187, 234, 264, 290, 294, 295, 309, 310, 317, 325, 352, 365, 367, 373, 375, 376, 377, 378, 379, 380, 381, 382, 385, 386, 392, 403, 446, 541, 546, 576
- Guedry, F. E., Ambler, R. K. 116, 126, 129, 130, 131, 144
- Guedry, F. E., Benson, A. J. 128, 144
- Guedry, F. E., Ceran, S. J. 43, 45, 46, 50, 58, 59, 144, 506, 575
- Guedry, F. E., Collins, W. E. 60, 61, 62, 65, 135, 144, 381, 386
- Guedry, F. E., Collins, W. E., Graybiel, A. 131, 132, 145, 377, 378, 381, 386
- Guedry, F. E., Collins, W. E., Sheffey, P. L. 118, 145, 363, 365, 367, 374, 378, 379, 381, 386
- Guedry, F. E., Cramer, R. L., Koella, W. P. 61, 63, 64, 145
- Guedry, F. E., Graybiel, A. 131, 132, 144, 373, 377, 378, 382, 386, 567, 576
- Guedry, F. E., Graybiel, A., Collins, W. E. 377, 378, 381, 386

- Guedry, F. E., Harris, C. S. 74, 77, 87, 105, 106, 107, 145, 308, 317, 541, 576
- Guedry, F. E., Holmes, J. T. 130, 145
- Guedry, F. E., Jr., Kennedy, R. S., Harris, C. S., Graybiel, A. 344, 352
- Guedry, F. E., Lauver, L. S. 44, 58, 59, 60, 145, 363, 367, 381, 386
- Guedry, F. E., Montague, E. K. 120, 123, 124, 145, 378, 380, 386, 527, 554, 576
- Guedry, F. E., Owens, G. G., Cummings, M., Norman, J. W. 60, 63, 64, 145
- Guedry, F. E., Owens, G. G., Norman, J. W. 44, 49, 58, 145
- Guedry, F. E., Richmond, G. 27, 28, 145
- Guedry, F. E., Stockwell, C. W., Gilson, R. D. 45, 53, 56, 108, 145
- Guedry, F. E., Stockwell, C. W., Norman, J. W., Owens, G. G. 44, 47, 48, 51, 52, 56, 108, 145
- Guedry, F. E., s. Ambler, R. K. 126, 136
- Guedry, F. E., s. Benson, A. J. 45, 53, 54, 111, 112, 113, 116, 128, 137, 290, 292, 309, 310, 311, 316, 548, 549, 552, 553, 566, 567, 574
- Guedry, F. E., s. Brown, R. H. 379, 380, 383
- Guedry, F. E., s. Collins, W. E. 53, 54, 59, 60, 62, 130, 135, 140, 363, 366, 375, 381, 384, 423, 444
- Guedry, F. E., s. Correia, M. J. 75, 111, 113, 115, 140, 182, 186, 365, 367, 392, 403, 546, 574
- Guedry, F. E., s. Gilson, R. D. 56, 62, 130, 131, 142
- Guedry, F. E., s. Graybiel, A. 134, 143, 234, 261, 262, 264, 333, 338, 352, 378, 380, 381, 385, 567, 575
- Guedry, F. E., s. Harris, C. S. 365, 367
- Guedry, F. E., Jr., s. Lansberg, M. P. 256, 264, 300, 302, 318, 550, 577
- Guedry, F. E., s. Mann, C. W. 22, 117, 148
- Guedry, F. E., s. Passey, G. E. 72, 85, 150
- Guedry, F. E., s. Schroeder, D. J. 130, 151
- Guedry, F. E., s. Stockwell, C. W. 65, 108, 109, 110, 152, 256, 265, 311, 320
- Günther, W. 195, 230
- Güttich, A. 270, 274, 279, 437, 446, 486
- Guignard, J. C. 360
- Guillemen, V., s. Torok, N. 220, 232
- Gulick, W. I., s. Vernon, J. A. 359
- Gurfinkel, V. S., s. Babskii, E. B. 359
- Gurnee, H. 77, 78, 145
- Gutierry-Mahoney, G. G. de, s. Chusid, J. G. 482, 485
- Gutman, J., s. Bergmann, F. 364, 366
- Guttich, A. 361, 367
- Haber, R. N. 134, 145
- Hagbarth, K. E., s. Aschan, G. 365, 366
- Haimovici, H., s. Cannon, W. B. 459, 460
- Hakas, P., Kornhuber, H. H. 222, 230
- Hake, H. W., s. Garner, W. R. 56, 57, 142
- Hallgren, B. 353
- Hallpike, C. S. 291, 317
- Hallpike, C. S., Cairns, H. 576
- Hallpike, C. S., Hood, J. D. 35, 43, 52, 63, 64, 145, 425, 429, 446
- Hallpike, C. S., Hood, J., Byford, G. 25, 145, 429, 446
- Hallpike, C. S., s. Carmichael, E. A. 222, 229
- Hallpike, C., s. Cawthorne, T. 43, 52, 138, 437, 444, 451, 454, 460, 472, 483, 485, 506, 574
- Hallpike, C. S., s. Citron, C. 437, 444
- Hallpike, C. S., s. Corvera, J. 17, 140
- Hallpike, C. S., s. Dix, M. R. 206, 230, 437, 444
- Hallpike, C. S., s. Fitzgerald, G. 222, 230
- Halpern, L. 162, 187
- Halstead, W. 373, 382, 386
- Halstead, W., Yacorzynski, G., Fearing, F. 373, 386
- Hamburger, C. A., Hydén, H. 482, 486
- Hamburger, C. A., s. Floberg, I. E. 482, 486
- Hamersma, H. 222, 230, 425, 434, 446
- Hammer, L. R. 103, 145
- Hampson, J., Harrison, C., Woolsey, C. 598, 617
- Hancock, J. A. 353
- Harden Jones, F. R. 559, 560, 576
- Harlan, W. L., s. Mahoney, J. L. 362, 367, 374, 386
- Harper, C. R., s. Cullen, J. F. 104, 141
- Harris, C. S., von Gierke, H. E. 358
- Harris, C. S., Guedry, F. E., Graybiel, A. 365, 367
- Harris, C. S., Sommer, H. S. 358
- Harris, C. S., s. Guedry, F. E. 74, 77, 87, 105, 106, 107, 145, 308, 317, 344, 352, 541, 576
- Harris, C. S., s. Nixon, C. W. 359
- Harris, J., s. Morant, R. B. 162, 189
- Harrison, C., s. Hampson, J. 598, 617
- Hasegawa, T. 165, 188
- Hassler, R. 217, 230
- Hassler, R., s. Gildenberg, P. L. 475, 486
- Hauty, G. T., s. Pearson, R. G. 72, 85, 150
- Havill, C. D., s. Sadoff, M. 25, 37, 151
- Hawkins, W. R., s. Minners, H. A. 358
- Haygood, Robert C., s. Lindholm, Ernest 573
- Head, H. 353, 358
- Heath, S. R. 358
- Hebb, D. O. 36, 145
- Hécaen, H., Ajuriaguerra, J. de 218, 230
- Hein, A., s. Held, R. 134, 145
- Held, R. 134, 135, 145
- Held, R., Hein, A. 134, 145

- Held, R., s. Dichgans, J. 119, 125, 141
- Hellebrandt, F. A., Braun, G. I. 360
- Hellebrandt, F. A., Franseen, E. B. 276, 279, 360
- Hellebrandt, F. A., Riddle, K. S., Larsen, E. M., Fries, E. C. 360
- Helmholtz 157
- Hemingway, A. 389, 399, 403
- Henderson, J. W. 371, 386
- Henderson, J. W., Crosby, E. C. 612, 617
- Henkes, H. E., s. Hulk, J. 446
- Henmon, V. A. C. 353
- Henn, V., s. Cohen, B. 217, 229, 590, 616
- Hennebert, P. E. 272, 276, 279, 420, 446
- Henriksson, N. G. 220, 226, 230
- Henriksson, N. G., Dolowitz, D. A., Forssman, B. 226, 230, 269, 279
- Henriksson, N. G., Forssman, B., Dolowitz, D. A. 269, 279
- Henriksson, N. G., Johansson, G., Olsson, L. G., Östlund, H. 276, 279, 360
- Henriksson, N. G., Kohut, R., Fernández, C. 370, 371, 373, 386
- Henriksson, N. G., Lundgren, A., Tibbling, L., Nilsson, A., Anderson, A. 36, 145
- Henriksson, N. G., s. Dolowitz, D. A. 269, 278
- Henriksson, N. G., s. Forssman, B. 374, 378, 380, 385
- Henriksson, N. G., s. Nilsson, A. 36, 150
- Hering 157
- Hernández-Péon, R., Donoso, M. 67, 145
- Hershey, Daniel, Ed. 562, 576
- Hertzberg, O. E. 358
- Hertzman, M., s. Witkin, H. A. 181, 190
- Heschl 438
- Hess, W. R. 612, 617
- Hicks, S. A. 358
- Highstein, S. M., s. Cohen, B. 115, 126, 139
- Hilding, A. C. 25, 146
- Hill, C. J., Jr., s. Alexander, S. J. 262, 263
- Hill, R. J., s. Collins, W. E. 130, 140
- Hill, R. M., s. Horn, G. 130, 146
- Hiltz, F. F. 566, 576
- Hinchcliffe, R. 380, 386, 434, 446
- Hinoki, M. 354
- Hinoki, M., Kitahara, M. 360
- Hinoki, M., Kurosawa, R. 437, 446
- Hinoki, M., s. Fukuda, T. 373, 378, 385
- Hinsdale, C. 356
- Hirsch, C. 272, 273, 279, 354
- Hishida, K., s. Fukuda, T. 376, 377, 385
- Hitzig 369
- Hixson, W. C. 39, 146
- Hixson, W. C., Niven, J. I. 66, 128, 146, 502, 507, 576
- Hixson, W. C., Niven, J. I., Correia, M. J. 10, 12, 13, 15, 120, 146
- Hixson, W. C., s. Correia, M. J. 98, 99, 100, 101, 103, 140, 164, 165, 186
- Hixson, W. C., s. Niven, J. I. 66, 75, 77, 106, 111, 150, 308, 310, 311, 319, 391, 404, 506, 561, 578, 579
- Hoehne, O., s. Becker, W. 600, 615
- Hofman, F. B. 182, 188
- Hofmann, F. B., Bielschowsky, A. 160, 188
- Holmes, J. T., s. Guedry, F. E. 130, 145
- Holsopple, J. Q. 376, 386
- Von Holst, E. 68, 98, 153, 178, 180, 181, 185, 188, 464, 466, 473, 486, 581, 582, 612, 617
- Holst, E. von, Griesbach, E. 163, 188
- Holst, E. von, Mittelstaedt, H. 156, 158, 169, 188, 416, 426, 446, 584, 617
- Homick, G. L., s. Berry, C. A. 402, 402
- Honjo, S., Furukawa, R. 357
- Hood, J. D. 419, 446
- Hood, J. D., Pfaltz, C. R. 362, 367, 373, 386
- Hood, J., s. Cawthorne, T. 43, 52, 138, 506, 574
- Hood, J. D., s. Dix, M. R. 375, 376, 377, 384
- Hood, J. D., s. Hallpike, C. S. 25, 35, 43, 52, 63, 64, 145, 429, 446
- Hoppenbrouwers, T., s. Brunia, C. H. M. 271, 278
- Horcholle-Bossavit, Tyé-Dumont 586
- Horn, G., Hill, R. M. 130, 146
- Horton, M. O., s. Alden, F. D. 357
- House, W. F. 333, 352
- Hovorka, J., s. Draper, C. S. 496, 575
- Howard, I. P., Templeton, W. B. 7, 17, 72, 82, 86, 94, 95, 117, 119, 120, 146, 160, 165, 178, 188
- Howe, E. C., s. Collins, V. D. 353, 355
- Howland, Howard, C. 573
- Hubbard, A. W., Stetson, R. H. 360
- Hubel, D. H., Wiesel, T. N. 172, 188
- Huddleston, O. L. 371, 373, 386
- Hudspath, W. J. 482, 487
- Huizinga, E. 165, 188, 465, 487
- Huizinga, E., s. Benjamins, C. E. 165, 186
- Hukuhara, J., s. Von Baumgarten, R. J. 580
- Hulk, J., Henkes, H. E. 446
- Hulk, J., Jongkees, L. B. W. 29, 146, 406, 410, 420, 430, 432, 446
- Hulk, J., s. Van Egmond, A. A. J. 425, 430, 445
- Hulk, J., s. Jongkees, L. B. W. 430, 431, 447
- Humphrey, T., s. Crosby, E. C. 7, 8, 141
- Hunter, J., s. Taylor, N. B. J. 401, 404
- Hupp, D., s. Graybiel, A. 22, 23, 25, 58, 143, 380, 385
- Husband, R. W. 356
- Hyden, Holger, Ed. 566, 567, 576
- Hydén, H., s. Floberg, I. E. 482, 486
- Hydén, H., s. Hamburger, C. A. 482, 486
- Ibid 577
- Igarashi, E. M., s. Gernandt, B. 434, 445

- Igarashi, M. 17, 146, 283, 317, 507, 510, 516, 576
- Igarashi, M., Fregly, A. R., Tokita, T. 321, 352
- Imamura, H., s. Takebayshi, H. 354
- Imbert, M., s. Buser, P. 600, 616
- Imus, H., s. Brown, R. H. 23, 138
- Inman, V. T., s. Eberhart, H. D. 359
- Ireland, P. E., s. Nito, Y. 319
- Irwin, J. A. 405, 410, 427, 446
- Isaacs, S., s. Dockeray, F. C. 353
- Isch, F., s. Thiébaud, F. 356
- Ismail, A. H., s. Bárány, J. W. 359
- Ito, M. 604, 617
- Ito, M., Nisimaru, N., Yamamoto, M. 586, 617
- Ito, M., Yoshida, M. 587, 617
- Ito, M., Yoshida, M., Obata, K. 587, 605, 617
- Ito, M., s. Eccles, J. C. 604, 616
- Iwase, K., s. Becker, W. 600, 615
- Jackson, M. M., Sears, C. W. 298, 317
- James, s. Nagel 7
- James, W. 90, 146, 405, 410, 446
- Janeke, J. B. 294, 308, 310, 315, 317
- Janeke, J. B., Oosterveld, W. J. 302, 317
- Janeke, M. 551, 576
- Jansen, J., s. Nyby, O. 602, 619
- Jatho, K. 223, 230, 439, 446
- Johansson, G., s. Henriksson, N. G. 276, 279, 360
- Johner, C. H., Perlman, H. B. 353, 365, 367
- Johnson, D. D., Torok, N. 375, 386
- Johnson, W. H. 392, 400, 403, 568
- Johnson, W., Jongkees, L. B. W. 427
- Johnson, W. H., Mayne, J. W. 403, 607, 617
- Johnson, W. H., Meek, J. C., Graybiel, A. 399, 403, 500, 576
- Johnson, W. H., Stubbs, R. A., Kelk, G. F., Franks, W. R. 390, 391, 392, 403, 558, 576
- Johnson, W. H., Taylor, N. B. J. 390, 403
- Johnson, W. H., s. Ackerman, U. 399, 402
- Johnson, W. H., s. Graybiel, A. 143, 262, 263, 309, 317, 325, 351, 378, 380, 381, 385, 550
- Johnson, W. H., s. Money, K. E. 285, 288, 308, 319
- Johnson, W. H., s. Nito, Y. 319
- Johnson, W. H., s. Sunahara, F. A. 393, 404, 408, 411, 449
- Johnson, W. H., s. Taylor, N. B. J. 401, 404
- Johnson, W. H., s. Taylor, W. J. R. 393, 397, 404
- Johnston, J. B. 582, 617
- Jones, E. G. 611
- Jones, E. G., Powell, T. P. S. 600, 610, 617
- Jones, G. M. 415, 447
- Jones, G. M., Borry, W., Kowalsky, W. 429, 447
- Jones, G. M., Spells, K. E. 585, 617
- Jones, G. M., s. Michael, J. 589, 619
- Jones, I. H. 353
- Jones, R. E., Milton, J. L., Fitts, P. M. 85, 146
- Jones, R. W., s. Dallos, P. J. 589, 616
- De Jong, J. M. B. V. 206, 230, 436, 437, 447
- De Jong, R. N. 353
- Jongkees, L. B. W. 17, 146, 163, 164, 165, 188, 226, 230, 291, 299, 304, 305, 306, 318, 353, 413, 414, 434, 436, 447
- Jongkees, L. B. W., Groen, J. J. 71, 73, 77, 78, 79, 80, 87, 146, 417, 418, 419, 436, 447
- Jongkees, L. B. W., Hulk, J. 430, 431, 447
- Jongkees, L. B. W., Klijn, J. A. J. 447
- Jongkees, L. B. W., Philipszoon, A. J. 234, 258, 264, 308, 318, 364, 367, 447
- Jongkees, L. B. W., s. Bos, J. H. 316
- Jongkees, L. B. W., s. Van Egmond, A. A. J. 19, 20, 25, 28, 29, 30, 33, 34, 44, 60, 121, 153, 285, 317, 415, 420, 423, 425, 428, 430, 432, 445, 455, 462, 472, 483, 486, 502, 506, 507, 579
- Jongkees, L. B. W., s. Ek, J. 23, 30, 58, 141, 423, 425, 432, 445
- Jongkees, L. B. W., s. Groen, J. J. 25, 28, 29, 31, 34, 44, 45, 46, 144, 362, 367, 378, 385, 421, 446, 506, 516, 575, 576
- Jongkees, L. B. W., s. Hulk, J. 29, 146, 406, 410, 420, 430, 432, 446
- Jongkees, L. B. W., s. Johnson, W. 427
- Jonsson, R., Steen, B. 360
- Jordan, P. 273, 274, 279, 354
- Joseph, J. 360
- Jürgens, R., s. Becker, W. 595, 615
- Jung, R. 220, 230, 482, 487
- Jung, R., Kornhuber, H. H. 212, 216, 231, 482, 483, 484, 487, 587, 589, 617
- Jung, R., s. Bender, M. B. 162, 186
- Jung, R., s. Dichgans, J. 117, 141
- Kado, R. T., s. Adey, W. R. 261, 263
- Kahn, A., s. Torok, N. 271, 280
- Kamath, R., s. Pfaltz, C. R. 451, 461
- Kamei, T., Kornhuber, H. H. 200, 201, 204, 231
- Karbowski, K. 408, 410, 447
- Kardos, L. 157, 188
- Kardos, L., s. Brunswik, E. 157, 186
- Kasyian, I. I., s. Yuganov, E. M. 554, 556, 580
- Kate, J. H. 508, 576
- Kato, N., s. Saito, I. 310, 320
- Keidel, Plattig 596, 603, 606
- Kelk, G. F., s. Johnson, W. H. 390, 391, 392, 403, 558, 576
- Keller, E. L., Robinson, D. A. 586, 617
- Kellogg, R. S. 103, 146, 159, 188, 525, 526, 528, 530, 531, 554, 576

- Kellogg, R. S., Graybiel, A. 304, 318
 Kellogg, R. S., s. Graybiel, A. 103, 143, 254, 263, 555, 575
 Kellogg, R. S., s. Miller, E. F. 103, 149, 239, 240, 252, 257, 262, 265
 Kelly, C. F., s. Winget, C. M. 373, 388
 Kemp, J. M., Powell, T. P. S. 602, 617
 Kempinsky, W. H. 8, 146
 Kennard, M. A. 612, 617
 Kennard, M. A., Ectors, L. 611, 612, 617
 Kennedy, R. S. 67, 110, 146
 Kennedy, R. S., Graybiel, A. 354
 Kennedy, R. S., Graybiel, A., McDonough, R. C., Beckwith, F. D. 345, 352
 Kennedy, R. S., s. Fregly, A. R. 344, 351
 Kennedy, R., s. Graybiel, A. 91, 96, 134, 143, 164, 187, 237, 247, 256, 264, 338, 352, 378, 380, 381, 385, 567, 575
 Kennedy, R. S., s. Guedry, F. E. 344, 352
 Kerr, W., s. Graybiel, A. 25, 58, 143
 Keser, H. 223, 225, 231
 Kessel, G., s. Von Diringshofen, H. 25, 153
 Khilov, K. L. 292, 318
 Kimble, G. A., Perlmutter, L. C. 5, 135, 146
 Kimura, K., s. Owada, K. 320
 King 291
 King, B. G. 371, 386
 Kinsbourne, M. 130, 146
 Kiørboe, F. 291, 313
 Kirstein, R. 220, 231
 Kishi, M., s. Takebayashi, H. 354
 Kislyakov, V. A., Orlov, I. V. 318
 Kitahara, M. 277, 279, 360
 Kitahara, M., Sato, T. 357
 Kitahara, M., Uno, R. 110, 146, 414, 447
 Kitahara, M., s. Hinoki, M. 360
 Klein, H. M., s. Becker, W. 199, 229
 Kleinknecht, F. 85, 146
 Kleint, H. 160, 163, 178, 179, 180, 188
 Kleyn, A. de 437, 468, 487, 586, 618
 Kleyn, A. de, Magnus, R. 284, 318
 Kleyn, A. de, Versteegh, C. 211, 231, 277, 279, 307, 318, 407, 410, 447
 De Kleyn, A., s. Magnus, R. 464, 465, 471, 472, 488
 Klijn, J. A. J., Ek, J. 427, 447
 Klijn, J. A. J., s. Ek, J. 23, 30, 58, 141, 423, 425, 432, 445
 Klijn, J. A. J., s. Jongkees, L. B. W. 447
 Klinke, R., Schmidt, C. L. 119, 146
 Klix, F. 163, 180, 188
 Klopp, H. W. 167, 188
 Knapp, E. 202, 231
 Knapp, H. 561, 576
 Knoblock, E. C., s. Graybiel, A. 134, 143, 338, 352, 567, 575
 Knoblock, E. C., s. Minners, H. A. 358
 Knudson, E., s. Brun, E. 393, 403
 Koch, G., s. Seashore, H. G. 354
 Koegler, R. R., s. Colbert, E. G. 365, 366
 Köhler, W., Wallach, H. 162, 188
 Koella, W. 292, 295, 296, 309, 310, 318
 Koella, W. P., s. Guedry, F. E. 61, 63, 64, 145
 Koenig, E., s. Brandt, Th. 118, 119, 138
 Körner, F., Dichgans, J. 117, 146
 Körner, F., s. Dichgans, J. 117, 141
 Körner, F., s. Schiller, P. H. 604, 619
 Koffka, K. 168, 188
 Kohler, I. 160, 166, 167, 188
 Kohut, R., s. Henriksson, N. G. 370, 371, 373, 386
 Kolb, G. 466, 467, 469, 473, 475, 476, 480, 482, 487
 Kolosov, I. A., s. Yuganov, E. M. 554, 556, 580
 Von Kongehl, G., Kornhuber, H. H. 56, 57, 153
 Kongehl, G., s. Bechinger, D. 56, 58, 136, 594, 615
 Kopanov, V. I., s. Yuganov, E. M. 554, 556, 580
 Kornhuber, H. H. 126, 146, 197, 198, 203, 205, 206, 207, 209, 210, 211, 212, 213, 214, 216, 218, 219, 220, 225, 226, 231, 439, 447, 464, 471, 482, 487, 566, 573, 576, 583, 584, 585, 587, 588, 589, 590, 596, 598, 599, 602, 603, 604, 605, 606, 607, 608, 611, 613, 614, 618
 Kornhuber, H. H., Aschoff, J. C. 600, 602, 610, 618
 Kornhuber, H. H., Deecke, L. 600, 601, 618
 Kornhuber, H. H., Krejcova, Schmidt 591
 Kornhuber, H. H., Waldecker, G. 195, 231
 Kornhuber, H. H., s. Aschoff, J. C. 199, 208, 210, 229, 587, 606, 615
 Kornhuber, H. H., s. Bader, W. 222, 229, 587, 615
 Kornhuber, H. H., s. Bechinger, D. 56, 58, 136, 594, 615
 Kornhuber, H. H., s. Becker, W. 600, 601, 615
 Kornhuber, H. H., s. Deecke, L. 600, 616
 Kornhuber, H. H., s. Dichgans, J. 208, 211, 229
 Kornhuber, H. H., s. Fredrickson, J. 8, 142, 159, 230, 287, 317, 584, 609, 616
 Kornhuber, H. H., s. Fuchs, A. F. 586, 598, 599, 616
 Kornhuber, H. H., s. Hakas, P. 222, 230
 Kornhuber, H. H., s. Jung, R. 212, 216, 231, 482, 483, 484, 487, 587, 589, 617
 Kornhuber, H. H., s. Kamei, T. 200, 201, 204, 231
 Kornhuber, H. H., s. Von Kongehl, G. 56, 57, 153
 Kornhuber, H. H., s. Lange, G. 204, 231, 454, 461, 483, 484, 487
 Kottenhoff, H., Lindahl, L. 119, 146
 Kowalsky, N., s. Melvill Jones, G. 45, 52, 53, 54, 148, 283, 296, 319
 Kowalsky, W., s. Jones, G. M. 429, 447

- Kragh, J. 269, 271, 279
 Kranz, G., s. Collins, W. E. 547, 574
 Kreidl, A. 95, 147, 358, 405, 410, 447, 470, 487
 Krejcova, s. Kornhuber, H. H. 591
 Kriebel, J., s. Bechinger, D. 196, 229
 Krieger, H. P., s. Pollack, M. 365, 368
 Krijger, R. 406, 408, 410, 425, 448
 Kurashvili, A. Ye., Babiyak, V. P. 303, 318
 Kurihara, M., s. Takebayshi, H. 354
 Kuriyama, T., s. Takebayshi, H. 354
 Kuroda, W., s. Tokita, T. 355
 Kurosawa, R., s. Hinoki, M. 437, 446
 Kuypers, H. G. J. M., Lawrence, D. G. 612, 618
 Kuypers, H. G. J. M., s. Pandya, D. N. 600, 610, 612, 619
 Van der Laarse, W. D., s. Oosterveld, W. J. 298, 302, 304, 306, 319
 Lachman, J., Aarons, L., Erikson, J. H. 365, 367
 Lahey, M. E., s. Bray, P. F. 213, 229
 Lane, H. L., s. Curran, C. R. 181, 187
 Lange, B. 477, 478, 487
 Lange, G., Kornhuber, H. H. 204, 231, 454, 461, 483, 484, 487
 Langelaan, J. W. 426, 448
 Langova, J. 356
 Lansberg, M. P. 77, 78, 106, 120, 126, 147
 Lansberg, M. P., Guedry, F. E., Jr., Graybiel, A. 256, 264, 300, 302, 318, 550, 577
 Larsen, E. M., s. Hellebrandt, F. A. 360
 Lashley, K. S., s. Clark, G. 612, 616
 Latto, R., Cowey, A. 612, 618
 Lauer, E. W., s. Crosby E. C. 7, 8, 141
 Laurell, L., s. Aschan, G. M. 307, 315
 Laurens, H., Miles, A. 472, 487
 Lauver, L. S., s. Guedry, F. E. 44, 58, 59, 60, 145, 363, 367, 381, 386
 Lawrence, D. G., s. Kuypers, H. G. J. M. 612, 618
 Lebedev, V. I., s. Yuganov, E. M. 554, 556, 580
 Ledoux, A. 60, 62, 69, 147, 283, 284, 285, 287, 318, 452, 461
 Ledoux, A., Demanez, J. P. 222, 231
 Lee, F. S. 463, 487, 560, 577
 Leggenhager, K. 400, 403
 Leggett, A. L., s. Fisher, M. B. 355, 358
 Lehman, P., s. McEachern, D. 391, 399, 400, 401, 404
 Leiri, E. 413, 448
 Leonard, J. A. 358
 Letko, W., Stone, R. W. 554, 577
 Letko, W., s. Stone, R. W. 112, 113, 152, 544, 545, 546, 579
 Levin, P. M. 354, 482, 487
 Lewis, H. B., s. Witkin, H. A. 181, 190
 Licklider, J. C. R. 36, 147
 Lidvall, H. F. 362, 363, 367, 374, 378, 380, 381, 386, 406, 410, 411, 448
 Lilly, J. C. 609, 618
 Lindahl, L., s. Kottenhoff, H. 119, 146
 Lindeman, H. H. 69, 147, 290, 318
 Lindeman, H. H., s. Engström, H. 70, 142
 Lindholm, Ernest, Haygood, Robert, C. 573
 Lindsay, J. R., s. Fernández, C. 408, 410, 445
 Lindsley, D. B., Schreiner, L. H., Magoun, H. W. 478, 487
 Linschoten, J. 178, 188
 Liu, C. N., Chambers, W. W. 459, 461
 Liu, C. N., s. McCouch, G. P. 459, 461
 Liu, C. Y., s. McCouch, G. P. 459, 461
 Llinás, R., Precht, W. 607, 618
 Llinás, R., Wolfe, J. W. 599, 608, 618
 Llinás, R., s. Precht, W. 452, 461
 Loeb, J. 466, 487
 Löwenberg, D. 477, 487
 Lombrose, C. T., s. Duffy, F. H. 130, 141
 Long, G. M. 109, 110, 147
 De Long, M. R. 608, 618
 Lorente de Nó, R. 217, 231, 284, 309, 318, 428, 448, 451, 461, 469, 487, 590, 618
 Lorenz, K. 166, 188
 Lowenstein, O. 15, 60, 147, 165, 188, 282, 284, 285, 287, 318, 448, 466, 472, 487, 552, 553, 573, 577
 Lowenstein, O., Roberts, T. D. M. 18, 69, 71, 147, 163, 188, 283, 290, 319, 517, 518, 519, 520, 522, 524, 525, 526, 530, 531, 545, 559, 577
 Lowenstein, O., Sand, A. 283, 284, 319, 452, 461, 464, 487, 586, 618
 Lowenstein, O., Thornhill, R. A. 496, 577
 Lowenstein, O., s. Groen, J. J. 19, 59, 62, 144, 283, 317, 415, 423, 446, 502, 508, 509, 510, 511, 512, 518, 575
 Luciani, K. 477, 488
 Ludvigh, E., s. Miller, J. W. 130, 149
 Lüdtke, H. 465, 488
 Lumpkin, R. C. 371, 386
 Lundgren, A., s. Henriksson, N. G. 36, 145
 Luschei, E. S., s. Fuchs, A. F. 586, 590, 617
 Maanen, J. C. D. van 405, 406, 408, 409, 411, 426, 448
 MacCorquodale, K. 25, 147
 MacCorquodale, K., Meehl, P. E. 160, 188
 MacCorquodale, K., s. Clark, B. 25, 139
 MacCorquodale, K., s. Graybiel, A. 22, 143, 299, 317, 416, 434, 445
 Mach, E. 7, 17, 24, 25, 30, 31, 68, 74, 75, 76, 77, 78, 79, 95, 104, 147, 157, 319, 414, 416, 429, 435, 448
 Machover, K., s. Witkin, H. A. 181, 190
 MacKay, D. M. 156, 189, 197
 Maekawa, K., Simpson, J. E. 590, 604, 618

- Magnus, R. 68, *147*, 163, 178, *189*, 437, 451, 456, *461*, 464, 468, 469, 470, 471, 472, 473, 474, 475, 477, 478, 481, 482, *488*, *618*
- Magnus, R., De Kleyn, A. 464, 465, 471, 472, *488*
- Magnus, R., Storm van Leeuwen, W. 584, *618*
- Magnus, R., s. Kleyn, A. de 284, *318*
- Magoun, H. W., s. Lindsley, D. B. 478, *487*
- Mahoney, J. L., Harlan, W. L., Bickford, R. G. 362, *367*, 374, *386*
- Maitland, T. G. 400, *403*
- Makoto 516
- Malcolm, R., Melvill Jones, G. 42, 56, 60, 62, 64, *147*, 296, 306, *319*, 508, 509, 510, 512, 515, 516, 552, *577*
- Malecki, J. 427, *448*
- Mann, C. W. 24, 72, 84, 89, 90, 93, 94, 96, 110, *147*, 160, *189*, *354*
- Mann, C. W., Berry, N. 88, *147*
- Mann, C. W., Berthelov-Berry, N. H., Dauterive, H. J. 84, 86, 88, *147*
- Mann, C. W., Canella, C. J. 35, *147*
- Mann, C. W., Dauterive, H. J. 84, 88, *147*
- Mann, C. W., Guedry, F. E., Ray, J. T. 22, 117, *148*
- Mann, C. W., Passey, G. E. 72, 85, 88, *147*
- Mann, C. W., Passey, G. E., Ambler, R. K. 85, *148*
- Mann, C. W., Ray, J. T. 25, 26, 27, 72, 85, *147*
- Mann, L. *354*
- Manni, E., Giretti, M. L. 475, *488*
- Manni, E., s. Di Giorgio, A. M. 475, *485*
- Manning, G. 391, *404*
- Manning, G. W., Stewart, W. G. 390, *404*
- Manning, K. R., s. Bárány, J. W. *359*
- Mano, N., s. Baker, R. G. 458, *460*
- Marant, R. B., s. Wapner, S. 23, *153*
- Marchiafava, P. L., Pompeiano, O. 130, *148*
- Van der Mark, F., s. Collewijn, H. 587, *616*
- Markaryan, S. S. 292, 302, *319*
- Markham, C. H., Precht, W., Shimazu, H. 459, *461*
- Markham, C. H., s. Colbert, E. G. 365, *366*
- Markham, C. H., s. Precht, W. 452, 453, 454, 455, 456, 457, 458, 459, *461*, 465, 475, 479, *488*
- Markham, C. H., s. Ritvo, E. R. 365, *368*
- Marr, D. 604, *619*
- Marshall, J. E., Brown, J. H. 131, *148*, 365, *367*, 376, 377, 381, *387*
- Marshall, J. E., s. Brown, J. H. 370, *383*
- Martinez, A., s. Riesco-MacClure, J. S. 221, *232*
- Mason, A., s. Ritvo, E. R. 365, *368*
- Matheson, F. A., s. Sadoff, M. 25, 37, *151*
- Mathog, R. H., Cramer, R. L. 577
- Maurer, W., s. Meyer zum Gottesberge, A. 472, 483, *488*
- Maxwell, S. S. 165, *189*, 291, *319*
- Maxwell, S. S., Burke, U. L., Reston, C. 371, 372, 373, *387*
- Mayne, J. W., s. Johnston, W. H. 403, 607, *617*
- Mayne, R. 5, 6, 20, 22, 38, *148*, 281, *319*, 495, 501, 502, 507, 528, 529, 530, 533, 554, 555, 560, 566, 568, *577*, 585, *619*
- Mayne, R., Belanger, F. 517, 521, 522, 530, *577*
- Mayne, R., Mead, R. 566, *577*
- Mayne, R., s. Belanger, F. 29, *137*, *573*
- Mazuoka, U., s. Fukuda, T. 376, 377, *385*
- McCabe, B. F. 308, *319*, 376, *387*, *448*
- McCabe, B. F., Gillingham, K. 426, *448*
- McCabe, B. F., Ryu, J. H. 475, 479, 483, *488*
- McCabe, B. F., Ryu, I. H., Sekitani, T. 453, 459, *461*
- McClure, C. L. 496, *578*
- McClure, J. A. 399, *404*
- McClure, J. A., Fregly, A. R., Molina, E., Graybiel, A. 399, *404*
- McCollom, I. N., s. Seashore, R. H. *356*
- McCouch, G. P., Austin, G. M., Liu, C. N., Liu, C. Y. 459, *461*
- McDermid, C. D., s. Smith, K. U. *360*
- McDonough, R. C., s. Kennedy, R. S. 345, *352*
- McEachern, D., Morton, G., Lehman, P. 391, 399, 400, 401, *404*
- McFarland, J. H., Clarkson, F. 175, *188*
- McFarland, J. H., Wapner, S., Werner, H. 89, *148*
- McFarland, R. A., Franzen, R. *356*
- McGill, T. E., s. Vernon, J. A. *359*
- McIntyre, A. K. 586, *619*
- McLeod, M. E., Correia, M. J. 304, *319*
- McLeod, M. E., Meek, J. C. 324, *352*
- McLeod, M. E., s. Graybiel, A. 134, *143*, 235, *264*, 324, 333, 338, *352*, 567, *575*
- McMitchael, A. E., Graybiel, A. *578*
- McNally, W. H., Stuart, G. 389, *404*
- McNally, W. J. 68, *148*, 165, *189*
- McNally, W. J., Stuart, E. A. 7, 17, 68, 115, *148*
- McNally, W. J., Tait, J. 277, 279, 466, 488, 584, *619*
- McNally, W. J., s. Tait, J. 543, *579*
- McNally, W. S., s. McNaughton, I. P. S. 559, *578*
- McNaughton, I. P. S., McNally, W. S. 559, *578*
- Mead, R., s. Mayne, R. 566, *577*
- Meda, E. 120, *148*, 381, *387*, 392, *404*
- Meehl, P. E., s. MacCorquodale, K. 160, *188*
- Meek, J. C., Graybiel, A., Beischer, D. E., Riopelle, A. J. 427, *448*

- Meek, J. C., s. Graybiel, A. 575
 Meek, J. C., s. Johnson, W. H. 399, 403, 500, 576
 Meek, J. C., s. McLeod, M. E. 324, 352
 Meiry, J. L. 25, 27, 28, 30, 68, 71, 73, 74, 75, 79, 98, 148, 206, 223, 225, 231, 283, 319
 Meiry, J., s. Young, L. 71, 74, 154, 165, 190, 502, 524, 525, 530, 539, 546, 580
 Meissner, P. B., s. Witkin, H. A. 181, 190
 Mellström, A., s. Fluor, E. 69, 102, 142, 163, 165, 187, 235, 263
 Melvill Jones, G. 6, 20, 69, 71, 127, 148, 285, 319, 502, 527, 547, 553, 565, 573, 578
 Melvill Jones, G., Barry, W., Kowalsky, N. 45, 52, 53, 54, 148, 283, 296, 319
 Melvill Jones, G., Gonshor, A. 131, 148
 Melvill Jones, G., Milsum, J. H. 19, 38, 60, 148, 285, 319, 502, 510, 578
 Melvill Jones, G., Spells, K. E. 5, 38, 148, 502, 508, 578
 Melvill Jones, G., s. Benson, A. J. 111, 112, 116, 137, 288, 290, 316, 548, 549, 552, 553, 566, 567, 574
 Melvill Jones, G., s. Gonshor, A. 131, 143
 Melvill Jones, G., s. Malmcolm, R. 42, 56, 60, 62, 64, 147, 296, 306, 319, 508, 509, 510, 512, 515, 516, 552, 577
 Melvill Jones, G., s. Milsum, J. H. 290, 319
 Melvill Jones, G., s. Sugie, N. 579
 Mendel, L., s. Fluor, E. 374, 378, 385
 Menzio, P. 476, 488
 Mertens, R. A., Collins, W. E. 370, 371, 372, 373, 387
 Mertens, R. A., s. Collins, W. E. 376, 378, 380, 381, 384, 547, 574
 Mertz, W., s. Graybiel, A. 134, 143, 338, 352, 567, 575
 Meshman, V. F. 130, 149
 Mettler, F. A. 608, 611, 619
 Metzger, W. 166, 173, 179, 189
 Meyer, D. L., s. Schaefer, K. P. 469, 473, 474, 476, 478, 480, 481, 482, 488
 Meyer zum Gottesberge, A., Maurer, W. 472, 483, 488
 Meyer zum Gottesberge, A., Plester, D. 165, 189
 Michael, J., Jones, G. M. 589, 619
 Mickle, W., Ades, H. 7, 8, 149
 Miehle, A. 206, 231
 Milbled, G., s. Nayrac, P. 356
 Miles, A., s. Laurens, H. 472, 487
 Miles, W. R. 276, 279, 356
 Miller, E. F. II. 159, 163, 185, 189, 234, 235, 239, 240, 264, 324, 333, 352, 525, 526, 531, 578
 Miller, E. F., Fregly, A. R., Van den Brink, G., Graybiel, A. 86, 94, 149, 241, 264
 Miller, E. F., Fregly, A. R., Graybiel, A. 93, 94, 95, 96, 149, 241, 264, 325, 352
 Miller, E. F., Graybiel, A. 86, 93, 94, 100, 149, 159, 164, 165, 175, 179, 189, 234, 235, 239, 240, 241, 242, 251, 257, 259, 262, 264, 265, 324, 330, 333, 338, 352, 525, 526, 578
 Miller, E. F., Graybiel, A., Kellogg, R. S. 103, 149, 239, 240, 265
 Miller, E. F. II., Graybiel, A., Kellogg, R. S., O'Donnell, R. D. 252, 257, 262, 265
 Miller, E. F. II., Pulec, J. L., Wilcox, J. G., Graybiel, A. 235, 265
 Miller, E. F., s. Graybiel, A. 75, 91, 96, 103, 104, 134, 143, 164, 187, 234, 235, 237, 242, 244, 247, 256, 257, 259, 261, 262, 263, 264, 567, 575
 Miller, G. A. 57, 58, 149
 Miller, J. W., Goodson, J. E. 119, 120, 149
 Miller, J. W., Ludvigh, E. 130, 149
 Miller, N. E. 572, 578
 Milojevic, B. 200, 231
 Milojevic, B., Voots, R. J. 304, 319
 Milojevic, B., Watson, J. L. 273, 279, 354
 Milsum, J. H., Melvill Jones, G. 290, 319
 Milsum, J. H., s. Melvill Jones, G. 19, 38, 60, 148, 285, 319, 502, 510, 578
 Milton, J. L., s. Jones, R. E. 85, 146
 Minners, H. A., Douglas, W. K., Knoblock, E. C., Graybiel, A., Hawkins, W. R. 358
 Minners, H. A., White, S. C., Douglas, W. K., Knoblock, E. C., Graybiel, A. 358
 Minsky, M. 578
 Mishkin, M., s. Teuber, H. L. 8, 152
 Misovich, M., s. Morant, R. B. 162, 189
 Mitchell, R. E., s. Fregly, A. R. 324, 351
 Mittelstaedt, H. 164, 173, 189, 465, 488
 Mittelstaedt, H., s. Holst, E. von 156, 158, 169, 188, 416, 426, 446, 584, 617
 Mittermaier, R. 428, 433, 434, 448, 451, 461, 464, 483, 488
 Miyata, H., s. Fukuda, T. 376, 377, 385
 Mizutani, T., s. Tokita, T. 355
 Moffet, R., s. Spiegel, E. A. 8, 152
 Molina, E., s. McClure, J. A. 399, 404
 Molinari, J. A., s. Arslan, M. 8, 136, 475, 484
 Money, K. E. 310, 319, 389, 391, 399, 401, 404, 550, 551, 568, 569, 573, 578
 Money, K. E., Friedberg, J. 399, 400, 404, 407, 411, 448
 Money, K. E., Johnson, W. H., Corlett, B. M. A. 285, 288, 308, 319
 Money, K. E., Scott, J. W. 308, 319, 543, 544, 561, 578
 Money, K. E., Sokoloff, M., Weaver, R. S. 319
 Money, K. E., Wood, J. D. 126, 149
 Money, K. E., s. Correia, M. J. 112, 140, 312, 316, 551, 574
 Money, K. E., s. Nito, Y. 319
 Monnier, M., s. Montandon, P. 130, 149
 Monrad-Krohn, G. H. 354

- Montague, E. K., s. Guedry, F. E. 120, 123, 124, 145, 378, 380, 386, 527, 554, 576
- Montandon, A., Russbach, A. 25, 149, 223, 231
- Montandon, P., Monnier, M. 130, 149
- Montandon, W. 405, 411, 420, 448
- Moore, J. W., s. Pezzoli, J. A. 360
- Morant, R. B., Aronoff, J. C. 160, 189
- Morant, R. B., Beller, H. K. 169, 189
- Morant, R. B., Harris, J. 162, 189
- Morant, R. B., Misovich, M. 162, 189
- Morimoto, M. 319
- Morrison, A. R., Pompeiano, O. 130, 149
- Morsh, J. E. 357
- Morsh, J. R. 357
- Mortag, H. G., s. Schöne, H. 99, 100, 105, 106, 151, 163, 165, 190
- Morton, D. J. 360
- Morton, G., s. McEachern, D. 391, 399, 400, 401, 404
- Moruzzi, G., s. Batini, C. 478, 481, 484
- Moss, F. S. 357
- Mountcastle, V. B., s. Bard, P. 607, 615
- Mountcastle, V., s. Walzi, E. 7, 8, 153
- Moushegian, G., s. Rupert, A. 452, 461
- Mowrer, O. H. 27, 118, 149, 361, 362, 367, 371, 373, 375, 376, 387, 452, 461, 464, 488
- Mowrer, O. H., s. Fearing, F. S. 361, 367, 373, 384
- Mowrer, O. H., s. Gibson, J. J. 109, 119, 142, 160, 162, 187
- Müller, G. E. 86, 149, 160, 161, 175, 189, 241, 265
- Mulder, W. 30, 149, 415, 448
- Muskens, L. J. J. 217, 231, 413, 448
- Mustian, V. M., s. Farmer, T. W. 353
- Myers, G. G., s. Bray, P. F. 213, 229
- Mygind, S. H. 68, 149, 269, 279
- Myklebust, H. R. 359
- Nagel, James 7
- Nagel, W. A. 89, 149
- Nakayama, S., s. Tokita, T. 355
- Nashner, L. M. 251, 265, 360
- Nauta 612
- Naylor, G. F. 160, 189
- Naylor, G. F. K. 189
- Nayrac, P., Milbled, G., Parquet, Ph. J. 356
- Neal, M. 6, 149
- Nelson, J. G. 88, 90, 149
- Nelson, J. R. 333, 352
- Newell, A. 578
- Newell, F. W., s. Chow, K. L. 211, 229
- Newsom, B. D., Brady, J. F., Goble, G. J. 354, 359
- Newsom, B. D., Brady, J. F., Shafer, W. A., French, R. S. 354
- Newsom, B., s. Graybiel, A. 91, 96, 143, 164, 187, 237, 247, 256, 264
- Nieuwenhuysen, J. H. 405, 406, 407, 411, 426, 448
- Nieuwenhys, R. 582, 619
- Nijhoff, P., s. Van Dishoeck, H. A. E. 8, 22, 35, 117, 153, 380, 384, 416, 444, 579
- Nijhoff, P., s. Roggeveen, L. J. 25, 35, 151
- Nilsson, A., Henriksson, N. G. 36, 150
- Nilsson, A., s. Andersson, S. 36, 110, 136
- Nilsson, A., s. Henriksson, N. G. 36, 145
- Nisimaru, N., s. Ito, M. 586, 617
- Nito, Y., Johnson, W. H., Money, K. E., Ireland, P. E. 319
- Niven, J. I., Graybiel, A. 354, 472, 483, 488
- Niven, J. I., Hixson, W. C. 66, 150
- Niven, J. I., Hixson, W. C., Correia, M. J. 75, 77, 106, 111, 150, 308, 310, 311, 319, 391, 404, 506, 561, 578, 579
- Niven, J. I., Whiteside, T. C. D., Graybiel, A. 262, 265
- Niven, J. I., s. Brown, R. H. 23, 138
- Niven, J. I., s. Correia, M. J. 98, 99, 100, 101, 103, 140, 164, 165, 186
- Niven, J. I., s. Graybiel, A. 299, 317, 416, 434, 445
- Niven, J. I., s. Hixson, W. C. 10, 12, 13, 15, 66, 120, 128, 146, 502, 507, 576
- Niven, J. I., s. Whiteside, T. D. M. 35, 154, 256, 266
- Nixon, C. W., Harris, C. S., von Gierke, H. E. 359
- Noble, R. L. 389, 390, 391, 404
- Noble, R. L., Taylor, N. B. J. 393, 404
- Norman, J. W., s. Guedry, F. E. 44, 47, 48, 49, 51, 52, 56, 58, 60, 63, 64, 108, 145
- Northington, P. 482, 488
- Northington, P., Barrera, S. E. 471, 472, 488
- Nyberg, J. W., s. White, W. J. 359
- Nyby, O., Jansen, J. 602, 619
- Nylen, C. O. 204, 231
- Nylén, C. O., s. Aschan, G. 29, 136, 429, 430, 443
- Nyman, H. 270, 277, 279
- Obata, K., s. Ito, M. 587, 605, 617
- Oberman, A., s. Fregly, A. R. 324, 351
- O'Donnell, R. D., s. Miller, E. F. II. 252, 257, 262, 265
- Östlund, H., s. Henriksson, N. G. 276, 279, 360
- Ohm, J. 210, 231
- Ohwaki, S. 160, 189
- Okubu, K., s. Owada, K. 320
- Olsson, L. G., s. Henriksson, N. G. 276, 279, 360
- Oman, C. M., s. Young, L. 42, 56, 64, 154, 296, 306, 320, 509, 515, 516, 580
- Omwake, K. T. 357
- Onesto, N., s. Braitenberg, V. 604, 616
- Oosterveld, W. J. 307, 319
- Oosterveld, W. J., Van der Laarse, W. D. 298, 302, 304, 306, 319
- Oosterveld, W. J., s. Janeke, J. B. 302, 317
- Oppenheimer, E. 179, 189
- Orias, O., s. Bard, P. 610, 615
- Orlov, I. V., s. Kislyakov, V. A. 318
- Orma, E. J. 356

- Ornitz, E. M. 6, 126, 150, 365, 368
- Ornitz, E. M., s. Ritvo, E. R. 365, 368
- Osterhammel, P., Terkildsen, K., Zilstorff, K. 375, 376, 377, 387
- Osypka, P., s. Von Diringshofen, H. 25, 153
- Outerbridge, J. S. 19, 29, 59, 150
- Owada, K., Okubu, K. 320
- Owada, K., Shiizu, S., Kimura, K. 320
- Owen, E. P., s. Ross, H. E. 91, 151
- Owens, G. G., s. Guedry, F. E. 44, 47, 48, 49, 51, 52, 56, 58, 60, 63, 64, 108, 145
- Padden, D. A. 90, 150
- Paine, R. S., s. Pendleton, M. E. 362, 368
- Pandya, D. N., Kuypers, H. G. J. M. 600, 610, 612, 619
- Parker, D. E., s. Schöne, H. 99, 100, 103, 151, 163, 165, 190
- Parker, D. M. 120, 150
- Parquet, Ph. J., s. Nayrac, P. 356
- Parsons, R. D. 40, 41, 42, 43, 50, 56, 63, 150
- Pasik, P., Pasik, T. 216, 218, 232, 612, 619
- Pasik, P., Pasik, T., Bender, M. B. 217, 232
- Pasik, P., s. Pasik, T. 216, 232
- Pasik, T., Pasik, P. 216, 232
- Pasik, T., s. Pasik, P. 216, 217, 218, 232, 612, 619
- Passey, G. E. 88, 150, 160, 189
- Passey, G. E., Guedry, F. E. 72, 85, 150
- Passey, G. E., s. Mann, C. W. 72, 85, 88, 147, 148
- Patterson, John, D. 573
- Patterson, J. L., s. Graybiel, A. 81, 85, 143, 247, 252, 264
- Pearson, R. G., Hauty, G. T. 72, 85, 150
- Peiper, A. 123, 150
- Peitersen, E. 273, 274, 275, 279, 354, 355
- Peitersen, E., Zilstorff-Pedersen, K. 272, 274, 275, 276, 280, 355
- Peitersen, E., s. Zilstorff-Pedersen, K. 273, 274, 280, 355
- Pendleton, M. E., Paine, R. S. 362, 368
- Penfield, W. 7, 8, 150, 438, 448
- Penman, K. A. 356
- Perlman, H. B. 165, 189
- Perlman, H. B., s. Johner, C. H. 353, 365, 367
- Perlmutter, L. C., s. Kimble, G. A. 5, 135, 146
- Perrin, F. A. C. 359
- Peters, G., s. Thauer, R. 466, 467, 473, 480, 489
- Peterson, B. W. 452, 461
- Peto, A. 6, 126, 150
- Pezzoli, J. A., Moore, J. W. 360
- Pfaltz, C. R., Arx, S. V. 378, 387
- Pfaltz, C. R., Kamath, R. 451, 461
- Pfaltz, C. R., s. Hood, J. F. 362, 367, 373, 386
- Pfeiffer, Henry, March 573
- Philipszoon, A. J. 410, 411, 414, 448
- Philipszoon, A. J., s. Bos, J. H. 316, 410, 410, 437, 444
- Philipszoon, A. J., s. Jongkees, L. B. W. 234, 258, 264, 308, 318, 364, 367, 447
- Picart, P., s. Greiner, G. F. 223, 230
- Pichler, H. J. 424, 448
- Pike, F. H., s. Wilson, T. G. 468, 490
- Pilz, G. F. 371, 387
- Plattig, s. Keidel 596, 603, 606
- Plester, D., s. Meyer zum Gottesberge, A. 165, 189
- Ploog, D. 612, 619
- Poe, R. H., s. Collins, W. E. 365, 366
- Pollack, M., Krieger, H. P. 365, 368
- Pollak 7
- Pollak, J. 405, 411, 448
- Polyakov, B. I., s. Arlaschenko, N. I. 353
- Pompeiano, O. 268, 280
- Pompeiano, O., Barness, C. D. 585, 619
- Pompeiano, O., Brodal, A. 268, 280
- Pompeiano, O., s. Barness, C. D. 585, 615
- Pompeiano, O., s. Batini, C. 478, 481, 484
- Pompeiano, O., s. Brodal, A. 268, 278, 565, 574
- Pompeiano, O., s. Marchiafava, P. L. 130, 148
- Pompeiano, O., s. Morrison, A. R. 130, 149
- Popov, A. P. 300, 320
- Popov, N. I., s. Yuganov, E. M. 554, 556, 580
- Portman, G. 561, 579
- Portman, M. 579
- Posner, J. B., s. Collins, W. E. 362, 363, 366, 375, 384
- Poulton, E. C. 40, 150
- Powell, T. J. 554, 579
- Powell, T. P. S., s. Jones, E. G. 600, 610, 617
- Powell, T. P. S., s. Kemp, J. M. 602, 617
- Preber, L. 378, 387, 406, 411, 448
- Preber, L., s. Behr, K. 444
- Precht, W., Grippo, J., Richter, A. 458, 461
- Precht, W., Linás, R., Clarke 452, 461
- Precht, W., Richter, A., Grippo, A. 458, 461
- Precht, W., Shimazu, H. 459, 461
- Precht, W., Shimazu, H., Markham, C. H. 452, 453, 454, 455, 456, 457, 458, 459, 461, 465, 475, 479, 488
- Precht, W., s. Linás, R. 607, 618
- Precht, W., s. Markham, C. H. 459, 461
- Precht, W., s. Shimazu, H. 60, 151, 290, 320, 452, 453, 454, 457, 459, 462, 464, 489
- Prescott, J. W. 6, 126, 150
- Pribram, K. H. 611, 619
- Price, R. H. 36, 150
- Proctor, D. F. 400, 404
- Proctor, L. R., Fernández, C. 370, 373, 387
- Pruyser, P. W. 573
- Pulec, J. L., s. Miller, E. F. II. 235, 265
- Purkinje, J. E. 119, 150, 267, 280, 291, 320, 408, 411, 449
- Quix, F. H. 17, 68, 80, 150, 405, 406, 411, 435, 436, 449
- Quix, F. H., Eijsvogel, M. H. 182, 189

- Raaschov, F., s. Brun, E. 393, 403
- Rademaker, G. G. J. 354, 584, 619
- Rademaker, G. G. J., Garcin, R. 277, 280, 584, 619
- Rådmark, K. 277, 280
- Radner, M., s. Gibson, J. J. 160, 162, 169, 187
- Raikovits, K., s. Szentágothai, J. 475, 489
- Rashbass, C. 590, 619
- Ratliff, F., Riggs, L. A. 199, 232
- Ratner, S. C. 382, 387
- Rauch, S. 507, 579
- Rawlinson, H. E. 400, 404
- Ray, J. T., s. Mann, C. W. 22, 25, 26, 27, 72, 85, 117, 147, 148
- Reason, J. T. 36, 120, 150
- Reason, J. T., Benson, A. J. 36, 150
- Reason, J. T., Diaz, E. 120, 125, 132, 150
- Reason, J. T., Graybiel, A. 110, 120, 123, 131, 133, 151
- Reason, J. T., s. Benson, A. J. 36, 137, 365, 366
- Reason, J. T., s. Dearnaley, E. J. 378, 384
- Reding, G. R., Fernández, C. 261, 265
- Reston, C., s. Maxwell, S. S. 371, 372, 373, 387
- Reynolds, B. 357
- Rhodes, J. M., s. Adey, W. R. 261, 263
- Ricaldoni, M. A. 357
- Ricciuti, E. A., s. Alexander, S. J. 262, 263
- Rice, N., s. Collins, W. E. 547, 574
- Richmond, G., s. Guedry, F. E. 27, 28, 145
- Richter, A., s. Precht, W. 458, 461
- Ricks, E. L., s. Graybiel, A. 342, 352
- Riddle, K. S., s. Hellebrandt, F. A. 360
- Riesco-MacClure, J. S., Martinez, A. 221, 232
- Riesen, A. H. 211, 232
- Riesen, A. H., s. Chow, K. L. 211, 229
- Riggs, L. A., s. Ratliff, F. 199, 232
- Riopelle, A. J., s. Graybiel, A. 575
- Riopelle, A. J., s. Meek, J. C. 427, 448
- Ritvo, E. R., Ornitz, E. M., Eviatar, A., Markham, C. H., Brown, M. B., Mason, A. 365, 368
- Roberts, T. D. M. 18, 95, 151
- Roberts, T. D. M., s. Lowenstein, O. 18, 69, 71, 147, 163, 188, 283, 290, 319, 517, 518, 519, 520, 522, 524, 525, 526, 530, 531, 545, 559, 577
- Robinson, D. A. 586, 587, 588, 589, 590, 591, 592, 604, 612, 619
- Robinson, D. A., Fuchs, A. F. 592, 612, 619
- Robinson, D. A., s. Keller, E. L. 586, 617
- Robinson, D. A., s. Ron, S. 591, 599, 619
- Robinson, D. A., s. Skavenski, A. A. 589, 620
- Rocker, M., s. Von Baumgarten, R. J. 580
- Roggeveen, L. J., Nijhoff, P. 25, 35, 151
- Rohrer, F. 58, 151
- Roman, A. J., Warren, B. H., Graybiel, A. 298, 320
- Romberg, M. H. 276, 280, 354
- Romel, E. L., s. Babskii, E. B. 359
- Ron, S., Robinson, D. A. 599, 619
- Ron, S., Robinson, D. A., Skavenski, A. A. 591, 619
- Rosenberg, J., s. Fujita, Y. 452, 460
- Rosenblueth, A., s. Cannon, W. B. 459, 460
- Ross, B. M., s. Engen, T. 40, 141
- Ross, D. A. 283, 284, 320
- Ross, H. E., Crickmar, S. D., Sills, N. V., Owen, E. P. 91, 151
- Ross, J. A. 452, 461
- Rossum, A. van 408, 411, 429, 432, 449
- Rupert, A., Moushegian, G., Galambos, R. 452, 461
- Ruppert, J. 361, 368, 369, 387
- Rushmer, R. F. 397, 404
- Russbach, A., s. Montandon, A. 25, 149, 223, 231
- Russel, I. S. R. 481, 482, 488
- Russell, P. E. 573
- Ruttin, E. 435, 449, 472, 483, 488
- Ruuth, E., s. Andersson, S. 36, 110, 136
- Ryu, I. H., s. McCabe, B. F. 453, 459, 461, 475, 479, 483, 488
- Sadoff, M., Matheson, F. A., Havill, C. D. 25, 37, 151
- Saito, I., Wada, H., Yagura, S., Kato, N. 310, 320
- Sala, O. 285, 320, 373, 387
- Sand, A., s. Lowenstein, O. 283, 284, 319, 452, 461, 464, 487, 586, 618
- Sandström, J. 205, 207, 232
- Sasaki, K. 458, 461
- Sato, G., s. Spiegel, E. A. 451, 458, 462
- Sato, T., s. Kitahara, M. 357
- Sattler, C. H., Blohmke, A. 211, 232
- Scanlon, S. L., Goetzinger, C. P. 359
- Schaefer, K. P. 458, 461
- Schaefer, K. P., Meyer, D. L. 469, 473, 474, 476, 478, 480, 481, 482, 488
- Schaefer, K. P., Wehner, H. 482, 488
- Schaefer, K. P., s. Dal Ri, H. 479, 481, 485
- Schaefer, K. P., s. Duensing, F. 69, 141, 287, 317, 452, 453, 454, 460, 464, 469, 484, 485, 586, 590, 616
- Schaltenbrand, G., Cobb, S. 476, 489
- Scheerer, E., s. Bischoff, N. 117, 137, 159, 160, 161, 169, 170, 174, 176, 177, 178, 180, 184, 185, 186
- Scheid, P., s. Deecke, L. 600, 616
- Scheid, P., s. Fredrickson, J. 8, 142
- Schierbeek, P. 406, 411, 430, 449
- Schierbeek, P., s. De Vries, H. I. 25, 141
- Schilder, P. 6, 151

- Schillcr, P. H. 217, 232, 612, 619
- Schiller, P. H., Körner, F. 604, 619
- Schilpp, P. A. 104, 151
- Schlager, M., s. Bechinger, D. 196, 229
- Schmaltz, G. 222, 232, 419, 434, 449, 502, 506, 579
- Schmidt 79
- Schmidt, s. Kornhuber, H. H. 591
- Schmidt, C. L., Wist, E. R., Diehgans, J. 607, 620
- Schmidt, C. L., s. Klinke, R. 119, 146
- Schmidt, R., s. Fernández, C. 370, 385
- Schmidt, R. S. 285, 320, 607, 619
- Schmitt, F. O., Worden, F. G. 602, 606, 607, 611, 613
- Schneider, C. W., Bartley, S. H. 163, 190
- Schock, G. J. D. 248, 265
- Schoen, L. 69, 151, 452, 461, 464, 466, 472, 489
- Schöne, H. 68, 86, 91, 92, 93, 94, 98, 99, 100, 103, 109, 151, 159, 160, 163, 164, 165, 182, 190, 235, 241, 265, 435, 449, 465, 489
- Schöne, H., Mortag, H. G. 105, 106, 151
- Schöne, H., Parker, D. E. 99, 100, 103, 151, 165, 190
- Schöne, H., Parker, D. E., Mortag, H. G. 99, 100, 151, 163, 165, 190
- Schöne, H., Udo de Haes, H. 72, 85, 100, 109, 125, 151, 160, 163, 164, 165, 175, 182, 190
- Schöne, H., s. Udo de Haes, H. 92, 109, 153, 163, 175, 179, 182, 190, 294, 320
- Schreiber, L. H., s. Lindsley, D. B. 478, 487
- Schroeder, D. J. 365, 368, 378, 379, 387
- Schroeder, D. J., Gilson, R. D., Guedry, F. E., Collins, W. E. 130, 151
- Schroeder, D. J., s. Collins, W. E. 130, 140, 376, 381, 384, 547, 574
- Schroeder, D. J., s. Gilson, R. D. 130, 142
- Schubert, G. 120, 151, 408, 411, 449
- Schubert, G., s. Bornschein, V. H. 120, 137
- Schubert, G., s. Brecher, G. A. 160, 186
- Schuknecht, H. F. 291, 320
- Schuknecht, H. F., s. Graybiel, A. 235, 264, 324, 333, 352
- Schuster, E. H. J., s. Corvera, J. 17, 140
- Schwab, R. S. 401, 404
- Schwam, W. J., s. Crampton, G. H. 362, 367, 373, 384
- Schwartz, R. P., Vaeth, W. 360
- Schwarz, D., s. Fredrickson, J. M. 72, 142, 159, 230, 287, 317, 584, 609, 616
- Schwickhart, s. Titov 557
- Scolley, C. M. 249, 265
- Scollo-Lavizzari, G., Akert, K. 612, 620
- Scott, J. W., s. Money, K. E. 308, 319, 543, 544, 561, 578
- Sears, C. W., s. Jackson, M. M. 298, 317
- Seashore, H. G. 356, 357, 359
- Seashore, H. G., Koch, G. 354
- Seashore, R. H. 356
- Seashore, R. H., Buxton, C. E., McCollom, I. N. 356
- Segundo, J. P., s. Fujita, Y. 452, 460
- Sekitani, T., s. McCabe, B. F. 453, 459, 461
- Sellers, E. A., s. Taylor, W. J. R. 393, 397, 404
- Selye, H. 571, 579
- Semmes, J., Winestein, S., Ghent, L., Teuber, H. L. 8, 151
- Shafer, W. A., s. Newsom, B. D. 354
- Shames, I. H. 13, 151
- Shanzer, S., s. Bender, M. B. 216, 217, 229, 590, 615
- Sharpless, S. K. 135, 151
- Sheffey, P. L., s. Guedry, F. E. 118, 145, 363, 365, 367, 374, 378, 379, 381, 386
- Sherrington, C. S. 579
- Shideman, F. E., s. Smith, K. U. 360
- Shiizu, S., s. Owada, K. 320
- Shillinger, G. L., s. Von Baumgarten, R. J. 558, 559, 560, 580
- Shimazu, H., Precht, W. 60, 151, 290, 320, 452, 453, 454, 457, 459, 462, 464, 489
- Shimazu, H., s. Baker, R. G. 458, 460
- Shimazu, H., s. Markham, C. H. 459, 461
- Shimazu, H., s. Precht, W. 452, 453, 454, 455, 456, 457, 458, 459, 461, 465, 475, 479, 488
- Shiraki, T., s. Tokita, T. 355
- Shubert, E. 85, 151
- Silfverskiold, D. F., s. Behr, K. 444
- Sills, N. V., s. Ross, H. E. 91, 151
- Simpson, J. E., s. Maekawa, K. 590, 604, 618
- Sinecori 119
- Singleton, G. T. 115, 126, 151, 425, 449
- Sirkis, Murray, D. 573
- Sjöberg, A. A. 262, 265, 405, 411, 449, 555, 579, 607, 620
- Skavenski, A. A., Robinson, D. A. 589, 620
- Skavenski, A. A., s. Ron, S. 591, 619
- Skoglund, J. E. 356
- Slater-Hammel, A. T. 357
- Smith, A. H., s. Winget, C. M. 370, 373, 388
- Smith, C. R. 330, 352
- Smith, C. R., s. Graybiel, A. 261, 262, 264, 333, 352
- Smith, G., s. Andersson, S. 36, 110, 136
- Smith, K. U., Greene, D. 360
- Smith, K. U., McDermid, C. D., Shideman, F. E. 360
- Smith, K. U., Smith, W. M. 6, 134, 152
- Smith, M. J., s. Fregly, A. R. 322, 333, 338, 351
- Smith, P., s. Chinn, H. 389, 403
- Smith, S. Y., s. Coats, A. C. 304, 305, 316
- Smith, W. M., s. Smith, K. U. 6, 134, 152
- Smythies, J. R. 126, 152
- Snider, R. S., s. Bard, P. 607, 615
- Sokoloff, M., s. Money, K. E. 319

- Sokolovski, A. 365, 368, 429, 449
- Solodovnik, F. A., s. Yuganov, E. M. 554, 556, 580
- Solomon, G. E., Chutorian, A. M. 213, 232
- Sommer, H. S., s. Harris, C. S. 358
- Soulairac, A., Baron, J. B. 356
- Spamer, C. 463, 464, 465, 477, 489
- Speers 503
- Spells, K. E. 289, 320
- Spells, K. E., s. Melvill Jones, G. 5, 38, 148, 502, 508, 573, 585, 617
- Spiegel, E. A. 392, 404, 477, 489
- Spiegel, E. A., Aronson, L. 477, 489
- Spiegel, E. A., Dèmetriades, T. D. 451, 456, 462, 475, 489
- Spiegel, E. A., Egyed, J., Szekely, E. 8, 152
- Spiegel, E. A., Sato, G. 451, 458, 462
- Spiegel, E. A., Szekely, E. G., Moffet, R. 8, 152
- Spiegel, E. A., Teschler, L. 477, 489
- Spoendlin, H. H. 17, 69, 152, 290, 320, 515, 517, 518, 579
- Spoor, A., s. Van Dishoeck, H. A. E. 8, 22, 35, 117, 153, 380, 384, 416, 444, 579
- Sprague, J. M., Chambers, W. W. 478, 489
- Sprague, J. M., s. Chambers, W. W. 478, 485
- Stahle, J. 291, 294, 296, 320
- Stahle, J., s. Aschan, G. 29, 136, 200, 229, 429, 430, 443
- Stark, G. 223, 225, 232
- Stark, L., Vossius, G., Young, L. R. 589, 620
- Stark, L., s. Young, L. R. 587, 594, 620
- Stavraky, G. W., s. Drake, C. G. 459, 460
- St.-Cyr, G. J., Fender, D. H. 589, 620
- Steele, J. E. 120, 123, 152, 401, 404
- Steen, B., s. Jonsson, R. 360
- Steer, R. W. 112, 152, 507, 510, 548, 550, 552, 579
- Steer, R. W., Jr. 288, 310, 311, 320
- Stein, S. von 277, 280, 357
- Steiner, F. A., s. Weber, G. 586, 620
- Steinhausen, W. 69, 70, 71, 152, 415, 449, 502, 504, 513, 579
- Stenger, H. H. 204, 206, 232, 437, 449, 451, 458, 462, 482, 483, 484, 489
- Sternfeld, s. Benson, A. J. 312
- Stetson, R. H., s. Hubbard, A. W. 360
- Stevens, S. S. 39, 43, 152
- Stewart, J. D., s. Clark, B. 23, 25, 26, 27, 28, 30, 35, 42, 55, 58, 59, 63, 117, 139, 380, 383
- Stewart, W. G., s. Manning, G. W. 390, 403
- Stigler, R. 88, 91, 93, 152, 164, 190
- Stockwell, C. W., Gilson, R. D., Guedry, F. E. 65, 152
- Stockwell, C. W., Guedry, F. E. 108, 109, 110, 152, 256, 265
- Stockwell, C. W., Turnipseed, G. T., Guedry, F. E. 311, 320
- Stockwell, C. W., s. Gilson, R. D. 56, 62, 131, 142
- Stockwell, C. W., s. Graybiel, A. 234, 262, 264
- Stockwell, C. W., s. Guedry, F. E. 44, 45, 47, 48, 51, 52, 53, 56, 108, 145
- Stone, R. W., Letko, W. 112, 113, 152, 544, 545, 546, 579
- Stone, R. W., s. Letko, W. 554, 577
- Storm van Leeuwen, W., s. Magnus, R. 584, 618
- Struppler, A., s. Wigand, M. E. 276, 280
- Stuart, E. A., s. McNally, W. J. 7, 17, 68, 115, 148
- Stuart, G., s. McNally, W. H. 389, 404
- Stubbs, R. A., s. Johnson, W. H. 390, 391, 392, 403, 558, 576
- Stuteville, P., s. Welch, K. 612, 620
- Suganuma, Y., s. Tokita, T. 355
- Sugie, N., Melvill Jones, G. 579
- Sunahara, F. A., Johnson, W. H., Taylor, N. B. G. 393, 404, 408, 411, 449
- Sutherland, N. S. 162, 190
- Suzuki, J., Totsuka, G. 374, 387
- Suzuki, J., s. Cohen, B. 586, 616
- Swets, J. A. 36, 152
- Szekely, E., s. Spiegel, E. A. 8, 152
- Szentágothai, J. 69, 152, 165, 190, 232, 291, 320
- Szentágothai, J., Raikovits, K. 475, 489
- Szentágothai, J., s. Eccles, J. C. 604, 616
- Tait, J. 165, 190, 277, 280
- Tait, J., McNally, W. J. 543, 579
- Tait, J., s. McNally, W. J. 277, 279, 466, 488, 584, 619
- Takebayashi, H., Kuriyama, T., Imamura, H., Kurihara, M., Kishi, M. 354
- Takemori, S., s. Cohen, B. 116, 119, 125, 126, 140
- Takeuchi, T., s. Tokita, T. 355
- Talpis, L. 270, 280
- Tashiro, K., s. Fukuda, T. 376, 377, 385
- Taub, E. 134, 135, 152
- Taub, E., Berman, A. J. 134, 152
- Taylor, N. B. J., Hunter, J., Johnson, W. H. 401, 404
- Taylor, N. B., s. Best, C. H. 400, 403
- Taylor, N. B. J., s. Johnson, W. H. 390, 403
- Taylor, N. B. J., s. Noble, R. L. 393, 404
- Taylor, N. B. G., s. Sunahara, F. A. 393, 404, 408, 411, 449
- Taylor, W. J. R., Johnson, W. H., Sellers, E. A. 393, 397, 404
- Templeton, W. B., s. Howard, I. P. 7, 17, 72, 82, 86, 94, 95, 117, 119, 120, 146, 160, 165, 178, 188
- Ten Kate, J. H. 59, 152
- Ter Braak, J. W. G. 284, 320
- Terins, J. 185, 190
- Terkildsen, K., s. Osterhammel, P. 375, 376, 377, 387
- Teschler, L., s. Spiegel, E. A. 477, 489
- Teuber, H. L. 7, 8, 52, 94, 130, 152, 470, 489

- Teuber, H. L., Mishkin, M. 8, 152
- Teuber, H. L., s. Semmes, J. 8, 151
- Thauer, R., Peters, G. 466, 467, 473, 480, 489
- Thiébaud, F., Isch, F., Collard, M., Concraux, C. 356
- Thomas, D. P., Whitney, R. J. 276, 280
- Thomas, E. L., s. Ackerman, U. 399, 402
- Thompson, A. B., s. Graybiel, A. 342, 352
- Thompson, Truet, B. 573
- Thornhill, R. A., s. Lowenstein, O. 496, 577
- Thornval, A. 270, 280
- Thorpe, W. H. 382, 387
- Thorton, C. L., s. Barrett, G. V. 119, 136
- Thulin, C. A., s. Gernandt, B. E. 263, 279, 452, 454, 460, 464, 486
- Tibbling, L. 6, 152
- Tibbling, L., s. Henriksson, N. G. 36, 145
- Timm, C. 284, 320
- Titov, Schwickhart 557
- Tokita, T. 355, 356, 434, 435, 449
- Tokita, T., Aoki, S., Yonekura, E., Shiraki, T., Kuroda, W., Takeuchi, T., Nakayama, S., Fujimoto, T., Aoki, M., Goto, T., Mizutani, T., Suganuma, Y. 355
- Tokita, T., s. Fukuda, T. 353, 354, 357, 373, 376, 377, 378, 385
- Tokita, T., s. Igarashi, M. 321, 352
- Tokumasu, K., s. Goto, K. 362, 367
- Torok, N. 221, 232, 365, 368, 374, 375, 387
- Torok, N., Guillemen, V., Barnothy, I. M. 220, 232
- Torok, N., Kahn, A. 271, 280
- Torok, N., s. Johnson, D. D. 375, 386
- Totsuka, G., s. Suzuki, J. 374, 387
- Toyne, M. J., s. Wilson, M. E. 596, 620
- Travis, R. C. 356
- Travis, R. C., Dodge, R. 44, 77, 78, 152
- Trendelenburg, W. 479, 489
- Trevisan, C., s. Duensing, F. 484, 486
- Trincker, D. 15, 68, 69, 152, 424, 427, 429, 432, 449, 452, 454, 462
- Tschermak, A. 408, 411, 416, 433, 449
- Tschiassny, K. 377, 387
- Tsuiki, Y. 429, 449
- Tullio 426
- Tumarkin, I. A. 25, 153
- Turnipseed, G. T., s. Stockwell, C. W. 311, 320
- Tyč-Dumont, s. Horcholle-Bossavit 586
- Tyler, D. B., Bard, P. 389, 390, 391, 393, 404
- Uchytíl, B. 276, 280, 356
- Udo de Haes, H. 159, 160, 161, 182, 190
- Udo de Haes, H., Schöne, H. 92, 109, 153, 163, 175, 179, 182, 190, 294, 320
- Udo de Haes, H., s. Schöne, H. 72, 85, 100, 109, 125, 151, 160, 163, 164, 165, 175, 182, 190
- Uemura, T., Cohen, B. 203, 205, 221, 232, 475, 489
- Uemura, T., s. Cohen, B. 119, 125, 140
- Uffenorde, K. 484, 490
- Ulrich, H. 68, 69, 70, 75, 153, 291, 320
- Ungar, G. 482, 490
- Uno, R., s. Kitahara, M. 110, 146, 414, 447
- Unterberger, S. 226, 232, 272, 273, 280, 355, 490
- Updegraff, B. P., s. Collins, W. E. 370, 373, 384
- Vaeth, W., s. Schwartz, R. P. 360
- Vaglino, F. 354
- Vallenstein, E. S. 580
- Vanderwolf, C. H. 612, 620
- Vasil'yev, P. V., Volynkin, Yu., K. 254, 266
- Vazuka, F. A. 354
- Veits, C. 222, 232, 415, 427, 449
- Veits, C., s. Fischer, M. H. 418, 435, 445
- Vendrick, A. J. H., s. Groen, J. J. 19, 59, 62, 144, 283, 317, 415, 423, 446, 502, 508, 509, 510, 511, 512, 518, 575
- Vernon, J. A., McGill, T. E., Gulick, W. I., Candland, D. K. 359
- Vernon, M. D. 182, 190
- Versteegh, C., s. Kleyn, A. de 211, 231, 277, 279, 307, 318, 407, 410, 447
- Versteegh, L. 165, 190
- Vilstrup, G., Vilstrup, T. 69, 70, 153
- Vilstrup, T. 514, 515, 579
- Vilstrup, T., s. Vilstrup, G. 69, 70, 153
- Van der Vis, K. 432, 449
- Visser, S. L. 200, 201, 232
- Vliet, A. G. M. van, Waardenburg, P. J., Forsius, H., Eriksson, A. W. 211, 232
- Vogel, K. 484, 490
- Vogelsang, C. J. 380, 387
- Vogt, C., Vogt, O. 609, 620
- Vogt, O., s. Vogt, C. 609, 620
- Vogts 609
- Voigt, K., s. Dichgans, J. 117, 141
- Voldrich, L. 562, 579
- Volokhova, N. A., s. Arla-schenko, N. I. 353
- Volynkin, Yu., K., s. Vasil'yev, P. V. 254, 266
- Voogd, J. 434, 449
- Voots, R. J., s. Mилоjevic, B. 304, 319
- Vossius, G., s. Stark, L. 589, 620
- De Vries, Hl. 25, 33, 69, 70, 71, 72, 75, 141, 432, 433, 449
- De Vries, Hl., Schierbeek, P. 25, 141
- Waardenburg, P. J., s. Vliet, A. G. M. 211, 232
- Wada, H., s. Saito, I. 310, 320
- Wade, N. J. 72, 153
- Wade, N. J., Day, R. H. 72, 153
- Wade, N., s. Day, R. 72, 141, 174, 187
- Wagman, I. H. 232, 609, 620
- Waite, R., s. Graybiel, A. 103, 104, 143, 242, 244, 264
- Walberg, F., Bowsher, D., Brodal, A. 268, 274, 280
- Walberg, F., s. Brodal, A. 268, 278, 505, 574

- Waldecker, G., s. Kornhuber, H. H. 195, 231
- Wallach, H., s. Köhler, W. 162, 188
- Walsh, E. G. 8, 71, 73, 74, 77, 78, 79, 80, 82, 87, 153, 163, 190, 436, 449
- Walsh, F. B., s. Ford, F. R. 353
- Walther, C., s. Bechinger, D. 594, 615
- Walzl, E., Mountcastle, V. 7, 8, 153
- Wang, S. C., s. Borison, H. L. 399, 403
- Wapner, S., Werner, H., Marant, R. B. 23, 153
- Wapner, S., Witkin, H. A. 356
- Wapner, S., s. Bauermeister, M. 85, 136
- Wapner, S., s. McFarland, J. H. 89, 148
- Wapner, S., s. Werner, H. 94, 154, 163, 190, 241, 266
- Wapner, S., s. Witkin, H. A. 181, 190, 356
- Warren, B. H., s. Roman, A. J. 298, 320
- Watanabe, I. 354
- Watanabe, T., s. Fukuda, T. 376, 377, 385
- Watson, J. L., s. Milojevic, B. 273, 279, 354
- Weaver, R. S. 120, 153, 392, 404
- Weaver, R. S., s. Money, K. E. 319
- Weber, G., Steiner, F. A. 586, 620
- Wehner, H., s. Schaefer, K. P. 482, 488
- Weill, G. A., s. Babinski, J. 272, 278
- Weinstein, E. A., s. Bender, M. B. 214, 229
- Von Weizäcker, V. 416, 449
- Welch, K., Stuteville, P. 612, 620
- Wendt, G. R. 7, 66, 153, 362, 368, 374, 375, 376, 382, 388, 389, 390, 391, 404, 426, 449, 450
- Wendt, G. R., s. Alexander, S. J. 262, 263
- Werner, H., Wapner, S., Chandler, K. A. 94, 154, 163, 190, 241, 266
- Werner, H., s. Bauermeister, M. 85, 136
- Werner, H., s. McFarland, J. H. 89, 148
- Werner, H., s. Wapner, S. 23, 153
- Wernicke 585, 614
- Wersäll, J., s. Engström, H. 69, 141
- Wersäll, J., s. Flock, A. 519, 575
- Wersäll, R., s. Aschan, G. 29, 136, 429, 430, 443
- Wertheimer, M. 160, 190
- Westheimer, G. 590, 620
- Westheimer, G., Blair, S. M. 587, 599, 620
- White, H. E. 11, 154
- White, P. D., s. White, W. J. 359
- White, S. C., s. Minners, H. A. 358
- White, W. J., Nyberg, J. W., White, P. D., Grimes, R. H., Finney, L. M. 359
- Whiteside, T. C. D., s. Benson, A. J. 262, 263, 299, 300, 316, 550, 573
- Whiteside, T. C. D., s. Niven, J. I. 262, 265
- Whiteside, T. D. M., Graybiel, A., Niven, J. I. 35, 154, 256, 266
- Whiteside, W. H., s. Graybiel, A. 575
- Whitney, E. 359
- Whitney, R. J., s. Thomas, D. P. 276, 280
- Wiesel, T. N., s. Hubel, D. H. 172, 188
- Wigand, M. E., Struppler, A. 276, 280
- Wiggers, C. J. 570, 580
- Wilcox, J. G., s. Miller, E. F. II. 235, 265
- Williams, D. J. 437, 438, 450
- Wilson, M. E., Toyne, M. J. 596, 620
- Wilson, T. G., Pike, F. H. 468, 490
- Winestein, S., s. Semmes, J. 8, 151
- Winget, C. M., Smith, A. H. 370, 388
- Winget, C. M., Smith, A. H., Kelly, C. F. 373, 388
- Winkler, C. 468, 490
- Winston, J. 482, 490
- Wirth, G. 354
- Wist, E., s. Brandt, Th. 119, 125, 138
- Wist, E. R., s. Schmidt, C. L. 607, 620
- Witkin, H. A. 109, 110, 154, 160, 162, 165, 182, 190, 241, 266
- Witkin, H. A., Asch, S. E. 160, 162, 182, 190
- Witkin, H. A., Lewis, H. B., Hertzman, M., Machover, K., Meissner, P. B., Wapner, S. 181, 190
- Witkin, H. A., Wapner, S. 356
- Witkin, H. A., s. Asch, S. E. 160, 162, 185
- Witkin, H. A., s. Wapner, S. 356
- De Wit, G. 353, 390, 403, 406, 408, 411, 430, 450
- Wittmaack, K., s. Bárány, R. 270, 271, 278
- Wodak, E. 268, 272, 275, 280, 418, 450
- Wodak, E., Fischer, M. H. 270, 280
- Wodak, E., s. Fischer, M. H. 269, 270, 271, 272, 274, 276, 278, 429, 433, 445
- Woellner, R. C., Graybiel, A. 159, 190, 239, 266, 525, 580
- Wojatschek, W. 405, 411, 450
- Wolfe, J. W. 115, 126, 154, 364, 368
- Wolfe, J. W., s. Brown, J. H. 60, 138
- Wolfe, J. W., s. Llinás, R. 599, 608, 618
- Wood, C. D. 402, 404
- Wood, C. D., s. Fregly, A. R. 322, 351
- Wood, C. D., s. Graybiel, A. 257, 264, 402, 403
- Wood, J. D., s. Money, K. E. 126, 149
- Wood, R. W. 160, 190
- Woolsey, C. N., s. Bard, P. 607, 615
- Woolsey, C., s. Hampson, J. 598, 617
- Worchel, P., Dallenbach, K. M. 354
- Worchel, P., s. Bittermann, M. E. 162, 186

- Worden, F. G., s. Schmitt, F. O. 602, 606, 607, 611, 613
 Wrenn, L. G. 573
 Wright, G., s. Barber, H. O. 201, 206, 229, 365, 366
 Wright, J. H., s. Gescheider, G. A. 85, 142
 Wrigley, W., s. Draper, C. S. 496, 576
 Wüst, H. 223, 232
 Wulfften Palthe, P. M. van 406, 411, 425, 450
 Wurtz, R. H., Goldberg, M. E. 217, 232, 604, 620
- Yacorzynski, G., s. Halstead, W. 373, 386
 Yagura, S., s. Saito, I. 310, 320
 Yamamoto, M., s. Ito, M. 586, 617
 Yao, T. Li, s. Young, L. R. 502, 524, 525, 530, 539, 546, 580
 Yemel'yanov, M. D., s. Galle, R. R. 359
 Yonekura, E., s. Tokita, T. 355
- York, E., Brown, K. R., Goldfien, A. 359
 Yoshida, M., s. Ito, M. 587, 605, 617
 Young, F. A., s. Crampton, G. H. 119, 140
 Young, H. H. 160, 190
 Young, H. H., Meiri, J. L. 165, 190
 Young, L. R. 109, 154, 282, 285, 320, 530, 580
 Young, L., Meiry, J. 71, 74, 154, 530, 580
 Young, L. R., Meiry, J. L., Yao, T. Li. 502, 524, 525, 530, 539, 546, 580
 Young, L., Oman, C. M. 42, 56, 64, 154, 296, 306, 320, 509, 515, 516, 580
 Young, L. R., Stark, L. 587, 594, 620
 Young, L., s. Dichgans, J. 119, 125, 141
 Young, L. R., s. Stark, L. 589, 620
- Youngermann, W. M. 202, 232
 Yuganov, Ye. M. 298, 306, 320, 393, 402, 404
 Yuganov, E. M., Gorshikov, A. L., Kasyian, I. I., Bryanov, I. I., Kolosov, I. A., Kopanev, V. I., Lebeden, V. I., Popov, N. I., Solodovnik, F. A. 554, 556, 580
 Yugatov, s. Feoktistov 556
- Zarriello, J. J., s. Graybiel, A. 131, 143, 353, 392, 403, 567, 575
 Zilstorff, K., s. Osterhammel, P. 375, 376, 377, 387
 Zilstorff-Pedersen, K., Peitersen, E., 273, 274, 280, 355
 Zilstorff-Pedersen, K., s. Peitersen, E. 272, 274, 275, 276, 280, 355
 Zippel, H. P., s. Domagk, G. F. 482, 485
 Ziter, F. A., s. Bray, P. F. 213, 229

Subject Index

- abducens motoneurons 458
- , nystagmus rhythms 586
- paralysis 8
- ability to indicate vertical 91
- ablation experiments and compensation 475
- abnormal eye motions 239
- oculomotor syndrom 207
- abnormally fatigable patients, vestibular responses of 361
- absence of gravity 252, 254
- of position sense 88
- of vision during rotation 116
- Abweichreaktion, caloric stimulation 270, 271
- acapnia and motion sickness 400
- accelerated free fall 555
- acceleration, angular, see angular acceleration
- , centrifugal 417
- , centripetal 79, 82, 107, 282, 286, 287, 299, 302, 498, 542
- , Coriolis- 120, 283, 298, 315, 499
- , gravitational, see gravitational acceleration
- , high-magnitude linear 107
- , horizontal 255
- , — linear, changing 105, 106
- , — —, discrimination from tilt 105
- , illusory 543, 548, 557, 561
- , linear, see linear acceleration
- , multiplanar 392, 393
- , rotatory 415
- , spurious 432
- , sustained 7, 9, 107, 298, 304
- , tangential 282, 283, 286
- , time varying linear 308, 312
- , transient 540
- , measurement of 499, 514
- , perception of 554
- , otolith response to 533
- , rotating linear vector of 546, 548
- , sinusoidal input of 523
- -dependent otolith signals 563
- -step stimulus 20, 24, 523
- receptors 282
- registraphy 277, 359
- vectors, angular 12, 15
- —, linear 12, 286, 289, 290, 546, 548
- accelerators, horizontal, experiments with 106
- acceleratory stimuli, nomenclature of 10
- —, resolution of 13
- accelerometer 359
- , angular 23, 496, 498, 503, 515, 520
- , conventional 563
- , differentiating 520, 522, 563
- , integrating 503, 520, 530
- , linear 496, 498, 520, 530
- accommodation of nystagmus and turning sensation 134
- accuracy of mean judgments 84
- acetylcholine and motion sickness 401, 410
- Achilles tendon reflex 276
- achromatopsia, nystagmus in 211
- acoustic neuroma 196, 222, 228, 229, 324, 333, 335
- trauma 336
- actions, shifting focus of 614
- activity, vestibular cortical 8
- acuity, visual, see visual acuity
- acute alcohol ataxia and intactness of vestibular apparatus 350
- adaptation 173, 369
- , heterolateral 425
- , homolateral 425
- to angular acceleration 58ff
- in the caloric response 306
- of canal neurons 510, 552
- of canal signals 294, 508, 509, 512
- to constant rotation 339
- for constant velocity 515
- of control of body movements 510
- effects 42, 45, 50
- , endolymph flow/cupula 515
- model 64
- of nystagmus 134, 508, 510
- to sea-sickness 406, 408
- , Steinhausen model 506, 508
- to tilt 72, 90
- time constant 296, 297, 315
- of turning sensation 134
- in vestibular organs 369, 423, 424, 567
- adaptive coupling, semicircular canal 296
- ADH during motion sickness 401
- adiadochokinesis 605
- adjustment 464

- adjustment of nystagmus and turning sensation 134
 adrenaline and motion sickness 397, 410
 —, recovery of nystagmus by 362
 adverse seizures 215
 A-effect, see Aubert effect
 aerobic pilots, vestibular habituation 376
 aerospace flight and motion sickness 398, 400, 401, 402
 — navigation 494
 — travel 392
 aetiology of motion sickness 390
 afferent neurons, primary, stimulation by linear acceleration 284
 afferents, eye muscle- 598
 — from limb joints 584
 —, macular 290
 — from mechanoreceptors 605
 —, neck- 584
 —, somato-sensory 479
 —, spinoreticular 481
 African parrot, nystagmus 370
 aftereffect of alcohol on nystagmus 202
 —, optokinetic 118, 119
 —, rotation - 92
 afterimages, visual 106
 afternystagmus, optokinetic 125, 225, 226, 371
 after-reaction, primary 61
 after-sensations, phasic secondary 433
 —, primary 29
 —, rhythmic 419
 — of rotation 418, 419
 — cupulogram 429
 agoraphobia and vertigo 438
 agravitoinertial forces 236, 237
 aircrew, see astronauts
 airplane autopilot, determination of the vertical 538
 akinesia 601, 608, 609
 akinetic mutism 613
 Åland eye disease 211
 alcohol and compensation of vestibular lesions 482
 —, effect on otolith organ function 258
 — and vertigo 437, 438
 —, effect on visual acuity 130
 — aftereffects on nystagmus 202
 — -induced ataxia 346, 350
 — ingestion and stepping test 275
 — intoxication 130, 205, 425
 — nystagmus 307, 365
 alerting stimulus 374
 alertness control 362
 Alexander's Law 308
 alkali reserve during motion sickness 401
 Ames MCRP devices 117
 amphetamine, influence on compensatory processes 482
 — and motion sickness 402
 — and nystagmus 364, 365
 ampullar messages 163
 — receptors 282, 312
 — —, first- and second order neurons of 287
 — —, gravitational acceleration as adequate stimulus 291
 — —, stimulation by linear acceleration 283
 — —, thermal stimulation 306
 — responses, suppression of 302
 anaemia, cerebral 398
 — and vertigo 438
 anaesthesia, effect on habituation of rotation-induced head nystagmus 361
 — and vestibular sensation 425
 angle, phase-, see phase angle
 — of tilt 242
 angular acceleration 12, 15, 27, 282, 362, 515
 — —, constant 24
 — —, multi-planar, and motion sickness 392
 — —, pendular 223
 — —, simple, subjective reactions to 21
 — —, unidirectional 223
 — —, adaptation to 58
 — —, axis of 16
 — — and cupula deflection 21, 24, 26
 — —, interaction with linear acceleration 281, 284, 312
 — —, magnitude of 16
 — —, modification of the response to - by linear acceleration 281ff
 — —, pendular eye deviations during 211, 212
 — — and nystagmus 62, 220, 291, 302, 377
 — —, thresholds of perception 23ff
 — — and vestibular responses 223
 — — vector 116
 — accelerometer 23, 496, 498, 503, 515, 520
 — displacement estimation 44, 49, 51
 — distortion phenomenon 162
 — impulse 20, 121, 122
 — momentum, changes in 120, 121
 — motion and motion sickness 391
 — oscillation in the yaw 312, 313
 — —, whole-body 127
 — position relative to gravity 18
 — sensors 500, 501
 — velocity, canal-generated 122, 515
 — —, constant 113
 — —, subjective 44, 47, 421, 422
 — —, —, direct measures of 43

- angular velocity, subjective, and information theory 56
 — —, —, magnitude estimation of 39 ff
 — —, —, and nystagmus 66
 — — impulses 20
 — — information, otolith system 105, 112
 — — transducers 20
 — —, canal responses to 502
 — — and cupula deflection 21, 421
 — —, perception of 13, 18, 56, 125
 — —, sensation of 424
 animal hypnosis 362
 animals, foveate and nonfoveate, nystagmus in 594
 —, labyrinthine-defective 501
 —, compensation of vestibular lesions 463 ff
 — with inoperative canals 543 ff
 —, motion sickness in 405, 427
 —, spontaneous nystagmus in 211
 —, vestibular habituation in 370
 anisometropia 207
 anomaly of foveal vision 208
 anticomensatory reactions 543, 544
 antidiuresis and motion sickness 397, 401
 antigravity muscles 268
 — stretch reflex 585
 antihistamines and motion sickness 402, 410, 570
 anxiety 179
 apathy 614
 aphasia, frontal 614
 —, Broca's 614
 —, Wernicke's 614
 apparent angle of tilt 242
 — displacement of visual target 380
 — horizontal 162, 241, 558
 — motion, reversal in 68
 — — of the environment 197, 242, 380, 593
 — tilt 119
 — vertical 86, 160, 162, 169, 170, 174, 176, 178, 179, 180, 181, 182, 241
 — — as a function of lateral body tilt 161, 242
 — — in or out of water 248, 249
 apraxia 599, 600
 —, gaze - 217
 —, oculomotor 218
 appropriate stimulus for semicircular canals 415
 — — of vestibular organ 414
 arachnoiditis and vertigo 440
 arc of uncertainty 84, 85, 86, 88, 89
 — — —, see also U deg
 archicerebellum and motion sickness 607 ff
 —, visual input to 604
 archicerebellum, visual control of the vestibular-ocular reflex arc 590
 area 8 (frontal eye field) 611, 612
 —, pretectal 588
 —, Rolandic 609, 610
 —, striate, destruction of 218
 —, vestibular projection - 8
 areas, cortical, and vestibular sensations 7
 —, sensory association - 599
 arm tonus reaction 227, 270
 Armtonusreaktion 227, 270
 arousal 362
 — effects 66
 — nystagmus 261, 363
 —, vestibular responses to 361 ff
 arteriosclerosis and vertigo 438, 443
 arteriosclerotic lesions 205
 artery, vertebral 196
 —, vertebro-basilar 207
 association cortex 599
 astronauts 104, 244, 254, 261, 290, 298, 324, 402, 555, 556, 557
 —, see also pilots
 —, vestibular sensations 425
 asymmetry index 235
 — in vestibular influences on oculomotor nuclei 455
 ataxia, alcohol-induced 346, 350
 —, cerebellar 277
 —, compensated vestibular 328
 —, induced vestibular 338, 350
 —, residual 345
 —, rotation-induced 344
 —, spontaneous vestibular 324, 336, 350
 —, vestibular, measurement in man 321 ff
 — of visually guided hand movements 218
 —, effect of age and sex on 324, 325
 — in normals 324
 — test battery 322
 — test methods, bibliography of 352
 — tests in labyrinthine-defective subjects 324, 326, 327, 328, 329, 330, 331, 333, 335, 336, 344, 345, 346, 347
 ataxiagraphic methods 355
 ataxiometric methods 355
 athetosis 608
 atrophy, cerebellar 226
 —, cerebelloctical 583, 596, 598, 603, 604
 —, Friedreich's 598
 —, transneuronal, of oculomotor neurons 598
 atropine and motion sickness 410
 attacks of vertigo 195 ff
 attention to vestibular sensations 67
 —, visual 612
 — habituation 135, 136
 — shifts and linear displacement estimation 106

- Aubert effect 86, 94, 96, 161, 241
 Aubert-Fleischl paradox 52
 audiogyral illusion 432
 — phenomena 417
 audiometry 234
 autistic children, nystagmus in 365
 autocompensation 166, 172, 173
 —, feed-back - 176
 —, visual 169
 autogyral effect of body and visual reference
 28, 36, 117, 118
 autokinesis, rotatory 242
 — for a point source of light 242
 automatic holding 194
 autonomic effects of motion sickness 392
 — nervous system and motion sickness 399
 avitaminosis and vertigo 438
 awareness, cognitive, of vestibular information 135
 axis, primary 169, 170
 —, secondary 169, 170
 — of angular acceleration 16
- Babinski sign** 218
 balance, poor, during swimming 91
 — reactions 277
 — tests 90
 ballism 608
 barbecue rotation experiments 548
 barbiturate anesthesia 584
 barbiturates, intoxication by 205, 590
 Bárány test 423, 427
 basal ganglia 614
 — —, diseases of 601
 — —, inputs from motor cortex 602
 — —, lesions in 608
 — — as ramp generator 608
 basic components of an inertial system 500
 — principles of inertial navigation 498
 Bechterew compensation 463, 472, 473, 474,
 475, 476
 — compensatory nystagmus 456, 457, 483,
 484
 bending 530
 benign paroxysmal positional nystagmus
 437, 439, 441
 Bereitschaftspotential 600
 bicomponent theory 164
 bilateral labyrinthine defective persons
 (BL-Ds) 324, 326, 327, 328, 329, 330, 331,
 336, 338, 344, 345, 346, 347
 — loss of labyrinth function 164
 — loss of vestibular function 332
 binocular coordination 215
 Biperiden 215
 birds, compensation of vestibular lesions
 463, 465, 472, 477, 479
- birds, nystagmus 219, 370, 371, 372, 373,
 378
 —, static function of otolith organs 165
 birth trauma 202
 blepharospasm 440
 blind, cortically 218
 — spots of the labyrinths 417
 — of the otolith organs 80, 242, 436
 blindfolded observers 90
 blindfold walking 272
 blindness and eye position 587
 —, involuntary spontaneous eye movements
 in 210
 — and motion sickness 607
 — and vestibular sensation 426
 blood acetylcholine and motion sickness 401
 — flow and motion sickness 394, 395
 — in the perilymph, nystagmus 206
 — pressure and motion sickness 393, 395
 — — and vertigo 196, 438
 — -supply, vertebro-basilar 228
 blurred vision 195
 Bode plot of canal responses 505
 body, see also whole-body
 —, displacement of 169
 —, force field on 87
 —, orientation relative to 85
 — angle motions, frequency spectra of 251
 — -axis dependence 110
 — control and vestibular system 500
 — inclination 181
 — movements, illusions of 563
 — —, path of 111
 — orientation 156
 — —, unexpected perceived changes in
 125
 — position 170
 — —, stabilization of 194, 583
 — rotation, perception of 118
 — reference versus visual reference 106
 — surface, pressure on 163
 — -sway motion 253
 — tilt 182, 242
 — —, estimate of 83
 — —, influence on orthogonality of space
 perception 162
 — tonus, asymmetric 163
 brainstem 588, 601
 — damage and spontaneous nystagmus 202
 — disease, square-wave jerks 212
 —, ischemia of 204
 —, lesions of 196, 202, 216, 226
 brain tumors and vertigo 440
 Broca's aphasia 614
 —, field 614
 bulbar lesions 484
 — palsy, progressive 228

- buoyancy cues 91
 buttocks, anesthetizing of 87
 butyryperazine 481
- caffeine 481, 482
- calcium, content during motion sickness 401
- caloric habituation 372, 373
 — irrigation of the ear 115
 — nystagmus, see nystagmus, caloric
 — responses 113, 229
 — —, acoustic neuroma 222, 333, 335
 — —, adaptive mechanisms of 306
 — —, evaluation of 220, 221
 — —, influence of visual fixation 222
 — —, misinterpretations 221
 — — and recovery nystagmus 204
 — stimulation 220, 269, 270, 272, 276, 362, 381, 418, 434, 435
 — stimuli, measurement of vestibulo-spinal responses to 274
 — test, head- and body position 115, 220
 — —, hemispheric lesions 222
 — — in labyrinthine-defective subjects 331, 335, 483
 — —, methods of 222, 226, 303
- canal, see also semicircular canal, canals
 —, cross-section of 507
 — afferents, positional responses 284, 285
 — —, primary, activity of 287
 — -dependent cells 549
 — — responses, suppression of 123
 — — units, velocity information by 112
 — function, subjective and objective indicators of 295
 — -generated angular velocity 122
 — inputs, convergence of 287
 — model, see Steinhausen model
 — neurons, primary 509, 510, 552
 — -otolith interactions 121, 256, 259
 — receptors 251
 — response to angular velocity 502
 — — to gravireceptor stimulation 295
 — — to gravitational acceleration 292
 — — after habituation 132
 — — during head tilts 132
 — —, mathematical model of 296
 — —, postrotational 92
 — —, suppression of 296
 — — to weightlessness 298
 — sickness 262
 — system, natural frequency of 33
 — units, activity of 287
 — —, responses to linear acceleration vector 289
- canals, horizontal, vestibular neurons 454
 —, inoperative, in animals 543
 —, lateral 121
- canals, lateral, adaptation of the signal from 294
 —, —, central suppression of the signals from 294
 —, vertical, pathology of 432
- carbon dioxide, content during motion sickness 401
- cardiac action and motion sickness 393
- cardiazole 482
- carotid obstruction 196
- cat, compensation of vestibular lesions 470, 472, 474, 476, 478
 —, with defective canals 544
 —, nystagmus in 211, 371, 372, 374
 —, response to linear acceleration 548
- catatonic patients, vestibular responses 361
- catecholamines, content during motion sickness 401
- cells at the apex of the crista 515, 553
 —, canal-dependent 549
 —, Ewaldian 286, 288
 —, granular 603, 605
 —, non-Ewaldian 288
 —, otolithic, see otolithic cells
 —, Purkinje- 587, 603, 605, 608
 —, rotation-dependent 549, 567
- central compensation of vestibular function 460
 — factors, habituation 381
 — nervous system, response to linear acceleration 548
 — — — diseases and vertigo 438
- centrifugal acceleration, sensation of 417
 — forces 165
- centrifugation under water 235
- centrifuge 81, 83, 96, 97, 107, 110, 111, 242, 259, 299, 392, 416, 435, 550
 —, counterrotating 111, 549
 — stimulus 79
 — studies 95, 96, 235, 239
- centripetal acceleration 79, 82, 107, 282, 286, 287, 299, 302, 498, 542
- cerebellar ataxia 277
 — atrophy 226
 — cortex 588
 — —, eye muscle afferent projection to 598
 — —, peripheral mossy afferents to 605
 — —, removing of 583, 587
 — —, saccadic function of 602
 — —, step generator 599
 — disease, square-wave jerks 212
 — encephalopathy, paraneoplastic 213
 — extirpation in pigeons 477
 — inhibition 453
 — nodulus, lesions of 205
 — nuclei 603

- cerebellar nuclei, analogy in function with vestibular nuclei 607
 — — and eye movements 586, 587, 588
 — —, function of 605ff
 — —, intoxication of 210
 — —, lesions of, and nystagmus 199, 217
 — — step and holding functions 604
 — — tumor and saccades 596
 — — and vertigo 440, 441
 cerebellectomy 584, 586, 589
 — in guinea-pigs 478
 — and nystagmus 599
 — and saccades 599
 cerebellocortical atrophy 583, 596, 598, 603, 604
 — lesions 589, 597, 605
 cerebello-nuclear lesions 605
 cerebellopontile arachnoiditis 440
 cerebello-pontine angle, acoustic neuroma 228
 cerebellum 115, 116, 217, 475, 582, 588, 614
 —, compensation of vestibular function 460
 —, diseases of basic ganglia 601
 — in emotional processes 126
 —, influence on compensation of vestibular lesions 477ff
 —, inputs from motor cortex 602
 —, lesions of 226, 228
 —, nuclear and cortical functions in 587
 — and saccades 596, 598
 —, second vestibular integration 589
 —, vestibular tracts in 390
 — and visual inhibition of vestibular nystagmus 116
 cerebral anaemia during aerospace flight 398
 — concussion 204
 — contusion 204
 — cortex, influence on compensation of vestibular lesions 475ff
 — —, influence on postural functions 475, 477, 588
 — —, influence on vestibular functions 475, 603
 — —, influence on visual functions 475
 — —, visual regulation of eye position 587
 — deficiency, compensation of 475
 — hemispheres, vascular lesions in 484
 — lesions, space coordinates 162
 — potentials preceding voluntary movements 600, 601
 cerebrovascular accidents and vertigo 442
 — insufficiency 195, 336
 cerebrum, removal of, and compensation 475
 cervical nystagmus 436
 — root lesions 206, 584
 — vertigo 436
 cervico-ocular reflex 223
 change of gravity, response to 527
 — -in-orientation information, otolith system 105
 — -in-position 90, 92
 — — —, memory of 90
 — — — information 18, 90, 112
 — — — units 72
 changes in angular momentum 120
 — in direction 111
 — in the distal environment 169
 changing horizontal linear acceleration 105, 106, 107
 "channel capacity" for perception of angular velocity 56, 57
 chemical aspects of motion sickness 401
 chimpanzee, motion sickness 427
 —, spontaneous nystagmus 211
 chlorpromazine 364, 481
 chorea 608
 cinnarizine 258, 364, 410
 claustrophobia and vertigo 438
 climbing fiber action, parametric gain adjustment via - 604
 — sensation 123, 125
 clinging 179
 clinical history of vertigo 195, 197
 clonic upward eye movements 215
 clopenthixol 481
 coarse saccade 596
 cochlear symptoms 195
 Cogan's syndrome and vertigo 440
 cognitive awareness of vestibular information 135
 color blindness 211
 collicular lesions 217
 colliculus, superior 217, 596, 612
 commissural fibers, cutting of 457
 — inhibition, compensation of 459
 — pathways 290
 commissure, posterior 217
 compensation 156
 —, Bechterew - 463, 472, 473, 474, 475, 476
 —, external and internal 159, 174
 —, feed-back - 173, 176
 —, feed-forward - 173, 174
 —, latent 472
 —, optical 177
 —, Ruttin - 472
 —, vestibular 177, 451, 460
 — of commissural inhibition 459
 — of labyrinthectomy 463ff
 — of vestibular lesions 463ff
 —, time-course of 465
 — principle 157, 158, 169
 compensatory errors 160
 — eye movements 225, 234

- compensatory function 158, 159
 — nystagmus 310
 — —, Bechterew's 456, 457, 463
 — oculogyral illusion 380, 381
 — righting reactions 277, 543
 — variable 173, 177
 — vestibular responses 295
 compression of the vertebral artery 196
 concept of threshold 35
 concomitant squint 207, 208
 conditioning of a single neuron 567
 conflict theory 568
 congenital nystagmus 198, 202, 208, 209,
 210, 211, 219, 228, 426
 conjugate deviation 454
 consciousness 425
 — in aerospace flight 398
 conscious perception 418
 consistent position signaling 112
 constancy, directional 157
 —, motion 172
 —, vertical 157, 166, 172
 — of space perception 156
 — of visual space 197
 — problem 157
 constant, Mulder's 30
 — angular acceleration 24
 — angular velocity 113
 — speed off-vertical rotation 113
 — stimulus of gravity 259f
 — velocity rotation 111, 288
 contour detection 172
 conventional accelerometers 563
 convergence of canal and gravireceptor in-
 puts 287
 — retractory nystagmus 217
 — of somatic and vestibular afferents to
 motor cortex 610
 convergent detection 177, 178
 convulsive disorders 195
 coordinate systems, perceptual 164
 Coriolis acceleration 120, 283, 298, 315, 499
 — cross-coupled reaction, vestibular 133
 — — stimuli, vestibular 124, 125
 — — —, perceptual phenomena of 123
 — effect 119, 120, 125, 131, 553, 607
 — forces 423
 — — and motion sickness 408
 — illusion 553ff
 — nystagmus test 339
 — stimulation 377, 381, 382, 527, 563
 — torque stimulus 133
 — vestibular reaction 120
 corneoretinal potential, drug effect on 364
 corpus callosum, section of 216
 correction 156
 — principle 177, 180, 181, 182
 correction saccades 594, 596
 cortex, cerebellar, see cerebellar cortex
 —, cerebral, see cerebral cortex
 —, cingulate 614
 —, frontal 611, 614
 —, infero-temporal 611
 —, motor - 217, 600, 602, 609, 610
 —, orbital 126, 613
 —, sensorimotor 609
 —, striate 611
 —, temporo-basal 611
 —, nystagmogenic zones of 475
 cortical areas and vestibular sensations 7
 — association areas 599
 — evoked potentials 9
 — lesions and gaze paralysis 216, 217
 — stimulation, influence on nystagmus 477
 — vestibular representation 7
 cortically blind 218
 cortico-cortical association fibers 612
 — connections from the striate cortex 611
 — reflex arc 600
 corticofugal fibers, lesion of 587
 corticosteroids, content during motion sick-
 ness 401
 cosmonauts, see astronauts
 cosmos sickness 402
 counterrolling, dynamic 68, 525, 526, 527,
 528, 546
 —, ocular 68, 94, 103, 226, 234, 235, 239,
 252, 259, 517, 525, 526, 554, 563
 —, static 525, 526
 counterrotation 286
 — on a centrifuge 111, 549
 countertorsion, ocular 159, 174, 178
 cranial nerve, eighth, and motion sickness
 390
 crista ampullaris 14
 —, type I cells 515, 553
 —, type II cells 515
 cristae, adequate stimulation of 284
 —, response to gravity 284
 —, stimulation by linear acceleration 284
 cross-coupling effect 119, 120, 121, 125, 131
 — stimulation of the canals 554
 cues, buoyancy - 91
 —, kinesthetic 527
 —, nonvisual, and visually perceived direc-
 tion of space 241
 —, postural direction 163ff
 —, somesthetic, eliminated 545
 —, somatosensory 88, 90, 91, 93, 94, 113
 —, vestibular and nonvestibular, reduced 90
 cue system, postural 179
 cupula 14
 —, density of 285, 552, 553
 —, elasticity of 506, 508

- cupula, hysteresis in 419
 —, measurement of acceleration 514
 —, measurement of velocity 514
 —, model of 289
 —, motion of 513
 —, specific gravity of 285
 —, time constant of 285
 — deflection and angular acceleration 21, 24, 26, 27, 29
 — — and angular velocity 21
 — — by centripetal acceleration 286
 — — by gravity 294
 — — by linear acceleration 284, 285, 286, 287
 — —, peak - 38
 — — and sustained nystagmus 301
 — —, threshold methods and working equations 37
 — displacement 47, 502, 503
 — dynamics 25
 — 's elastic restoring force 29
 — -endolymph loop 19
 — — system 31, 38, 415
 — recovery, working equations 38
 — return 29
 — sensory cells, asymmetrical response 514
 cupular stimulus, quantitative estimation 427
 cupulogram 28, 29, 30, 31, 35, 408, 409, 420, 422, 433
 — and adaptation 429
 —, after-sensation - 429
 —, nystagmus - 421, 430
 —, sensation - 421, 422, 423, 428
 —, working equations 38
 cupulometry 419, 420, 428, 429, 434
 —, clinical 415
 —, sinusoidal 66
 — after-reactions 433
 cutting of commissural fibers 457
 cyclic modulation 111, 113
 cyclizine, and motion sickness 402
- damped spring system 19, 33, 38
 dancers, nystagmus in 369, 376, 377
 —, vestibular sensations in 425
 data processing 500
 deaf children 436
 — man 90, 95
 — mutes 7
 — — and motion sickness 390, 405
 deafferented type I vestibular neurons 459
 deafness, hereditary 436
 —, long-standing 336
 decay of the nystagmus 62, 111, 123
 deceleration from off-vertical rotation 113
 —, nystagmus after 378, 548
- deceleration, sensations during 22
 decerebellation and vestibular sensation 426
 decerebration and vestibular sensation 426
 deep reflexes to vestibular stimuli 276
 — sea divers 324
 — sensibility 88
 deflection, utriculofugal 15
 —, utriculopetal 15
 — of the cupula, see cupula-deflection
 degeneration of synaptic endings 459
 dehydrogenase, content during motion sickness 401
 Deiters' nucleus 268
 delay time, cerebellar cortex fibers 604
 — — in the initial tilt position 85
 demyelination, dentate nuclei 213
 dentate nuclei, demyelination 213
 — nucleus and spontaneous eye movements 213
 destruction of one striate area 218
 — of the vestibular nerve 203
 detection of angular acceleration by the canals 509
 —, convergent 177, 178
 —, displacement - 34
 —, rotation - 34
 determination, see also perception, sensation
 — of displacement 538ff
 — of linear velocity 538ff
 — of velocity and position 497ff
 — of the vertical 534ff
 deviations from ideal veridicality 161
 diabetes and vestibular sensation 432, 438
 diencephalic lesions 214
 — tumor 203, 214
 difference limens 34
 differentiating accelerometer 520, 522, 563
 diphenylhydantoin, intoxication by 205
 diplopia and vertigo 438
 direction, perverted, of caloric nystagmus 221
 —, visually perceived, in space 238, 241
 —, changes in 111
 —, memory of 104
 — of linear acceleration 81
 — of space, nonvisually perceived 249
 — of spontaneous nystagmus 202
 — of the vertical, sensed 542
 — -reversing nystagmus 113
 — cues, kinesthetic 163
 — —, optical 163, 166, 178
 — —, postural 163ff
 — —, tactile 163
 — —, vestibular 163, 164
 — — for horizontality 169
 — — for verticality 169

- directional asymmetry 290
 — constancy 157
 — difference in dynamic vision 129
 — — in nystagmus 127, 129
 — induction 160, 178, 182
 — predominance of nystagmus 452
 — sensitivity 290
 disequilibrium, postural 239, 257
 disinhibition of primitive drives 613
 disk protrusion 206
 disorders, convulsive 195
 —, psychogenic 336
 disorientation due to head movements 556
 displacement, angular 44, 49, 51
 —, linear 106
 —, perceived 106
 —, tangential 70
 —, target - 106
 —, true 106
 — of the body 169
 —, determination of 538ff
 — of the otolith membrane 17
 — of otoliths 69, 71
 — detection 34
 — measures, subjective 48
 distal stimulus 158
 distortion, angular 162
 distribution of pressure on the body surface 163
 disturbance of eye movements 215
 — of optokinetic nystagmus 218
 disturbances, reflex vestibular 257, 262
 divers, deep-sea - 324
 diving, sensation of 123
 dizziness 119, 369, 438, 443
 —, episodic 330
 dog, compensation of vestibular lesions 471, 472, 479
 —, spontaneous nystagmus 211
 dorsal light reactions 178, 180
 — roots 479, 584
 dorsomedial nucleus, afferents from hypothalamus and limbic system 612
 double vision 195
 dramamine and motion sickness 410
 drive to act 612, 613
 drop-attacks 195
 drowsiness 212
 drug intoxication 215
 drugs and compensation of vestibular lesions 481
 —, effect on nystagmus 364, 365
 —, effect on otolith organ function 258
 —, suppression of motion sickness by 401, 402, 410
 dynabalometer 356
 dynamic counterrolling 68, 525, 526, 527, 528, 546
 — otolith stimuli 68
 — responses of otolithic cells 519, 520, 525, 532, 533
 dynamics of the otoliths 69, 71
 dysacusis and caloric stimulation 434
 dysfunction, labyrinthine 87
 dysmetria 609
 — of saccadic eye movement 596, 598, 603
 — of step movements 605
 dysmorphosia 162
 dystrophy, ocular muscle - 215
E 600 482
 ear, caloric irrigation of - 115
 —, chronic processes in the -, and vertigo 442
 —, inner, diseases of 202, 275
 —, —, vascular lesion 195
 earth, reflex actions relative to 18
 — reference, otolith-detected 115
 — —, vision-detected 115
 eccentric gaze positions 589
 — rotation 299
 E-effect, see Müller-effect
 EEG, angular accelerations and 362
 — and nystagmus 362
 efferent vestibular system 285
 egocentric orientation ability 91
 — positioning of the line relative to the body 95
 Einstein's equivalence principle 103, 104
 elasmobranchs, canal responses 502, 508, 509, 510, 552
 —, otolith responses 519
 —, vestibular receptors 284
 elasticity of the cupula 506, 508
 electric stimulation and vertigo 438
 electrobasometer, force plates - 359
 electronystagmography 200
 electrooculogram 199, 200
 elevator, motion sickness 391
 — illusion 262
 ellipse of uncertainty, head-up position 89
 emesis 396, 401
 emotional processes, cerebellum in 126
 encephalitis, square-wave jerks 212
 — and vertigo 439, 442
 —, viral, and ocular myoclonus 213
 encephalopathy, cerebellar 213
 endolymph 14
 —, density of 285, 552, 553
 —, protein content of 562
 —, redistribution of 288
 —, specific gravity of 16, 303

- endolymph, viscosity of 507, 562
 — displacement 502, 552
 — flow, utriculopetal and utriculofugal 453
 — pressure, pathology 562
 endolymphatic cavity, hydrops in 561
 — fluids 562
 — systems, model of canal with 289
 endolymphatic sac 561, 562
 eosinophils, content during motion sickness 401
 ephedrin and motion sickness 402
 epilepsy, petit mal - 215
 —, temporal lobe - 196
 epileptic nystagmus 215
 — vertigo 196, 439, 441
 equilibrium, labile 168
 —, postural 234, 250, 261, 333, 346
 —, —, bibliography of 352
 —, function of lagena 559
 — in lunar walk 254
 —, maintenance of 250
 —, organs of 495
 — responses, postural 156
 equivalence, optic-vestibular 177
 — principle, Einstein's 103, 104
 equivalent signals 177, 178
 erect position, thresholds 82
 Erholungsnystagmus 484
 error correction 179
 — detection 179
 errors, compensatory 160
 estimation of angular displacement 44, 49, 51
 — of linear displacement 106
 — of plane of the utricle 98
 — of body tilt 83
 — of verticality 83, 84
 evaluation of caloric responses 220, 221
 Ewaldian cells 286, 288
 Ewald's law 430, 472, 514
 excitation and nystagmus 362
 excitement, vestibular responses to 361, 362
 exploration of space 251
 extensor plasticity 585
 — tonus 268
 external compensation 159, 174
 — ophthalmoplegia 275
 — spatial reference system 241
 extraocular muscle palsies 215
 — nerve palsy 215
 extrapersonal space, perception of 238, 261
 eye, see also ocular
 — deviations, pendular 211, 212
 — disease, Åland 211
 — field, frontal, function of 586, 592, 611 ff
 — fits, tonic 215
 eye-hand coordination 612
 — -head-body incoordination 612
 — movements, see also nystagmus, saccades
 — —, abnormal 239
 — —, clonic upward 215
 — —, compensatory 225, 234
 — —, involuntary 197
 — —, involuntary spontaneous, in blindness 210
 — —, nonnystagmic 212
 — —, pursuit 199
 — —, —, smooth 199, 215, 216, 219, 587, 588
 — —, rapid 362
 — —, rotatory 202
 — —, saccadic 216, 590, 591, 600
 — —, seesaw 203
 — —, spontaneous, and myorhythmia 213
 — —, vestibular 201
 — —, visual guided 215, 217
 — —, voluntary 600, 601
 — —, —, in blindness 211
 — — and angular oscillation in the yaw 313
 — —, disorder of 583
 — —, extraocular muscle afferents 586
 — — in fish 560
 — — after labyrinthectomy 451
 — — after neurotomy of the VIII nerve 451
 — —, seeing during 130
 — muscles 588
 — —, nuclei for 439
 — —, proprioceptive feedback from 599
 — — afferents, projection to the cerebellar cortex 598
 — — stretch 586
 — position in blind man 587
 — —, optokinetic and vestibular regulation of 197
 — —, stabilization of 194, 587
 — — control, neural mechanisms of 588
 — postures, vestibular stabilization of 583, 585, 587, 588
 — tracking, predictive 589
 fainting fits and vertigo 443
 fall, accelerated free 555
 fastigial nuclei 479
 fatigue and vestibular responses 361, 369
 fear of heights 195
 — reaction 125, 131
 feed-back, optical 169
 —, proprioceptive, from eye muscles 599
 —, visual 587
 — autocompensation 176
 — compensation 173, 176

- feed-forward compensation 173, 174
 fenestration operations 430
 Ferris wheel effect 112, 113, 545, 548, 550, 567
 fiber connections between cerebral cortex, cerebellum and basal ganglia 602
 field, see force-field, visual field
 — forces, inertial 236
 — potentials, vestibular nuclei 459
 fighter pilots 379
 figure skaters and nystagmus 376, 377, 379
 filter, high-pass 536
 —, low-pass 536, 562
 — mechanism 172
 filtering process, otolith organs 536
 finger-nose test 271, 608
 finish-horizontal mode of rotation test 342
 — -vertical mode of rotation test 342
 fish, behavior and vestibular organs 558 ff
 —, compensation of labyrinthine lesions 466, 472
 —, dorsal light reactions 178, 180
 —, eye movements 560
 —, frequency of canal stimulation 508
 —, inverted position 555
 —, ocular counterrolling 526
 —, otolithic cells 523
 —, otolith organs 165, 517, 519, 527
 —, positional tests 284
 —, semicircular canal responses 502, 508, 509, 510, 514, 552
 —, vestibular nerve 607
 —, vestibular organs 496, 558
 fixation, visual 222
 —, central regulation of 211
 — nystagmus 196, 198, 199, 208, 209, 210, 587
 flexion paraplegia 585
 flexor tonus 268
 flight, aerospace - 398, 400, 401, 402
 —, orbital 237, 254, 298
 —, parabolic 103, 235, 237, 252, 254, 298, 304, 416, 555, 556
 —, spatial disorientation in 281
 — personnel 104
 flocculo-nodular connections 126
 — lobe 126, 590
 — —, inhibitory function on vestibular organs 426
 flocculus 115, 116, 126
 floor standing tests 353
 — walking test 353
 force environment, manipulation of 235
 — —, effective, in a near-weightless vehicle 236
 — field on the body, change of 87
 — — on the head, change of 87
 force field dependence 110
 — — magnitude 97, 101
 — plates electrobasometer 359
 forces, agravitoinertial 236, 237
 —, centrifugal 165
 —, gravitational 236
 —, gravitoinertial 236, 237, 247, 261
 —, inertial immanent 236
 forebrain, relation to vestibulo-reticulo-cerebellar system 599
 — lesions 215, 216, 218, 222, 228, 475
 formatio reticularis, see reticular formation
 four-pole swing 234
 fovea 587, 599
 foveal fixation 587
 — smooth pursuit eye movements 587
 — vision, anomaly of 208
 foveate animals, nystagmus in 594
 Frenzel's glasses and nystagmus 198, 199, 200, 201, 202, 204, 221, 483
 frequency of stimulation of fish canals 508
 —, natural, of canal system 33
 —, —, of cupula-endolymph system 31
 —, —, of the sacculus 70
 — response of the utricle 71
 friction, internal, of the gelatinous substance 70
 Friedreich's atrophy 598
 frog, compensation of vestibular lesions 466, 467, 473, 475, 480
 —, with extirpated canals 543
 —, primary afferent neurons and linear acceleration 284
 frontal aphasia 614
 — eye field 586, 592, 611
 — lesions, Müller effect after 94
 — lobe syndrome 614
 frontoparietal lesions, Müller effect after 94
 function generator 599, 602, 603, 613
 galvanic methods, ataxia 359
 — nystagmus 220
 — stimulation 220, 270, 272
 — tests, clinical value of 435
 gamma-motoneurons 479
 — -spindle loops 479
 ganglia, basal, see basal ganglia
 gastric motility during motion sickness 400
 — ulcer and vertigo 438
 gastritis and vertigo 438
 gastrointestinal effects and motion sickness 400
 gaze, conjugate 215
 — apraxia 217
 — centers, subcortical 216
 — nystagmus 196, 198, 199, 214, 216, 219, 587, 605

- gaze paralysis 215
 — —, horizontal 216
 — —, vertical 217
 — paresis 218, 596
 — positions, eccentric 589
 —, hysterical pseudopalsy of 215
 gelatinous substance, friction of 70
 generator, function - 599, 602, 603, 613
 geometric displacement 134
 Gerlier's disease and vertigo 438, 441
 Gibson texture gradients 172
 glass model and motion sickness 408
 glaucoma, labyrinthine 561
 g level, increasing 244
 — loading, increased 259
 glucose, content during motion sickness 401
 goal-directed movements 583
 goniometers 357
 gradient for retinal texture density 168
 granular cells in cerebellar cortex 603, 605
 gravireceptor inputs, convergence of 287
 — stimulation, canal responses to 295
 gravireceptors, generally distributed 282
 —, nonvestibular 282
 — of otolith organs 282
 —, somatesthetic 282, 283
 —, vestibular 282
 — and habituation 381
 gravitational acceleration 287, 291, 542
 — —, effect on responses to rotation 291
 — — and lateral canals 292
 — —, sensation of 417
 — forces 236
 — — and ocular counterrolling 239
 — stimulus and otolith activity 241
 — vertical 261, 283
 gravitoinertial force environments, unnatural 257
 — forces 236, 237, 247, 261
 — horizontal 247, 248
 — vertical 245, 252
 — upright 247, 255
 gravity, absence of 252, 254
 —, constant stimulus of 259 f
 —, cupula deflection by 294
 —, lunar standard of 240, 254, 255
 —, measurement of 499
 —, orientation to 16, 293, 305, 309
 —, otolith response to 527, 533
 —, position relative to 18, 68
 —, specific, of cupula 285
 —, —, of endolymph 16, 303
 —, —, of otoliths 16
 —, tilted relative to 96
 —, zero-, see weightlessness
 — -dependent otolith signals 563
 gravity-orientation information, otolith system 105
 Grunddrehung 469
 guidance system, inertial 494, 495, 564
 guinea pig, compensation of vestibular lesions 469, 470, 473, 474, 476, 478, 479, 480
 gyroscope 498
 gyrus, postcentral 8
 habituation 362, 369, 382
 —, attention - 135, 136
 —, caloric 372, 373
 —, psychological 366
 —, situational 366
 —, vestibular 130, 134 ff, 361 ff
 —, vestibular sensation - 425, 426
 — from caloric to rotatory stimulation 373
 —, canal responses after 132
 —, central factors of 381
 — to constant rotation 342
 — to Coriolis stimulation 377, 382
 — of Coriolis vestibular responses 380
 —, nystagmus - 131, 134, 361, 370, 374
 —, oculomotor responses after 133
 — to sea-sickness 410
 — of turning sensation 134, 379
 —, room illumination during 379
 — of vestibular responses and visual stimuli 369 ff
 hair cells, semicircular canals 515
 — — in the utricle 69
 Hallpike's nystagmus 439
 hallucinations 432
 — of rotation 429, 433
 halteres of insects 500
 hand movements, goal-directed 612
 — —, visually guided, ataxia of 218
 haunted swing illusion 119, 160, 179
 head, force field on 87
 —, illusory rotation of 557
 —, orientation to gravity and otolith system 16, 537
 —, rotation of 121
 —, stimulus vector relative to - 16
 —, vestibulospinal reactions in 269
 — axes 10, 537
 — -fixed conditions during habituation 371
 — — orientation to the vertical 537
 — -free conditions during habituation 371
 — inclination 172, 176, 177
 — movements 121, 123, 124, 197, 537, 538, 539
 — —, caloric stimulation 269
 — —, disorientation by 556
 — — and motion sickness 558
 — — and nystagmus reduction 377
 — — during rotation 381
 — planes 10

- head position, regulation of 211
 — — other than vertical 204, 537
 — return 122
 — -shaking test 200, 201, 204
 — tilt 159, 172, 182
 — —, lateral 122
 — —, canal responses during 132
 — trauma 203, 204
 — tremor 208
 — -turning vertigo 196
 — -up judgements 89
 — — position, ellipse of uncertainty 89
 headache, occipital 195, 206
 — and vertigo 439
 hearing impairment, vertigo with 441
 — loss 195, 196
 heart rate and motion sickness 395
 hemianopsia 215, 218
 —, homonymous 217, 218
 hemilabyrinthectomy 452, 453, 454
 hemineglect 215
 hemispherectomy in animals 476
 hemispheric lesions, subcortical 218, 222
 — —, unilateral 217
 hen, nystagmus 373, 378
 hereditary deafness 436
 heredity of nystagmus 211
 heterocompensation 166, 169
 —, vestibular 165
 higher center commands 251
 history, clinical, of vertigo 194, 197
 Hörschwindel 195
 holding function, cerebellar 604
 — — of vestibular system 583, 603, 606
 — tremor 211, 227, 605, 606, 609
 homeostasis, postural, to the rotating environment 342
 homing 156
 horizontal, apparent 162, 241, 558
 —, gravito-inertial 247, 248
 —, visual 86
 —, perception of 91
 — acceleration at lunar standards of gravity 255
 — accelerators 106
 — canals, vestibular neurons of 454
 — gaze paralysis 216
 — linear acceleration, sustained 79, 107
 — — oscillation 83, 315
 — nystagmus 203, 207, 303, 483, 590
 horizontality, directional cues for 169
 human centrifuge 83, 95, 235, 239, 259, 392, 416
 hydrops, labyrinthine 438, 439, 561
 hyoscine 364
 hypergravic forces 240
 hypermetria 604
 hyperphoria 207
 hypersalivation during motion sickness 399
 hypersensitivity to motion sickness 407, 408
 hyperventilation and motion sickness 397, 400
 hypnosis, animal 362
 — and nystagmus suppression 365
 hypocapnoea and motion sickness 397
 hypometria of saccades 596, 598, 604
 hypotension, orthostatic 398
 hypothalamic lesions 613
 — stimulation 613
 hypothalamus 612
 hysteresis in the cupula 419
 illusion, audiogravimetric 432
 — of body movements 563
 —, Coriolis 553ff
 —, elevator 262
 — of falling forward 527
 —, ferris wheel 112, 113, 545, 548, 550, 567
 —, haunted swing 119
 —, inversion- 254, 262, 555, 556
 — of a magnitude 557
 —, oculogravic 72, 75, 95, 100, 104, 125, 165, 234, 245, 252, 257, 259, 262, 416, 542, 547, 551, 556, 558, 562, 563
 —, oculogravimetric 22, 299, 339, 380, 416, 429, 432
 —, optogravimetric 22
 —, somatogravic 104
 illusory acceleration 543, 548, 557, 561
 — direction of the vertical 556
 — linear sensation 563
 — rotation of the head 557
 — sensations of movement 540
 image velocity and visual acuity 128, 129
 imbalance of vestibulo-oculomotor innervation 453
 immersion in liquids 87
 — in "polycell" cellulose paste 87
 — in water 87, 89, 90, 91, 92, 93, 96, 112, 234, 235, 247, 248, 259, 544, 545
 impulse, angular 20, 121, 122
 —, angular velocity 20
 — stimuli 21
 inability to stand 195
 — to walk 195
 inattention to visual stimuli 612
 inclination, body - 181
 —, head - 172, 176, 177
 —, perceived 98
 —, postrotatory 276
 —, subjective 98
 —, swaying 276
 —, uphill 97

- incongruity of equivalent signals 178
 —, optic-vestibular 178
 indication time 72
 indicator of position 520
 individual differences in reactions to dis-
 cordant stimuli 126
 induced movement 172, 177
 — nystagmus 202, 212, 275, 322
 — sway 251
 — vestibular responses 220
 induction, directional 160, 178, 182
 — effect 181
 inertial field forces 236
 — forces, immanent 236
 — guidance system 494, 495, 564
 — navigation, basic principles of 498
 — —, three-dimensional 499
 — — system 496, 516
 — system, basic components of 500
 — —, three-dimensional case of 499
 — vector, change in 562
 infectious diseases and vertigo 438
 inferior olive and spontaneous eye movements
 213
 influenza, spasms in - 215
 information, angular velocity 112
 —, change-in-position - 18, 90, 112
 —, tactile 164
 —, vestibular, cognitive awareness of 135
 — content 57
 — flow diagram of voluntary actions 602,
 613
 — theory and subjective angular velocity
 56
 inhibition of caloric nystagmus 222
 —, cerebellar 453
 —, commissural 459
 —, contralateral, of type I vestibular neurons
 459
 —, Schiff-Sherrington - 481
 — of visual motion perception 197
 innervation, parasymphathetic 400
 —, vestibulo-oculomotor 453
 input of acceleration, sinusoidal 523
 — — —, step - 523
 —, labyrinthine 87
 —, sensory, see sensory inputs
 —, somatosensory 86, 87, 89
 —, visual 86
 insensitivity of the position sense 88
 insufficiency, cerebro-vascular 195, 336
 —, vertebro-basilar 195, 196, 207, 228
 integrating accelerometer 503, 520, 530
 intensity of nystagmus 201
 intention tremor 609
 interaction of angular and linear acceleration
 281, 284, 291, 312
 interaction, canal-otolith 121, 256
 —, intravestibular 104
 —, neuron-glia cells 566
 —, optic-vestibular 177, 185
 —, visual-vestibular 23, 104
 — of time-varying linear accelerations and
 angular accelerations 312
 interference function 158
 interfering variable 158, 177
 internal compensation 159, 174
 — friction of the gelatinous substance 70
 — pallidum 608
 — spatial reference system 241
 internalisation of attention 261
 interstitial nucleus 217
 intervening variable 158, 160
 intestinal worms and vertigo 438
 intoxication effects 130, 205, 210, 219, 223,
 229, 438, 441
 intracerebellar nuclei 583
 intracranial diseases 275
 intravestibular conflict, visual vertical during
 107
 — interactions 104
 introversion-extroversion scales 110
 inversion illusion 254, 262, 555, 556
 — of optokinetic nystagmus 208, 219
 — phenomenon 92
 invertebrates, compensatory mechanisms in
 465
 inverted position 82, 555
 involuntary eye movements 197, 210
 — reflex counter-movements 197
 ischemia of the brainstem 204
 ischemic disorders and vertigo 440

 jerk nystagmus 202, 203, 207, 210, 215, 228
 jerks, coarse fixation 212
 —, square-wave 212
 joint receptors 282
 joints, sensory inputs from 95
 —, intravertebral, information from 437
 judgement of angular displacement 44
 —, head-up 89
 — of postural positions 90
 — of verticality 84
 judgements, mean, accuracy of 84
 jumbling 439

 ketones, content during motion sickness 401
 key symptoms for topical diagnosis 227
 kinesthesia, TPK-receptor system 237
 kinesthesia receptors 262
 kinesthetic cues 163, 527
 kinetic type I vestibular neurons 457
 kinocilia, utricle 17, 518
 kinocilium hair 517

- Kippdeviationen 212
 Körperdrehreflexe 272
 Körperneigungsreflexe 272
- labyrinth, loss of 582
 — bleeding and vertigo 438
 — hydrops and vertigo 438, 440
 — inflammation and vertigo 438
 — malfunction 164
 — tonus 464
 — trauma 438, 439
- labyrinthectomy 309
 — and eye movements 451
 — and motion sickness 607
 —, unilateral 235
 —, —, compensation of 464, 483
 —, —, effect on vestibular neurons 454, 458
 — and vertigo 437
- labyrinthine artery occlusion 336
 — -defective (LD) individuals 87, 90, 94, 95, 114, 239, 240, 242, 247, 248, 251, 259, 260, 390, 418, 501, 528, 546, 547, 548
 — — and ataxia tests 324, 326, 327, 329, 330, 331, 333, 335, 336, 344, 345, 346, 347
 — destruction 268
 — —, acute 451 ff
 — —, chronic 451 ff
 — —, vestibular neurons after 451 ff
 — disorder and vertigo 438
 — dysfunction 87
 — fistula 206, 437
 — function, loss of - 164, 196, 197, 321, 324
 — —, pathology of 430
 — —, unilateral 87, 164
 — —, man without 93, 106, 111, 113, 114, 310
 — glaucoma 561
 — inputs 87
 — lesions 195, 196, 203, 206, 452, 463 ff
 — —, bilateral 472f
 — —, unilateral 465f, 483
 — —, compensation of - in man 482 ff
 — organs, tonic action of 452
 — pathophysiology 463
 — righting reflexes 277
 — signals 85
 — tilting reflexes 584, 585
- labyrinthitis 276
 — and vertigo 439, 440, 441
- labyrinths, blind spot of 417
 —, electrical stimulation of 220
 —, maintenance of equilibrium by 7
- lactate, content during motion sickness 401
- lag in the perception of tilt 108, 110
 — in the perception of the visual vertical 108
- lag-effects 82
 — —, oculographic 75, 107, 109, 125
- lagena, fish - 559
 —, function in equilibrium 559
- Lage-Nystagmus 437
- Lagerungsnystagmus 437
- lamina quadrigemina syndrome 484
- latency, somatogyral 27, 28
 —, "threshold" - 30
 — of vestibular response 37
- latent nystagmus 198, 207, 211, 219
- lateral geniculate neurons, vestibular influence on 130
- lateral-line stream receptor 607
- lateropulsion 271
- laterotorsion, caloric stimulation 269
 —, Menière's disease 269
- law, Mulder's 30
 —, Stevens' power 39, 41
- LD, see labyrinthine defective
- L-dopa, oculogyric spasms 215
- lead effect 111
- learning, habituation 382
- leghorns, nystagmus 373, 378
- lesions of area 8 611
 —, arteriosclerotic 205
 — in the basal ganglia 608
 — of the brain stem 196, 202, 216, 226
 —, bulbar 484
 — of the cerebellar nodulus 205
 — of the cerebellar nuclei 199, 217, 587, 605
 —, cerebello-cortical 589, 605
 — of cerebellum 226, 228
 —, cerebral 162
 — of cervical roots 206
 —, collicular 217
 —, cortical 216, 217
 — of the corticofugal fibers 587
 — of the diencephalon 214
 — of the flocculo-nodular lobe 590
 — on the floor of the fourth ventricle 221
 — of the forebrain 215, 216, 218, 222, 228
 —, frontal 94
 —, frontoparietal 94
 —, hypothalamic 613
 —, labyrinthine 195, 196, 203, 206, 452, 463 ff, 482f
 — of lobules VI and VII 598
 — of the MLF 214, 228
 — of the medulla oblongata 202
 — of the optic tract 218
 — of the orbital cortex 613
 — of otoliths 206
 — in the pallidum 608
 — of paravermis 598
 — of pontine tegmentum 203, 217

- lesions in the posterior commissure 217
 — of the posterior fossa 205
 — of the roof nuclei 478
 — of the sixth nerve 215
 — of the spinal cord 478, 480
 —, subcortical 217
 —, subcortical hemispheric 218, 222
 —, supramesencephalic 585
 —, tegmental 484
 — in the thalamus 608
 — of third nerve nuclei 215
 —, traumatic, of the statoacoustic nerve 195
 —, unilateral hemispheric 217
 —, vascular 214
 —, —, in cerebral hemispheres 484
 —, —, of the inner ear 195
 —, —, of the thalamus 484
 — of the vermis 598
 —, vestibular 463
 — of the vestibular nerve 196
 — of vestibular nuclei 195, 203, 205, 215, 221
 — of the vestibular system 198
 Leuchtbrille, see Frenzel's glasses
 light-headedness, orthostatic 336
 limbic system 126, 612
 limb joints, afferents from 584
 — proprioception 91
 — reflexes, tilting 194
 limbs, sensory inputs from 95
 —, vestibular innervation 268
 —, vestibulospinal reactions in 269, 270, 272
 line of regard, uphill inclination of 97
 linear acceleration 12
 — —, clinical value of 435
 — —, constant, stimulation by 550
 — —, direction of 81
 — —, effect on semicircular canals 546
 — — greater than 1 g 299
 — —, interaction with angular acceleration 281, 284, 291
 — —, magnitude of 111
 — —, modification of the response to angular acceleration by 281 ff
 — —, modification of thermal responses by 303
 — — and motion sickness 390
 — — and nystagmus 299, 300, 301
 — — and otolith function 67 ff, 415
 — —, sustained horizontal 79, 107
 — — tests 226
 — — vector, rotation of 309, 546, 548
 — accelerometer 496, 498, 520, 530
 — displacement estimates 106
 — motion and motion sickness 390
 — oscillation 308
 — linear sensation, illusory 563
 — sensors 500, 516
 — velocity, determination of 538 ff
 — —, measurement of 546
 — —, perception of 18, 68, 72, 77, 82, 87, 106
 — — sensation 106, 112
 liquids, immersion in 87
 lobe, flocculo-nodular 126, 426, 590
 —, parietal 8
 —, temporal 8
 lobuli V to VII, and saccades 598, 599
 locate-and-see 130
 long rotation technique 223
 loop, cupula-endolymph - 19
 —, gamma-spindle - 479
 loss of a labyrinth 582
 — of labyrinthine function 164, 196, 197, 321, 324, 326, 344
 — of vestibular function 332, 430
 Louis-Bar syndrome 583, 598
 lunar standard of gravity 240, 254, 255
 — walk 254, 261

 Mach-Breuer-Brown theory 283
 macula, saccular 282, 516
 —, utricular 80, 268, 282, 518, 543
 — epithelium 517
 maculae, directional polarization of cells 520
 —, otolithic 416
 —, utricular and saccular, relative to the head 17
 macular afferents, cyclical alteration in excitability 290
 — messages 163
 — receptors 252, 290, 312
 magnitude of angular acceleration 16
 — of linear acceleration 111
 — of the resultant 83
 — of static force field 96, 101
 — estimates of subjective angular velocity 39 ff
 malaise 115
 mammals, static function of otolith organs 165
 man, see also observer, patients
 —, blind, eye position in 587
 —, deaf 90, 95
 —, compensation of labyrinthine lesions 482 ff
 —, measurement of otolith function in 233 ff
 —, measurement of vestibular ataxia 321 ff
 —, measurement of vestibulo-spinal responses 267 ff
 —, nystagmus in 193 ff
 —, vestibular-defective 234, 252, 253

- man, vestibular habituation in 374 ff
 — with little or no vestibular function 95
 — without labyrinthine function 93, 106, 111, 113, 114, 310, 418
 manipulation of force environment 235
 Mann test 353
 mapping function 158
 marche en étoile 272
 masking of visual information 594
 mastoiditis 324, 326
 mathematical treatment of otolithic organs 521
 — — of the Steinhausen model 504
 measurement of acceleration 499, 514
 — of gravity 499
 — of otolith function 233 ff
 — of postural vertical 82, 84
 — of velocity 502, 514, 546
 — of vestibular ataxia 321 ff
 — of vestibulo-spinal responses 267 ff
 — of visual vertical 82
 measures, direct, of subjective angular velocity 43
 mechanical model of otoliths and semicircular canals 529
 mechanics of otolith system 68 ff
 mechanoreceptors 603, 605
 medial longitudinal fasciculus 214, 228, 268, 586, 588
 — — —, lesion of 214, 228
 — — — syndrome 214
 — rectus motoneurons 458
 medulla oblongata, lesions of 202
 — —, otoneurology 227
 membrane, otolith, displacement of 17
 memory of change-in-position 90
 — of changes in orientation 86
 — of direction 104
 — of dynamic sensory data 111
 — dependence 110
 —, long-term 614
 Menière's disease (syndrome) 117, 195 f, 196, 229, 235, 269, 277, 324, 333, 334, 336, 439, 440, 463, 483
 meningitis 91, 438
 —, basal, and vestibular sensation 432
 —, tuberculous, and vertigo 443
 — and vestibular ataxia 324, 326, 327, 330, 331
 meningoencephalitis, laterotorsion 269
 —, luetic, and vertigo 443
 mental tasks and nystagmus 362, 363, 374
 mesencephalic nuclei and nystagmus 590
 — tegmentum, gaze center 216, 228
 mesencephalon 203
 metamorphosis 162
 methods, velocity-matching 43, 44
 migraine attacks and vertigo 441
 miner's nystagmus 208, 210, 219
 mislocation, visual 197
 MLF, see medial longitudinal fasciculus
 model, adaptation- 64
 — of canal adaptation 509
 — of a canal with "endolymphatic" and "perilymphatic" systems 289
 —, mechanical, of otoliths and semicircular canals 529
 —, mathematical, of canal response 296
 —, physical, of the otolith 528 ff
 —, roller pump- 288
 —, Steinhausen- 503, 504, 506, 512
 —, torsion pendulum 19, 24, 30, 33, 41, 56
 modification of the Steinhausen model 506
 modulation, cyclic 111
 — by the position senses 92
 — of semicircular canal activity 126
 momentum, angular 120, 121
 monkey, angular acceleration detection 509, 510
 —, compensation of vestibular lesions 471, 472, 474
 —, otolith responses 532
 —, otolith structure 516, 518
 monocular fixation, nystagmus upon 207
 — optokinetic nystagmus 219
 — optokinetic stimulation 219
 Moro reflex 123
 mossy afferents, peripheral, to the cerebellar cortex 605
 motion, see also movement
 —, angular 391
 —, apparent 68, 593
 —, linear 390
 —, orbital 391
 —, orbiting 391
 —, passive, reception of 34
 — constancy 172
 — experience 179
 — —, perceived 114
 — perception 77
 — —, visual 197, 592, 593
 — sickness 74, 119, 120, 126, 130, 234, 239, 257, 258, 262, 333, 339, 345, 347, 389 ff, 414, 415, 425, 427
 — — and archicerebellum 607 ff
 — — and head movements 558
 — — and mental tasks 365
 — —, sensory aspects of 405 ff
 — —, suppression by drugs 401, 402
 — — theories 568
 — of the cupula 513
 — of the environment, apparent 197
 — in yaw 295
 motivation centers 612

- motoneurons, abducens- 458
 —, gamma 479
 —, medial rectus- 458
 motor cortex 600
 — —, input from 602
 — —, lesions of 217
 — —, tactile adjustment 609 ff
 — —, sensory afferents 610
 — —, vestibular afferents 8, 610
 — fields of the Rolandic fissure 610
 — learning 604
 — map of cerebral cortex 609
 — system, general 581 ff
 — —, method for analysis 582
 movement, see also motion
 —, goal-directed 583
 —, induced 172, 177
 —, natural, stimuli approximating 46
 —, passive 90, 135
 —, "pre-programmed" skilled 126
 —, relativ, between observer and target, visual acuity during 126
 —, saccadic-type 603
 —, vestibularly induced 194
 —, voluntary 589, 600, 601, 602, 608, 609
 —, whole-body 104
 —, illusory sensations of 540
 —, tactile control of 610
 — of visual surroundings 119
 Mulder's constant 30
 — law 30, 415
 Müller effect 86, 94, 96, 241, 244
 multi-planar angular acceleration 392
 multiple sclerosis 198, 199, 207, 208, 210, 212, 214, 219, 220, 226, 228, 229, 606
 muscle afferents, groupe-Ia 585
 — spindles 588
 — — and vestibular stimulation 277
 — vasodilatation and motion sickness 398
 muscles, antigravity- 268
 —, extraocular 215
 —, ocular 215, 588
 musculature, skeletal, tonic innervation 163
 mutism, akinetic 613
 myasthenia gravis 215
 myoclonus, ocular 212
 myopy and vertigo 438
 myorhythmia, palatal, and spontaneous eye movements 213
Myxine, vestibular organs 496

 narcosis and compensation of vestibular lesions 481
 — and vestibular sensation 425
 natural frequency 31, 33, 34, 70
 — movements 46
 natural redundancy 167, 168
 nausea 116, 119, 125, 131, 133, 390, 392, 557
 navigation, inertial, basic principles of 498
 —, inertial three-dimensional 499
 — system, inertial 496, 516
 near-weightlessness 237, 251, 261
 neck, vestibulospinal reactions in 269
 — afferents 584
 — contribution to eye stabilization 206
 — ligaments, deep, information from 437
 — proprioception 225, 479
 — reflexes after labyrinthine lesions 469, 471
 — —, symmetrical 585
 — —, tonic 271, 437
 — torsion 204
 neoplasm, paraneoplastic consequence of 213
 nerve, eighth, and motion sickness 390, 405
 —, —, neurotomy of 451
 —, —, tumors of 439, 440, 442
 —, —, and vertigo 439, 440, 441, 442
 —, extrocular 215
 —, sixth, lesion of 215
 —, statoacoustic 195
 —, third, lesions of nuclei 215
 —, vestibular 195, 196, 203, 275, 285, 459, 464
 nerves, sympathetic 400
 nervous system, autonomic 399
 neural integrator between vestibular and oculomotor nuclei 589
 — mechanisms of eye position control 588
 — organization of the strategy of action 612 ff
 neurasthenics, vestibular responses 361
 neuritis of the eighth nerve and vertigo 441
 —, viral, of the vestibular nerve 195, 203
 neuroblastoma, thoracic 213
 neuroleptic drug, intoxication by 215, 481
 neuroma, acoustic 196, 222, 228, 229, 324, 333, 335
 neuron-glia cell interactions 566
 neuronitis, vestibular 195, 336, 442
 neurons, afferent, primary 284
 —, canal- 509, 510, 552
 —, first- and second order, of ampullar receptors 287
 —, lateral geniculate, vestibular influence on 130
 —, oculomotor 598
 — of otolith organs, responses from 518, 519
 — of the putamen 608
 —, tonic 586
 —, vestibular, activity during recovery 454
 —, —, after labyrinthine destruction 451 ff

- neurons, vestibular, responses to acceleration stimuli 285, 290
- , —, second order 454
- , —, type I 454, 456, 457, 458, 459
- , —, type II 453, 454, 457
- newborns, vestibular sensation of 426
- nociceptive flexion reflex 585
- nodulus 115
- nomenclature of acceleratory stimuli 10
- for head axes and planes 10
- nonfoveate animals, nystagmus in 594
- non-system-bound responses 257
- normal system-bound responses 256
- normalization effect 162, 173
- nosology of vertigo 439
- nuclei, cerebellar 586, 587, 605
- for the eye muscles 439
- , fastigial 479
- , intracerebellar 583
- , mesencephalic 590
- , oculomotor 216, 455, 458, 589
- , pontine 217, 605
- , vestibular 116, 195, 203, 205, 215, 221, 261, 268, 285, 287, 290, 453, 459, 464, 479, 587, 589
- nucleic acids 482
- nucleus, dorsomedial 612
- , interstitial, and gaze 217
- , precommissural, and gaze 217
- , prestitial, and gaze 217
- nystagmic dysrhythmia 363
- reaction, Menière's disease 269
- — in opposite directions 371
- reflexes 454
- nystagmogenic zones of cortex 475
- nystagmography 199, 200, 202, 220, 221, 222
- nystagmus 36, 59, 60, 62, 112, 114, 115, 122, 127, 129, 257
- , see also eye movements
- , acquired 198, 199, 208, 210, 219
- , alcohol- 307, 365
- , arousal- 261, 363
- , Bechterew's compensatory 456, 457, 474, 477, 483, 484
- , caloric 115, 116, 202, 204, 221, 303, 304, 305, 306, 307, 322, 472, 587
- , —, habituation of 372, 376
- , —, inhibition of 222
- , cervical 436
- , compensatory 310
- , congenital 198, 202, 207, 208, 209, 210, 211, 219, 228, 426
- , convergence retractory 217
- , Coriolis- 339
- , direction-changing 302, 310, 561
- , direction-reversing 113
- nystagmus, dissociated 214
- , downward 128
- , epileptic 215
- , fixation- 196, 198, 199, 208, 209, 210
- , galvanic 220
- , gaze- 196, 198, 199, 214, 216, 219, 228, 587, 605
- , head-shaking 204
- , horizontal 203, 207, 301, 483, 590, 593
- , induced 202, 212, 275
- of the jerky type 202, 203, 207, 210, 215, 228
- , latent 198, 207, 211, 219
- , long-lasting central 202
- , miner's 208, 210, 219
- , neck-torsion- 204
- , ocular spontaneous 482
- , optokinetic 125, 174, 207, 215, 216, 484, 587, 590, 593
- , — monocular 219
- , —, inversion of 208, 219
- , otolith 68
- , parietic 216
- , pendular 198, 207, 208, 209, 210, 211, 219, 606
- , — fixation 587, 605
- , positional 195, 196, 201, 204, 290, 300, 301, 307, 336, 365, 590
- , —, pathology of 561
- , —, of the central type 205
- , —, cervical proprioceptive 206
- , — paroxysmal 205, 437, 439, 441
- , — peripheral 205
- , —, due to tumor 205
- , —, and vertigo 437, 439, 441
- , positioning 196, 202, 205
- , —, pathogenesis of 206
- , postrotatory 115, 225, 269, 285, 292, 294, 302, 453
- , —, duration after labyrinthectomy 455
- , primary 60, 118
- , recovery- 203, 204, 221, 484
- , retractory 228
- , reversing 548
- , rotating 202, 228
- , —, of the pendular type 203, 207
- , rotational 472, 483
- , rotation-induced 322
- , —, effect of anesthesia on 361
- , rotatory 214, 483
- , secondary 60, 63, 118, 508
- , seesaw 214, 215
- , semicircular canal- 116, 302
- , spontaneous 113, 195, 197, 198, 199, 200, 204, 210, 218, 227, 228, 454, 456, 483
- , — alternating 226
- , — pathological 198, 201, 202

- nystagmus, spontaneous peripheral 202
 —, — physiological 199, 201
 —, —, in animals 211
 —, —, direction of 202
 —, —, following head trauma 204
 —, sustained 300, 301
 —, — unidirectional 288
 —, swaying 276
 —, upward- 128
 —, vertical 113, 127, 590
 —, vestibular 116, 118, 194, 198, 212, 216,
 218, 452, 586, 590, 592
 —, —, experimental 197
 —, —, peripheral 272
 —, —, spontaneous 197, 199, 201
 —, —, induced by caloric, galvanic and rota-
 tory stimulation 220
 —, —, and visual acuity 127, 128, 129
 —, —, visual control of 131
 —, voluntary 214
 —, accommodation of 134
 — in achromatopsia 211
 —, adaptation of 134, 508, 510
 —, adaptation time constant of 296
 —, adjustment of 134
 — during alertness 362, 363
 — and angular acceleration 62
 — during backward pitch 128
 — and barbiturate intoxication 590
 — of the contralateral side 203
 — by Coriolis cross-coupled stimuli 124,
 527
 — and Coriolis illusion 554
 — and cortical stimulation 477
 —, cyclic modulation 113
 — in dancers 369, 376, 377
 — after deceleration 378, 548
 —, dependence on orientation of the head
 292
 —, directional difference in 129
 —, directional predominance of 452
 —, effect of orientation to gravity on 293,
 305, 309
 —, effect of time-varying linear accelerations
 308
 —, effect of vision on 116
 —, fast phase of 469
 — during forward pitch 128
 — in foveate and nonfoveate animals 594
 —, genesis of, role of otoliths and canals in-
 310
 —, heredity of 211
 — of indefinite duration 548
 — and labyrinthine lesions 452, 453, 454,
 455, 456, 458, 472, 483, 546
 — and lesions in different brain regions 484
 — and lesions of the corticofugal fibers 587
 nystagmus and lesions of flocculo-nodular lo-
 be 590
 —, and linear acceleration greater than 1 g
 300
 — and linear acceleration stimuli 550
 — in man 193ff
 — and Menière's disease 195
 — and mental tasks 362, 363, 374
 — and mesencephalic nuclei 590
 — upon monocular fixation 207
 — during off-vertical rotation 111
 —, plane of 302
 —, produced by a rotating vector and laby-
 rinthine function 310
 —, rapid phases of 217, 586, 588, 590, 592
 —, response to angular acceleration 291,
 302
 —, response to linear acceleration 546, 548
 —, reversal during deceleration 48
 — in sea-sickness 405, 407
 — and sensed rotation 549
 —, Steinhausen model of 506
 —, during stimulation of y-axes and z-axes 52
 —, stimulus of gravity during 261
 — and subjective angular velocity 66
 —, time constant of decay of 294, 295, 296,
 297
 — .cupulogram 421, 430
 — curve, methods of 429
 — diagnosis 202
 — habituation 131, 134, 370, 374
 — intensity 201
 — modification, induced by visual-vestibu-
 lar interaction 132
 — reduction 377
 — rhythm 586
 — suppression 35, 116, 118, 126, 127, 128,
 130, 302, 305, 362, 365, 370, 376
 — — and sensation 425
 — velocity, decay of 62, 111, 123
 objective angle of tilt 242
 — indicants of canal function 295
 — vertical 242
 observers, see also man, patients
 —, blindfolded deaf, orientation ability of
 90
 — immersed in "polycell" cellulose paste 87
 — immersed in water, see water immersion
 —, labyrinthine-defective (LD), see labyrin-
 thine-defective individuals
 — with spinal lesions 87
 — with unilateral labyrinthine function 87
 occipital headache 195, 206

- ocular counterrolling 68, 94, 103, 226, 234, 235, 239, 252, 259, 517, 525, 526, 554, 563
- countertorsion 159, 174, 178
 - disorders and vertigo 438
 - displacement, utricular and saccular influences on 102
 - muscle dystrophy 215
 - myoclonus 212
 - nystagmus, spontaneous 482
- oculogravic effect 96
- illusion 72, 75, 95, 100, 104, 125, 165, 234, 245, 252, 257, 259, 262, 416, 542, 547, 551, 556, 558, 562, 563
 - — delay 542
 - lag effect 75, 107, 109, 125
 - response 96
 - tilt 82
 - crises 215
- oculogyral effect 22, 117
- illusion 22, 299, 339, 380, 416, 429, 432
 - reactions, thresholds estimated from 35
- oculogyric spasms 215
- oculomotor apraxia 218
- control 130
 - effectors, tonic control of 454
 - neurons, atrophy of 598
 - nuclei, premotor apparatus 216
 - —, vestibular influences on 455, 458, 589
 - nucleus 214
 - response to accelerations 291
 - —, after habituation 133
 - — during horizontal oscillation 315
 - syndrom, abnormal 207
 - system and motion sickness 401
 - -vestibular system, species differences 583
- off-vertical rotation, responses to 111, 113, 234, 235, 262
- oliguria 401
- olive, inferior 213
- ophthalmoplegia, external 275
- , internuclear 214, 228, 229
- ophthalmoscope 207
- opsoclonus 212, 213
- optic, see also visual
- chiasma, section of 216
 - postural reflexes after labyrinthine lesions 471
 - tectum 217, 588, 604, 612
 - —, stimulation of, and saccades 592
 - tract, lesion of 218
 - vestibular ambiguity 179
 - — conflict situations 181
 - — equivalence 177
 - — incongruity 178
 - — interaction 177, 185
 - — orientation to the vertical 155 ff, 184
- optic-vestibular weight ratio 180, 181, 182, 185
- optical compensation 177
- determinants of the optic-vestibular weight ratio 181
 - direction cues 163, 166, 178
 - feed-back 169
- optogyral illusion 22
- optokinetic aftereffect 118, 119
- afternystagmus 125
 - disturbance 587
 - nystagmus 125, 174, 207, 208, 215, 216, 218, 219, 484, 587
 - reactions 174, 178
 - regulation of eye position 197, 199
 - roll component 127
 - stimulation 115, 116, 117, 118, 119, 127
 - —, monocular 219
 - — and motion sickness 401
- optostatic eye countertorsion 178
- responses 178
- orbital cortex 126, 613
- flight 237, 254, 298
 - motion 391
- orbiting without rotation 390
- spacecraft 103, 391
- orientation 155
- , body- 156
 - to gravity 293, 305, 309
 - of the head to gravity 16, 292
 - , memory of changes in 86
 - , perceptual 156
 - , optic-vestibular, to the vertical 155 ff
 - relative to the body 85
 - relative to the earth 112
 - , spatial 156, 194
 - to the vertical under water 249
 - ability, egocentric 91
 - — of blindfolded deaf observers 90
- orthogonality of space perception 162
- orthostatic hypotension 398
- light-headedness 336
 - vertigo 439, 441
- oscillation, angular 127, 312, 313
- of the apparent vertical 180
 - , damped 509
 - , horizontal linear 77, 83, 105, 106, 315
 - , linear 308
 - , phase reversals of 432
 - , rotatory, clinical methods 432
 - , side-to-side 87
 - , sinusoidal, thresholds estimated from 30
 - , vertical linear 77
- oscillatory after-reactions, periodically 434
- shear vectors 88
 - stimulation 76, 77
- oscillopsia 208, 210

- osteochondrosis 206
 otitis media 440
 otoconia 517
 otolith, physical model of 528ff
 — activity and gravitational stimulus 241
 — apparatus and vertical constancy 163, 166
 — -canal interactions 256
 — -detected earth reference 115
 — function and attenuated vestibular and nonvestibular cues 86
 — —, experimental methods of 234
 — — and gravity 235
 — — and linear acceleration 67ff
 — — in man 233ff
 — —, threshold stimuli for 75
 — membrane, displacement of 17
 — nystagmus 68
 — organ function and alcohol 258
 — — — and drugs 258
 — organs 178
 — —, anatomy of 517
 — —, blind spot of- 80, 242, 436
 — —, filtering process of 536
 — —, gravireceptors 282
 — —, gravitoinertial forces in near-weightlessness 237
 — — in lunar walk 254
 — —, mathematical treatment of 521, 530
 — —, perception of space 237, 261, 282
 — —, primary neurons of 518
 — —, responses from 517
 — —, stimulation by linear acceleration 415
 — —, transfer function of 531
 — —, left and right, relative function of 235
 — sickness 262
 — signals, acceleration-dependent 563
 — —, gravity-dependent 563
 — —, processing of 533ff
 — stimulation 86
 — — and motion sickness 391, 408
 — — and ocular counterrolling 525, 526
 — stimuli, dynamic 68
 — —, static 68, 261
 — system, acceleratory stimuli 16
 — —, angular velocity information 105
 — —, change-in-orientation information 105
 — —, gravity-orientation information 105
 — —, mechanics of 68ff
 — —, mode of stimulation 235
 — —, oculogravic illusion 245
 — —, orientation of the head to gravity 16
 — — and postural equilibrium 261
 — thresholds 86, 87
- otolithic cells, polarization of 518, 520
 — —, responses from 518, 519, 524, 525, 527, 529, 532, 533, 547
 — —, types of 515, 519, 520, 524, 525, 527, 529, 531, 532, 533, 547
 — input, stabilization of visual space by 242
 — maculae 416
 — signal processing 540
 otoliths 18, 121
 —, utricular 112
 — and determination of rotation 547
 —, displacement of 69, 70, 71
 —, dynamics of 69, 71
 —, fish- 559
 —, lesions of 206
 — as linear sensors 516
 —, plane sensitivity of 96
 —, role in habituation 373
 — and rotation of the body 543
 — in sea-sickness 405, 407
 — and semicircular canals, complementary working of 543
 —, specific gravity of 16
 otoneurology 193ff
 otosclerosis 275, 430, 431
 over-compensation 241
 overshoot 56, 58
 overstimulation of vestibular organs 568
 oxygen, content during motion sickness 401
- paleo-cerebellar connections 126
 paleocerebellum, motion sickness and 126
 pallidum, lesions in 608
 palsy, bulbar progressive 228
 —, extraocular muscle- 215
 —, extraocular nerve- 215
 —, post-traumatic pseudobulbar 336
 parabolic (aircraft) flights 103, 235, 237, 252, 254, 298, 304, 416, 555, 556
 paradox, Aubert-Fleischl 52
 paradoxical phase of sleep 261
 parallel fibers of the cerebellum 604
 — -swing rotation 549
 — swings, experiments with 106, 163, 416, 418, 435, 436, 541, 559, 562
 paralysis, abducens- 8
 — of cranial nerves and vertigo 439
 —, gaze- 215, 216
 —, vestibular 482
 parametric gain adjustment via climbing fiber action 604
 paraneoplastic cerebellar encephalopathy 213
 paraoxon 482
 parasymphathetic innervation and motion sickness 400
 parasymphatholytic action of drugs 402, 410

- paravermis, lesions of 598
 paresis, gaze- 218, 596
 parietal lobe 8
 Parinaud's syndrome 217, 228
 parkinsonism 215, 608
 paroxysmal positional nystagmus 205
 — — vertigo 196
 passive movement 90, 135
 pastpointing 239, 271
 patellar reflex 276
 path of body movement, perception during
 — off-vertical rotation 111
 — of passive movement 90
 patients, see also man, observers
 —, abnormally fatigable 361
 —, schizophrenic 365
 —, catatonic 361
 pattern building, vestibular sensation 424
 pattern-copy 426, 427
 pathology of vestibular sensation 413 ff
 peak cupula deflection 38
 pendular angular acceleration 223
 — eye deviations during angular accelera-
 — tion 211, 212
 — nystagmus 198, 203, 207, 208, 209, 210,
 211, 219, 587
 pendulum, overdamped 503
 —, spring- 81
 —, torsion- 415, 420, 502
 Pensacola Slow Rotation Room 338, 339,
 340, 343, 344
 pentetrazole 482
 pentobarbital 364
 perceived inclination 98
 — motion experiences 114
 — position 83
 perception, see also determination, sensation
 — of acceleration 554
 — of angular acceleration, thresholds of-
 — 23 ff, 432
 — of angular velocity 18, 56, 125
 — of body rotation 118
 — of displacement 106
 — of horizontal 91, 97
 — of linear velocity 18, 72, 77, 82, 87, 106
 — of motion 77
 — —, visual 592, 593
 — of orientation relative to the earth 112
 — of space 156, 162, 164, 237, 238
 — on starting the head movement 121
 — of tilt 18, 68, 77, 81, 96, 102, 108, 110,
 125
 — of upright 104, 238
 — of velocity 21
 — of verticality 68, 75, 82, 90, 91, 97, 103,
 108, 109, 163, 164, 177, 185
 perception and the vestibular system 566 ff
 perceptions during changing horizontal linear
 — accelerations 105
 perceptual coordinate systems 164
 — orientation 156
 — reconstruction 166
 — space orthogonality 162
 — space transformations 156, 164
 perilymph, blood in 206
 perilymphatic fluids 562
 — systems, model of a canal with 289
 peripheral mechanisms of habituation 373
 periodically oscillatory after-reactions 434
 perphenazine 481
 persistent rotation experience 112
 personal space, perception of 238, 261
 personality, unity of 614
 — dimensions 110
 perspiration during motion sickness 399
 perturbed system-bound responses 257
 perverted direction of caloric nystagmus 221
 pharmacology of compensations of vestibular
 — lesions 481 ff
 phase angle, stimulus response- 38, 73
 — — between the response magnitude and
 — stimulus velocity 33
 — reversals of the oscillations 432
 phasic secondary after-sensations 433
 phenobarbital 481
 phosphorus, content during motion sickness
 — 401
 photographic methods, ataxia 357
 photophobia pains 440
 physical model of the otolith 528 ff
 picrotoxin 481
 pigeon, compensation of vestibular lesions
 — 463, 465, 472, 477, 479
 —, vestibular habituation 371, 372, 373
 pilots, see also astronauts
 —, determination of the vertical 538
 —, vestibular habituation 376, 379
 pitch, forward, sensation of 123
 — axes 302
 — errors 89
 — -nystagmus 127, 128
 platforms, elevated 359
 —, tilting 357
 plugging experiments, semicircular canals
 — 543
 pointing experiments 239, 268, 270, 271
 polyneuritis 215
 pontine angle tumor 213
 — nuclei 605, 614
 — —, gaze paralysis 217
 — reticular formation 214, 586, 590
 — tegmentum, gaze center 216, 228
 — —, lesions of 203, 217

- pontine tuberculoma 590
 position, angular 18
 —, erect, thresholds 82
 —, head-up- 89
 —, inverted 82, 555
 —, perceived 83
 —, experience of 179
 — relativ to gravity 18, 68
 —, seated, thresholds of 81
 —, static 18, 92
 —, determination of 497f
 — indicator 520
 — receptors 163
 — sense, absence of 88
 — —, insensitivity of 88
 — —, modulation by 92
 — —, sensitivity of 89
 — sensing units 71
 — signaling, consistent 112
 — — during off-vertical rotation 111
 positional change indicator 520
 — nystagmus 195, 196, 201, 204, 205, 206,
 290, 300, 301, 307, 336, 365, 437, 439, 441,
 561, 590
 — responses in canal afferents 284
 — test 201, 284
 — vertigo 196, 206
 positioning of the line relative to the body,
 egocentric 95
 — nystagmus 196, 202, 205, 206
 positions, postural, and reduced somatosen-
 sory cues 88, 90
 —, —, and reduced vestibular and nonvesti-
 bular cues 90
 —, side-down, thresholds of 82
 —, standing 94
 —, starting 88
 positivity, pre-motion 600
 post-acceleration primary reaction 60
 postcaloric sensation 435
 postcentral gyrus 8
 posthabituation tests 133
 posterior commissure, lesions in 217
 — fossa, lesions of 205
 postrotational effects 341, 343
 postrotational canal responses 92, 119
 — reactions, secondary 427
 — responses, time constant of decay of 297
 — sensation of turning 115
 postrotatory inclination 276
 — nystagmus 115, 225, 269, 285, 292, 294,
 302, 455
 — sensation, adaptation of 429
 postural cue system 179
 — direction cues 163ff
 — disequilibrium 239, 257
 — equilibrium 250, 261, 333, 346, 352
 — postural equilibrium responses 156
 — — test battery 234, 250
 — homeostasis to the rotating environment
 342
 — positions 88, 90
 — reflexes 113, 163, 471, 472
 — sensations 164, 174
 — stability, rigid 251
 — standard 176
 — sway 251
 — tilt 76
 — tremor 609
 — upright 249
 — vertical 82, 83, 84, 90, 109, 125, 249
 — vertigo 336
 — posture, bibliography of 352
 potassium, content during motion sickness
 401
 potentials, cerebral, preceding voluntary mo-
 vements 600, 601
 —, readiness- 600
 power law 39, 41, 56
 practice, effect on visual acuity 130
 precommissural nucleus 217
 pregnancy and vertigo 438
 pre-motion positivity 600
 premotor apparatus for eye rotation 203
 — neuronal apparatus of oculomotor nuclei
 216
 pre-programmed skilled movement 126
 pressure on the body surface, distribution of
 163
 — receptors 237, 262, 282
 prestitial nucleus 217
 pretectal area 588
 — region, gaze center 216, 228
 primary after-reaction 61
 — post-acceleration reaction 60
 prism spectacles 160
 prisms, right-left reversing 131, 604
 —, displacement of visual field by 134
 —, distorted visual input by- 134
 procain and vertigo 437
 projection area, vestibular 8
 prolonged rotation 344
 proprioception, limb- 91, 584
 —, neck- 225, 479
 —, nonvestibular 330
 — and vestibular system 582
 proprioceptive cervical nystagmus 206
 — feedback from the eye muscles 599
 — inputs 338
 — mechanisms, nonvestibular 344
 protein content of endolymph 562
 — — during motion sickness 401
 proximal stimulus 158
 pseudo-Coriolis effect 119, 401

- pseudopalsy, hysterical 215
 psychic states, vestibular responses 361
 psychogenic disorder 336
 — — and vertigo 438
 psychophysical variable 158, 159
 pulsations of blood-vessels 251
 pupillary light reaction 217
 Purkinje axons 599
 — cells 587, 603, 605, 608
 — effect 119
 pursuit eye movements 199, 219, 587, 588
 putamen, neurons of 608
 pyknolepsia, petit mal attacks of 196
- rabbit, compensation of vestibular lesions 468, 473
 —, nystagmus 371, 372, 373
 rail ataxia test 327
 — method 357
 — test battery 250
 ramp generator, basal ganglia 608
 — movements, voluntary 589, 608
 Ramsay-Hunt syndrome and vertigo 441
 rapid eye movements 362
 ray, canal responses to angular velocity 502
 —, otolith responses 519
 — labyrinth, time constant 285
 reaction, post-acceleration primary 60
 —, secondary, as sign of adaptation 62
 —, subjective, to angular acceleration 21
 —, —, to semicircular canal stimulation 18
 — time 28
 readiness potential 600
 reafference principle 156
 reafferent component 172
 — sensory signals 605
 — volleys, rapid movements by 606
 reafferents 7
 receptors, ampullar 282, 283, 291, 312
 —, canal- 251
 —, joint 282
 —, macular 252, 282, 290, 312
 —, nonotolith, loss of cues from 248
 —, position- 163
 —, pressure 282
 —, somatosensory 251
 —, stimulated by linear and angular acceleration 282
 —, tension- 163
 —, touch 237, 282
 —, TPK- 234, 235, 237, 244, 245, 249, 251, 261
 reconstruction 156
 —, perceptual 166
 — principle 166, 169
 recovery, neuronal vestibular activity during 454
- recovery nystagmus 203, 204, 221, 484
 recruitment of cupula sensory cells 514
 redundancy 167, 178, 179
 —, natural 167, 168
 —, expectations 167, 168, 172
 reference axes, otolith organs 522
 reflex, Achilles tendon- 276
 —, antigravity stretch 585
 —, cervico-ocular 223
 —, Moro- 123
 —, nociceptive flexion 585
 —, patellar 276
 — actions relativ to the earth 18
 — arc, cortico-cortical 600
 — —, vestibulo-ocular 291, 586, 590
 — counter movements, involuntary 197
 — response gains 251
 — vestibular disturbances 257, 262
 reflexes, deep, to vestibular stimuli 276
 —, labyrinthine 584, 585
 —, labyrinthine righting 277
 —, nystagmic 454
 —, postural 113, 163
 —, security- 179
 —, tendon- 276
 —, tilting 194, 584
 —, tonic neck- 271, 437, 584
 —, vestibular, in the trunk 271
 —, vestibulo-autonomic 268
 —, vestibulo-ocular 268
 —, vestibulo-spinal 267, 268, 277
 — after labyrinthine lesions 469, 471, 472
 regulation, central, of fixation 211
 — of head position 211
 rejection syndrome, motion sickness 568, 570
 REM sleep 261, 364
 renal resorption during motion sickness 401
 representation, cortical vestibular 7
 repugnance, theory of 572
 residual ataxia 345
 respiration and motion sickness 400
 response curves, supraliminal 27
 — decline of sensation 426
 — duration, working equations 38
 — latency, threshold methods and working equations 37
 — magnitude, phase angle between- and stimulus velocity 33
 — reduction, habituation 382
 responses, non-system-bound 257
 —, normal system-bound 256
 —, perturbed-system-bound 257
 — to stimulation of semicircular canals 52ff
 resting discharge 286
 — tremor 608

- restoration, vestibular 451
restoring force, elastic, of cupula 29
resultant, magnitude of 83
— force, tilted to 96
retardation, viscous 29
reticular formation 257, 261, 426, 459, 469,
475, 479, 584, 586, 589
— —, pontine 214, 586, 590
— nuclei of brainstem 601
— —, step generator 599
— — of the tegmentum 217
— system, interplay with vestibular system
34
reticulospinal tract 268
retinal image velocity 117
— message 172
— stimulus field 181
— texture density, gradient for 168
— velocity, vision during vestibular nystag-
mus 128
retractory nystagmus 228
retrospective displacement estimation 51
return to upright, speed of 85
reverie and nystagmus 363, 365
reversal in apparent motion 68
— phenomenon 477
reversing prisms 604
rhythmic after-sensations 419
— stimulations 425, 426
Richtungsinduktion 160
right-hand rule of rotation 12
righting reactions, compensatory 277
— reflexes, labyrinthine 277
rigidity 608, 609
rigid postural stability 251
Risatarun 482
RNA 482
rodents, optokinetic nystagmus 219
Rolandic area 609, 610
Rolandic fissure 610
role of expectation 117
roll axes 302
— errors 89
— nystagmus 127
roller pump model 288
Romberg's test 250, 273, 276, 322
— —, classical 336, 353
— —, unipodic 353
roof nuclei, lesions of 478
room, rotating 338, 339, 340, 343, 344, 392
— illumination during habituation 379
roots, dorsal 479, 584
rotatable chambers 117
rotating chair, clinical use of 223
— environment 132
— —, postural homeostasis to 342
— linear acceleration vector 286, 546, 548
rotating nystagmus 202, 203, 228
— platform 131, 133
— room 338, 339, 340, 343, 344, 392
— surrounds 118
— water tank 545
rotation 269
—, constant, adaptation to 339
—, constant velocity- 111, 288
—, continuous 550
—, —, of the linear acceleration vector 309
—, earth-horizontal 234
—, eccentric 299
—, off-vertical 111, 113, 234, 235, 262
—, parallel-swing 549
—, prolonged 344
—, reversed, sensation of 56
—, steady 180
—, after-sensation of 418, 419
— of the body and otolith response 543
— of the body in space 547
—, determination of 547
— about an earth-horizontal axis 115, 116
— about an earth-vertical axis 116
— of the environment 547
—, hallucinations of 429, 433
— of the head 121
— of immersed subjects 544, 562
— of a linear acceleration vector 290, 546,
548
—, responses to-, effect of gravitational accel-
eration 291
—, responses to-, effect of sustained accel-
eration 298
—, right-hand rule of 12
—, sensation of 16, 115, 418, 419, 423, 427,
547, 549, 550
— of the striped field 170
— about a tilted axis 113
— aftereffects 92
— -dependent cells 549, 567
— detection 34
— experience, persistent 112
— -induced ataxia 344
— — nystagmus 322
— tests, clinical value of sensation in 427
rotatory acceleration 415
— autokinesis 242
— excitability tests 220
— eye movements 202
— nystagmus 214, 483
— oscillations, clinical methods 432
— stimulation 220, 272
— vertigo 437
route perception 156
Ruttin compensation 472

- saccade 197, 588, 605, 611
 —, see also eye movement
 —, coarse 596
 —, fast-phase- 128
 —, correction- 594, 596
 —, horizontal spontaneous 597
 —, hypometria of 596, 598, 604
 —, refractory period for 592, 593
 saccadic burst activity 586
 — — duration 603
 — eye movements, dysmetria of 596, 598, 603
 — — —, functional crossing of the mechanisms for 216
 — — — and rapid phases of nystagmus 590
 — function, discontinuous, of cerebellar cortex 602
 — pulse generator 594
 — reaction time 596
 — -type movements 603
 saccular influence on ocular displacement 102
 — macula 282, 516
 — —, relative to the head 17
 — — as tilt indicator 102ff
 — plane 103
 — sac 517
 — shear 82, 102, 103
 — signals, temporal patterning of 112
 — units, responses from 533
 sacculle 16, 17, 71, 98, 102
 —, equilibrium function 235
 —, natural frequency of 16
 —, sensitivity of 87
 —, static function 164, 165
 sacculus, see sacculle
 salivation during motion sickness 399
 satiation effect 162, 173
 sclerosis, disseminated, and vertigo 442
 scopolamine and motion sickness 402
 sea sickness 369, 405ff, 430
 seated position, thresholds 81
 Schiff-Sherrington inhibition 481
 — — phenomenon 479
 schizophrenic patients, nystagmus 365
 secondary nystagmus 63
 — reactions as sign of adaptation 62
 section of corpus callosum 216
 — of optic chiasma 216
 security reflexes 179
 seeing during eye movement 130
 — during vestibular stimulation 130
 seesaw eye movement 203
 — nystagmus 214, 215
 seizures, adverse 215
 self-rotation, inducing vestibular ataxia 338
 semicircular canal, see also canal
 — — activity, modulation of 126
 — — function 20, 106
 — — information, conflicting 108
 — — nystagmus 116, 302
 — — response, postrotational 119
 — — stimulation, subjective reactions to 18
 — — —, visual acuity during 126
 — — — and visual information 116, 177
 — — stimuli and habituation 132
 — — —, unnatural 135
 — canals, acceleratory stimuli to 14, 546, 551
 — — and angular acceleration 503, 509
 — — as angular sensors 501, 502, 509
 — —, appropriate stimuli 415
 — —, disturbance of 202, 206
 — —, frequency response 585
 — —, gravitoinertial forces in near-weightlessness 237
 — —, location of angular acceleration vector by 116
 — —, matched sets 54
 — —, mechanical model of 529
 — —, normal range of operation 505
 — — and otoliths, complementary working of 543
 — —, plugging experiments 543
 — —, responses of - in fish 502, 508, 509, 510, 514
 — —, response to linear acceleration 549
 — — and sea-sickness 405, 407
 — —, stimulus wave forms 20
 — —, three coplanar pairs of 14
 — —, turntable stimulation 18
 — —, velocity transducer 504
 — —, horizontal, response to stimulation of 52ff
 — —, vertical, response to stimulation of 52ff
 sensation, see also determination, perception
 — of angular velocity 424
 — of centrifugal acceleration 417
 — of change of position 418
 — for diving 123
 — for forward pitch 123
 — of gravitational acceleration 417
 — of linear movements 418
 —, response decline of 426
 — of rotation 16, 56, 115, 418, 419, 423, 427, 550
 — of tumbling 119
 — of turning, see turning sensation
 — during turning acceleration and deceleration 21

- sensation, climbing 123, 125
 —, illusory, of movement 540
 —, linear velocity- 72, 106, 112
 —, postcaloric 435
 —, postural 164, 174
 —, secondary 63
 —, tilting 87
 —, vertiginous 133, 380
 —, vestibular 7
 —, —, pathology of 413ff
 — cupulograms 28, 406, 408, 409, 421, 422, 423, 428
 — cupulometry 429
 — curve, methods of 429
 — threshold 430
 sensibility, deep 88
 sensitivity, directional 290
 sensorimotor cortex 609
 sensors, angular 500, 501
 —, linear 500, 516
 —, static position- 18
 sensory anchoring 244
 — arrangement 134
 — aspects of motion sickness 405ff
 — association areas 599
 — data, dynamic, memory of 111
 — inputs from joints 95
 — — from the limbs 95
 — — from TPK system 244
 — interactions on vestibular habituation 130
 — signals, reafferent 605
 shear, saccular 82, 102
 —, utricular 82, 85, 87, 89, 98, 99, 100, 102
 — component 68, 102
 — —, beyond 1 g 102
 — —, saturation effect 100
 — —, tangent function 100, 101
 — movement 517
 — vectors, oscillatory 88
 sheer 530
 shock 570
 Shuller tuning 499
 side-down positions, thresholds 82
 — -to-side oscillation 87
 sign of adaptation, secondary reactions as 62
 signal detection theory 36
 — redundancy 179
 signals, synergistic, from ampullar and macular receptors 312
 sinusoidal cupulometry 66
 — oscillation, thresholds estimated from 30
 — stimulus 21
 SISI tests 234
 skaters, after-sensation 427
 skaters, nystagmus in 376, 377, 379
 skeletal musculature, tonic innervation 163
 skin, anesthesia and postural judgement 88
 —, touch and pressure receptors 282
 — pallor and motion sickness 393, 399
 skull fractures 483
 sleep, REM- 261
 —, paradoxical phase of 261
 —, spontaneous nystagmus in- 201, 211
 —, stimulus of gravity during 261
 — and vestibular sensation 425
 sleepiness during motion sickness 400
 somesthetic gravireceptors 282, 283
 somatogravic illusion 104
 somatogyral effect 22, 26, 117
 — latency 27, 28
 — reactions, thresholds estimated from 35
 — thresholds 26
 somato-sensory afferents, influence on compensation of vestibular lesions 479ff
 — cues 93, 94, 113
 — —, attenuated 91
 — —, reduced, and postural positions 88, 90
 — discrimination of tilt 110
 — fields of the Rolandic fissure 610
 — inputs 86, 87, 89
 — mechanisms 261
 — receptors 251
 — signals 85, 112
 — system 83, 89, 94, 96, 121, 234
 — —, and otoliths 18
 somesthetic cues, eliminated 545
 — disorders and vertigo 438
 — factors 164
 — sensors and determination of rotation 547
 space, extrapersonal 237, 238, 261
 —, personal 237, 238, 261
 —, phenomenal 159, 179
 —, visual, constancy of 197
 —, exploration of 251
 —, nonvisually perceived direction of 249
 —, visually perceived direction in 238, 241
 — coordinates and cerebral lesions 162
 — perception, constancy of 156
 — —, orthogonality of 162
 — —, otolith organs 237, 261
 — platforms 117
 — sickness 402, 554ff
 — situation, adaptation to 557
 — transformation, perceptual 156, 164
 spacecraft, horizontal 244
 —, weightless 237
 spasms, oculogyric 215
 spatial disorientation in flight 281
 — movement patterns 604

- spatial orientation 156, 194
 — perception, conflicts in 555
 — reference system, internal and external 241
 specific gravity of endolymph 16, 303
 — gravity of otoliths 16
 speaking, strategy of 614
 speech, neural organization of 614
 — discrimination 234
 speed of return to upright 85
 — of turning 21, 22
 spinal cord, effect of vestibular stimulation on 268
 — —, influence on compensation of vestibular lesions 479ff
 — — lesions 478, 480
 — — —, observers with 87
 — regulations 585
 — transection 585
 spinocerebellar connections 481, 603
 spinoreticular afferents 481
 spontaneous nystagmus 113, 195, 197, 198, 199, 200, 201, 202, 203, 204, 210, 211, 218, 226, 228
 spot, blind 80, 242, 417, 436
 spring pendulum 81
 — system, damped 19
 Sprungbereitschaft 407
 square-wave jerks 212
 squint, concomitant 207, 208
 squirrel monkey, detection of angular acceleration 509, 510
 — —, motion sickness 427
 — —, otolith responses 532
 — —, otolith structure 516, 518
 SR, sharp Romberg, see Romberg
 stabilimeter 356
 stability, rigid 251
 stabilization, high-frequency 251
 —, low-frequency 251
 —, vestibular, of eye- and body postures 194, 583, 585, 587, 588
 stable-platform system 499, 564
 standard reference direction 174, 175
 stand eyes closed 250, 323
 — eyes open 250, 323
 — on a leg eyes closed 250, 323
 standing on the head 555
 — on the moon 556
 — on rails 357
 — positions 94
 starting positions 88
 star walking test 353
 static counterrolling 525, 526
 — force field, influence on tilt perception 96
 — otolith stimuli 68
 — position 91, 92
 static position sensor 18
 — responses of otolithic cells 519, 520, 525, 532, 533
 — tilt relative to gravity 81
 statisch-optische Verhältniszahl 180
 statoacoustic nerve, traumatic lesions of 195
 statoconical mass, motion of 290
 — plaque, torsion of 290, 312
 statokinesimeter 356
 statolith elimination, fish 472, 473
 Steinhausen Model 495, 503ff, 504, 506, 512
 step function, cerebellar 604
 — — generator 599, 603
 — movements, dysmetria of 605
 stepping in situ 273
 — test 226, 272, 273, 275, 354
 stereocilia 17, 517
 Stevens' power law 39, 41
 stimulation, caloric 220, 269, 270, 272, 274
 — by constant linear acceleration 550
 —, Coriolis 377, 383, 382, 527, 563
 —, electrical, of labyrinths 220
 —, galvanic 220, 270, 272
 —, hypothalamic 613
 —, optokinetic 115, 116, 117, 118, 119, 127
 —, — monocular 219
 —, oscillatory 76, 77
 —, rhythmic 425, 426
 —, rotatory 220, 272
 —, semicircular canal- 18
 —, sinusoidal 429
 —, thermal 220
 stimuli, acceleratory 10, 13
 —, approximating natural movements 46
 —, discordant, reactions to 126
 —, "impulse" 21
 —, otolith dynamic 68
 —, — static 68
 —, unpredictable 589
 —, vestibular Coriolis cross-coupling 123, 124, 125
 stimulus, acceleration-step 20
 —, distal 157, 158
 —, centrifuge- 79
 —, Coriolis torque 133
 —, gravitational 241
 —, proximal 157, 158
 —, sinusoidal 21
 — patterns, typical 20
 — response phase angle 38, 73
 — variables, otolith function 234
 — vector relative to the head 16
 — velocity, phase angle between- and response magnitude 33
 — of gravity, constant 259f
 — —, loss of 262
 strabismus 207, 215

- strain gauges 359
 strapped-on system 499, 564
 strategy of action, neural organization 599,
 612ff, 613
 — of speaking 614
 streptomycin and ataxia 324, 333, 334
 — and vertigo 438
 — intoxication 197, 223, 309, 431, 482
 stress effects and motion sickness 401, 571
 stretch reflex 585
 striate area, destruction of 218
 — cortex 611
 striola 530
 strio-nigro-pallidum 602
 strychnine 481, 482
 subclavian steal syndrome 196
 subcortical gaze centers 216, 217
 — lesions and gaze paralysis 217, 218, 222
 — white matter 228
 subgravity levels 235
 subjective angle estimation 424
 — angular velocity 39ff, 43, 44, 47, 54, 421,
 422
 — cupulogram 421, 422
 — displacement measures 48
 — inclination 98
 — indicants of canal function 295
 — linear velocity 68
 — reactions to semicircular canal stimulation
 18
 — reactions to simple angular acceleration
 21
 — responses in relation to otolith dynamics
 71
 — rotation aftereffects 92
 — tilt 80
 — velocity estimates 379
 — vertical 100
 — vestibular reactions 378
 subjects, see man, patient, observer
 submarine navigation 494
 superior colliculus 217, 596, 612
 suppression, mechanism of 296
 — of ampullar responses 302
 — of canal-dependent responses 123
 — of nystagmus 35, 116, 118, 126, 127, 128,
 130, 302, 305, 362, 365, 370, 376, 425
 — of sensations of turning 295, 296
 — of visual brightness perception 197
 —, central, of the signal from lateral canals
 294
 supragravity range 240
 — states 234
 supraliminal response curves 27
 supramesencephalic lesions 585
 suspension by straps 93
 sustained accelerations, caloric tests 304
 sustained accelerations, effect on responses
 to rotation 298
 — —, horizontal linear 79, 107
 — nystagmus 288, 300, 301
 sway, induced 251
 —, postural 251
 — motion, and vestibular-defective subjects
 252
 swaying inclination 275
 — nystagmus 276
 sweating during motion sickness 399
 swimming, without orientation sensitivity
 91
 swing, four-pole 234
 —, parallel 106, 163, 416, 435, 436, 541, 549,
 559, 562
 —, torsion- 223, 425, 427, 429
 —, two-pole 391
 — illusion, haunted 119, 160, 179
 sympathetic nerves and motion sickness 400
 sympathomimetic action of drugs 402
 synaptic endings, degeneration of 459
 syndrome, Cogan's 440
 —, Gerlier's 438, 441
 —, Louis-Bar- 583, 598
 —, Menière's, see Menière's disease
 —, MLF- 214
 —, oculomotor abnormal 207
 —, Parinaud's 217, 228
 —, Ramsay-Hunt 441
 —, rejection- (= motion sickness) 568, 570
 —, subclavian steal- 196
 —, Wallenberg's 202, 203, 227, 228, 442,
 484
 syphilis 214, 438
 syphilitic interstitial keratitis 440
 syringobulbia 202, 215, 226, 227, 228, 443,
 483
 tabes dorsalis 276, 438
 tactics of action 599, 602, 613
 tactile control of movements 610
 — direction cues 163
 — information 164
 tandem walking test 353
 tangential acceleration 282, 283, 286
 — component 83
 — displacements, otoliths 70
 target displacement 106
 — oscillation 127
 targets, observer-fixed 127
 tectum opticum 217, 588, 592, 604, 612
 tegmental lesions 484
 tegmentum, reticular nuclei of 217
 —, mesencephalic 216, 228
 —, pontine 216, 228

- temporal coordination of movements 605
 — lobe 8
 — — epilepsy 196
 — movement patterns 604
 — patterning of utricular and saccular signals 112
 tendon reflexes and vestibular stimuli 276
 tension receptors 163
 test pilots 232, 425
 texture gradients, Gibson 172
 — —, retinal 168
 thalamic afferents to area 8 612
 thalamus, vascular lesions of 484
 —, ventro-lateral 602, 608
 theory, bicomponent- 164
 —, signal detection 36
 —, torsion pendulum 37, 40
 thermal responses, modification by linear accelerations 303
 — stimulation 220
 — — of ampullar receptors 306
 thoracic neuroblastoma 213
 Thorner ophthalmoscope 207
 threshold, concept of 35
 — acceleration, working equations 38
 — determination by centripetal acceleration 79
 — — by extrapolation of supraliminal response curves 27
 — — with oscillatory stimulation 77
 — — by sustained horizontal linear acceleration 79
 — — by tilt relative to gravity 82
 — latency 30
 — shifts over time 34
 — stimuli for otolith function 75
 — stimulus, cupula deflection 284
 thresholds, somatogyral 26
 — for electrical excitation of vestibular neurons 453
 — of electrical vestibular nerve stimulation 459
 — for frequency response of vestibular neurons 454
 —, otolith- 86
 — for the perception of acceleration 432
 — of perception of angular acceleration 23 ff, 223
 — of positions 81, 82
 — of somatesthetic gravireceptors for linear and angular acceleration 283
 tilt, apparent 119
 —, body- 83, 162, 182
 —, dynamic 106
 —, head- 122, 132, 159, 172, 182
 —, initial 85
 —, oculogravic 82
 tilt, postural 76
 — relative to the force field 96, 97
 — relative to gravity 81, 82, 96, 98
 —, static 106
 —, subjective 80
 —, adaptation to 72, 90
 —, angle of 242
 —, discrimination of 106, 110
 —, discrimination of linear acceleration from 105
 — and high-magnitude linear accelerations 107
 — and oculogravic lag effect 107
 —, perception of 18, 68, 77, 81, 102, 108, 110, 125
 —, —, influence of static force field on 96
 —, underestimation of 106
 — chair 249, 435
 — —, hard 88
 — —, padded 87, 88
 — —, tilting on 83, 169
 — devices 93
 — information, saccule 98
 — —, utricular shear 98
 — positions, static 91
 — rooms 110
 tilted buildings 110
 tilting platforms 357
 — reflexes, labyrinthine 584, 585
 — — of limbs 194
 — —, vestibular 584
 — sensations 87, 392
 — on the tilt chair 83, 169
 time constant 285, 294, 295, 296, 297, 315
 — -varying linear accelerations 308, 312
 tinnitus 195, 196
 tipping reactions 269, 277
 — table 277
 tone, vestibular 452
 tonic actions of labyrinthine organs 452
 — activity of vestibular neurons 452
 — control of oculomotor effectors 454
 — eye fits 215
 — innervation of skeletal musculature 163
 — neck reflexes 271, 437
 — neurons 586
 — —, type I, vestibular 457
 tonus, arm- 227, 270
 —, body- 163
 —, extensor- 268
 —, flexor- 268
 — asymmetries in the vestibular system 484
 Tonus-Labyrinth 464
 topical diagnosis, key symptoms for 227
 torsion dystonia 608
 — pendulum 415, 420, 502

- torsion pendulum model (theory) 19, 24, 28,
 30, 31, 33, 37, 40, 41, 56
 — swing 223, 425, 427, 429
 touch, receptor system 237, 262, 282
 TPK receptor system 234, 235, 237, 244,
 245, 249, 251, 261, 262
 — sensory input, astronauts 244
 tract, vestibulo-spinal 479
 transducers, angular velocity 20
 transfer from caloric to rotational stimulation
 381
 — function of otolith organs 531
 transformation of spatial into temporal pat-
 terns 604
 transient acceleration 540
 trauma, acoustic 336
 traumatic lesions of labyrinths 203, 206
 — — of statoacoustic nerve 195
 treading test 272
 treadmill 359
 treatment of motion sickness 402, 410
 tremor 227, 605, 606, 608, 609
 Tretversuch 272
 trunk, vestibular reflexes 271
 —, vestibulospinal reactions in 269, 271
 tuberculoma, pontine 590
 tuberculous meningitis and vertigo 443
 Tullio effect 426
 tumbling sensations 119
 tumor and positional nystagmus 203, 205,
 207, 213, 214
 — and vertigo 438, 439, 440, 441, 442
 turning, speed of 21, 22
 — sensation 115, 299
 — —, accommodation of 134
 — —, adaptation of 134, 296
 — —, adjustment of 134
 — —, and angular acceleration 291
 — —, definition of the stimulus 40
 — —, effect of vision on 116
 — —, habituation of 134, 379
 — —, suppression of 295, 296
 turntable, secondary 390
 typhus and vertigo 438
- U deg, postural vertical 84, 85
 —, visual vertical 86
 Umkehrphänomen 477
 uncertainty, arc of, see arc of uncertainty,
 U deg
 —, ellipse of, see ellipse of uncertainty
 under-compensation 241
 underestimation of angular displacement 49
 — of tilt 106
 underwater two-axis gimbals system 89
 unilateral labyrinthectomized patients 235
- unilateral labyrinthine defective (UL-Ds)
 324, 333, 335, 336
 units, canal-dependent 112
 —, change in position- 72
 —, position sensing 71
 unity of personality 614
 uphill inclination of the line of regard 97
 upright, gravitational 239
 —, gravitoinertial 239, 247, 255
 —, postural 249
 —, perception of 104, 238
 —, return to 85
 uremia and vertigo 438
 urine during motion sickness 401
 utricle 14, 16
 —, estimated plane of 98
 —, frequency response 71
 —, hair cells in 69
 —, kinocilia 17
 —, static function 164, 165
 — shear plane 85
 utricular influence on ocular displacement
 102
 — macula 17, 80, 268, 282, 518, 543
 — otoliths, angular velocity information
 112
 — sac 517
 — shear, lateral 100
 — — component 82, 85, 87, 89, 98, 99
 — — —, physiological limits of 102
 — — hypothesis 99, 102
 — signals, temporal patterning of 112
 — units, responses from 533
 utriculofugal deflection 15
 — endolymph flow 453
 utriculopetal deflection 15
 — endolymph flow 453
 utriculus, see utricle
- variable, compensatory 173, 177
 —, interfering 158, 177
 —, intervening 158, 160
 —, psychophysical 158, 159
 vascular changes, motion sickness 393
 — collapse 195
 — disturbances and vertigo 438
 — lesions 195, 214, 484
 vasoconstriction and motion sickness 398
 vasovagal syndrome, vestibular stimulation
 398
 vector, inertial 562
 — analysis and static response of otolithic
 units 532
 —, acceleration- 12, 15, 79
 —, shear- 87, 88
 vegetative symptoms 195

- velocity, angular 18, 20, 21, 112, 113, 122, 125, 515
- , constant, adaptation for 515
 - , linear 18, 68, 106, 112, 546
 - , —, perception of 72, 77, 82, 87, 106
 - , slow-phase, nystagmus 62
 - , determination of 497f
 - , measurement of 502, 514
 - estimates, subjective 379
 - information, by canal-dependent units 112
 - -matching procedures 43, 44
 - perceptions 21, 77
 - ramps 20, 21, 24
 - step 21
 - triangle 21
- ventricle, fourth, lesions in 221
- Verhältniszahl, statisch-optische 180
- veridicality, ideal, deviations from 161
- vermis and motion sickness 607
- and saccades 598, 599
- vertebral artery, compression of 196
- vertebrobasillary circulation and vertigo 440
- insufficiency 195, 196, 207, 228
- vertical, apparent 86, 160, 162, 169, 170, 174, 176, 178, 179, 180, 181, 182, 241, 242
- , —, as a function of lateral body tilt 161
 - , —, in or out of water 248, 249
 - , gravitational 261, 283
 - , gravito inertial 245, 252
 - , objective 242
 - , postural 82, 83, 84, 90, 109, 125, 249
 - , subjective 100
 - , true 84
 - , vestibular 174
 - , visual 72, 82, 85, 92, 93, 95, 97, 100, 101, 107, 108, 109, 125
 - , determination of 534ff
 - , illusory direction of 556
 - , optic-vestibular orientation to 155ff
 - , sense of 540, 542, 562
 - canals, pathology of 432
 - constancy 157, 166, 172
 - gaze paralysis 217
 - indication, ability of 91
 - linear oscillations 77
 - nystagmus 113, 127, 590
 - writing test 270
- verticality, directional cues for 169
- , estimate of 83, 84
 - , judgement of 84
 - , perception of 68, 75, 82, 90, 91, 103, 108, 109, 163, 164, 177, 185
- vertige de l'enfance 440
- vertiginous sensations 133, 380
- vertigo 179, 194, 197, 205, 206, 227, 324, 336, 337, 392, 396, 414, 438
- , acute 439
 - , cervical 436
 - , childhood- 440
 - , chronic 439, 442
 - , concentration-camp- 438
 - , continuous 195
 - , epileptic 196, 439, 441
 - , head-turning 196
 - , long-lasting 195
 - , nonvestibular 438
 - , orthostatic 439, 441
 - , paroxysmal 439, 440
 - , positional 196, 206, 437, 441
 - , positioning 196, 437, 441
 - , posttraumatic 442
 - , postural 336
 - , rotatory 437
 - , spontaneous 437
 - , attacks of 195ff
 - and blood pressure 196, 438
 - , clinical history of 194, 197
 - due to disorders of the vestibular system 438
 - , general criteria 196
 - due to general disorders 438
 - without hearing disorders 441, 442
 - with hearing impairment 441
 - of labyrinthine origin 196, 438
 - , nosology of 439
- vestibular adaptation 369, 567
- afferents, projection to motor cortex 8
 - apparatus, phylogenetic connections with cerebellum 477
 - ataxia, measurement in man 321ff
 - compensation 177, 451
 - Coriolis cross-coupling effects 119, 120, 121, 125, 131
 - Coriolis cross-coupled reaction 133
 - Coriolis cross-coupling stimuli 124, 125
 - cortical activity 8
 - — projections 610
 - cues and otolith function 86
 - , reduced, and postural positions 90
 - -defective subject 234, 252, 253
 - defects, otolith function 234
 - direction cues 163, 164
 - excitability, diminished 212
 - eye movements, visual inhibition of 201
 - frequency response to angular acceleration 223
 - function, compensation of 460
 - , —, effect of poisons 481

- vestibular function, loss of 332, 430
- —, men without 95, 332
- —, systems approach to 565 ff
- gravireceptors 282
- habituation 134, 361 ff
- —, mechanisms of 134 ff
- — in man 374
- —, sensory interactions on 130, 134
- heterocompensation 165, 166
- influences on oculomotor nuclei 455
- — on lateral geniculate neurons 130
- information, cognitive awareness of 135
- innervation of limbs 268
- input-output relations 254
- lesions, compensation of 463 ff
- — and laterotorsion 269
- model 541
- nerve, see also nerve, eighth
- —, diseases of 275
- —, functional loss of 482
- —, recordings from 285
- —, threshold of electrical stimulation 459
- — and vertigo 438
- —, viral neuritis 195, 203
- — destruction 203
- — fibers, spontaneous activity in 464
- — lesions 196
- — neuritis 195, 336, 442
- — neurons, activity during recovery 454
- — after labyrinthine destruction 451 ff
- —, responses to acceleration stimuli 285, 290
- —, tonic activity 451
- —, second order 454
- —, type I 454, 456, 457, 458, 459
- —, type II 453, 454, 457
- — nuclei 261, 285, 584, 587, 589
- —, medial 268, 287, 290, 453, 479
- —, analogy in function with cerebellar nuclei 607
- —, field potentials in 459
- —, lesions of 195, 203, 205, 215, 221
- —, negative waves in 459
- — and optokinetic stimulation 116
- —, responses to acceleration stimuli 285
- —, spontaneous activity in 464
- nystagmus 116, 118, 127, 128, 129, 131, 194, 197, 198, 199, 212, 216, 220, 272, 477, 586, 590
- -oculomotor pathology 126
- — reflex system 130
- — organs as an inertial system 501
- — and motion sickness 390, 408
- —, overstimulation of 568
- —, self-adapting system 426
- —, specific stimuli of 414
- —, systems concept of 493 ff
- vestibular paralysis by streptomycin 482
- projection area 8
- receptors in elasmobranchs 284
- reflexes in the trunk 271
- regulation of eye position 197
- release to unidirectional angular acceleration 223
- representation, cortical 7
- response reduction 361
- responses, compensatory 295
- —, induced 220
- —, habituation of- and visual stimulation 369 ff, 373, 377
- —, modulation by intravestibular and visual-vestibular interactions 104
- restoration 451
- righting responses 156, 180
- sensations 7 ff
- —, direct and indirect 7
- —, attention to 67
- —, pathology of 413 ff
- sensors, resolution of acceleratory stimuli 13
- -somesthetic influences 181
- stabilization of body posture 194, 583
- — of eye position 194, 583, 585, 587, 588
- stimulation, effect on spinal cord 268
- — by multiplanar accelerations 393
- —, seeing during 130
- — and subjective responses 18
- stimuli and deep reflexes 276
- —, pattern and counterpattern 426
- structures, acceleratory stimuli to 10
- system and body control 500
- —, efferent 285
- —, holding functions 583
- —, interplay with reticular activating system 34
- —, lesions of 198
- —, motor functions 581 ff
- — and perception 566 ff
- —, pathological disorders 560
- —, proprioception and- 582
- —, tonus asymmetries in 484
- —, visual feedback to 604
- tilting reflexes 584
- tone 452
- tracts in the cerebellum 390
- vertical 174
- vertigo 195
- vestibularly induced movements 194
- vestibulo-autonomic reflexes 268
- cerebellum 604
- -ocular reflex arc 291, 586, 590
- — reflexes 268
- -oculomotor innervation, imbalance of- 453

- vestibulo-oculomotor symptoms 227
 - reticulo-cerebellar system 599
 - spinal disequilibrium 226
 - - reactions in head and neck 269
 - - - in lower limbs 269, 272
 - - - in upper limbs 269, 270
 - - - in tipping reactions 269
 - - - in trunk 269, 271
 - - reflexes 267, 268, 277
 - - responses, classifications of 269
 - - -, measurement of 267ff
 - - tests 226, 267ff
 - - tract 268, 479
 - vegetative disorders and motion sickness 402
- vibration, whole-body 126
- viral encephalitis 213
- viscosity of endolymph 507, 562
- viscous retardation 29
- visible surrounds, tilting of 109
- vision, blurred 195
 - , double 195
 - , dynamic, directional difference in 129
 - , foveal 208
 - , absence of, during rotation 116
 - , effect on nystagmus and turning sensations 116
 - and motion sickness 401
 - during vestibular nystagmus 127, 128
 - detected earth reference 115
- visual, see also optic
 - acuity, dynamic 130
 - -, effect of alcohol on- 130
 - -, effects of practice on 130
 - - during semicircular canal stimulation 126ff
 - - and image velocity 128, 129
 - afterimages 106
 - attention 612
 - autocompensation 169
 - brightness perception, suppression of 197
 - control of vestibular nystagmus 131
 - - of the vestibulo-ocular reflex arc 590
 - direction cues 166
 - feedback 587, 604
 - field, displacement by prisms 134
 - - dependence 104, 109, 110, 117
 - - independence 104, 109
 - fixation, influence on caloric response 222
 - frame, effect on the visual vertical 109
 - - of reference 109
 - holding function 588
 - horizontal 86, 97
 - image, fixation during head movement 502
- visual induction 182
 - information and apparent rotation about an earth-vertical axis 116
 - -, masking of 594
 - - and semicircular canal stimulation 116
 - inhibition of nystagmus 376
 - - of vestibular eye movements 201
 - input 86
 - - of the archicerebellum 604
 - -, distorted, by prisms 134
 - mechanisms and somatosensory input 244
 - mislocation 197
 - pathway to the cerebellum 604
 - perception of motion 197, 592, 593
 - - of verticality 177
 - postural reflexes, compensation of loss of both labyrinths 472
 - reference versus body reference 106
 - space, stabilization by otolithic input 242
 - - constancy 197
 - stabilization of eye position 587
 - still-fixation and nystagmus 375, 378
 - stimulation and habituation of vestibular responses 369ff, 373, 377
 - - and vestibular Coriolis cross-coupling effects 125
 - stimuli, inattention to 612
 - suppression 117
 - - of caloric nystagmus 116
 - - of vestibular nystagmus 35, 126, 127, 128, 130
 - surroundings, movement of 119
 - system 234
 - -, compensation of vestibular function 460
 - vertical 72, 82, 85, 92, 93, 95, 97, 100, 101, 108, 109, 125, 177
 - - during intravestibular conflict 107
 - -vestibular interactions 23, 104, 132
 - - interplay 127
- visually perceived direction in space 238, 241
- voluntary actions 613
 - eye movements 211, 600, 601
 - movements, cortical organization 600
 - nystagmus 214
 - ramp movements 589, 608
- vomiting 125, 131, 133, 195, 569
- walk eyes open 323
 - on floor eyes closed 323
 - , heel-to-toe 323
 - a line eyes closed 323
 - , lunar 254, 261

- walk a straight line 250
- walking, blindfold 272
 - deviation 272
 - experiments 268, 272, 353, 357
 - at night 321
 - on rails 357
- Wallenberg's syndrome 202, 203, 227, 228, 442, 484
- waltzing test 272, 354
- water immersion 87, 89, 90, 91, 92, 93, 96, 112, 234, 235, 247, 259, 544, 545, 562
 - — and apparent vertical 248, 249
- wave machine 390
- waves, negative, in vestibular nuclei 459
- weightless spacecraft 237
- weightlessness 104, 234, 237, 244, 262, 298, 307, 308, 398, 402, 545, 555
 - , caloric tests 304
- Wernicke's aphasia 614
- Wernicke's posture 585
- wheel effect 112, 113, 545, 548, 550, 567
- white matter, subcortical 228
- whole-body angular oscillation 127
 - displacement relative to the earth 106
 - movement 104
 - vibration 126
- wobble board 357
 - detection during constant speed off-vertical rotation 113
 - meter 357
- yaw, angular oscillation in 312, 313
 - , motion in 295
 - -nystagmus 127
- yawning during motion sickness 400
- zero gravity, see weightlessness
 - -g experiments 103, 555