

2013

San Antonio Condensate Collection and Use Manual for Commercial Buildings

Diana D. Glawe

Trinity University, dglawe@trinity.edu

Follow this and additional works at: https://digitalcommons.trinity.edu/engine_faculty

Part of the [Engineering Commons](#)

Repository Citation

Glawe, Diana, D. (2013). *San Antonio Condensate Collection and Use Manual for Commercial Buildings*. San Antonio: San Antonio Water System.

This Article is brought to you for free and open access by the Engineering Science Department at Digital Commons @ Trinity. It has been accepted for inclusion in Engineering Faculty Research by an authorized administrator of Digital Commons @ Trinity. For more information, please contact jcostanz@trinity.edu.

San Antonio

Condensate Collection and Use Manual for Commercial Buildings

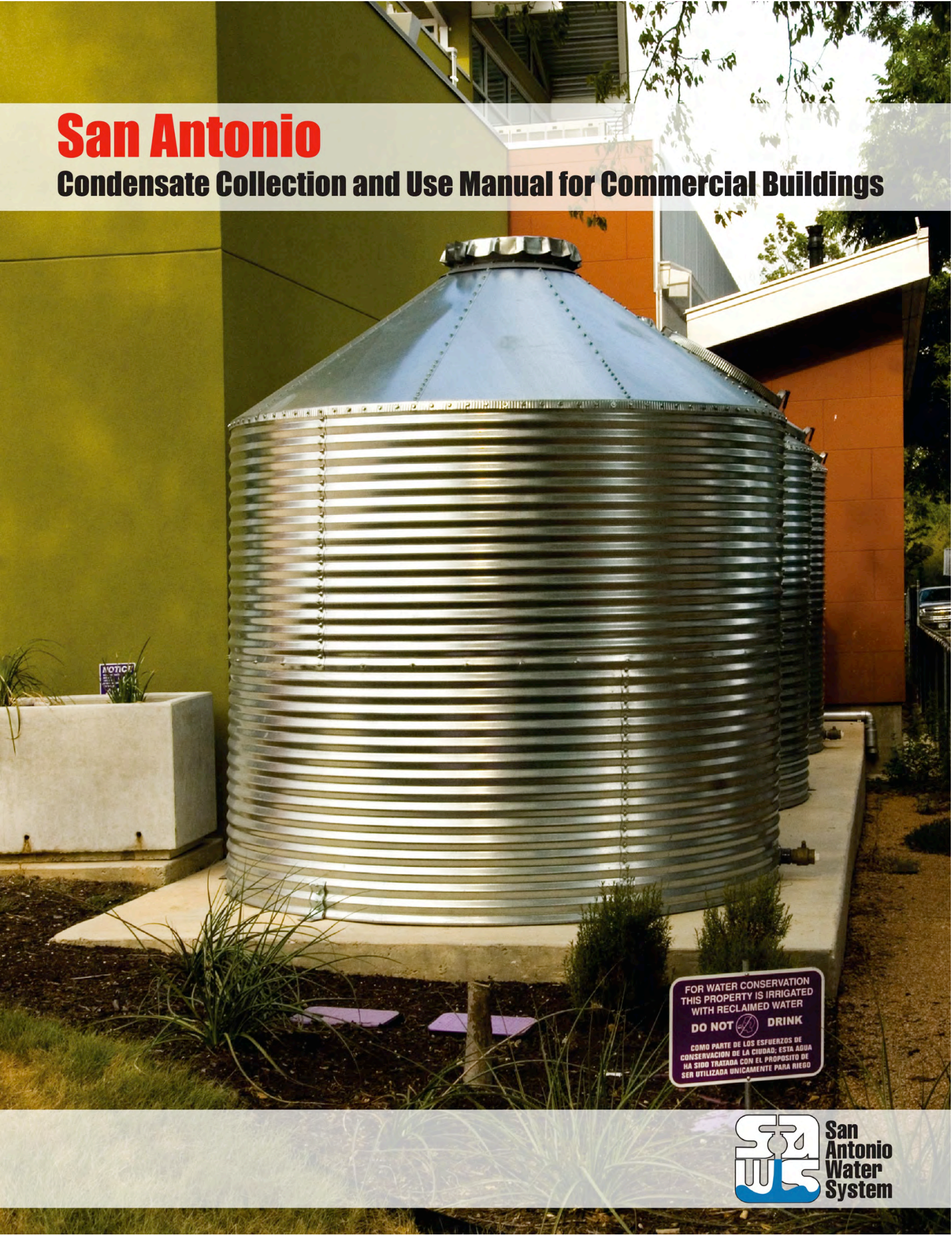

San Antonio Condensate Collection and Use Manual for Commercial Buildings

Published by San Antonio Water System

© 2013 San Antonio Water System

All rights reserved. No part of the publication may be reproduced without prior permission from the publisher.

Portions of this publication reproduce excerpts from the *2012 International Plumbing Code*, the *2012 International Mechanical Code*, and the *2012 International Green Construction Code*, International Code Council, Inc., Washington, D.C. Reproduced with permission. All rights reserved. www.iccsafe.org

About the Author

Diana D. Glawe, PhD, PE, LEED AP, is an Associate Professor in the Engineering Science Department at Trinity University in San Antonio, Texas, and serves as a consultant through her company, Glawe Works Incorporated. Her broad experience over the past 20 years across industry, non-profit, academic, and government sectors directs her vision toward a balance of research, education, and policy in addressing challenges facing society. She can be reached at glaweworks@gmail.com.

Disclaimer

The statutes and regulations described in this document may contain legally binding requirements. Neither the summaries of those laws provided here nor the approaches suggested in this document substitute for those statutes or regulations; these guidelines are not regulations. The author, contributors, editors, and publisher do not assume responsibility for the validity of the contents of this document or any consequences of their use. The appearance of any technical data or editorial material in this publication does not constitute endorsement, warranty, or guaranty of any product, service, process, procedure, design, or the like. In no event will San Antonio Water System (SAWS) or the author, contributors, editors, or publisher be liable for the direct, indirect, special, incidental, or consequential damages arising out of the use of information presented in this manual. In particular, the aforementioned parties will not be responsible for any costs, including, but not limited to, those incurred as a result of lost revenue. The entire risk of the use of any information in this publication is assumed by the user.

Cover photo: Eagle Veterinary Hospital, San Antonio, TX

Photographed by DesignPro Studio—Ugur Kilic

Contents

Preface	iv
Acknowledgments	vi
1 Introduction	1
What Is Condensate?	1
Heating, Ventilation, and Air-Conditioning (HVAC) Systems.....	1
Applications of Condensate	2
Relevance of Condensate Collection in San Antonio	2
Reasons for Failure	3
2 Codes and Standards	5
International Codes and Standards	5
Texas Administrative Code	7
City of San Antonio Codes and Ordinances	9
International Green Construction Code	9
Watering Restrictions Imposed by San Antonio Water System	10
Permits Required in the City of San Antonio	11
3 Condensate Water Contaminants	12
Metals	12
Pathogenic Microorganisms	13
Algae	14
Byproducts of Treatment.....	14
4 Water Treatment Methods	16
Treatment Train.....	16
Screening	17
First Flush	17
Sedimentation.....	17
Mechanical Filtration.....	17
Carbon Adsorption	18
Ozonation	18
Ultraviolet Light.....	19
Chlorination.....	19
Pasteurization.....	20
Advanced Oxidation Process	20
Reverse Osmosis.....	21

5	Water Quality Requirements, Guidance, and Monitoring	23
	Water Quality Requirements.....	23
	Water Quality Guidance.....	24
	Setting Water Quality Objectives.....	30
	Water Quality Monitoring.....	30
6	Selection of Water Treatment Methods for Common Applications	32
	Cooling Tower	33
	Process Water	34
	Subsurface Irrigation.....	34
	Above-Ground Irrigation.....	34
	Trap Primers	35
	Water Features	35
	Flushing of Water Closets and Urinals	35
	Drinking (Potable) Water	36
	Other Applications.....	36
7	Condensate Rate Predictions	37
	Rules of Thumb	37
	Water-Carrying Capacity of Air	39
	Instantaneous Condensate Flow Rate	39
	Simplifying Assumptions and Estimates for Constant Volume Systems	43
	Condensate over Time	45
	Building a Water Budget	50
	Maximum Condensate Flow Rate Calculations	52
	Improvements in Condensate Rate Predictions.....	53
8	Design and Implementation Process	55
	Schematic (Conceptual) Design Phase.....	56
	Design Development Phase.....	56
	Construction Documents Phase.....	57
	Construction Phase.....	57
	Commissioning Phase	57
	Start-Up Operation and Maintenance Phase	58
9	Condensate System Components	59
	Condensate Lines	59
	Separation of Water Lines	60
	Condensate Drain System Seals	62
	Water Meters.....	66
	Water Storage Tanks	71
	Makeup Water, Backflow Preventer, and Air Gap	75
	Water Level Sensors and Indicators.....	75
	Quick Disconnects Versus Hose Bibs.....	76
	Appurtenances	76
	Valve Seals	76
	Cleanouts	77
	Distribution Pumping and Control System	77
	Treatment System	77

10	Labeling and Signage	79
	Identification of Recycled Water Piping from SAWS Supply to Point-of-Use	79
	Identification of Reclaimed Water Piping from Source to Storage Tank.....	81
	Identification of Reclaimed Water Piping from Storage Tank to Point-of-Use	81
	Identification of Reclaimed/Recycled Water Appurtenance and Point-of-Use.....	81
11	Testing, Inspection, and Maintenance	84
12	Payback Period	87
13	Reduction of Carbon Dioxide Emissions	92
14	Definitions	94
	Appendixes	101
	Appendix A: Threshold Levels for Level I Industrial Reclaimed Water	101
	Appendix B: Sampling Record Sheet.....	102
	Appendix C: Common Waterborne Pathogenic Microorganisms	103
	Appendix D: Condensate Production Prediction	104
	Appendix E: Condensate Collection System Design & Implementation Checklist	105
	Appendix F: Test, Inspection, and Maintenance Checklist	107
	Appendix G: Cross-Connection Test and Detection Plan	108
	Appendix H: Projected SAWS General Class (Commercial) Water and Sewer Rates	109

Preface

Collecting condensate from commercial building heating, ventilation, and air-conditioning (HVAC) systems is relatively simple. Using condensate for on-site applications offers a potentially quick return on investment, especially in hot and humid climates. To help increase the implementation of condensate use, this manual was created as a guide for building managers, architects, engineers, and facility personnel to facilitate the comprehensive evaluation, design, and implementation of a condensate collection and use system for commercial buildings in San Antonio.

Condensate is an inherent byproduct of building HVAC systems. Since condensate is formed from moisture in the air, it is relatively high-quality water. Therefore, it can be collected and used on-site with relatively little treatment. Using condensate conserves municipal water and lowers energy costs associated with the municipal collection, treatment, and distribution of water that would otherwise be consumed. Moreover, sustainable building practices limit the amount of potable water used for landscaping irrigation, ornamental fountains, and numerous building applications, making on-site use of reclaimed water beneficial to these functions [GPMCS, IGCC].

For the purposes of this manual, “reclaimed water” is water from on-site sources such as HVAC condensate collection, rainwater harvesting, carwashes, ponds, lakes, rivers, or other sources as approved by the San Antonio code official [SAPC]. “Recycled water” is water that, as a result of a tertiary treatment of domestic wastewater by a public agency such as San Antonio Water Systems (SAWS), is suitable for a direct beneficial use or a controlled use that would not otherwise occur [SAPC]. The Texas Commission on Environmental Quality (TCEQ) must approve the level of treatment and quality of the reclaimed and recycled water [SAPC].

This manual focuses on reclaimed condensate water from commercial HVAC systems. However, recycled water provided by SAWS is commonly used as a backup to supplement the supply when needed (i.e., as makeup water) in reclaimed water systems. Since recycled water is commonly an integral component of a reclaimed water system, relevant information on recycled water is included in this manual. Similarly, relevant information on rainwater harvesting is provided, since rainwater and condensate are commonly stored in the same tank and treated together for future use.

Federal, State, and City of San Antonio requirements are integral to the guidance in this manual. These requirements, dictated by codes, are referenced in this guide using the square-bracketed notation [CODE § ####.#], where “CODE” refers to one of the relevant codes and the “#” numbers following the “§” section symbol are section numbers within that code.

In many cases the exact wording from the referenced code source is included in the text of this manual without quotation marks (to avoid continuous clutter), and at other times the information is paraphrased or summarized for readability. The summaries of regulations provided and the approaches suggested in this document are not substitutes for those regulations, nor are these guidelines themselves any kind of regulation. Since some details may be missing, consulting relevant codes directly for full details during the design-development phase is advised.

Note that the International Green Construction Code (IGCC) and the Green Plumbing and Mechanical Code Supplement (GPMCS) are intended “to require higher minimum standards related to building performance than the corresponding minimum reference codes and standards.” As such, since San Antonio does not require these higher standards, references to the IGCC and GPMCS are presented as recommendations rather than requirements.

Below is a list of acronyms used in this manual to represent relevant codes:

GPMCS = 2012 Green Plumbing and Mechanical Code Supplement (IAPMO)

IBC = 2012 International Building Code (ICC)

IGCC = 2012 International Green Construction Code (ICC)

IMC = 2012 International Mechanical Code (ICC)

IPC = 2012 International Plumbing Code (ICC)

SAPC = San Antonio Plumbing Code, 2012 IPC with amendments
per City Ordinance 2011-12-01-0984

SAMC = San Antonio Mechanical Code, 2012 IMC with amendments
per City Ordinance 2011-12-01-0984

SAWCR = San Antonio Water Conservation and Reuse
per City Ordinance 2013-02-07-0082

TAC = Texas Administrative Code (TCEQ)

Since codes and standards are updated on a regular basis, care must be taken to check for code updates subsequent to the publication date of this manual. Similarly, if the guidance herein is to be applied outside San Antonio, check with the appropriate state and local jurisdiction for applicable requirements. Always check the primary referenced source for full details.

Acknowledgments

The author, Diana Glawe, would like to acknowledge the following individuals for sharing expertise in their respective fields as input or toward comments in review of this manual.

<i>Name</i>	<i>Affiliation</i>	<i>Expertise Related to Manual</i>
Tom Bruursema	National Sanitation Foundation	Water Reuse Standards
Cesar Garcia	MDN Architects	Design and Implementation
Richard Grant	Trane Commercial Systems	Air-Conditioning Systems
Bill Hoffman	H. W. Hoffman & Associates	Codes and Standards
Tres Koenings	Texas Commission on Environmental Quality	Texas Administrative Code
Tom Lawrence	University of Georgia	Condensate Rate
Dennis Lye	Environmental Protection Agency	Waterborne Pathogens
Shawn Martin	International Code Council	Codes
Tom Meacham	Mueller Systems	Water Meters
Steve Mechler	Steve Mechler & Associates	Reclaimed Water Systems
Bruce Rathburn	San Antonio Water System	Labeling and Signage
David Rohde	City of San Antonio	San Antonio Plumbing Code
Brian Soderholm	Water Control Corporation	Water Treatment
Warren Trent	Trent Technologies	Drain Seals
Charlie Trowbridge	San Antonio Water System	Labeling and Signage
Phil Weynand	San Antonio Water System	Water Metering

1

Introduction

What Is Condensate?

Condensate is defined as water that collects on a cool surface because the temperature of the surface is below the point at which moisture in the air forms water droplets. As one would expect, the more moisture the air holds, described in terms of humidity, the greater the potential for condensate to form. A classic example of condensate formation takes place on the outer surface of a glass of ice water set outside on a hot and humid day (see Figure 1.1).



Figure 1.1 Condensate on glass

Heating, Ventilation, and Air-Conditioning (HVAC) Systems

Similarly, condensation occurs in heating, ventilation, and air-conditioning (HVAC) systems of commercial buildings. More specifically, condensate occurs in the evaporator section of the air-handling unit (AHU) at the heart of the HVAC system, where evaporative cooling drives the heat exchange. Cold fluid (either chilled water or refrigerant) is circulated through coils in the evaporator section for the specific purpose of cooling air forced over the coils by a fan (see Figure 1.2).

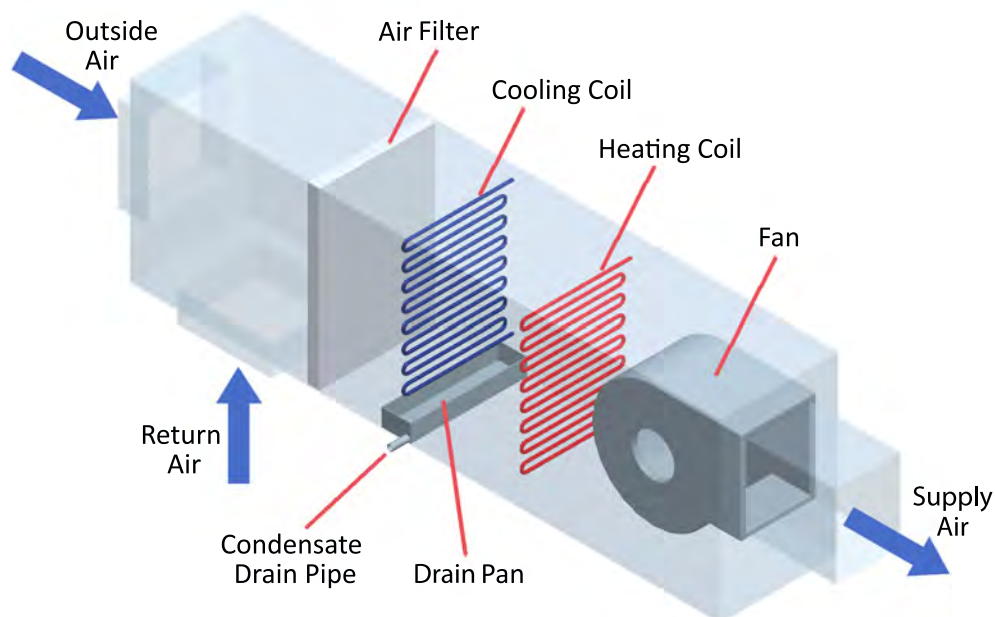

Figure 1.2 Schematic of a typical draw-through commercial air-handling unit (AHU)

The fan can either pull (draw) or push (blow) air over the coils, depending on the design of the unit. The vast majority of commercial AHUs draw air through the system, as illustrated in Figure 1.2. As air flows over the cooling coils (commonly known as evaporator coils), moisture from the air condenses on the cool surface of the coils and drips into a drain pan. Condensate is removed from the AHU through a drain port connected to the drain pan. Once the condensate exits the AHU through the drain port, it travels through a drainage line system to the point-of-use for an application or to a drain.

Condensate is an abundant source of reclaimed water. Using condensate and other on-site reclaimed water, such as rainwater, to offset the use of municipal water helps conserve water and lessen energy consumed by municipal water operations.

Applications of Condensate

The most effective use of condensate water collected from commercial or industrial buildings is for makeup water in cooling towers. This is because the pure and cool condensate water dilutes the sediment buildup in cooling towers (the sediment is left behind during the evaporative cooling process), increases the efficiency of the cooling towers by virtue of its relatively cool temperature, provides the most water in hot and humid conditions when makeup water for the cooling towers is most needed, and requires no additional storage or treatment. Condensate recovery ranges from 5% to 15% of required cooling tower makeup water (Guz 2005)¹ for typical commercial buildings and up to 45% for high-ventilation buildings such as laboratories (Sieber 2010).

Other common uses of condensate include toilet flushing, irrigation, ornamental water features, and process water, such as that used in manufacturing. Designing for these uses requires a water budget to determine how much water is produced (supplied) versus how much is required (demanded) for the intended purpose (see Chapter 7). Storage is required if the water produced cannot be immediately used for its intended purpose. This is the case with most applications except for cooling towers and perhaps some process water and irrigation applications, depending on exact needs.

Treatment in the form of filtration and disinfection is used to raise the quality of the water for its intended application (see Chapters 3-6). Applications in which reclaimed water could conceivably come in contact with human skin or be ingested require the highest-quality water. In all cases, a well-designed and well-maintained HVAC system is critical to the production of condensate that is free of microbial buildup or other contaminants (see Chapters 8, 9, and 11).

The best application, or combination of applications, for condensate use must be evaluated on a case-by-case basis, considering the factors outlined in this manual. The most important factors are codes/ordinances (Chapter 2), treatment (Chapters 4-6), storage (Chapter 9), water budget (Chapter 7), operations and maintenance (Chapter 11), and return on investment (Chapters 12 and 13).

Relevance of Condensate Collection in San Antonio

A city ordinance instituted in 2006 made San Antonio the first city in the United States to require all new commercial buildings (with greater than or equal to 10 tons of total cooling capacity) to design drain lines that capture condensate from air-conditioning systems and carry that water to a single on-site location (City of San Antonio 2009), [SAWCR§34.274.1]. The intent of the ordinance was to encourage building owners to use the condensate as a non-potable water source for applications such as cooling tower makeup water and irrigation. Using condensate helps alleviate the growing demand on limited water resources and the municipal water infrastructure. The fact

¹ One caution arises with district cooling where production of condensate can occur in an air-handling unit while the chiller and cooling tower rest idle (Lawrence 2010).

that San Antonio frequently experiences droughts makes condensate collection and use “an increasingly cost-effective and practical practice, especially since condensate quantity is the largest during the hot and humid months when water is most needed” (Guz 2005). Unfortunately, much of this usable water goes unused and is instead discharged to the sanitary drain, which unnecessarily taxes the municipal water system and is a missed opportunity for the metering and use of this pure water. This manual aims to increase condensate collection and reuse in San Antonio by facilitating the comprehensive evaluation, design, and implementation of condensate collection and use systems.

Reasons for Failure

The cause of failure for an on-site condensate collection system can originate anywhere from the design stage through operations and maintenance. For example, the system could be designed poorly, errors could be made during installation, or the system could incur problems over time due to normal wear or poor maintenance.

Commissioning is crucial to capture malfunctions before the system is put into service. In addition, scheduled inspections and maintenance are crucial to maintain continued effective operation of the system (see Chapter 11). Table 1.1 lists the top failure modes for on-site condensate collection and use systems.

Table 1.1 Top failure modes for on-site condensate collection and use systems

1	Storage tank too small or large. Incorrectly sized water storage tanks result in either wasted condensate or wasted initial investment in first cost of system. Consider combining condensate with other available on-site reclaimed water sources to optimize return on investment (see Chapter 9 and Chapter 12).
2	Unchecked water usage. Facility operators commonly use the water in the reclaimed system without discretion, believing the water is all or mostly reclaimed water (i.e., use it or lose it). However, since most reclaimed water systems include makeup water input from potable or recycled city water, a portion of the water is actually city water during times when condensate production does not keep up with water demand. Metering the amount of condensate and other sources of reclaimed water entering the system, along with the amount of city makeup water consumed by the system, provides the information needed to mitigate unintentional use of city water. This strategy is most useful when water is used for applications such as irrigation, whereby the quantity of water used can be adjusted based on available supply (see Chapter 9).
3	Improper or malfunctioning control system. Excessive use of city water provided as makeup water can stem from a poorly designed or malfunctioning control system. The typical culprits are the float switch, makeup water shut-off valve, drain valve, and/or control settings (see Chapter 9). The float switch triggers the makeup water shut-off valve to open, allowing makeup water from the city to fill the reclaimed water storage tank if the water falls below a predetermined critical level. The control system should be designed such that the makeup water is only used when absolutely necessary and not so much that when condensate does enter the tank it overflows and wastes water. Commissioning of the system before the system is put into service should catch control system design errors. Scheduled inspections will catch problems if they develop later (see Chapter 11).
4	Algae growth in storage tank. Algae can clog downstream pipes and components. It can also host illness-causing microbes such as <i>Legionella</i> . Opaque storage tanks prevent ambient sunlight from fueling algae growth. Properly treat water and test regularly (see Chapters 3-6).
5	Microbial growth in system. Microbial growth can occur anywhere between the HVAC drip pan and the point of use. The most common places are in the drip pan and in the storage tank. Microbes such as <i>Legionella</i> proliferate in warm stagnant water (see Chapters 3-6). Properly treat water and test regularly. Follow scheduled maintenance procedures to detect problems (See Chapter 11).
6	Malfunctioning HVAC drain seal. A malfunctioning drain seal results in reduced or stopped condensate flow. Check HVAC drip pan at least every 12 months (see Chapter 11). If the drain pan is not draining properly, check to see if the drain seal (see Chapter 9) is plugged by debris. Otherwise check for air leaks in the drain line between the drain pan and air-seal.

continued

Table 1.1 Top failure modes for on-site condensate collection and use systems (continued)

7	Leaks. Leaks equate to water loss. Comparing the amount of water supplied to the amount of water used will help determine if a leak is present. Installing meters on supply water lines and point-of-use outlets is the best way to monitor whether leaks occur over time. Measuring supply versus demand also enables water management (see Chapter 9). Performing an annual inspection to detect leaks is recommended (see Chapter 11).
8	Intent not met. Collecting HVAC condensate for on-site use helps conserve water. However, before designing a reclaimed water collection system, overall on-site water use should first be evaluated and reduced if possible. For example, replacing high water demand turf and vegetation with drought-resistant species, mulch, or permeable hardscape can drastically reduce on-site water demand and may even provide more water savings than installation of an on-site reclaimed water system. So if the goal is to reduce the use of municipal water, evaluate on-site water use before pursuing on-site reclaimed water systems. Taking both measures amplifies water savings.

References

- City of San Antonio. 2013. *San Antonio City Code*, Chapter 34, Article IV: Water Conservation and Reuse [SAWCR], per Ordinance 2013-02-07-0082.
- City of San Antonio. 2009. *Information Bulletin 163 on Condensate Collection - City Code 34-274.1* <<https://webapps1.sanantonio.gov/dsddocumentcentral/upload/IB163.pdf>> Accessed 20 July 2012.
- Guz, Karen. 2005. "Condensate Water Recovery." *ASHRAE Journal*, 47(6): 54-56.
- Lawrence, Tom, Jason Perry, and Peter Dempsy. 2010. "Capturing Condensate by Retrofitting AHUs." *ASHRAE Journal*, 52(1): 48-54.
- Sieber, Roy. 2010. "Alternate Sources of Water for Cooling Tower Make-Up." GovEnergy Conference. Dallas, TX, 15-18 August.

2

Codes and Standards

Codes, ordinances, and standards guide the design and implementation of water-conserving practices, with the goal of protecting human health and safety. Codes and ordinances are more regulatory in nature than standards and can be imposed by regulating entities at a national, regional, or municipality/local level. Standards, however, are enforceable if included in codes by direct reference.

International Codes and Standards

The International Plumbing Code (IPC) does not directly cover condensate water systems; rather, specific sections of the IPC are referenced for compliance in other codes, standards, and guidances. Although the International Green Construction Code (IGCC) and the International Association of Plumbing and Mechanical Officials' (IAPMO) Green Plumbing and Mechanical Code Supplement (GPMCS) specifically address air-conditioner condensate, neither of these have been adopted by the City of San Antonio. Therefore, requirements of the IGCC and GPMCS are considered as recommendations for best practices and are not legally binding in San Antonio.

Similarly, neither the American Society of Heating, Refrigerating, and Air Conditioning Engineers (ASHRAE) standards (i.e., Standards 189.1¹ and 191²) nor the National Sanitation Foundation (NSF) standards (i.e., Standards 350 and 350.1) have been adopted by the City of San Antonio. So these standards are also considered recommendations for best practices in San Antonio at this time.

It is important to note that the discrepancy in terms and definition between codes, standards, and guidances can be confusing. For example, the San Antonio Plumbing Code (SAPC) categorizes air-conditioner condensate as “reclaimed water,” whereas the IGCC categorizes condensate as “alternative on-site non-potable water.” For the purposes of this manual, the terms “reclaimed water” and “recycled water” will be used in a manner consistent with the definitions provided in the SAPC. The term “reclaimed water” is defined in the SAPC as “water from (on-site) sources such as rainwater harvesting, air-conditioning condensate collection, carwashes, ponds, lakes, rivers, or other sources as approved by the code official” [SAPC§10.25]. The term “recycled water” is defined in the SAPC as “water that, as a result of tertiary treatment of domestic wastewater by a public agency, is suitable for direct beneficial use or a controlled use that would not otherwise occur” [SAPC§10.25]. The categorization of air-conditioner condensate in the different codes and standards used as primary references in this manual are outlined in Table 2.1.

¹ ASHRAE Standard 189.1 is a compliance option of the IGCC and requires recovery of condensate for reuse in climates like San Antonio.

² Visit the ASHRAE website for current status of Standard 191 (www.ashrae.org).

Table 2.1 Categorization of air conditioner condensate and related terms in codes and standards

Code or Standard	Definitions, Categories and Terminology
San Antonio Plumbing Code (SAPC)	<p>Reclaimed Water. Water from (on-site) sources such as rainwater harvesting, <u>air-conditioning condensate collection</u>, carwashes, ponds, lakes, rivers or other sources as approved by the code official.</p> <p>Recycled Water. Water that, as a result of a tertiary treatment of domestic wastewater by a public agency, is suitable for direct beneficial use or a controlled use that would not otherwise occur. Also referred to as Municipal Reclaimed Water.</p>
Texas Administrative Code (TAC)	<p>Reclaimed Water. Wastewater that has been treated to quality for a suitable use, pursuant to the provisions of Chapter 210 of the TAC and other applicable rules and permits. Reclaimed water that is neither domestic nor municipal is sub-categorized as Industrial Reclaimed Water, which addresses <u>condensate from commercial air-conditioning units</u>.</p>
International Green Construction Code (IGCC)	<p>Captured condensate is explicitly included in the general category of Alternate On-site Non-potable Water. Condensate is implicitly included in the general category of (on-site) Reclaimed Water.</p> <p>Reclaimed Water. Non-potable water that has been derived from the treatment of wastewater by a facility or system licensed or permitted to produce water meeting the jurisdiction's water requirements for its intended uses. Also known as Recycled Water.</p> <p>Municipal Reclaimed Water. Reclaimed water treated by a municipality. The IGCC explicitly states that <u>air conditioner condensate</u> water is permitted to be collected for use by Graywater systems. The common practice of adding <u>air conditioner condensate</u> to a rainwater collection system is not specifically mentioned, although it is not prohibited.</p>
ASHRAE Standard 189.1	<p><u>Air conditioner condensate</u> falls under the definition of Alternative On-Site Sources of Water. The term "reclaimed water" is only used in the sense of Municipal Reclaimed Water.</p>
ASHRAE Standard 191	To be determined. Standard not yet released.
IAPMO Green Plumbing and Mechanical Code Supplement (GPMCS)	<p><u>Air conditioner condensate</u> falls in the general category of Alternative Water Sources, which are non-potable sources of water that include but not limited to graywater, on-site treated non-potable water, rainwater, and reclaimed (recycled) water. More specifically, <u>air conditioner condensate</u> falls in the sub-category of On-Site Treated Non-Potable Water.</p> <p>Reclaimed (Recycled) Water. Non-potable water provided by a water/wastewater utility that, as a result of treatment of domestic wastewater, meets the requirements of authority having jurisdiction for its intended use.</p>
NSF Standards 350 & 350.1	<p><u>Air conditioner condensate</u> falls under the general category of Wastewater. The term "reclaimed water" is only used in the sense of Municipal Reclaimed Water.</p>

Water reclamation and reuse governance in the United States is the responsibility of state and local agencies—there are no federal regulations for reuse. The primary two geographic-specific regulations addressing the on-site use of reclaimed water in San Antonio are the Texas Administrative Code (TAC) and the City of San Antonio Code, specifically Chapter 10, Article IX: Plumbing Code (SAPC), and Chapter 34, Article IV: Water Conservation and Reuse (SAWCR). The Texas Administrative Code, which governs the use of reclaimed water in Texas, defines reclaimed water as “wastewater which has been treated to quality for a suitable use” and defines reclaimed water that is neither domestic nor municipal as “industrial reclaimed water” [TAC§210.2, TAC§210.52]. Condensate from commercial air-conditioning units falls in the category of industrial reclaimed water, as defined by the TAC. The use of the term “reclaimed water” in the TAC to describe condensate is consistent with the SAPC and SAWCR. The TAC defines two levels of industrial reclaimed water: Level I and Level II.

Texas Administrative Code

TAC Level I

Industrial reclaimed water must satisfy three criteria to qualify for TAC Level I authorization: the water must come from one of the sources listed in Table 2.2, be used for one of the applications listed in Table 2.3, and have a primary means of disposal during times when it is not used for the intended application [TAC§210.53]. Acceptable primary means of disposal are one or more of the following: authority to route to a publicly owned treatment works (POTW), authority to discharge under a permit (issued by TCEQ), or arrangements to haul away (typically through a contractor) [TAC§210.56].

Table 2.2 Industrial reclaimed water sources eligible for Level I authorized use [TAC§210.53]

1	Condensate from air conditioner, compressor, steam, steam line surface
2	Washwater from washing whole fruits and vegetables
3	Cooling water; either once-through or non-contact
4	Backwash from treatment filter
5	Water from routine external washing of buildings, conducted without the use of detergents or other chemicals
6	Water from routine washing of pavements, conducted without the use of detergents or other chemicals and where spills or leaks of toxic or hazardous waste have not occurred (unless spilled material has been removed)
7	Cooling tower blowdown with total dissolved solids concentration less than 2,000 milligrams per liter
8	Other wastewater adhering to requirements outlined in TAC§210.53(a)(9)

Table 2.3 Industrial reclaimed water uses compatible with Level I water authorization [TAC§210.56]

1	Irrigation, including landscape irrigation
2	Fire protection
3	Dust suppression and soil compaction
4	Maintenance of impoundments
5	Irrigation of non-food crops
6	Irrigation of pastures for milking animals

If these three criteria are met and a water sample test demonstrates that the water does not exceed the maximum allowable levels (MAL) of contaminants (see Appendix A), the industrial producer is authorized to use the Level I industrial reclaimed water on-site without notification or approval by the Executive Director of TAC [TAC§210.55]. Subsequent effluent sampling is not required for water from sources 1-7 in Table 2.2, with the exception of cooling tower blowdown, which must be monitored to ensure the 2,000 milligrams per liter threshold level for total dissolved solids is maintained over time [TAC§210.55]. The system owner should be prepared to provide proof that water quality meets the requirements for Level I coverage if requested by a Texas Commission on Environmental Quality (TCEQ) inspector. It is the responsibility of the system owner to ensure that the water quality is maintained to safely satisfy the intended purpose.

Internal recycling systems, closed loop systems, and systems that use industrial wastewater as makeup water within a facility are not subject to the special requirements governing the use of industrial reclaimed water and as such also do not require authorization or sampling by the TAC [TAC§210.51]. These three types of systems exist in areas of the facility where the risk of cross-

connection with potable water is minimal. Condensate used as makeup water for a cooling tower, for example, falls in this exempt group; toilet flushing does not.

TAC Level II

Some industrial waste water is explicitly not authorized for reuse regardless of effluent quality or end use, due to potential hazards, as dictated by TAC§210.54. For all other industrial waste water that does not meet the three criteria for TAC Level I authorization and is not classified as used in an internal recycling system, a closed loop system, or a system that uses industrial wastewater as makeup water within the facility, a producer is eligible to apply for Level II authorization for any of the reasons listed in Table 2.4. A formal application for authorization must be submitted to the Executive Director of the TAC. The Executive Director can impose additional limits on the water if needed to ensure that no harm is done due to human contact.

Table 2.4 Eligible reasons to apply for Level II authorization for industrial reclaimed water [TAC§210.53]

1	Reclaimed water contains pollutant concentration levels that exceed threshold levels (Appendix A), but the pollutant is not a listed waste in TAC§210.54
2	Reclaimed water contains any amount of domestic wastewater
3	Proposed end use of reclaimed water is not on-site
4	Proposed end use is not listed in Table 2.3
5	Disposal method proposed as alternative to reuse does not satisfy any of the following conditions: is authorized discharge water under a permit, is authorized to route to a publicly owned treatment works (POTW), or is recycled in a manner that does not discharge into or adjacent to water in the state

Level II authorizations require monitoring and must comply with limits outlined in Table 2.5 and any others requested by the Executive Director of the TAC. The reclaimed water must be grab sampled (i.e., a single sample at a specified time) after final treatment, if any, but before distribution to point-of-use [TAC§210.57]. If industrial reclaimed water is used less frequently than the sampling rates specified in Table 2.5, then samples can be obtained during times of use [TAC§210.56]. Analytical methods must comply with Chapter 319 of the TAC and records must be maintained for at least five years [TAC§210.57]. Maintaining a sampling record using a template similar to that in Appendix B is a recommended good practice for all reclaimed water systems, even if reporting to the TAC is not required.

Table 2.5 Level II limits and monitoring requirements [TAC§210.56]

Level II Limits	Sampling Method
Total organic carbon less than or equal to 55 mg/l	Grab sample once a month
pH minimum of 6.0 su and maximum of 9.0 su	Grab sample once per week

The owner of any facility within the service area of a publicly owned treatment works (e.g., SAWS) must provide notice to the publicly owned treatment works of intent to use industrial wastewater [TAC§210.56].

Commingling of rainwater with TAC Level I and Level II water

Although rainwater is not mentioned in the TAC list of industrial water sources for reclamation, commingling of rainwater with any of the Level I or Level II authorized industrial reclaimed

sources is treated the same way as for industrial wastewater. As such, to be eligible for Level I use, the commingled water must satisfy the contaminant limits for industrial wastewater listed in Appendix A. Otherwise the commingled water is automatically considered for Level II use.

Level I and Level II versus Type I and Type II

Level I and Level II are not to be confused with Type I and Type II water. The “Type” identifies the expected human exposure for the water application. For Type I use of water, human contact is likely. Examples of Type I use of reclaimed water include irrigation, recreational water impounds, fire suppression, and toilet flushing (TAC). For Type II use of water, contact with humans is unlikely, such as use in restricted or remote areas (TAC).

City of San Antonio Codes and Ordinances

Reclaimed water systems residing in the City of San Antonio must comply with the City of San Antonio Plumbing Code (SAPC). San Antonio adopted the International Plumbing Code (IPC) with amendments to create the Plumbing Code of the City of San Antonio for Non-Residential Buildings. Non-residential buildings include commercial buildings, which are the focus of this manual.

Table 2.6 lists the approved applications for non-residential reclaimed condensate water in San Antonio [SAPC§1304.1]. Other common applications such as cooling tower makeup water, water features, fire suppression, and car washing, as well as newly proposed uses must adhere to TAC requirements and be approved by the San Antonio code official. The San Antonio code official for reclaimed water systems is the Director of the Development Services Department (DSD) or a duly authorized representative to act on his or her behalf. The duly authorized representative is typically a plumbing inspector in the Building Development Division of DSD.

Table 2.6 Non-residential reclaimed/recycled water applications approved by the City of San Antonio

1	Toilet and urinal flushing
2	Trap primers for floor drains and floor sinks
3	Subsurface irrigation

Per the San Antonio City Code (SACC), condensate is not permitted to drain into a storm sewer, roof drain overflow piping, system public way, or impervious surface [SAWCR§34.274.1]. Therefore, in San Antonio, when condensate is not used on-site, it is discharged to the sanitary drain.

The SACC requires that all owners of non-residential non-potable water tanks with over a 500 gallon capacity register their tanks with the SAWS Conservation Department prior to the start of operation of the attached non-potable water system [SAWCR§34.273.12]. In addition, all non-residential water features must be metered separately or sub-metered [SAWCR§34.273.13]. Code requirements addressing labeling and signage are outlined in a separate chapter (see Chapter 10).

International Green Construction Code

The International Green Construction Code (IGCC) is not currently required in San Antonio. Therefore, the IGCC requirements are considered as best practices in San Antonio at this time. Unlike the TAC and SAPC, which list allowable applications of reclaimed condensate water, the IGCC mandates the use of alternate on-site non-potable water when available and allowable by the authority having jurisdiction.

The IGCC requires that condensate be collected and reused on-site for applications such as, but not limited to: water features, fountains, graywater collection systems, and rainwater collection systems [IGCC§703.4], unless on-site applications are not available.

The IGCC mandates the use of alternative on-site non-potable water, where available and approved, for outdoor ornamental fountains and water features [IGCC§404.2]. Furthermore, a potable makeup water connection is prohibited if the fountain or water feature is the primary user of the building site's non-potable water source [IGCC§404.2]. An exception is made (i.e., permission is granted to use potable water) if the following conditions are met: the water is recirculated, the potable water connection is not controlled by an automatic refill valve, the catch basin or reservoir is no greater than 100 gallons, and the exposed water surface area is less than 20 square feet. Note that ornamental fountains and water features are required to recirculate and reuse water [IGCC§404.2.2], so the first condition is automatically met if following the IGCC requirements.

Although not specifically required by the IGCC, the use of alternative on-site non-potable water, such as condensate, can help meet the IGCC irrigation requirement to reduce potable water use for outdoor landscape irrigation by 50% from a calculated mid-summer baseline [IGCC§404.1.1]. This reduction is typically achieved by landscape design, the use of alternative on-site non-potable water, or both of these.

Potable water is not permitted to be used to prime traps when an alternative non-potable on-site water, reclaimed water, or graywater distribution system is available [IGCC§702.9]. Likewise, wet-hood exhaust scrubbers must use alternative non-potable on-site water or municipal reclaimed water of appropriate quality for application, if available, rather than potable water [IGCC§703.8.2]. Furthermore, when municipal reclaimed water is not greater than 150% of the distance that the potable water supply is from the lot boundary, or the municipal reclaimed water supply is within 100 feet of potable water supply that serves the lot, municipal reclaimed water must be used, when permitted by jurisdiction having authority, for water closets, water-supplied urinals, water-supplied primers, and applicable industrial uses [IGCC§702.7].

On-site reclaimed water treatment systems used to produce non-potable water for use in water closets and urinal flushing, surface irrigation, and similar applications must be listed and labeled according to the National Sanitation Foundation (NSF) Standard 350 [IGCC§704.3].

In terms of monitoring, the GPMCS and IGCC water quality requirements for rainwater are relevant when condensate is commingled with rainwater. The GPMCS imposes a quality threshold for rainwater of *E. coli* less than 100 CFU/100 ml and turbidity less than 10 NTU for common urban reclaimed water applications such as water features and cooling tower makeup water [GPMCS§505.9.4]. The International Green Construction Code (IGCC) imposes quality thresholds for rainwater of pH between 6-7, BOD 10 mg/l, NTU ≤ 2 , no detectable fecal coliform/100 ml, no detectable chlorine in 100 ml, and no detectable enteroviruses/100 ml [IGCC§707.12.10].

Watering Restrictions Imposed by San Antonio Water System

Drought restrictions and related variances can influence a building owner's choice of application for reclaimed condensate water. For example, in times of drought, San Antonio Water System (SAWS) prohibits the use of fountains, waterfalls, or other aesthetic water features³ unless a variance has been granted. SAWS can approve a basic variance for water features confirmed by SAWS to be in good working order and using 100% recycled, reuse, reclaimed graywater, condensate, or cooling tower blowdown or other on-site reclaimed water [SAWCR§34.332]. So, if a water fountain is an important feature to a building owner, then the owner may choose to route condensate to the fountain so the fountain is permitted to operate during times of drought.

³ All indoor water features in good working order are exempt.

Likewise, since landscape watering is limited in times of drought, the building owner could choose to design the condensate or on-site reclaimed water system to irrigate landscaping and apply for a variance to the drought restriction for landscape irrigation. See Chapter 34, Article IV. *Water Conservation and Reuse* in the San Antonio City Code for further details on drought restrictions and variances in San Antonio [SAWCR§34.271-34.425].

Permits Required in the City of San Antonio

A plumbing permit issued by the San Antonio code official is required to erect, install, enlarge, alter, repair, remove, convert, or replace a reclaimed/recycled water system [SAPC§1304.2]. Permits typically require the submission of construction documents, engineering calculations, diagrams, and other pertinent information. The reclaimed water system must pass an inspection by both the San Antonio code official and a SAWS official before operation of the system is permitted.

References

- American Society of Heating, Refrigerating, and Air-Conditioning Engineers. Pending publication. *ASHRAE Standard 191: Efficient Use of Water in Building Site and Mechanical Systems*. Atlanta, GA.
- City of San Antonio. 2011. *San Antonio City Code*, Chapter 10, Article IX: Plumbing Code [SAPC], per Ordinance 2011-12-01-0984.
- City of San Antonio. 2013. *San Antonio City Code*, Chapter 34, Article IV: Water Conservation and Reuse [SAWCR], per Ordinance 2013-02-07-0082.
- International Association of Plumbing and Mechanical Officials. 2012. *2012 Green Plumbing and Mechanical Code Supplement [GPMCS]*.
- International Code Council. 2011. *2012 International Plumbing Code [IPC]*.
- International Code Council. 2011. *2012 International Building Code [IBC]*.
- International Code Council. 2012. *2012 International Green Construction Code [IGCC]*.
- National Sanitation Foundation. 2011. *NSF/ANSI Standard 350: Onsite Residential and Commercial Water Reuse Treatment Systems*. Ann Arbor, MI.
- Texas Commission on Environmental Quality. *Texas Administrative Code [TAC]*, Title 30, Chapter 210. < www.sos.state.tx.us/tac/ > Accessed 20 July 2012.

3

Condensate Water Contaminants

Condensate is generated in the same manner as distilled water, which has a slightly acidic pH value around 5.8, as compared to a neutral pH value of 7.0, and contains no minerals (Buzzle 2013). However, unlike distilled water, condensate is subject to environmental contamination during the process of collection and transport. Microorganisms (e.g., bacteria and viruses) suspended in air drawn from inside and/or outside the building (i.e., return air and/or outside air) through the Air Handling Unit (AHU) can collect on the cooling coils with the moisture when condensate is formed (see Chapter 1 for a schematic of an AHU). In addition, being slightly acidic, condensate tends to react with materials with which it comes in contact. Such reactions can raise the pH value of condensate. Any molecules or particulates the condensate picks up during formation or along its flow path can be referred to as a contaminant and must be considered when making treatment decisions. A certified third-party lab can be hired to test the water for contaminants—organic, inorganic, and biological. A list of nationally certified testing laboratories can be found on the Environmental Protection Agency (EPA) website and those specifically in Texas can be found on the Texas Commission on Environmental Quality (TCEQ) website (Environmental Protection Agency 2012a, Texas Commission on Environmental Quality 2012).

As shown in Table 3.1, of the alternative water sources that are commonly available for collection and on-site use, condensate from AHUs and rainwater demonstrate the highest water quality. So a relatively low level of contaminants is expected to be found in condensate.

Metals

The condensate contacts metals along the flow path such as cooling coils, drain pans, pipes, valves, meters, tanks, and other appurtenances. The acidic nature of the condensate prompts reactions with metals, especially iron and steel, to form metal ions (Alliance for Water Efficiency 2012). In the vast majority of cases, the trace concentration of metals in the condensate is inconsequential.

However, under limited circumstances, the metals can accumulate to toxic levels. For example, metals could be a concern when using condensate piped through metal pipes for irrigation, since metals could build up in the soil to a toxic level over a long period of time. If the chosen application is sensitive to metals, design the system to minimize the exposure of condensate to bare metal components along the condensate flow path. Alternatively, treat and test the water as appropriate. Other inorganic constituents besides metals, such as salts, oxyhalides, and nutrients, are not expected to be present in condensate, but must be considered if condensate is commingled with other reclaimed water sources. When cleaning the AHU cooling coils, divert the wastewater to an appropriate disposal path to prevent excess metals (e.g., copper from the cooling coils), dirt, microorganisms, and cleaning solvents from contaminating the reclaimed water.

Table 3.1 Water quality considerations for on-site alternative water sources (Source: EPA 2012b)^a

Possible Sources	Level of Water Quality Concern					
	Sediment	Total Dissolved Solids (TDS)	Hardness	Organic Biological Oxygen Demand (BOD)	Pathogens ^b	Other Considerations
Rainwater	Low/Medium	Low	Low	Low	Low	None
Stormwater	High	Depends	Low	Medium	Medium	Pesticides and fertilizers
Air Handling Condensate	Low	Low	Low	Low	Medium	May contain copper when coil cleaned
Cooling Tower Blowdown	Medium	High	High	Medium	Medium	Cooling tower treatment chemicals
Reverse Osmosis and Nanofiltration Reject Water	Low	High	High	Low	Low	High salt content
Graywater	High	Medium	Medium	High	High	Detergents and bleach
Foundation Drain Water	Low	Depends	Depends	Medium	Medium	Similar to stormwater

^a The use of single-pass cooling water is also a possible source of clean on-site water, but facility managers should first consider eliminating single-pass cooling because of its major water-wasting potential. For that reason, it is not included in the list.

^b Disinfection for pathogens is recommended for all water used indoors for toilet flushing or other uses.

Pathogenic Microorganisms

Condensate collection occurs in a process that is open to contamination from the surrounding environment. Design and engineering should be applied to both new and existing systems to limit the amount of contamination that may occur during the generation and collection of the condensate. The pathogenic microorganism most likely to contaminate condensate collection systems is the bacterium *Legionella*. *Legionella* can cause respiratory infection, also called Legionnaire's disease, when inhaled. *Legionella* can be carried in aerosol form into the AHU or storage tank. Without proper treatment *Legionella* proliferates in warm water, such as in water storage tanks. Creating an aerosol from infected water in applications such as sprinkler irrigation systems and cooling towers increases the risk of inhalation of *Legionella*. For this reason, as a precaution, above-ground irrigation with reclaimed/recycled water is often prohibited, and setbacks from public areas are recommended for cooling towers.

The main parameter driving *Legionella* colonization in condensate collection system is the amount of organic material present. The less organic content present, the lower the levels of biofilm formation and microbial contamination that will occur. Water from multiple on-site water sources is often stored in a common tank to optimize the storage capacity of on-site reclaimed water systems. These other sources, such as rainwater and particularly graywater, not only introduce additional microorganisms, but also increase the organic content and formation of biofilms, thereby increasing the likelihood of contamination by microorganisms, including *Legionella*. Treatment processes should be in place to prevent biofilm formation within transport piping and storage tanks.

Organic content is generally undesirable in water because it provides food for microorganisms, consumes oxygen, and interferes with disinfection. Aggregate measures of organic matter include: total organic carbon (TOC), dissolved organic carbon (DOC), particulate organic carbon (POC), biochemical oxygen demand (BOD), and chemical oxygen demand (COD) as outlined in the *EPA 2012 Guidelines for Water Reuse* (Environmental Protection Agency 2012c).

When water from different sources is combined in a storage tank, the commingled water in the tank must be treated to account for contaminants in all water sources included in the mix and must meet the minimum water quality requirements established for the application by the laws, rules, and ordinances applicable in the jurisdiction [IGCC§706.3]. Since rainwater can carry traces of fecal matter from the rainwater collection surface into a common storage tank, the large variety of pathogenic microorganisms originating in the fecal matter of animals must be considered in water treatment when rainwater is harvested. Appendix C contains a list of common pathogenic microorganisms found in rainwater, most of which originate from fecal matter.

This document does not address the treatment required when reclaimed water (e.g., condensate and rainwater) is mixed with graywater, such as wastewater from bathtubs, showers, lavatories, and clothes washers. Graywater sources may require additional monitoring and treatment and are primarily different in nature because the organic content (contaminant) varies according to what is washed and what detergents are used.

Algae

Algae can clog water filters, pumps, and valves. Algae can also harbor pathogenic microorganisms and provide nutrients for their growth. Unlike high doses of UV light used to disinfect water, ambient UV light promotes algae growth in stagnant water. Therefore, in addition to proper water treatment, protect the flow path from ambient light. This can be accomplished using opaque water storage tanks and piping. Alternatively, tanks can be located in shade structures. Protecting materials such as PVC from UV light also prevents UV degradation of the material.

Byproducts of Treatment

The treatment methods themselves can form unintended byproducts that may pose health risks, so more treatment is not necessarily better. There is an optimal treatment range that keeps both pathogens and byproducts below maximum allowable levels. The four byproduct categories regulated by the EPA for drinking water are total trihalomethanes, haloacetic acids (HAAS), chlorite, and bromate. The EPA provides a comprehensive list of allowable maximum contaminant levels (MCL) of these contaminants as well as all regulated drinking water contaminants (Environmental Protection Agency 2009). A comprehensive discussion of byproducts is provided in the *Alternative Disinfectants and Oxidants Guidance Manual* published by the EPA (Environmental Protection Agency 1999). The EPA limits for drinking water can be used as a reference for non-potable applications of reclaimed water, especially when human contact with the reclaimed water is expected.

References

- Alliance for Water Efficiency. "Condensate Water Introduction." <www.allianceforwaterefficiency.org/Condensate_Water_Introduction.aspx> Accessed 27 August 2012.
- Buzzle. "Distilled Water pH Level." <www.buzzle.com/articles/distilled-water-ph-level.html> Accessed 14 March 2013.
- Environmental Protection Agency. 1999. *Alternative Disinfectants and Oxidants Guidance Manual*. EPA 815-R-99-014. Washington, DC.

Environmental Protection Agency. 2009. *National Primary Drinking Water Regulations*. EPA 816-F-09-0004. Washington, DC.

Environmental Protection Agency. "Laboratory Certification Program."
<<http://water.epa.gov/scitech/drinkingwater/labcert/index.cfm>> Accessed 27 August 2012a.

Environmental Protection Agency. 2012b. *Water Sense at Work: Best Management Practices for Commercial and Institutional Facilities*. EPA 832-F-12-034. Washington, DC.

Environmental Protection Agency. 2012c. *2012 Guidelines for Water Reuse*. EPA 600-R-12-618. Washington, DC.

International Code Council. 2012. *2012 International Green Construction Code [IGCC]*.

Texas Commission on Environmental Quality. "Public Drinking Water Laboratory Certification."
<www.tceq.texas.gov/field/qa/drinking_water_certification.html> Accessed 27 August 2012.

4

Water Treatment Methods

In 1866, before water was treated, infected drinking water caused a severe cholera epidemic in San Antonio (Burns 2013). This epidemic spurred efforts to establish a safe water supply system for the city, which has evolved over the years into the San Antonio Water System (SAWS). The prolonged successful treatment and distribution of safe water in developed countries like the United States makes water-related illness seem like a matter of the past.

However, establishing safe water is not a trivial matter. With water conservation efforts pushing the envelope of on-site water collection and use toward potable water applications, more guidance, codes, and standards are needed to address the risks associated with waterborne illness in on-site systems. Individuals accepting the responsibility for treating their own water on-site must take the same precautions as SAWS in treating and regularly testing their water. Otherwise, individuals risk infection from waterborne contaminants indicative of improperly maintained water supplies.

Treatment Train

The required treatment of reclaimed condensate water for each building will depend on the ultimate use of the water. For example, the use of reclaimed condensate water as a non-potable supplemental source for cooling towers will likely not require any additional treatment. On the other hand, extensive treatment with specialized equipment will be required for condensate water used as a potable water source (Munters Corporation 2013). Ensuring that the reclaimed water system produces water quality adequate for the intended use is the joint responsibility of the designer and installer (see Chapters 5 and 6). Maintaining this quality is the responsibility of the building owner through effective operation and maintenance of the system (see Chapter 11).

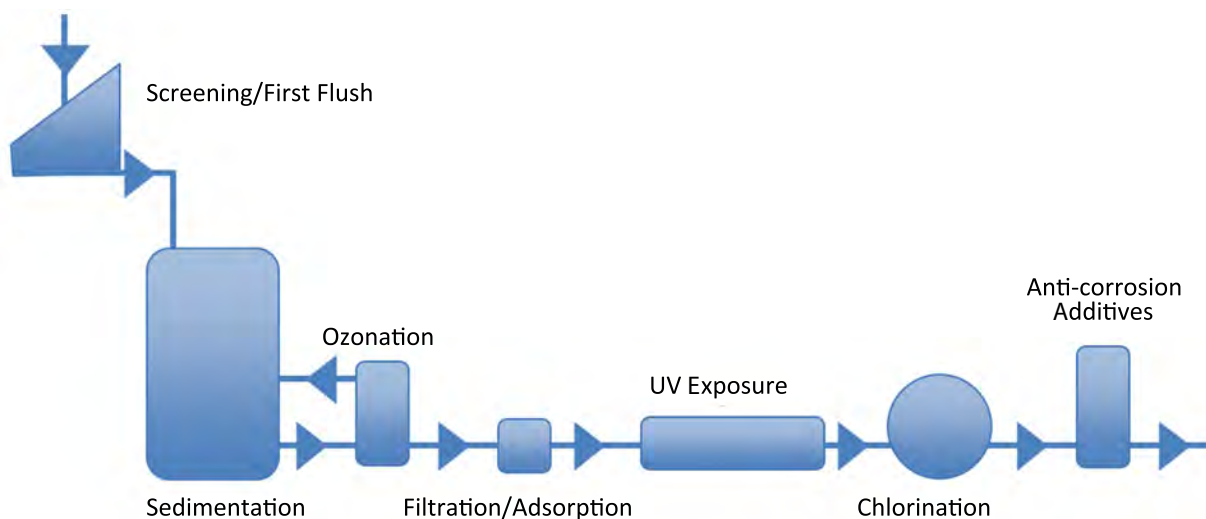

Figure 4.1 Schematic of a water treatment train including all traditional treatment methods (Source: adapted from Mechell et al. 2010 with permission from © Texas A&M Agrilife Extension Service)

The most common water treatment methods to remove unwanted contaminants from on-site reclaimed water are screening, sedimentation, mechanical filtration, UV sterilization, adsorption, chlorination, ozonation, and reverse osmosis. Often treatment methods are combined to satisfy particular uses of the water. When combined, the treatment methods are instituted in a prescribed sequence to complement one another. This sequence is called a treatment train. A treatment train that includes all traditional water treatment methods for on-site reclaimed water is shown in Figure 4.1. Advanced oxidation processes (OAPs) can be added at the end of a treatment train for higher levels of purification.

The actual treatment train for a specific site will include only the subset of methods from Figure 4.1 that are appropriate for the sources of reclaimed water present and the quality required for its intended use. This concept of only treating water to the purification level necessary is referred to as “Fit for Purpose” and keeps treatment costs to a minimum (Environmental Protection Agency 2012). A qualified professional must design the treatment train on a case-by-case basis. Factors considered when evaluating treatment alternatives include disinfection effectiveness and reliability, capital costs, operation and maintenance costs, practicality, and potential adverse affects (e.g., formation of toxic byproduct with chemical treatments).

Screening

Screening removes large debris such as leaves and twigs. Screening is commonly used in rainwater harvesting to eliminate debris before water enters a first flush device or is delivered to a storage tank.

First Flush

The first flush device diverts a predetermined volume of rainwater collected from a surface, such as a roof, at the beginning of a rain. This prevents the water containing the highest concentration of contaminants from the rooftop, such as pollen and fecal matter from birds and rodents, from entering the water storage tank. A first flush device is not necessary in the condensate water flow path.

Sedimentation

Allowing particulate to fall naturally to the bottom of a storage tank is a viable means of separating that particulate from the usable water, as long as water removed from the storage tank is extracted from a level well above the sediment. For this reason, the International Green Construction Code (IGCC) requires that the water outlet in the water storage tank be at least 4 inches above the bottom of the tank [IGCC§707.11.7.8]. Likewise, the IGCC requires the inlets to a storage tank be designed to introduce minimal turbulence and avoid agitation of tank contents, which would stir up sediment [IGCC§707.11.7.7]. Sediment can be cleaned out of the tank as needed during routine maintenance. Similarly, the outlet must not skim water from the surface because a biofilm commonly forms at the top surface of water stored in a tank, along with particulate that floats.

Mechanical Filtration

Mechanical filtration removes various particles from the water based on the pore size of the filter. Filters with small enough pores can remove microorganisms from water. Microfilters are important for this reason, to remove parasites such as *Giardia*. Figure 4.2 shows the common classifications of filters related to particle size. Reclaimed water is often routed through multiple filters of decreasing pore size.

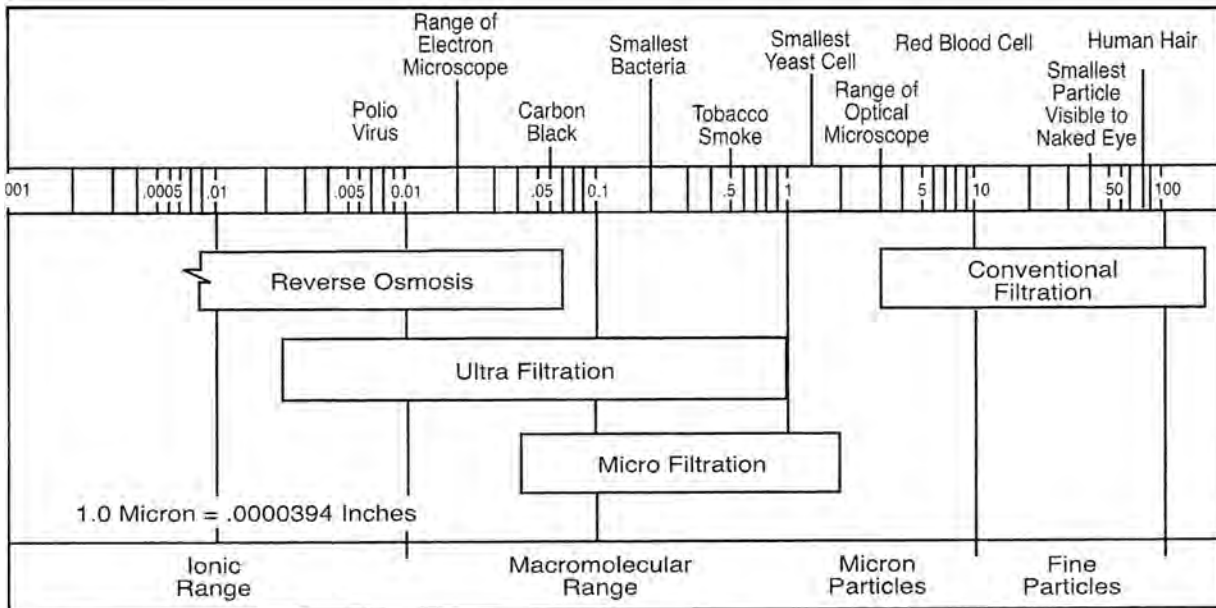

Figure 4.2 Particle size separation comparison chart (Source: Environmental Protection Agency 2004)

Filters are placed before UV disinfection because filtration clarifies the water, making UV disinfection more effective. Filters are also placed after other treatment processes, such as coagulation, to collect precipitates from those processes. Mechanical filters require regular maintenance and replacement to function properly. Pressure gauges are typically installed in the proximity of filters to indicate when a filter is loaded with particulate and requires servicing. See manufacturer specifications and claims for each individual filter type (Mechell et al. 2010).

Carbon Adsorption

Active carbon is a common adsorptive material used in filters to attract substances such as organic and volatile organic chemicals (VOCs). Carbon adsorption treatment can also remove metal ions (Environmental Protection Agency 2004). The adsorption process takes time, so water speed through the filter is a design consideration.

Densely packed carbon filters can also act as mechanical filtration systems. Active carbon filters are placed upstream of the chlorinator and UV system. Activated carbon filters must be maintained or replaced regularly. See manufacturer specifications for individual filter performance. (Mechell et al. 2010).

Screening, diversion of first flush, sedimentation, mechanical filtration, and carbon adsorption are all effective methods for controlling the levels of organic compounds present in reclaimed condensate. Effective design and use of these treatments will reduce the demand on the more expensive treatment options, such as chlorination, ozonation, UV exposure, hydroxyl radical treatment, and reverse osmosis. Again, the level of treatment will depend on the ultimate use of the reclaimed condensate.

Ozonation

Ozone (O_3) is a powerful disinfecting agent and chemical oxidant in both inorganic and organic reactions and destroys bacteria and viruses in a matter of minutes (Environmental Protection Agency 2004). Ozone can also reduce concentration of manganese, sulfide, and iron and reduce

or eliminate taste and odor problems (Environmental Protection Agency 1999). Filters can be implemented downstream of ozonation to remove oxidized solids from the water. Ozone can reduce some VOCs.

Ozone is an inherently unstable molecule. The residual time of dissolved ozone in water is on the order of 5-10 minutes (Environmental Protection Agency 1999). Ozone exposed to air will naturally decay back into oxygen within 20 to 40 minutes after generation (Taylor 1995). Therefore, ozone has a powerful immediate disinfecting effect, but does not have a lasting effect in water (Environmental Protection Agency 2004). Service providers who operate and maintain ozone systems must undergo safety training from ozone equipment manufacturers due to ozone's toxic nature in high concentrations. Ozone produces bromate and bromoform byproducts, both of which might adversely affect human health (Environmental Protection Agency 1999). Ozone is also very corrosive, so materials are a consideration in selecting system components.

Ultraviolet Light

Ultraviolet (UV) light disinfects microorganisms by exposing them to short-wavelength ultraviolet radiation of much greater intensity than sunlight. Particles larger than 10 microns in size can shield microorganisms from disinfection by UV light. Smaller particles do not shield organisms but do reduce UV transmittance (Environmental Protection Agency 2012). Most ultraviolet purification systems are combined with mechanical filtration (pore size ≤ 5 micron) upstream of the UV disinfectant to remove particulate that would otherwise interfere with the effectiveness of the UV treatment. A UV light intensity monitor is commonly installed to warn maintenance personnel if the filter ceases to effectively capture particles, resulting in unacceptable turbidity. UV sterilizers are easy and cost effective to install and maintain and are more effective than chlorine against the microorganisms *Cryptosporidium* and *Giardia* (Environmental Protection Agency 2012). UV light has an immediate disinfecting effect, but does not have a lasting effect in water. Therefore, UV and chlorination are commonly used in combination to leverage the ubiquitous disinfection of UV and the lasting effect of chlorine.

Use only ANSI/NSF Standard 55 (Class A) certified UV devices (Mechell et al. 2010). See manufacturer's specifications for expected lifespan of the UV device's lamp. Since life spans are typically around 12 month, it is a common practice to replace the UV lamp during scheduled annual maintenance. Advancements in UV systems such as low pressure high output (LPHO) and microwave-generated UV enable lower-cost UV systems (Environmental Protection Agency 2012). Additional information on UV light disinfection can be found in the *2012 Ultraviolet Disinfection Guidelines for Drinking Water and Water Reuse*.

Chlorination

Chlorine is a simple and cost-effective chemical treatment for destroying pathogenic microorganisms. Water pH, water temperature, concentration and form of chlorine, degree of mixing, time of contact, and presence of interfering substances impact the efficiency of chlorine treatment. Under common reclaimed water conditions, standard doses of chlorine (up to 5 ppm) require on the order of an hour of contact time to destroy microorganisms (Soderholm 2012). Therefore, simply injecting a small dose of chlorine before water is transported to its intended application is not adequate.

Chlorine dioxide is more reactive than sodium hypochlorite (i.e., quicker to disinfect and effective on algae, cysts, etc.) and is becoming more and more popular for *Legionella* abatement in domestic water systems, such as those in hospitals (Soderholm 2012). Time-release chlorine tablets can be placed in the condensate drain pan to help prevent microbial growth in the drain pan and drain seal system. Chlorine can also be added to water stored in a tank or injected in measured

doses into water traveling through a pipe. Chlorine continues to disinfect the water for a span of time, up to days after it is introduced to the water, even as the water travels downstream through the water distribution system. A closed system with minimal air vents helps trap the chlorine and prolong the residual effect.

“In general, bacteria are less resistant to chlorine than viruses, which in turn, are less resistant than parasite ova and cysts” (Environmental Protection Agency 2012). In fact, *Giardia lamblia* and *Cryptosporidium parvum* and *hominis*, which exist in the environment as cysts or oocysts, have been found in reclaimed water effluents, the majority of which utilized chlorination (Environmental Protection Agency 2012). Therefore, it is more and more common to find chlorine disinfectant combined with UV light disinfection, since UV light renders *Giardia* and *Cryptosporidium* inactive. In cases where condensate is mixed with rainwater, organic constituents from the rainwater act to consume the chlorine while particulate matter from the rainwater protects microorganisms from inactivation by the disinfectant, making disinfection more challenging for condensate mixed with rainwater as compared to condensate alone.

Avoid products with UV stabilizers, such as those used for pools, and fragrances. Use only chlorine products certified in accordance with ANSI/NSF standard 60 requirements (Mechell et al. 2010). Be aware that chlorine can degrade some materials over time. Therefore choose chlorine resistant materials for reclaimed water plumbing when possible (e.g., cross-linked Polyethylene (PEX) type B tubing is less susceptible to chlorine than PEX type A tubing)

Chlorine produces chlorinated hydrocarbon byproducts such as trihalomethanes (THMs) as well as other byproducts (Environmental Protection Agency 1999). Chlorine can also kill grass and shrubbery when reclaimed water is used for irrigation. Ferrate, which was explored as a chemical replacement for chlorine in the 1970s, is a potentially competitive oxidizing agent for the disinfection of water (Environmental Protection Agency 2012).

Pasteurization

Pasteurization, which uses heat to inactivate pathogenic or spoilage microorganisms, can be used for water purification in situations where waste heat is available (e.g., turbines, digester gas, or hot water) (Environmental Protection Agency 2012).

Advanced Oxidation Process

Advanced oxidation processes (AOPs) used in water treatment include UV/H₂O₂, ozone/H₂O₂, ozone/UV, UV/TiO₂, and a variety of Fenton reactions such as Fe/H₂O₂, Fe/ozone, and Fe/H₂O₂/UV (Environmental Protection Agency 2012). AOPs are added to the end of a treatment train to achieve high levels of disinfection. For example, the UV/H₂O₂ approach, also known as hydroxyl radical treatment (HRT), executes a measured hydrogen peroxide (H₂O₂) injection followed by exposure to shortwave UV radiation from a UV lamp. This process frees a certain percentage of hydroxyl radicals (OH molecules), which are extremely reactive and quick to kill microorganisms (Environmental Protection Agency 1999). HRT can also remove some metals and VOCs, depending on the contaminants. This method combines the effectiveness of UV in killing microorganisms with residual hydrogen peroxide to keep the pipes clean and abate microbial growth in the reclaimed water storage tank. The residual hydrogen peroxide can last up to days, like chlorine, depending on the water and system conditions, such as exposure to air, sunlight, pH, temperature, relative impurity levels, and piping materials. However, the residual hydrogen peroxide does not produce the harmful byproducts, such as trihalomethanes, associated with chlorine or bromide. HRT also does not kill grass, whereas chemical alternatives such as chlorine can kill grass. HRT is a relatively new treatment method to be implemented in commercial buildings; additional studies are pending for this method as well as other AOPs (Soderholm 2012).

Table 4.1 Contaminants removed or disinfected by common treatment methods

Treatment Method	Debris	Particulate	Microorganisms	Metals	VOCs	Comments
First flush	●	●	●			Only in rainwater flow path. Acts when rain begins. \$
Screening	●					Only in rainwater flow path. \$
Sedimentation	●	○				Minimal in condensate water. \$
Mechanical filtration		●	○			Small pores will capture microorganisms. \$
Active charcoal		●	○	○	○	Requires contact time to kill microorganisms. \$
Chlorination			●			Requires contact time to kill microorganisms. Continues to disinfect over time. Requires dosing system. Can kill grass and shrubbery when used for irrigation. Produces trihalomethanes and other byproducts. \$\$
Pasteurization			●			Only practical when ample waste heat is available. \$\$
Hydroxyl radical (example of AOP) ^a			●	○	○	Continues to disinfect over time. Requires chemical injection system. \$\$
UV light ^b			●			Removes particulate prior to UV treatment. \$\$–\$\$\$
Ozonation			●	○	○	Eliminates odors. Requires specialized training to operate. Corrosive. Produces bromide byproducts. \$\$–\$\$\$
Reverse osmosis		○	○	●	●	Consumes more process water than it treats.

● = yes, ○ = depends on contaminant characteristics and device specifications

^a Advanced oxidation process (AOP)

^b Ozonation is more cost effective than UV light for large reclaimed water systems (> 80 GPM) and less cost effective than UV for smaller systems.

Reverse Osmosis

Reverse osmosis is a membrane process capable of removing microorganisms, chemical contaminants, heavy metals, sediment, and some VOCs from water. It is only used if needed to capture contaminants that other methods cannot remove. Even though reverse osmosis is effective in removing microorganisms, it is not advisable to rely solely on reverse osmosis if water is contaminated with microorganisms. Ultraviolet (UV) purification or chlorination is recommended in conjunction with reverse osmosis. Reverse osmosis uses several times more process water than it purifies in the treatment process. This can be a significant water conservation consideration if this process water is not itself reclaimed. So reverse osmosis is not recommended unless the application requires potable water for drinking or laboratory applications.

References

Burns, Chester R. "Epidemic Diseases." *The Handbook of Texas Online*. <www.tshaonline.org/handbook/online/articles/sme01> Accessed 14 March 2013.

Environmental Protection Agency. 2004. *2004 Guidelines for Water Reuse*. EPA 625-R-04-108. Washington, DC.

Environmental Protection Agency. 2012. *2012 Guidelines for Water Reuse*. EPA 600-R-12-618. Washington, DC.

International Code Council. 2012. *2012 International Green Construction Code [IGCC]*.

Mechell, Justin, Billy Kniffen, Bruce Lesikar, Douglas Kingman, Fouad Jaber, Rachel Alexander, and Brent Clayton. 2010. *Rainwater Harvesting: System Planning*. B-6240. College Station: Texas A&M Agrilife Extension Service.

Munters Incorporated. "H2O Liquid Air." <www.munters.us> Accessed 14 March 2013.

National Water Research Institute. 2012. *2012 Ultraviolet Disinfection Guidelines for Drinking Water and Water Reuse*, 3rd ed. Fountain Valley, CA.

Soderholm, Brian. 2012. Water Control Corporation. Personal communication.

Taylor, Howard E. 1995. "Fundamentals of Ozone Generation, Reactions and Applications." Florida Department of EPA Annual Meeting. Satellite Beach, FL.

5

Water Quality Requirements, Guidance, and Monitoring

Water Quality Requirements

The acceptable quality of reclaimed water for on-site applications is determined by local and state regulations (Bruursema 2011). This differs from drinking water, which is governed by federal regulations. The Texas Administrative Code (TAC) governs the water quality requirements for “industrial reclaimed water,” which includes condensate. See Chapter 2 for details on the TAC for industrial reclaimed water. Highlights of Chapter 2 relevant to condensate quality and monitoring are summarized here.

If condensate is used for internal recycling systems, closed loop systems or systems that use industrial wastewater as makeup water within a facility, the water does not require sampling or authorization by the TAC [TAC§210.51].

When used for predetermined applications listed in Table 2.3, such as irrigation, the condensate is eligible for Level I authorization by TAC if it does not exceed maximum allowable levels (MAL) of contaminants (see Appendix A) per a preliminary single water sample test. TAC does not require subsequent sampling of Level I water. Since condensate from Air-Handling Units (AHUs) is theoretically pure water, the only expected contaminants are those present in the moist air entering the AHU (from which condensate was derived), metals from the drain lines forming the condensate flow path, and microbes incurred primarily in water storage tanks. Therefore, the type and extent of contamination in reclaimed condensate is relatively predictable. Condensate from AHUs is expected to test below the MAL for contaminants listed in Appendix A.

When used for applications not listed in Table 2.3, condensate may be eligible for Level II authorization by TAC (see Table 2.4). Level II authorized water requires a weekly pH test and a monthly organic carbon test. Acceptable pH range is 6-9 su and acceptable organic carbon is less than or equal to 55 mg/l. If condensate is commingled with water from other sources, such as rainwater, an increase in organic content and related contaminants is expected, making testing for organic carbon more relevant. If considering commingling condensate with water from other sources, see Chapter 2 for water sources eligible for on-site use and TAC§210.54(a) for waste water not eligible for on-site use.

Although San Antonio has not adopted the Green Plumbing and Mechanical Code Supplement (GPMCS) or the International Green Construction Code (IGCC), their quality thresholds are worth mentioning for consideration when condensate is commingled with rain water. The GPMCS imposes a quality threshold for rainwater of E. coli less than 100 CFU/100 ml and turbidity less than 10 NTU for common urban reclaimed water applications such as water features and cooling tower makeup water [GPMCS§505.9.4]. The International Green Construction Code (IGCC) imposes quality thresholds for rainwater of pH between 6-7, BOD 10 mg/l, NTU ≤ 2, no detectable fecal coliform/100 ml, no detectable chlorine in 100 ml, and no detectable enteroviruses/100 ml [IGCC§707.12.10].

Water Quality Guidance

In addition to the requirements imposed by the TAC, guidance documents provide useful best practices and proposed standards primarily directed at protecting public health. Several guidance documents are available that address the control of pathogenic microorganisms for non-potable applications. The *NSF/ANSI Standard 350: On-site Residential and Commercial Water Reuse Treatment Systems* addresses effluent quality of non-potable water for a wide range of applications including toilet flushing and surface irrigation (National Sanitation Foundation 2011a). These effluent quality requirements for reclaimed water from sources in commercial/industrial buildings as defined in Standard 350 are outlined in Table 5.1. Overall test average for this standard is defined as the geometric mean of 26 weeks of continuous testing with regularly scheduled sampling throughout, typically three days a week. Single sample maximum is defined as the maximum allowable value for a single sample. Since these standards account for all types of influent (e.g., rainwater and graywater), organic contaminants are a primary concern.

Table 5.1 Summary of NSF Standard 350 effluent criteria for reclaimed water in commercial buildings (Source: Bruursema 2011^a)

Parameter	Overall test average	Single sample maximum
CBOD ₅ (mg/l) ^b	10	25
TSS (mg/l) ^c	10	30
Turbidity (NTU)	2	5
<i>E. coli</i> (MPN/100 ml) ^e	2.2	200
pH (su)	6-9	NA ^e
Storage vessel disinfection (mg/l) ^f	≥0.5 to ≤2.5	NA
Color	MR ^g	NA
Odor	Non-offensive	NA
Oily film and foam	Non-detectable	Non-detectable
Energy consumption	MR	NA

^a Reprinted with permission from “The New NSR 350 and 350-1” by Tom Bruursema in *Plumbing Systems & Design* magazine, October 2011. © American Society of Plumbing Engineers.

^b CBOD₅ = Five-day carbonaceous biochemical oxygen demand

^c TSS = Total suspended solids

^d Calculated as geometric mean

^e NA = Not applicable

^f As chlorine. Other disinfectants can be used

^g MR = Measured and reported only

Table 5.2 Summary of NSF Standard 350-1 effluent criteria for reclaimed water in commercial buildings for subsurface discharge only (Source: Bruursema 2011^a)

Parameter	Overall Test Average
CBOD ₅ (mg/l) ^b	25
TSS (mg/l) ^c	30
pH (su)	6–9
Color	MR ^d
Odor	Non-offensive
Oily film and foam	Non-detectable
Energy consumption	MR

^a Reprinted with permission from “The New NSF 350 and 350-1” by Tom Bruursema in *Plumbing Systems & Design* magazine, October 2011. © American Society of Plumbing Engineers.

^b CBOD₅ = Five-day carbonaceous biochemical oxygen demand

^c TSS = Total suspended solids

^d MR = Measured and reported only

The complementary *NSF/ANSI Standard 350-1: On-site Residential and Commercial Graywater Treatment Systems for Subsurface Discharge* addresses subsurface discharge only (National Sanitation Foundation 2011b). The less stringent requirements for subsurface-only discharge of reclaimed water are outlined in Table 5.2. Although *NSF/ANSI Standard 350-1* focuses on treatment of graywater influent (e.g., bathwater and laundry water) and the resulting effluent quality, the effluent quality thresholds are worth considering for condensate as they are application based.

The *EPA 2012 Guidelines for Water Reuse* suggest water quality thresholds and monitoring practices for municipal reclaimed (i.e., recycled) water for specific water application categories, as outlined in Table 5.3 (Environmental Protection Agency 2012). Although the EPA guidance contained in Table 5.3 is directed at municipal reclaimed water, the limits are intended to protect human health and in that respect are relevant to on-site reclaimed water in commercial buildings.

The reuse categories in Table 5.3 are divided into unrestricted and restricted use. The unrestricted use naturally requires more treatment than restricted use applications because of the higher likelihood of body-contact, inhalation, or ingestion of the reclaimed water. See *EPA 2012 Guidelines for Water Reuse* for additional applications not listed in Table 5.3 including: agricultural, environmental, groundwater recharge, and indirect potable use, which are more applicable to municipal reclaimed (recycled) water systems than on-site reclaimed water systems in commercial facilities.

Since it is not practical to routinely monitor reclaimed water for all pathogenic organisms of concern, indicator organisms, often referred to as surrogates, are commonly measured instead to determine the disinfection efficiency. If the disinfection efficiency is deemed adequate based on the surrogate measurements, it is assumed the pathogenic organisms of concern are below the maximum allowable limits.

Total and fecal coliforms are commonly used indicator organisms in reclaimed water as a measure of disinfection efficiency. “While coliforms are used as indicator organisms for many bacterial pathogens, they are, by themselves, poor indicators of parasites and viruses” (Environmental Protection Agency 2012). Total coliform detects organisms of fecal and non-fecal origin, while fecal coliform detects organisms of fecal origin only. The fact that condensate alone is not expected to contain fecal matter makes fecal coliform measurements trivial for condensate collection systems unless the condensate is commingled with another reclaimed water source that may include fecal matter, such as rainwater. So a measure of total coliform is more appropriate for on-site reclaimed water systems containing only condensate. “Alternative indicator organisms that may be adopted in the future for water quality monitoring include: *Enterococci*, *Bacteroides*, and new choices of bacteriophages” (Environmental Protection Agency 2012).

The EPA guidelines outlined in Table 5.3 do not include suggested limits for specific parasites or viruses. Two parasites of considerable interest in recent years are *Giardia* and *Cryptosporidium*. “However, parasite levels, where they have been monitored for at water reuse (i.e., municipal reclaimed or recycled water) operations in the United States, and at the treatment and quality limits recommendations in (the EPA) guidelines have been deemed acceptable” (Environmental Protection Agency 2012). Similarly, there have been no documented cases of viral disease resulting from municipal water reuse (i.e., recycled water) operations in the United States (Environmental Protection Agency 2012).

Many pathogens are particulate-associated, and that particulate matter can shield the bacteria and viruses from disinfectants such as chlorine and UV radiation. Furthermore, particulate matter of an organic nature consumes chlorine, thus making the chlorine less available for disinfection. “There is general agreement that particulate matter should be reduced to low levels, e.g., 2 NTU or 5 mg/l total suspended solids (TSS), prior to disinfection to ensure reliable destruction of pathogenic microorganisms during the disinfection process” (Environmental Protection Agency 2012).

Table 5.3 EPA suggested water quality and monitoring for municipal water reuse^a (Source: adapted from Environmental Protection Agency 2012)

Reuse Category and Description	Treatment	Reclaimed Water Quality ^b	Reclaimed Water Monitoring	Comments
<p>Urban Reuse</p> <p>Unrestricted The use of reclaimed water in non-potable applications in municipal settings where public access is not restricted.</p>	<p>Secondary^c Filtration^d Disinfection^e</p>	<p>pH = 6–9 ≤ 10 mg/l BOD^f ≤ 2 NTU^g No detectable fecal coli/100 ml^{h, i} 1 mg/l Cl₂ residual (min)^j</p>	<p>pH—weekly BOD—weekly Turbidity—continuous Fecal coliform—daily Cl₂ residual—continuous</p>	<ul style="list-style-type: none"> At controlled-access irrigation sites where design and operational measures significantly reduce the potential of public contact with reclaimed water, a lower level of treatment, e.g. secondary treatment and disinfection to achieve <14 fecal coli-form/100 ml may be appropriate. Chemical (coagulant and/or polymer) addition prior to filtration may be necessary to meet water quality recommendations. The reclaimed water should not contain measurable levels of pathogens.^k Reclaimed water should be clear and odorless. Higher chlorine residual and/or a longer contact time may be necessary to assure that viruses and parasites are inactivated or destroyed. Chlorine residual >0.5 mg/l in the distribution system is recommended to reduce odors, slime, and bacterial regrowth. Setback distance 50 ft (15 m) to potable water supply wells; increase to 100 ft (30 m) when located in porous media^{l, o} See Section 3.4.3 in the 2004 guidelines for recommended treatment reliability requirements (EPA 2004).
<p>Restricted The use of reclaimed water in non-potable applications in municipal settings where public access is controlled or restricted by physical or institutional barriers, such as fencing, advisory signage, or temporal access restriction</p>	<p>Secondary^c Disinfection^e</p>	<p>pH = 6–9 ≤ 30 mg/l BOD^f ≤ 30 mg/l TSS ≤ 200 fecal coli/100 ml^{h, m, n} 1 mg/l Cl₂ residual (min)^j</p>	<p>pH—weekly BOD—weekly TSS—daily Fecal coliform—daily Cl₂ residual—continuous</p>	<ul style="list-style-type: none"> If spray irrigation, TSS less than 30 mg/l may be necessary to avoid clogging of sprinkler heads. See Section 3.4.3 in the 2004 guidelines for recommended treatment reliability requirements. For use in construction activities including soil compaction, dust control, washing aggregate, making concrete, worker contact with reclaimed water should be minimized and a higher level of disinfection (e.g. < 14 fecal coli/100 ml) should be provided when frequent worker contact with reclaimed water is likely. Setback distance 300 ft (90 m) to potable water supply wells; 100 ft (30 m) to areas accessible to the public (if spray irrigation)^l

continued

Table 5.4 continued

Reuse Category and Description	Treatment	Reclaimed Water Quality ^b	Reclaimed Water Monitoring	Comments
<p><u>Unrestricted</u> The use of reclaimed water in an impoundment in which no limitations are imposed on body-contact.</p>	<p>Secondary^c Filtration^d Disinfection^e</p>	<p>pH = 6–9 ≤ 10 mg/l BOD^f ≤ 2 NTU^g No detectable fecal coli/100 ml^{h,i} 1 mg/l Cl₂ residual (min)^j</p>	<p>pH—weekly BOD—weekly Turbidity—continuous Fecal coliform—daily Cl₂ residual—continuous</p>	<ul style="list-style-type: none"> • Dechlorination may be necessary to protect aquatic species of flora and fauna. • Reclaimed water should be non-irritating to skin and eyes. • Reclaimed water should be clear and odorless. • Nutrient removal may be necessary to avoid algae growth in impoundments. • Chemical (coagulant and/or polymer) addition prior to filtration may be necessary to meet water quality recommendations. • Reclaimed water should be not contain measurable levels of pathogens.^k • Higher chlorine residual and/or a longer contact time may be necessary to assure that viruses and parasites are inactivated or destroyed. • Fish caught in impoundments can be consumed. • Setback distance 500 ft (150 m) to potable water supply wells (min.) if bottom not sealed.^l • See Section 3.4.3 in the 2004 guidelines for recommended treatment reliability requirements (EPA 2004).
<p><u>Restricted</u> The use of reclaimed water in an impoundment where body-contact is restricted.</p>	<p>Secondary^c Disinfection^e</p>	<p>≤ 30 mg/l BOD^f ≤ 30 mg/l TSS ≤ 200 fecal coli/100 ml^{h,m,n} 1 mg/l Cl₂ residual (min)^j</p>	<p>pH—weekly TSS—daily Fecal coliform—daily Cl₂ residual—continuous</p>	<ul style="list-style-type: none"> • Nutrient removal may be necessary to avoid algae growth in impoundments. • Dechlorination may be necessary to protect aquatic species of flora and fauna. • Setback distance 500 ft (50 m) to potable water supply wells (min.) if bottom not sealed.^l • See Section 3.4.3 in the 2004 guidelines for recommended treatment reliability requirements (EPA 2004).

continued

Table 5.4 continued

Reuse Category and Description	Treatment	Reclaimed Water Quality ^b	Reclaimed Water Monitoring	Comments
Industrial Reuse^P				
<u>Once-through Cooling</u>	Secondary ^c	pH = 6–9 ≤30 mg/l BOD ^f ≤ 30 mg/l TSS ≤ 200 fecal coli/100 ml ^{h, m, n} 1 mg/l Cl ₂ residual (min) ^j	pH—weekly BOD—weekly TSS—daily Fecal coliform—daily Cl ₂ residual—continuous	<ul style="list-style-type: none"> • Windblown spray should not reach areas accessible to workers or the public. • Setback distance 300 ft (90 m) to areas accessible to the public.
<u>Recirculating Cooling Towers</u>	Secondary ^c Disinfection ^e (chemical coagulation and filtration ^d may be needed)			<ul style="list-style-type: none"> • Water quality is variable and depends on recirculation ratio of the cooling tower • Windblown spray should not reach areas accessible to workers or the public. • Additional treatment by users in usually provided to prevent scaling, corrosion, biological growths, fouling, and foaming • Setback distance 300 ft (90 m) to areas accessible to the public. May be reduced if high level of disinfection is provided.^l • See Section 3.4.3 in the 2004 guidelines for recommended treatment reliability requirements (EPA 2004).
				<p>a These guidelines are based on water reclamation and reuse practices in the U.S. and are specifically directed at states that have not developed their own regulations or guidelines</p> <p>b Unless otherwise noted, recommended quality limits apply to the reclaimed water at the point of discharge from the treatment facility</p> <p>c Secondary treatment process include activated sludge process, trickling filters, rolling biological contactors, and may stabilize pond systems. Secondary treatment should produce effluent in which both the BOD and SS do not exceed 30 mg/l</p> <p>d Filtration means the passing of wastewater through natural undisturbed soils or filter media such as sand and/or anthracite; or the passing of wastewater through microfilters or other membrane processes.</p> <p>e Disinfection means the destruction, inactivation, or removal of pathogenic microorganisms by chemical, physical, or biological means. Disinfection may be accomplished by chlorination, ozonation, other chemical disinfectants, UV, membrane processes, or other processes.</p> <p>f As determined from the 5-day BOD test.</p> <p>g The recommended turbidity should be met prior to disinfections. The average turbidity should be based on a 24-hour time period. The turbidity should not exceed 5 NTU at any time if SS is used in lieu of turbidity, the average SS should not exceed 5 mg/l. If membranes are used as the filtration process, the turbidity should not exceed 0.2 NTU and the average SS should not exceed 0.5 mg/l.</p> <p>h Unless otherwise noted, recommended coliform limits are median values determined from the bacteriological results of the 7 days for which analysis have been completed. Either the membrane filter or fermentation tube technique may be used.</p> <p>i The number of total or fecal coliform organisms (whichever one is recommended for</p> <p>j monitoring in the table) should not exceed 14/100 ml in any sample.</p> <p>k This recommendation applies only when chlorine is used as the primary disinfectant.</p> <p>l The total chlorine residual should be met after a minimum actual modal contact time of at least 90 minutes unless a lesser contact time has been demonstrated to provide indicator organism and pathogen reduction equivalent to those suggested in these guidelines. In no case should the actual contact time be less than 30 minutes.</p> <p>m It is advisable to fully characterize the microbiological quality of the reclaimed water prior to implementation of a reuse program</p> <p>n Setback distances are recommended to protect potable water supply sources from contamination and to protect humans from unreasonable health risks due to exposure to reclaimed water.</p> <p>o The number of fecal coliform organisms should not exceed 800 / 100 ml in any sample.</p> <p>p Some stabilization pond systems may be able to meet this coliform limit without disinfection.</p> <p>q See Section 4.4.3.7 for additional precautions that can be taken when a setback distance of 100 ft (30 m) to a potable water supply well in porous media is not feasible. (EPA 2012)</p> <p>r Other industrial uses — e.g. boiler feed equipment washdown processing power generation and in the oil and natural gas production market (including hydraulic fracturing have requirements that depend on the site-specific end use.</p>

Continuous monitoring of turbidity provides immediate feedback for real-time adjustments of filtration and is recommended over periodic measurements. In addition to consuming chlorine, organic matter consumes oxygen, provides food for microorganisms, hinders the disinfection process, and may cause unpleasant odors and discoloration. “The recommended biochemical oxygen demand (BOD) limit is intended to indicate that the organic matter has been stabilized, is non-putrescible, and has been lowered to levels commensurate with anticipated types of reuse” (Environmental Protection Agency 2012). *Putrescible* is a term used to describe matter that is liable to become putrid (i.e., rot or decompose). Chlorine disinfection efficacy is typically measured in terms of CT, which is the product of the total chlorine residual multiplied by the contact time (Environmental Protection Agency 2012).

Setback distances for reclaimed water systems are for two purposes: to protect potable water sources (such as wells) and to protect individual humans from exposure. Protecting potable water sources involves preventing infiltration of reclaimed water into the potable water source or system. Protecting individual human exposure via setbacks involves preventing aerosols from reaching the public where they can be inhaled, deposited on food and ingested, or deposited on clothing and vegetation where bodily contact is a risk (Environmental Protection Agency 2012).

Viruses, most pathogenic bacteria, and pathogenic protozoa are in the respirable size range. Therefore, inhaling infected aerosols is a direct means of human infection. “The infective dose of some pathogens is lower for respiratory infections than for infections via the gastrointestinal tract; thus, for some pathogens, inhalation may be a more likely route for disease transmission than either contact or ingestion” (Environmental Protection Agency 2012). Legionnaires’ disease is the most recognized respiratory illness resulting from the inhalation of bacteria (i.e., *Legionella*) suspended in an aerosol of infected water. Consider both the setback distance and the water treatment methods when assessing risk to public health for reclaimed water used in systems that generate aerosols, such as cooling towers and above surface irrigation.

Like the EPA guidance in Table 5.3, the TAC requirements contained in Table 5.4 are directed at municipal reclaimed (i.e., recycled) water systems. Consistent with the EPA guidance, TAC requirements are divided into two categories for all applications: unrestricted use (Type I) and restricted (Type II). Although these requirements do not apply to industrial reclaimed water, such as condensate, the requirements are still informative as they are intended to protect human health. The monitoring guidance in Table 5.3 and monitoring requirements in Table 5.4 for municipal reclaimed water systems can be considered when developing monitoring protocols for on-site reclaimed systems, especially when multiple reclaimed water sources are combined that contain an organic component.

Table 5.4 Quality monitoring requirements in Texas for municipal reclaimed (recycled) water (Source: Environmental Protection Agency 2012)

Texas Category	Is Human Contact Likely?	Examples	Monitoring Frequency	Enterococci (MPN/100ml) ^a	Fecal Coliforms or E. coli (MPN/100ml) ^a	CBOD ₅ or BOD ₅ (mg/l)	Turbidity (NTU)
Type I	Yes	Irrigation, recreational impoundments, firefighting, toilet flush water	Twice weekly	9/4 ^b	75/20 ^b	5	3
Type II	No	Restricted or remote reuse	Once weekly	35	800/200 ^b	15 or 20 ^c	NA

^a MPN = Most probably number of organisms

^b The first value represents a single sample maximum value and the next value refers to a 30-day average (BOD₅ and Turbidity) or 30-day geometric mean (fecal coliform or E. coli)

^c In Type II users, the CBOD₅ maximum 30-day average value is 15mg/l while the BOD₅ value is 20 mg/l for the same period

Texas does not specify the treatment process for municipal reclaimed (i.e., recycled) water to reach water quality limits, whereas other states do. The explicit design standards and treatment required by other states for municipal reclaimed water can be found in state regulations through the Environmental Protection Agency (EPA) website <<https://www.wateruse.org/government-affairs/usepa-guidelines>> and include but are not limited to oxidation, coagulation, and filtration (Environmental Protection Agency 2012)

Setting Water Quality Objectives

Setting appropriate contaminant thresholds for on-site reclaimed systems varies case-by-case based on the known water sources (i.e., influents) and intended use of the treated water (i.e., effluent). It is ultimately the responsibility of the reclaimed water system designer to determine which water quality thresholds are most appropriate, beyond those required by the TAC, for the intended application. Hiring a water treatment expert with experience designing reclaimed water systems facilitates achieving an effective system.

Water Quality Monitoring

A combination of treatment process requirements and water quality limits is recommended to enhance reliability of meeting water quality goals. The treatment process requirements institute measures expected to purify the water of unwanted contaminants, the foremost being pathogens. The water quality limits set the degree of purification necessary to meet water quality goals for the intended use of the reclaimed water. Monitoring provides a means to verify that the treatment system is operating properly and that the water quality goals are met.

Table 5.5 shows the recommended continuous monitoring practices for various treatment methods to confirm effective system operation in terms of filtration and disinfection (Soderholm 2012). Continuous monitoring can be tied into fail-safe systems, which activate a bypass mechanism to deliver municipal water to the application when unsafe on-site reclaimed water conditions are detected.

Table 5.5 Recommendations for constant (automated) monitoring

Treatment Method	Monitoring
Mechanical filtration	Monitor the differential pressure through the filters
Chlorination and ozonation	Monitor chemical levels directly or use oxidation-reduction potential (ORP) monitoring to control the system
Hydroxyl radical (example of AOP) ^a	Monitor the hydrogen peroxide (H ₂ O ₂) residual in the water
UV light	Monitor UV intensity levels
Turbidity	Continuously if using UV treatment. Otherwise, periodically. Will be visible in applications like toilet flushing.
Reverse osmosis	Monitor total dissolved solids (TDS) levels, pH, etc.

^a Advanced oxidation process (AOP)

Once the treatment system is proven to remove contaminants from the influent reclaimed water, continuous automated monitoring of the system confirming effective operation enables less frequent sampling of the effluent for contaminants. Sampling the effluent for unwanted contaminants becomes a verification measure, to detect anomalies resulting from unexpected influent conditions or treatment system malfunctions not detected by the assigned monitoring. This is especially true for on-site reclaimed water systems in which condensate is the only influent, since condensate contaminants are relatively predictable.

Therefore, when continuous monitoring (per Table 5.5) is employed, it is common practice to manually monitor some qualities of the water less frequently than if continuous monitoring were not employed. Table 5.6 lists some common manual monitoring practices when various continuous monitoring is in place for reclaimed condensate systems (Soderholm 2012).

Table 5.6 Common periodic (manual) monitoring of reclaimed water systems

Quality	Monitoring
pH	If for irrigation, monthly during irrigation season.
BOD	If automatic continuous monitoring listed in Table 5.4 is used, every 3–6 months. If continuous monitoring is not used, monthly.
Turbidity	Continuously if using UV treatment. Otherwise, periodically. Will be visible in applications like toilet flushing.
Coliform	If automatic continuous monitoring listed in Table 5.4 is used, then every 6–12 months. If continuous monitoring is not used, monthly.
Cl ₂ residue	If using chlorine, continuous ORP provides Cl ₂ residue. Otherwise monthly.

The push for a national standard of treatment quality and treatment product evaluation may lead to NSF/ANSI standards, ASHRAE Standard 191, or similar guidance being adopted by codes, such as the IGCC or San Antonio Building Codes. In the meantime, the designer and installer of the on-site reclaimed water system in San Antonio must adhere to the TAC requirements while implementing best practices gleaned from sources such as those outlined in this chapter.

Ensuring that the reclaimed water system produces adequate water quality for the intended use is the joint responsibility of the designer and installer. Maintaining this quality is the responsibility of the building owner through effective operation and maintenance of the system (see Chapter 11). Hiring a water treatment expert with experience designing reclaimed water systems facilitates achieving an effective system.

References

- Bruursema, Tom. 2011. "The New NSF 350 and NSF 350-1." *Plumbing Systems & Design Magazine*. 20 October: 14-22.
- Environmental Protection Agency. 2004. *2004 Guidelines for Water Reuse*. EPA 625-R-04-108. Washington, DC.
- Environmental Protection Agency. 2012. *2012 Guidelines for Water Reuse*. EPA 600-R-12-618. Washington, DC.
- International Association of Plumbing and Mechanical Officials. 2012. *2012 Green Plumbing and Mechanical Code Supplement* [GPMCS].
- National Sanitation Foundation. 2011a. *NSF/ANSI Standard 350: Onsite Residential and Commercial Water Reuse Treatment Systems*. Ann Arbor, MI.
- National Sanitation Foundation. 2011b. *NSF/ANSI Standard 350-1: Onsite Residential and Commercial Graywater Treatment System for Subsurface Discharge*. Ann Arbor, MI.
- Soderholm, Brian. 2012. Water Control Corporation. Personal communication.

6

Selection of Water Treatment Methods for Common Applications

“Treatment of reclaimed water is and should be tailored to a specific purpose so that treatment objectives can be appropriately set for public health and environmental protection, while being cost effective” (Environmental Protection Agency 2012a). This concept of tailoring treatment to a specific purpose is referred to as “Fit for Purpose.”

As technologies are now advanced enough to treat wastewater to the water quality required for the intended use, it is important to know the potential contaminants in the water source as well as the intended application to select the optimal combination of treatment methods. In the case of condensate, it does not contain large debris or concentrated particulate, so diversion of first flush and screening can be skipped. Condensate also does not contain fecal matter. So the likely contaminants in condensate are incidental microorganisms, such as *Legionella*, and metals from the air-handling unit (AHU) cooling coils, drain pan, or any other components along the condensate flow path.



When rainwater is combined with condensate in a reclaimed water system, screening of the rainwater along with sedimentation and rigorous treatment for contamination via fecal matter is advised. In addition, a first flush device must be installed to capture and dispose of the most heavily contaminated water coming from the rainwater capture surface, such as a roof, at the beginning of a rain event. The first flush device must be upstream of the condensate input to the combined system or must accommodate condensate water passing through the first flush device to the storage tank at low flow rates (i.e., it is counterproductive to capture condensate in a first flush device).

The treatment train must be designed on a case-by-case basis by a qualified professional to satisfy the water quality for the intended application. The Environmental Protection Agency (EPA) suggests primary and secondary disinfection for all common reclaimed/recycled water applications (Environmental Protection Agency 2004). Primary treatment is the first disinfectant used in a treatment system, with the primary objective being to achieve the necessary microbial inactivation. The secondary disinfection used in a treatment system is implemented to maintain the disinfection residual through the distribution system, including the reclaimed/recycled water storage tank. Examples of secondary disinfection methods are chlorination, injection of peroxide in hydroxyl radical treatment, and continuous recirculation of the reclaimed water through the system with ozonation or UV disinfection present in the recirculation loop. Residual chlorine and hydrogen peroxide can remain in the system up to several days, depending on water and system conditions such as exposure to air, sunlight, and piping materials. If an unacceptable level of particles, including microorganisms and dissolved organic and inorganic constituents remain after secondary treatment, further filtration, disinfection and/or advanced treatment is required. Numerous options are available for advanced treatment (see advanced oxidation processes in Chapter 4). Advanced treatment is used for higher levels of water purification, especially when

condensate is commingled with other water sources such as rainwater or graywater, which inherently contain more contaminants than condensate.

Table 6.1 shows the types of reuse appropriate for increasing levels of treatment, as outlined in the *EPA 2012 Water Reuse Guidelines*. End uses such as groundwater recharge are more applicable to municipal reclaimed (recycled) water than to reclaimed water from commercial buildings for on-site use, but are included here for reference.

Table 6.1 Types of reuse appropriate for increasing levels of treatment (Source: EPA 2012a)

Treatment Level	Increasing Levels of Treatment			
	Primary	Secondary	Filtration and Disinfection	Advanced
Processes	Sedimentation	Biological oxidation and disinfection	Chemical coagulation, biological or chemical nutrient removal, filtration, and disinfection	Activated carbon, reverse osmosis processes, soil aquifer treatment, etc.
End Use	No Uses Recommended	Surface irrigation of orchards and vineyards	Landscape and golf course irrigation	Indirect potable reuse including groundwater recharge of potable aquifer and surface water reservoir augmentation and potable reuse
		Non-food crop irrigation	Toilet flushing	
		Restricted landscape impoundments	Vehicle washing	
		Groundwater recharge of non-potable aquifer	Food crop irrigation	
		Wetland, wildlife habitat, stream augmentation	Unrestricted recreational impoundment	
		Industrial cooling processes	Industrial systems	
Human Exposure	Increasing Acceptable Levels of Human Exposure 			
Cost	Increasing Levels of Cost 			

In all cases, non-potable water for each end use application must meet the minimum water quality requirements as established for the application by the laws, rules, and ordinances applicable in the jurisdiction having authority [IGCC§706.3, GPMCS§501.7]. Additional design considerations for some common applications are outlined below.

Cooling Tower

Cooling tower water is continuously consumed in the evaporative cooling process of the tower, thereby requiring that a continuous supply of water be added to the cooling tower. In addition, periodic discharge and replenishing of a portion of the recirculation water is necessary to dilute the concentrate of total dissolved solids (TDS), including meal salts, accumulated in the cooling tower from potable water. This process is commonly referred to as blowdown. Condensate, due to its relatively low pH, acts to dilute the TDS and extend the time between blowdown events, thereby saving even more water than simply replacing the potable makeup water to the cooling tower with equal quality water (Painter 2009). Since cooling tower water is monitored and treated to maintain a pH in the 7.2-8.2 range to prevent corrosion, to dissolve or remove metal salts that plate onto the cooling tower surfaces as scale, and to combat microorganisms such as fungi and bacteria, no additional treatment is necessary when condensate water is added to the existing cooling tower water.

During the evaporative cooling process, water passes over high surface area structures of the cooling tower and forms drips, spray, or mist, depending on operating conditions and the wind velocity in the vicinity of the cooling tower. Since most pathogenic bacteria and pathogenic protozoa are small enough to be suspended in aerosol water particles (i.e., less than 50 mm in diameter), they can be inhaled. Inhalation of infected aerosols from cooling tower water is a possible direct means of infection (EPA 2012a). Infected aerosols or spray can also deposit on surfaces such as food, vegetation, and clothing and transmit disease by contact or ingestion.

Drift eliminators can be implemented as a precautionary measure to prevent windblown cooling tower water spray from reaching areas accessible to workers or the public. The recommended setback distance of a cooling tower is 300 feet from areas accessible to the public (Environmental Protection Agency 2004). In addition, the International Green Construction Code (IGCC) limits drift losses¹ and requires that cooling towers and fluid coolers be located so as to prevent discharge vapor plumes from entering occupied spaces. More specifically, the plume discharges must be not less than 5 feet above and 20 feet away from any ventilation inlet to a building [IGCC§703.7.1].

If additional treatment is added as a precautionary measure in case human exposure occurs, UV and ozone are common choices for cooling towers. The Occupational Safety and Health Administration (OSHA) suggested guideline for *Legionella* concentration in cooling towers, evaporative condensers, and fluid coolers is less than 10 CFU/ml (Occupational Health and Safety Administration 2013).

Process Water

Depending on the specific process, process water considerations may be similar to cooling tower water, or require additional treatment and/or storage similar to the applications listed below. Process water must be examined on a case-by-case basis to determine process-specific treatment requirements.

Subsurface Irrigation

Recommended limits for constituents in reclaimed water for irrigation can be found in EPA's *Guidelines for Water Reuse* (2004). A simple pH-neutralizing device composed of limestone or marble chips can be used to raise the pH level of the condensate if desired. Reclaimed water must be filtered by a 0.004-inch filter or finer for irrigation applications [IGCC§709.5.1]. Although water treatment is not required for subsurface irrigation because human exposure to the water is not expected, treatment is commonly employed for various reasons [GPMCS§501.7].

Metals can be removed by a membrane, reaction, and/or filter process if necessary; although designing the system to avoid metal reactions is preferred. If water stagnates for a period of time in the storage tank, microbial growth is commonly mitigated by ozonation, or chlorination, especially when rainwater is combined with condensate in the storage tank. Since chlorine can kill grass, its use in water purification for irrigation must be carefully considered.

Above-Ground Irrigation

Viruses and most pathogenic bacteria can become suspended in aerosols with particles small enough to inhale, hence the inhalation of contaminated aerosols is a possible direct cause of human infection (Environmental Protection Agency 2004). Therefore, above-ground irrigation with reclaimed water, which can potentially expose humans to contact and inhalation of reclaim water, is subject to the approval of the code official based on the extent of water purification [IGCC§709.5.1].

¹ Drift losses not greater than 0.002 percent of the recirculated water volume for counter-flow systems and not greater than 0.005 percent of the recirculated water for cross-flow systems [IGCC§703.7.5].

Requirements and recommendations for above-ground irrigation are the same as for subsurface irrigation plus the additional requirement that the water is sufficiently disinfected to mitigate risk to human health [GPMCS§504.10.2]. Exceptions can be made for above-ground irrigation systems that are used during times and in locations where human contact is unlikely, commonly referred to as “restricted use” applications.

Trap Primers

The IGCC prohibits the use of potable water to prime traps where a graywater, municipal recycled water or an alternate non-potable water distribution system is present at the site [IGCC§702.9]. Trap primers cannot provide a continuous flow of water, and water usage is limited to 30 gallons of water per year per trap [IGCC§702.9.1, IGCC§702.9.2]. A filter preventing passage of particulates greater than 0.004 inch must be installed in the non-potable water line used to prime traps [GPMCS§504.11]. Chemical treatment is common when condensate is used to prime traps.

Water Features

Any application that risks human exposure must include an acceptable disinfection method [GPMCS§504.10.2]. Since water features often entice wading and splashing, they fall under the category of unrestricted impoundment in Table 5.3, unless isolated by a physical barrier, in which case they fall under the category of restricted impoundment. In either case, treatment is recommended to mitigate a wide variety of infections, including gastrointestinal, skin, ear, respiratory, eye, neurologic, and wound infections caused by contaminated water. The most commonly reported recreational water infection is diarrhea caused by germs such as *Cryptosporidium*, *Giardia*, *Shigella*, *Norovirus*, and *E. coli* (Center for Disease Control and Prevention 2011).

An additional reference source for unrestricted water impounds is the EPA's *Recreational Water Quality Criteria*, which is intended as guidance in establishing new or revised water quality standards (EPA 2012b).

Although the condensate itself may not contain pathogenic contaminants, once it is introduced into the water feature or water impound, it becomes vulnerable to contamination by the environment, humans, and animals and must therefore be treated along with the rest of the water in the water feature. Chemical treatment or continuous recirculation with UV light is often used for water features in which there is potential for human contact with the water.

The reactive nature of condensate can degrade architectural finishes such as concrete, stone, and metals over time. If this is a concern, consider including a preventative measure in the treatment train, such as a limestone contactor.

Flushing of Water Closets and Urinals

Dye can be added to the treated reclaim water used to flush water closets and urinals to distinguish it from potable water supplied to lavatory sinks in the same vicinity. A filter preventing passage of particulates greater than 0.004 inch must be installed in the non-potable water line used to flush water closets and urinals [GPMCS§504.11, IGCC§A107.4.2]. Any application that risks human exposure must include an acceptable disinfection method [GPMCS§504.10.2] that meets the minimal water quality requirements established for indoor flushing applications by local codes and regulations [IGCC§A107.4.1]. UV light, ozonation, and/or chemical treatment are common means to disinfect condensate used to flush toilets. Where chlorine is used, the non-potable water must contain not more than 4 mg/l of chloramines or free chlorine [IGCC§A107.4.1]. Where ozonation is used, the non-potable water must not contain gas bubbles having elevated levels of ozone at the point of use [IGCC§A107.4.1].

Drinking (Potable) Water

Water intended for drinking requires the highest level of treatment to ensure human health and safety per National Sanitation Foundation (NSF) Standards 42, 53, 58, 60, and 61. Treatment, testing, and authorization of drinking water systems in Texas must adhere to Chapter 290, Title 30 of the Texas Administrative Code (TAC) as well [TAC§290]. In addition, contaminants must not exceed acceptable levels regulated by the EPA as outlined in the *National Drinking Water Regulations* (Environmental Protection Agency 2009).

All materials contacting the potable water must comply with NSF Standard 61. If condensate water is intended specifically for potable use, it is recommended that an air-handling unit (AHU) specially designed to produce drinking water quality be purchased. Such an AHU includes food-grade coatings on the AHU cooling coils, drain pan, and drain lines to avoid contamination of the condensed water by metals and biological matter, as well as multiple disinfection methods to meet drinking water standards (Munters Incorporated 2013).

Drinking water applications of on-site reclaimed water must be approved by the water provider in the jurisdiction, i.e., SAWS. No potable water systems have been approved in San Antonio to date because of the potential health risks involved.

Other Applications

The general guideline for reclaimed/recycled water applications is that appropriate treatment is required to ensure human health and safety for the intended use. More specifically, follow the minimum water quality requirements as established for the application by the laws, rules, and ordinances applicable in the jurisdiction having authority [IGCC§706.3, GPMCS§501.7].

References

- Center for Disease Control and Prevention. "Recreational Water Illnesses." <www.cdc.gov/healthywater/swimming/rwi/> Accessed 28 August 2011.
- Environmental Protection Agency. 2004. *2004 Guidelines for Water Reuse*. EPA 625-R-04-108. Washington, DC.
- Environmental Protection Agency. 2009. *National Primary Drinking Water Regulations*. EPA 816-F-09-0004. Washington, DC.
- Environmental Protection Agency. 2012a. *2012 Guidelines for Water Reuse*. EPA 600-R-12-618. Washington, DC.
- Environmental Protection Agency. 2012b. *2012 Recreational Water Quality Criteria*. EPA 820-F-12-061. Washington, DC
- International Association of Plumbing and Mechanical Officials. 2012. *2012 Green Plumbing and Mechanical Code Supplement [GPMCS]*.
- International Code Council. 2012. *2012 International Green Construction Code [IGCC]*.
- Munters Incorporated. "H₂O LiquidAir." <www.munters.us> Accessed 14 March 13.
- Occupational Health and Safety Administration. "Legionnaire's Disease." <www.osha.gov/dts/osta/otm/legionnaires/cool_evap.html> Accessed 20 July 13.
- Painter, Frank L. 2009. "Condensate Harvesting from Large Dedicated Outside Air-Handling Units with Heat Recovery." *ASHRAE Transactions*, 115(2): 573-580.
- Texas Commission on Environmental Quality. *Texas Administrative Code [TAC]*, Title 30, Chapter 210. <www.sos.state.tx.us/tac/> Accessed 20 July 2012.

7

Condensate Rate Predictions

Accurately predicting the amount of condensate produced over time enables both the identification of practical uses of collected water for each building and the proper sizing of condensate collection system components. Predictions are dependent on a number of variables, including but not limited to outdoor air conditions, set points for indoor air conditions, heating, ventilating, and air-conditioning (HVAC) system type and settings, building type, and building use.

Equations and guidance in this chapter are provided to calculate rough estimates for typical commercial buildings using either hand calculations or an electronic spreadsheet. To obtain more accurate condensate predictions, the best course of action is to consult a licensed HVAC professional. They can assist in determining representative operating parameters over time for each specific building and perform calculations with advanced tools, such as building energy models¹ that incorporate detailed building information beyond the scope of this manual.

Rules of Thumb

Although rules of thumb do not provide the precision, accuracy, or time dependence of condensate prediction models, they enable quick estimates for perspective. The Alliance for Water Efficiency (AWE) estimates that the “amount of condensate water can range from 3 to 10 gallons per day (gpd) per 1,000 square feet (sq ft) of air-conditioned space” (Alliance for Water Efficiency 2012). Another estimate for typical condensate production is provided by San Antonio Water System (SAWS) for large buildings during summer months in San Antonio as 0.1 to 0.3 gallons per hour (gph) of water per ton of cooling or a peak rate of 0.5 to 0.6 gph per 1,000 square feet of cooled area (Guz 2005). Similarly, Bryant and Ahmed (2008) predicted condensate production for a normal commercial unit to be 8 gallons of condensate per ton of cooling for each day with a dew-point temperature in excess of 60°F.

Example 7.1 Here the rule-of-thumb estimates for condensate are applied to the Applied Engineering and Technology (AET) Building on the University of Texas at San Antonio campus. The 154,440-square-foot (sq ft) AET Building is cooled by multiple air-handling units (AHUs) with a total cooling capacity of 727 tons. The AHUs pull in 100% outside air.

AWE rule of thumb: $3 \text{ gpd}/1,000 \text{ sq ft} \times 154,440 \text{ sq ft} = 463 \text{ gpd} = 0.3 \text{ gpm}$

to $10 \text{ gpd}/1,000 \text{ sq ft} \times 154,440 \text{ sq ft} = 1,544 \text{ gpd} = 1.1 \text{ gpm}$

Bryant & Ahmed rule of thumb: $8 \text{ gpd}/\text{ton} \times 727 \text{ ton} = 5,816 \text{ gpd} = 4.0 \text{ gpm}$

¹ For example, EnergyPlus is a free building energy modeling software provided by the Department of Energy (DOE), which outputs a parameter called “Cooling Coil Condensate Volumetric Flow Rate.”

SAWS rule of thumb: $0.5 \text{ gph}/1,000 \text{ sq ft} \times 154,440 \text{ sq ft} = 77 \text{ gph} = 1.3 \text{ gpm}$

to $0.6 \text{ gph}/1,000 \text{ sq ft} \times 154,440 \text{ sq ft} = 93 \text{ gph} = 1.5 \text{ gpm}$

SAWS rule of thumb: $0.1 \text{ gph}/\text{ton} \times 727 \text{ ton} = 73 \text{ gph} = 1.2 \text{ gpm}$

to $0.3 \text{ gph}/\text{ton} \times 727 \text{ ton} = 218 \text{ gph} = 3.6 \text{ gpm}$

Recall that the SAWS rules of thumb are applicable during the summer months (June through August) and the Bryant and Ahmed estimate is applicable during the longer cooling season (May through September). So we can expect the condensate exiting the AHU to be somewhere between 1.1 and 4.0 gpm during the cooling season for this 727-ton system. The low end of the AWE rule of thumb was intentionally excluded from the expected range because it is not specified as peak cooling season. Less condensate is produced during the cooler months with lower humidity.

Example 7.2 The monthly measured values of condensate for the AET building for the year 2011 can be compared against the rule-of-thumb values from Example 7.1 by multiplying the condensate rate values in units of gpm from Example 7.1 by 1,440 minutes per day times the number of days in each month. The resulting estimates are shown in Figure 7.1.

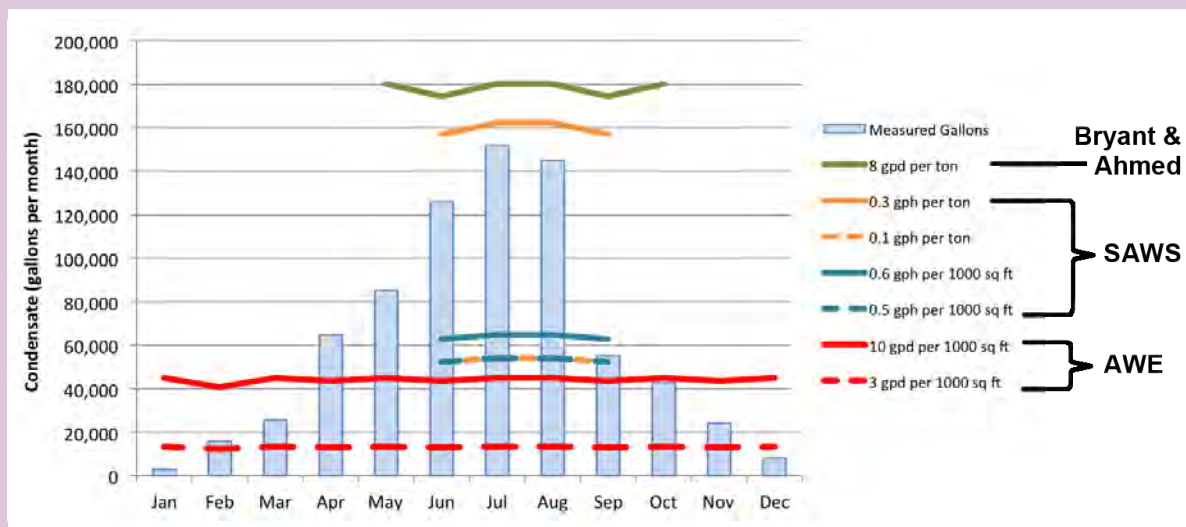

Figure 7.1 Comparison of rule-of-thumb values with measured results for the AET Building

The 0.1 and 0.3 gph per ton estimates envelope the actual performance during summer months. SAWS uses 0.2 gph per ton as an estimate of nominal condensate production to calculate annual condensate production for rebate awards (San Antonio Water System 2012). The 0.5 and 0.6 gph per 1,000 square feet and the 10 gpd per 1,000 square feet estimates are low in this example for summer months because these rules of thumb are based on “typical” commercial buildings, and the AET building requires higher-than-usual cooling capacity per square foot to support the education and research functions within. So all three rule-of-thumb estimates based on square footage, as a proxy for cooling load, are expectably low for this example. The estimate of 8 gallons per day per ton is at the upper limit. Although plots of measured values of monthly condensate for this and other buildings are expected to vary year to year, all plots show similar trends: the most condensate is produced in the summer between June and August, and limited condensate is produced during the winter.

An estimate by Lawrence et al. for annual condensate collected in a San Antonio building is 19.0 gallons per cubic foot per minute (cfm) of outdoor airflow through the AHU based on weather data, and 17.1 gallons based on a regression equation using a variety of meteorological parameters (Lawrence et al. 2012).

Water-Carrying Capacity of Air

All approaches related to predicting the instantaneous condensate rate are based on a fundamental mass balance equation describing the difference between the amount of water carried by the air entering the AHU and the amount of water carried by the lower-temperature air exiting the unit (Painter 2009; Lawrence et al. 2010; American Society of Heating, Refrigerating, and Air-Conditioning Engineers 2009; Trent et al. 1998). The reason moisture leaves the air as it passes through the AHU is that the water-carrying capacity (also known as the water vapor capacity) of air decreases as air dry bulb temperature decreases, as shown in Figure 7.2. As the temperature decreases through the AHU, the moisture that the air can no longer carry collects on the cooling coils in the form of condensate and drips into the drain pan.

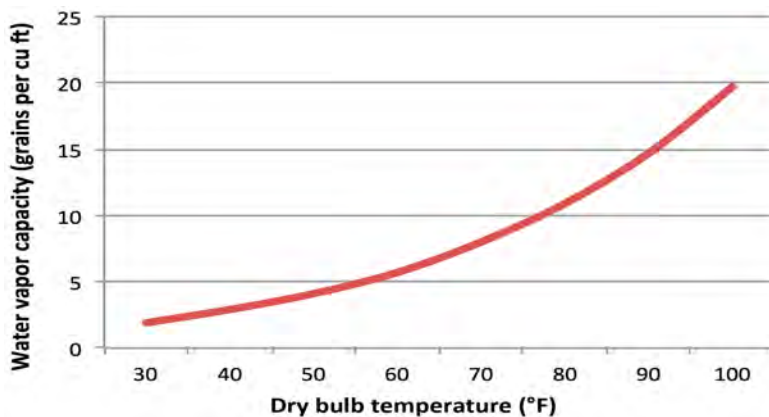

Figure 7.2 Water-carrying capacity of air as a function of air temperature, at atmospheric pressure

Once one knows the condition of the air entering the AHU (outdoor and return air in Figure 1.2) and exiting the AHU (supply air in Figure 1.2), one can predict the expected amount of condensate produced per pound mass of air passing through the AHU per time. This prediction is achieved using either a psychometric chart or thermodynamic equations of state, in conjunction with the mass balance equation. Numeric answers will vary slightly based on the reference source used to obtain the thermodynamic values.

Instantaneous Condensate Flow Rate

Since the air passing through the AHU originates from two sources, outside air and return air (see Chapter 1), condensate originating from moisture in each air source must be considered when calculating total condensate flow rate (Q_{ct}). This can be done by treating each airstream separately and then adding the results, as depicted in Equation 7.1. Condensate generated from outside air and return air are represented by Q_{co} and Q_{cr} , respectively. An alternative approach, which treats the combined airstream as mixed air, is presented in the *ASHRAE Fundamentals Handbook* (2009).

Equation 7.1

$$Q_{ct} = Q_{co} + Q_{cr}$$

Psychrometric calculating tools are available for download free from the Internet.² These tools are more accurate than the simplified equations presented in this chapter. However, these tools only provide a condensate flow rate at a single AHU inlet and outlet condition, whereas the equations presented in this chapter can be used in a spreadsheet to calculate condensate over time as conditions change, thereby facilitating calculations of monthly and annual production.

Instantaneous condensate flow rate generated from moisture in outside air

In hot and humid climates, like San Antonio, the condensate generated from outside air is typically much more than that from return air in almost all building types (Harriman and Lstiburek 2009).³ SAWS developed an equation to estimate condensate flow rate generated from outside air (Q_{co}) using the mathematical description of the curve in Figure 7.2 as the requisite thermodynamic equation of state (Wilcut and Fry 2010). A modified version of this equation is shown in Equation 7.2.

Equation 7.2

$$Q_{co} = Q_{air} \times OA \times \left[\frac{(RHo(.0033To^2 - .1823To + 4.703)) - (RHs(.0033Ts^2 - .1823Ts + 4.703))}{58310} \right]$$

Equation 7.2 can be used to estimate instantaneous condensate production generated from outside air (Q_{co}) in units of gallons per minute (gpm) given the temperature and relative humidity of the outside air entering (T_o and RHo) and supply air exiting the AHU (T_s and RHs) along with the airflow (Q_{air}) through the AHU in units of cubic feet per minute (cfm) and the percentage of outside air (OA) entering the AHU. The relative humidity and percentage of outside air are represented by decimal values between 0 and 1, while the temperatures are represented in degrees Fahrenheit. In the absence of specific operating information, a supply air condition of 55°F and 94% RH immediately downstream of the cooling coil can be assumed as representative.⁴ This condition corresponds to a dew point of 53°F, which falls below the recommended upper limit of 55°F in order to avoid mold risk and optimize occupant comfort (Harriman and Lstiburek 2009).

Example 7.3 Assume that airflow (Q_{air}) through an AHU is 100,000 cfm, with 60% outside air (OA). The remainder of the air is return air from the conditioned space. If the outside temperature (T_o) and relative humidity (RHo) are 83°F and 67%, and the supply air temperature (T_s) and relative humidity (RHs) are 55°F and 94%, then Equation 7.2 predicts the instantaneous condensate flow rate from moisture in the outside air (Q_{co}) to be 3.98 gpm.

Instantaneous condensate flow rate generated from moisture in return air

The amount of moisture in return air varies drastically depending on the design, construction, and use of the building. These particulars of the building are considered when calculating the cooling load for design of the building's HVAC system. Detailed cooling load calculations are beyond the scope of this manual.

Three common approaches to obtain rough estimates of condensate from the moisture generated in the conditioned space (Q_{cr}) are presented here. The choice of which method to use in estimating Q_{cr} depends on which inputs are known or can be realistically assumed. Estimated values of

² Munters Incorporated offers a well-established tool called "Munters PsychoApp" that accepts properties from two different airstreams and computes the properties of the resulting mixed airstream as well as the moisture-carrying capacity (in terms of humidity ratio) of the airstream entering and exiting an AHU. This enables calculation of condensate generated in the process. <www.munters.us/psychtools>

³ Exceptions are buildings such as natatoriums, where water evaporation increases humidity, and event centers, where a high density of active people constantly introduce moisture into the space through respiration and perspiration.

⁴ The representative supply air condition varies among literature sources. Most assume a supply temperature of 55-57°F with a humidity ratio in the range of 85-100% (Painter 2009; Lawrence et al. 2010; Trent et al. 1998). Therefore, 55% and 94% is within the published assumed range.

Q_{cr} can be combined with estimated values of condensate from outside air (Q_{co}) to estimate total condensate production (Q_{ct}).

Assume an “adjusted” supply air condition

Since the condensate generated from outside air is typically much more than that from return air in hot and humid climates, Equation 7.2 is sometimes used alone to approximate total condensate (Q_{ct}). For this approach, the supply air condition in the equations is often decreased (e.g., to 53°F and 94% relative humidity) to account for cooling of the relatively small amount of moisture encountered in the conditioned space.

Example 7.4 Assuming the same parameters as Example 7.3 and using Equation 7.2 with an adjusted supply air condition of 53°F and 94% relative humidity, the total condensate (Q_{ct}) is estimated to be approximately 4.31 gpm. This result implies that this adjusted supply air condition accommodates about 0.34 gpm of moisture generated in the conditioned space.

Dedicated outside air systems (DOAS) drawing 100% outside air are commonly used in conjunction with separate AHUs inside the building, whereby the supply air of the DOAS is set at a low enough temperature and humidity value to accommodate moisture encountered in the conditioned space so that the separate AHUs located inside the building produce little to no condensate.

Assume return air conditions

Alternatively, condensate flow rate from return air (Q_{cr}) can be computed directly by replacing the percentage of outside air (OA) by the percentage of return air (1-OA) in thermodynamic Equation 7.2 and by replacing the outside air values by return air values. The resulting equation is Equation 7.3, in which the relative humidity and percentage of return air are represented by decimal values between 0 and 1, while the temperatures are represented in degrees Fahrenheit. Q_{air} is in cubic feet per minute. This approach requires knowledge of the expected return air conditions with some accuracy.

Equation 7.3

$$Q_{cr} = Q_{air} \times (1-OA) \times \left[\frac{(RH_r(.0033T_r^2 - .1823T_r + 4.703)) - (RH_s(.0033T_s^2 - .1823T_s + 4.703))}{58310} \right]$$

Example 7.5 Assuming that the return air in Example 7.3 is at 76°F and 50% relative humidity, Equation 7.3 applied to the same airflow and supply air conditions as Example 7.3 with 60% outside air (OA) results in additional condensate production from return air (Q_{cr}) of 0.39 gpm. This is much less than the 3.98 gpm condensate originating from outside air (Q_{co}) calculated in Example 7.3. The relative amounts of condensate produced depend on the temperature and relative humidity of the return versus the outside air as well as the percentage of outside air passing through the AHU. The total condensate (Q_{ct}) estimated by adding the condensate calculated from outside and return air is 4.37 gpm.

Account for humidity load sources directly

Another alternative for calculating moisture in the return air is to estimate the rate of moisture produced within the conditioned space and assume this moisture is constantly removed at the same rate it is produced. The moisture removed from the conditioned space is referred to in terms of latent heat or humidity load. Using this method to calculate Q_{cr} requires detailed knowledge of the building envelope (i.e., building enclosure separating the inside and outside environment) and expected building usage.

In most cases this added moisture in the conditioned space is primarily from outside air infiltrating, or leaking, into the building. The degree to which a wall “leaks” air depends on its design, its construction, and the pressure differential from the inside to outside of the wall. The *ASHRAE Guide for Building in Hot and Humid Climates* (2009) shows representative buildings in Tampa, Florida, to incur anywhere from about 5% to 30% infiltration as compared to the ventilation air. One would expect San Antonio infiltration to be about the same.

Infiltration is “notoriously difficult to predict with any accuracy” because it varies with time and location within the building (Harriman and Lstiburek 2009). Analysis of infiltration is beyond the scope of this manual. Therefore, infiltration values will be assumed to enable calculations for example problems presented herein. Please consult ASHRAE resources such as the *ASHRAE Guide for Buildings in Hot and Humid Climates* (2009) and the *Humidity Control Design Guide for Commercial and Institutional Buildings* (2001) for additional information.

The second most significant source of moisture found in conditioned space is typically people. Moisture from human respiration, perspiration, and evaporation of moisture from clothing all contribute to the humidity load. For buildings with densely occupied spaces, such as gambling casinos and movie theaters, people can be the primary source of moisture, superseding infiltration (Harriman and Lstiburek 2009).

Other lesser sources of moisture are plants, wet surfaces, domestic loads, and opening doors (Harriman and Lstiburek 2009). Examples of humidity load sources from people are listed in Table 7.1. Computers, lights, manufacturing equipment, and human body heat all increase the temperature of the conditioned space. However, temperature increases do not increase the moisture content, only the water-carrying capacity of the air, as shown in Figure 7.2.

Table 7.1 Humidity loads from occupants (Source: adapted from Harriman and Lstiburek 2009^a)

Activity	Typical of	Load per Person (lb/hr) ^b
Seated, at rest	Theater patron	0.1
Seated, very light work	Hotel or restaurant patron	0.15
Seated, moderately active	Offices, retail cashier	0.19
Standing, light work, walking	Offices, retail patron	0.19
Walking, standing	Offices, retail floor clerk	0.24
Seated, light work	Electronic assemblers	0.45
Moderate dancing	Dancing, nursing care	0.52
Walking briskly with loads	Restaurant servers	0.6
Light exercise	Bowling, slow treadmill	0.83
Heavy work with lifting	Factory, health club machines	0.92
Athletics	Basketball, heavy exercise	1.04

^a Reprinted with permission from ©ASHRAE *Guide for Building in Hot and Humid Climates* ^b Conversion factor: 1 gallon = 8.34 lb

Plants and animals occupying space also introduce a humidity load. For example, a medium-sized houseplant transpires about 0.57 lbs water per day, which is equal to about 10% the humidity load of a seated person at rest (Harriman and Lstiburek 2009). The humidity load from these sources is likely minor unless the commercial building includes many plants, such as in an atrium, or animals, such as in a veterinary clinic.

Events occurring within the conditioned space also contribute to the humidity load. Common domestic sources of humidity load are listed in Table 7.2 for reference. More data can be found in

the *ASHRAE Handbook—Fundamentals* (2009) and other sources addressing cooling load calculations.

Table 7.2 Domestic humidity load events (Source: adapted from Harriman and Lstiburek 2009^a)

Event	Typical Duration (min)	Load per Event (lb) ^b
Bath	15	0.12
Shower	15	1.4
Meal preparation	20–40	.35–1.58
Washing dishes	10	.07–.68
Simmering pot (6" diameter)	10	0.13
Boiling pot (6" diameter)	10	0.57
Floor drying after mopping	60	0.03

^a Reprinted with permission from ©ASHRAE Guide for Buildings in Hot & Humid Climates

^b Conversion factor: 1 gallon = 8.34 lb

Example 7.6 Determining the moisture removed from return air in Example 7.3 using the “account for humidity load sources directly” approach requires knowledge of the building envelope and usage. Assuming the infiltration air is estimated or calculated to equal about 6% of the ventilation airflow, the infiltration air contributes about 0.239 gpm to the humidity load. If an average of 700 people perform office work in the building from 9 to 5 p.m. each weekday, another 133 lbs per hour (0.266 gpm) of condensate are generated between 9 and 5 p.m. weekdays. So during the workday the humidity load from people (0.266 gpm) is slightly higher than that from infiltration (0.239 gpm). However, over a week’s time, 2,400 gallons are produced from infiltration, while only 638 gallons are expected to be produced from people. The fact that infiltration occurs all the time while people and events only add humidity load intermittently is the main reason infiltration is typically the primary source of humidity load in buildings.

Simplifying Assumptions and Estimates for Constant Volume Systems

Several common assumptions and estimates are discussed in this section for constant volume air-conditioning systems. Variable volume systems require a slightly different approach that considers changes in airflow rate.

Estimating airflow rate

The airflow rate (Q_{air}) through a constant volume air-conditioning system is expected to remain constant for all cooling loads. Its value is dictated by the design of the system. The fact that direct measure of the airflow rate (Q_{air}) during normal operation is not common practice, along with the fact that modifications in the flow path can pull the airflow off its design condition, necessitates the use of an assumed or estimated value for Q_{air} to predict condensate rates using Equations 7.1-7.3

Wilcut and Fry (2010) propose an estimate of the air flow rate based on the base airflow rate (Q_{base}) in units of cfm per ton and the total cooling capacity of the air-conditioning unit (TONS) in units of tons as shown in Equation 7.4.⁵ For reference, base airflow rates are often on the order of 300 to 450 cfm per ton cooling capacity.

⁵ The total capacity is the sum of the latent capacity (i.e., ability to remove moisture from the air) and sensible capacity (i.e., ability to reduce the dry-bulb temperature). Tonnage is a measure that relates a system’s cooling capacity to the equivalent cooling effect of melting ice. For example, a system rated at 3 tons can produce the same amount of cold air as melting 3 tons of ice per hour.

Equation 7.4

$$Q_{air} = Q_{base} \times TONS$$

They also account for the fact that the cooling of the air flowing through the AHU does not always operate at full capacity and depends on cooling load. They do this by introducing a factor with a decimal value between 0 and 1, which is labeled percent of total capacity (OC). For variable volume systems, OC includes consideration of changes in air flow rate in addition to cooling of the air.

Substituting the estimate from Equation 7.4 into Equations 7.2 and 7.3 and multiplying by the percent total capacity (OC) creates Equations 7.5 and 7.6, respectively.

Equation 7.5

$$Q_{co} = Q_{base} \times TONS \times OC \times OA \times \left[\frac{(RHo(.0033To^2 - .1823To + 4.703)) - (RHs(.0033Ts^2 - .1823Ts + 4.703))}{58310} \right]$$

Equation 7.6

$$Q_{cr} = Q_{base} \times TONS \times OC \times (1-OA) \times \left[\frac{(RHR(.0033Tr^2 - .1823Tr + 4.703)) - (RHs(.0033Ts^2 - .1823Ts + 4.703))}{58310} \right]$$

Example 7.7 Assume a base airflow rate of 350 cfm and operation at 50% total capacity for a 600-ton cooling capacity air-conditioning unit drawing 30% outside air. If the outside temperature (T_o) and relative humidity (RHo) are 89°F and 43%, and the supply air temperature (T_s) and relative humidity (RHs) are 55°F and 94%, then the instantaneous condensate flow rate generated from outside air (Q_{co}) calculated by Equation 7.5 is 1.03 gpm.

The condensate attributed to humidity load inside the occupied space can be calculated by applying one of the three approaches presented in this chapter, as follows:

Using the “assume an adjusted supply air condition” approach to estimate the total amount of condensate (Q_{ct}), the condensate rate is calculated with adjusted supply air values of 53°F and 94% relative humidity. The resulting amount of total condensate is estimated from Equation 7.5 to be 1.21 gpm.

Using the “assume return air conditions” approach to calculate the condensate generated from return air (Q_{cr}) with assumed return air conditions of 76°F and 50% relative humidity, the Q_{cr} from Equation 7.6 is 0.72 gpm. Total estimated condensate (Q_{ct}) is 1.75 gpm.

Using the “account for humidity load sources directly” approach to estimate the moisture generated in the conditioned space requires knowledge of the building use. Assuming the infiltration air is estimated or calculated to be 20% of the ventilation air, the infiltration air is 0.20 gpm. Assume the building holds 1,500 moderately active people at the associated humidity load from Table 7.1 of 0.19 lb per hour per person equating to 285 lb per hour (0.57 gpm). If the building includes a small atrium in the lobby with plants that produce another 850 lb per day (0.07 gpm), Q_{ct} is calculated to be 1.30 gpm for the building when it is empty and 1.87 gpm when it is occupied. As illustrated by this example, humidity load changes during the day, making a humidity load schedule useful for more complex calculations.

The total condensate calculated for this example from the three different methods presented in this chapter ranges from 1.21 to 1.87 gpm. These estimates are rough estimates intended to provide order-of-magnitude results for the condensate rate to facilitate design decision. The accuracy of each method depends on how good the assumptions are for that method.

Supply air temperature and humidity

The supply air temperature and humidity is different during the heating and cooling season. For existing buildings, consult facility personnel for the actual values. For new buildings in San Antonio, for simplicity, estimated values of 55°F and 94% relative humidity, representative of the cooling season,⁶ can be used as the year-round supply air condition for condensate calculations. The resulting error during heating season (i.e., winter) is expected to be minimal, since the limited times during the heating season that the air will be cooled and produce condensate are minimal.

Be mindful that calculating condensate from outside air during the heating season using Equations 7.2 and 7.5 will result in a negative number. This means that moisture would actually need to be added to the dry cool outdoor air to achieve the desired supply air condition. Therefore, condensate is not produced and the negative values are treated as zeros when interpreting the calculated results. If moisture is added during the heating months, it is added using a humidification system.

Estimates for return air temperature and humidity

For existing buildings, consult with facility personnel for expected return air temperatures. For a future commercial building in San Antonio, the estimated values of 76–80°F and 50% relative humidity can be employed for rough calculations of Q_{cr} . The actual relative humidity will depend on the activities occurring in the conditioned space. For example, if the space supports activities such as cooking in a culinary school or showering in a military barracks, the relative humidity is expected to be higher.

Condensate over Time

Calculating condensate over time provides the expected amount of condensate water available for proposed applications, such as cooling tower makeup water, toilet flushing, or irrigation. Applying Equations 7.1–7.6, or comparable thermodynamic equations of state or psychrometric charts, to hourly values of T_o and RH_o with assumed operating conditions gives the typical condensate rate for each hour. This rate during each hour can be multiplied by the appropriate time units in an hour to obtain the volume of water collected during that hour.

For example, if the typical condensate rate during a given hour is determined to be 3.22 gpm, then multiplying this value by 60 minutes gives a condensate volume of 193 gallons for that hour. The condensate produced for each specific hour can be added to compute the condensate for that specific day. Likewise, the condensate per day values can be added to compute the condensate per month. The use of an electronic spreadsheet facilitates computations based on the 8,760 hourly data entries for a one-year time period. Building energy models use the same principle, but apply more sophisticated equations and correlations beyond the scope of this manual.

Recorded hourly values for T_o and RH_o can be obtained online from the National Oceanic and Atmospheric Administration (NOAA) National Climate Data Center (NCDC). However, for predictions, expected future values must be used instead of recorded. Typical hourly values for meteorological parameters can be obtained online for 1,020 locations from the Typical Meteorological Year (TMY) database.⁷ Similarly, average hourly, daily, monthly, seasonal, or annual values for T_o

⁶ The representative supply air condition varies among literature sources. Most assume a supply temperature of 55–57°F with a humidity ratio in the range of 85–100% (Painter 2009; Lawrence et al. 2010; Trent et al. 1998). So 55% and 94% is within the published assumed range and corresponds to a dew point of 53°F, which falls below the recommended upper limit of 55°F in order to avoid mold risk and optimize occupant comfort (Harriman and Lstiburek 2009).

⁷ The Typical Meteorological Year database (TMY2 and the more recent TMY3) provides hourly meteorological values that typify climatic conditions for a specific location based on data collected over a long time period. The National Renewable Energy Laboratory (NREL) determined the typical values based on simultaneously considering five critical weather parameters. For the San Antonio International Airport, the typical values are based on years 1976 to 2005. Therefore, the resulting set of typical values for each hour does not provide the average value of any single weather parameter; rather, it provides the statistically typical values for the set of parameters (NREL 2012).

and R_{ho} can be obtained from the NCDC database.⁸ All climate data used for calculations in this manual were recorded at the San Antonio International Airport.

Beware of using average monthly values of T_o and R_{ho} to compute monthly condensate production, because this produces misleading results. This is an artifact of average monthly values not providing true coincident conditions of temperature and humidity during the month.

Expected hourly values for T_s , R_{Hs} , T_r , R_{Hr} , Q_{air} , and OC are building specific and must be assigned by someone who knows the site's operations and HVAC systems. The nominal percent of total capacity (OC) depends on specific building factors, such as how the AHU was sized (e.g., smaller units will run longer, raising the nominal percent total capacity over time) and whether supply air setback temperatures and humidities are used when the building is not occupied.

Q_{air} , or alternatively Q_{base} , and OC are the most challenging variables to assign or model, since these parameters can vary with the temperature and humidity load on the building. Q_{air} and Q_{base} are not commonly measured. However, OC can be correlated with the power demand of the AHU. Inaccuracies in Q_{air} , Q_{base} , and OC are typically the primary cause of inaccuracy in calculated condensate production. Similarly, inaccurate assumptions influencing any input parameters to the condensate production calculations lead to errors. Therefore, it is important to be mindful of assumptions when interpreting results.

Typical monthly condensate potential (maximum) from outside air

A plot of monthly condensate potential for a representative building in San Antonio is shown in Figure 7.3. The term *potential* is used to indicate the maximum amount of condensate that could be produced if the system were to run with 100% outside air at full capacity (i.e., OC is 100%) for 24 hours a day, 7 days a week, for the entire year. Although a gross overestimate of actual condensate expected under normal building operation conditions, this information provides an upper limit and order of magnitude information.

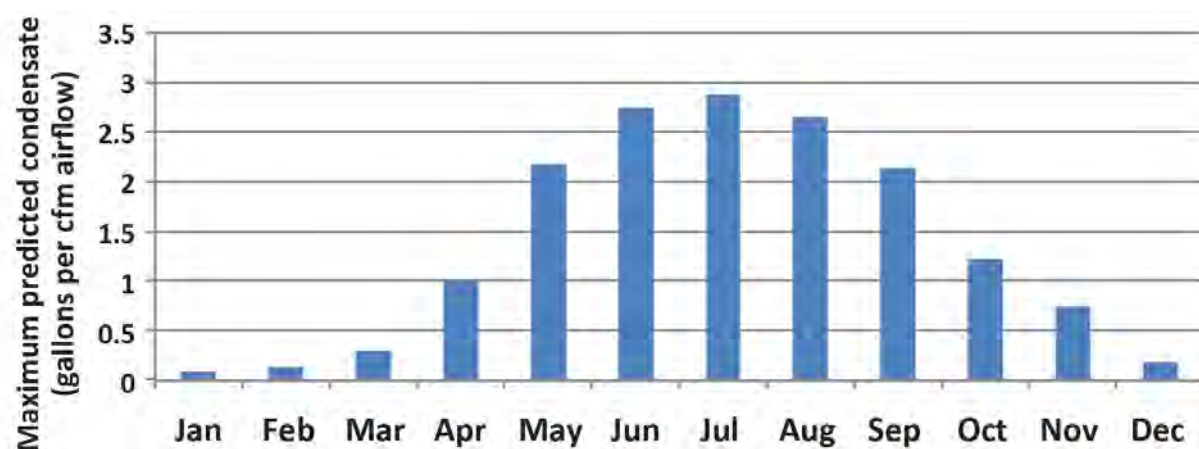

Figure 7.3 Predicted condensate production per cfm airflow of 100% outside air entering an AHU in San Antonio with supply temperature and relative humidity of 55°F and 94%

The plot in Figure 7.3 was generated using hourly outside air conditions (T_o , R_{ho}) from the TMY3⁷ database along with an assumed supply air condition (T_s , R_{Hs}) of 55°F and 94% relative humidity using 100% outside air (OA). An electronic spreadsheet facilitated computations based on the 8,760 hourly data entries for a one-year time period. The information in Figure 7.3 is presented in tabular form in Appendix D.

⁸ Average values reported by the National Climate Data Center are based on data from 1981 to 2010 (NOAA 2012).

Figure 7.3 shows the most condensate to occur between June and August and the least condensate to occur between December and January, as expected.

Figure 7.4 presents the same data as in Figure 7.3, but as a function of cooling capacity rather than airflow. This representation of the data requires one to assume a correlation between base airflow (Q_{base}) and cooling capacity, which for Figure 7.4 is 350 cfm per ton total cooling capacity in accordance with Wilcut and Fry (2010).

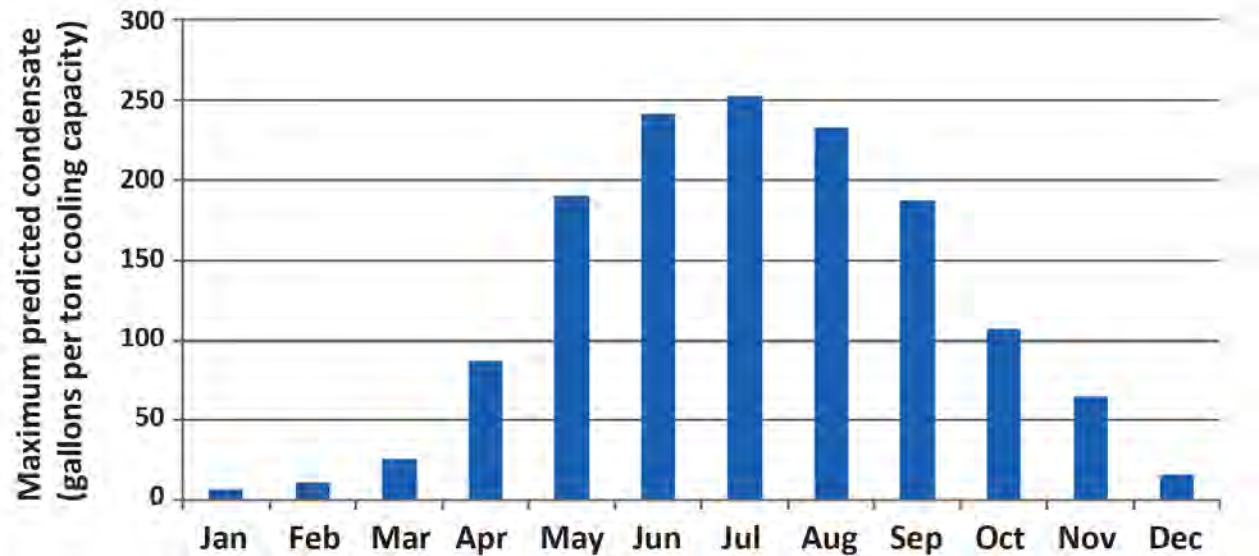

Figure 7.4 Predicted condensate production per ton cooling capacity per month for 100% outside air entering an AHU operating at 100% of total capacity in San Antonio with supply air temperature 55 °F and relative humidity of 94% with an assumed air flow rate of 350 cfm per ton cooling capacity

The actual percentage of total capacity at which a system operates, and the resulting condensate generated, varies with time and depends on the cooling load. Example 7.8 demonstrates that the subsequent actual generation of condensate, as measured by a water meter placed in the condensate drain line, can be significantly less than the calculated potential.

The condensate potential tables in Appendix D can be used to estimate monthly potential production of condensate generated from moisture in outside air. Table D.1 can be used with an assumed nominal continuous airflow rate (Q_{air}), and Table D.2 can be used with an assumed base airflow rate (Q_{base}), tons of cooling capacity (TONS), and a nominal percent of total capacity (OC). Obviously, the accuracy of the results depends on how closely the assumptions used to generate Table D.1 and Table D.2 match the actual operating conditions of the building being considered.

Example 7.8 The 267,000 square feet of conditioned space in the Maxim Integrated Products⁹ building in San Antonio are cooled by multiple AHUs with a total cooling capacity (TONS) of 2,400 tons. The AHUs draw 100% outside air (OA) and operate 7 days a week, 24 hours a day, to support the functions within. The columns in Figure 7.5 show the measured condensate from 2009 through 2012. The drastic variation from year to year demonstrates how condensate production varies based on actual temperature and humidity conditions, building operating conditions, and usage.

⁹ Maxim Integrated Products designs, develops, and manufactures electronics at its San Antonio location. The large tonnage per square foot of conditioned space supports the manufacturing processes within the building.

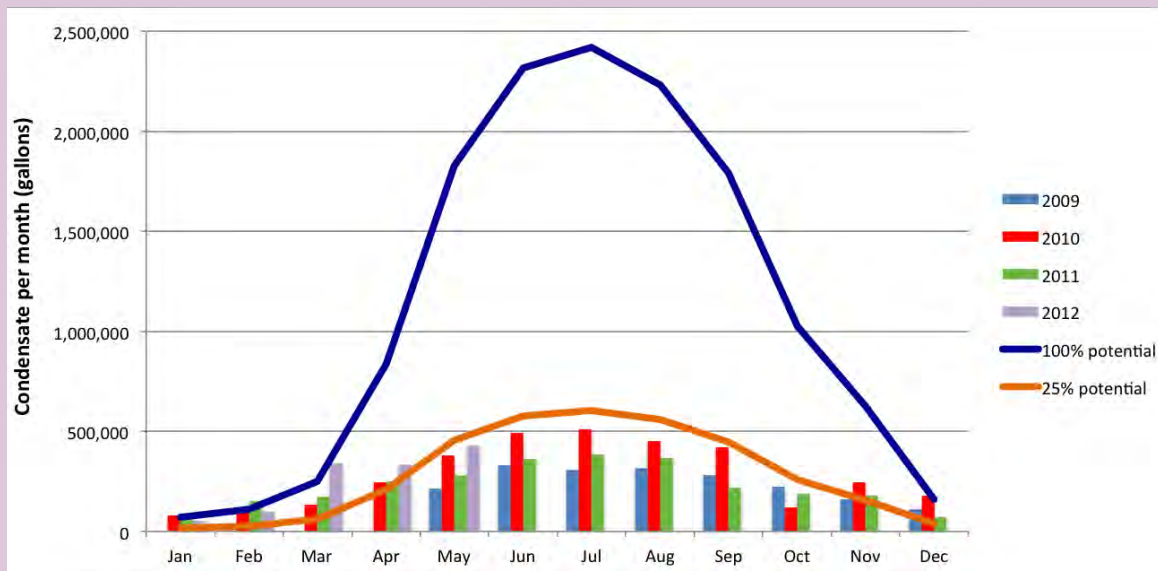

Figure 7.5 Measured and estimated condensate produced per month in the Maxim building

The predicted potential (maximum) condensate per month based on assumptions used to generate Figure 7.4, namely 350 cfm per ton (Q_{base}), supply air temperature 55°F and relative humidity of 94%, 100% outside air and an operating at 100% total capacity (OC) applied to the known cooling capacity of 2,400, is several times more than the actual measured condensate as shown by the upper curve on Figure 7.5. Table D.2 in Appendix D was used to estimate the potential (maximum) amount of condensate each month by multiplying the 10th column of data in Table D.2, which corresponds to gallons of condensate produced per 1,000 tons, by 2.4. The reason for the difference between the measured amount of condensate and the predicted potential (maximum) is primarily that the building does not operate at 100% capacity all the time. Buildings operate at the percent total capacity needed to meet the varying temperature and humidity loads (i.e., cooling loads) on the building.

An assumed operation at a nominal 25% of total capacity (OC) is a much closer estimate of condensate production for this building (as shown by the lower curve on Figure 7.5) and several other buildings in San Antonio for which measured data were analyzed.¹⁰ The lower curve was calculated by multiplying the monthly results obtained for 100% of total capacity, as outlined above, by 0.25 to achieve the value for operation at 25% of total capacity (OC).

Building energy models use detailed building operation information to model the cooling demand, and resulting load, as a function of time, thereby eliminating the need to “guess” a relevant nominal percent of total capacity (OC) to estimate condensate. This is the primary reason building energy models provide more accuracy than the rough estimates presented in this manual.

Nonetheless, using the equations and tables provided herein with an educated “guess” does provide a time-dependent condensate estimate somewhere below the potential maximum value (i.e., operating at 100%), which is more useful information than the rules of thumb in preparing a monthly water budget.

¹⁰The author, Diana Glawe, is currently collecting data from condensate meters in commercial buildings to derive “intelligent defaults” and refine simple estimates based on different types of buildings in San Antonio. If you have data to contribute, please send to conserve@saws.org

Monthly condensate quantity from inside air

For AHUs that draw less than 100% outside air, predictions of estimated monthly condensate from moisture generated in the conditioned space (Q_{cr}) can be estimated from any of the three alternatives presented in this chapter and added to the condensate from the outside air (Q_{co}). Example 7.9 uses the “assume return air conditions” approach to illustrate this process.

Example 7.9 Assume the building operating conditions in Examples 7.3 and 7.5 represent nominal values for the building throughout the year, repeated here for easy reference: Q_{air} is 100,000 cfm, OA = 60%, $T_s = 55^\circ\text{F}$, $RH_s = 94\%$, $T_r = 76^\circ\text{F}$, and $RH_r = 50\%$. To calculate the amount of condensate generated per month, two calculations are conducted: one for the outside air and one for the return air.

The first calculation is similar to Example 7.8, where the condensate per month is computed by multiplying column 4 in Table D.1 by a factor of 0.6 to account for the fact that only 60% of the airflow comes from outside. This generates the values of Q_{co} in column 2 of Table 7.3.

The second calculation accounts for the moisture extracted from the 40% return air. We can use Equation 7.6 with the return air temperature of 76°F and 50% relative humidity to calculate continuous condensate flow (Q_{cr}) of the moisture in the return air in gallons per minute to be 0.394. We multiply this value by 1,440 minutes in a day and then by the days in the month. The resulting predicted gallons for each month from return air are shown in column 3 of Table 7.3. The total predicted condensate shown in column 4 of Table 7.3 is the sum of the predicted condensate from outside and return air combined.

Table 7.3 Predicted condensate production for Example 7.7 from outside and return airflow through the AHU

Month	Predicted Condensate from Outside Air (Q_{co}) (gallons)	Predicted Condensate from Return Air (Q_{cr}) (gallons)	Predicted Total Condensate (Q_{ct}) (gallons)
Jan	4,917	17,609	22,527
Feb	7,800	15,905	23,705
Mar	17,932	17,609	35,541
Apr	59,773	17,041	76,814
May	130,505	17,609	148,114
Jun	165,336	17,041	182,377
Jul	172,952	17,609	190,561
Aug	159,537	17,609	177,146
Sep	128,106	17,041	145,147
Oct	73,331	17,609	90,940
Nov	44,621	17,041	61,662
Dec	11,284	17,609	28,893
Annual	976,093	207,334	1,183,427

Table 7.3 illustrates how during the winter months, when the outside air is cool and dry, the primary source of condensate is the moisture generated in the conditioned space by people, activities, and processes within the building.

Building a Water Budget

A water budget analysis can be used to determine the water surplus or shortfall provided by the condensate water for a given application's water demand. Since the amount of condensate produced varies over time with seasonal temperature and humidity conditions, as does water demand for some applications, it is practical to create a water budget using monthly intervals. Intervals can be broken down further, by day or hour if desired, but monthly intervals are typically precise enough for design purposes.

Unless the condensate water is used as makeup water in a cooling tower or other process that will always use more water than produced, a storage tank can capture the excess water to be used later. The size of the storage tank dictates how much of the water is collected for use versus discharged as overflow. The water budget helps to determine the best application and right size tank for the selected application of the condensate water, as illustrated by Example 7.10.

Example 7.10 In San Antonio, Texas, multiple AHUs with a total cooling capacity of 420 tons are used to cool 110,000 square feet of conditioned office space, per ASHRAE design guidelines (American Society of Heating, Refrigerating, and Air-Conditioning Engineers 2005). The AHU draws 100% outside air (OA) with a supply air condition (T_s , RHs) around 55°F and 94% relative humidity. Assuming operation at nominal 25% of total operating capacity (OC), the amount of condensate produced per month can be predicted using the estimated condensate rate for 100 tons (from column 5 of Table D.2 in Appendix D) multiplied by 4.2 to account for 420 tons and 0.25 to count for 25% total capacity. The result is shown in column 2 of Table 7.4. The estimated annual condensate is 597,875 gallons.

Table 7.4 Water budget for condensate collection and use for Examples 7.10 and 7.11

Month	Condensate Supply (Q_C) (gallons)	Toilet Flushing Demand (Q_D) (gallons)	Cumulative Excess Condensate after Toilet Flushing (gallons)	Rainwater Supply (gallons)
May	79,934	70,380	9,554	137,133
Jun	101,268	64,260	46,562	140,562
Jul	105,933	67,320	85,175	92,565
Aug	97,717	70,380	112,511	71,995
Sep	78,465	61,200	129,776	102,850
Oct	44,915	70,380	104,312	140,562
Nov	27,330	67,320	64,322	78,852
Dec	6,911	64,260	6,973	65,138
Jan	3,012	67,320	-57,335	61,710
Feb	4,778	64,260	-116,817	61,710
Mar	10,983	67,320	-173,154	78,852
Apr	36,611	64,260	-200,803	71,995
Annual	597,857	798,660	NA^a	1,103,923

^a NA = not applicable

If the condensate is used as makeup water for a cooling tower, no storage tank is required because the condensate rate is less than 45% of the required makeup water for even the most highly ventilated buildings (Sieber 2010). Furthermore, no additional treatment beyond the existing cooling

tower water treatment is needed, and the additional piping and accessories are of minimal cost. This offers the highest return on investment and is the recommended application for condensate when a cooling tower is present.

However, if routing the condensate to a cooling tower is not feasible, the monthly estimates of condensate generation can be compared to the monthly demand of different applications of the reclaimed water, such as toilet flushing, water features, and irrigation. This comparison is called a water budget. The water budget assists in selecting the optimal application for the condensate and other on-site reclaimed water sources.

Example 7.11 If condensate is used for water closet and urinal flushing, and the 110,000-square-foot office building supports 1,000 full-time employees (FTEs), assume 500 male (n_m) and 500 female (n_f), during the weekdays only, then the weekday water demand would be based on the estimated number of flushes per person (3 water closet flushes per female FTE [f_{tf}] and 1 water closet [f_{tm}] plus 2 urinal flushes [f_u] per male FTE) per day (US Green Building Council 2009). If the toilets meet the EPA WaterSense standards for flush volume for low-flow toilets (q_t) of 1.28 gallons and (q_u) urinals of 0.5 gallons, the water demand (Q_D) is calculated using Equation 7.7 (Environmental Protection Agency 2008).

Equation 7.7

$$Q_D = q_t \times (n_f \times f_{tf} + n_m \times f_{tm}) + q_u \times n_m \times f_u$$

The result is that 2,810 gallons of water are required, on average, for water closet and urinal flushing in the building each weekday. This is multiplied by the number of weekdays per month to compute the demand for water in gallons per month shown in Table 7.4.

Supply meets demand for only 5 of 12 months (May–Sep). If excess condensate water during these months were discharged to the sanitary drain when condensate supply was greater than demand, 129,776 gallons or 22% of the 597,857 gallons produced would be wasted. One could choose this option if the cost of the system proved reasonable for the economic and other benefits received.

Adding a storage tank provides a means to accumulate the water collected during abundant periods for use later when needed. If cost or space were not a factor, a storage tank would be sized such that all collected water is used. However, cost and space are real factors that prompt careful consideration of design decisions.

For example, to capture and use nearly all of the condensate listed in Table 7.4, a 130,000-gallon tank (or multiple smaller interconnected tanks) costing tens of thousands of dollars and occupying facility space would be necessary. Even then, makeup water is still required for 4 months (Jan–Apr). This prompts the question “Is it worth the investment?” The additional costs of installing a tank would include pipes, pumps, a pressure tank, and treatment. One could choose this option with a tank large enough to store all the excess condensate produced or could instead choose a smaller tank based on an economic analysis (see Chapter 12) to store only a portion of the water.

To increase the return on investment (i.e., shorten the payback period) from a reclaim water system, another application can be explored, another reclaim source can be added, or both. For example, if reverse osmosis is used in the office building to purify drinking water, a steady flow of wastewater (i.e., potable water with higher concentrations of minerals) from this purification process can also be routed to the water storage tank. The steady supply of reverse osmosis wastewa-

ter added to the condensate would help supply reclaim water needed during the cooling months. However, there would now be a surplus during the heating months, which must either be used on an additional application, such as irrigation, or discharged down the sanitary drain.

This supply and demand dilemma is the reason that rainwater and condensate are commonly combined and used for irrigation. The condensate provides a steady source of water during the hot and humid months of summer, when water is most needed for irrigation and rainwater sporadically adds large quantities to fill the tanks. The rainwater available to harvest for use at the 110,000-square-foot office building site, assuming a two-story building, is shown in column 5 of Table 7.4 for reference. The total water supply from condensate and rainwater combined can be compared to irrigation demands to determine the appropriate size of water storage tank needed for the best return on investment for an irrigation application (see Chapters 12 and 13).

Calculations for rainwater harvesting are described in multiple resources, including the *Texas Manual on Rainwater Harvesting* and the *Rainwater Harvesting: System Planning* publications (Texas Water Development Board 2005, Mechell et al. 2010). For reference, Table 7.5 lists the average monthly temperature and rainfall compiled from the National Climate Data Center database for the San Antonio International Airport (National Climate Data Center 2012).

Table 7.5 Average monthly meteorological data for San Antonio (Source: National Climate Data Center)

	Jan	Feb	Mar	Apr	May	Jun	Jul	Aug	Sep	Oct	Nov	Dec
Temperature (°F)	52	56	62	69	77	82	85	85	80	71	61	53
Rainfall (inches)	1.8	1.8	2.3	2.1	4.0	4.1	2.7	2.1	3.0	4.1	2.3	1.9

Maximum Condensate Flow Rate Calculations

Knowing the maximum expected condensate flow rate is important in determining the largest pipe diameters, meters, pumps, and other components used to transport the condensate from the AHU to the water point-of-use, or the sanitary drain. One can estimate the maximum condensate flow rate using the expected highest dew point for the year.¹¹

The *ASHRAE Handbook—Fundamentals* (2009) lists the dew-point temperature and mean coincident dry-bulb temperature corresponding to the most extreme dehumidification design conditions in San Antonio, Texas, with a 1% probability of occurring, as 75.2°F and 79.8°F, respectively. This corresponds to values of $T_o = 79.8^\circ\text{F}$ and $\text{RHo} = 85.9\%$, which can be applied to Equation 7.2 or Equation 7.5 to calculate upper limits for potential condensate production.

Assuming a supply condition of $T_s = 55^\circ\text{F}$ and $\text{RH}_s = 94\%$ with operation at 100% capacity with 100% outside air at the extreme dehumidification design condition stated above, the resulting condensate rate per 1,000 cfm airflow through the AHU is 0.089 gpm. Likewise, assuming the same extreme conditions with a base airflow (Q_{base}) of 350 cfm per ton total cooling capacity, the resulting condensate rate per ton cooling capacity of the system is 0.031 gpm. This maximum potential will occur only if and when extreme conditions coincide and is not expected to be a sustained condensate flow rate. The amount of condensate is dependent on the amount of outside air mixed with return air entering the AHU.

Example 7.12 Assuming the supply air condition (T_s , RH_s) for a commercial building with 420 tons total cooling capacity is around 55°F and 94% relative humidity, the maximum condensate flow rate one can expect with a probability of occurring only 1% of the time is 0.031 gpm per ton times 420 tons, or 13 gpm.

¹¹“Peak dehumidification load occurs when the outdoor dew point is at its highest point for the year—not when the outdoor dry bulb temperature is at its peak” (Harriman and Lstiburek 2009)

Since San Antonio, Texas, is predominantly hot and humid, most of the heat extracted from the air passing through the AHU is used to cool the moisture in the air. In fact, San Antonio is among the cities with the highest cumulative dehumidification and cooling loads for ventilation air per year (Harriman, Plager, and Kosar 1997). This signifies that San Antonio is a prime location to benefit from abundant reclaimed condensate used on-site.

With respect to the pipe diameter, the minimum pipe diameter of $\frac{3}{4}$ inch permitted for condensate from an AHU (up to 20 tons of cooling capacity) handles up to an estimated 1.6 gpm. If multiple AHUs are combined to form the total-ton cooling capacity of the building, each AHU must have a pipe attached to the drain pan outlet which, when combined, must satisfy the manifold pipe diameters shown on Table 9.1 [IMC§307.2.2]. For Example 7.12, Table 9.1 dictates that the 420 tons total cooling capacity have at least a 2.0 inch diameter drain pipe, which would transport up to 19.1 gpm of gravity-driven flow. The 19.1 gpm flow capacity of the pipe is well above the 13 gpm maximum condensate flow expected.

Improvements in Condensate Rate Predictions

The author of this manual, in coordination with SAWS, is collecting data from meters measuring the amount of condensate produced by commercial building AHUs in order to validate and refine condensate prediction models. If you would like to participate in this study or would like more information on how to meter your condensate, please e-mail <conserve@saws.org> for more information. Each participant in the study will be provided with a personal building profile based on the information they submit for analysis.

References

- Alliance for Water Efficiency. "Condensate Water Introduction." <www.allianceforwaterefficiency.org/Condensate_Water_Introduction.aspx> Accessed 27 August 2012.
- American Society of Heating, Refrigerating, and Air-Conditioning Engineers. 2005. *ASHRAE Pocket Guide for Air Conditioning, Heating, Ventilating, Refrigeration*. Atlanta, GA.
- American Society of Heating, Refrigerating, and Air-Conditioning Engineers. 2009. *2009 ASHRAE Handbook—Fundamentals*. Atlanta, GA.
- Bryant, J. A., and T. Ahmed. 2008. "Condensate Water Collection for an Institutional Building in Doha, Qatar: an Opportunity for Water Sustainability." Proceedings of the Sixteenth Symposium on Improving Building Systems in Hot and Humid Climates. Dallas, TX, 15-17 December.
- Environmental Protection Agency. 2008. "National Efficiency Standards and Specifications for Residential and Commercial Water-Using Fixtures and Applications." <www.epa.gov/watersense/docs/matrix508.pdf> Accessed 28 August 2012.
- Guz, Karen. 2005. "Condensate Water Recovery." *ASHRAE Journal*, 47(6): 54-56.
- Harriman, L., G. Brundrett, and R. Kittler, 2001. *Humidity Control Design Guide for Commercial and Institutional*. Atlanta, GA: ASHRAE.
- Harriman, Lewis G., and Joseph W. Lstiburek. 2009. *The ASHRAE Guide for Building in Hot and Humid Climates*. 2nd ed. Atlanta, GA: ASHRAE.
- International Code Council. 2011. *2012 International Mechanical Code [IMC]*.
- Lawrence, Tom, Jason Perry, and Tyler Alsen. 2012. "AHU Condensate Collection Economics." *ASHRAE Journal*, 54(5): 18-25.

- Lawrence, Tom, Jason Perry, and Peter Dempsy. 2010. "Capturing Condensate by Retrofitting AHUs." *ASHRAE Journal*, 52(1): 48-54.
- Mechell, Justin, Billy Kniffen, Bruce Lesikar, Douglas Kingman, Fouad Jaber, Rachel Alexander, and Brent Clayton. 2010. *Rainwater Harvesting: System Planning*. B-6240. College Station: Texas Agrilife Extension Services.
- Munters Incorporated. "Munters Psycalc Software." <www.munters.us/psychtools> Accessed 18 March 2012.
- National Climate Data Center. NCDC Climate Information Online. <www7.ncdc.noaa.gov/CDO/dataproduct> Accessed 19 June 2012.
- National Renewable Energy Laboratory. 2007. Typical Meteorological Year (TMY3) Database. <http://rredc.nrel.gov/solar/old_data/nsrdb/1991-2005/tmy3/> Accessed 27 August 2012.
- Painter, Frank L. 2009. "Condensate Harvesting from Large Dedicated Outside Air-Handling Units with Heat Recovery." *ASHRAE Transactions*, 115(Part 2): 573-580.
- San Antonio Water System. 2012. Personal communication with the Conservation Department.
- Sieber, Roy. 2010. "Alternate Sources of Water for Cooling Tower Make-Up." GovEnergy Conference. Dallas, TX, 15-18 August.
- Texas Water Development Board. 2005. *Texas Manual on Rainwater Harvesting*. 3rd ed. <www.twdb.state.tx.us> Accessed 27 August 2012.
- Trent, Warren C., C. Curtis Trent, and Hudy C. Hewitt. 1998. "Condensate Control." Sections 2.31-2.3.30 in *HVAC Systems and Components Handbook*, edited by Nils R. Grimm and Robert C. Rosaler. New York: McGraw-Hill.
- US Green Building Council. 2009. *LEED Reference Guide for Green Building Design and Construction*. Washington, DC.
- Wilcut, Eddie, and Elliot Fry. 2010. "Air Conditioning Condensate Calculator." <www.buildinggreen.com> Accessed 27 July 2012.

8

Design and Implementation Process

As with most building systems, implementing a condensation collection and use system during new construction is typically easier and less expensive than retrofitting existing buildings to accommodate the feature later. Early implementation allows the system to be developed as an integral part of the building, which adds measurable value to the project. Later implementation of a condensation collection system as an unplanned add-on will often hinder full optimization of the system. The dots in Table 8.1 suggest the ideal involvement, decisions, and responsibilities of the relevant players related to a condensate collection and use system during the typical phases of a conventional building construction project.

Table 8.1 Design and implementation coordination matrix for condensate system in new construction

Phase	Participant Coordination								
	Architect	Engineer	Landscape Designer	Building Contractor	Building Owner	Facility Manager	SAWS ^a	City	Commissioning Agent
Schematic design	●	●			●	●	●		
Design development	●	●	●		●		●	●	
Construction documents	●	●	●	●	●		●	●	●
Construction	●	●	●	●	●	●	●	●	●
Commissioning					●	●	●	●	●
Start-up O&M				●	●	●	●		

^a SAWS = San Antonio Water System

For existing buildings, if no building modifications are required, the architect may be excluded from the matrix of responsibilities, and then the phases represent the design and construction of the condensate system alone. In such cases, the engineer or building contractor takes on the responsibilities of the architect. Likewise, if circumstances preclude involvement of any of the participants listed in Table 8.1, another participant must fulfill their role.

Schematic (Conceptual) Design Phase

The architect, in collaboration with the engineer, determines how best to capture and use available reclaimed water sources in a practical and economic manner for the proposed building, per the owner's Basis of Design. The owner's Basis of Design is a document describing the owner's fundamental goals and ideas for the building. The architect determines how much reclaimed water to collect, from which sources (e.g., rainwater, condensate, reverse osmosis, groundwater), and where to locate the associated equipment. Considerations around how much reclaimed water to collect include (i) possible uses for the reclaimed water; (ii) whether a collection tank is necessary and whether that tank can be located above ground or underground; (iii) treatment requirements; (iv) metering requirements; and (v) whether a passive or an active system is feasible. Active systems use pipes, tanks, and pumps, while passive systems use no moving parts and store the water in a natural environment (e.g., a pond) rather than in a tank. The architect presents conceptual schemes to stakeholders for review and approval. The stakeholders are the building owner, engineer, facility manager, and San Antonio Water System (SAWS). Schemes include elevations, proposed tank materials, site-specific elements, and a water flow diagram showing how the proposed design works.

Design Development Phase

The design team (architect, engineer, landscape designer, SAWS, city, and building owner) works on condensate calculations based on proposed heating, ventilation, and air-conditioning (HVAC) system design and historical weather data (see Chapter 7). Likewise, water available from other sources, such as rainwater, is calculated using appropriate estimation techniques. The estimated water available from reclaimed sources is then compared to predicted water consumption for the site (e.g., irrigation, cooling tower makeup, toilet flushing) to determine optimal combination of reclaimed water use sources. The water supply versus demand values are used to determine total water collection and system size. Since landscape irrigation is one of the largest consumers of water, changes in landscape design should be considered at this time to reduce water usage before sizing the system. The Environmental Protection Agency (EPA) publication *WaterSense at Work: Best Management Practices for Commercial and Institutional Facilities* provides a good overview of water conservation strategies for outdoor water use (Environmental Protection Agency 2012). The engineer responsible for location and design of utilities for the site, if different from the engineer working on the design team, should be consulted during this phase.

The architect refines the building design to incorporate the optimal collection system. The architect evaluates the impact of proposed rebates on the initial cost and on the cost over the life cycle of the system. The architect, engineer, and landscape designer evaluate all applicable codes for compliance in coordination with the commissioning agent, SAWS, and the city. The evaluation of what uses the system will serve and the required measures of treatment are critical at this juncture. If water will be used strictly for landscape irrigation, the architect and landscape designer inquire whether SAWS can waive the required irrigation meter, as well as any associated impact fees. These fees are associated with first cost savings and considered with rebates in calculating return on investment in terms of payback period (see Chapter 12).

The architect presents the long-term sustainability, associated reduction in water carbon footprint (see Chapter 13), water management implications, and other associated benefits to stakeholders (building owner, SAWS, city, commissioning agent). Ideally, the building owner makes the final decisions about the system design at the conclusion of this design development phase. However, in many cases the building owner only makes tentative decisions in this phase while he or she waits for final pricing to be made available for the final decision at the end of the construction documents phase.

Construction Documents Phase

The engineer and landscape designer work with the architect on adding detail to the system design and incorporating commissioning requirements into the project specifications to ensure that the design intent expressed in the owner's Basis of Design is met. At this point in the process a commissioning agent may be engaged (if one is not already involved) to act on the building owner's behalf to ensure and demonstrate that the building performs as designed. Ideally, a third-party commissioning agent is hired. Otherwise, the engineer's, landscape designer's, or facility manager's firm can be designated by the building owner to perform these functions, depending on who designed most of the system and understands how it works.

The engineer and landscape designer, in coordination with the architect, refine calculations based on final HVAC selection and system design. All component of the system are detailed, including filtration and water treatment system (if applicable), appropriate pipe size for condensate flow, sequence of operations, pump sizes, pressure tanks (if applicable), solenoid valves, and water meters for data collection (if applicable).

To ensure quality control of system design, the design team and SAWS review drawings at 50% and 90% completion prior to the final set of drawings being issued for permit and construction. The 100% complete set of drawings is issued to the city for review, after which the city issues a permit for the project design. The design team announces the project for construction bids, unless the project was already bid as a comprehensive design-and-build project, in which case the construction team has already been selected. The final projected costs are included in the submitted bids, allowing the building owner to make final decisions related to the condensate system, if they have not already.

It is recommended that costs associated with the reclamation system be listed separately in any bid, as these are tax exempt in Texas. It can be useful to keep track of all associated costs in order to calculate the first cost of the system (i.e., up through completion of the commissioning phase) and to estimate the payback period for the investment (see Chapter 12).

Construction Phase

The contractor and subcontractors attend pre-construction meetings to ensure that design intent is understood and that commissioning will take place at predictable intervals in the contractor's schedule throughout the construction project. The commissioning agent or engineer hands out pre-functional and functional checklists to be followed. This ensures that systems work as intended and allows the installer of the systems to develop a sequence of operation and to raise practical questions about the system. Before the water reclamation system is installed, a meeting of all disciplines involved is recommended to assign responsibilities and agree upon a schedule. This ensures that all tradespeople know who is doing what and to what point of completion. This minimizes miscommunication during construction.

Commissioning Phase

The commissioning agent verifies that all items are working per the commissioning plan and ensures that items which need to be addressed by the design team or trades are promptly resolved. The engineer typically attends key testing during commissioning. As part of the commissioning process and final closeout of the building, the contractor and commissioning agent train the building owner's representative on the maintenance of the reclaimed water system. The commissioning agent is responsible for preparing comprehensive operations and maintenance (O&M) manual. The manual should be provided to the building owner prior to the issuance of the Certificate of Occupancy in the case of new construction [IGCC§904.1]. The manual should include a detailed system schematic showing locations of all system components and provide a list of all system

components, including manufacturer and model number [IGCC§707.13.2]. The maintenance portion should include a maintenance schedule and procedures for all system components requiring periodic maintenance, complete with the part numbers for consumable components, such as filters and lamps [IGCC§707.13.3]. The operations portion should include system startup and operating and shutdown procedures [IGCC§707.13.4]. Details on maintaining the required water quality as determined by the authority with jurisdiction (e.g., Texas Commission on Environmental Quality) should also be part of the manual [GPMCS§501.6]. Maintenance and warranty documents are handed to the building owner at this time. Final inspection by SAWS and the city will verify whether the system is working per code. Once SAWS approves the system, all final rebates will be issued to the building owner. The IGCC requires a post-occupancy commissioning report be provided to the building owner within 30 months after the Certificate of Occupancy, in the case of new construction, is issued for the project [IGCC§903.1.2].

Start-Up Operation and Maintenance Phase

It is recommended, when feasible, that the building owner purchase a maintenance contract for the first year, as this serves to encourage the development of good maintenance habits. The building owner is responsible for keeping a maintenance log and ensuring that the system is working properly prior to the warranty expiration date. The log includes the frequency of inspections, tests, and maintenance for each part of the system [GPMCS§501.5.2]. If the system needs to be adjusted, it is recommended that these adjustments be made during the warranty period. SAWS requires that meter data be reported to SAWS as a condition of receiving a SAWS rebate. In addition to reporting metered data to SAWS, the building owner can compare this data to analytical design data at the end of the first year of operation to verify accurate performance estimates. The building owner or designated agent must have the backflow preventer assembly tested by a State of Texas licensed backflow assembly tester at the time of installation, repair, or relocation and at least annually thereafter, or more often when required by the code official [SAPC§608.13.12].

A detailed condensate collection system design and implementation checklist up through the start-up phase is included as Appendix E. A separate comprehensive minimum frequency inspection, test, and maintenance checklist from start-up through the life of the system is provided as Appendix F and addressed in Chapter 11.

Testing of water quality is a critical part of the O&M of a reclaimed water system. Water quality requirements depend on which, if any, additional reclaimed water sources are commingled with condensate in the storage tank (e.g., rainwater) as well as the intended application of the reclaimed water. The IGCC recommends that test records be maintained for at least two years [IGCC§707.15.1.2]. Information on water quality tests can be found in EPA, American Public Health Association (APHA), National Sanitation Foundation (NSF), American National Standards Institute (ANSI), and Texas Administrative Code (TAC) documents. See Chapters 4–6 for a discussion of water quality and treatment methods.

References

- City of San Antonio. 2011. *San Antonio City Code*, Chapter 10, Article IX: Plumbing Code [SAPC], per Ordinance 2011-12-01-0984.
- Environmental Protection Agency. 2012. *Water Sense at Work: Best Management Practices for Commercial and Institutional Facilities*. EPA 832-F-12-034. Washington, DC.
- International Association of Plumbing and Mechanical Officials. 2012. *2012 Green Plumbing and Mechanical Code Supplement [GPMCS]*.
- International Code Council. 2012. *2012 International Green Construction Code [IGCC]*.

9

Condensate System Components

Reclaimed condensate system components extend from the condensate drainage port on the air-handling unit (AHU) to the point-of-use of the reclaimed water. If the water is used for irrigation, the point-of-use is considered the delivery line, after treatment, to the irrigation system. When municipal makeup water or other reclaimed water, such as rainwater, is added to the condensate, proper integration of these other systems must be addressed in terms of materials, water treatment, and connections. Reclaimed water systems must be installed in compliance with the laws, rules, and ordinances applicable in the jurisdiction, along with the manufacturer's instructions, as applicable.

Condensate Lines

Permissible materials for condensate drain lines and components

Components of the condensate collection or disposal system must be made of cast iron, galvanized steel, copper, cross-linked polyethylene, polybutylene, polyethylene, ABS, CPVC, or PVC pipe or tubing [IMC§307.2.2]. Due to the slightly acidic nature of condensate,¹ materials prone to corrosion are avoided where possible, especially if chemical traces of pipe or tubing materials picked up by the water are unacceptable for the intended application. These material considerations extend to fittings and joints as well as components, such as pumps and valves.

In addition, piping, joints, fittings, plumbing components, and materials used in the collection system must meet pressure and temperature ratings for the installation [IMC§307.2.2] and must be manufactured of material approved for the intended application and compatible with any disinfection and treatment system used [IGCC§709.6]. In general, if PVC, CPVC, or PEX pipe is installed outside and above ground, it should be protected from ultraviolet (UV) light to avoid UV-light-induced deterioration of the pipe. Other pipe materials are commonly used for installations that are outside and above ground to avoid this issue.

Sizing of condensate drain lines (gravity-driven)

Condensate drain lines are sized assuming a gravity-driven flow. Drain lines must be greater than or equal to ¾-inch internal diameter and must not decrease in size from the drain pan connection to the place of condensate disposal or use [IMC§307.2.2]. The minimal allowable diameter is consistent with the fact that the discharge port where condensate exits the AHU is typically a ¾-inch national pipe thread taper (NPT) connection. Where drain lines from more than one air-conditioning unit are connected through a larger manifold pipe, the drain line must be sized in accordance with Table 9.1 [IMC§307.2.2].

The minimal permissible horizontal slope in the direction of discharge is a ¼-inch vertical drop per horizontal linear foot of travel in the direction of water discharge [IMC§307.2.1]. Care must be taken to ensure continuous horizontal slope along the discharge path by proper installation

¹ Condensate is generated in the same manner as distilled water, which is known to have a slightly acidic pH value—around 5.8, as compared to a neutral pH value of 7.0 (Buzzle).

of pipe joints and pipe hangers to avoid collection of water along the discharge path [IPC§704, IPC§705, IMC§305]. Stagnant water creates the potential for undesirable bacterial growth and should be avoided by proper design. Reclaimed and recycled water pipes must be properly labeled as such (see Chapter 10).

Table 9.1 Condensate drain sizing [IMC§307.2.2] and associated maximum permissible flow rate

Equipment Capacity	Minimum Condensate Pipe Diameter (inches)	Associated Full-Pipe Flow Based on Drain Pipe Size and 1/8-Inch Slope ^a (gpm)
Up to 20 tons of refrigeration	0.75	1.6
Over 20 tons to 40 tons of refrigeration	1.0	3.0
Over 40 tons to 90 tons of refrigeration	1.25	6.4
Over 90 tons to 125 tons of refrigeration	1.5	9.7
Over 125 tons to 250 tons of refrigeration	2.0	19.1

^a Calculated using Manning's formula for PVC pipe

Sizing of reclaimed/recycled water lines (pressure-driven)

Once the water passes through a pressure and/or flow rate regulating system, the reclaimed/recycled water service piping and fittings must be sized in accordance with the International Plumbing Code (IPC) for the sizing of potable water lines and fittings [SAPC§1304.3.5]. For example, the pressurized service lines running from a reclaimed water storage tank to an irrigation system must adhere to sizing used for potable water lines under the same operating conditions.

Insulation of drain lines

Condensate drain lines are insulated for one of two reasons: freeze prevention or drip prevention. Primary drain lines located in an unconditioned attic space must be insulated with foam plastic rubber-based insulation or other approved material with a minimum thickness of ¾ inch [SAMC§307.2.2]. Drain lines located in crawl spaces do not have to be insulated [SAMC§307.2.2]. Drip prevention is prudent when the cool condensate drain lines are exposed to humid ambient conditions in locations where condensate dripping from the external surface of the pipe would cause a safety or human health risk, such as near electrical equipment and walkways.

Separation of Water Lines

The code requirements for separation of reclaimed/recycled lines from potable water and sewer lines in trenches are intended to reduce the risk of contamination of the potable water supply by the recycled/reclaimed water and the contamination of the recycled/reclaimed water by sewage.

Separation requirements for reclaimed/recycled and potable water lines

Per the San Antonio Plumbing Code (SAPC), reclaimed/recycled water pipes must not be placed in the same trench as potable water pipes. A 2-foot horizontal separation must be maintained between pressurized, buried reclaimed/recycled water and potable water piping. Buried potable water pipes crossing pressurized reclaimed/recycled water pipes must be placed a minimum of 12 inches above the reclaimed/recycled water pipes and must have a PVC sleeve that extends a minimum of 2 feet on either side of the pipe crossing. Reclaimed/recycled water pipes must be protected in the same manner as potable water pipes (see Figure 9.1) [SAPC§1304.3.3]. In the event that a cross connection between reclaimed/recycled and potable water is detected, follow the procedures outlined in Appendix G.

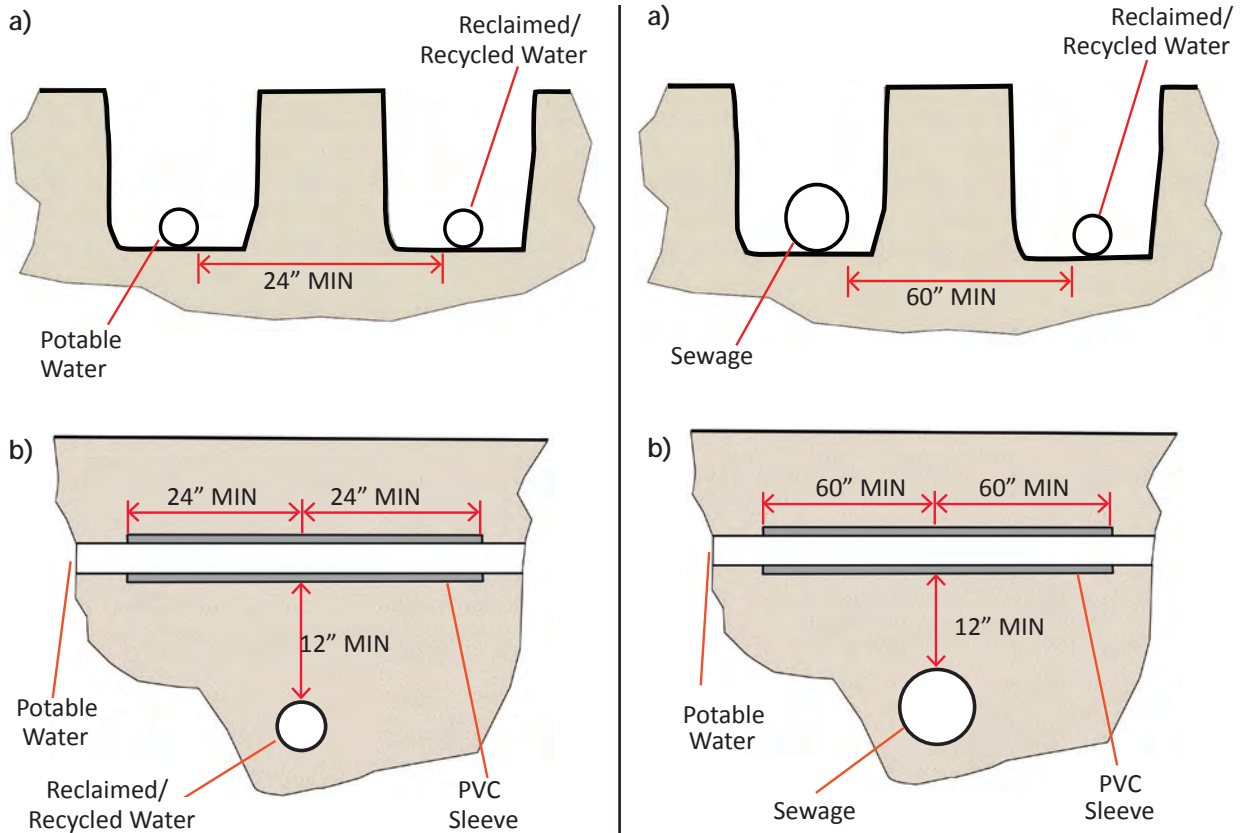

Figure 9.1 Separation of pressurized recycled/reclaimed water and potable water piping oriented (a) parallel in separate trenches and (b) perpendicular to one another.

Separation requirements for reclaimed/recycled service and building sewer

Reclaimed/recycled service pipe is treated the same as potable service pipe with respect to sewer lines [SAPC§1304.3.3]. As such, the reclaimed/recycled service pipe and the building sewer must be separated by 5 feet of undisturbed or compacted earth with the following three exceptions: (i) where reclaimed/recycled pipe is a minimum of 12 inches above the highest point of sewer line and pipe materials conform to standards in Table 702.3 of the IPC, (ii) where water service pipe is permitted to be located in the same trench with building sewer, provided sewer is constructed of materials listed in Table 702.2 of the IPC, and (iii) where the water service pipe is sleeved to at least 5 feet horizontally from the sewer pipe centerline on both sides of crossing with pipe materials listed in Tables 605.3, 702.2, or 702.3 of the IPC (see Figure 9.2) [IPC§603.2].

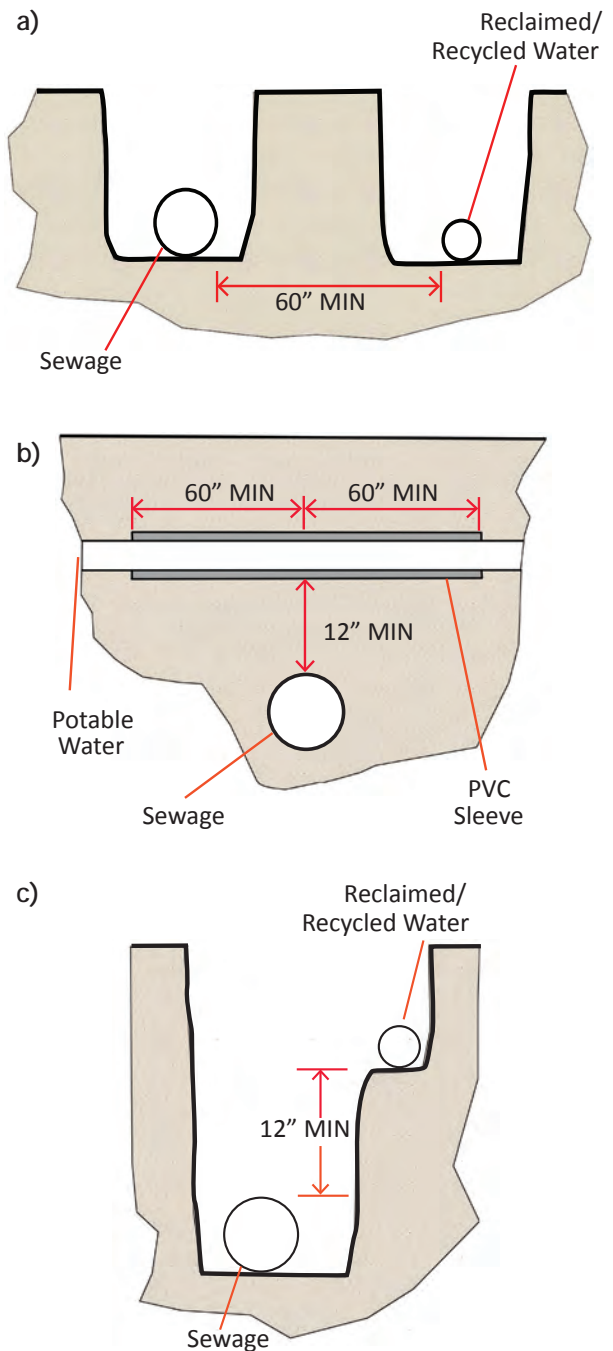

Figure 9.2 Separation of pressurized recycled/reclaimed water service piping and building sewer orientation (a) parallel (b) parallel with water service on shelf and (c) perpendicular.

In addition, water service pipes (including reclaimed/recycled pipes) must not be located in, under, or above cesspools, septic tanks, septic tank drainage fields, or seepage pits [IPC§603.2.1]. Buried reclaimed/recycled collection and distribution piping must comply with the requirements of section 306 of the IPC for support, trenching, bedding, backfilling, and tunneling [IGCC§709.8].

Condensate Drain System Seals

The purpose of the condensate drain system seal is to isolate the AHU from outside pressure conditions and allow the condensate to drain freely. The type of seal required depends upon whether the AHU is a draw-through or a blow-through system. In draw-through systems, the fan is located downstream of the cooling coil and the drain pan operates at a negative pressure (see Chapter 1). In blow-through systems, the fan is located upstream of the cooling coil and the drain pan operates at a positive pressure. Drain seals are required to prevent draw-through systems from ingesting ambient air and to prevent blow-through systems from exhausting conditioned air.

In draw-through systems, the air ingested through an unsealed drain outlet may be contaminated and pose a health threat. In addition, the pressure differential across the condensate drain pan outlet causes condensate to stand in the drain pan, often preventing condensate drainage and sometimes resulting in condensate overflowing the drain pan. Further, air entering the drain inlet at high velocity entrains condensate and sprays it onto internal components. These conditions not only cause damage to equipment, the buildings and the building contents, but also present a potential health hazard. Standing condensate in the drain pan, along with the wet internal components, provides a fertile growth place for health-threatening microorganisms (Trent et al. 1998).

In blow-through systems, drain seals are essential but are less critical than for draw-through systems. The positive pressure in the drain pan forces air to flow out through an unsealed drain pan outlet. Unlike the draw-through system, the blow-through systems reduces condensate standing in the drain pan as condensate entrained in the air exiting the AHU through the drain pan outlet also exits the AHU. However, there is an efficiency penalty associated with the conditioned cool air being unintentionally exhausted to the outside of the building when the drain seal fails in blow-through systems.

Condensate drain systems must be sealed as required by the equipment or appliance manufacturer [IMC§ 307.2.4] and are not required to be vented like sanitary drainage traps [IPC§Ch8]. The four common condensate drain system seal designs installed in buildings with draw-through AHU are the p-trap, the p-trap with added features, the in-pan condensate pump, and the pneumatic flow control system. These drain seal designs are illustrated in Figure 9.3. The vast majority of commercial AHUs are the draw-through type.

In cases where damage to building components could occur as a result of a drain system seal failure and subsequent drain pan overflow, an auxiliary (backup) drain system or AHU shutoff must be used [IMC§307.2.3].

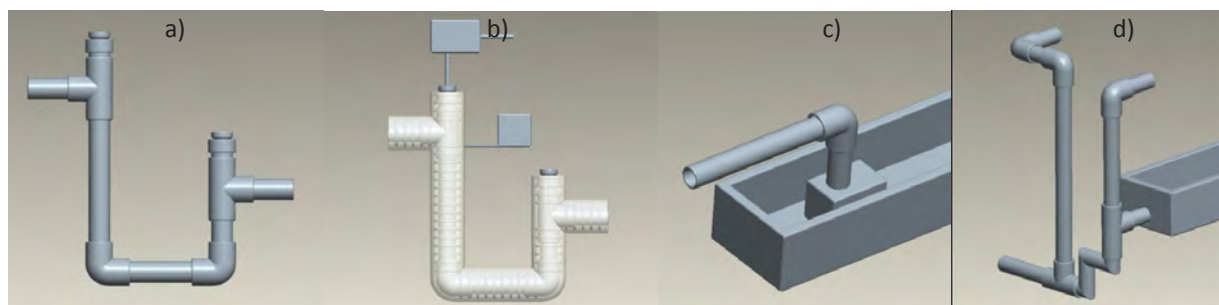

Figure 9.3 Schematics of common condensate drain system seals for HVAC systems: (a) p-trap, (b) p-trap with additions, (c) condensate pump, and (d) pneumatic seal

P-trap

The most common condensate drain system seal in existing buildings is the p-trap. The p-trap relies on the continuous presence of water in the trap to act as the seal against air passage in either

direction through the drain line, thereby isolating the AHU from the outside environment. See the article by Brusha (2001) for p-trap design specifications. Unfortunately, the p-trap design is ill suited as a condensate drain system seal and suffers frequent failures, as outlined in the excerpt below from ASHRAE Standard 62-89R (American Society of Heating, Refrigerating, and Air-Conditioning Engineers 1989):

Condensate traps exhibit many failure modes that can impact on indoor air quality. Trap failures are due to freeze-up, drying out, breakage, blockage, and/or improper installation and can compromise the seal against air ingestion through the condensate drain line. Traps with insufficient height between the inlet and outlet on draw-through systems can cause the drain to back-up when the fan is on, possibly causing the drain pan to overflow or water droplet carryover into the duct system. The resulting moist surfaces can become sources of biological contamination. Seasonal variations, such as very dry or cold weather, may adversely affect trap operation and condensate removal.

These failures often go unnoticed and or untreated until costly equipment damage or poor air quality is detected. Two examples of building-related illnesses from air contamination in draw-through AHUs are (i) Legionnaires' disease from bacterial contamination and (ii) inhalation of toxic gases from outside air that bypass a faulty drain seal. Because of common failures, an auxiliary drain system or AHU shut-off is required as a backup for the p-trap drain seal. Unless reliable scheduled inspections and subsequent maintenance is guaranteed, a p-trap is not a prudent choice for a condensate system drain seal.

P-trap with additions

Adding a heater and self-priming/flushing feature to mitigate p-trap freezing, drying out, and clogging improves the p-trap. However, these additional features add cost and themselves can incur electrical, mechanical, and control failures. An auxiliary drain system or AHU shutoff is required as a backup for the "p-trap with additions" drain seal. Note that if potable water is used for priming, the connection to the inlet side of the trap must include an approved vacuum breaker installed not less than 6 inches, or the distance according to the device's listing, above the flood-level rim of such trapped fixture, so that at no time will any such device be subjected to any back-pressure [IPC§608.15.4].

Condensate pump

One alternative to a p-trap is the installation of a pump in the drain pan to remove water from the drain pan when the water reaches a predetermined level. This design is often chosen when the drain or intended water application is above the elevation of the condensate drain pan located in the AHU. In this case the pump serves a dual purpose: to empty the drain pan and move the water to a higher elevation. The pump size depends on the desired pumping rate and required increase in water elevation for use or disposal. Failure of this drain seal option is due to mechanical or electrical failure of the pump or liquid level switch and/or flow blockage. These failures result in overflow of the drain pan, which leads to potential equipment and health hazards. Therefore, an auxiliary protection system in the form of a backup drain system or AHU shutoff is required for this option. Although this option requires power and can incur mechanical, electrical, and control problems associated with a pump, it is overall a more effective condensate drain system seal than the p-trap designs.

Pneumatic seal

An alternative to a p-trap and a condensate pump is a pneumatic seal. The pneumatic seal has no moving parts and operates on airflow created by pressure differentials in the heating, ventilation, and air-conditioning (HVAC) system. The pneumatic seal requires no maintenance and by design avoids the failures associated with the other options. The self-regulating and foolproof nature

of the pneumatic seal makes it an obvious choice over the p-trap and the condensate pump for ease of operation. It does, however, come with a small energy penalty associated with intentional airflow out of the AHU through the drain line to maintain a positive flow of condensate from the AHU. For example, “Approximately 7-cubic feet per minute of air is pushed through the drain line leg of a commercially available pneumatic seal. This is on the order of 0.06% of the conditioned (cooled) air passing through a 30-ton HVAC unit” (Trent 2011). The energy penalty shrinks as the tonnage of the AHU increases because the 7 cubic feet per minute is a smaller percentage of the total flow as the total flow increases. The commercially available pneumatic seal² can handle up to negative 5 inches of water drain pan pressure in a draw-through unitary or split AHU up to 100 tons with a ¾- to 2-inch diameter drain pipe size and up to positive 5 inches of water drain pan pressure in a blow-through AHU. Several major HVAC manufacturers now offer the pneumatic seal as an option when ordering an AHU unit. An auxiliary drain system or AHU shutoff mechanism is required in case the drain pan exit or lines downstream of the pneumatic seal become clogged.

Comparison of condensate drain seal options

A properly functioning drain seal is critical to maintaining good indoor air quality and preventing costly equipment damage. Unless reliable scheduled inspections and maintenance is guaranteed, the water-filled p-traps are not a practical solution to continuously seal the condensate drain. Of the two remaining options, the pneumatic flow control is preferable because it is self-regulating and self-cleaning. It requires the least attention and maintenance over the lifetime of the system.

However, if the condensate must be pumped to a higher elevation to reach the location of the intended application or to reach a drain, then a pump will be required anyway, and leveraging the pump in the condensate pump drain seal design can optimize the systems for these two requirements. A third factor that can be leveraged in consideration with the pump is metering the condensate rate. Several of the metering options require a pump to force water through a meter. Often a reservoir and pump are included downstream of the drain seal to separate the function of the drain seal from the system used to elevate the condensate. Since the choice of one component may influence the choice of another component, it is wise to consider the system design holistically, especially when evaluating choices related to pumps and flow path.

The characteristics of each type of common condensate drain seal are summarized in Table 9.2. Data is not available for the frequency of failure for each type of drain seal. However, even limited failures can cause human health risks by allowing improper HVAC operation and subsequent growth of biological contaminants that get carried into building spaces by the conditioned airstream. Therefore, proper design and maintenance of the drain seal is imperative for good indoor air quality and should be a priority when implementing a condensate collection system.

Note that estimated first costs in Table 9.2 do not include materials and labor to install an auxiliary drain for any option, to supply electricity to the pumps for options 2 and 3, or to supply water to the automated primer/flusher in option 2. Maintenance costs and effort are expected for all options except the pneumatic flow control (option 4). More than 49,000 pneumatic flow control units (i.e., CostGard™) have been installed, and no failures have been reported to the company selling the units; inspection is only required to ensure proper installation and operation (Trent 2011).

² CostGard™ Condensate Drain Seal uses air to form the drain seal, instead of water. Trent Technologies, Inc., Tyler, TX 75703

Table 9.2 Summary of common condensate drain seals options

Drain Seal Options	Potential Failure Modes								Maintenance				Selection Factors						
	Poor Design	Poor Installation	Dry Trap	Blockage	Freezing	Cleanout Open	Mechanical	Electrical	Controls	Manual Prime & Flush	Electrical	Mechanical	Replacement of Parts	O&M Burden	Failure Risk	Requires Water Source	Requires Power Source	Requires Auxiliary Drain	First Cost ^a
P-trap	●	●	●	●	●	●				●				high	high			●	\$20
P-trap with additions	●	●				●	●	●	●	●	●	●		med	high	●	●	●	\$200-1,000
Condensate pump	●	●		●			●	●	●	●	●	●		low	med low		●	●	\$50-100
Pneumatic flow control		●												virtually nil	virtually nil			●	\$100-\$300

^a Estimated cost at time of publication of manual based on ¾-inch drain line

Auxiliary (backup) condensate drain system

Safeguards are designed into the condensate drain system to prevent water from backing up and subsequently overflowing the drip pan if the primary drain line becomes clogged or the drain seal fails. Where damage to any building components could occur as a result of overflow, one of the four methods in Table 9.3 is required [IMC§307.2.3]. An auxiliary condensate drain system and/or a warning alarm are recommended on all AHUs.

Table 9.3 Drain pan overflow protection methods [IMC§307.2.3]

Overflow Protection Methods	
1	Auxiliary drain pan with a separate overflow drain line to conspicuous point of disposal to alert facilities personnel
2	Primary drain pan with a separate overflow drain line (connected higher than the primary drain line) to conspicuous point of disposal to alert facilities personnel
3	Water-level detector, connected to HVAC shutoff, installed in auxiliary drain pan without a separate overflow drain
4	Water-level detector, connected to HVAC shutoff, installed in (i) primary drain pan above drain line connection and below rim of drain pan, (ii) primary drain line, or (iii) separate overflow drain line.

When an auxiliary drain pan is used, all parts and insulation subject to water damage must be above the rim level of the pan [IMC§307.2.3.2]. When an auxiliary drain pan and separate drain line are not feasible, option 4i in Table 9.3 must be employed. Option 2 is viable only if the secondary drain line is equipped with a reliable drain seal; otherwise an unsealed secondary drain seal causes the same types of problems as an unsealed primary drain seal. An alarm connected to an overflow indicator in the drain pan is a sensible addition to alert facility personnel if and when a drain seal failure occurs [IMC§307.2.3.1]. Detecting drain pan overflow prevents the numerous and potentially costly and hazardous effects of an overflowing drain pan on the inside of the AHU and on the conditioned space in the building.

Water Meters

Meters play an important role in monitoring condensate and alerting facility personnel of condensate system malfunctions. The meters used to measure the amount of condensate passing through the drain line are selected based on expected condensate rate, condensate properties, desired measurement accuracy, gravity-driven or pump-driven flow, ease of implementation, readout type, and cost. The *International Green Construction Code* (IGCC) requires all potable and non-potable water supplied to on-site applications be individually metered [IGCC§705.1]. In addition, the IGCC requires that the metering system be capable of communicating water consumption data remotely at least once a day and that there is sufficient data storage for the generation of daily, monthly, and annual reports [IGCC§705.1]. Similarly, *ASHRAE Standard 189.1* (2011) requires metering of alternative sources of water (>500 gallons per day) and automated data storage with ability to generate reports showing hourly, daily, monthly, and annual water consumption per meter. The City of San Antonio has not adopted the IGCC or *ASHRAE Standard 189.1*, so this level of metering is considered good practice, but not yet required in San Antonio. SAWS strongly encourages metering, but requires metering only for condensate systems that receive a SAWS rebate, in which case metered data must be reported to SAWS at least annually.

Types of flow meters/gauges

Automatic rain gauge

An automated rain gauge measures how many times a predetermined volume of water on each side of a tipping-bucket mechanism is captured and released (see Figure 9.4). Commercially available rain gauges with capture surface diameters up to 12 inches can measure up to about 0.05 gpm within a few percent accuracy. Larger custom gauges can be constructed. However, the time and effort to design, construct, and calibrate a custom gauge is usually impractical. Automatic rain gauges are designed to measure gravity-driven flows.

Positive displacement meter

Positive displacement meters are the most common meters used by water utility companies to measure residential water consumption (see Figure 9.5a). They are designed for installation in a horizontal pressurized water line with full-pipe flow down to 0.25 gpm for a positive displacement meter with a 5/8-inch national pipe thread taper (NPT) connection. A meter yoke (see Figure 9.5b) can be used to install positive displacement meters in vertically oriented water lines in order to keep the meter in a horizontal position and avoid measurement errors associated with a non-horizontal orientation.



Figure 9.4 Example of an automated rain gauge (Source: Spectrum Technologies Inc.)



Figure 9.5a Example of a positive displacement meter (Source: Mueller Systems LLC)

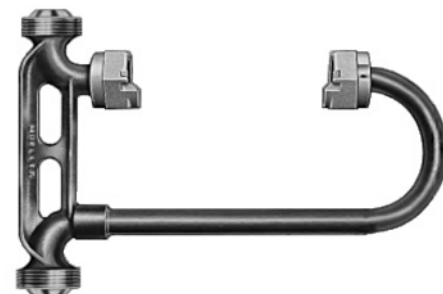

Figure 9.5b Example of a meter yoke (Source: Mueller Systems LLC)



Figure 9.6 Example of an electronic flow meter (Source: Elster AMCO Water Corporation)

Positive displacement meters can also be used in gravity-driven flow, however, the metering configuration must ensure full pipe flow and positive hydraulic pressure at the meter inlet to record meaningful measurements. In most cases, gravity-driven flow will not reach the pressure range at which the meter was rated. Similarly, at times the gravity-driven flow will be below the rated minimum flow of 0.25 gpm. Since manufacturers do not provide performance measurements for low-flow and low-pressure operation of positive displacement meters, further investigation is required to determine measurement accuracy below the rated range.³

Electronic flow meter

Electronic flow meters are also designed for installation in a pressurized water line with full-pipe flow (see Figure 9.6). The advantages of an electronic flow meter over the positive displacement meter are that it operates at lower pressures and lower flow rates (down to 0.05 gpm with a ¾-inch NPT connection), can be installed in any orientation, and has no moving parts. The disadvantage is that electronic flow meters are more expensive than positive displacement meters and experience a sharp decrease in performance below the rated operating range due to electrical noise in the measurement signal being about the same magnitude as the measurement signal itself. Like positive displacement meters, electronic flow meters can be used to measure gravity-driven flows if the metering configuration is such that positive hydraulic pressure is high enough at the meter inlet and the flow rate is adequate for accurate flow measurements, per manufacturer specifications.

Be aware that some electronic flow meters are based on technology that requires the water to be electrically conductive. The electrical conductivity of pure condensate is approximately 20 micro-Siemens/cm ($\mu\text{S}/\text{cm}$), whereas at least 50 $\mu\text{S}/\text{cm}$ is typically required for the fluid to be detected by electrically conductive types of meter (Elster AMCO Water Corporation 2012). Unless enough metal ions or other conductive contaminants have been picked up by the condensate along the flow path upstream of the flow meter, a conductive additive is required, which adds complexity to the system and might not be compatible with the intended use of the condensate water. Some electronic meters require straight-pipe flow several diameters upstream of the meters, which must be taken into account in the system design.

Meter configurations

Once the condensate flow rate is known, the operating criteria below can help evaluate which meter configuration, and associated meter, is optimal for a given situation. High-cost specialty meters are not considered practical for condensate applications and therefore are not included in this discussion.

In-line meters with gravity-driven flow

Placing meters in the drain line and relying on gravity-driven flow requires knowing the range of flow rates in advance. For very low flows consistently less than 0.05 gpm, a commercially available rain gauge can be implemented to measure the amount of condensate passing through the drain line, as shown in Figure 9.7a. However, this approach is viable only for small buildings with small AHUs on the order of 10 tons. Note that commercial buildings with a total tonnage of less than 10 tons are eligible for exception to the condensate collection ordinance for the City of San Antonio [SAWCR].

For flows consistently greater than about 0.05 gpm, electronic meters can be used. However, the sharp decrease in measurement accuracy below the operating range along with the need for electrically conductive fluid for some electric meters must be considered.

³ Positive displacement meters are being tested in the Engineering Science Department at Trinity University for performance at low-flow and low-pressure conditions, which simulates gravity-driven condensate flow through a drain line. Results will be published when the study is complete (Glawe 2013).

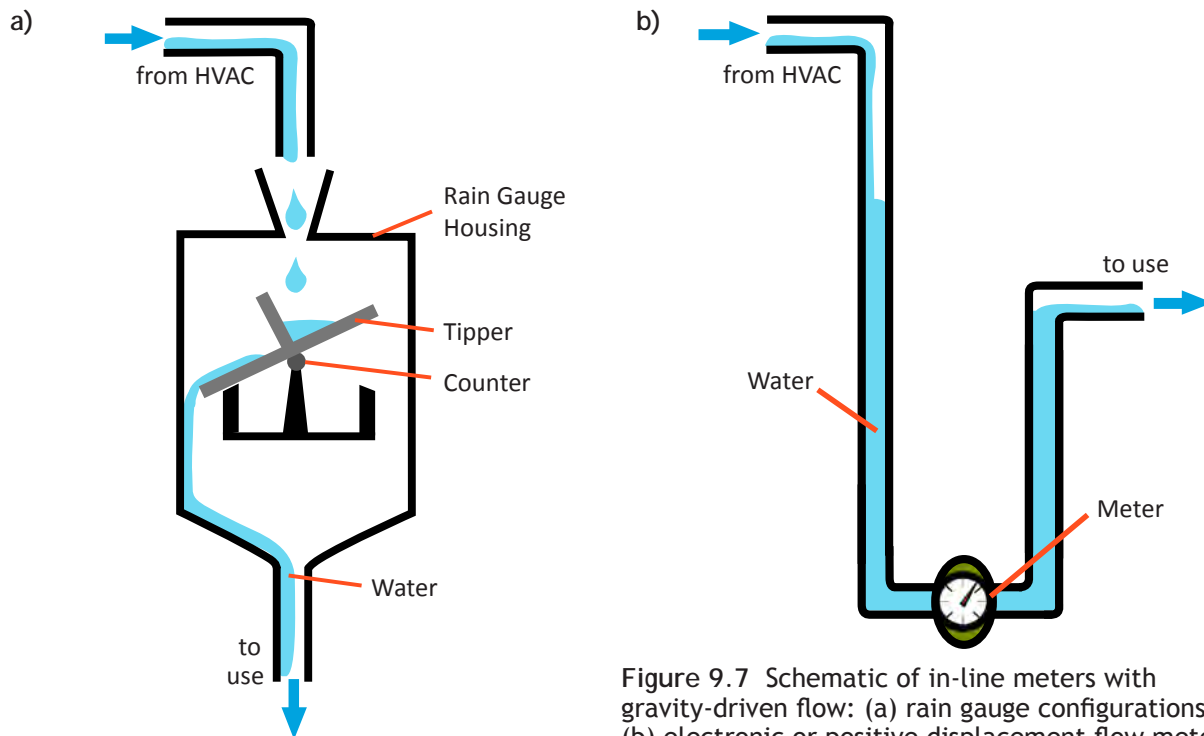

Figure 9.7 Schematic of in-line meters with gravity-driven flow: (a) rain gauge configurations; (b) electronic or positive displacement flow meter configuration. Overflow protection not shown.

For flows consistently greater than 0.25 gpm, positive displacement meters can be implemented with good accuracy, assuming that all criteria are met in Table 9.4. For flows lower than 0.25 gpm, positive displacement meters can still be implemented; however, the accuracy is not yet certain (Glawe 2013). In gravity-driven systems like these, care must be taken to properly design the flow path around the meter to ensure full-pipe flow and adequate pressure at the inlet and outlet of the meter, as illustrated in Figure 9.7b.

Since the positive displacement meter configuration functions as a trap, an air break must exist between this configuration and any other trap configuration in the drain line that can act as a drain seal. Otherwise, an air lock can occur between the two traps and prevent positive flow through the upstream trap. If the configuration illustrated in 9.7b is used, it must be carefully designed by a qualified professional to ensure positive flow.

If a pump is employed anywhere along the drain line to raise the water to a higher elevation, placing a meter immediately after the pump is more pragmatic than implementing a gravity-driven meter configuration.

In-line meter with pump driven flow from a reservoir

A properly sized in-line meter with pump-driven flow from a reservoir can be designed to meter virtually any flow rate of condensate through the reclaimed water system. The reservoir is used to store the water, while a pump and float switch are used to intermittently send a fixed volume of water through the flow meter, as depicted in Figure 9.8a. More specifically, when the water reaches a predetermined height in the reservoir, the flow switch activates the pump, which then pumps water from the reservoir at a rate acceptable for the selected meter. A one-way check valve installed between the pump and the meter prevents water from returning to the reservoir between pump cycles. If the drain pan is used as the reservoir in conjunction with the condensate-pump option for the drain seal, no additional pumps or float switches are required, only an appropriate water meter. However, the pump and meter must be carefully selected by a qualified professional to ensure positive flow given the operating parameters.

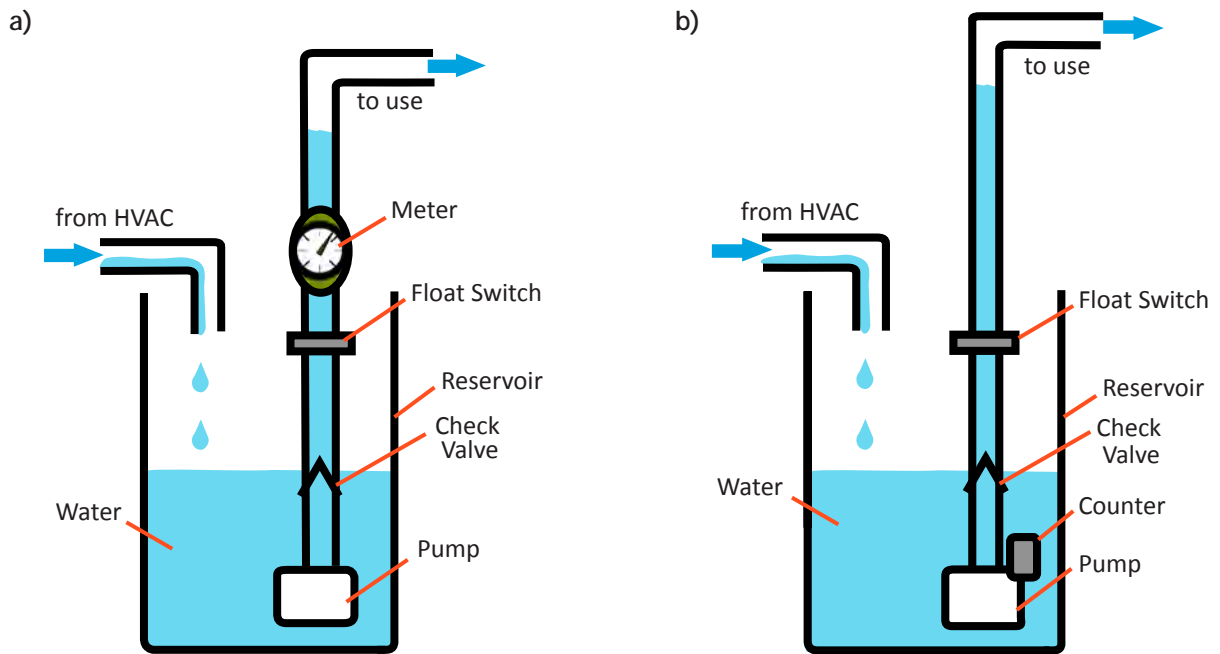

Figure 9.8 Schematics of pump-driven flow from a reservoir with (a) meter and (b) counter

Alternatively, a counter, as shown in Figure 9.8b, can replace the meter. Knowing the height of the water in the reservoir that triggers the pump, the associated volume of liquid in the reservoir can be calculated. Multiplying this fixed volume by the number of pumping cycles, as measured by the counter, results in the approximate volume of condensate that has passed through the drain lines per any given time period. The volume is approximate because as the pump is pumping water out of the reservoir, the reservoir is still filling. Therefore, some of the water entering the reservoir after the float switch initiates the pump is removed from the reservoir, but not included in the volume calculation. If the reservoir fill rate is relatively slow as compared to the pump rate, then this error is minimal. If the drain pan is used

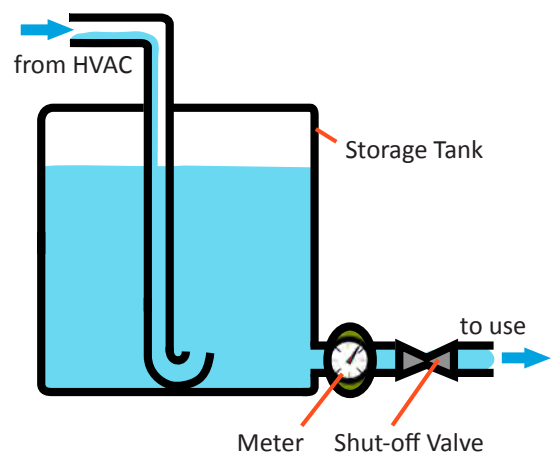

Figure 9.9 Schematic of meter located at exit of water storage tank

as the reservoir in conjunction with the condensate pump option for the drain seal, no additional pumps or float switches are required, only a counter and calibration.

Meter at exit of water storage tank

An alternative to measuring the condensate passing through the drain line is to measure the amount of condensate at the point-of-use by a meter mounted at the exit of a water storage tank, as shown in Figure 9.9. However, measurements at the point-of-use indicate rate of use rather than rate of production of condensate and therefore do not account for condensate lost to tank overflow. This is further complicated if the water storage tank holds water from multiple sources, such as rainwater and condensate, in which case additional metering is required to differentiate the rate of water collected from each source. Whether the loss in accuracy and precision is an acceptable trade-off for easier implementation of this method of metering must be determined on a case-by-case basis.

Comparison of metering options

Table 9.4 shows the common metering options used to measure condensate rate and the associated characteristics of each option.

The only meter that does not require power to display the flow measurement is the positive displacement meter with only a dial indicator. Digital displays require at least a battery source of power. If an electrical signal is used to transfer flow data to a central monitoring station, such as a Building Automation System (BAS), then at least a category 3 (CAT3) Ethernet cabling is required for low-power consumption and category 5 (CAT5) or above for higher power consumption, per the IEEE 802.3at-2009 Power over Ethernet (PoE) standard (Institute of Electrical and Electronics Engineers 2009). Electrical power beyond that provided by CAT5 cabling is necessary for the metering options employing a pump. Alternatively, meters with integral data loggers and wireless communications are now available for the wireless communication of meter data.

Table 9.4 Summary of common metering options used to measure condensate rate

Metering Options	Meter Characteristics									
	Operable Flow Range (gpm)	Requires Minimum Inlet Pressure	Requires Full Pipe Flow Upstream	Requires Electrical Conductivity (>50 mS/cm)	Requires Power Beyond CAT5	Requires Reservoir & Level Switch	Requires Straight Run Upstream of 5 Pipe Diameters	Requires In-house Calibration & Calculations to Determine Flow Rate	Dial Output Available	Display & Signal Output Feasible
Positive displacement	> 0.25 ^a	●	●						●	●
Electronic	> 0.05	●	●	○			○			●
Reservoir, pump, & meter	all			○	●	●	○			●
Reservoir, pump, & counter	all				●	●		●		●
Automated rain gauge	< 0.05									●

● = yes, ○ = depends on meter selected

^a Although only rated for flow rates greater than 0.25 gpm, this meter functions at lower flow rates. Accuracy measurement at low flow rates are pending (Glawe 2013).

The sharp decrease in performance of the electronic meter below its rated operating range can cause errors in low and intermittent flow conditions, such as gravity-driven flow in condensate drain lines. Therefore, only large facilities with AHUs that create a steady stream of condensate are practical candidates for the installation of electronic meters directly in the drain line without the use of pumps (i.e., gravity driven). Also, the need to increase the conductivity of the condensate water for some electronic meters adds complexity that may deter potential use of this type of meter.

The positive displacement meter functions at flow rates below the rated flow of 0.25 gpm and under intermittent and low-pressure (e.g., gravity-driven) conditions, pending accuracy measurements (Glawe 2013). So, the positive displacement meter is a good candidate to measure the flow rate in gravity-driven condensate drain lines if the lack of documented accuracy of the meter is

not a concern. However, since the positive displacement meters require full pipe flow, achieved in gravity-driven flow by including a depression at the location of the meter (see Figure 9.7), and an air bypass if in sequence with a p-trap, some design work is required. Therefore, positive displacement meters are commonly installed in conjunction with a reservoir and pump to ensure full-pipe flow at the required flow rate at the meter location (see Figure 9.8).

Alternatively, positive displacement and electronic meters can be installed at the outlet of water storage tanks (point-of-use) rather than in the condensate drain line. The disadvantages of this tactic are that any overflow of condensate upstream of the storage tank is not recorded and the meter indicates rate of use rather than rate of production. Furthermore, if the tank contains water from multiple sources, then the point-of-use meter measures water from all the sources, not just condensate.

In addition to power and data requirements, meters also require finite space for installation. Gravity-driven meters require enough vertical space to achieve the necessary hydraulic pressure, while metering options employing a reservoir and pump must have enough space to locate and service a reservoir. An isolation valve (or equivalent) is necessary to redirect the water flow around the meter to facilitate repair, calibration, or replacement of the meter.

The impact of overflow of condensate at any point upstream of the meter in the collection system must be considered when interpreting meter data.

Water Storage Tanks

The IGCC provides detailed requirements for rainwater storage tanks, which can be followed as a guide for condensate alone, or condensate and rainwater collected together. Reclaimed and recycled water tanks and plumbing must ultimately meet the approval of the City of San Antonio and San Antonio Water System (SAWS). Therefore, sharing design concepts with the city and SAWS early in the schematic phase of design is prudent.

Tank materials (requirements for rainwater harvesting)

Storage tanks must be constructed of durable, nonabsorbent, and corrosion-resistant materials compatible with both the tank's contents and the type of disinfection system used to treat the water upstream of the tank and within the tank [IGCC§707.11.7.2]. If collected water is to be treated to potable standards, tanks must be constructed in accordance with the National Sanitation Foundation (NSF) Standard 61 [IGCC§707.11.7.2].

Storage tanks are installed either above or below grade. Above-grade storage tanks must be protected from direct sunlight by using opaque, UV-resistant tank materials such as heavily tinted plastic, fiberglass, lined metal, concrete, wood, or painted to prevent algae growth [IGCC§707.11.7.1]. Alternatively, tanks can be installed in a location with a sun barrier, such as in a garage, crawlspace, or shed [IGCC§707.11.7.1]. Where sustained freezing temperatures occur, provisions must be made to keep storage tanks and related piping from freezing [IGCC§707.9].

Tank location (requirements for rainwater harvesting)

Storage tanks and their manholes must not be located directly under any soil or waste piping or any source of contamination and must be at least 5 horizontal feet from seepage pits and septic tanks [IGCC§707.11.7.1]. Storage tanks must be at least 2 horizontal feet from the critical root zone of protected trees and at least 5 feet from adjoining private lots [IGCC§707.11.7.1].

Tank structural support (requirements for rainwater harvesting)

Water storage tanks must be supported in accordance with the International Building Code (IBC). The primary considerations were outlined well in Section 707 of the 2010 IGCC as follows: (i)

Above-ground storage tanks must be supported on a firm base capable of withstanding the storage tank's weight when filled to capacity. (ii) Underground storage tanks must be designed to withstand earth and surface structural loads without damage and with minimal deformation when filled with water or empty. (iii) Where soil can become saturated, an underground storage tank must be ballasted or otherwise secured to prevent the tank from floating out of the ground when empty. If seismic activity is a concern, consider additional structural measures.



Figure 9.10 Round tank access port with locking lid

Tank size (requirements for reclaimed water)

Return on investment and special circumstances must be considered on a case-by-case basis to determine the optimal tank size for each system (see Chapters 7 and 12). "Combining condensate and rainwater can allow a smaller storage tank (than if only collecting rain alone) since condensate produced at a relatively constant rate can account for water needs that would otherwise require a larger storage tank for rain" (Guz 2005). For this reason, IGCC requires condensate to be collected if other on-site reclaimed water sources, such as rainwater or graywater, are harvested or if water features or fountains are located on-site to which the condensate can be routed [IGCC§703.4]. Additional on-site alternative water sources to consider are stormwater, cooling tower blowdown, reverse osmosis and nanofiltration rejection water, graywater, and foundation drain water (Environmental Protection Agency 2012).

Tank Access (requirements for rainwater harvesting)

A storage tank must be covered to prevent foreign particles from entering the system. At least one access opening must be provided to allow inspection and cleaning of the tank interior

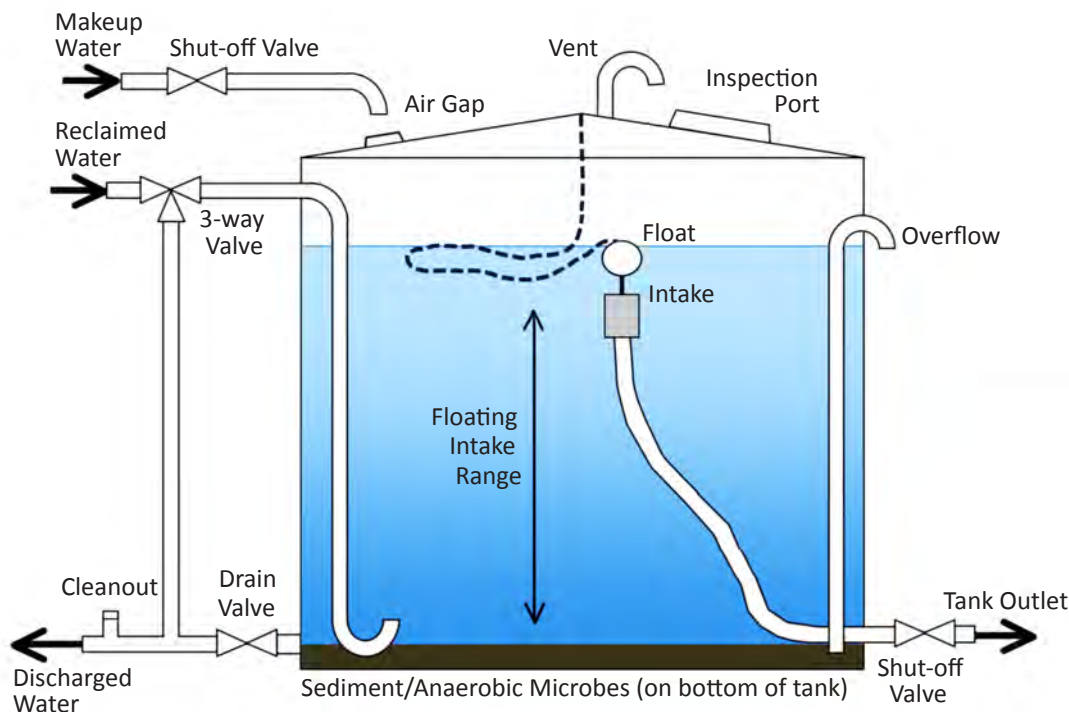

Figure 9.11 Schematic of storage tank inlets, outlets, overflow, vent, and piping (Source: adapted from Mechell et al. 2010 with permission from © Texas A&M Agrilife Extension Service)

[IGCC§707.11.7.5]. All access openings must have an approved locking device or be otherwise protected from unauthorized access [IGCC§707.11.7.5]. Figure 9.10 shows an example of an access port with locking lid.

Below-grade storage tanks located outside of the building must be provided with a square manhole at least 24 inches per side or a round manhole at least 24 inches in diameter [IGCC§707.11.7.5]. Manhole covers on underground tanks must support at least 300 pounds per square foot [GPMCS§505.9.5.4]. Manholes must extend at least 4 inches above ground or must be designed to prevent water infiltration; for example using a gasketed and bolted manhole cover [IGCC§707.11.7.5]. The finished grade must be sloped away from the manhole to divert surface water [IGCC§707.11.7.5]. The exception is storage tanks having a volume less than 800 gallons and installed below grade are not required to have a manhole when provided with a service port that is at least 8 inches in diameter [IGCC§707.11.7.5]. Service ports in manhole covers must be at least 8 inches in diameter, at least 4 inches above the finished grade level, and secured to prevent unauthorized access [IGCC§707.11.7.5].

Tank venting (requirements for rainwater harvesting)

Tanks must be provided with a vent sized in accordance with the IPC and based on the diameter of the tank influent pipe [IGCC 707§11.7.6]. Tank vents must not be connected to sanitary drain system vents [IGCC §707.11.7.6]. Vents must be protected from contamination by means of a U-bend installed with the opening directed downward or by means of an approved cap (see Figure 9.11) [IGCC§707.11.10]. Vent outlets must extend above grade, or as necessary to prevent surface water from entering a (underground) storage tank. The IGCC requires locating the vent outlet a minimum of 4 inches above grade, while the GPMCS requires a minimum of 6 inches above grade with a minimum diameter of 1½ inches [IGCC§707.11.10, GPMCS§505.9.5.8].

Tank inlets and outlets (requirements for rainwater harvesting)

Storage tank inlets must be designed to introduce water into the tank with minimum turbulence and must be located and designed to avoid agitating the contents of the storage tank [IGCC§707.11.7.7]. Turbulence and agitation would stir up sediment at the bottom of the tank and defeat the settling mechanism of the water treatment process. A means must be provided to divert storage tank influent to allow maintenance and repair of the storage tank system [SAPC§1304.3.2]. Outlets must be located at least 4 inches above the bottom of the storage tank and must not skim water from the surface [IGCC§707.11.7.8]. This is commonly achieved by a



Figure 9.12 Tank overflow pipe

floating intake device that rests at the surface of the water and whose travel is limited to avoid reaching the bottom sediment as the tank drains. Water is not skimmed from the surface of the water to avoid drawing in contaminants in the biofilm located at the surface. Figure 9.11 shows a storage tank with examples of acceptable vent, inspection port, inlet, outlet, overflow, drain, and floating intake designs for a combined rainwater and condensate collection system.

Tank overflow and drain (requirements for reclaimed condensate and rainwater harvesting)

The water storage tank must be equipped with an overflow pipe with an area equal to or larger than the sum of the areas of all tank inlet pipes [IGCC§707.11.7.4, GPMCS§505.9.5.5.1].

Although the IGCC permits a pump to be used to drain a storage tank for service or cleaning of a rainwater

harvesting tank, the typical requirement for water storage tanks using water collected on-site is a drain located at the lowest point of the storage tank with an area at least as large as the total area of the overflow pipes [IGCC§707.11.7.9, IGCC§708.12.6.9].

The overflow pipe and drain pipe for a tank containing only condensate must discharge in a manner consistent with condensate reaching the sanitary drain (City of San Antonio 2009). However, if the condensate is commingled with rainwater, a case can be made that when the discharge is predominantly rainwater it can be discharged in a manner consistent with stormwater runoff requirements of the jurisdiction and at a sufficient distance from the tank to avoid damaging the tank foundation, as shown in Figure 9.12 [IGCC§707.11.7.9].

For overflow pipe and drainage pipe leading away from the storage tank to a discharge location, a minimum of one cleanout must be provided on each pipe in accordance with Section 708 of the IPC [IGCC§707.11.7.4, IGCC§708.12.6.9]. Similarly, a backwater valve must be installed on each overflow pipe and drain so that access is provided to the working parts for service and repair [IGCC§707.11.8.1]. The overflow drain line must not be equipped with a shutoff valve [IGCC§707.11.7.4, GPMCS§505.9.5.5].

Protection against entrance of insects, vermin, and debris into tank (requirements for rainwater harvesting)

Inlets, outlets, and vents to the system must be protected against the entrance of insects, vermin, and debris into the storage tanks and piping systems. A close-fitting screen with an aperture no larger than $\frac{1}{16}$ inch must be installed on vent, overflow, and drainage openings to protected against entrance of vermin and insects [IGCC§707.11.10, IGCC§707.7]. Screen materials must be compatible with any system components they are in contact with and must not accelerate corrosion of system components [IGCC§707.7].

Valves (requirements for reclaimed condensate and rainwater harvesting)

All valves except fixture supply control valves must be equipped with a locking feature [SAPC§1304.4, GPMCS§504.9]. A means must be installed at an accessible location on all pipes providing (reclaimed) water to a storage tank to divert storage tank influent and to allow testing, maintenance, and repair of the tank [SAPC§1304.3.2]. Such a bypass mechanism (e.g., a three-way diverter valve) should be installed downstream of fixture traps and vent connections. Labeling the bypass mechanism to indicate direction of flow, connection, and storage tank is a good practice.



Figure 9.13 Air gap between potable or recycled makeup water and reclaim storage tank



Figure 9.14 Double check valve backflow preventer

Makeup Water, Backflow Preventer, and Air Gap

Where an uninterrupted supply of water is required for the intended reclaimed water application, recycled or potable water is typically provided as makeup water. In San Antonio, the municipal recycled or potable water supply must be protected against backflow of the reclaimed water by an air gap and by an approved backflow device, both in accordance with the IPC [SAPC§1304.3.4]. A full-open shut-off valve is commonly included in the makeup water line to allow for testing and maintenance of the reclaimed water system.

See Figure 9.13 for an example of an air gap between the makeup water pipe and the water storage tank. The air gap must be at least double the diameter of the effective opening on the makeup water line and in no case less than 1 inch (City of San Antonio 2012). A requirement for graywater systems can be used as a best practice for condensate systems: the vertical distance between the potable pipe outlet providing makeup water and the overflow pipe must be at least 4 inches [IGCC§708.12.6.4].

See Figure 9.14 for an example of a double-check-valve assembly (DCVA) backflow preventer. Reduced-pressure-principle backflow assembly (R/P or RPZ) is not permitted, because when the R/P functions in a backflow condition it dumps water out on the ground, and technically the Texas Commission on Environmental Quality (TCEQ) considers this an “unauthorized discharge” of recycled or reclaimed water. All backflow preventers must be installed in accordance with the “Backflow Prevention Assembly Installation” standards published in the City of San Antonio Information Bulletin 161 [SAPC§608.13.10]. Precautions must be taken to protect backflow preventers from freezing when installed outside and above ground (City of San Antonio 2012). Outdoor enclosures are a common means of protecting backflow preventers, as they provide security and accessibility for repair [IPC§608.14.1].

To allow for testing, maintenance, and repair of backflow preventer devices, minimum clearances are required during installation, based on the type and position of the device (City of San Antonio 2012). If continuous water service provided by the reclaimed water system is a necessity, a bypass around the backflow preventer must be installed (City of San Antonio 2012).

The owner or owner’s agent must have the backflow prevention assemblies tested by a State of Texas licensed backflow assembly tester at the time of installation, repair, or relocation, and at least on an annual schedule thereafter, or more often when required by the code official [SAPC§608.13.12]. The periodic testing must be performed in accordance with Chapter 34, Article VI, Division 8, of the City Code of San Antonio, TX [SAPC§608.13.12].

Water Level Sensors and Indicators

Water level sensors are used to determine when the water in the tank reaches a predetermined level, at which time the control system executes an action such as opening a fill valve connected to potable or recycled makeup water to meet the water demand that the reclaim water cannot meet at that time. For example, when the water level in a storage tank decreases to $\frac{1}{4}$ the volume of the tank, the water level sensor may act to open a fill valve



Figure 9.15 Purple quick-disconnect valve in purple valve box with valve key in place and connected to a compatible hose

to allow potable or recycled makeup water from the city to fill a tank half full to satisfy immediate water needs. Alternatively, the water level sensor helps prevent makeup water from filling the water tank above the overflow level. A good practice is to include a warning mechanism that alerts the facility personnel if the makeup water continues to fill the tank after the water reaches the overflow level.

Water level indicators provide a visual description of the water level in a storage tank. These are typically simple mechanical systems that rely on a float in the tank to track the water level and a connected rope and pulley system to display the level on a vertical scale mounted on the outside of the tank.

Quick Disconnects Versus Hose Bibs

Locked quick-disconnect assemblies (see Figure 9.15) are used instead of standard hose bibs in areas accessible to the public to protect against accidental misuse of reclaimed and recycled water [GPMCS§503.91]. Quick-disconnect assemblies protect against unauthorized water use in two ways. First, quick-disconnect assemblies require a special tool (key) to enable (unlock) the associated valve to be turned on and off. Second, only hoses fitted with a compatible end connection can be used with the quick-disconnect assemblies, thereby preventing the use of standard hoses. Quick disconnects (and below-grade vaults) must be colored purple [TAC§210.25, SAPC§1304.4].

Per the Texas Administrative Code (TAC), if standard hose bibs are used for reclaimed water, they must be located in locked, below-grade vaults, clearly labeled as non-potable (e.g., “RECLAIMED WATER, DO NOT DRINK”) in both English and Spanish, colored purple, and designed to prevent connection to a standard water hose [TAC§210.25].

Appurtenances

The reclaimed/recycled water system and the potable water system within the building must be provided with the required appurtenances (e.g., valves and bypasses) to allow for deactivation or drainage as may be required for inspection and repair [SAPC§1304.3.2]. All appurtenances located within a wall must have an access hole at least 12 inches x 12 inches and be protected by a door (see Figure 9.16) [SAPC§1304.7.3]. Buried appurtenances, such as valves, must be housed in purple valve boxes, as illustrated in Figure 9.15.



Figure 9.16 Appurtenance access in building wall with door open and proper signage

Valve Seals

Per the SAPC, each valve or appurtenance must be sealed in a manner approved by the code official after the reclaimed/recycled water system has been approved and placed into operation. These seals must either be a crimped lead wire seal or a plastic breakaway seal, which, if broken after system approval, will be deemed conclusive evidence that the reclaimed/recycled water system has been accessed. The seals must be purple, with the words “RECLAIMED WATER,” and should be supplied by the reclaimed/recycled water purveyor or by other arrangements acceptable to the code official [SAPC§1304.7.4]. A common alternative is to provide a locking mechanism on the valve handle, such as a chain and padlock combination, that prevents the valve from being turned to the on position. This is easier than resealing frequently used valves after each use.

Cleanouts

An additional cleanout must be provided in a drainage line for each aggregate horizontal change of direction exceeding an angle of 135 degrees [SAPC§708.3.3].

Distribution Pumping and Control System

Mechanical equipment such as pumps, valves, and filters must be accessible and removable in order to perform repair, maintenance, and cleaning. Pressurized water must be supplied within the pressure range specified by the IPC for the intended application, with pressure-reducing valves installed, as required, in accordance with the IPC [IGCC§708.12.9]. Likewise, distribution pipe must conform to the materials, joints, and size requirements of the IPC [IGCC§709.9].

Treatment System

The common treatment systems for condensate (and rainwater) are sedimentation, filtration, ozonation, UV exposure, chlorination, and adsorption. Advanced oxidation processes (AOPs) are used for higher water purification requirements. Sedimentation and chlorination occur in the storage tank, while filtration, UV exposure, and adsorption are typically located between the water storage tank and the point-of-use. Ozonation is commonly located adjacent to the storage tank so that water can be drawn from the tank, ozonated, and returned to the tank in a closed-loop system. See Chapters 4–6 for details on water treatment systems.

References

- American Society of Heating, Refrigerating, and Air-Conditioning Engineers. 1989. *ASHRAE Standard 62-89R: Ventilation for Acceptable Indoor Air Quality*. Paragraph 5.6.4. Atlanta, GA.
- American Society of Heating, Refrigerating, and Air-Conditioning Engineers. 2011. *ANSI/ASHRAE/USGBC/IES Standard 189.1-2011: Standard for the Design of High-Performance Green Buildings*. Atlanta, GA.
- Brusha, R. F. 2001. "Condensate Traps for Cooling Coils." *HPAC Heating, Piping, Air Conditioning Engineering*, 73(10): 44-46.
- Buzzle. "Distilled Water pH Level." <www.buzzle.com/articles/distilled-water-ph-level.html> Accessed 14 March 2013.
- City of San Antonio. 2009. *Information Bulletin 163 on Condensate Collection—City Code 34-274.1*.
- City of San Antonio. 2011. *San Antonio City Code*, Chapter 10, Article VII: Mechanical Code [SAMC], per Ordinance 2011-12-01-0984.
- City of San Antonio. 2011. *San Antonio City Code*, Chapter 10, Article IX: Plumbing Code [SAPC], per Ordinance 2011-12-01-0984.
- City of San Antonio. 2012. *Information Bulletin 161 on Backflow Prevention Assembly Installations (Revised)*. <<https://webapps1.sanantonio.gov/dsddocumentcentral/upload/backflow.pdf>> Accessed 20 July 2012.
- City of San Antonio. 2013. *San Antonio City Code*, Chapter 34, Article IV: Water Conservation and Reuse [SAWCR], per Ordinance 2013-02-07-0082.
- Elster AMCO Water Corporation. 2012. Personal communication. <www.elsteramcowater.com>
- Environmental Protection Agency. 2012. *WaterSense at Work: Best Management Practices for Commercial and Institutional Facilities*. Washington, DC.
- Glawe, Diana D. 2013. Engineering Science Department. Trinity University. San Antonio, TX. Personal communication.

- Guz, Karen. 2005. "Condensate Water Recovery." *ASHRAE Journal*, 47(6): 54-56.
- Institute of Electrical and Electronics Engineers. 2009. *IEEE Standard 802.3at-2009 Amendment 3: Data Terminal Equipment (DTE) Power via the Media Dependent Interface (MDI) Enhancements*. New York, NY.
- International Association of Plumbing and Mechanical Officials. 2012. *2012 Green Plumbing and Mechanical Code Supplement [GPMCS]*.
- International Code Council. 2010. *2010 International Green Construction Code [IGCC]*
- International Code Council. 2011. *2012 International Mechanical Code [IMC]*.
- International Code Council. 2011. *2012 International Plumbing Code [IPC]*.
- International Code Council. 2012. *2012 International Green Construction Code [IGCC]*.
- Mechell, Justin, Billy Kniffen, Bruce Lesikar, Douglas Kingman, Fouad Jaber, Rachel Alexander, and Brent Clayton. 2010. *Rainwater Harvesting: System Planning*. B-6240. College Station: Texas A&M Agrilife Extension Service.
- Mueller Systems, LLC. 2012. Personal communication. <<http://muellersystems.com>>
- National Sanitation Foundation. 2011. *NSF/ANSI 61-2011: Drinking Water System Components—Health Effects*. Ann Arbor, MI.
- Spectrum Technologies, Inc. 2011. Personal communication. <www.specmeters.com>
- Texas Commission on Environmental Quality. *Texas Administrative Code [TAC]*, Title 30, Chapter 210. <www.sos.state.tx.us/tac/> Accessed 20 July 2012.
- Trent, Warren. 2011. Trent Technologies, Inc. Personal communication. <www.trenttech.com>
- Trent, Warren C., C. Curtis Trent, and Hudy C. Hewitt. 1998. "Condensate Control." Sections 2.31-2.3.30 in *HVAC Systems and Components Handbook*, edited by Nils R. Grimm and Robert C. Rosaler. New York: McGraw-Hill.

10

Labeling and Signage

Effective labeling and signage serves to promote human health and safety and to facilitate the operation and maintenance of a reclaimed water (e.g., condensate and/or rainwater) system. It is a good practice to mark the system in such a way that identification is clearly visible from any reasonable line of sight along the path of the reclaimed water flow from the source to the point-of-use. This chapter provides an overview of code requirements and best practices related to labeling and signage for on-site reclaimed water systems, including those using San Antonio Water Systems (SAWS) recycled water as makeup water.

The San Antonio code official must formally approve the labeling and signage before the reclaimed water system is permitted to operate inside city limits (ICL). The San Antonio code official has the authority to issue variances and require modifications and/or additions during the permitting process.

Outside city limits (OCL) and beyond extra-territorial jurisdiction (ETJ), SAWS requires that a customer service inspection be performed by a licensed customer service inspector (CSI) or water supply inspection specialist (WSPS). This includes inspection of labeling and signage. The record is required and held on file by the Texas Commission on Environmental Quality (TCEQ) for 10 years.

Identification of Recycled Water Piping from SAWS Supply to Point-of-Use

In many cases the point-of-use for SAWS recycled water is at the reclaimed water storage tank, since recycled water is commonly used as makeup water for reclaimed water systems. Recycled water must be identified by the building owner from the point at which it connects to a SAWS recycled water supply pipe (i.e., at the SAWS meter) to the point-of-use. These are considered distribution pipes.

Labeling requirements are the same for pipes carrying recycled and reclaimed water (Information Bulletin 178). Per the San Antonio Plumbing Code (SAPC), recycled/reclaimed pipe and fittings must be continuously wrapped in purple (Pantone color 512) tape that is at least 2 inches wide and 0.0005 inches thick. The purple tape must be fabricated of polyvinyl chloride with a synthetic rubber adhesive and a clear polypropylene protective coating, or an approved equal such as Mylar. The tape must be imprinted in nominal ½-inch-high black uppercase letters with the words “CAUTION: RECLAIMED WATER, DO NOT DRINK.” The lettering must be imprinted in two parallel lines, such that after wrapping the pipe a full line of text is visible in intervals not to exceed 3 feet (see Figure 10.1).



Figure 10.1 Purple tape with integral label wrapped around pipe

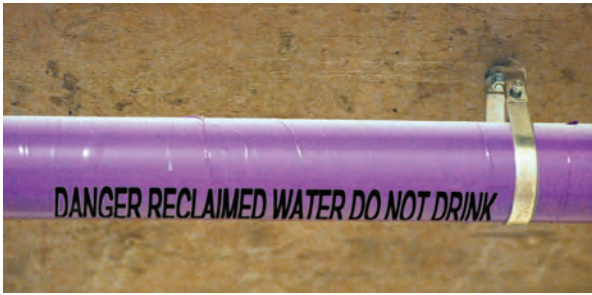

Figure 10.2 Purple label affixed along pipe length, over purple tape wrapped around pipe

Since the SAPC is governed by “common sense,” the San Antonio code official regularly approves variations that are equally effective. For example, affixing the warning label in an orientation along the length of the pipe (see Figure 10.2) is more practical for small pipes where wrapping the label around the pipe, as in Figure 10.1, would obscure the warning text and require multiple loops around the pipe to make one full line of text visible.



Figure 10.3 Purple sleeve around buried pipe and pipe with integral purple color

Buried pipe may alternatively be PVC pipe manufactured with purple color integral to the PVC (see Figure 10.3) and marked on opposite sides to read “CAUTION: RECLAIMED WATER, DO NOT DRINK” at intervals not to exceed 3 feet. The reason PVC pipe with integral purple color is not used above ground is that the integral color fades when PVC pipe is exposed to ultraviolet (UV) light. A recent addition to color identification for buried pipe is a pipe sleeve, as shown in Figure 10.3. It is much quicker and cheaper to slip a pipe sleeve over the pipe than to wrap the pipe.

Another option to save cost is to run the color-coded identification label (Mylar is commonly used) lengthwise along the top of the buried pipe and tape it firmly to the pipe at intervals using PVC tape, as shown in Figure 10.4.

A good practice to help locate buried recycled/reclaimed water lines in the future is to add a standalone warning banner “CAUTION: BURIED RECLAIMED WATER LINE BELOW” at a depth of 18 inches below ground running directly above the buried recycled/reclaimed water pipe, as shown in Figure 10.5.



Figure 10.5 Purple warning label indicating reclaimed water pipe buried below



Figure 10.4 Color-coded purple label run lengthwise along top of pipe and taped firmly to pipe at regular intervals

CPVC and PEX pipe manufactured with purple color integral to the pipe is also an acceptable means of pipe identification within the building, where not exposed to UV light, as long as it is properly labeled at intervals not to exceed 3 feet and the joints are wrapped with the aforementioned purple vinyl tape.

Identification of Reclaimed Water Piping from Source to Storage Tank

Labeling the drainage pipe carrying reclaimed water from the source to the storage tank at any point where the source is not obvious is recommended (but not required) to facilitate maintenance.

For condensate, this means labeling the condensate drainage pipe anywhere between the air-handling unit (AHU) and the water storage tank that the pipe cannot be easily traced back to the AHU. The most common label on the drainage pipe between the AHU and the water storage tank is “CONDENSATE” in black letters on a yellow background with an arrow showing the direction of the flow, placed at reasonable intervals along the pipe (see Figure 10.6). Black letters on yellow background is the designated color identification scheme for non-potable water (City of San Antonio 2012). Common locations are in the vicinity of pipe penetrating a wall or the floor and near valves, pumps, and storage tanks.

For rainwater, this means labeling the rainwater drainage pipe between the gutter and storage tank anywhere the pipe cannot be easily traced back to the gutter. As a rule of thumb, if the flow path from the source to the pipe location is not easily traceable, the pipe should be labeled at that location. This suggests that all buried drainage pipe carrying reclaimed water to a storage tank should be labeled.

Identification of Reclaimed Water Piping from Storage Tank to Point-of-Use

Pipes carrying reclaimed water from the storage tank to the point-of-use must follow the same guidelines as pipes carrying recycled water outlined in the section “Identification of recycled water from source to point-of-use” (SAPC). These are considered distribution pipes.

Identification of Reclaimed/Recycled Water Appurtenance and Point-of-Use

At the point-of-use, such as at urinals, signs identifying the use of reclaimed/recycled water in the plumbing must be clearly visible to all intended users (see Figure 10.7). Likewise, equipment and appurtenances related to the reclaim system must be clearly identified as such via appropriate signage, as outlined



Figure 10.6 Condensate drainage pipe between AHU and storage tank



Figure 10.7 Sign at entry to bathroom using reclaimed water to flush water closet and urinals

Table 10.1 System labeling and signage requirements for non-residential reclaimed water in San Antonio

Location	Identification Text	Lettering and Background	Comments
Above-ground drainage pipes between source and storage tank	Identifies source: CONDENSATE, RAINWATER, RO WATER, etc.	Black letters on yellow tape indicating non-potable water (Information Bulletin 178)	Recommended for maintenance, but not required on reclaimed water drainage pipe. Include arrow to indicate direction of flow. Commonly labeled near wall penetrations, valves, pumps, and storage tanks.
Above-ground pipes between storage tank and point-of-use	CAUTION: RECLAIMED WATER, DO NOT DRINK.	Nominal ½" black letters on purple tape	Pipe wrapped continuously in purple tape. Text appears at intervals not to exceed 3 feet [SAPCS1304.4]. See Figure 10.2. Alternatively, inside buildings, CPVC pipe manufactured with integral purple color can be used in most cases in lieu of wrapping pipe with purple tape; labeling still required.
Buried drainage pipes between source and storage tank	Identifies source: CONDENSATE, RAINWATER, RO WATER, etc.	Black letters on yellow background	Recommended for maintenance, but not required on drainage pipes.
Buried PVC pipes between storage tank and point-of-use	CAUTION: RECLAIMED WATER, DO NOT DRINK	Black lettering on purple PVC pipe or purple tape	Wrapping tape is not required if PVC pipe is manufactured with purple integral to the plastic or if a purple sleeve is used; warning text must appear at least every 3 feet along pipe on opposite (both) sides [SAPCS1304.4]. See discussion in Chapter 10 for alternatives and best practices.
Fixtures	NA	Purple tape	Fixtures wrapped continuously in purple tape [SAPCS1304.4] or purple integral to fixture material.
Equipment room	Caution—Reclaimed water. Do not drink. Do not connect to drinking water system.	1" (min) letters on purple background; sign	Equipment room containing reclaimed/recycled water [SAPCS1304.7.2].
In proximity of equipment	NOTICE: CONTACT BUILDING MANAGEMENT BEFORE PERFORMING ANY WORK ON THIS WATER SYSTEM.	1" (min) letters on purple background; sign	Must be visible to anyone working on or near reclaimed/recycled water equipment [SAPCS1304.7.2].
Mechanical equipment	NA	Purple paint	All equipment appurtenant to reclaimed/recycled water must be painted purple [SAPCS1304.4].
Wall-mounted access doors, hatches, etc.	Caution—Reclaimed water. Do not drink. Do not connect to drinking water system.	½" black letters on a purple background; approximately 6"x6" sign	Each reclaimed/recycled water appurtenance within a wall, such as a valve, must have its access door, hatch, etc. in the wall fitted with a warning sign. The sign must hang in the center of the access door/hatch frame [SAPCS1304.7.3].
Valve seals	RECLAIMED WATER	Letters on purple background; seal	Purple reclaimed/recycled valve seals are provided by the water purveyor or by arrangements acceptable to the city code official. Seals must either be a crimped lead wire or plastic breakaway seal [SAPCS1304.7.3]. Alternatively, valve access can be restricted by a locking mechanism or a quick coupler requiring the right size key.
Water closet and urinal entrance	To conserve water, this building uses reclaimed water to flush toilets and urinals.	½" letters of highly visible color on contrasting background sign.	Number and location of signs must be approved by the city code official or duly appointed representative [SAPCS1304.7.1]. See Figure 10.7.
Outlets: Hose connections, open-ended pipes, and faucets	Nonpotable—not safe for drinking. [SAPCS608.8; TAC§210.25]	½" min black letters on purple background 8"x8" (min) sign [TAC§210.25]	The warning can instead be printed on a tag or indelibly on the fixture [IPC§608.8]. Hose bibs are not permitted on recycled water [SAPCS1304.3.1]. Use quick couplers (Figure 9.15) instead of hose bibs for reclaimed and recycled water to prevent incidental unsafe use of the non-potable water.
Water storage areas and tanks	Reclaimed water. Do not drink. [TAC§210.25]	½" min letters [IGCC§707.11.7] Color not specified, assumed purple; 8"x8" (min) sign [TAC§210.25] or directly on tank [IGCC§707.11.7]	Sign must include warning repeated in Spanish [TAC§210.25]. Alternative to signage is to locate reclaimed/recycled water storage in secured area to prevent public access [TAC§210.25]. See Figure 10.9. Mark (rainwater) storage tank with its rated capacity [IGCC§707.11.7.10].



Figure 10.8 Pictographs for (a) DO NOT DRINK [IGCC 706.2] and (b) DO NOT DRINK THE WATER [TAC210.25 (b) (1), GPMCS§503.9]



Figure 10.9 Sign identifying reclaimed and recycled water combined in a storage tank

in Table 10.1. All signs must be made of corrosive-resistant waterproof material [IPC§608.8]. Repeating the written warnings in Spanish and/or including a pictograph like those shown in Figure 10.8 serves to reinforce the warnings written in English, as shown in Figure 10.9. Appurtenances must be purple as shown in Figures 9.14, 9.15, and 9.16 (see Chapter 9). The purple color can either be integral to the material or achieved by wrapping with purple tape or by painting purple.

Arrows indicating the direction of water flow are not currently required, but are a good practice in proximity to inlets, outlets, and valves to facilitate operations and maintenance. Likewise, labeling the tank with its storage capacity and installing a reclaimed water level indicator on the tank is recommended.

Table 10.1 summarizes the labeling and signage requirements for reclaimed water in San Antonio. Small variations in the warning text are evident in various codes and standards. However, each version of the warning text effectively warns the public with the statement “DO NOT DRINK” in reference to the water source. The color purple in Table 10.1 refers specifically to Pantone color 512 [SAPC§1304].

References

- City of San Antonio. 2011. *San Antonio City Code*, Chapter 10, Article IX: Plumbing Code [SAPC], Ordinance 2011-12-01-0984.
- City of San Antonio. 2012. *Information Bulletin 178 on Color Coding Guide for Pipe Labeling for on Premise Water System Applications* (Revised). < <https://webapps1.sanantonio.gov/dsddocumentcentral/upload/IB178.pdf>> Accessed 20 July 2012.
- International Association of Plumbing and Mechanical Officials. 2012. *2012 Green Plumbing and Mechanical Code Supplement [GPMCS]*.
- International Code Council. 2011. *2012 International Plumbing Code [IPC]*.
- International Code Council. 2012. *2012 International Green Construction Code [IGCC]*.
- Texas Commission on Environmental Quality. *Texas Administrative Code [TAC]*, Title 30, Chapter 210. < www.sos.state.tx.us/tac/> Accessed 20 July 2012.

11

Testing, Inspection, and Maintenance

An initial test of the condensate system performance is recommended before the system is put into operation (i.e., commissioning). This ensures that the system is operating as designed before it is turned over to the facilities personnel. Subsequent testing, inspection, and maintenance is necessary to ensure that the system continues to operate as it was designed.

Although the actual air-handling unit (AHU) is not included in this manual as a design consideration, the cooling coils should be visually inspected at least once a year and cleaned with pressurized hot water and a mild detergent as necessary. Significantly fouled coils have been found to contain wet sludge. Typically, this material is biologically active and must be removed from the airstream to avoid potential indoor-air-quality (IAQ) problems (Williams 2005). When cleaning the cooling coils, divert the wastewater away from the condensate collection tank, or direct application, to avoid contaminating the reclaimed water.

Once proper operation of the cooling coils and drip pan is verified, the system components located outside the AHU should be checked. If standing water and biological matter are detected in the drain pan, chances are the drain-system seal has failed. See Table 9.2 in Chapter 9 for a summary of drain-system seal failure modes. If the condensate is used as makeup water for a cooling tower, a pipe may be the only component between the drain seal and the point-of-use. Other applications are more complex and employ pumps, tanks, valves, and level controls. Since each system is unique, it is recommended that every component from the drain-system seal to the point of application be inspected according to the frequency schedule in Table 11.1. Inspect any components not listed in Table 11.1 at least once a year.

Clear condensate water flowing through the system is a good sign. However, it is not a guarantee that the system is functioning properly. The water quality must be tested annually to ensure that the water treatment process is delivering water at least to the minimum standards required by code for the intended application (see Chapter 2). If a UV filter is used to disinfect the condensate, the effective lifespan is typically a bit over 12 months. However, it is a common practice to change the lamps on a regular 12-month cycle during the annual inspection. Filters used in the water treatment system must likewise be replaced at least as frequently as recommended by the manufacturer.

The fact that water is reaching the intended application is no guarantee that the water is condensate from the AHU if the system allows the use of makeup water from other sources. For example, if the water storage tank level indicator fails or the control system is in error, excess makeup water could fill the water storage tank to the point of overflow or unintentional overuse in cases where application frequency is moderated by the availability of reclaimed water (e.g., irrigation during drought). Therefore, the makeup water and overflow control should be checked after initial installation and at least every 12 months.

According to the International Green Construction Code (IGCC), the storage tank should be tested by filling it to the overflow line and leaving it undisturbed for 24 hours to verify that there are no

leaks in the tank. After 24 hours, water should be introduced for 15 minutes to verify proper leak-free drainage of the overflow system. Finally, the makeup water system is observed for proper operation and successful automatic shutoff when the water level reaches the preset tank refill threshold [IGCC§707.12.8]. The makeup water supply piping and reclaimed water distribution piping must be tested for leaks in the same manner as other pressurized piping on-site in accordance with Section 312.5 of the International Plumbing Code (IPC) [IGCC§709.10.1].

Measuring the amount of condensate passing through the system each month is a good indicator that the condensate system is operating properly. Meter data must be reported to SAWS at least on an annual basis if SAWS provided a rebate for the condensate collection system.

See Table 11.1 for a complete list of minimum testing, inspection, and maintenance requirements for the reclaimed condensate water system. This includes inspection of proper labeling and signage (see Chapter 10). Appendix F includes a modified version of Table 11.1 for use as a checklist during inspection and testing by facility personnel. Appendix G includes the procedures for pre-cross-check test, cross-check test, and actions that must be taken should a cross-connection be detected, per San Antonio ordinance.

Table 11.1 Minimum testing, inspection, and maintenance frequency for condensate system

	Maintenance Description	Minimum Frequency	Source
1	Inspect drip pan: water discharging properly, no biological growth in pan. Investigate causes and clean pan if necessary.	After initial installation and at least every 12 months after that	Williams
2	Inspect and clean HVAC cooling coils (if measured pressure drop across coils is greater than 1.5 times the design pressure, consider replacing coil).	At least every 12 months (if connecting condensate system to an existing HVAC unit, then after initial installation as well)	Williams
3	Ensure that drain system seal is functioning properly. See Table 9.2 for list of failure modes.	Every 12 months	
4	Inspect and test reclaimed water lines using same procedure as used for potable water pipe for pressurized or gravity-driven flow, as appropriate.	After initial installation	SAPCS§1304.5 IGCC§709.10 GPMCS§501.11
5	Inspect and clean filters and screens, and replace as necessary.	Every 3 months	GPMCS§501.5
6	Inspect and verify that disinfection, filters and water quality treatment devices and systems are operational.	In accordance with manufacturer's instructions	GPMCS§501.5 SAWS
7	Test water quality per requirements of authority having jurisdiction; include fecal coliform test.	In accordance with authority having jurisdiction. At least every 12 months for condensate alone and at least every 3 months if rainwater is commingled with condensate.	GPMCS§501.5 SAWS TAC§210.35
8	Inspect pumps and verify operation.	After initial installation and every 12 months thereafter	GPMCS§501.5
9	Inspect valves and verify operation.	After initial installation and every 12 months thereafter	GPMCS§501.5
10	Inspect pressure tanks and verify operation.	After initial installation and every 12 months thereafter	GPMCS§501.5

continued

Table 11.1 Minimum testing, inspection, and maintenance frequency for condensate system (cont.)

	Maintenance Description	Minimum Frequency	Source
11	Inspect caution labels and markings.	After initial installation and every 12 months thereafter	GPMCS§501.5
12	Inspect locking devices and verify operation.	After initial installation and every 12 months thereafter	GPMCS§501.5
13	Pre-cross-connection dual inspection prior to cross-connection test by code official and other authorities having jurisdiction per procedures outlined in Appendix G.	After initial installation and every 12 months thereafter	SAPC§1304.5
14	Cross-connection test in the presence of the code official and other authorities having jurisdiction per procedures outlined in Appendix G.	After initial installation and every 12 months thereafter ^a	GPMCS§501.5 SAPC§1304.5.1.2
15	Inspect and test makeup water air gap and backflow preventer; by backflow assembly tester licensed in the State of Texas.	After initial installation and every 12 months thereafter ^a	GPMCS§501.5
16	Inspect and test trap supply water vacuum breaker (if applicable).	After initial installation	
17	Inspect access and clearance for testing, maintenance, and repair of RP devices: all backflow preventers must be readily accessible, as specified by the manufacturer's instructions.	After initial installation	SAPC§608.14.3 IPC§608.14
18	Inspect and test storage tank for leaks and wear as well as inlet/outlet devices and safety features.	After installation and every 12 months thereafter	
19	Read meter and report values to SAWS (required if SAWS provided a rebate for the system).	Read meter month and report to SAWS at least once every 12 months	SAWS
20	Test makeup water and overflow control in storage tank; tank should not overflow by addition of makeup water, nor shall water in the storage tank fall below a predetermined level.	After initial installation and every 12 months thereafter	

^a Unless site conditions do not require, but at least once every 4 years. Code officials may allow alternate testing at institutional buildings.

References

- City of San Antonio. 2011. *San Antonio City Code*, Chapter 10, Article IX: Plumbing Code [SAPC], per Ordinance 2011-12-01-0984.
- International Association of Plumbing and Mechanical Officials. 2012. *2012 Green Plumbing and Mechanical Code Supplement [GPMCS]*.
- International Code Council. 2012. *2012 International Green Construction Code [IGCC]*.
- San Antonio Water System. 2012. Personal communication with the Conservation Department.
- Texas Commission on Environmental Quality. *Texas Administrative Code [TAC]*, Title 30, Chapter 210. <www.sos.state.tx.us/tac/> Accessed 20 July 2012.
- Williams, Gerald J. 2005. "Chilled-Water Cooling Coils." *HPAC Heating, Piping, Air-conditioning Engineering*, 77(11): 28-34.

12

Payback Period

The factors that most influence whether condensate collection is economically justified include geographic location; degree of outdoor air ventilation and infiltration; size, number, and accessibility of air handlers; available rebates; cost of water; availability of water; and the potential uses and location of uses for condensate (Lawrence et al. 2010).

“Commercial-type buildings over approximately 100,000 square feet typically yield enough condensate to justify the expense of installing a condensate-collection system for irrigation, a cooling tower, or on-site water features” (Guz 2005). A recent study shows that San Antonio is one of the top cities capable of producing large amounts of condensate in commercial buildings with a relatively quick payback period (Lawrence et al. 2012). Candidates for high return on investment are low-humidity facilities such as technology manufacturing or pharmacy storage and high-turnover-of-indoor-air facilities such as shopping centers and laboratories.

Economic feasibility is commonly evaluated in terms of payback period. Payback period is equivalent to the number of years it takes for the accrued savings to pay back the cost of the incremental investment. The incremental investment is the initial investment minus the mandatory costs and rebates or incentives, with an adjustment for miscellaneous fees. In the case of a condensate system, the accrued saving equals the cumulative cost of the water if it were purchased from the municipality instead of reclaimed on site, adjusted for operating and maintenance (O&M) expenses. The payback period can be written as Equation 12.1.

Equation 12.1

$$\text{Payback Period} = \frac{\text{incremental investment}}{\text{annual savings}}$$

When calculating the cost of water in San Antonio, assume that water prices will increase 46% over the next five years (McDonald 2011). A trend of a 46% cost increase over 5 years corresponds to an average cost increase of 8% per year. Appendix H shows San Antonio Water Systems’ (SAWS) actual water fees between 2010 and 2012 and projected fees based on an 8% cost increase per year. Appendix H can be used to calculate payback period until new forecasts from SAWS indicate a different rate of increase for water fees, at which time the new rates should be applied.

The shortest payback period for implementation of an on-site reclaimed condensate system is typically for cooling towers because the incremental cost is small and the annual O&M expenses as a result of implementation are negligible. Example 12.1 illustrates calculation of the payback period for a reclaimed water system routing condensate from a 240-ton air-handling unit (AHU) to a cooling tower.

Example 12.1 At the end of 2009, Concord Property Corporation installed a reclaimed water system in their existing headquarters building in San Antonio to collect 224,511 gallons of condensate a year from a 240-ton AHU to use as makeup water in a cooling tower.

The cost to install the retrofitted system was \$2,272, plus in-house labor provided by the owner. The system consists of PVC pipe and two pumps, with associated reservoirs, to transport the condensate to the cooling tower. San Antonio Water System (SAWS) provided a rebate of \$1,136, which reimbursed the building owner for half the expenses, based on an estimated water savings of 6.89 acre-feet of water saved over a 10-year period. SAWS rebates are based on estimated future water savings, with a maximum rebate equal to half the owner's expenses. Had the owner contracted out the labor (estimated at \$750), that cost would have been included in the owner's expenses for the rebate calculation. Details of commercial rebates are provided on the SAWS website <www.saws.org>. Table 12.1 shows the calculation of the payback period using SAWS commercial water and sewage fees for 2010 and 2011, which are included in Appendix H.

Table 12.1 Annual savings for Concord Property Corporation's condensate reclaimed water system

Year	Fee Year	Reclaimed Water (gallons/year)	Water & Sewage Fees ^a (\$/100 gallon)	Water Fee Savings (\$/year)	O&M Expenses (\$/year)	Annual Savings (\$)	Accrued Savings (\$)
1	2010	224,511	0.5027	1,129	0	1,129	1,129
2	2011	224,511	0.5343	1,200	0	1,200	2,328
3	2012	224,511	0.5779	1,297	0	1,297	3,626

^a Based on typical commercial water volume fluctuations as described in Appendix H

The incremental cost of \$1,136 is equal to the cost for pipes and pumps (\$2,272) minus rebates (\$1,136), incentives, and avoided fees. No additional backflow valve is required, so no annual inspection is required and maintenance fees are negligible. Table 12.1 shows the payback period for the incremental cost of \$1,136 to be approximately one year. Thereafter the building owner profits from the increasing annual savings. This short payback period is indicative of the quick return on investment achieved when discharging condensate to a cooling tower as makeup water. Had the owner contracted out the labor (estimated at \$750) the total cost would have been calculated as \$3,022 and the rebate as \$1,511. Repeating the payback period calculation would result in a payback period of 16 months for \$1,511, obtained by interpolating between values of accrued savings for years 1 and 2.

If condensate is used as cooling tower makeup water, the mineral-free condensate dilutes the built-up sediment in the cooling tower more than mineral-laden municipal water would. This reduces the amount of recirculating water that is continuously drained and replenished with clean water to control the level of total dissolved solids (TDS) and prevent potential damage to the cooling tower and associated equipment (Painter 2009). If the amount of water used in this "blowdown" process is decreased significantly by using condensate makeup water, as opposed to city makeup water, this extra water savings can be included in the annual water savings for an even shorter payback period. Similarly, the relatively cool condensate can theoretically increase the efficiency of the evaporative cooling process of the cooling tower.

Using Equation 12.1 with estimated annual savings is generally accepted as a reasonable measure to gauge the feasibility of implementing a condensate system. However, if the inflation rate is high, the payback period extends beyond several years, or the annual savings are uneven, then a more accurate method, which includes consideration of the discount rate, might be considered (Bragg 2011). The discount rate can be assumed to be the corporate cost of capital. More complex reclaimed water systems that include water storage tanks and treatment incur a longer payback period, for which it is appropriate to consider the increase in water rates and the discount rate, as illustrated in Example 12.2.

Example 12.2 In 2012 Trinity University opened a new building called the Center for Sciences and Innovation. This building includes an on-site reclaimed water system that collects condensate from a 250-ton AHU and combines it with wastewater from an 8,600 gpd reverse osmosis system to flush toilets.¹ Tables 12.2 and 12.3 contain the data required for both the simplest payback calculation and the more complex (and accurate) payback calculation considering forecasted increases in water fees and a discount rate for borrowing funds to complete the project.

Cash flow for each year is equal to the expected water demand in gallons per year multiplied by SAWS water (and sewer) rates, minus annual operation and maintenance expenses. In this example, the expected reclaimed water captured is 2,532,000 gallons per year. The combined water and sewage rate during the first year of implementation (i.e., 2012) is \$0.5779 per 100 gallons within city limits, resulting in the water and sewage cost savings of \$14,632 for the year.² After we subtract \$150 O&M expenses for the annual inspection of the backflow preventer (required by code), the resulting annual savings is \$14,482 for year 1. Table 12.2 shows the annual calculation repeated for each subsequent year after implementation using forecasted water prices and sewage fees from Appendix H.

Table 12.2 Annual savings for Trinity University's reclaimed water system

Year	Fee Year	Reclaimed Water (gallons/year)	Water & Sewage Fees ^a (\$/100 gallons)	Water Fee Savings (\$/year)	O&M Expenses (\$/year)	Annual Savings (\$)	Cumulative Savings (\$)
1	2012	2,532,000	0.5779	14,632	150	14,482	14,482
2	2013	2,532,000	0.6241	15,803	150	15,653	30,135
3	2014	2,532,000	0.6741	17,067	150	16,917	47,053
4	2015	2,532,000	0.7280	18,433	150	18,283	65,335
5	2016	2,532,000	0.7862	19,907	150	19,757	85,093
6	2017	2,532,000	0.8491	21,500	150	21,350	106,442
7	2018	2,532,000	0.9171	23,220	150	23,070	129,512

^a Based on typical commercial water volume fluctuations as described in Appendix H

The \$105,893 incremental cost of the system is equal to the initial costs minus mandatory costs (\$122,226) minus rebates (\$16,333) and incentives from SAWS.

The most simple payback period calculation is equal to the incremental cost divided by the annual savings during the first year of implementation and results in a payback period of 7.3 years. If we account for the forecasted increase in water fees, we see from Table 12.2 that the cumulative water savings repays the incremental investment in about 6 years. This is a shorter payback period because as water gets more expensive the value of reclaiming water and using it on-site increases. Since this project was financed, including a discount rate produces a more accurate estimate of the payback period because the payback period extends beyond a few years.

Table 12.3 includes information for an assumed 5% discount rate and the resulting, more complex, cost calculations. The last column shows that the \$105,893 incremental cost of the system is paid back in about 7 years. The discrepancy between the payback period without consideration of the discount rate (6 years) and that considering a 5% discount rate (7 years) for this example

¹ Data sources: Mechler and Associates and Mission Plumbing.

² Cost estimates per gallon obtained from Appendix G, which assumes usage fluctuating between below base volume up to 150% of base volume at different times of the year.

is 1 year. The discrepancy is expected to increase with higher discount rates and longer payback periods.

Table 12.3 Payback period data for Trinity University's reclaimed water system based on a 5% discount rate

Year	Fee Year	Annual Savings (\$)	5% Discount Rate	Discounted Annual Savings (\$)	Cumulative Discounted Annual Savings (\$)
1	2012	14,482	0.9524	13,793	13,793
2	2013	15,653	0.9070	14,198	27,991
3	2014	16,917	0.8638	14,614	42,604
4	2015	18,283	0.8227	15,041	57,645
5	2016	19,757	0.7835	15,480	73,126
6	2017	21,350	0.7462	15,932	89,057
7	2018	23,070	0.7107	16,395	105,453
8	2019	24,927	0.6768	16,872	122,325

The descriptions of terms that follow can be used in conjunction with Equation 12.1 and duplication of Tables 12.2 and 12.3 to calculate payback period for on-site reclaimed water projects.

Initial investment

The initial investment encompasses materials and labor costs associated with the design and installation of the condensate collection and use system. This includes all components from the exit of the drain pan to the point-of-use of the condensate.

Mandatory costs

The payback period would be overestimated if the initial investment alone were used for the incremental investment for a reclaimed water system implemented during new construction. To calculate an accurate incremental investment, one must subtract the cost of the alternative minimum system required per San Antonio City Code [SAWCR§34.274]. The alternative minimum system is one that collects condensate to a single location and discharges it to a sanitary drain. It is composed of the drainage pipe and an air-seal trap. It may also include pumps and reservoirs if the condensate must be elevated to reach the sanitary drain.

The incremental investment for a reclaimed water system added to an existing building equals the initial investment, because the alternative minimum system was already in place and therefore its cost cannot be avoided. For this reason it pays to implement reclaimed water systems during new construction rather than introducing a retrofitted system at a later date.

Initial investment—mandatory costs

Alternatively, instead of calculating the initial investment and mandatory costs separately and then subtracting, the difference in cost can be assessed. This is the cost associated with design and installation of the components added to the condensate collection and drain system to make it a condensate collection and use system. The most likely additions are a storage tank, a water treatment process, and a distribution system to carry the condensate water from the tank to the point-of-use.

Rebates and incentives

SAWS offers rebates for commercial, institutional, and industrial condensate collection and use

systems provided the system remains in use for 10 years or the life of the equipment, whichever is less, and the condensate water is metered and reported annually for 5 years after installation. See “Large-Scale Retrofit Rebate Program” on SAWS website for further details and rebate application (San Antonio Water System 2012). In addition, SAWS may waive impact fees and requirements for irrigation metering, depending on the reclaimed-system design and use of the condensate.

Operation cost, maintenance cost, and fees

Annual operating and maintenance expenses associated with additional components that are required for a condensate collection and discharge system, such as expense of annual inspection of a backflow prevention device, must be subtracted from the annual water savings. Fees that are avoided at the time of implementation, such as impact fees, must be subtracted from the incremental cost.

Incremental investment

The incremental investment is the initial investment, minus mandatory costs, minus applied rebates or incentives.

Discount rate

The discount rate is the interest rate incurred to borrow the funds necessary from a lending institution to implement the system. This rate changes constantly and varies according to loan size and duration. If the system is planned as a capital expense using internal funds, the discount rate may be disregarded.

Annual water savings

This is the cost of the amount of municipal water equivalent to the amount of condensate collected and used. The cost is based on the current commercial rate of potable water, or SAWS recycled water, whichever is appropriate and available at the building location. The cost of water in San Antonio is expected to increase 46% every 5 years (McDonald 2011). Appendix H provides projected water and sewer rates. These projected rates are subject to change based on SAWS updates.

If condensate is used as cooling tower makeup water, the condensate dilutes the built-up sediment in the cooling tower more than potable municipal water and decreases the frequency of flushing the system to remove sediment buildup. If the frequency of flushing the system is decreased significantly by using condensate makeup water, this extra water savings can be calculated and included in the annual water savings.

References

- Bragg, Steven M. 2011. *Cost Accounting: A Comprehensive Guide*. New York: John Wiley.
- City of San Antonio. 2013. *San Antonio City Code*, Chapter 34, Article IV: Water Conservation and Reuse [SAWCR], per Ordinance 2013-02-07-0082.
- Guz, Karen. 2005. “Condensate Water Recovery.” *ASHRAE Journal*, 47(6): 54-56.
- Lawrence, Thomas, Jason Perry, and Tyler Alsen. 2012. “AHU Condensate Collection Economics.” *ASHRAE Journal*, 54(5): 18-25.
- Lawrence, Tom, Jason Perry, and Peter Dempsy. 2010. “Capturing Condensate by Retrofitting AHUs.” *ASHRAE Journal*, 52(1): 48-54.
- McDonald, Colin. 2011. “SAWS Bills May Rise 14.7%.” *San Antonio Express News*, 14 September.
- Painter, Frank L. 2009. “Condensate Harvesting from Large Dedicated Outside Air-Handling Units with Heat Recovery.” *ASHRAE Transactions*, 115(2): 573-580.
- San Antonio Water Systems. “Large-Scale Retrofit Program.” www.saws.org/conservation/commercial/retrofit.cfm Accessed 27 August 2012.

13

Reduction of Carbon Dioxide Emissions

Reducing municipal water use also reduces energy use and the production of carbon dioxide emissions, as described in the following analysis. In 2008, facility-level metering at San Antonio Water System (SAWS) found that the extraction, processing, and distribution of potable water took 1,939 kWh per million gallons, while wastewater treatment took 2,232 kWh per million gallons (Barker 2010). So a total of 4,171 kWh is expended per million gallons of municipal water that is supplied to a facility and then treated as wastewater after use. This is energy that City Public Services (CPS) must provide to SAWS. Reducing the demand for municipal water, and the associated energy to transport and process that water, both reduces the burden on water and energy facilities and postpones or eliminates the need for building new facilities to handle increased demand conserving not only water but also energy. Incidentally, a similar story can be told for energy. Producing energy requires water. This interdependence of water and energy is commonly referred to as “the nexus between energy and water.”

Saving energy can be quantified in terms of carbon footprint. Each kWh produces approximately 6.8956×10^{-4} metric tons of carbon dioxide (Environmental Protection Agency 2010). This means that every million gallons of water delivered in San Antonio produces 1.3 metric tons of carbon dioxide, and every million gallons of wastewater processed produces 1.54 metric tons of carbon dioxide. For a large building that produces an average of one gallon of condensate per minute, using the condensate on-site would save the city 2,192 kWh and 1.15 metric tons of carbon dioxide production per year.

Equations 13.1 and 13.2 are the equations used to estimate the energy saved and reduction in carbon emissions for using reclaimed water on-site instead of potable municipal water in San Antonio.

Equation 13.1

$$\text{Energy Savings} \left(\frac{\text{kWh}}{\text{yr}} \right) = 4171 \times \text{millions of gallons of municipal water saved per year}$$

Equation 13.2

$$\text{Reduced carbon emissions} \left(\frac{\text{metric tons}}{\text{yr}} \right) = 2.84 \times \text{millions of gallons of municipal water saved per year}$$

Example 13.1 To calculate the energy and carbon emissions savings for on-site reclaimed water, respectively, one simply multiplies the energy rate of 4,171 kWh and the carbon reduction rate of 2.84 metric tons of carbon dioxide, both per million gallons of municipal water used and discharged down the sanitary drain, by the amount of reclaimed water used on-site, in units of millions of gallons. For example, the 2,532,000 gallons per year of

reclaimed water used to flush toilets at Trinity University (as described in Example 12.2) would save the City of San Antonio 10,560 kWh per year and reduce carbon emissions by 7.19 metric tons per year.

In addition to reducing carbon emissions, using reclaimed water on-site decreases the demand placed on water and energy utility companies. Decreasing demand reduces the need for the utility companies to pursue new energy and water sources and associated new facilities to support production and waste disposal. Since expenses are passed on to the consumer, reduced demand inevitably helps reduce costs for water and energy consumers.

The Environmental Protection Agency (EPA) is currently developing a handbook titled *Leveraging the Water-Energy Connection—An Integrated Resource Management Handbook for Community Planners and Decision-Makers*, which will address alternative water sources as part of capacity development (Environmental Protection Agency 2012).

References

- Barker, Bill. 2010. "Energy Consumption Associated with Water." Environmental Policy Office, City of San Antonio.
- Environmental Protection Agency. Emissions and Generations Resource Integrated Database. <www.epa.gov/egrid/> Accessed August 2010.
- Environmental Protection Agency. 2012. *2012 Guidelines for Water Reuse*. EPA 600-R-12-618. Washington, DC.

14

Definitions

Unless otherwise noted, the following words and terms shall, for the purpose of this manual, have the meanings shown herein. The definitions are based, in part, on the City of San Antonio codes and regulations and therefore may contradict definitions from other jurisdictions as well as referenced codes, standards, and guidances.

ABS. Acrylonitrile butadiene styrene.

AHRI. Air-Conditioning, Heating, and Refrigeration Institute.

AHU. The air-handling unit (AHU) is the portion of the heating, ventilation, and air-conditioning (HVAC) system that contains the intake air filter, cooling and heating coils, drip pan, and fan. The AHU does not include components of the HVAC system distributed throughout the building, such as ductwork and auxiliary heating and cooling components or drainage pipe.

AIR SEAL. A seal mechanism that prevents air from entering or exiting the HVAC unit through the drain line. Required by code.

ANSI. American National Standards Institute.

APHA. American Public Health Association.

APPROVED. Acceptable to the code official or authority having jurisdiction [IGCC].

ASHRAE. American Society of Heating, Refrigerating and Air-Conditioning Engineers.

AUTHORITY HAVING JURISDICTION. This could be a local, state, or federal official depending on what aspect of the reclaimed water system is under consideration.

AWE. Alliance for Water Efficiency.

BACKWASH/BACKWASHING. The process of cleansing the filter medium and/or elements by the reverse flow of water through the filter [SACC§34.271].

BACKWATER VALVE. A device or valve installed in the system drain piping that prevents drainage or waste from backing up into the system and causing contamination or flooding [IPC].

BASIS OF DESIGN. A document describing a building owner's goals and ideas about a building intended for construction or renovation.

BLOWDOWN. The discharge of recirculating water for the purpose of discharging materials contained in the water, the further buildup of which would cause concentration in amounts that could damage or impair machinery, equipment, or systems [TAC§210.52].

BOD. Biochemical oxygen demand.

BOD₅. Five-day biochemical oxygen demand (BOD₅).

BUILDING-RELATED ILLNESS. Identified symptoms of diagnosable illness that can be attributed directly to airborne building contaminants.

CBOD₅. Five-day carbonaceous biochemical oxygen demand (CBOD₅).

CFM. Cubic feet per minute (cfm).

CFU. Colony Forming Units.

CITY. City of San Antonio, Texas.

COD. Chemical oxygen demand.

CODE. A legally binding set of minimum regulations and requirements.

CODE OFFICIAL. For San Antonio, the Director of the Planning and Development Services Department or a duly authorized representative to act on his or her behalf. The code official shall also be known as the building official [Ordinance 2011-12-01-0984].

CONDENSATE. Liquid that forms when the temperature of a vapor is lowered to its dew point temperature. Air-conditioning systems produce condensate when an airstream contacts cooling coils. As the moisture in the air condenses on the cold surface of the coils, the air is “dehumidified” [IMC].

CONDENSATE COLLECTION SYSTEM. The drain pan, air seal, and piping to a reuse application or drain and any related in-line equipment such as meters, pumps, and valves.

CPVC. Chlorinated polyvinyl chloride. A thermoplastic polymer commonly used to fabricate pipes and fittings for plumbing applications. CPVC withstands higher temperatures and pressures than PVC, so CPVC is commonly used for hot-water applications.

CSI. A licensed customer service inspector. Qualified to inspect on-site piping outside city limits (OCL) and beyond extra-territorial jurisdiction (ETJ).

DOC. Dissolved organic carbon.

DOMESTIC WASTEWATER. Waste and wastewater from humans or household operations that are discharged to a wastewater collection system or otherwise enter a treatment works. This includes waterborne human waste and waste from domestic activities such as washing, bathing, and food preparation. It includes graywater and blackwater that is disposed in an on-site wastewater system [TAC§210.3].

DRAIN PAN. Container that catches condensate dripping from the cooling coils of an HVAC system. Also called drip pan.

DRIP IRRIGATION. An irrigation system (drip, porous pipe, etc.) that applies water at a predetermined controlled low-flow levels directly to the roots of the plant [SACC§34.271].

DROUGHT. Any condition, whether man-made or natural, where the available water supply or resources are not meeting the water demand, or if the water supply or resources are being depleted at a faster rate than they are being replenished [SACC§34.271].

DRY-BULB TEMPERATURE. The temperature indicated by an ordinary thermometer [ASHRAE].

EPA. Environmental Protection Agency.

EQUIPMENT. All piping, ducts, vents, control devices, and other components of systems besides appliances which are permanently installed and integrated to provide control of environmental conditions for buildings. This definition shall also include other systems specifically regulated in this code [IMC].

ETJ. Extra-territorial jurisdiction (ETJ) is the area adjacent to the city of San Antonio city limits where the city has regulatory control as provided by the State of Texas [SACC§34.271].

FIRST FLUSH DEVICE. A device that diverts a predetermined volume of rainwater running off a collection surface, such as a roof, from the storage tank at the beginning of a rain event to prevent the highest concentration of contaminants from the rooftop from entering the water storage tank. Also referred to as a roof washer.

GPD. Gallons per day (gpd).

GPH. Gallons per hour (gph).

GPM. Gallons per minute (gpm).

GPMCS. Green Plumbing and Mechanical Code Supplement published by IAPMO.

GRAIN. A unit of measure of mass. One pound mass equals 7,000 grains.

GRAYWATER. Untreated wastewater that has not come into contact with wastewater from toilets, urinals, kitchen sinks, or dishwashers. Graywater includes but is not limited to wastewater from bathtubs, showers, hand-washing sinks, clothes washers, and laundry trays [IPC]. Graywater does not include wastewater from the washing of materials soiled with human excreta or hazardous/toxic ingredients [TAC].

HOSE BIB. A threaded faucet connection for such devices as a garden hose or washing machine.

HVAC SYSTEM. Heating, ventilating, and air-conditioning (HVAC) systems are composed of the air-handling unit (AHU), ductwork, auxiliary heating and cooling components, drainage pipe, and any related apparatus installed for the purpose of distributing conditioned air to a room, space, or area. The air-conditioning system is integral to the HVAC system.

IAPMO. International Association of Plumbing and Mechanical Officials.

IBC. International Building Code, published by the ICC.

ICC. International Code Council.

ICL. In city limits.

IGCC. International Green Construction Code, published by ICC.

IMC. International Mechanical Code, published by the ICC.

INDUSTRIAL RECLAIMED WATER. A non-domestic or non-municipal wastewater.

INLET FILTER. A screen, grid, or other device installed on a gutter, on a downspout system, or at another location upstream of the storage tank. The filter passes liquids and retains solids [IGCC].

IPC. International Plumbing Code, published by the ICC.

L. Liter (l).

LEED. Leadership in Energy and Environmental Design. LEED is an internationally recognized green building certification system developed by the US Green Building Council (USGBC).

LOCAL JURISDICTION. San Antonio (for the content of this manual).

MAKEUP WATER. Water used to “make up” the difference between demand and other supply sources.

MAL. Maximum allowable level.

METER. A water volume measuring device used to collect data and indicate water usage abnormalities. Such devices are provided by the water purveyor or the building owner [IGCC].

MG. Milligram (mg).

ML. Milliliter (ml).

MPN. Most probable number of organisms. Used to quantify growth of microorganisms.

MUNICIPAL RECLAIMED WATER. Wastewater that has been reclaimed, recycled, reused, or treated by a municipality for specific non-potable uses [IGCC]. Also called recycled water for the purposes of this manual per SAPC definition.

MUNICIPAL WASTEWATER. Waste or wastewater discharged into a publicly owned or a privately owned sewage treatment works primarily consisting of domestic waste [TAC§210.3].

MUNICIPAL WATER. Water that has been processed and distributed by a municipality for potable and non-potable uses.

NON-CONTACT COOLING WATER. Water used for cooling that does not come into direct contact with any raw material, intermediate product, waste product, byproduct, or finished product [TAC].

NSF. National Sanitation Foundation.

NON-POTABLE WATER. Water that is not safe for drinking or for personal or culinary utilization [IGCC].

NTU. Nephelometric turbidity units. Measure of turbidity.

OCL. Outside city limits.

ON-SITE. The use of industrial reclaimed water within the boundaries of the industrial facility or within the boundaries of property that is contiguous to the facility and owned or operated by the producer [TAC].

ON-SITE RECLAIMED WATER. Wastewater that has been reclaimed, recycled, reused, or treated to be used within the boundaries of the facility or within the boundaries of property that is contiguous to the facility and owned or operated by the wastewater producer [TAC].

ONCE-THROUGH COOLING. Water passed through main cooling condensers in one or two passes for the purpose of removing waste heat.

PEX. PEX tubing is made from crosslinked high density polyethylene polymer. It is an alternative to metal or hard plastic tubing or pipe used in water distribution systems.

PH. Measure of the hydrogen ion activity in a solution. A pH less than 7 is considered acidic, a pH equal to 7 is considered neutral, and a pH greater than 7 is considered basic or alkaline.

POC. Particulate organic carbon.

POTABLE WATER. Water free from impurities present in amounts sufficient to cause disease or harmful physiological effects and conforming to the bacteriological and chemical quality requirements of the Public Health Service Drinking Water Standards or the regulations of the public health authority having jurisdiction [IGCC].

POUND MASS. Mass required to create 1-pound force at the Earth's surface, using the standard value of 32.174049 ft/s² for the value of gravity.

PPM. Parts per million (ppm).

PREVENTATIVE MAINTENANCE PROGRAM. A program involving scheduled inspection of critical system components to detect impending failures and regular maintenance of specified system components to prevent system failures.

PRIMARY DISINFECTION. The first disinfectant used in a treatment system, with the primary objective of the disinfectant being to achieve the necessary microbial inactivation (Environmental Protection Agency).

PROCESS WATER. Any water that, during manufacturing or processing, comes into direct contact with or results from the production or use of any raw material, intermediate product, finished product, byproduct, or waste product.

PSYCHROMETRIC. Related to the physical and thermodynamic properties of gas-vapor mixtures, such as moist air.

PVC. Polyvinyl chloride. A thermoplastic polymer commonly used to fabricate pipes and fittings for cold-water plumbing applications.

RAINWATER. Water from natural precipitation that was not contaminated by use [IGCC].

RAINWATER COLLECTION AND CONVEYANCE SYSTEM. Rainwater collection system components extending between the collection surface and the storage tank that convey collected rainwater, usually through a gravity system [IGCC].

RECLAIMED WATER. Water from (on-site) sources such as rainwater harvesting, air-conditioning condensate collection, carwashes, ponds, lakes, rivers, or other sources as approved by the code official [SAPC].

RECYCLED WATER. Water that, as a result of a tertiary treatment of domestic wastewater by a public agency, is suitable for a direct beneficial use or a controlled use that would not otherwise occur. The level of treatment and quality of the reclaimed/recycled water is approved by TCEQ [SAPC]. Also called municipal reclaimed water.

REGISTERED DESIGN PROFESSIONAL. An individual who is registered or licensed to practice his or her respective design profession as defined by the statutory requirements of the professional registration laws of the state or jurisdiction in which the project is to be constructed [IGCC].

REGISTERED DESIGN PROFESSIONAL IN RESPONSIBLE CHARGE. A registered design professional engaged by the owner to review and coordinate certain aspects of the project, as determined by the building official, for compatibility with the design of the building or structure, including submittal documents prepared by others, deferred submittal documents, and phased submittal documents [IGCC].

REPAIR. The reconstruction or renewal of any part of an existing building or building site for the purpose of its maintenance [IBC].

RESTRICTED USE. The use in municipal settings where public access is controlled or restricted by physical or institutional barriers, such as fencing, advisory signage, or temporal access restrictions (Environmental Protection Agency).

ROOF WASHER. A device or method for removal of sediment and debris from collection surface by diverting initial rainfall from entry into the storage tank. Also referred to as a First Flush Device [IGCC].

SACC. San Antonio City Code.

SAMC. San Antonio Mechanical Code. Article VII of the Building-Related Codes (Chapter 10) of the City of San Antonio per Ordinance 2011-12-01-0984.

SAN ANTONIO CODE OFFICIAL. The Director of the Development Services Department (DSD) or a duly authorized representative to act on his or her behalf [SAPC]. This representative is typically a plumbing inspector in the Building Development Division of DSD.

SAPC. San Antonio Plumbing Code. Article IX of the Building-Related Codes (Chapter 10) of the City of San Antonio per Ordinance 2011-12-01-0984.

SAWCR. San Antonio Water Conservation and Reuse. Article IV of the Water and Sewers Codes (Chapter 34) of the City of San Antonio per Ordinance 2013-02-07-0082.

SAWS. San Antonio Water System; a public utility owned by the City of San Antonio.

SECONDARY DISINFECTION. The second disinfectant used in a treatment system, with the primary objective of the disinfectant being to maintain the disinfection residual through the distribution system (Environmental Protection Agency).

SILVICULTURE. The act of controlling the establishment, growth, composition, health, and quality of forests and woodlands to meet the diverse needs and values of landowners and society on a sustainable basis (US Forestry Service).

SQ FT. Square foot (sq ft).

STANDARD. A collection of principles and protocols for voluntary adoption, developed through a formal consensus process involving experts in the relevant field.

STORAGE TANK (GRAYWATER OR RAINWATER). A fixed container for holding water at atmospheric pressure for subsequent reuse as part of a plumbing or irrigation system [IGCC].

SU. Standard unit(s). Unit of measure of pH.

SURROGATE. An indicator organism or chemical constituent that when detected signifies the presence or probability of another organism, chemical constituent, or contaminant in the test sample.

TAC. Texas Administrative Code.

TCEQ. Texas Commission on Environmental Quality.

TDS. Total dissolved solids. Generally accepted to be organic and inorganic solids, dissolved in a liquid, that pass through a filter with a 2 micron pore size but will be present after the liquid evaporates.

TERTIARY STANDARDS. Standards, practices, or policies that ensure that wastewater has been treated to achieve a level of quality that is safe for release into the environment, such as, but not limited to, release into seas, rivers, lakes, and the ground [IGCC].

TMY3. The most recent Typical Meteorological Year (TMY) database generated by the National Renewable Energy Laboratory (NREL) for purposes such as building energy modeling.

TSS. Total suspended solids. Generally accepted to be solids indefinitely suspended in a solution that can be filtered out using a filter with a 2 micron pore size.

UNRESTRICTED USE. Use in municipal settings where the public access is not restricted (Environmental Protection Agency).

USGBC. US Green Building Council; a nonprofit association of leaders working to make green buildings available to everyone within a generation. USGBC developed the Leadership in Energy and Environmental Design (LEED) building certification system.

UV. Ultraviolet light. Light with a wavelength between 10 and 400 nanometers (nm). The UV used for disinfection is short-wavelength UV (commonly abbreviated UVC), with a wavelength between 100 and 280 nm.

WASTEWATER. Water resulting from a process or use that is typically disposed of as waste.

WATER FEATURE. An artificially created body of water for aesthetic use including but not limited to fountains, waterfalls, ponds, lagoons, rivers, streams, and brooks [SACC§34.271].

WATER RECLAMATION. The act of treating wastewater to make it acceptable for reuse.

WATERSENSE. A program of the U.S. Environmental Protection Agency (EPA) designed to identify and promote water-efficient products and practices.

WSPS. A licensed water supply inspection specialist. Qualified to inspect on-site piping outside city limits (OCL) and beyond extra-territorial jurisdiction (ETJ).

Appendixes

Appendix A: Threshold Levels for Level I Industrial Reclaimed Water

	Threshold (mg/l)	MAL (mg/l)
Conventionals and Nonconventionals		
Total organic carbon	55	---
Oil and grease	10	---
Total dissolved solids (TDS)	2000	---
Nitrate nitrogen	10	---
Metals		
Antimony, total	0.09	0.03
Arsenic, total	0.030	0.010
Barium, total	0.030	0.010
Beryllium, total	0.015	0.005
Cadmium, total	0.003	0.001
Copper, total	0.030	0.010
Cyanide, free	0.200	---
Lead, total	0.015	0.005
Manganese	0.05	---
Mercury, total	0.0002	0.0002
Nickel, total	0.030	0.010
Selenium, total	0.030	0.010
Silver, total	0.006	0.002
Thallium, total	0.030	0.010
Zinc, total	0.015	0.005

(Source: TAC §210.53(a)(9))

Reference

Texas Commission on Environmental Quality. *Texas Administrative Code [TAC]*, Title 30, Chapter 210. <www.sos.state.tx.us/tac/> Accessed 20 July 2012

Appendix C: Common Waterborne Pathogenic Microorganisms

	Microorganism	Disease: Symptoms	Sources
Bacteria	<i>Campylobacter</i>	Gastroenteritis, reactive arthritis	Fecal matter of animals, particularly birds.
	<i>Escherichia coli</i>	Gastroenteritis and septicemia, hemolytic uremic syndrome (HUS): Nausea, diarrhea, abdominal pain	Fecal matter of all animals, but types pathogenic to humans are mostly found in human and cattle feces
	<i>Legionella</i>	Legionellosis or Legionnaires' disease: respiratory illness, pneumonia	Naturally occurring in water but thrives at temperatures between 77° and 113°F.
	<i>Salmonella</i>	Salmonellosis: Headache, chills, vomiting, diarrhea, fever	Fecal matter of animals, including birds and reptiles.
	<i>Vibrio cholerae</i>	Cholera: Life-threatening diarrhea	
Protozoa	<i>Cryptosporidium</i>	Cryptosporidiosis: Diarrhea, nausea, abdominal cramps, fever	Fecal matter of animals, but mice and birds are not believed to carry the human pathogen species
	<i>Giardia</i>	Giardiasis: Diarrhea, nausea, abdominal cramps	Fecal matter of infected animals
	<i>Toxoplasma gondii</i>	Toxoplasmosis	Fecal matter of animals, notably cats and rodents; also contained in soil
Virus	Norovirus	Viral gastroenteritis: Vomiting, abdominal cramps, diarrhea, nausea, fever	
	Hepatitis A virus	Hepatitis: Jaundice, fatigue, abdominal pain, diarrhea, nausea	
	Rotavirus	Gastroenteritis: Nausea, diarrhea, abdominal pain	

(Sources: Macomber 2010, EPA 1999)

References

- Environmental Protection Agency. 1999. *Alternative Disinfectants and Oxidants Guidance Manual*. EPA 815-R-099-014. Washington, DC.
- Macomber, Patricia. 2010. *Guidelines on Rainwater Catchment Systems for Hawaii*. Revised Edition. Manoa: College of Tropical Agriculture and Human Resources, University of Hawaii at Manoa.

Appendix D: Condensate Production Prediction (based on typical meteorological year [TMY3] data for San Antonio for 100% outside air flow through AHU with supply air condition of 55°F and 94% relative humidity)

Table D.1 Condensate prediction (in gallons) for various nominal flow rates

Month	1,000 cfm	10,000 cfm	100,000 cfm	200,000 cfm	300,000 cfm	400,000 cfm	500,000 cfm	600,000 cfm
Jan	82	820	8,196	16,391	24,587	32,782	40,978	49,173
Feb	130	1,300	13,000	26,000	39,000	52,000	65,000	78,000
Mar	299	2,989	29,886	59,772	89,659	119,545	149,431	179,317
Apr	996	9,962	99,622	199,243	298,865	398,486	498,108	597,729
May	2,175	21,751	217,508	435,015	652,523	870,031	1,087,538	1,305,046
Jun	2,756	27,556	275,559	551,119	826,678	1,102,237	1,377,796	1,653,356
Jul	2,883	28,825	288,253	576,505	864,758	1,153,010	1,441,263	1,729,516
Aug	2,659	26,590	265,895	531,791	797,686	1,063,581	1,329,477	1,595,372
Sep	2,135	21,351	213,510	427,020	640,529	854,039	1,067,549	1,281,059
Oct	1,222	12,222	122,218	244,437	366,655	488,873	611,092	733,310
Nov	744	7,437	74,369	148,737	223,106	297,475	371,843	446,212
Dec	188	1,881	18,807	37,613	56,420	75,227	94,034	112,840
Annual	16,268	162,682	1,626,822	3,253,643	4,880,465	6,507,287	8,134,109	9,760,930

Table D.2 Condensate prediction (in gallons) for various tonnage systems with nominal operation at 100% total cooling capacity^a

Month	1 ton	10 ton	50 ton	100 ton	200 ton	400 ton	600 ton	800 ton	1,000 ton
Jan	29	287	1,434	2,868	5,737	11,474	17,211	22,948	28,684
Feb	46	455	2,275	4,550	9,100	18,200	27,300	36,400	45,500
Mar	105	1,046	5,230	10,460	20,920	41,841	62,761	83,681	104,602
Apr	349	3,487	17,434	34,868	69,735	139,470	209,205	278,940	348,676
May	761	7,613	38,064	76,128	152,255	304,511	456,766	609,021	761,277
Jun	964	9,645	48,223	96,446	192,891	385,783	578,674	771,566	964,457
Jul	1,009	10,089	50,444	100,888	201,777	403,554	605,330	807,107	1,008,884
Aug	931	9,306	46,532	93,063	186,127	372,253	558,380	744,507	930,634
Sep	747	7,473	37,364	74,728	149,457	298,914	448,371	597,827	747,284
Oct	428	4,278	21,388	42,776	85,553	171,106	256,658	342,211	427,764
Nov	260	2,603	13,015	26,029	52,058	104,116	156,174	208,232	260,290
Dec	66	658	3,291	6,582	13,165	26,329	39,494	52,659	65,823
Annual	5,694	56,939	284,694	569,388	1,138,775	2,277,550	3,416,326	4,555,101	5,693,876

^a Assumed baseflow (Qbase) of 350 cfm per total tons cooling capacity (TON)

Appendix E: Condensate Collection System Design & Implementation Checklist

Phase	✓	Activity	Participant Coordination									
			Architect	Engineer	Landscape	Contractor	Owner	Facilities	SAWS	City	Commissioning	
SCHEMATIC DESIGN		Water demand calculations	O		W							
		Rough reclaim water quantity calculations	O	W	W							
		Schematic drawing of proposed reclaim system	W			R	R	R				
		Flow diagram	W									
		Presentation to stakeholders	W				R	R				
		Capability and limits						O	O			
		Operations and maintenance requirements		W	W				R			
		Preliminary system decisions	O	W	W		A	R				C
DESIGN DEVELOPMENT		Final reclaim water quantity calculations	O		W							
		Final intended use	O	W	W		A					
		Rough tank size	O		W							
		Required treatment		W	W		O	O				
		Coordinate existing utilities	W			C						
		Evaluate compliance with federal, state, district, county, city and neighborhood regulation/ordinances	W	W	W				A	A		C
		Research rebates	W									
		Determine waivers; irrigation meter, impact fees	W		W		O		A			
		Rough cost estimate				W						
CONSTRUCTION DOCUMENTS		Stakeholder meeting	O				A		A	A		O
		Final condensate quantity calculations	O	W	W		A	R	R			R
		Final tank size	W		W							
		Treatment and filtration	O	W		R						
		Pipe sizing	O	W	W							R
		Pump selection	O	W	W			R				
		Pressure tank	O	W								R
		Sequence of operation & control system	O	W	W							R
		Solenoid valves		W	W							
		Meter selection	O	W	W				W			
		Overflow	O	W	W							
		Makeup water	O	W	W						R	

O = Oversight
R = Review

A = Agree/Approve/Decision
C = Coordinate/Communicate

W = Work/Create/Design/Generate

continued

Appendix E *continued*

Phase	✓	Activity	Participant Coordination								
			Architect	Engineer	Landscape	Contractor	Owner	Facilities	SAWS	City	Commissioning
CONSTRUCTION DOCUMENTS (continued)		Air gap & backflow preventers	O	W	W				R	R	
		Ensure compliance with regulations/ordinances	W	W	W			O	O		O
		Commissioning plan	O	R	R		O	O	R		W
		50% design review	W	W	W		A	R	R		R
		90% design review	W	W	W		A	R	R		R
		Calculate final cost				W					
		100% design review	W	W	W				A	A	R
		Permits (city & SAWS)	O				O		A	A	
		Issue project for bid	O				O				
		Select construction contractor	R				A	R			R
CONSTRUCTION		Pre-construction meeting	O			W					
		Review commissioning plan	O	R	R	W	R	R			R
		Pre-functional & functional checklists				W					R
		Trades meeting	O			C					
		Schedule & responsibilities	O	R	R	C					W
COMMISSION		Conduct operational start-up	O	R	R	W					C
		O&M manuals	O	R	R	W	W	W			R
		O&M training	O	R	R	W	W	W			C
		Warranty documents	O			W	R	R			
		Final inspection; backflow, cross-connect	O				W		A	A	
		Rebates issued					W		A		
START-UP O&M		Start-up water quality test					W	W			
		One-year maintenance contract	O			W	W	W			
		Maintenance log					W	W			
		System adjustments during warranty period				W	W	W			
		Report meter data to SAWS (monthly)					W	W			
		Quarterly (see Appendix E for list of items)					W	W			
		Annual (see Appendix E for list of items)					W	W			
		10 -month commissioning review					W	W			C

O = Oversight
R = Review

A = Agree/Approve/Decision
C = Coordinate/Communicate

W = Work/Create/Design/Generate

Appendix F: Test, Inspection, and Maintenance Checklist

Maintenance Description (see Table 11.1 for more complete description and reference source)		Date				
		Initial Installation	1 st Quarter	2 nd Quarter	3 rd Quarter	Annual
1	Inspect drip pan: water discharging properly, no biological growth in pan. Investigate causes and clean pan.	<input type="checkbox"/>				<input type="checkbox"/>
2	Inspect and clean HVAC cooling coils (if measured pressure drop across coils is greater than 1.5 times the design pressure, consider replacing coil).	<input type="checkbox"/>				<input type="checkbox"/>
3	Inspect drain system seal functioning properly. See Table 9.2 for list of failure modes.					<input type="checkbox"/>
4	Inspect and test reclaimed water lines using same procedure as used for potable water pipe for pressurized or gravity-driven flow, as appropriate.	<input type="checkbox"/>				
5	Inspect and clean filters and screens, and replace (if necessary).		<input type="checkbox"/>	<input type="checkbox"/>	<input type="checkbox"/>	<input type="checkbox"/>
6	Inspect and verify that disinfection, filters, and water quality treatment devices and systems are operational.		<input type="checkbox"/>	<input type="checkbox"/>	<input type="checkbox"/>	<input type="checkbox"/>
7	Test water quality to meet minimum requirements, including periodic fecal coliform.					<input type="checkbox"/>
8	Inspect pumps and verify operation.	<input type="checkbox"/>				<input type="checkbox"/>
9	Inspect valves and verify operation.	<input type="checkbox"/>				<input type="checkbox"/>
10	Inspect pressure tanks and verify operation.	<input type="checkbox"/>				<input type="checkbox"/>
11	Inspect caution labels and markings.	<input type="checkbox"/>				<input type="checkbox"/>
12	Pre-cross-connection dual inspection prior to cross-connection test by code official and other authorities having jurisdiction per procedures outlined in Appendix G (Table G.1).	<input type="checkbox"/>				<input type="checkbox"/>
13	Cross-connection test in the presence of the code official and other authorities having jurisdiction per procedures outlined in Appendix G (Table G.2).	<input type="checkbox"/>				<input type="checkbox"/>
14	Inspect and test makeup water air gap and backflow preventer; by licensed backflow assembly tester. ^a	<input type="checkbox"/>				<input type="checkbox"/>
15	Inspect and test trap supply water vacuum breaker (if applicable).	<input type="checkbox"/>				
16	Inspect access and clearance for testing, maintenance, and repair of RP devices: 1' elevation, platform at 5'.	<input type="checkbox"/>				
17	Inspect and test storage tank for leaks and wear as well as inlet/outlet devices and safety features.	<input type="checkbox"/>				<input type="checkbox"/>
18	Read meter and report values to SAWS, required if SAWS provided a rebate for the system.		<input type="checkbox"/>	<input type="checkbox"/>	<input type="checkbox"/>	<input type="checkbox"/>
19	Test makeup water and overflow control in storage tank; tank should not overflow by addition of makeup water, nor should water in the storage tank fall below a predetermined level.	<input type="checkbox"/>				<input type="checkbox"/>

^a Unless site conditions do not require, but at least once every four (4) years. Code officials may allow alternate testing at institutional buildings.

Appendix G: Cross-Connection Test and Detection Plan

Table G.1 Procedures for visual dual system inspection prior to cross-connection test (steps to be conducted by the San Antonio code official and other authorities having jurisdiction) [SAPCS1304.5.1]

1	Check meter locations of the recycled water and potable water lines to verify that no modifications were made and that no cross connections are visible.
2	Check all pumps and equipment, equipment room signs, and exposed piping in the equipment room.
3	Check all valves to ensure that valve lock seals are still in place and intact and check all valve control door signs to make sure no signs have been removed.

Table G.2 Procedure for cross-connection test (steps to be followed by the owner's agent in presence of the San Antonio code official and other authorities having jurisdiction) [SAPCS1304.5.2]

1	Activate and pressurize the potable water system.
2	Shut down and completely drain the reclaimed/recycled water system.
3	Keep potable water system pressurized for the minimum time specified by the code official, which will be no less than one hour, while the reclaimed/recycled water system is empty. ^a
4	Test and inspect all potable and recycle/reclaimed fixtures for flow. –flow from any reclaimed/recycled water system outlet indicates a cross connection –no flow from a potable water outlet may indicate a cross connection.
5	Check for flow at the drain of the reclaimed/recycled water system during and at the end of the test.
6	Completely drain the potable water system.
7	Activate and pressurize the reclaimed/recycled water system.
8	Keep reclaimed/recycled water system pressurized for the minimum time specified by the code official, which will be no less than one hour, while the potable water system is empty. ^a
9	Test and inspect all potable and recycle/reclaimed fixtures for flow. –flow from any potable water system outlet indicates a cross connection –no flow from a reclaimed/recycled water outlet may indicate a cross connection.
10	Check for flow at the drain of the potable water system during and at the end of the test.
11	Test and inspect all potable and recycle/reclaimed fixtures for flow. –flow from any reclaimed/recycled water system outlet indicates a cross connection –no flow from a potable water outlet may indicate a cross connection.
12	If there is no indication of a cross connection, repressurize the potable water system.

^a Minimum period is determined on a case-by-case basis according to the size and complexity of the system.

Table G.3 Procedure for cross-connection test (steps to be followed by the owner's agent in presence of the San Antonio code official and other authorities having jurisdiction) [SAPCS1304.5.2]

1	Shut down reclaimed/recycled water piping to the building at the meter.
2	Drain the reclaimed/recycled water riser.
3	Shut down the potable water piping to the building at the meter.
4	Uncover and disconnect the cross connection.
5	Retest the building per procedure outlined in Table G.2.
6	Chlorinate the potable water system with 50 ppm chlorine for 24 hours.
7	After 24 hours of chlorination, flush the potable water system.
8	Perform a standard bacteriological test on the potable system.
9	If test results are acceptable, the potable water system may be recharged.

Appendix H: Projected SAWS General Class (Commercial) Water and Sewer Rates

	Year	Water Supply Availability Fee for a 3" meter(\$) ^a	Water Volume Charge ^b (\$ per 100 gallons)				Water Supply Fee (\$ per 100 gallons)	Edwards Aquifer Authority (EAA) Fee (\$ per 100 gallons)	Sewer Minimum Fee for 1,496 gal per month (\$)	Sewer Charge (\$ per 100 gallons)	Texas Commission on Environmental Quality (TCEQ) Fee (\$)	Total Fee per additional gallon ^c	Percent Increase in Fee per additional gallon	
			≤ base	100-125% base	125-175% base	>175% base								
Actual ^d	2010	106.92	.1086	.1257	.1801 ^e	.291915	.1529	.01841	7.76	.2057	.24	.5027	0	
	2011	124.80	.1110	.1327	.1861	.2725	.1573	.01407	8.68	.2302	.26	.5343	6.3	
	2012	129.04	.1148	.1372	.1924	.2818	.1620	.01719	9.86	.2615	.23	.5779	8.2	
Projected	2013											.6241	8.0	
	2014											.6741	8.0	
	2015											.7280	8.0	
	2016		Where FPG = previous year's total fee per additional gallon x										.7862	8.0
	2017		(1.08) to obtain an 8% increase per year ^f										.8491	8.0
	2018												.9170	8.0
	2019												FPG	8.0

^a The water supply availability fee is a flat fee is determined by the size of the potable water supply line.

^b Since commercial buildings' water consumption fluctuates monthly and commonly ranges from below the base value up to 150% of the base value, the water volume charge for 100-125% base flow is used as an estimate of the average water volume charge per month for computations in this table.

^c Fee per additional gallon does not include the following flat rate fees: water supply availability, sewer minimum, or TCEQ fees, which are assumed to be paid with or without reclaimed water system in place. If any of these fees are reduced or eliminated by use of on-site reclaimed water then these values should be included in cost savings calculations

^d Fees published by San Antonio Water Systems (SAWS).

^e Values were averaged to account for volume thresholds prior to 2011 being different from those on table.

^f The 8% increase in water fees per year is based on McDonald (2011) and McDonald (2013). This calculation can be repeated indefinitely, depending on expected year required for payback.

References

McDonald, Colin. 2011. "SAWS Bills May Rise 14.7%." *San Antonio Express News*, 14 September.

McDonald, Colin. 2013. "Water Rate Increase Necessary." *San Antonio Express News*, 16 January.

SAWS. "General Class Water Service and Sewer Rate." < www.saws.org/service/rates/general.cfm > Accessed 20 November 2012.



P.O. Box 2449 • 2800 U. S. Hwy. 281 North • San Antonio, TX 78298-2449
210.704.7297 • www.saws.org