

Trinity University Digital Commons @ Trinity

Mechatronics Final Projects

Engineering Science Department

5-2018

Articulated Robot Hand

Nick Lo Bue

Trinity University, nlobue@trinity.edu

Tanner Peterson

Trinity University, tpeterso@trinity.edu

Sam Steup

Trinity University, ssteup@trinity.edu

Andres Suarez-Domit

Trinity University, asuarezd@trinity.edu

Follow this and additional works at: https://digitalcommons.trinity.edu/engine_mechatronics



Part of the [Engineering Commons](#)

Repository Citation

Lo Bue, Nick; Peterson, Tanner; Steup, Sam; and Suarez-Domit, Andres, "Articulated Robot Hand" (2018). *Mechatronics Final Projects*. 8.

https://digitalcommons.trinity.edu/engine_mechatronics/8

This Report is brought to you for free and open access by the Engineering Science Department at Digital Commons @ Trinity. It has been accepted for inclusion in Mechatronics Final Projects by an authorized administrator of Digital Commons @ Trinity. For more information, please contact jcostanz@trinity.edu.

Mechatronics Design Project

Articulated Robot Hand

Group A

Nick Lo Bue

Tanner Peterson

Sam Steup

Andres Suarez-Domit

Submitted: 3 May 2018

Table of Contents

Title Page	1
Table of Contents	2
Design Summary	3
System Details	3-4
Partial Parts List	4
Lessons Learned	4-5
Appendix	6-10

Design Summary

The purpose of this project is to create a robotic hand that articulates and grips objects like a human hand. The robotic hand includes a single miniature servo for each finger joint, as shown in Figures 2 through 4, allowing full and independent articulation of the nine different primary joints in the hand. The motion of each servo, and therefore each finger joint, is governed by a PIC microcontroller. Use of a microcontroller-based control scheme, as opposed to PC-based control, allows for a more portable, versatile design.

A buzzer-based warning system notifies the user of any major irregularities in the operation of the robotic hand. The force exerted by the hand on an object being gripped, will be monitored by touch sensors mounted to the end joints of each digit. A small LCD will display information relating to the operational mode of the hand, as well as any relevant user warnings. A set of potentiometers allow the user to manually control the rotational position and reaction speed of each joint. A 4x4 keypad enables the user to navigate an operational menu displayed on the LCD, and to select a preset position in the automatic operating mode.

System Details

The electrical system can be broken into three subsystems, these being controls, actuators, and displays and audio output. The purpose of each subsystem is to break up the work into manageable pieces that can be worked in parallel. The controls subsystem consist of two circuits, one uses a keypad, the other uses a potentiometer. Each of these circuits is a form of manual control, that the user selects from a menu incorporated into the keypad. The circuit for the keypad is shown in Figure A.3, and works by supplying power from the pic to each column then scanning for a low signal in each row until either all rows have been scanned or a button press is detected. The actuators are a set of servos that control each digit, an example of these circuits is shown in Figure A.4. These are simple circuits that depend on circuits internal to the servo and control signals from the pic to move. The third and final subsystem of the electrical design makes up the output portions of the project. In the initial design the visual display was an LCD, but LEDs can be substituted to simplify the design and conserve pins. The circuit for the use of the LDC is shown in Figure A.5, and uses the LCD in the 4-pin configuration which sends control signals from the pic to the LCD in the form of nibbles. The audio output consists of a single speaker that produces a single tone from a simple control circuit.

Design Evaluation

The group however managed to get two major parts of the design working, the physical fingers of the hand and the use of a hexpad to set a servo to predetermined positions. These two parts of the design worked as intended meaning that three of the functional element categories were fulfilled. By pressing different buttons on the hexpad the servo was set to a range of preset positions, this meant that both the manual user input as well as the actuators of the system worked as intended. The programming for the aforementioned hexpad worked as intended, the code used properly ran the hexpad using open-loop control where it generated output pulses to the servo independently of what outputs were given previously.

Partial Parts List

Component	Vendor	URL	Quantity	Unit Price
HK-282a Micro Servo	Hobby King	https://hobbyking.com/en_us/hk-282a-single-screw-ultra-micro-servo-2g-0-2kg-0-08sec.html	12	\$3.77
Force-sensing resistor	Trossen Robotics	http://www.trossenrobotics.com/store/p/6492-2-Inch-Force-Sensing-Resistor-FSR.aspx	3	\$5.95
PIC 18F2550	Trinity Shop	https://www.digikey.com/product-detail/en/microchip-technology/PIC18F2550-I-SO/PIC18F2550-I-SO-ND/704574	1	\$4.25
PIC 16F88	Trinity Shop	https://www.digikey.com/product-detail/en/microchip-technology/PIC16F88-I-P/PIC16F88-I-P-ND/529780	2	\$2.68
1602A LCD	Trinity Shop	https://www.thingbits.net/products/standard-lcd-16x2-display	1	\$3.99
1536 Buzzer 5V	Trinity Shop	https://www.adafruit.com/product/1536	1	\$0.95
4x4 Matrix output keypad	Trinity Shop	https://www.digikey.com/product-detail/en/grayhill-inc/96BB2-006-FS/96BB2-006-FS-ND/2680483	1	\$17.00

Lessons Learned

Keeping track of important due dates is essential to appropriate prioritization of work on the project. The design notebook aspect of the assignment, while it can seem like an unnecessary formality, is a useful tool to keep track of the work that has been done, and the decisions that have been made. Our group had much of the work front-loaded on some of our members, leaving the other members out the project for a fair amount of time. Because of this the efficiency of the

work done was essentially halved. Just because a demo is not due does not mean your group shouldn't try to get something working. Communication among group members is essential to maintain steady progress on the project and ensure that everyone has responsibilities.

From a technical standpoint, running an LCD on a PIC which is also controlling other components can prove to be problematic. It is generally simpler to configure an additional PIC as a slave, and have it independently running the LCD. For running servos, the PWM command is insufficient to adequately send the correct command signal. It is far more effective to simply write a high, wait, and then right a low using the PAUSEUS command. For any 3-D printed components to a project design, it is best to model and print them as soon as possible, so that any problems with fit, weight, or materials can be addressed early and assembly can begin sooner. Finally, it is virtually impossible to understate the usefulness of the bottom-up method of system assembly and testing. Troubleshooting is nigh impossible with the entire system wired and communicating, but each individual piece can be simply and easily debugged to ensure proper operation.

Appendix

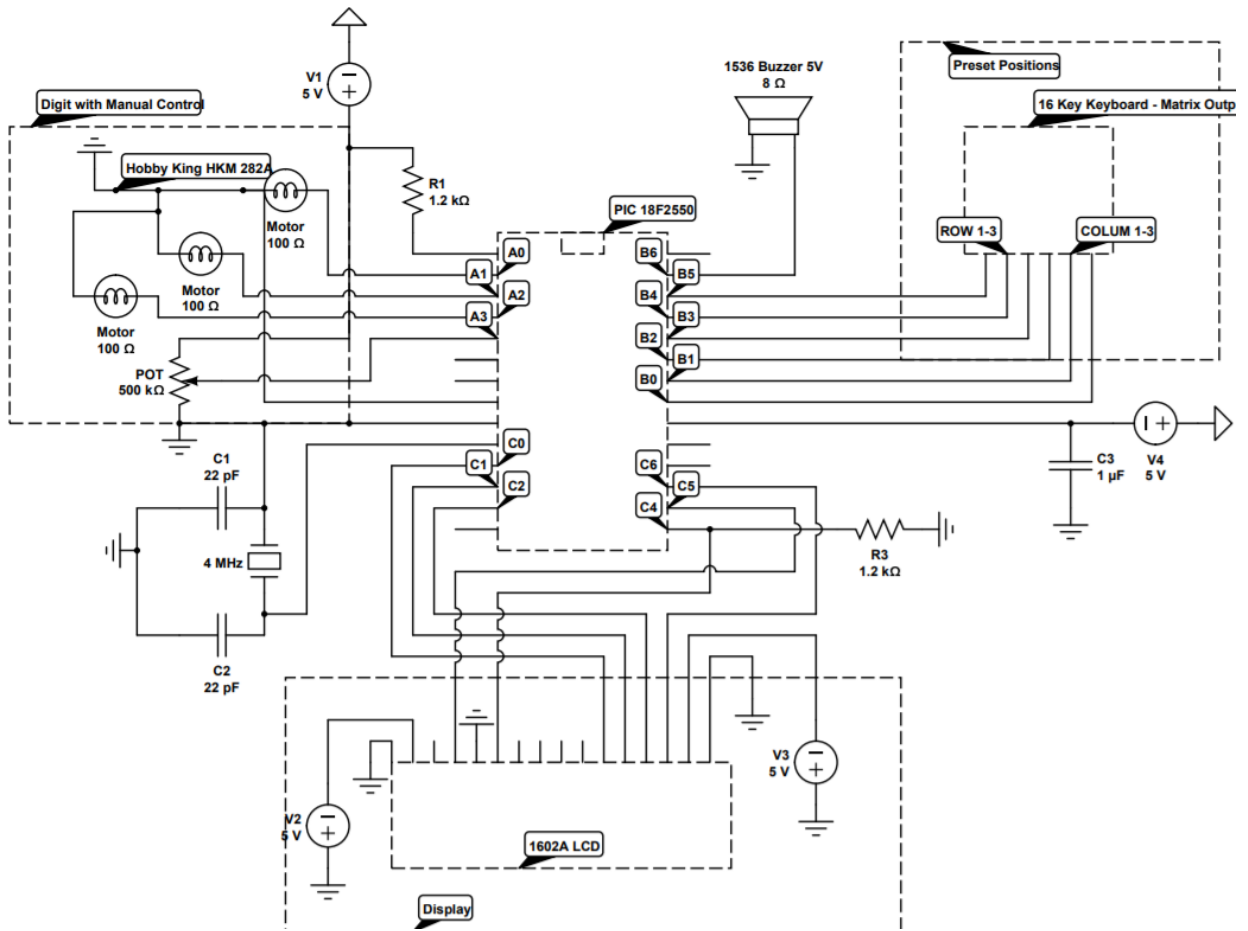

Figure A1. Circuit diagram for primary PIC, with external oscillator, used to control robotic hand system

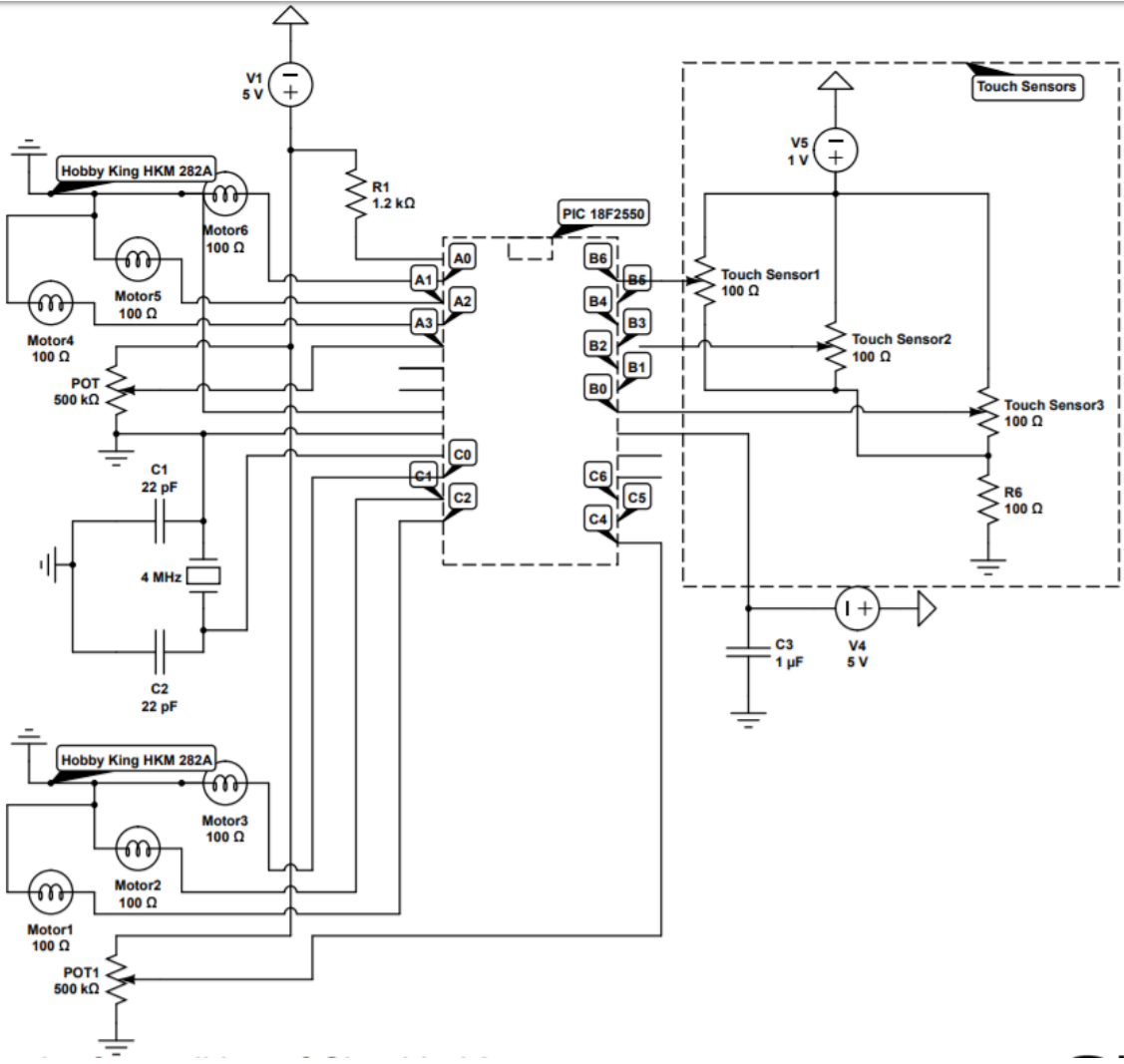

Figure A2. Circuit diagram for secondary PIC, with external oscillator, used to control robotic hand system

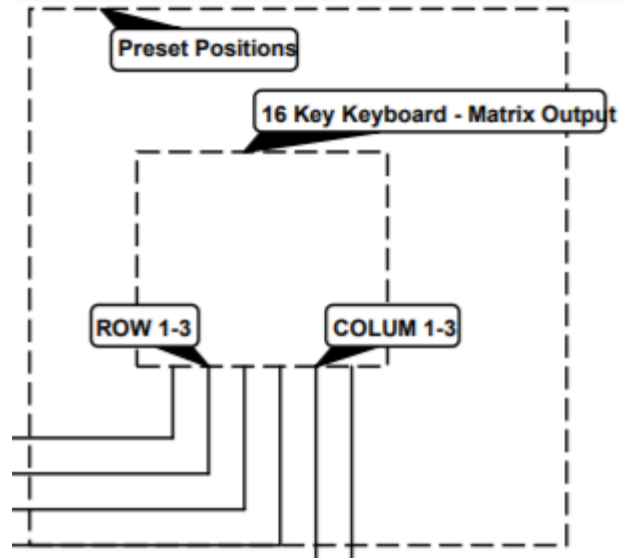

Figure A3. Circuit diagram for keypad used for menu control of system and servo position presets.

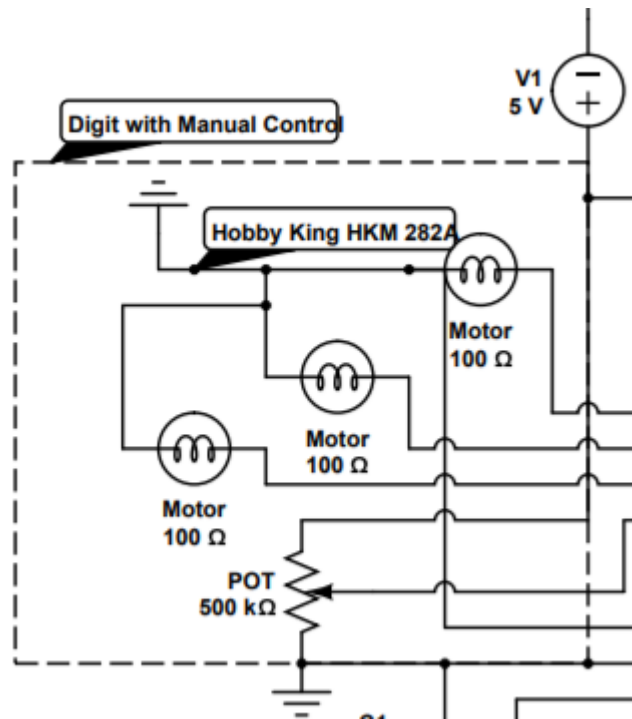

Figure A4. Circuit diagram for digits showing the data line used to control servos and the potentiometer as a form of manual input.

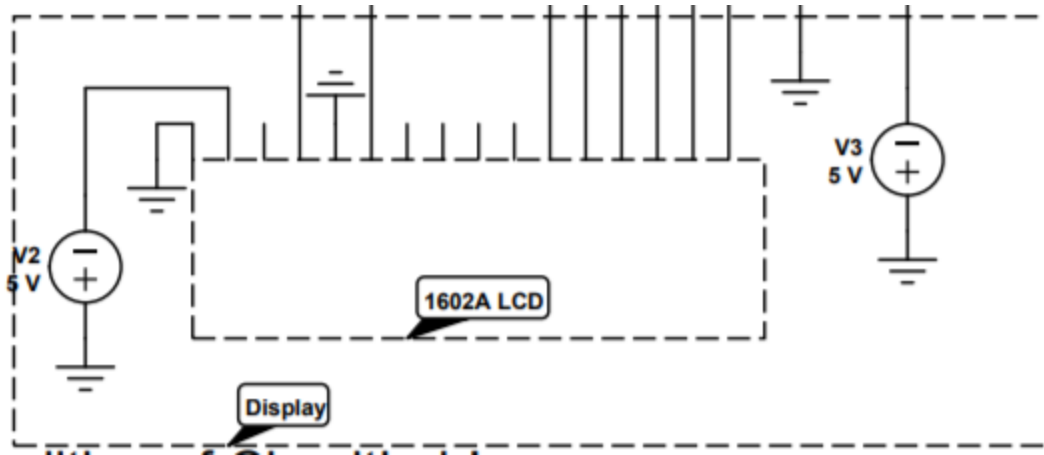
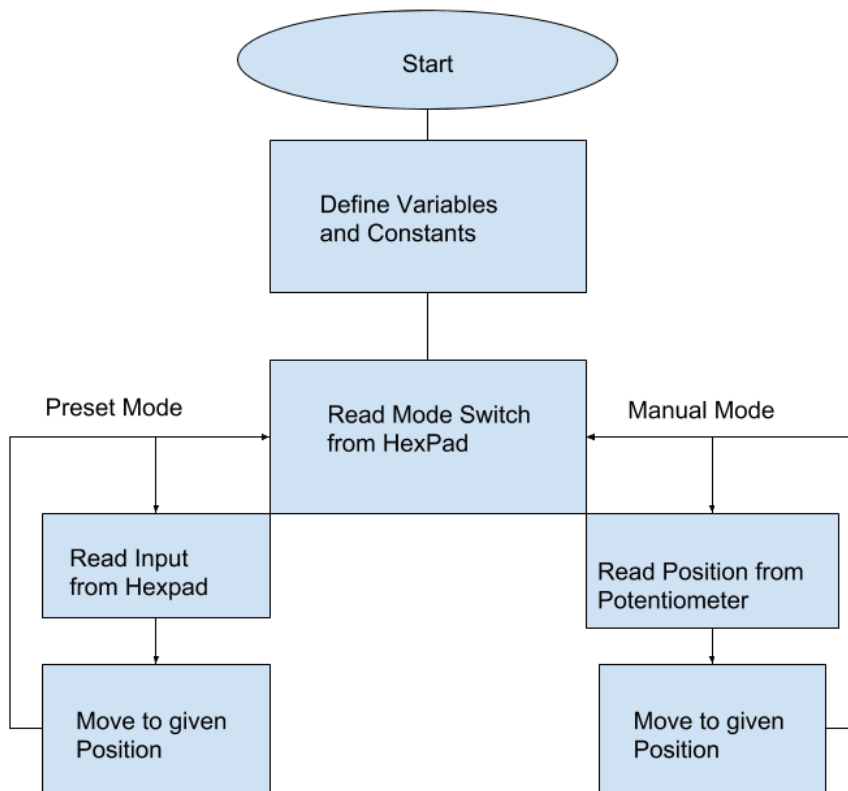
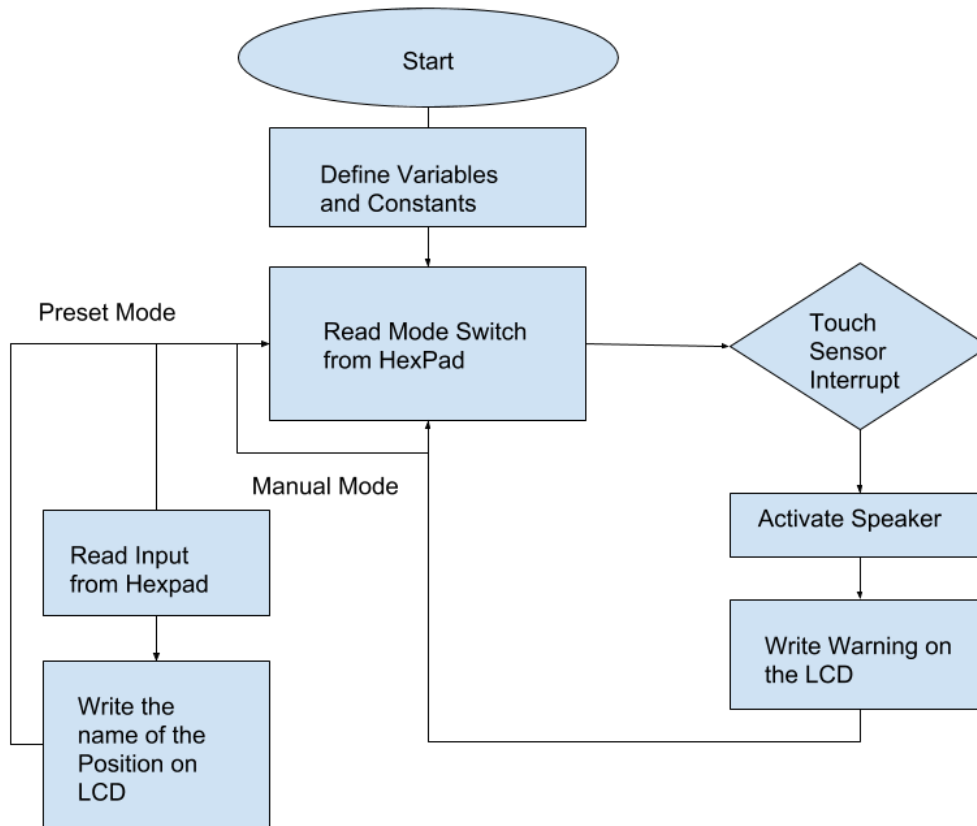

Figure A5. Circuit diagram LCD, initially to be used as visual display element, but



replaced with LED in the final design.

Figure A6. Flow chart for operation of individual digits of robotic hand



Option 1: Articulated Hand

Output Display

- Control display screen showing menu, settings, options, etc.

Audio Output Device

- Warning buzzer when meeting or exceeding safe positioning range
- Welcome sound on "Power On"

Manual User Input

- Manual hand positioning controlled by potentiometers/sliders
- Gesture/operating mode selection screen or keypad

Automatic Sensor

- Detection for if motors are running and hand joints aren't moving
- Pressure sensors for tuning grip strength

Actuators, Mechanisms & Hardware

- Reversible, miniaturized motors for each joint, or motors for each digit with tensioning lines
- 3-D printed base and "bones" for each digit

Logic, Processing, and Control; AND Miscellaneous (functional elements not covered in the categories above)

- Menu-driven software for different operating modes (manual, pre-programmed)
- Open-loop control with safety cut-offs to avoid over-articulation

Figure A7. Flowchart for operation of LCD operation in robotic hand system

Figure A8. Original brainstorming for structure and operation of project, included for reference