

ULTRA-SHORT PULSES OF HEAVY IONS

by

L. M. Bollinger, T. K. Khoe, F. J. Lynch, B. Zeidman,  
R. Benaroya, J. J. Bicek, Jr., B. E. Clifft, A. H. Jaffey,  
K. W. Johnson, J. M. Nixon, W. A. Wesolowski

For Presentation At:

1975 Particle Accelerator Conference,  
Washington, D. C., March 12-14, 1975

**MASTER**

DISTRIBUTION OF THIS DOCUMENT IS UNLIMITED



U of C-AUA-USAEC

**ARGONNE NATIONAL LABORATORY, ARGONNE, ILLINOIS**

L. M. Bollinger, T. K. Khoe, F. J. Lynch, B. Zeidman, R. Benaroya, J. J. Bicek, Jr.,  
B. E. Clift, A. H. Jaffey, K. W. Johnson, J. M. Nixon, W. A. Wesolowski

Argonne National Laboratory, Argonne, Illinois 60439 U.S.A.

### SUMMARY

The bunching requirements for a heavy-ion tandem-linac accelerator are defined and a bunching system to satisfy these requirements is outlined. This discussion introduces an experiment on the bunching of 45 MeV  $^{16}\text{O}$  ions by means of a  $\lambda/2$  superconducting-helix resonator. The measured ion-bunch width is 64 psec, a value dominated by the resolution width of the ion detector. By correcting for the detector-resolution width one infers that the ion bunch itself is <40 psec wide.

### I. INTRODUCTION

Until recently, most of the emphasis in the design and operation of ion linacs has been on achieving the required energy range with the maximum of beam current, and relatively little attention has been paid to the quality of the output beam. However, during the past few years a need has developed for heavy-ion accelerators with extremely good beam quality, and several concepts aimed at satisfying this need have been studied. One of these is the tandem-linac system, in which a tandem electrostatic accelerator injects into the linac, thus providing the linac with an incident beam that has both good energy resolution and emittance. In view of these good qualities, if the tandem beam can also be formed into pulses that are narrow enough, then one has the possibility of having the linac operate in essentially a linear mode and in this way preserve the quality of the incident beam.

The main idea behind linear operation of the linac is shown in Fig. 1, where the deviation  $\Delta E$  of the projectile energy from the synchronous energy is plotted as a function of phase angle  $\phi$ . If the energy and phase-angle scales are chosen correctly, the trajectories for particles in the neighborhood of the synchronous point are circles, as shown in Fig. 1. Moreover, in this region the rate of rotation is almost the same for all circles. Thus, the acceleration process rotates the phase ellipse of the incident beam, but the shape and the area of the ellipses are preserved. That is, the longitudinal emittance  $\Delta E \Delta t$  is preserved, where  $\Delta E$  and  $\Delta t$  are mean values of the energy and time spreads, respectively, at positions where the phase ellipse is symmetrical with respect to the axes.

In addition to the influence of a non-linear accelerating force, various other effects can deteriorate

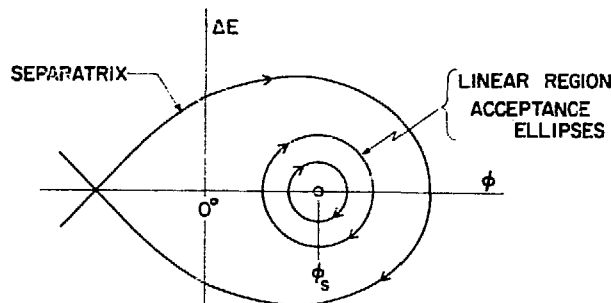

Fig. 1. Trajectories in phase space of particles in a linac with synchronous phase  $\phi_s$ .

the beam quality, and these effects are minimized if the phase ellipse of the incident beam is matched to an acceptance ellipse of the linac — i.e., matched to one of the circles in Fig. 1. Thus, for optimum performance of the linac (in the sense of minimizing  $\Delta E \Delta t$ ), the phase ellipse of the injected beam should have a specific ratio  $\Delta E / \Delta t$ , and hence for any given value of  $\Delta E \Delta t$ , it should have a specific pulse width  $\Delta t$ .

A general discussion of the relationship between the time spread of the incident beam and the energy spread of the output beam is beyond the scope of this paper<sup>1</sup>. However, a typical example will indicate the magnitude of the beam-bunching problem. Consider a small linac that accelerates  $^{58}\text{Ni}$  ions from an incident energy of 1.7 MeV per nucleon to 6.3 MeV per nucleon. Let the RF frequency be 90 MHz, the accelerating field 3 MV/m, the phase angle  $80^\circ$ , and the ion charge 20. Then in order to obtain an energy resolution  $\Delta E/E$  of  $\sim 10^{-3}$  with a matched beam, the time spread of the input bunches must be about 49 psec. (FWHM). The corresponding energy spread of the incident beam is 226 keV.

The need for an input-pulse width <100 psec and a correspondingly small energy spread is not the only demanding requirement on the bunching system for a tandem-linac accelerator. The other requirement is to be able to bunch a large fraction of the DC beam into the desired narrow pulses. Under many circumstances, there is little beam current to be wasted because of limitations of negative-heavy-ion sources and because of the inability of the tandem itself to accelerate large currents of heavy ions.

As a consequence of considerations such as outlined above, we accept the following design objectives for the bunching system of a planned tandem-linac accelerator operating at an RF frequency of about 90 MHz: 80% of the DC beam should be bunched into pulses <100 psec wide. This paper outlines the general characteristics of the proposed system and then presents results of an experiment in which ultra-short heavy-ion pulses have been measured.

The magnitude of the challenge of the design objective stated above may best be appreciated by comparing it with the performance of working heavy-ion bunching systems. Few such systems are in operation yet. For these, the typical performance is that <10% of the DC beam is bunched into pulses  $\sim 1$  nsec wide. Thus, the high-resolution operation of a tandem-linac accelerator requires an order-of-magnitude improvement both in beam utilization and in pulse width.

### II. PROPOSED BUNCHING SYSTEM

Fig. 2 outlines the system being proposed to bunch 85% of the DC beam into pulses <100 psec wide at 90 MHz. The bunching process takes place in three main stages: (1) the pre-tandem bunchers compress 85% of the beam into pulses that are <1 nsec wide at the tandem terminal, (2) the post-tandem buncher compresses the 1-nsec pulse down to a width <<100 psec at the second stripper, and (3) the debuncher matches the phase ellipse of the beam to the requirements of the linac. A debunching system after the linac is also desirable, but this is not discussed in this paper.

MASTER

pen

Fig. 2. Schematic of an advanced bunching system for a tandem-linac accelerator. Radial-focusing elements are not shown.

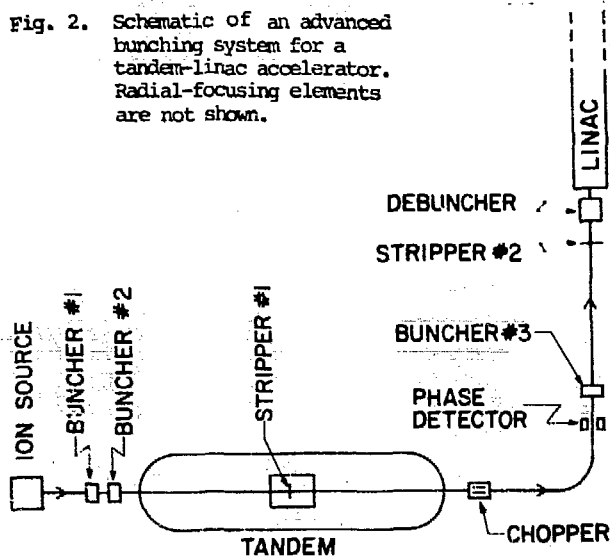

The proposed pre-tandem buncher system consists of two accelerating structures, buncher #1 (Fig. 2), operating at the fundamental RF frequency and buncher #2 at the second harmonic. The performance of the system is improved by using a 1/3 ratio for the spacing between the bunchers and the spacing between buncher #2 and the position of the time focus, as proposed by Goldstein and Laisne<sup>2</sup>. Since the heavy ions are moving slowly and the bunching path lengths may be several meters, bunching is achieved with energy variations of only a few hundred eV. Extensive calculations show that, in spite of several time-spreading effects, it should be feasible with a harmonic bunching system to compress >85% of the DC beam from the source into pulses <1 nsec wide at the terminal. However, to do so it will probably be necessary to use fine grids on the gaps of the bunching structures, which may be a considerable source of practical difficulty.

A beam chopper after the tandem eliminates unbunched ions.

The sequence of bunching events in the post-tandem region are illustrated in Fig. 3. The ion bunch leaves the tandem terminal with a fairly wide spread in time ( $\pm 0.5$  nsec) and a narrow spread in energy. The time spread is determined by the characteristics of the pre-tandem buncher and the energy spread by the energy straggling in the stripper. The phase ellipse shears forward somewhat before reaching buncher #3, which, in a highly-linear operation, tilts the phase ellipse as shown. As the bunch travels toward the linac, the phase ellipse skews forward and is upright (a time focus) when it arrives at the second stripper. Because of the large energy spread induced by buncher #3, energy straggling in the stripper foil introduces relatively little additional energy spread.

Because of the need for a time focus at (or near) the second stripper and because the bunching path length is fixed, a single bunching structure cannot, in general, match the beam to the linac. This operation required the addition of a second accelerating structure, the debuncher, which in Fig. 3 produces a phase ellipse that is symmetrical with respect to the  $\Delta E, \Delta t$  axes. With two accelerating structures (the buncher and debuncher), both the shape of the phase ellipse of the bunch and its orientation can be varied if one does not require that the position of the time focus be exactly at the stripper. This compromise does not have a significant influence on the longitudinal

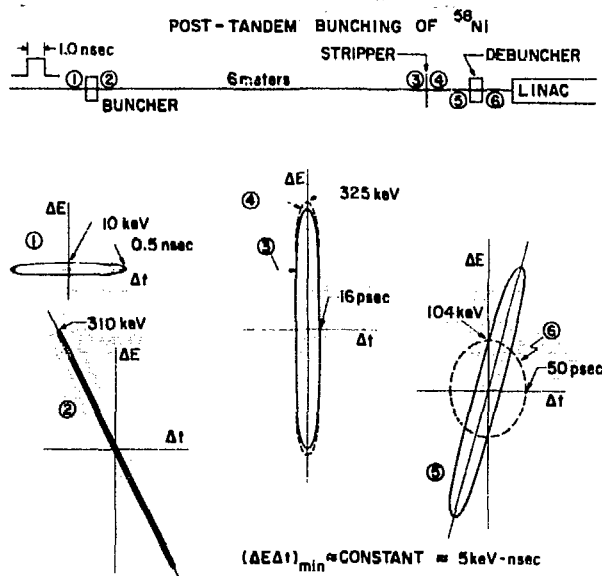

Fig. 3. Bunching process in the post-tandem region for  $^{58}\text{Ni}$  ions and a foil stripper in a tandem with a 10-MV terminal.

emittance for a wide range of circumstances.

Two questions are frequently asked about the operation outlined by Fig. 3: (1) is it practical to build the required bunching structures; and (2) are there time-spreading effects that are so large that the idealized treatment is meaningless? The first question is readily answered. A  $\lambda/2$  superconducting element such as the helix resonators tested extensively<sup>3,4</sup> in this Laboratory are more than adequate for the bunching function. The debuncher needs to be a somewhat larger structure, perhaps a  $3\lambda/2$  helix, and hence it is fairly expensive. Fortunately, a separate debunching structure may not be necessary, since one can show that the first accelerating structure of the linac itself can perform the function of debunching (or beam matching) without giving up much of its accelerating power.

The question concerning the magnitude of time-spreading effects is more difficult. Detailed calculations have been made on the influence of the following effects: space charge, beam divergence, resonator non-linearity, radial variation of bunching field. The overall time spread introduced by these effects is typically <5 psec if the average beam intensity is  $<6 \times 10^{12}$  particles/sec, a large beam current for heavy ions. Thus, the time spreading effects should be negligible in most applications. However, because the bunch widths being considered are so very much shorter than have been observed heretofore, many seem to find such calculations unconvincing. The main point of this paper is to present the results of an experimental demonstration that ultra-short pulses of heavy ions can be produced.

A possible time-spreading effect that is not listed above is the variation in the accelerating voltages in the tandem, which could cause a variation in the time of arrival of the bunch at buncher #3. Variations in the terminal voltage or in the voltage distribution along the accelerator tube could be important in this respect. These effects are not included with the others because they are expected to occur on a time scale that is slow enough to permit correction. Presumably, the voltage of the tandem terminal can be made as stable as is necessary. Control of the influence of changes in the

voltage distribution is a less conventional problem. We propose to eliminate the effect of such variations by sensing the phase error (relative to a master oscillator) of beam pulses arriving at buncher #3 and by using this phase error to control the phase of the pre-tandem bunchers.

### III. THE BUNCHING EXPERIMENT

As a part of a more general effort to develop heavy-ion bunching techniques, we have carried out an experiment aimed at demonstrating that unforeseen effects do not prevent the formation of ultra-short pulses of heavy ions. The experimental system used is illustrated in Fig. 4. Ions of  $^{16}\text{O}$  with charge 5+ were accelerated to 45 MeV by an FN tandem. This beam first passes through a conventional beam chopper consisting of RF deflection plates that sweep the beam over a slit about 3 meters downstream. All ions in the relatively wide bunch so formed are then compresses (as in Fig. 3) by a  $\lambda/2$  helix resonator, (unit G<sub>2</sub> of Ref. 3) which operates at 91.6 MHz. The helix accelerating field is adjusted to make the phase ellipse come to a time focus at a detector 8.3 meters downstream. The detector is a commercial surface-barrier detector that responds to individual  $^{16}\text{O}$  ions that are elastically scattered at a small forward angle ( $13^\circ$ ) by a thin gold foil ( $\sim 75 \mu\text{g}/\text{cm}^2$  thick). The difference in time between the detected ion and a zero-time pulse derived from the RF wave of the helix is then converted into a pulse height, and this pulse height, a linear function of the ion-flight time, is recorded in a pulse-height analyzer. This gives a direct measure of the beam-pulse shape except for the influence of the detector resolution function.

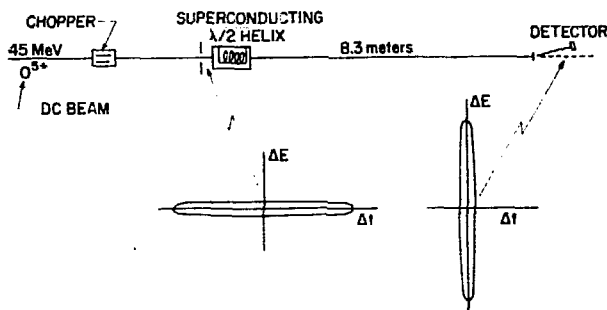

Fig. 4. Schematic of the bunching experiment.

Since the helix performs a linear operation on the incident ion bunch, the area of the phase ellipse is preserved during the bunching process unless there are unforeseen time-spreading effects. Consequently, a lower limit on the bunch width  $\Delta t_b$  at the position of the time focus is  $\Delta t_b = \Delta E_a \Delta E_a / \Delta E_b$ , where the subscript *a* refers to the position just before the helix and *b* refers to the time-focus position. Note that  $\Delta E_b$  is mainly determined by the energy variation required to bunch the beam in the flight path involved.

Estimates of the various contributions to the bunch width are summarized in Table I. The overall width is expected to be  $\sim 20$  psec, much narrower than can be measured with any heavy-ion detector. Thus one expects to measure only an upper limit of the bunch width.

The various factors that contribute to the time-resolution width of the detector system are also summarized in Table I. The dominant contribution comes from the detector itself, but the effect of the target is not zero. It is of interest to note that the flight-path difference introduced by scattering the ions at  $13^\circ$  is  $\sim 0.17$  mm, and this corresponds to a time spread

of  $\sim 8$  psec. This observation emphasizes the fact that the expected beam-pulse width of 20 psec corresponds to a path difference of only 0.4 mm!

Table I. Sources of time uncertainty in the bunching experiment.

Beam-Bunch Effects	Estimate FWHM Time Spread
ion-energy straggling (1 keV)	4 psec
ion-energy oscillation (4 keV)	18
ion-energy drift (2 keV)	8
beam divergence	<1
space charge	<1
other effects	<1
overall bunch width	20 psec
<b>Detector-System Effects</b>	
$\Delta$ flight path at target	8 psec
target energy straggling	$\sim 2$
detector resolution	$\sim 50$
phase jitter, zero-time pulse	<15
overall resolution width	$\leq 54$ psec

Two kinds of bunching measurements were carried out. In one, the phase range of ions incident on the buncher was selected by the chopper, which was operated at a voltage that gave a beam-pulse width  $\Delta t_a = 670$  psec (FWHM), i.e.,  $\Delta \phi_a = 22^\circ$ .

In the second kind of measurement, the initial phase range was defined by restricting the ion-energy range accepted by the detector. The idea here is illustrated in Fig. 5, which gives ion energy as a function of time of arrival at the position of the time focus, assuming that the incident energy  $E_a$  is a constant. One sees that the requirement  $\Delta E / \Delta E_{\text{max}} \ll 1$  restricts the ions accepted for measurement to those that arrive at the helix in the neighborhood of  $\phi = \pm 90^\circ$ . Those near  $-90^\circ$  form a broad peak and those near  $+90^\circ$  are the bunched ions of interest. The only limitation to this procedure is that the relatively poor energy resolution of the detector tends to smear out the phase range selected. The extent of this problem may be judged from the following data:  $\Delta E_{\text{max}} = 450$  keV; detector resolution width = 140 keV.

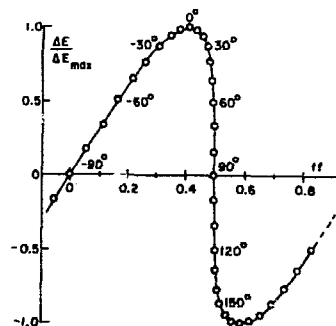

Fig. 5. Plot of the variation  $\Delta E$  of beam energy with respect to time *t* of arrival at the detector when the chopper is not used. The numbers associated with the points give the incident phase angle  $\phi_a$ . The buncher amplitude is adjusted to give a time focus at the detector meaning that  $dE/dt$  is infinite at  $\phi_a = 90^\circ$ .

Unfortunately, the ion detector performed rather poorly during our bunching measurements and, since only about 12 hours of beam time was available, the problem could not be eliminated. Specifically, when the detector was operated at the bias voltage recommended by

the manufacturer, the measured time distribution consisted of two distinct peaks. Examples are shown in Fig. 6. One sees that the time distribution is essentially the same for the two ways of selecting the initial phase. This similarity tends to confirm the equivalence of the two methods used to select the phase range accepted by the system since, as indicated below, all our data indicate that the detector pulses fall into two classes (which form different peaks) that are not related to the time of arrival of the ions. If so, the relatively narrow peak on the left, which is the same for the two modes of phase selection, gives an upper limit for the width of the beam pulse.

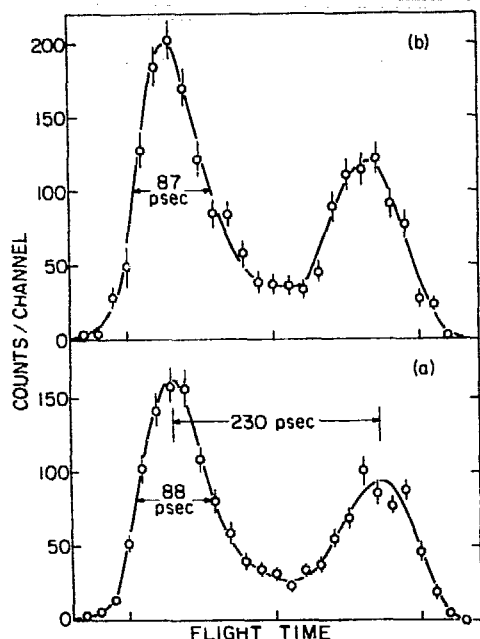

Fig. 6. Measured time spectrum of the bunched  $^{160}$  beam when the detector bias voltage was low (70 V). Curve (a) gives the results obtained when the incident-phase range was selected by limiting the final energy to values near the incident energy. Curve (b) was obtained when the chopper selected the incident-phase range.

It was found that the two peaks in the time spectrum could be brought together by increasing the bias voltage well above the recommended value. This procedure also decreased the widths of the individual peaks. At the voltage just before the two peaks merge, the width of the one on the left was  $\sim 55$  psec.

The time spectrum measured when the detector bias was increased to 250V, about 4.5 times the recommended value, is given in Fig. 7. Here the two peaks have merged and the overall width of the distribution is 64 psec. Unfortunately, the highest bias voltage was used only with the energy-restriction technique of phase selection because the detector was destroyed by the extreme operating conditions before the measurement with the chopper could be made. Nevertheless, in view of the data and interpretation given above, our bunching experiment shows conclusively that the beam-bunch width is  $< 64$  psec. Moreover, if the resolution width of the detector system is  $\geq 50$  psec, as is almost certain, then one infers that the beam bunch is  $< 40$  psec wide. This result removes most of the doubts about the possibility of forming ultra-short pulses of heavy ions.

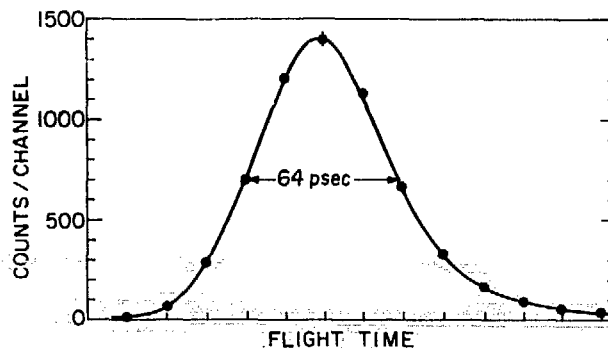

Fig. 7. Measured time spectrum of the bunched  $^{160}$  beam for the maximum detector-bias voltage (250 V). The incident-phase range was selected by limiting the final energy to values near the incident energy.

One of the most encouraging aspects of our measurement was the ease with which the superconducting-helix structure could be used. At the time of our measurement, the resonator had been on the beam line for about 4 weeks and had been operated at power about 3 weeks earlier. On both occasions, the maximum accelerating field for stable operation was about 2.9 MV/m at an RF-power input of about 1.7 watts. This corresponds to a maximum energy gain of  $\pm 365$  keV for protons or  $\pm 1.8$  MeV for  $O^{5+}$ . The system was maintained at liquid-nitrogen temperature between the two tests, and the cooldown to liquid-helium temperature for the second test proceeded in a completely routine way.

The accelerating field required in our bunching experiment was only 0.757 MV/m. At this field, the RF-power input was about 0.065 watts, so that the liquid-helium loss was dominated by heat loss in the cryostat.

In the bunching experiment, the chopper was locked to the helix resonator, which was operated in a self-excited mode. No effort was made to control the resonator frequency of the helix, although it would have been easy to do so with improved versions of the VCX technique described previously<sup>5</sup>. Both the RF system and the cryogenic-control system operated with complete ease and reliability over a period of  $\sim 24$  hours on two occasions, indicating that a superconducting  $\lambda/2$  helix bunching system is now suitable for routine use in experiment.

#### IV. IMPLICATIONS OF THE BUNCHING EXPERIMENT

The experiment outlined above indicates that the formation of ultra-short pulses of heavy ions at the energies provided by a tandem is a straightforward matter, with no significant barriers in principle. The main problems are simply those of implementing the ideas outlined in Sect. II. Thus, one can proceed with confidence to develop the concept of a tandem-linac accelerator system that operates with good energy resolution by injecting it with very short beam pulses.

Almost as important, the availability of ultra-short bunches of heavy ions opens up many exciting new experimental possibilities, and the ease with which our bunching experiment was carried out is leading us to proceed immediately to develop a complete bunching system for this purpose. This system is aimed at the needs of nuclear heavy-ion physics, for which one wants to bunch most of the DC beam from the ion source into bunches  $\leq 50$  psec wide at frequencies 30-50 MHz. We intend to proceed in the way outlined in Fig. 2 except

that, for simplicity, the energy spread of the bunch beam will be limited by using the longest available flight path (about 13 meters) rather than by a de-buncher.

An important physics objective of the proposed bunching system is to be able to measure the velocity of heavy products produced in heavy-ion-induced nuclear reactions. The velocity, when combined with the particle energy and the rate of energy loss  $\Delta E/\Delta x$ , allows one to determine cleanly the mass and the nuclear charge  $Z$  of an ion, as has already been beautifully demonstrated<sup>6</sup> by means of a time-of-flight telescope in which one measures the time difference between an ion passing through a thin  $\Delta E$  surface-barrier detector and stopping in a thick detector only 23 cm away. In the simplest application of very short beam pulses, one would make similar measurements, but with the zero time being given by the known arrival time of the bunch on the target. This approach would remove various problems caused by scattering of ions in the  $\Delta E$  detector. In particular, the pulsed beam is essential for very heavy low-energy reaction products, which cannot get through the  $\Delta E$  detector.

In more general terms, the availability of beams of heavy ions with ultra-short pulse widths, good energy resolution, and good emittance would enable the experimenter to make use of spacial localization of the bunch in a powerful way. In particular, one can visualize many new experimental possibilities for untangling the complexities of heavy-ion reactions that result in fission or in fusion of the projectile and target nuclei.

From the viewpoint of accelerator development, the immediate application of superconducting accelerating structures to the needs of heavy-ion physics is attractive because it will undoubtedly provide many insights into the practical problems of the new technology.

#### References

\*Work supported by the U.S. Energy Research and Development Administration.

1. The theoretical basis for this paper will be published by T. K. Khoo et al.
2. C. Goldstein and A. Laisne, Nucl. Instr. Methods 61, 221 (1968).
3. J. Aron et al., Proc. IXth Intern. Conf. High Energy Acceleration (CONF 740522) p. 159 (1974).
4. R. Benaroya et al., Proc. of the 1974 Applied Superconductivity Conference.
5. O. D. Despe et al., IEEE Trans. Nuclear Science Vol. NS-20, p. 71 (1973).
6. B. Zeidman et al., Nucl. Instr. Methods 118, 361 (1974)

#### NOTICE

This report was prepared as an account of work sponsored by the United States Government. Neither the United States nor the United States Energy Research and Development Administration, nor any of their employees, nor any of their contractors, subcontractors, or their employees, makes any warranty, express or implied, or assumes any legal liability or responsibility for the accuracy, completeness or usefulness of any information, apparatus, product or process disclosed, or represents that its use would not infringe privately owned rights.