

Silicon Microstructures and Microactuators for Compact Computer Disk Drives

Denny K. Miu¹
and
Yu-Chong Tai²

Abstract

In 1956, IBM shipped the first magnetic rigid disk drive. It was 24 inches in diameter, fitted inside a box the size of an industrial size refrigerator, stored 5 megabytes, and sold for tens of thousands of dollars. In 1983, Seagate shipped the first magnetic disk drive for the PC market which was 5-1/4 inch in diameter, fitted in a box half the size of a shoebox, also stored 5 megabytes and sold for less than \$1,500. In 1992, HP shipped what is still the world's smallest commercially available rigid disk drive, which is 1.3 inch in diameter, fitted in a box the size of a matchbook, stored 20 megabytes, and sold for \$150. In terms of both areal storage density and cost per megabyte, this progress has far exceeded the so-called 10-10 rules of the semiconductor industry, which is an order of magnitude improvement in 10 years. In fact, since 1991 magnetic recording disk drives have doubled in performance every eighteen months, and as a result, have maintained at least an order of magnitude cost advantage over solid-state memory and have long since surpassed optical recording in terms of storage density and capacity per drive.

It is projected that in another five years, the industry will be capable of delivering credit-card size gigabyte disk drive cartridges at about 10 cents per megabyte. At UCLA and Caltech, we believe silicon micromachining technology will play an important role in the fabrication of high-bandwidth, servo-controlled miniaturized microelectromechanical components for such super-high-capacity, super-compact computer disk drives. For the past four years, we have been collaborating on a number of industry and government supported joint research projects to develop the necessary technology building blocks for design of a low-cost integrated drive of the future. These efforts include the design and fabrication of a silicon read/write head,

microgimbaled with integrated electrical and mechanical interconnects, which targets the next-generation, 30 percent form factor pico-sliders. The efforts also include an electromagnetic piggyback planar microactuator for super-high-track-density applications. Both efforts utilize state-of-the-art silicon micromachining fabrication techniques.

Application background

Data storage devices such as magnetic recording rigid disk drives are key components of high-performance computer systems. With the ongoing significant increase in real-time usage of high-resolution, digitized graphical and video images in desktop computers, the development of smart portable information appliances for both home and office environments, and the emerging fiber-optic- and satellite-linked "information super-highway" international communication infrastructures, it will be of paramount importance to have available a new generation of super-compact, super-cost-effective, and super-high-performance recording devices for massive online computer data storage applications of the future.

Digital magnetic recording techniques of today provide storage at about 400 to 700 megabits of data per square inch of recording surface. This performance is extremely impressive considering that the areal density of the first commercial product was only 2 kilobits per square inch. Magnetic recording remains the most viable option compared to either optical storage or solid-state memory, including Flash. This is due to its cost-competitiveness in both component and media levels, overall recording density, access speed and data rate, reliability and nonvolatileness, and its proven ability to adapt to application-specific needs. More importantly, unlike optical recording where the recording density is currently limited by the wavelength of the illumination source and solid-state memory where density has always been hampered by advances in photolithographic and thermomechanical packaging techniques, the recording density of magnetic recording is currently orders of magnitude away from any physical limits.

¹Assistant Professor, Mechanical Engineering, University of California, Los Angeles.

²Assistant Professor, Electrical Engineering, California Institute of Technology.

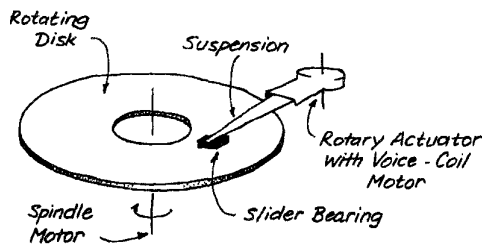

Figure 1. Major electromechanical components of a conventional high-performance rigid disk drive.

Figure 1 shows the major electromechanical components of the conventional single-actuator/pivot-bearing rigid disk drive design. In computer disk drives digital information is recorded in concentric tracks on rotating disks using miniaturized read/write (R/W) electromagnetic transducers mounted on self-lubricated sub-micron flying slider bearings. These R/W heads are connected to stainless steel suspension arms which are in turn connected to voice-coil actuators allowing cross-track seek and track-following motions.

Whereas bit density along the track is much higher than that of optical recording, track density of magnetic recording is typically much lower, although the access speed and data rate are much faster. Unlike optical recording, magnetic recording, in order to maintain high bit density, requires that the R/W heads must be placed very close to the recording media. On the other hand, to minimize latency and maximize data transfer rate, the relative speed between the transducers and the media must be very high. Therefore, tribomechanical and tribochemical wear are important problems and are inherent in any form of magnetic recording. In order to maintain proper head/media interface, the actuator arm/suspension that serves as the interconnect between the actuator and the sensor must be very compliant in the vertical, pitch, and roll directions. Unfortunately, such mechanical flexibilities tend to limit the bandwidth of the servo systems and therefore the track density. Furthermore, access time is severely limited by residual vibrations caused by the flexibility of the actuator-arm/suspension system, imposing another constraint on track density.

Mechanical challenges

Table 1 shows the approximate maximum areal density (MAD) of some typical commercial products of recent years as well as a projection of the performance required for products in the next decade. Note that areal data density is a combination of track density in the radial direction measured in tracks-per-inch (TPI) and bit density in the tangential direction measured in bits-per-inch (BPI).

Table 1. Approximate maximum areal density, measured in megabits per square inch, of recent commercial products and projections for the next decade.

	MAD	TPI	BPI
1971	1	200	5,000
1981	10	800	12,500
1991	100	2,000	50,000
1995	600	5,000	120,000
2001	10,000	25,000	400,000
2005	100,000	100,000	1,000,000

It is interesting to observe that historically BPI is at least an order of magnitude higher than TPI, resulting in more than a 20 to 1 aspect ratio in the lateral dimensions of the unit recording bit cell. It is also interesting to note that for the last two and a half decades, the industry has progressed on a steady 10x/decade (a +26 percent annual compound growth) improvement curve. However, since the early 90s, in order to stay competitive, it has accelerated onto a +60 percent annual growth curve. As a result, by the beginning of the next century, it is projected that the track density will have to be at least 25,000 TPI which corresponds to a track pitch of 1 μm and a tracking accuracy of less than 100 nm. Furthermore, in another five years, it is projected that the magnetic recording industry must deliver at least 100,000 TPI which corresponds to a track pitch of 250 nm and an astonishing servo resolution of 25 nm.

Besides the obvious contributing factors such as mechanical resonances, spindle runouts, temperature drifts, humidity variations, external shocks and vibrations, bearing hysteresis, cable bias, and so on, there are a number of significant sources of off-track errors that are unique to computer disk drives. As opposed to other applications where cost is not a primary concern, such as aerospace, sensors are used in disk drives only when they are absolutely necessary; otherwise the industry cannot remain cost competitive. Instead of using position sensors and servo patterns physically encoded on the disk surface, computer disk drive off-track errors are typically derived using the so-called embedded servo technique where the necessary off-track information is sandwiched within the magnetic data.

As the disk rotates, the magnetic R/W head will cross specially-coded magnetic servo patterns at regular intervals. After amplification, onboard demodulation electronics convert the encoded servo data into an off-track position error signal. This signal is then fed into a digital servo controller which compensates the error by driving the voice-coil actuator. Therefore, any nonlinearity and inaccuracy in the servo patterns caused by defects in the media, the head, and the electronics, shows up as measurable off-track error

that cannot be avoided. As bit density and track density increase, this becomes more and more significant.

In addition, besides track following, the servo system must also move the entire head/suspension assembly across the disk surface as fast as possible. This must be done in such a way as to minimize residual vibration. Typically the servo controller drives the actuator to follow an idealized velocity profile based on a rigid body model. The actuator velocity is not measured since there is neither a position sensor nor a velocity sensor. Instead, the velocity is estimated from the embedded off-track error using a reduced-order Kalman-type estimator. Therefore, seek settling of the actuator/suspension system is one of the biggest source of off-track error from both residual vibration of the inherently flexible mechanical structures and from the unavoidable velocity estimation error.

Obviously, the higher the servo bandwidth, the easier it is to correct these errors. Further, the higher the track density, the more important it is to have a high-bandwidth servo system. Currently, track density is less than 5,000 TDI and servo bandwidth is approximately 500 Hz which is limited by inherent in-the-loop mechanical resonances. For 25,000 TPI, it is projected that the servo bandwidth must be higher than 2 KHz. Furthermore, with spindle speed increased to 7,200 RPM, the required bandwidth increases to 3 or 4 KHz. It is well recognized throughout the industry that this level of performance simply cannot be achieved by an evolution of the existing hardware. The only solution is to use a dual-stage piggyback actuator system similar to that of the optical disk drives. By moving only the R/W head and not the entire slider/gimbal assembly, it is possible to design a high-bandwidth system without requiring unreasonable amount of power.

Aside from the aforementioned tracking control problems which mainly have to do with microactuation, there are other major technology issues pertinent to future generation super-compact disk drives, such as mechanical packaging, manufacturing, and electromechanical interconnect. To be relevant to disk drive applications, any proposed microactuator design must be consistent with these concerns. In drive design of today, much of these problems are solved by compromising and synergizing the designs of the individual components, that is, the R/W head, the stainless steel suspension and the voice-coil motor.

Therefore, from the perspective of a disk drive system, one cannot design the microactuator without worrying about how it will affect the rest of the interconnecting components. Moreover, one cannot design it without thinking about how it will preserve the traditional volumetric cost advantage, in dollars-per-megabyte, of magnetic over optical disk drives such as low disk-to-disk spacing, low media cost, and low unit cost of electromechanical components. Finally, one must also project how the proposed

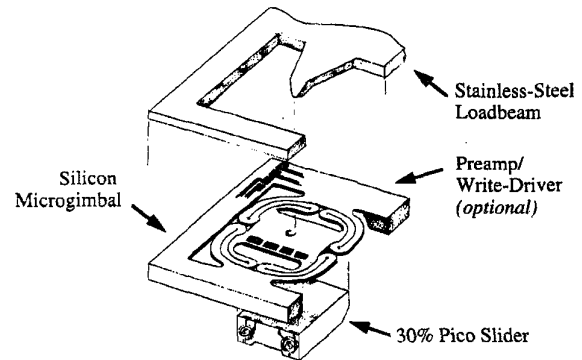

Figure 2. The proposed design concept of a hybrid silicon microgimbal/stainless steel suspension with built-in electrodes.

design will coincide with the miniaturization trend of the magnetic disk drive industry such that the design can lend itself to manufacturing automation and high-shock environments.

Silicon microstructures

Conventional suspensions are made of stainless steel of uniform thickness with the various features manufactured by a combination of chemical etching, precision stamping, and metal forming operations. As the drive form factor reduces to less than 2 inches in diameter and the slider bearing shrinks to about 1 by 1 mm in size, the suspension will be less than 1 cm long and the size of its gimbal, which is the structural component that connects the slider to the loadbeam of the suspension, will be less than 1.5 mm square. Therefore, it becomes increasingly difficult, if not altogether impossible, to fabricate the suspension/gimbal system using existing material and manufacturing techniques.

Typically, silicon is thought of as a brittle material which would not normally be used to construct flexible structures. However, brittle material is also elastic and the only difference is that unlike ductile material, it does not yield. It simply fractures when the stress reaches the ultimate strength. It is well known that the ultimate strength of silicon microstructures is orders of magnitude higher than that in bulk form. Therefore, silicon microsuspension can be made to be flexible even with a very high load-carrying capacity.

Figure 2 shows our proposed silicon microgimbal which has a number of potential operational advantages. First of all, since silicon is a brittle material, silicon microgimbals cannot be plastically deformed during manufacturing and handling. Therefore, quality assurance consists of only visual inspection. In comparison, plastic deformation of stainless steel suspensions is the major contributing factor of reduced production yield and in-drive performance

problems, which represents a significant cause of revenue loss.

In addition, due to the difference in process technology, much smaller features can be realized in silicon than in stainless steel by using various anisotropic wet and dry etching techniques, which provides much needed additional degrees of design freedom. For example, in our design, we fabricate intricate serpentine planar microsprints at the four corners of the microgimbal to satisfy the conflicting out-of-plane compliance, lateral stiffness, and shock resistance design requirements.

Furthermore, with silicon, it is relatively easy to incorporate electrodes or even pre-amps in the gimbal springs as well as an electrical coupler in the bonding area, thereby allowing the possibility of automating not only the mechanical but the electrical interconnect manufacturing procedures as well. Currently, in many state-of-the-art products, assembly of the head/gimbal/suspension subsystem represents nearly half of the total labor cost.

The design requirements of the silicon microgimbals are quite challenging. In addition to being soft enough for head/media compliance and stiff enough for tracking to increase servo bandwidth, they must also be strong enough to survive shocks on the order of hundreds of g's. In a way, designing microgimbals for the read/write heads is not much different from designing suspensions for our cars since automobile suspensions must be soft enough to give a smooth ride but yet stiff enough to handle fast turns. But most importantly, they must survive shocks with amplitudes well above normal operating conditions.

All suspension springs basically are composed of cantilever beams. The design trick of course, is to utilize cantilever beams of enough length such that for a given tip displacement, the operating strains are well below the yield or fracture point of the material. For applications where space is a concern, the obvious solution is to use helical springs which pack the most material into the smallest area. In the case of the microgimbal, the ideal solution would be to put individual helical springs at the four corners of the slider. Obviously, these soft springs must be designed such that they have sufficient lateral stiffness that requires careful optimization of the geometry, that is, aspect ratio, radius, and so on.

Given the form factor that we are designing for, it is nearly impossible to design helical springs out of stainless steel sheet. On the other hand, the advantage of using silicon is that very small features can be achieved. The difficulty however, is not so much in fabricating a planar helical spring but in fabricating the interconnect between the center of the spring and the slider or the substrate. Figure 3 shows the individual planar microsprints at the four corners of the microgimbals. These springs are a variation of the conventional helical springs. Instead of spiral beams,



Figure 3. SEM micrograph of a three-turn silicon microgimbal.

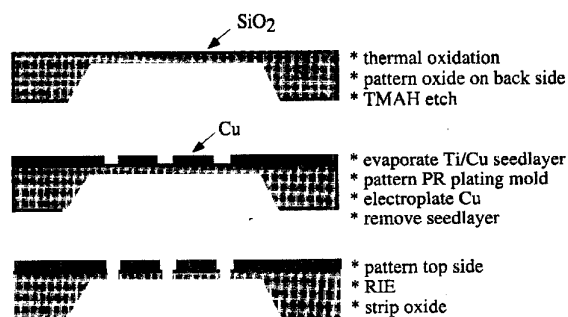

Figure 4. Processing steps for the silicon serpentine microgimbal.

which require interconnects, they are composed of alternating curved beams. Much work has been performed in optimizing the various beam widths and the stress relief holes around the turns.

The fabrication process for the silicon microgimbal/microsuspension is rather simple and consists of only two major steps. First, anisotropic chemical etching from the back creates a trapezoidal cavity that allows the attachment of the read/write slider directly under the center coupon. Second, reactive-ion etching (RIE) from the front using SF₆ plasma defines the microspring on the wafer. For etch stop, we use epi-wafers consisting of a 20 to 30 μm thick lightly-doped epitaxial layer on top of a 4 μm heavily boron-doped buried layer.

Figure 4 shows a summary of the complete processing steps which require only three masks. The silicon wafer is first thermally oxidized at 1050°C to form a 3,000 Å thick silicon oxide layer on the top and bottom surfaces. This serves as the protective coating for subsequent chemical etching as the well as insulation for the electrical interconnect. After patterning of the back side of the wafer, cavities are formed on the back side using an anisotropic chemical etchant called tetramethyl ammonium hydroxide (TMAH). Then a thin seedlayer consisting of 200 Å thick titanium and 1,000 Å copper are electron-beam evaporated on the top surface. Photoresist is then spinned and patterned using the sec-

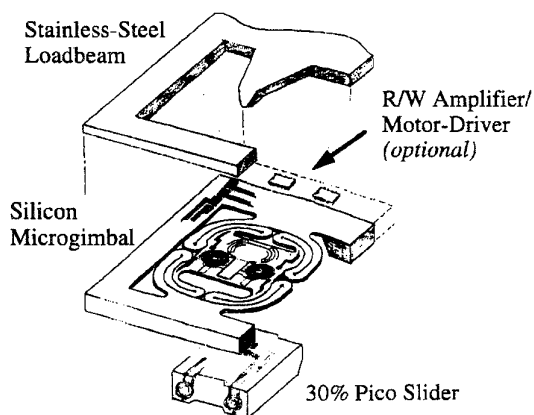

Figure 5. Design concept for a silicon micromachined electromagnetic piggyback planar microactuator for high TPI applications.

ond mask to form the electroplating mold for the electrodes. After electroplating, the seedlayer is removed and the third mask is used to pattern a thin layer of photoresist for RIE.

Silicon microactuators

Our next objective is to design and fabricate a piggyback microactuator that can be packaged to move the slider relative to the suspension to completely eliminate any in-the-loop structural resonances. This device must be very low-profile consistent with the disk-to-disk spacing requirement of future products. In addition, it must be mass-manufacturable and be able to operate in low-voltage, low-power environment. Furthermore, electrical interference must be at an absolute minimum in order not to degrade the read/write operations.

Figure 5 shows a design concept using the aforementioned silicon microgimbal as the structural platform. Instead of a solid coupon in the center, the read/write slider is now attached to the microgimbal by a pair of hair-pin-like planar springs designed to have maximum in-plane compliance while maintaining adequate out-of-plane, pitch and roll stiffnesses.

A pair of thin-film variable-reluctance microactuators are used to move the slider/recording head in the in-plane direction, each of which consists of two pieces. The stationary piece is mounted on the outside frame and is constructed of two layers of permalloy with a planar helical flat copper coil sandwiched between the two layers. The moving permalloy piece is attached to the slider and when a voltage is applied to the coil, magnetic force is exerted on the moving core, pulling it towards the stator and resulting in in-plane/cross-track micron-level fine motion of the read/write slider. This design has the important advantage that the required fabrication technology is very similar to

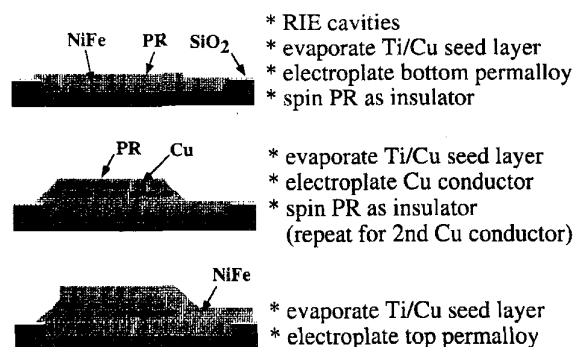

Figure 6. Process steps for the silicon electromagnetic microactuator.

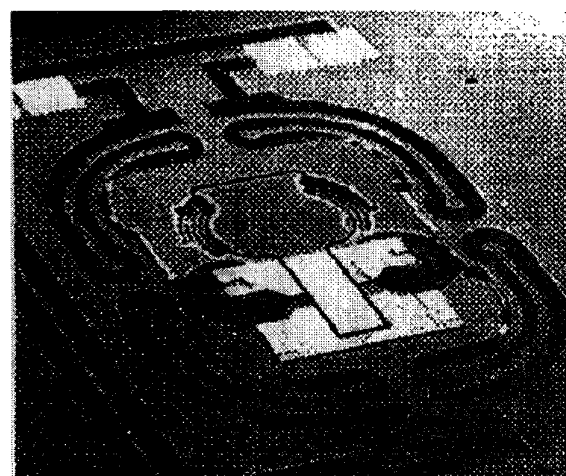

Figure 7. Micrograph of a fabricated prototype electromagnetic microactuator.

that of thin-film heads, which leverages the expertise of the magnetic recording industry. Figure 6 summarizes the fabrication process for the first prototype design and Figure 7 shows a fabricated prototype.

Integrated drive design

The paths of product development for magnetic disk drives are littered with thousands of technically great ideas whose only sins are being ahead of their time. With hindsight, it is clear that if one wishes the magnetic storage industry, or any industry, for that matter, to accept and to embrace any proposed changes in the design paradigm, one must not only solve the fundamental technical problems but must also provide a gradual and logical path such that the industry can proceed one technology step at a time. That is, as an industry, it will never allow itself to fly a new engine with an entirely new air-frame. For that reason, we focus our immediate effort on a number of strategically

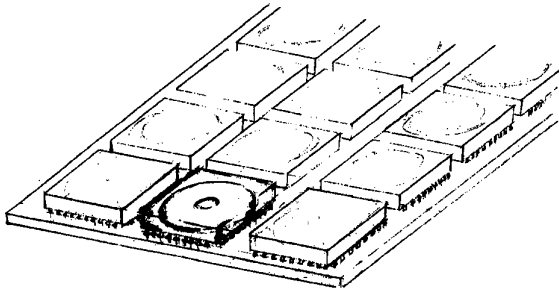

Figure 8. SCALED Technology—Super Compact Array of Low-cost Enormous-capacity Disk-drives.

important near-term research projects of fabricate silicon microstructures and microactuators using the proposed micromachining technology. Our self-imposed constraint is that these proposed silicon devices must be a one-to-one replacement to its conventional equivalent, requiring no or at least minimal changes in the drive design.

At the same time, we envision and position these silicon devices to be the enabling precursor technology necessary for the achievement of a truly integrated design of the future. Figure 8 illustrates our futuristic product concept for the high-performance super-compact VLSI-level data storage array. At a recording density of 10 gigabits per square inch, the recording capacity for each of the 2 centimeters diameter, 0.5 centimeter high modules is approximately 2 gigabytes of digital data, which corresponds roughly to one hour of compressed video. At that form factor, they are compatible with surface-mounting technology and as an array, will significantly increase the on-line storage capacity, access speed, data rate, redundancy, and reliability of future products.

Figure 9 shows a possible design of silicon micromachined microelectromechanical actuator array which would allow an integrated design paradigm to take place. Our vision is that disk drives of the future shall consist of only two major components—a stack of rotating disks containing the recording media and a stack of stationary silicon disks sandwiched between the recording disks, consisting of arrays of high-resolution, high-bandwidth microactuator-suspension-read-write-heads to accomplish the required positioning and recording operations. These integrated microdevices will perform all of the sensing, actuation, signal processing, and control functions in a single low-cost, mass-manufacturable, silicon-based package. This eliminates much of the costly and complicated external electrical and electromechanical interconnections that exist in the conventional disk drive design. Perhaps one day we shall think of such silicon micromachined integrated disk-drives (IDs) the same way we think of integrated circuits (ICs) today, a logical and rather obvious technology evolution consistent with miniaturization and performance improvement.

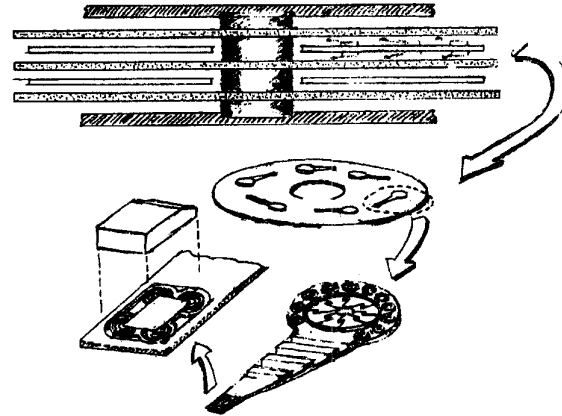

Figure 9. Array of articulated torsional bearings with integrated electromagnetic microactuators.

Summary

Silicon micromachining techniques offer many exciting opportunities for fabricating both passive microstructures and active electromagnetic microactuators for significant form factor reduction and increase in recording density of future magnetic recording rigid disk drives. In this overview paper, see also [1], we have presented some recent results and novel product concepts. In other related papers, we have documented in detail the results related to design optimization, process refinement, and static/dynamic testing.

Acknowledgment

The work was conducted at the *Caltech Micromachining Laboratory* with support from the University of California MICRO program and matching funds from Applied Magnetics, Hewlett-Packard, IBM, Magnacomp, Maxtor, Quantum, Read-Rite and Seagate Technologies, and the National Storage Industry Consortium (NSIC). The results are the combined efforts of our many colleagues, Amish Desai, Wen Hsieh, Raanan Miller, Weilong Tang, Viktoria Temesvary, and Shuyun Wu.

Publications

- [1] D.K. Miu and Y.-C. Tai, "Silicon Microstructures and Microactuators for Compact Computer Disk Drives," *IEEE Control Systems*, Dec. 1994, pp. 52–57.
- [2] D.K. Miu and Y.-C. Tai, "Silicon Micromachined SCALED Technology," to appear in *IEEE Trans. Industrial Electronics*, Vol. 42, No. 3, June 1995; also *Proc. 1993 JSME Int'l Conf. Advanced Mechatronics*, Tokyo, Japan, Aug. 2–4, pp. 527–532.
- [3] D.K. Miu et al., "Silicon Micromachined Microstructures for Super-Compact Magnetic Recording Rigid Disk Drives,"

Fourteenth IEEE Symposium on Mass Storage Systems

Proc. 7th Int'l Conf. Solid-State Sensors and Actuators, Yokohama, Japan, June 7–10, 1993, pp. 771–773.

- [4] D.K. Miu et al., "Silicon Microgimbals for Super-Compact Magnetic Recording Rigid Disk Drives," *ASME Advances in Information Storage Systems*, Vol. 5, 1993, pp. 149–152.
- [5] V. Temesvary et al., "Design, Fabrication and Testing of Silicon Microgimbals for Super-Compact Rigid Disk Drives," *IEEE/ASME Journal of MEMS*, Vol. 4, No. 1, Mar. 1995, pp. 18–27.
- [6] W. Tang et al., "Silicon Micromachined Electromagnetic Microactuators for Rigid Disk Drives," to be presented at the *INTEMAG '95 Conf.*, San Antonio, TX.