



# Asteroid Retrieval Feasibility Study

2 April 2012

Prepared for the:

Keck Institute for Space Studies  
California Institute of Technology  
Jet Propulsion Laboratory  
*Pasadena, California*



## Authors and Study Participants

NAME	Organization	E-Mail	Signature
John Brophy	Co-Leader / NASA JPL / Caltech	<a href="mailto:john.r.brophy@jpl.nasa.gov">john.r.brophy@jpl.nasa.gov</a>	
Fred Culick	Co-Leader / Caltech	<a href="mailto:fecfly@caltech.edu">fecfly@caltech.edu</a>	
Louis Friedman	Co-Leader / The Planetary Society	<a href="mailto:louis.friedman@planetary.org">louis.friedman@planetary.org</a>	
Carlton Allen	NASA JSC	<a href="mailto:Carlton.C.Allen@nasa.gov">Carlton.C.Allen@nasa.gov</a>	
David Baughman	Naval Postgraduate School	<a href="mailto:davidbaughman@me.com">davidbaughman@me.com</a>	
Julie Bellerose	NASA ARC/Carnegie Mellon University	<a href="mailto:julie.bellerose@nasa.gov">julie.bellerose@nasa.gov</a>	
Bruce Betts	The Planetary Society	<a href="mailto:bruce.betts@planetary.org">bruce.betts@planetary.org</a>	
Mike Brown	Caltech	<a href="mailto:mbrown@caltech.edu">mbrown@caltech.edu</a>	
Michael Busch	UCLA	<a href="mailto:mbusch@ess.ucla.edu">mbusch@ess.ucla.edu</a>	
John Casani	NASA JPL	<a href="mailto:John.R.Casani@jpl.nasa.gov">John.R.Casani@jpl.nasa.gov</a>	
Marcello Coradini	ESA	<a href="mailto:Marcello.Coradini@jpl.nasa.gov">Marcello.Coradini@jpl.nasa.gov</a>	
John Dankanich	NASA GRC	<a href="mailto:John.Dankanich@nasa.gov">John.Dankanich@nasa.gov</a>	
Paul Dimotakis	Caltech	<a href="mailto:Paul.E.Dimotakis@jpl.nasa.gov">Paul.E.Dimotakis@jpl.nasa.gov</a>	
Martin Elvis	Harvard-Smithsonian Center for Astrophysics	<a href="mailto:elvis@cfa.harvard.edu">elvis@cfa.harvard.edu</a>	
Ian Garrick-Bethel	UCSC	<a href="mailto:igarrick@ucsc.edu">igarrick@ucsc.edu</a>	
Bob Gershman	NASA JPL	<a href="mailto:Robert.Gershman@jpl.nasa.gov">Robert.Gershman@jpl.nasa.gov</a>	
Tom Jones	Florida Institute for Human and Machine Cognition	<a href="mailto:skywalking@comcast.net">skywalking@comcast.net</a>	
Damon Landau	NASA JPL	<a href="mailto:Damon.Landau@jpl.nasa.gov">Damon.Landau@jpl.nasa.gov</a>	
Chris Lewicki	Arkyd Astronautics	<a href="mailto:chris@arkyd.com">chris@arkyd.com</a>	
John Lewis	University of Arizona	<a href="mailto:jsl@U.Arizona.edu">jsl@U.Arizona.edu</a>	
Pedro Llanos	USC	<a href="mailto:llanos@usc.edu">llanos@usc.edu</a>	
Mark Lupisella	NASA GSFC	<a href="mailto:mark.l.lupisella@nasa.gov">mark.l.lupisella@nasa.gov</a>	
Dan Mazanek	NASA LaRC	<a href="mailto:Daniel.D.Mazanek@nasa.gov">Daniel.D.Mazanek@nasa.gov</a>	
Prakhar Mehrotra	Caltech	<a href="mailto:prakhar@caltech.edu">prakhar@caltech.edu</a>	
Joe Nuth	NASA GSFC	<a href="mailto:joseph.a.nuth@nasa.gov">joseph.a.nuth@nasa.gov</a>	
Kevin Parkin	NASA ARC/Carnegie Mellon University	<a href="mailto:Kevin.L.Parkin@nasa.gov">Kevin.L.Parkin@nasa.gov</a>	
Rusty Schweickart	B612 Foundation	<a href="mailto:rs@well.com">rs@well.com</a>	
Guru Singh	NASA JPL	<a href="mailto:gurkirpal.singh@jpl.nasa.gov">gurkirpal.singh@jpl.nasa.gov</a>	
Nathan Strange	NASA JPL	<a href="mailto:Nathan.J.Strange@jpl.nasa.gov">Nathan.J.Strange@jpl.nasa.gov</a>	
Marco Tantardini	The Planetary Society	<a href="mailto:marco.tantardini@gmail.com">marco.tantardini@gmail.com</a>	
Brian Wilcox	NASA JPL	<a href="mailto:Brian.H.Wilcox@jpl.nasa.gov">Brian.H.Wilcox@jpl.nasa.gov</a>	
Colin Williams	NASA JPL	<a href="mailto:Colin.P.Williams@jpl.nasa.gov">Colin.P.Williams@jpl.nasa.gov</a>	
Willie Williams	NASA JSC	<a href="mailto:Willie.B.Williams@nasa.gov">Willie.B.Williams@nasa.gov</a>	
Don Yeomans	NASA JPL	<a href="mailto:Donald.K.Yeomans@jpl.nasa.gov">Donald.K.Yeomans@jpl.nasa.gov</a>	

## Table of Contents

	Page
<b>Executive Summary</b> .....	5
<b>I. Introduction</b> .....	7
Why Now?.....	8
<b>II. Rationale and Benefits</b> .....	9
Synergy with Near-Term Human Exploration.....	9
Expansion of International Cooperation in Space.....	10
Synergy with Planetary Defense.....	11
Exploitation of Asteroid Resources.....	12
Public Engagement.....	13
<b>III. Mission Overview &amp; Safety Considerations</b> .....	14
Final Destination.....	15
Safety.....	15
<b>IV. Target Discovery and Characterization</b> .....	16
Asteroid Type.....	16
Discovery and Characterization Techniques.....	16
Observation Campaign.....	19
Alternative Approach.....	21
<b>V. Flight System Design</b> .....	22
Electric Propulsion (EP) Subsystem.....	22
Reaction Control Subsystem (RCS).....	24
Electrical Power Subsystem (EPS).....	24
Communications Subsystem.....	25
Master Equipment List (MEL).....	25
Alternative Flight System Architecture.....	26
Capture Mechanism.....	27
<b>VI. Mission Design</b> .....	28
Earth Departure, Rendezvous and Pre-Capture Operations.....	28
Pick Up a Rock Alternative Mission Approach.....	30
Get a Whole One Pre-Capture Operations.....	31
Capture and Post-Capture Operations.....	32
Getting to Lunar Orbit.....	36
Cislunar Operations.....	37
Cost Estimate.....	39
<b>VII. SEP Technology and Required Development</b> .....	41
Solar Array Technology.....	42
Electric Propulsion Technology.....	43
Near-Term Application of SEP Technology for Human Missions to NEAs....	43
<b>VIII. Recommended Near-Term Follow-on Activities</b> .....	46
Observation Campaign.....	46
Mission Design.....	46
Capture Mechanism Development.....	46
SEP Subsystem PPU Development.....	46
<b>IX. Conclusions</b> .....	47
<b>Acknowledgements</b> .....	48
<b>References</b> .....	49

## EXECUTIVE SUMMARY

This report describes the results of a study sponsored by the Keck Institute for Space Studies (KISS) to investigate the feasibility of identifying, robotically capturing, and returning an entire Near-Earth Asteroid (NEA) to the vicinity of the Earth by the middle of the next decade. The KISS study was performed by people from Ames Research Center, Glenn Research Center, Goddard Space Flight Center, Jet Propulsion Laboratory, Johnson Space Center, Langley Research Center, the California Institute of Technology, Carnegie Mellon, Harvard University, the Naval Postgraduate School, University of California at Los Angeles, University of California at Santa Cruz, University of Southern California, Arkyd Astronautics, Inc., The Planetary Society, the B612 Foundation, and the Florida Institute for Human and Machine Cognition. The feasibility of an asteroid retrieval mission hinges on finding an overlap between the smallest NEAs that could be reasonably discovered and characterized and the largest NEAs that could be captured and transported in a reasonable flight time. This overlap appears to be centered on NEAs roughly 7 m in diameter corresponding to masses in the range of 250,000 kg to 1,000,000 kg. To put this in perspective, the Apollo program returned 382 kg of Moon rocks in six missions and the OSIRIS-REx mission proposes to return at least 60 grams of surface material from a NEA by 2023. The present study indicates that it would be possible to return a ~500,000-kg NEA to high lunar orbit by around 2025.

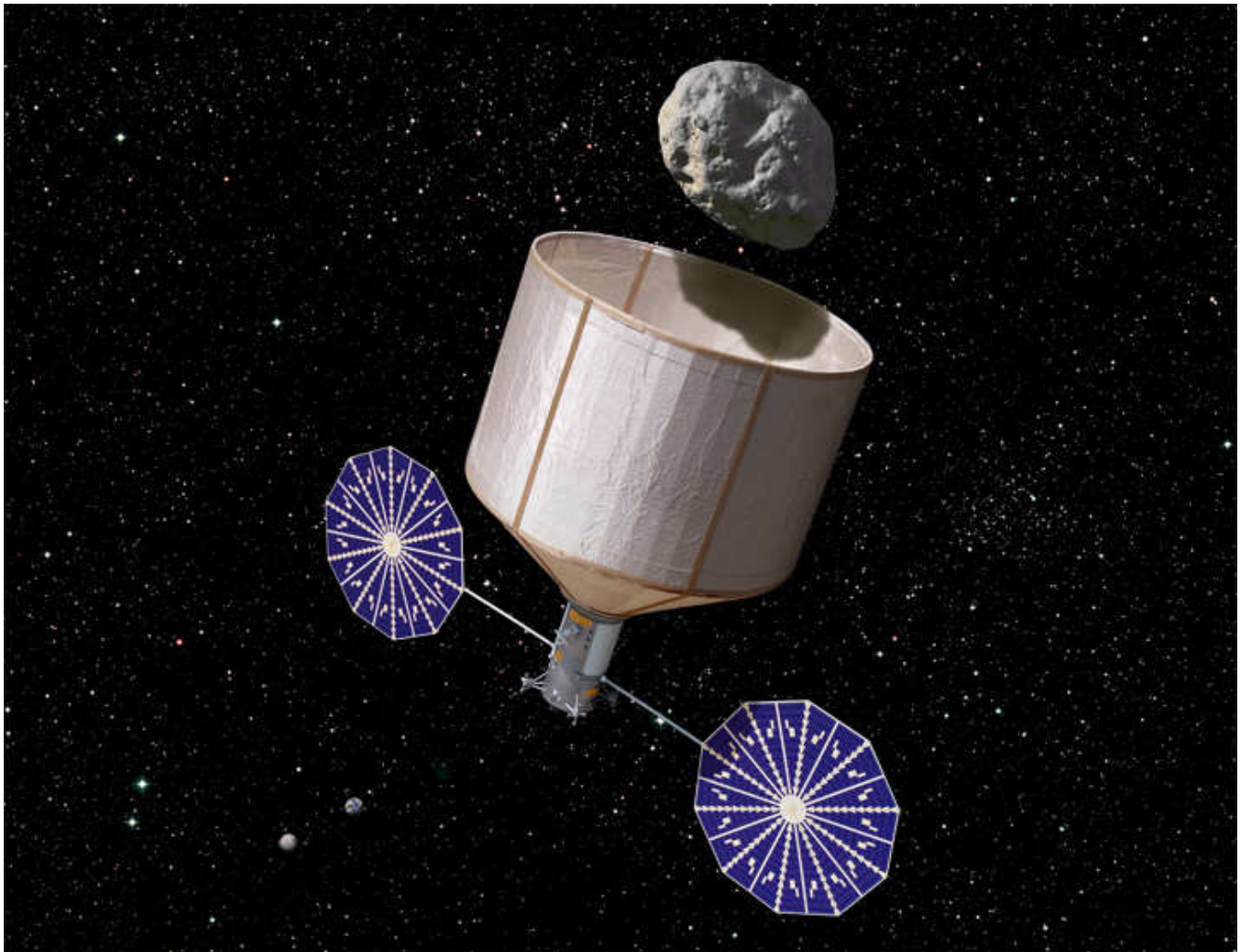


Illustration of an asteroid retrieval spacecraft in the process of capturing a 7-m, 500-ton asteroid.  
(Image Credit: Rick Sternbach / KISS)

The idea of exploiting the natural resources of asteroids dates back over a hundred years, but only now has the technology become available to make this idea a reality. The feasibility is enabled by three key developments: the ability to discover and characterize an adequate number of sufficiently small near-Earth asteroids for capture and return; the ability to implement sufficiently powerful solar electric propulsion systems to enable transportation of the captured NEA; and the proposed human presence in cislunar space in the 2020s enabling exploration and exploitation of the returned NEA.

Placing a 500-t asteroid in high lunar orbit would provide a unique, meaningful, and affordable destination for astronaut crews in the next decade. This disruptive capability would have a positive impact on a wide range of the nation's human space exploration interests. It would provide a high-value target in cislunar space that would require a human presence to take full advantage of this new resource. It would offer an affordable path to providing operational experience with astronauts working around and with a NEA that could feed forward to much longer duration human missions to larger NEAs in deep space. It would provide an affordable path to meeting the nation's goal of sending astronauts to a near-Earth object by 2025. It represents a new synergy between robotic and human missions in which robotic spacecraft retrieve significant quantities of valuable resources for exploitation by astronaut crews to enable human exploration farther out into the solar system. A key example of this is that water or other material extracted from a returned, volatile-rich NEA could be used to provide affordable shielding against galactic cosmic rays. The extracted water could also be used for propellant to transport the shielded habitat. These activities could jump-start an entire *in situ* resource utilization (ISRU) industry. The availability of a multi-hundred-ton asteroid in lunar orbit could also stimulate the expansion of international cooperation in space as agencies work together to determine how to sample and process this raw material. The capture, transportation, examination, and dissection of an entire NEA would provide valuable information for planetary defense activities that may someday have to deflect a much larger near-Earth object. Finally, placing a NEA in lunar orbit would provide a new capability for human exploration not seen since Apollo. Such an achievement has the potential to inspire a nation. It would be mankind's first attempt at modifying the heavens to enable the permanent settlement of humans in space.

The report that follows outlines the observation campaign necessary to discover and characterize NEAs with the right combination of physical and orbital characteristics that make them attractive targets for return. It suggests that with the right ground-based observation campaign approximately five attractive targets per year could be discovered and adequately characterized. The report also provides a conceptual design of a flight system with the capability to rendezvous with a NEA in deep space, perform *in situ* characterization of the object and subsequently capture it, de-spin it, and transport it to lunar orbit in a total flight time of 6 to 10 years. The transportation capability would be enabled by a ~40-kW solar electric propulsion system with a specific impulse of 3,000 s. Significantly, the entire flight system could be launched to low-Earth orbit on a single Atlas V-class launch vehicle. With an initial mass to low-Earth orbit (IMLEO) of 18,000 kg, the subsequent delivery of a 500-t asteroid to lunar orbit represents a mass amplification factor of about 28-to-1. That is, 28 times the mass launched to LEO would be delivered to high lunar orbit, where it would be energetically in a favorable location to support human exploration beyond cislunar space. Longer flight times, higher power SEP systems, or a target asteroid in a particularly favorable orbit could increase the mass amplification factor from 28-to-1 to 70-to-1 or greater. The NASA GRC COMPASS team estimated the full life-cycle cost of an asteroid capture and return mission at ~\$2.6B.

## I. INTRODUCTION

The idea to exploit the natural resources of asteroids is older than the space program. Konstantin Tsiolkovskii included in *The Exploration of Cosmic Space by Means of Reaction Motors*, published in 1903, the “exploitation of asteroids” as one of his fourteen points for the conquest of space [1]. More recently this idea was detailed in John Lewis’ book *Mining the Sky* [2], and it has long been a major theme of science fiction stories [3]. The difference today is that the technology necessary to make this a reality is just now becoming available. To test the validity of this assertion, NASA sponsored a small study in 2010 to investigate the feasibility of identifying, robotically capturing, and returning to the International Space Station (ISS), an entire small near-Earth asteroid (NEA) – approximately 2-m diameter with a mass of order 10,000 kg – by 2025 [4]. This NASA study concluded that while challenging there were no fundamental show-stoppers that would make such a mission impossible. It was clear from this study that one of the most challenging aspects of the mission was the identification and characterization of target NEAs suitable for capture and return.

In 2011 the Keck Institute for Space Studies (KISS) [5] sponsored a more in-depth investigation of the feasibility of returning an entire NEA to the vicinity of the Earth. The KISS study focused on returning an asteroid to a high lunar orbit instead of a low-Earth orbit. This would have several advantages. Chief among these is that it would be easier from a propulsion standpoint to return an asteroid to a high lunar orbit rather than take it down much deeper into the Earth’s gravity well. Therefore, larger, heavier asteroids could be retrieved. Since larger asteroids are easier to discover and characterize this helps to mitigate one of the key feasibility issues, i.e., identifying target asteroids for return. The KISS study eventually settled on the evaluation of the feasibility of retrieving a 7-m diameter asteroid with a mass of order 500,000 kg. To put this in perspective, the Apollo program returned 382 kg of moon rocks in six missions. The OSIRIS-REx mission [6] proposes to return at least 60 grams of surface material from a NEA by 2023. The Asteroid Capture and Return (ACR) mission, that is the focus of this KISS study, seeks return a 500,000-kg asteroid to a high lunar orbit by the year 2025.

The KISS study enlisted the expertise of people from around the nation including representatives from most of the NASA centers (ARC, GRC, GSFC, JPL, JSC, and LaRC), several universities (Caltech, Carnegie Mellon, Harvard, Naval Postgraduate School, UCLA, UCSC, and USC), as well as several private organizations (Arkyd Astronautics, Inc., The Planetary Society, B612 Foundation, and Florida Institute for Human and Machine Cognition). The people listed below participated in the KISS study and developed the contents of this report. The study was conducted over a six-month period beginning with a four-day workshop in September 2011 followed by a two-day workshop in February 2012, and concluding with the submission of this report in April 2012.

John Brophy (Co-Leader / NASA JPL)  
Fred Culick (Co-Leader / Caltech)  
Louis Friedman (Co-Leader / The Planetary Society)  
Carlton Allen (NASA JSC)  
David Baughman (Naval Postgraduate School)  
Julie Bellerose (NASA ARC)  
Bruce Betts (The Planetary Society)  
Mike Brown (Caltech)  
Michael Busch (UCLA/NRAO)  
John Casani (NASA JPL)  
Marcello Coradini (ESA)  
John Dankanich (NASA GRC)  
Paul Dimotakis (Caltech)  
Martin Elvis (Harvard-Smithsonian Center for Astrophysics)

Ian Garrick-Bethel (UCSC)  
Bob Gershman (NASA JPL)  
Tom Jones (Florida Institute for Human and Machine Cognition)  
Damon Landau (NASA JPL)  
Chris Lewicki (Arkyd Astronautics, Inc)  
John Lewis (University of Arizona)  
Pedro Llanos (USC)  
Mark Lupisella (NASA GSFC)  
Dan Mazanek (NASA LaRC)  
Prakhar Mehrotra (Caltech)  
Joe Nuth (NASA GSFC)  
Kevin Parkin (NASA ARC)  
Rusty Schweickart (B612 Foundation)  
Guru Singh (NASA JPL)  
Nathan Strange (NASA JPL)  
Marco Tantardini (The Planetary Society)  
Brian Wilcox (NASA JPL)  
Colin Williams (NASA JPL)  
Willie Williams (NASA JSC)  
Don Yeomans (NASA JPL)

The KISS study consisted primarily of two workshops, the first held in September 2011 lasting for four days, and the second a two-day workshop in February 2012, with additional work performed between workshops. The three main objectives of the KISS study were to:

1. Determine the feasibility of robotically capturing and returning a small near-Earth asteroid to the vicinity of the Earth using technology available in this decade.
2. Identify the benefits to NASA, the scientific community, the aerospace community, and the general public of such an endeavor.
3. Identify how this endeavor could impact NASA's and the international space community's plans for human exploration beyond low-Earth orbit

A mission to retrieve an entire near-Earth asteroid must successfully address the following three key feasibility issues:

1. How to discover and characterize a sufficient number of candidate asteroids to enable robust mission planning for a launch around 2020?
2. How to capture and de-spin an asteroid with a mass of order 500,000 kg in deep space?
3. How to safely transport the captured 500,000-kg asteroid back to the Earth-Moon system and place it in a high lunar orbit?

The feasibility of capturing and returning an entire NEA to a high lunar orbit, as well as the benefits to NASA and the nation are discussed in the sections below.

### **Why Now?**

Given that the idea to exploit the natural resources of asteroids is very old, what has changed that warrants serious investigation into the feasibility of capturing and returning entire near-Earth asteroids to the Earth-Moon system? The answer is, as mentioned in the opening paragraph above, that the technology necessary to make this possible is just now becoming available. There are three key enabling elements: 1) We now have ability to discover and characterize a sufficient number of sufficiently small near-Earth asteroids; 2) Sufficiently powerful solar electric propulsion systems necessary to transport a captured NEA are also just now becoming available; and 3) NASA is planning to have an human exploration capability in cislunar space in a time frame that is compatible with when an asteroid could be delivered to lunar orbit. Placing a 500-t asteroid there would provide a unique, meaningful, and easy-to-reach destination for exploration by astronaut crews in the next decade.



## II. RATIONALE AND BENEFITS

Before discussing the feasibility of returning a 500 metric ton asteroid to lunar orbit, it is important to identify why such an endeavor is important, what benefits it would provide to NASA, the nation, and the international community, and why the public should care. Five general categories of benefits from the return of an entire NEA were identified: 1) Synergy with near-term human exploration; 2) Expansion of international cooperation in space; 3) Synergy with planetary defense; 4) Exploitation of asteroid resources to the benefit of human exploration beyond the Earth-moon system; and 5) Public engagement.

### **Synergy with Near-Term Human Exploration**

The Asteroid Capture-and-Return mission (ACR) concept fits well within the current human spaceflight goals of NASA and its international partners. NASA is currently pursuing the goal of sending an astronaut expedition to a near-Earth asteroid sometime around 2025. A number of key milestones must be accomplished before that would be possible:

- a) A search for smaller, more numerous, and dynamically accessible NEA targets.
- b) Development of a deep-space crewed spacecraft and heavy-lift launch system.
- c) One or more robotic precursors designed to characterize the general properties of NEAs.
- d) A scout mission to the likely human target to enhance safety and enable detailed mission planning.

The ACR mission concept offers an affordable, intermediate performance goal that could maintain momentum toward deep space expeditions and reduce programmatic risk. It would support human deep-space exploration in the following six ways:

First, the ACR mission could partially fulfill the role of a robotic precursor, yet provide far more information about asteroid structure, composition, and mechanical properties through the extensive field investigation it would enable. The mission would increase greatly our ability to perform complex scientific and flight operations around NEAs, well beyond levels contemplated by currently planned robotic missions. For example, the ACR mission would require mastery of autonomous proximity operations around a small body, part of a skill set that is directly applicable to a wide variety of beyond-LEO missions. A NEA retrieval mission – if conducted promptly – could feed experience and hardware forward into plans for a series of human NEA expeditions in deep space. The risk reduction and hardware validation obtained via a retrieval mission would aid subsequent human exploration planning. This gain in capability would build confidence in and reduces the risk of the first human mission to a NEA.

Second, by making available hundreds of tons of asteroidal material within the Earth-Moon system, ACR mission concept would enable astronaut visits that would take only a few weeks, not the half a year or more required for even the most accessible NEA targets. Compared to a deep-space NEA mission, a “local” visit to the captured ACR object would enable the crew to spend a much higher fraction of their mission time actually working at the object. Such a “local asteroid” mission would clearly be a bridge between LEO operations and full-fledged deep-space NEA expeditions. The shorter duration would also reduce significantly the radiation hazard facing the crew.

Third, the ACR mission concept would put bulk asteroidal material within reach of Earth-Moon L2 (EM L2) facilities and transport systems, now being evaluated by NASA as a waypoint to lunar, asteroid, and Mars system destinations. Visits from the L2 outpost to this small captured asteroid would be an attractive sortie option for astronaut crews, providing opportunities for sample return, in-depth scientific examination, and demonstration of resource processing methods. The ACR mission would enhance the scientific, operational, and economic value of establishing a human-tended outpost at EM L2.

Fourth, providing hundreds of tons of asteroidal material in cislunar space would open the door to large-scale use of extraterrestrial resources by NASA and its commercial partners. Extraction of propellants, bulk shielding, and life support fluids from this first captured asteroid could jump-start an entire space-based industry. Our space capabilities would finally have caught up with the speculative attractions of using space resources *in situ*. One of the simplest but highly leveraged benefits from these resources might be the provision of bulk shielding material for future deep-space expeditions—a simple but effective countermeasure to galactic cosmic ray exposure.

Fifth, the public would clearly see the results from human exploration once astronauts begin the lengthy, challenging task of examining and “dissecting” a ~ 500 metric ton asteroid. This ongoing robotic and astronaut operation would provide a steady stream of “real-time exploration” results to a public attracted to the scientific unknowns and the economic potential of this captured asteroid. Eventually, commercial consortia should be given access to the object to test resource processing methods and compete for resource production rights on this and other objects.

Sixth, the development of a high-power (40-kW class) solar electric propulsion system would provide a high-performance transportation capability that would benefit other human missions in deep space through cargo delivery and hardware pre-deployment. It would also provide a stepping stone to even higher power SEP vehicles that could be used directly for crew transportation to NEAs and beyond.

Taken together, these attributes of an ACR mission would endow NASA (and its partners) with a new demonstrated capability in deep space that hasn’t been seen since Apollo. Once astronaut visits to the captured object begin, NASA would be putting human explorers in contact with an ancient, scientifically intriguing, and economically valuable body beyond the Moon, an achievement that would compare very favorably to any attempts to repeat the Apollo lunar landings.

### **Expansion of International Cooperation in Space**

The retrieval of a several-hundred-ton carbonaceous asteroid would present unparalleled opportunities for international cooperation. The retrieval could be carried out under the same philosophy as the Apollo program, “in peace for all mankind,” but with a significant advantage. An international panel could be formed to oversee both curation of the body and the review of proposals for its study. The demand for samples for engineering and scientific study of the carbonaceous chondrite material by academic, governmental, and industrial laboratories – usually severely hampered by lack of pristine material – could be met generously. Samples could be returned to Earth for study, whereas microgravity processing experiments of the sort envisioned above could be carried out *in situ* in its parking orbit. Selected spacefaring nations would have access to the body under the oversight of the international curatorial panel. Nations without the ability to fly missions to the body would be encouraged to form teaming arrangements and propose jointly with those who can access it.

As a natural step in moving human exploration capabilities from the International Space Station (ISS) into cislunar space, then beyond, the ACR mission concept would offer many opportunities for international participation.

1. Our current knowledge of the composition and surface properties of asteroids results from an international scientific exploration effort, including probes from NASA, JAXA, and ESA (e.g. NEAR-Shoemaker, Dawn, Hayabusa, and Rosetta). The U.S. and Japan have flown spacecraft to rendezvous with Near-Earth Object (NEOs), and Japan has returned samples from near-Earth asteroid 25143 Itokawa. Following up on the ESA Don Quijote study, the European Union has now funded an international consortium for a planetary defense study to organize, prepare and implement mitigation measures. Skills gained from all of these encounters might be combined to furnish the spacecraft and scientific instrument complement for the proposed ACR mission. Examples of contributed hardware to the ACR mission could include: launch systems, orbit transfer stages, solar

arrays, ion thrusters, remote sensing and imaging instruments, asteroid capture and retention systems, communications avionics and antennae, and docking hardware for future astronaut visits.

2. Once the target asteroid arrives in cislunar space, the mission partners could open the many tons of asteroid mass to international sampling, study, and economic assay, extending the collaboration over many years. Follow-up scientific and processing visits to the returned NEA could be a collaborative effort, combining partner investigations and hardware to assess the nature of the object and then begin its industrial processing. The attraction of such an intriguing object in cislunar space would likely draw new partners and serve to expand today's ISS coalition.
3. The proposed ACR mission concept would lend itself also to the developing international framework for planetary defense from a NEO impact. Space agencies meeting under the auspices of the United Nations Committee on the Peaceful Uses of Outer Space are discussing the planning and operations required for an international mission demonstrating the techniques that would be required to deflect a hazardous asteroid. [7,8] In addition, the NASA Advisory Council's ad hoc Task Force on Planetary Defense recommended in 2010 that NASA pursue leadership of an international deflection mission as its long-term planetary defense objective [9]. Because the proposed ACR mission would, by definition, be a safe "deflection" of a non-hazardous asteroid, the mission concept would fit very well into this multinational effort, one that would also offer numerous scientific and human exploration benefits.
4. Russia, Europe, and Japan are all evaluating future human spaceflight systems, first to reach and service the ISS, but with application to deep-space transport. NASA's ISS partners wish to build on their Space Station achievements by participating in future deep-space expeditions. If the proposed ACR mission made available tons of asteroidal material in cislunar space, it would spur collaborative efforts to access this new natural satellite. Experience gained via human expeditions to the small returned NEA would transfer directly to follow-on international expeditions beyond the Earth-Moon system: to other near-Earth asteroids, Phobos and Deimos, Mars and potentially someday to the main asteroid belt.

### **Synergy with Planetary Defense**

An asteroid return mission would bring broader attention to the subject of near-Earth asteroids and therefore greater understanding and attention to the planetary defense challenge element of NEOs.

From a technical standpoint an asteroid return mission would enable significant progress in the following areas relative to planetary defense:

1. Anchoring. Many options for more efficient and capable deflection of NEOs would open up if we develop reliable robotic anchoring capability. The latest time to act prior to impact could be significantly delayed if robust techniques are available. Anchoring is the key to enable many of them.
2. Structural characterization, especially of the surface layers. Kinetic impact is today one of the prime deflection technologies available. Yet its effectiveness is highly uncertain due to the (so called) momentum multiplier (beta) variability. Ejecta (at greater than escape velocity) from a kinetic impact may multiply the impactor momentum transferred to the NEO by a factor from 2-10 or more. Structural characterization of the surface layers may reduce this uncertainty to a factor of 2 or less.
3. Dust environment. The dust environment is expected to be highly variable and object dependent. Nevertheless, understanding the forces triggering dust levitation and settling behavior are important for the gravity tractor (GT) concept in which SEP exhaust impingement on the asteroid could create

a dust hazard. As a minimum greater knowledge here would enable more efficient system designs and a better understanding of stand-off requirements.

4. Proximity operations. Techniques for proximity operations and NEO navigation gained from returning an asteroid would be directly transferable to planetary defense planning and implementation.

### **Exploitation of Asteroid Resources**

From a long-term architectural point of view, the ability to test resource extraction processes and enable commercial resource production ideas to be applied to the captured NEA would pave the way for use of asteroidal materials in human deep-space expeditions, greatly reducing required up-mass from Earth, and thus the cost, of such missions. A 500-t, carbonaceous C-type asteroid may contain up to 200 t of volatiles (~100 t water and ~100 t carbon-rich compounds), 90 t of metals (approximately 83 t of iron, 6 t of nickel, and 1 t of cobalt), and 200 t of silicate residue (similar to the average lunar surface material). As discussed below, the ACR mission concept baselines a single Atlas V 551-class launch, with an initial mass to low-Earth orbit (IMLEO) of 18,000 kg. The delivery of a 500-t asteroid to lunar orbit, therefore, represents a mass amplification factor of about 28-to-1. That is, whatever mass is launched to LEO, 28 times that mass would be delivered to high lunar orbit. Longer flight times, higher power SEP systems, or a target object in a particularly favorable orbit could increase the mass amplification factor from 28-to-1 to 70-to-1 or greater.

**Galactic Cosmic Rays:** Exposure to Galactic Cosmic Rays (GCRs) may represent a show-stopper for human exploration in deep space [10]. The only known solution is to provide sufficient radiation shielding mass. One of the potentially earliest uses of the returned asteroid material would be for radiation shielding against GCRs. Astronauts could cannibalize the asteroid for material to upgrade their deep space habitat with radiation shielding.

**Materials Extraction:** Aside from radiation shielding, initial processing work would concentrate on the extraction and purification of water. Human expeditions to the NEA in lunar orbit could collect and return significant quantities of material to the ISS where this initial processing work could be conducted in a micro-gravity environment. This would take advantage of the significant infrastructure represented by the ISS. The second level of processing should be the electrolysis of water into hydrogen and oxygen and the liquefaction of both gases. The third level of processing would involve strong “baking” to the point of forcing autoreduction of the major mineral magnetite ( $\text{Fe}_3\text{O}_4$ ) by the carbonaceous polymer, leading to total release of more water, carbon monoxide, carbon dioxide, and nitrogen. The fourth level of processing would entail using the released CO as a reagent for the extraction, separation, purification, and fabrication of iron and nickel products via the Mond (gaseous carbonyl) process [11]. The residue from Mond extraction of iron and nickel would be a dust of cobalt, platinum-group metals, and semiconductor components such as gallium, germanium, selenium, and tellurium. These challenges could be faced one at a time, not all at once.

Prototype-scale experiments on processing the materials in the retrieved asteroid would validate our concepts and refine our techniques for production of propellants, life-support materials, structural metals, and radiation shielding in support of large-scale autonomous space activities. The extraction of water from an NEO of asteroidal or cometary origin would provide us with propellants in space, at the site of future demand. The use of solar power for electrolysis of water could supply hydrogen and oxygen for chemical propulsion and oxygen for life support on manned deep-space missions. This could also provide fuel for the use in electrochemical cells.

A rough estimate based on NASA’s NLS-II agreement for launch services suggests that it costs about \$100K for each kilogram of mass delivered to a high lunar orbit using conventional chemical propulsion. Therefore, delivery of 500 t of material to a high lunar orbit would cost of order \$20B. As shown in Section VI, the cost of the first ACR mission including DDT&E plus the first unit, launch

services, mission operations, government insight/oversight, and reserves is estimated at \$2.6B. The first ACR mission would deliver asteroid material to high lunar orbit at a cost in \$/kg that would roughly be a factor of 8 cheaper than costs for launching that mass from the ground. The recurring cost for subsequent missions is estimated at approximately \$1B so subsequent missions would improve that cost savings to a factor of 20.

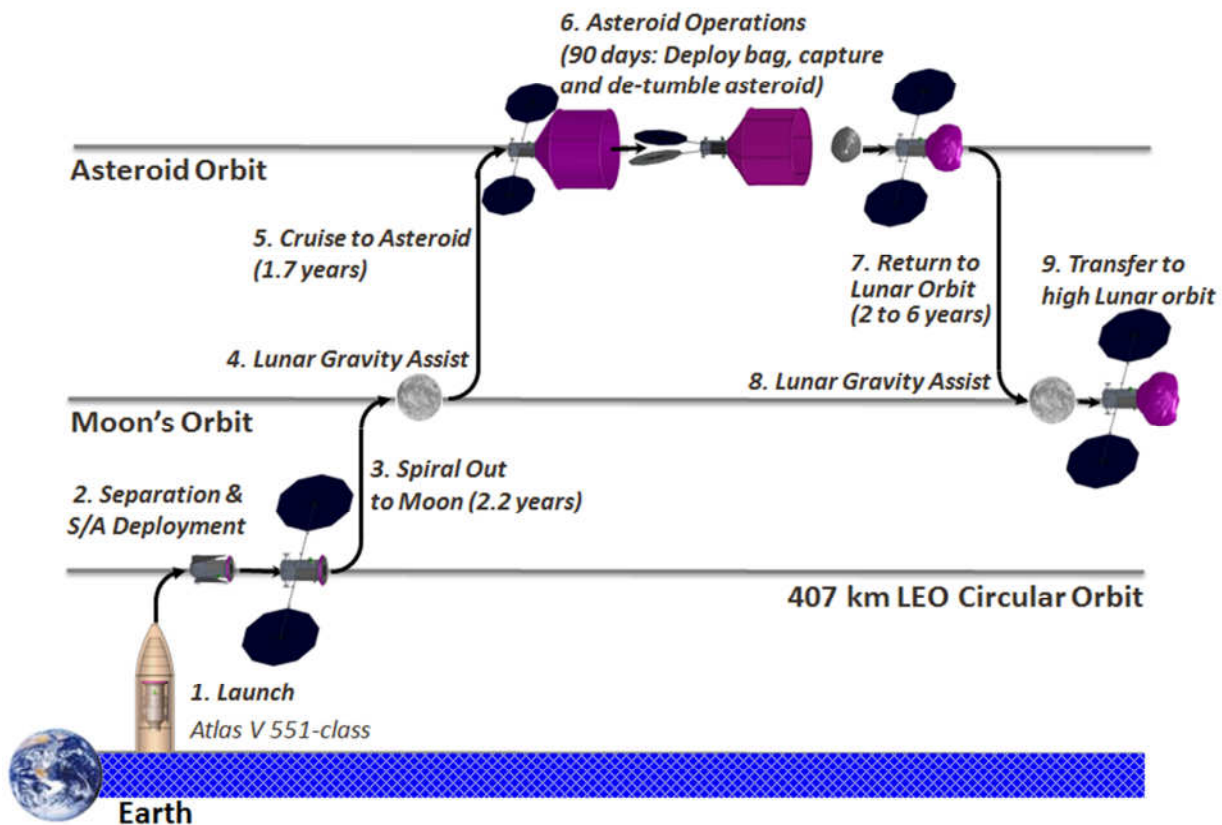
### **Public Engagement**

The excitement of changing the orbit and harnessing the resources of a celestial object for space exploration is obvious. A mission like this even decoupled from human exploration would engage a whole new generation of space interested persons, and coupled to the goal of enabling sending humans further than ever before in space it would inspire even more public interest. Beyond the excitement is the wide range of educational goals that would accompany this venture: knowledge of Earth's celestial environment, the engineering and mathematics of asteroid orbit modification, the science of solar system resources and the exploration into the solar system. Apollo was based on a cold-war rationale and ever since an over-arching geo-political rationale has been lacking from space ventures. Retrieving an asteroid for human exploration would provide a new purpose for global achievement and inspiration.

### III. MISSION OVERVIEW & SAFETY CONSIDERATIONS

A basic Asteroid Retrieval mission concept is illustrated in Fig. 1. The spacecraft would be launched on an Atlas 551-class launch vehicle to low-Earth orbit. A 40-kW electric propulsion system would then be used to reach the NEA in about 4 years. Once at the NEA, a 90-day operations phase is divided into two phases. During the first phase, the target would be studied thoroughly to understand its size, rotation, and surface topography. In the second phase the spacecraft would capture and de-spin the asteroid. To accomplish this, the spacecraft would match the target rotation, capture it using the capture mechanism described in Section VI, secure it firmly to the spacecraft, and propulsively despin the combination. The electric propulsion system would then be used to depart the asteroid orbit, return to the vicinity of the Moon, and enter a high-lunar orbit. After reaching lunar orbit the spacecraft would stay attached to support human activity, which is anticipated to include the development of NEA proximity operational techniques for human missions, along with the development of processes and systems for the exploitation of NEA resources.

The ACR spacecraft concept would have a dry mass of 5.5 t, and could store up to 13 t of Xe propellant. The spacecraft would use a spiral trajectory to raise its apogee from LEO to the Moon where a series of Lunar Gravity Assists (LGAs) would be used in concert with SEP thrusting to depart the Earth-Moon system. This initial leg of the trajectory would take from 1.6 to 2.2 years to reach Earth escape. From escape it would take roughly 2 years to reach the target asteroid. The return time would range from 2 to 6 years depending on the actual mass of the NEA. The concept system could return asteroids with masses in the range 250,000 kg to 1,300,000 kg, to account for uncertainties in size and density.



**Figure 1.** Asteroid return mission concept. Return flight time of 2 to 6 years depending on the asteroid mass.

## **Final Destination**

Since even small asteroids have relatively large masses – a 7-m diameter asteroid has a mass roughly equal to that of the ISS – the final placement of the asteroid in the vicinity of the Earth must be considered carefully. Although the very low strength of a type C asteroid would minimize the likelihood that entry of such a body might inflict damage on Earth’s surface, it would be more prudent to place the retrieved asteroid in an orbit from which, if all else fails, it would only impact the Moon, not Earth. Lunar orbit or possibly regions near the Earth-Moon Lagrange points would, therefore, be preferred for this criterion. The second factor regarding the choice of a “parking place” is that it is important to place the asteroid in a location that is reasonably close to and accessible from Earth (within a few days journey from LEO). A third factor is the desire to park the asteroid in a place at which there is some foreseeable future demand for water and water-derived propellants, so that production of useful materials could serve the needs of future space missions. This third factor suggests LEO and the lunar vicinity as the best choices. These three factors combined suggest the immediate vicinity of the Moon as a reasonable choice. Whatever the final destination the mission must clearly define the end-of-mission conditions and asteroid maintenance and disposal effort (e.g., lunar surface). For the purposes of the trajectory design described later, we assumed a high lunar orbit as the destination for the returned asteroid.

## **Safety**

The first question that must be answered in the consideration of feasibility is, “could the mission be conducted safely?” In fact, moving a non-hazardous asteroid toward the Earth must not just be safe, but it must be completely perceived as safe to an interested, and likely concerned, public. Safety would have to be guaranteed by the mission design. This subject was addressed in our workshops and resulted in the following “belt & suspenders” approach to safety.

First, the size and mass of the asteroid to be returned would be like many other meteorites which routinely impact the Earth and burn up harmlessly in the atmosphere. Moving an asteroid of sufficiently small size would not add to the danger from small meteorites, which are small pieces of asteroids that approach Earth.

Second, we are selecting a carbonaceous asteroid. Asteroids of this type and size are known to be too weak to survive entry through the Earth’s atmosphere, so then even if it did approach the Earth it would break up and volatilize in the atmosphere.

Thirdly the trajectory design for moving the asteroid toward the Earth would keep it on a non-impact trajectory at all times. Therefore, if the flight system fails the resulting orbit would be no more dangerous than that of thousands of natural and man-made objects in near-Earth space.

Fourth, the destination orbit would be a high lunar orbit so that even at the end of mission the natural perturbations of the trajectory would cause an eventual impact on the Moon, not on Earth. This can be insured by the laws of celestial mechanics and selection of orbit. Although multiple levels of redundancy would be employed to maintain control of the asteroid, in the event of a failure in which control is lost the asteroid would also impact the Moon.

With these levels of safety – all of which will be further analyzed and assessed during the phase II study – we can conclude the mission could be safe and that it could be explained convincingly to the public. Furthermore, this mission would help make it safe for humans to go on longer voyages beyond the Moon. Sending a human to a Near-Earth Asteroid now would require months of flight time and consequent life support and radiation protection systems not yet designed. Additionally, operations at a NEA in its natural orbit would be conducted months away from any return to Earth. By exercising the NEA mission at a chosen location in cislunar space, we would take that first step beyond the Moon safely, and build up the knowledge and capability for further steps. Metaphorically, we would be dipping our toe into the vast ocean of space before taking our first real plunge.

## IV. TARGET DISCOVERY AND CHARACTERIZATION

### Asteroid Type

The most desirable asteroids for return are the carbonaceous C-type asteroids that are deemed by the astronomy community to have a planetary protection categorization of unrestricted Earth return. Carbonaceous asteroids are the most compositionally diverse asteroids and contain a rich mixture of volatiles, complex organic molecules, dry rock, and metals. They make up about 20% of the known population, but since their albedo is low, they may be heavily biased against detection in optical surveys. Retrieving such asteroid material would enable the development of as many extraction processes as possible. Carbonaceous asteroid material similar to the CI chondrites is easy to cut or crush because of its low mechanical strength, and can yield as much as 40% by mass of extractable volatiles, roughly equal parts water and carbon-bearing compounds. The residue after volatile extraction is about 30% native metal alloy similar to iron meteorites [12].

Our first priority, then, is to locate several, accessible ~7-m carbonaceous-chondrite objects which could be returned to Earth at some point in the 2020's. This requires a dramatic increase in the discovery rate of small asteroids. Such an increase is possible with relatively minor adjustments to current survey programs.

**Synodic Period Constraint** – The feasibility of returning an entire (small, 7-m) asteroid hinges mainly on the question of how to find sufficiently small asteroids that have orbital parameters extremely close to Earth and yet will return soon enough to be of interest. Small asteroids can only be discovered by ground-based observatories when they make a very close approach to Earth, where their intrinsic faintness is overcome by extreme closeness to the observer. In order to be able to return these objects to the vicinity of the Earth they must have orbital parameters that are very similar to Earth's. Consequently these objects will have synodic periods that are typically one or more decades long. This places an additional constraint on small asteroids in order to be candidates for return. They must have synodic periods of approximately one decade. This would enable the object to be discovered and characterized followed by a mission targeted to return the NEA by the next close approach approximately 10 years later. There is an existence proof that such objects exist. The asteroid 2008HU4 is estimated to be roughly 8-m in diameter and will make its next close approach to Earth in 2016 with a subsequent close approach in 2026. Trajectory analysis presented in Section VI assumes this target asteroid and demonstrates how it could be returned to the vicinity of the Earth by 2026 using a 40-kW solar electric propulsion (SEP) system.

### Discovery and Characterization Techniques

Discovery and characterization of a sufficient number of candidate NEAs suitable for return is critical. Multiple good targets with launch dates covering multiple years around the nominal launch date would be required to develop a robust mission implementation plan. To support mission planning it would be necessary for each candidate target asteroid that its orbit be adequately known and have the right characteristics, that it be a volatile-rich, C-type asteroid, and that it have the right size, shape, spin state and mass, and that the values of these parameters be known with uncertainties that make the flight system design practical. The current best size frequency distributions for near-Earth asteroids suggest that there are roughly a hundred million NEAs approximately 7-m diameter, but only a few dozen of these are currently known. Fewer still have secure orbits and none of them have known spectral types. It is expected that a low-cost, ground-based observation campaign could identify approximately five good candidates per year that meet these requirements out of roughly 3,500 new discoveries per year.

The key to the discovery and characterization campaign is to determine the minimum asteroid size that enables a target discovery and characterization rate sufficient to provide an adequate number of candidate asteroids before the end of this decade, and around which a mission could be planned. Larger asteroids are easier to discover and characterize but much harder to move. Since the volume and mass



scale as the cube of the diameter, but the projected area scales as the square of the diameter, smaller asteroids get less massive much faster than they get dimmer. The key feasibility issue is to determine if there is an overlap between NEAs that are bright enough (i.e, large enough) to be discovered and characterized and small enough to be moved with near-term SEP propulsion capability.

Periodic comets and asteroids that reach a perihelion distance of 1.3 Astronomical Units (AU) or less are defined as near-Earth objects (NEOs). The vast majority of these NEOs are near-Earth asteroids (NEAs) and roughly 20% of the NEA population have orbits that come within 0.05 AU of the Earth's orbit [13]. It is the population of NEAs with Earth-similar orbits that are both the most likely to strike Earth naturally and would be the most easily accessible for spacecraft round-trip missions.

The densities of asteroids vary widely, from  $\sim 1 \text{ g/cm}^3$  for a high-porosity carbonaceous chondrite to  $\sim 8 \text{ g/cm}^3$  for solid nickel-iron meteorites. The majority of NEAs have densities between  $1.9 \text{ g/cm}^3$  and  $3.8 \text{ g/cm}^3$  [14]. The mass of an asteroid as a function of its diameter (assuming spherical asteroids) is given in Table 1 over the range of densities from  $1.9 \text{ g/cm}^3$  to  $3.8 \text{ g/cm}^3$ . This table indicates that even very small asteroids can be quite massive from the standpoint of transporting them to the vicinity of the Earth. For example, a 7-m diameter asteroid with a density of  $2.8 \text{ g/cm}^3$  has a mass of order 500,000 kg. Small asteroids are not spherical, but Table 1 gives a general sense of the masses of these small objects.

**Table 1.** Asteroid Mass Scaling (for spherical asteroids)

<b>Diameter (m)</b>	<b>Asteroid Mass (kg)</b>		
	<b>1.9 g/cm<sup>3</sup></b>	<b>2.8 g/cm<sup>3</sup></b>	<b>3.8 g/cm<sup>3</sup></b>
2.0	7,959	11,729	15,917
2.5	15,544	22,907	31,089
3.0	26,861	39,584	53,721
3.5	42,654	62,858	85,307
4.0	63,670	93,829	127,339
4.5	90,655	133,596	181,309
5.0	124,355	183,260	248,709
5.5	165,516	243,918	331,032
6.0	214,885	316,673	429,770
6.5	273,207	402,621	546,415
7.0	341,229	502,864	682,459
7.5	419,697	618,501	839,394
8.0	509,357	750,631	1,018,714
8.5	610,955	900,354	1,221,909
9.0	725,237	1,068,770	1,450,473
9.5	852,949	1,256,977	1,705,898
10.0	994,838	1,466,077	1,989,675

For NEAs with diameters larger than 100 meters, the size-frequency distribution has recently been revised downwards as a result of the WISE space-based infrared observations that were made throughout 2010 and for two months into 2011 [15]. At the small end of the NEA size-frequency distribution, there are roughly 20,500 NEAs larger than 100 meters with about 25% discovered to date, but for the smallest members of the NEA population, there are millions of NEAs larger than 10 meters and billions of NEAs larger than 2 meters. However, far less than one percent of these populations have been discovered. The difficulty is that small NEAs are faint and discoverable with the current one-meter class ground-based telescopes only when they make very close Earth approaches. For example, with an assumed albedo of 25%, a 2-m-sized asteroid 0.005 AU from the Earth would have an apparent magnitude of about 31. There are only four discovered objects of this size and all are currently lost and

would have to be re-discovered. There are, however, 300 asteroids approximately 10-m diameter discovered to date but only a few of these currently have secure orbits, and even fewer have the physical characterization that would allow them to be identified as a particular spectral class or have information on their albedos or true diameters.

By far the most efficient NEO search program to date is the Catalina Sky Survey (CSS) near Tucson Arizona [16]. When comparing the efficiencies of NEO search telescopes, the metric of choice, called the “entendue” is the product of the telescope’s aperture and its field of view. For the CSS, its entendue is about 2. Next generation NEO search telescopes include the Panoramic Survey Telescope and Rapid Response System 1 (Pan STARRS 1) on Haleakala in Maui Hawaii, which should reach an entendue of about 13 when fully operational [17]. In addition there are plans for PanSTARRS 4, a set of four, co-located PanSTARRS 1 telescopes, which should have an entendue of about 51. The Large Synoptic Survey Telescope (LSST), which is a 8.4 meter aperture, wide field telescope in Chile, has plans for first light in 2018 [18]. The entendue for LSST is about 320 so it could be about 150 times more efficient at finding PHAs than the current CSS system.

When first discovered, all that is known about near-Earth asteroids are their orbits and their absolute magnitudes. An object's absolute magnitude can be converted to its size if its albedo is known. However, the albedos of near-Earth asteroids vary widely. Most (but not all) NEAs have albedos between 0.09 and 0.36 [19], which means that an asteroid's diameter can only be estimated to within about a factor of two from its absolute magnitude. The object's volume then can only be quantified to within a factor of 8 or 10. Assuming a factor of 2 uncertainty in the density then results in a factor of 20 uncertainty in the estimated mass of a NEA without any information beyond the discovery magnitude – and there will be significant outliers beyond even that range.

The asteroid’s mass can be estimated more accurately with additional data. If we consider ~10-m-class objects that are discovered during one Earth flyby as potential mission targets during their next Earth flyby, follow-up observations must occur as soon as possible after a potential target is discovered. Ideally follow-up should start within a day and must be started within a week.

The first follow-up observation should be additional optical astrometry to better determine the NEA’s trajectory and ensure that it will not be lost – although at this point our knowledge of its orbit would not be sufficient for a spacecraft rendezvous many years in the future. Such astrometry of newly discovered NEAs is routinely and very reliably provided by a worldwide network of professional and amateur astronomers, as demonstrated by the case of 2008 TC3 in which 26 observatories observed that object within 19 hours of its discovery [20].

The other necessary follow-up observations can occur in any order or simultaneously. Optical lightcurve measurements will likely tell us the object’s spin rate and if it is in a tumbling non-principal-axis rotation state or not [21]. More importantly for estimating the object’s mass, optical and near-infrared spectroscopy (which require the attention of professional astronomers) will constrain the asteroid’s composition – particularly to determine if it is rich in silicates (an S-class object) or in carbonaceous material (a C-class object) [22]. While asteroid’s densities can vary significantly even given the same composition, due to differences in porosity, that variation is ~50% rather than the wider range of the whole population [23].

Spectral classifications are often made solely on the basis of optical and near-IR colors. This is not sufficient for our purposes: meteorites that have C-class colors have a wide range of compositions, and only some are the water- and organic-rich carbonaceous chondrites that are normally considered to define the C-class. High-sensitivity spectroscopy covering the optical and near-IR (0.5 – 3.5 microns) is desirable to detect the absorption bands at ~0.7 and ~3.0 micron that unambiguously indicate a carbonaceous chondrite composition [24].

Thermal infrared flux measurements allow us to estimate an object’s albedo, limited by the object’s shape, thermal properties, and brightness. For large objects (>100 m), we can often obtain sizes accurate to ~10-20% from thermal radiometry [25]. However, for small objects with more irregular shapes,

estimates of their dimensions are only accurate to ~30-40% [26].

The final type of follow-up is radar ranging measurements. Currently, the Goldstone Solar System Radar can image asteroids with resolution as fine as 3.75 m [27]. This allows us to determine the target's trajectory well enough for a later rendezvous and to measure its dimensions to ~40% for a 10-m object. For a rapidly rotating target with a known spin state, we can estimate the size somewhat more accurately by measuring the Doppler bandwidth of the radar echoes, caused by the relative motion between one side of the object and the other. Radar shape and spin state modeling works best in combination with optical lightcurve observations, with the radar imaging providing spatial resolution and the lightcurves providing a more accurate measurement of the object's spin rate.

Radar ranging measurements also provide very accurate astrometry, sufficient for rendezvous with the object many years later [28]. With optical astrometry only, at least two epochs of observation separated by several years are required to obtain a similarly reliable orbit solution. With radar imaging, we can obtain a ~10-m NEA's dimensions to within  $\leq 40\%$ , and its volume to within a factor of 2.75. With composition information, this gives an uncertainty in the asteroid's mass of a factor of 4 for most objects.

In a few cases, we can obtain asteroid's masses more accurately still. Approximately one-sixth of near-Earth asteroids larger than 200 m are binaries, and measurements of the mutual orbit of a binary system with radar allows us to determine the mass of the system, and in some cases the mass ratio of the components, to within a few percent [29]. However, those objects are likely too large to be moved - the smallest known asteroid satellite is ~60 m in diameter - and the fractional mass uncertainty becomes quite large for small satellites around large primary objects.

If radar ranging or high-precision optical astrometry of a ~10 m object can be obtained three or more times over a time span of months to years, we can measure the perturbations to its orbit due to radiation pressure, either direct solar radiation or the asteroid's thermal emission (the Yarkovsky effect) [30,31]. The asteroid's acceleration indicates its mass loading, so that we can estimate its mass to within 50%. Without three or more epochs of observation separated sufficiently in time, we cannot separate the effects of radiation pressure from other sources of uncertainty in the target's trajectory. For small objects that can be observed only during close Earth flybys it will not be possible to make these observations before we would want to launch this proposed mission.

## Observation Campaign

Based on the rough estimates of the number of small asteroids that are available [32,33], the average sky density of asteroids with diameters between 7 and 30 m and apparent R-band magnitude  $< 18$  at any given moment is  $\sim 1/(70 \text{ deg}^2)$ . Most of these objects will be  $> 0.01 \text{ AU}$  and  $< 0.03 \text{ AU}$  away, and moving at  $\sim 1^\circ/\text{hour}$ . In addition to these objects, there will be a comparable number of 30 to 90 m objects at distances up to 0.1 AU, moving at  $\sim 20'/\text{hour}$ .

We have considered the cases of two existing surveys. For the Palomar Transient Factory (PTF) [34], which is currently observing a total of 400 to 640  $\text{deg}^2/\text{night}$  with 20 min cadence, there will be 3 to 5 such asteroids each night that are seen as  $\sim 1'$  streaks in the same field in two successive images<sup>1</sup>. 18 mag is a reasonable number for PTF's detection limit for such streaks, but the limiting brightness and so the number of detectable objects will depend significantly on weather. For CSS, a limiting magnitude 16.5 for streaks and sky coverage 1200  $\text{deg}^2/\text{night}$  implies that 2 to 3 fast-moving asteroids will be visible each night. If Pan-STARRS can also observe a total of 400 to 640  $\text{deg}^2/\text{night}$ , then the number of detectable fast-moving asteroids will be comparable to PTF. Consequently, the total number of fast-moving small objects that could potentially be located by these three surveys each night is between 8 and 13. We assume 10 in the estimates below.

<sup>1</sup> There will be 2-4 asteroids that are seen in one image but have moved out of the field by the next one. Objects much smaller than 7 m will only be detectable when they are much closer than 0.01 AU and moving so quickly that the loss fraction more than offsets their increased number. We have not considered linking streaks in images of one field to streaks in images of an adjacent one.

**Locating the fast-moving objects** – In order to be useful, detections of these objects must be announced within a few hours, so that follow-up telescopes in North America and Hawaii, but also Asia and Australia, can observe them before they are lost. For PTF this could be accomplished as follows: Currently, images are processed as they are taken by subtracting the reference images from them and flagging any remaining point sources. To avoid excessive downlink data rates a copy of the subtracted images could be sent to a new PTF computer, to flag streaks with the appropriate combination of length and brightness and link them together to provide a track of the asteroid’s motion over the next several hours. The relevant images (a very small fraction of the total data) would then be transmitted from the PTF. Depending on what levels of false positives and false negatives are acceptable, the follow-up telescopes can be notified automatically with the sky track and predicted positions for the object or the detected streaks can be reviewed by a human before sending a request.

**Follow-up Observations** – The discoveries would need to be followed-up by additional optical astrometry, and all astrometry provided to the Minor Planet Center, within a few hours. The existing community of asteroid observers can follow-up a certain number of objects on such timescales automatically, but ~10 per night may be too much and purchasing dedicated robotic telescope time for this purpose will likely be required.

After the first round of follow-up astrometry, we would begin culling the objects to locate those that we are interested in (Table 2). The first round of culls would really take place at discovery, when we impose cuts in apparent magnitude and plane-of-sky motion to focus on only fast-moving small objects. The second cull would be to use the asteroids’ orbital elements to exclude objects with  $C3 > 20 \text{ km}^2/\text{s}^2$ , which comprises ~95% of the discoveries. These would not be suitable for returning to Earth. Astrometry on the remaining objects should continue for at least the next two days, jointly with additional follow-up.

**Table 2.** Target Rates at Different Stages of Follow-Up Observations

<b>Time Since Discovery</b>	<b>Rate (#/day)</b>	<b>Rate (#/year)</b>	<b>Stage of Follow-Up</b>
≤ 12 hrs	10	3,600	Astrometry
≤ 24 hrs	0.5	180	Astrometry, colors
≤ 48 hrs	0.2	70	Lightcurves
≤ 48 hrs	0.1	36	Spectroscopy
≤ 72 hrs	0.06	20	Radar
<b>Net Rate of Target Discovery</b>	<b>0.013</b>	<b>5</b>	

The next stage of follow-up would be to obtain photometry. We want a water-rich carbonaceous chondrite object as the target of this mission. Such asteroids are C-class objects, with slightly reddish spectra in the visible and near-IR, and absorption bands associated with water at 3 microns and 0.7 microns. Broad-band colors do not give an estimate of the water content, but allow us to distinguish silicate and metallic objects from the C-classes. We would want colors on roughly one object every two days, which can be done by current asteroid observers, both professional and amateur, using small (<0.5 m) telescopes. Colors would exclude roughly 60% of objects as not having suitable composition.

After or simultaneously with obtaining colors, we would want lightcurve observations to determine the asteroids’ spin rates. If the mission design is limited to objects spinning no more rapidly than once every 10 minutes, roughly half of the objects would be excluded due to spinning too fast. Lightcurve observations would require 1-2 m telescopes that could be scheduled on short notice, such as the Magdalena Ridge Observatory, ideally a couple of hours of observation on each target on two successive nights to obtain good values for the spin rates and check for non-principal-axis rotation.

After culling the targets based on lightcurves and colors, we would be left with ~1% of the initial

discoveries, about one per ten nights. The next cull would be spectroscopy with ~1 m optical telescopes, separating those C-types that have abundant water from those that do not, another 40% or 50% decrease in the target rate. We can do this using an absorption band at 0.7 microns. This band is not due to water itself, but due to charge transfer in iron-bearing minerals that occur only in C-type objects when water is also present [35,36]. There is a more direct way of detecting water, by looking for a vibrational transition at 3 microns. However, these targets would be too faint to detect at 3 microns because of the very high background emission from the atmosphere in the mid-infrared. The presence of the 0.7 micron feature does not let us precisely estimate the water content of an object, but it must be greater than a few percent (and may be as high as 30%).

The final follow-up observations would be radar observations, to determine the target's sizes and approximate densities, refine knowledge of their spin states, and improve our knowledge of their orbits to the point that a spacecraft rendezvous would be possible. Such observations would require a few hours of time with the Goldstone and/or Arecibo radars once per two or three weeks, scheduled within about 72 hours of discovery. This is within the current observing rate at both telescopes. However, as a caution, many observations on short notice at Goldstone would require changes in how transmit time is assigned there, and we may run into limits due to conflicts with scheduled deep-space telecom at Goldstone and other time-sensitive projects at Arecibo.

After the radar observations, we would have size and mass estimates and trajectory knowledge sufficient to understand which objects are in fact attractive targets, with the lowest C3s and convenient future close approaches. This would decrease the target rate by a further factor of four, assuming that the best targets would have  $C3 < 6$ , *giving us a final mission target discovery rate of about 5 per year*. This estimate is promising, but the entire sequence of discovery and characterization will need refining before the surveys can commence

### **Alternative Approach**

The discovery of larger objects ( $\geq 100$  m) is, of course, much easier than those less than 10-m in diameter. These objects can be seen at >10X greater range, so much more accurate orbits can be determined with a single pass by Earth. They are visible for enough successive nights that spectroscopic and/or radar observations can be easily arranged. Almost all NEAs whose spectral types are known fall in this category.

Only a few NEAs, all >100-m diameter, have been approached sufficiently closely to get high-resolution images of their surfaces. All such objects appear to have discrete rocks ranging from gravel to house-sized boulders (and larger) on their surfaces. Analyses of spin periods indicate that larger objects have spin periods generally longer than ~2 hours, the "rubble pile limit". Objects with periods slower than this limit have self-gravity at the equator greater than the centrifugal force that would fling loose objects off into space. Objects spinning faster than this are presumed to be competent rock or otherwise coherent and cohesive objects, since the centrifugal force is larger (often much larger) than gravity at the equator. Studies of spin periods show that small objects, with few exceptions, spin faster than the rubble pile limit, while larger objects, again with few exceptions, spin slower than the rubble pile limit. This suggests that larger objects are rubble piles, with a range of sizes of loose material on their surfaces.

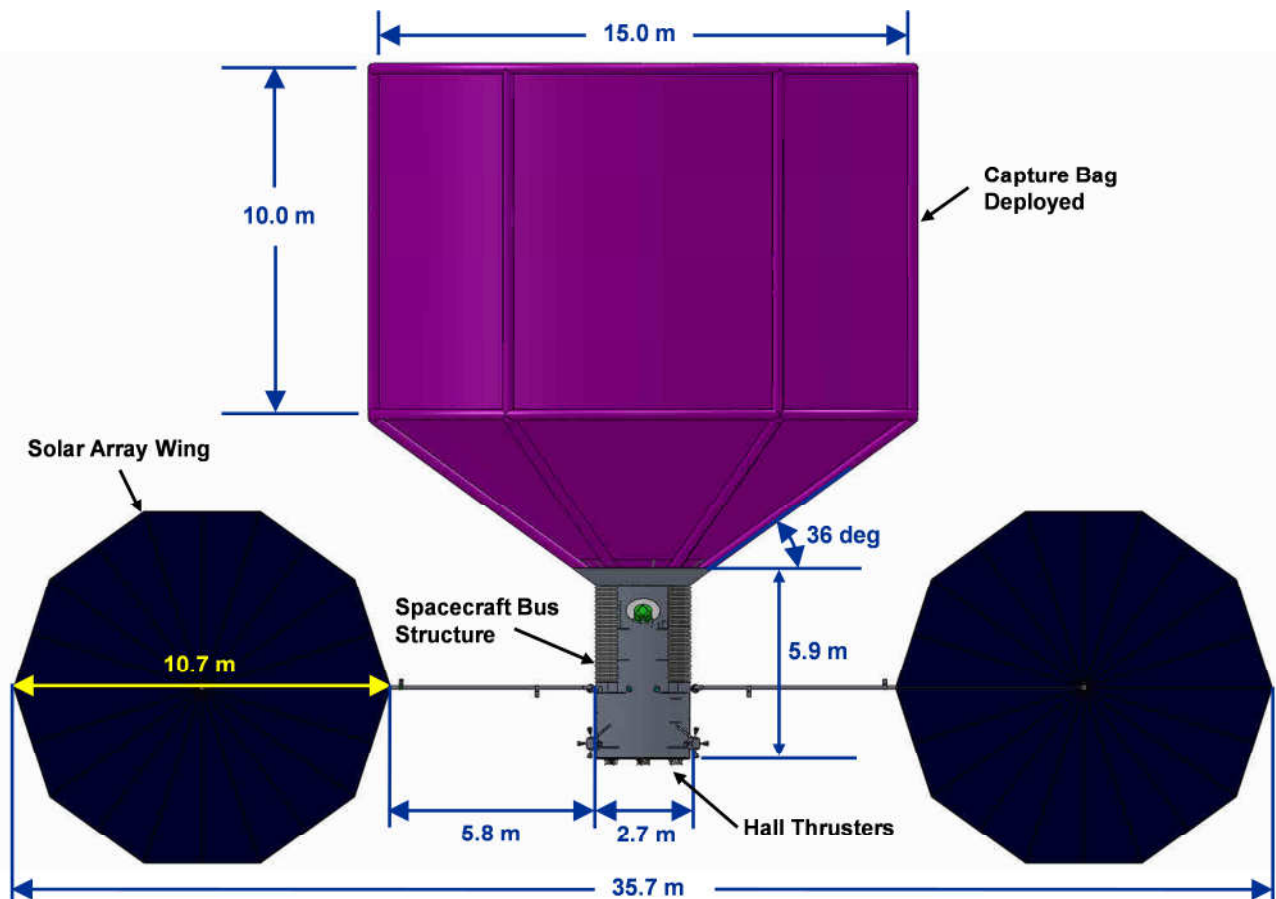
So the alternative approach would be to target a larger NEA, knowing that the entire object is far too massive to return intact and assume that we could take a 7-m piece off it. We'll refer to this alternative tactic as the *Pick Up a Rock* approach. The approach to capturing and returning an entire small NEA we'll refer to as *Get a Whole One*, when it is necessary to distinguish it from the *Pick Up a Rock* approach. For the *Pick Up a Rock* scenario, in the unlikely event that a single right-sized piece could not be found, then at the very least the system could be designed to collect enough regolith or many small pieces to approach the design-capacity of the system in terms of return mass (i.e., a few hundred metric tons).

## V. FLIGHT SYSTEM DESIGN

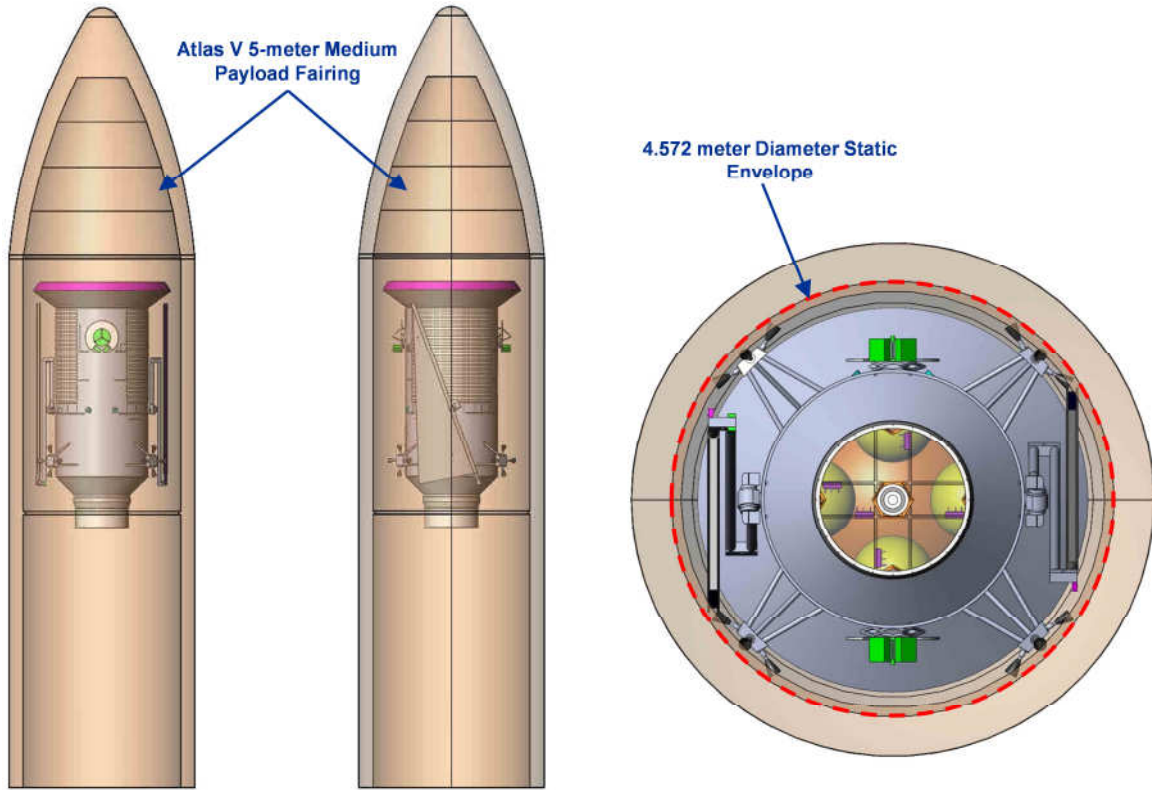
A conceptual design of the flight system was developed by the COMPASS team at NASA GRC based on guidance provided by the KISS study team. The flight system in the cruise configuration is given in Figs. 3 through 6. The spacecraft configuration is dominated by two large solar array wings that would be used to generate at least 40-kW of power for the electric propulsion system (end-of-life at 1 AU) and the large inflatable structure of the capture mechanism. The solar arrays are sized to accommodate up to 20% degradation due to spiraling through the Earth's radiation belts. A margin of 9% is assumed to be added to the 40-kW power level and 1,200 W is allocated for the rest of the spacecraft. The solar array is assumed to be configured in two wings with each wing having a total area of approximately 90 m<sup>2</sup>. There are multiple candidate solar array technologies that would have the potential to meet the needs of this proposed mission. For example, solar array wings based on the Ultraflex [37] design are shown in Fig. 3. The spacecraft is shown in the stowed configuration in Fig. 4. Key spacecraft subsystems are described below.

### Electric Propulsion (EP) Subsystem

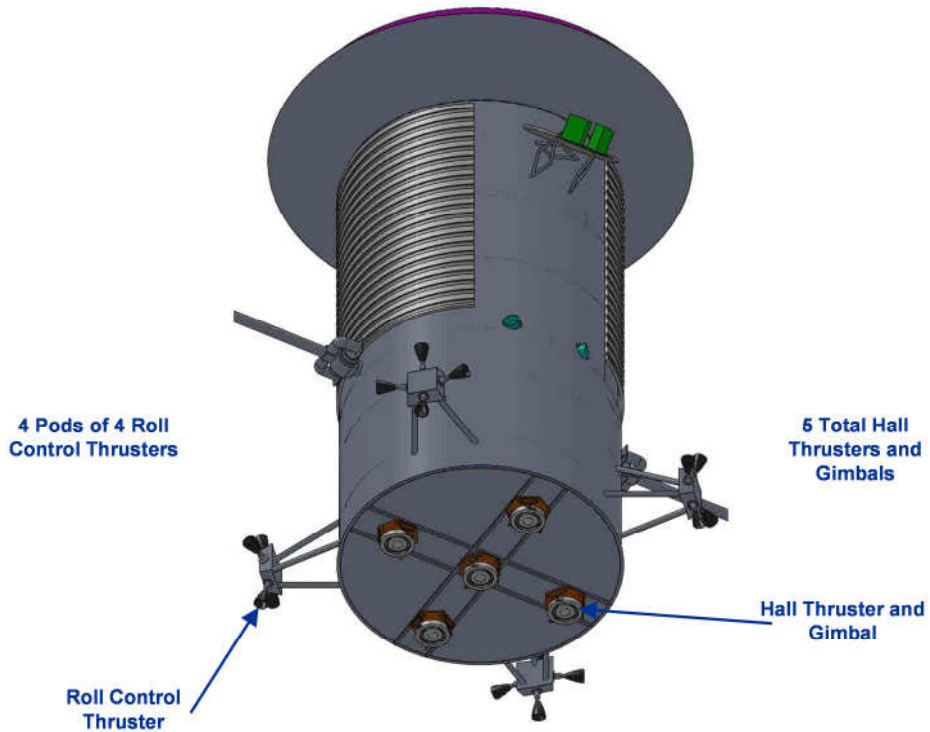
The EP subsystem concept includes a total of five 10-kW Hall thrusters and Power Processor Units (PPUs). A maximum of 4 thruster/PPU strings are operated at a time. It also includes xenon propellant tanks, a propellant management assembly, and 2-axis gimbals for each Hall thruster. The electric propulsion subsystem concept incorporates one spare thruster/gimbal/PPU/XFC string to be single fault tolerant.



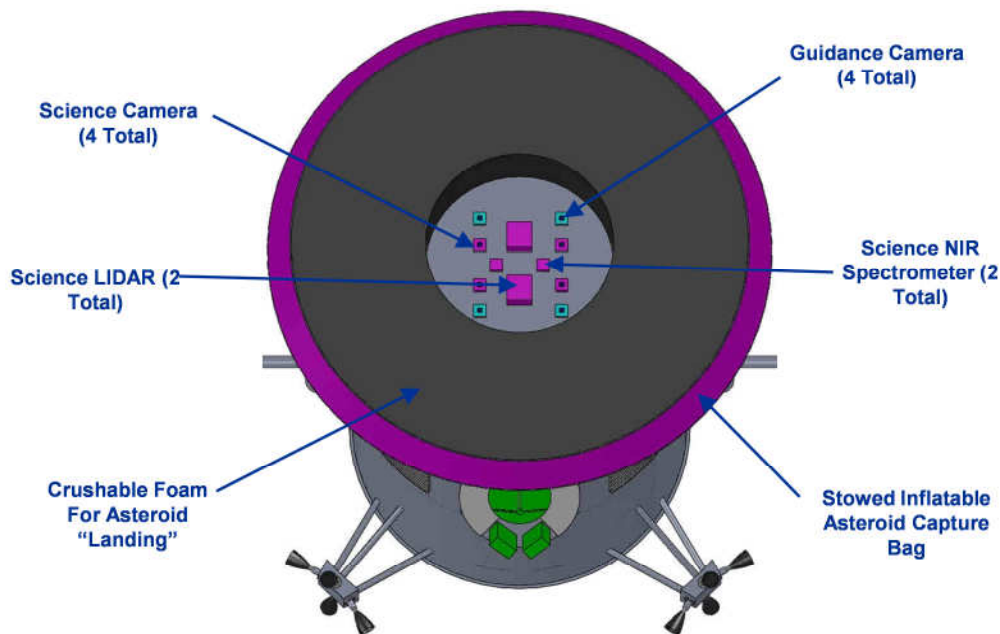
**Figure 3.** Conceptual spacecraft in the cruise configuration with the capture mechanism deployed.



**Figure 4.** Conceptual ACR spacecraft in the stowed configuration.



**Figure 5.** Bottom view of the conceptual ACR spacecraft showing the five 10-kW Hall thrusters and the RCS thruster clusters.



**Figure 6.** Top view of the conceptual ACR spacecraft showing the instrument suite and capture mechanism prior to being deployed.

Each thruster is estimated to have a mass of 19 kg, and would operate at a specific impulse of up to 3,000 s at a PPU input power level of ~10 kW. The xenon propellant tank design is based on a cylindrical, composite overwrap pressure vessel (COPV) design with a seamless aluminum liner. Such tanks are projected to have a tankage fraction for xenon of approximately 4%. (For reference, the Dawn xenon tank had a tankage fraction of 5%.) A total of seven xenon tanks would be needed to store the 12,000 kg of xenon required for this mission. Each tank would have a diameter of 650 mm and would be approximately 3,500 mm long.

Attitude control during SEP thrusting would be provided by gimbaling the Hall thrusters. This would provide pitch, yaw, and roll control for the spacecraft. Thrusting with the electric propulsion system would be the normal operating mode for the spacecraft, i.e., this is the mode in which the spacecraft would spend the vast majority of its time during the mission. At other times attitude control and spacecraft translation would be provided by a monopropellant hydrazine reaction control system.

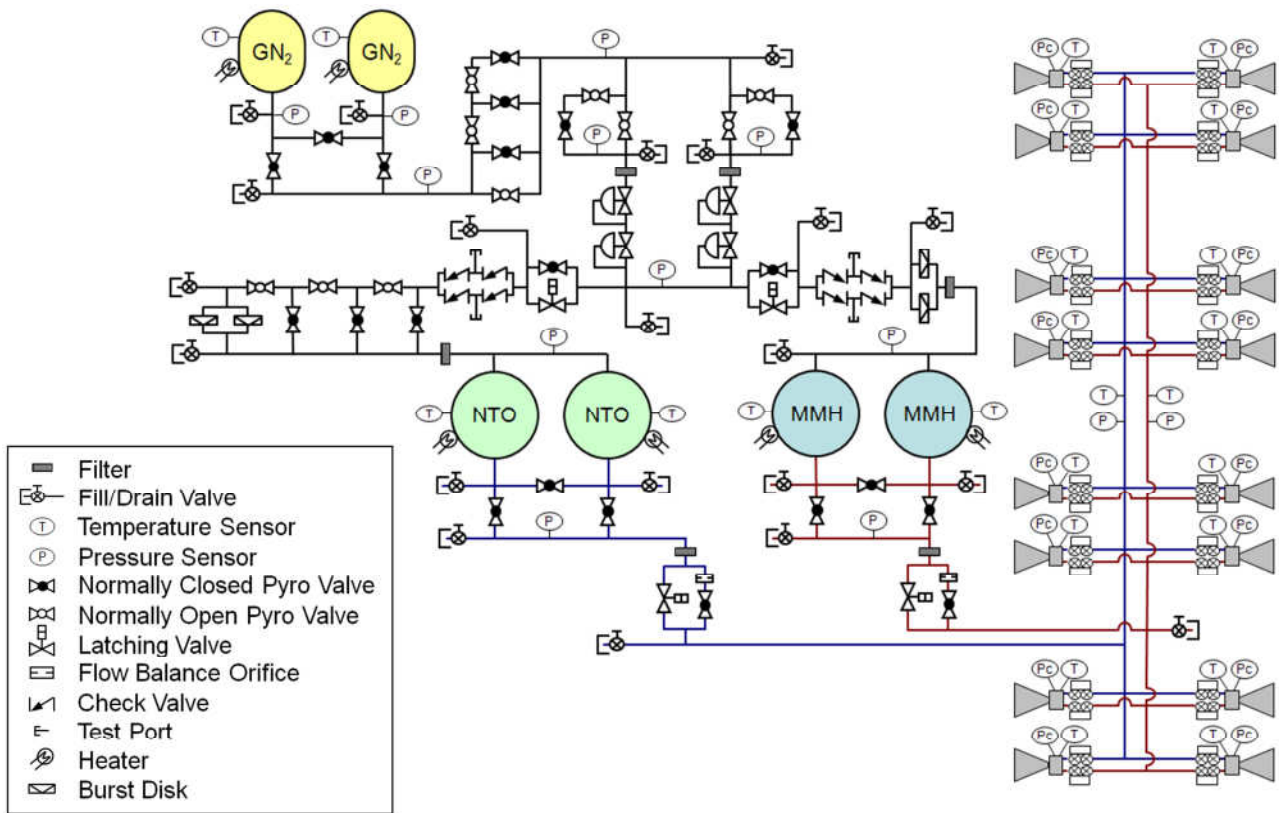
### **Reaction Control Subsystem (RCS)**

The RCS concept is a single fault tolerant, hypergolic bipropellant subsystem using monomethylhydrazine (MMH) and nitrogen tetroxide (NTO) with a gaseous nitrogen pressurization system. It includes four pods of four thrusters as indicated in Fig. 5. Each thruster has a nominal thrust of 200 N and a specific impulse of 287 s. A preliminary schematic of the RCS concept design is shown in Fig. 7. The RSC could store up to 900 kg of propellant. The propellant required to de-tumble the asteroid was estimated to be about 300 kg. A margin of 50% is added to this along with an estimated 200 kg of propellant to control the spacecraft before and after capture for a total requirement of 650 kg. Adding addition margin brings the total estimated RCS propellant load to 900 kg.

### **Electrical Power Subsystem (EPS)**

The power system design is sized to provide 41.2 kW at 120 VDC to the user input at EOL. It would use two 10.7-m diameter Ultraflex solar arrays with 33% efficient, advanced Inverted Metamorphic





**Figure 7.** Reaction Control Subsystem (RCS) schematic.

(IMM) solar cells and 20-mil coverglass on front and back sides. The solar arrays could be canted toward the aft portion of the vehicle during asteroid capture and would be off-pointed at most 85° and provide at least 3.6 kW.

A secondary lithium ion battery would provide 392 W-hr at up to 15% DOD. Up to 1954 W-hr available at 20°C and 80% DOD. The 120 VDC power from solar array would be down-converted to 28 VDC for use by the rest of the spacecraft (non-EP) loads.

### Communications Subsystem

Since the asteroid's orbit would be by selection similar to Earth's, the maximum communication distance would be ~ 2 AU. Communication to DSN 34 meter sites at Ka-band and X-band would be needed before, during, and after the capture of the asteroid. The upper limit on the spin rate of the asteroid is 1 revolution per minute or 6 degrees per second. The asteroid capture process is assumed to take 2 hours with no interactive feedback loop with Earth. The process to de-spin is assumed to take an additional 45 minutes.

The high initial possible spin rate of 6 degrees per second of the asteroid makes the communication difficult. Normally antennas can track a target while communication with a spin rate of 2 degrees per second. Also, the antenna must be able to rotate continuously in both axes. This resulted in the preliminary selection of phased array antennas although this trade will be re-evaluated in future studies.

An X-band capability is included in the design for safe mode communication. This capability is based on a 200-W X-band system with omnidirectional antennas, and would provide a minimum data rate of 20 bps from the spacecraft to Earth.

### Master Equipment List (MEL)

A preliminary MEL for the Asteroid Capture and Return flight system concept is given in Table 3.

This MEL indicates a maximum expected wet mass of 15,500 kg, which is 3,300 kg less than the 18,800 kg launch vehicle capability to LEO.

**Table 3. Asteroid Capture and Return Conceptual Spacecraft MEL.**

WBS Number	Description FETCH - October 2011 (CD-2011-67)	QTY	Unit Mass	Basic Mass	Growth	Growth	Predicted Mass
			(kg)	(kg)	(%)	(kg)	(kg)
06	<b>FETCH - Asteroid Return Spacecraft</b>			15027.6		511.6	15539.2
06.1	<b>FETCH - Spacecraft Bus</b>			15027.6		511.6	15539.2
06.1.1	<b>Payloads</b>			339.0	20.0%	67.8	406.8
06.1.1.a	Main Instruments			339.0	20.0%	67.8	406.8
06.1.2	<b>Avionics</b>			60.9	23.5%	14.3	75.2
06.1.2.a	Command & Data Handling (C&DH)			49.9	22.4%	11.2	61.1
06.1.2.b	Instrumentation & Wiring			11.0	28.2%	3.1	14.1
06.1.3	<b>Communications and Tracking</b>			61.8	24.4%	15.1	76.9
06.1.3.a	Ka-band Reflect Array			46.5	22.5%	10.5	57.0
06.1.3.d	X-band command and safing system			15.3	30.0%	4.6	19.9
06.1.4	<b>Guidance, Navigation, and Control (GN&amp;C)</b>			20.5	16.5%	3.4	23.9
06.1.5	<b>Electrical Power Subsystem</b>			928.8	17.3%	160.8	1089.6
06.1.5.a	Solar Arrays			742.8	15.0%	111.4	854.2
06.1.5.b	Power Cable and Harness Subsystem (C and HS)			60.0	50.0%	30.0	90.0
06.1.5.c	Power Management & Distribution			104.6	15.5%	16.2	120.8
06.1.5.d	Battery System			21.4	15.0%	3.2	24.6
06.1.6	<b>Thermal Control (Non-Propellant)</b>			315.6	18.0%	56.8	372.4
06.1.6.a	Active Thermal Control			4.9	18.0%	0.9	5.7
06.1.6.b	Passive Thermal Control			239.4	18.0%	43.1	282.5
06.1.6.c	Semi-Passive Thermal Control			71.4	18.0%	12.8	84.2
06.1.7	<b>Structures and Mechanisms</b>			525.1	18.0%	94.5	619.7
06.1.7.a	Structures			386.8	18.0%	69.6	456.5
06.1.7.b	Mechanisms			138.3	18.0%	24.9	163.2
06.1.8	<b>Propulsion System</b>			906.7	10.9%	98.9	1005.6
06.1.8.a	Propulsion Hardware (EP)			114.0	14.1%	16.0	130.0
06.1.8.b	Propellant Management (EP)			465.3	11.9%	55.3	520.6
06.1.8.c	Power Processing Unit (PPU)			160.0	12.4%	19.8	179.8
06.1.8.d	Reaction Control System Hardware			167.4	4.6%	7.8	175.2
06.1.9	<b>Propellant</b>			11869.2	0.0%	0.0	11869.2
06.1.9.a	Propellant (EP)			10958.3	0.0%	0.0	10958.3
06.1.9.b	Pressurant			34.3	0.0%	0.0	34.3
06.1.9.c	RCS Propellant			876.6	0.0%	0.0	876.6

### Alternative Flight System Architecture

An alternate flight system based on a Separable Spacecraft Architecture in which the spacecraft could separate into two parts, a SEP stage (SS) and a host spacecraft (S/C) was also considered. The conceptual design for the separable spacecraft architecture has a SEP stage that would include the electric propulsion subsystem, the solar arrays, and the power management and distribution subsystem. It would also include an articulated high-gain antenna for long-range communications with Earth, short-range (omnidirectional) communications with the host S/C, Attitude Control Subsystem (ACS), Reaction Control Subsystem (RCS), and Command and Data Handling (C&DH). The SS would be responsible for transporting the host S/C + SS to the vicinity of the target, post-capture rendezvous with the S/C, and transporting the system back to the final destination. Articulation of the high-gain antenna would be essential to minimize the number of spacecraft rotations with the captured NEA just to point the antenna at Earth.

The host spacecraft would separate from the SEP stage to capture and de-tumble the asteroid. It would have the following spacecraft functions including ACS, RCS, C&DH, short-range communications with the SEP stage, and asteroid capture mechanism. It would also include the instrument package for *in situ*

characterization of the asteroid and cameras to assist in the asteroid capture. The host S/C would include the RCS system for agile maneuvering in the proximity of the target body and to de-tumble the asteroid.

*Spacecraft Architecture Pros and Cons* – The separable spacecraft architecture would provide the advantage that the S/C used to capture the asteroid would be smaller and more nimble than the single spacecraft with its large solar arrays and electric propulsion subsystem. It could also use the SEP stage as a communications relay station to provide high-data rate communications with Earth during the asteroid capture and de-tumble activities. The disadvantages of the separable spacecraft approach would be its likely significantly higher cost (because essentially two complete spacecraft must be developed), the necessity for autonomous rendezvous and docking with the SEP stage in deep space, and its limited energy capability once it separates from the SEP stage.

### **Capture Mechanism**

The same basic capture mechanism is assumed regardless of the spacecraft architecture. The top (the end opposite from the Hall thrusters) of the spacecraft would include the instrumentation for asteroid characterization and the capture mechanism. The capture mechanisms would include inflatable deployable arms, a high-strength bag assembly, and cinching cables. When inflated and rigidized, four or more arms connected by two or more inflated circumferential hoops would provide the compressive strength to hold open the bag, which would be roughly 10 m long x 15 m in diameter as shown in Fig. 2. This capture mechanism concept could accommodate a wide range of uncertainty in the shape and strength of the asteroid. The deployed bag assembly would be sized to accommodate an asteroid with a 2-to-1 aspect ratio with a roughly cylindrical shape of 6-m diameter x 12-m long.

The exterior finish of the capture bag assembly is designed to passively maintain the surface temperature of the captured asteroid at or below its nominal temperature before capture.

## VI. MISSION DESIGN

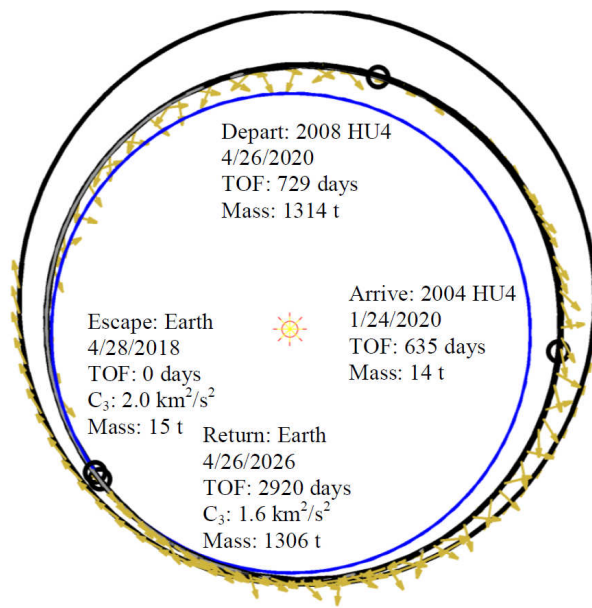
The key mission drivers are the  $\Delta V$  needed for the round trip, the upper limit on the round trip flight time, and the size and mass of the target body. The combination of flight time and upper limit on expected mass of the target determine the SEP system power and propellant quantity that would be needed, which to a first order size the spacecraft and launch vehicle. The size, spin-state, composition, and associated uncertainties of the asteroid's characteristics would also drive the designs for the capture mechanism and de-spin propellant required. The flight system described in Section V would be capable of being launched on a single Evolved Expendable Launch Vehicle (EELV) and could retrieve NEAs with masses up to about 1,000,000 kg with total round trip flight times of 6 to 10 years.

The overall mission design, illustrated in Fig. 8, is built around the 40-kW solar electric propulsion system described above. The spacecraft would be launched to low-Earth orbit (LEO) using a single Atlas V 551-class launch vehicle. The SEP system would then spiral the spacecraft to a high-Earth orbit where a lunar gravity assist (LGA) puts the vehicle on an escape trajectory with a positive  $C3$  of about  $2 \text{ km}^2/\text{s}^2$ . The SEP system would complete the heliocentric transfer to the target NEA. Once at the asteroid, the mission design would allocate 90 days for characterization of the NEA, determination of its spin state, creation of a detailed shape model, and the subsequent capture and de-tumbling of the asteroid. The SEP system would transport the NEA back to the vicinity of the Earth-moon system where another lunar gravity assist would be used to capture the vehicle plus NEA to a slightly negative  $C3$ . Approximately 4.5 months after the LGA, the asteroid and spacecraft would complete the transfer to a stable high lunar orbit with essentially zero additional  $\Delta V$ .

### Earth Departure, Rendezvous and Pre-Capture Operations

As a proof of concept it was desirable to perform the trajectory analysis using a known small near-Earth asteroid. Candidate asteroid targets were selected from the data base of known NEAs by searching for those that had close approaches to Earth. NEAs were first selected that make a close approach to Earth of  $< 0.2 \text{ AU}$  at a relatively low relative velocity ( $< 3 \text{ km/s}$ ). The close approach date was then used as an initial guess for the date that the ACR spacecraft could return the asteroid to the Earth-moon system. The maximum return mass was found by optimizing just the return leg trajectory for maximum return mass with fixed power and unbounded NEA departure mass. The initial guess for the Earth escape and asteroid encounters could typically be very rough: Lambert fits with 300 d (or so) Earth-to-NEA and NEA-to-Earth legs converge for initial return masses of  $< 100 \text{ t}$ . Larger return masses could usually be accommodated by moving the Earth departure and NEA arrival dates earlier in year steps to provide more time for thrusting on the return leg.

Because there are many known but uncharacterized NEAs, it is possible to find a few small objects with orbits similar enough to Earth's to return large ( $\sim 1000 \text{ t}$ ) masses. With the additional constraint that a potential target should have an upcoming observation opportunity, 2008 HU4 provides an example target for return of an entire NEA. The pertinent design parameters are listed in Table 4. The estimated  $\Delta V$ s for this particular NEA are: LEO to lunar gravity assist =  $6.6 \text{ km/s}$ ; heliocentric transfer to the NEA =  $2.8 \text{ km/s}$ ; NEA return to lunar gravity assist =  $160 \text{ m/s}$ . Since it is not known what type of asteroid 2008 HU4 is, its mass is highly uncertain. Table 5 summarizes the results assuming the asteroid mass is as low as  $250 \text{ t}$  and as high as  $1,300 \text{ t}$ . The trajectory details to return up to  $1300 \text{ t}$  are presented in Fig. 8. Only the heliocentric portion of the trajectory is described in Table 4 and Fig. 8.



**Figure 8.** Example mission returning 2008 HU4, a small (~7 m), 1300 t of NEA with a radar opportunity in 2016.

**Table 4.** Asteroid retrieval trajectory design parameters based on 2008HU4.

Parameter	Value	Comments
SEP Power (EOL)	40 kW	
Specific Impulse, $I_{sp}$	3000 s	
EP System Efficiency	60%	
Spacecraft Dry Mass	5.5 t	
Launch: Atlas V 551-class		
Launch Mass to LEO	18.8 t	
Spiral Time	2.2 years	LEO to lunar gravity assist
Spiral Xe Used	3.8 t	
Spiral $\Delta V$	6.6 km/s	
Mass at Earth Escape	15.0 t	
Transfer to the NEA		
Earth Escape $C_3$	2 km <sup>2</sup> /s <sup>2</sup>	Lunar gravity assist
Heliocentric $\Delta V$	2.8 km/s	
Flight Time	1.7 years	
Xe Used	1.4 t	
Arrival Mass at NEA	13.6 t	
NEA Stay Time	90 days	
Assumed Asteroid Mass	1300 t	
Transfer to Earth-Moon System		
Departure Mass: S/C + NEA	1313.6 t	
Heliocentric $\Delta V$	0.17 m/s	
Flight Time	6.0 years	
Xe Used	7.7 t	
Mass at lunar gravity assist	1305.9 t	
Escape/Capture $C_3$	2 km <sup>2</sup> /s <sup>2</sup>	Lunar gravity assist
<b>Total Xenon Used</b>	<b>12.9 t</b>	
<b>Total Flight Time</b>	<b>10.2 years</b>	

**Table 5.** Interplanetary (Earth escape to Earth capture) trajectories for example missions.

Target Asteroid Designation	Assumed Mass of Asteroid Returned (t)	Launch Vehicle	Xe (not including the Earth spiral) (t)	Earth Escape Date	Flight Time (not including the Earth spiral) (yrs)	Arrival C3 (km <sup>2</sup> /s <sup>2</sup> )
2008 HU4	250	Atlas V 521-class	5.0	4/27/2022	4.0	1.8
2008 HU4	400	Atlas V 521-class	5.2	4/27/2021	5.0	1.7
2008 HU4	650	Atlas V 521-class	6.5	4/27/2020	6.0	1.6
2008 HU4	950	Atlas V 551-class	8.9	4/28/2019	7.0	1.6
2008 HU4	1300	Atlas V 551-class	9.1	4/28/2018	8.0	1.6
2008 HU4	200*	Atlas V 551-class	8.7	8/15/2017	8.0	0.0

\*Returned to Sun-Earth L2.

The first five rows of Table 5 indicate that additional flight time would be required to return larger asteroid masses. However, the return date would be fixed to when the NEA naturally has a close encounter to Earth, so the additional flight time would come at the expense of earlier launch dates. Also, larger return mass would typically require additional propellant, which would increase the wet mass of the spacecraft and requires larger launch vehicles. Higher power SEP systems could reduce the flight times.

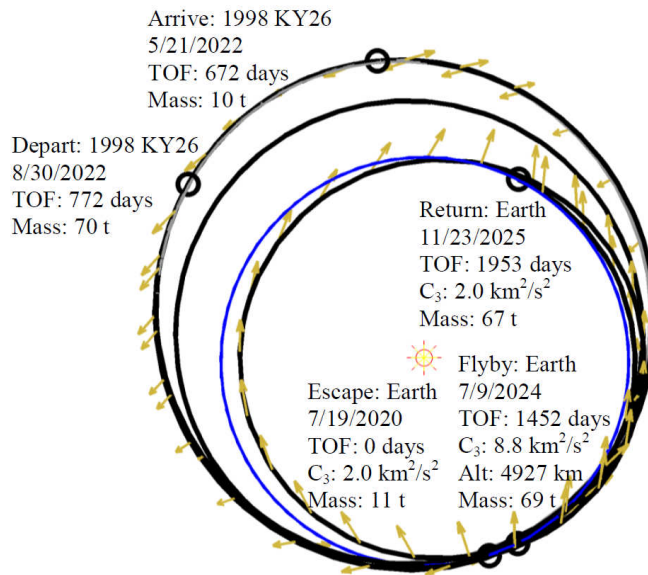
Direct transfers to Sun-Earth L2, without an intermediate lunar gravity assist, were also examined. The mission-specific parameters for a representative trajectory are shown in row six of Table 5. The process for this is to connect the low-thrust interplanetary trajectories to a stable manifold that asymptotically approaches L2. The first step is to generate a table of state vectors that define the manifold. Then the state (position and velocity) of the target over the time span of interest are called from an ephemeris and rotated into the same frame as the manifold data.

A particularly useful frame is an Earth-centered radial-tangential-normal (RTN), where the radial component is Earth’s position with respect to the sun and the normal component is Earth’s orbital angular momentum, because the manifolds are independent of the reference epoch in this frame (i.e. they don’t significantly vary over Earth’s orbit around the sun). A heuristic cost function may be calculated by taking the difference in position between the NEA and the manifold and dividing it by an assumed transfer time (e.g., two years) to get an intercept  $\Delta V$ , then adding the difference in velocities to get an approximate total  $\Delta V$  to match states and place the NEA on the manifold. This cost function is three dimensional and can be parameterized by 1) the absolute time along the NEAs orbit; 2) the relative time from L2 on the manifold; and 3) the arrival position along the L2 orbit. A direct transfer to Sun-Earth L2 would require more  $\Delta V$  than capturing with a lunar flyby and would significantly reduce the return mass capability.

### **Pick Up a Rock Alternative Mission Approach**

In the *Pick Up a Rock* approach the plan would be to gather a single ~7-m diameter rock off the surface of a >100-m asteroid or, failing that, collect a similar mass of regolith or smaller rocks. Proof-of-concept trajectories using asteroid 1998 KY26 as the example were performed. 1998 KY26 is known to be a C-type carbonaceous asteroid. The relatively small number of asteroids with known types makes it more difficult to find potential targets with orbital characteristics that would permit large return masses. In this case, 1998 KY26 would require more  $\Delta V$  to return a sample than was the case for asteroid 2008 HU4. For 1998 KY26 “only” 60 t could be returned as indicated by Fig. 9 and the first row in Table 6. The asteroid 2008 EV5 (not examined here) is another C-type asteroid from which sizable samples could be returned.

The difference between the first and second rows of Table 6 is the addition of an Earth gravity assist in row eight to leverage down the naturally high encounter velocity of 1998 KY26. Table 8 also shows results for the NEA 2000 SG344, which has an orbit very similar to Earth’s and would permit very large return masses. However the return trajectory is very sensitive to arrival  $C_3$ , where the addition of  $0.1 \text{ km}^2/\text{s}^2$  would double the return mass (comparing rows 3 and 4). In this case it appears that the sensitivity is due to continuous thrusting on the return leg, and increasing flight time wouldn’t help because of the synodic phasing of the NEA and Earth (moving the encounter earlier by a year would remove the low- $\Delta V$  transfer). Again, as demonstrated in the final row of the Table 6, the additional  $\Delta V$  of removing all of the arrival  $C_3$  to capture directly onto the L2 manifold would dramatically reduce the return mass capability.



**Figure 9.** Example mission returning 60 t from a well-characterized 30-m carbonaceous NEA.

**Table 6.** Interplanetary (Earth escape to Earth capture) trajectories for example missions.

Target Asteroid Designation	Assumed Mass of Returned Material (t)	Launch Vehicle (baseline)	Xe (not including the Earth spiral) (t)	Earth Escape Date	Flight Time (not including the Earth spiral) (yrs)	Arrival $C_3$ , ( $\text{km}^2/\text{s}^2$ )
1998 KY26	30	Atlas V 521-class	4.9	11/11/2019	4.7	2.0
1998 KY26	60	Atlas V 521-class	4.2	7/19/2020	5.3	2.0
2000 SG344	1800	Atlas V 521-class	1.8	3/8/2027	2.6	2.0
2000 SG344	3600	Atlas V 521-class	1.5	2/14/2027	2.6	2.1
2000 SG344	100*	Atlas V 551-class	6.3	4/20/2024	6.5	0.0

\*Capture directly to Sun-Earth L2 via a stable manifold. All others assume lunar capture to S-E L2.

### ***Get a Whole One Pre-Capture Operations***

Since the targeted NEA is only ~7 m in diameter, the rendezvous would likely need to implement a search prior to encountering the NEA. For example, for 2008 HU4 (without radar astrometry in 2016), the ellipse uncertainty is ~ 200,000 km x 1,000,000 km. Assuming a navigation camera similar to the Dawn framing camera, the NEA should be visible from a distance of 100,000 km to 200,000 km.

During the 3 months prior to rendezvous, images and delta-difference one-way range (DDOR) measurements would be obtained to constrain the NEA position and obtain preliminary information for further approach and close-up characterization. The spacecraft rendezvous point could be defined at about 20-30 km out, with a residual speed of less than 1-2 m/s.

In the far-approach phase the spacecraft would approach and loiter in the vicinity of the target body by following a ground-provided SEP thrusting profile. The range to the target may be several kilometers at this point. This should permit target-relative position (target  $\rightarrow$  S/C inertial position) estimation using on-board GNC sensors and functions. Once the relative state is known, the on-board station-keeping algorithms would use this data to execute desired target-relative proximity motions.

A 7-m NEA has very little gravity, less than  $10^{-6}$  m/s<sup>2</sup>. Hence, the incremental approach from 20-30 km down to 1 km would be a function of the time needed to analyze images/data. A 1-km standoff distance (if hovering), or close approach distance (if slow hyperbolic flybys are adopted) would be a good distance for sub-meter imaging. Full characterization would be done at distances from 1 km to 100 m, over varying phase angles. Note that orbiting this small NEA is theoretically possible but would most likely be outside of the spacecraft proximity  $\Delta V$  capabilities (too small  $\Delta V$  maneuvers needed). Implementing slow hyperbolic flybys would require about 3-4 days per flyby accounting for planning maneuvers and processing tracking data.

Being most likely a fast rotator (from current statistics on < 100-m NEAs, the spin period may be as fast as 10 min), a 1-2 Hz frame rate camera would be needed for resolving the spin state. To account for a possible lack of surface features to navigate with, visible images combined with IR images would be a must-have capability. Gathering full coverage data with the candidate instrument suite given in Table 7 would total about 30-40 Gb at most within a couple of months.



In the middle-approach phase a target-relative trajectory (inertial) would be executed using relative position estimates to bring the S/C to within a few hundred meters of the target, and park it there for an extended period of time. Parking in this context implies loose station-keeping (i.e., back-and-forth coasting inside a control dead-band box defined in inertial space in the vicinity of the target body). It should be possible to use a radar altimeter during this phase. This implies identification of model parameters that could be used to propagate target body orientation as a function of time on-board. Although it could be, spin state identification would not be required to be an autonomous function.

Assuming radar observation opportunity prior to rendezvous constrain the mass uncertainty to a factor of 2, the spacecraft would need to come within 20 m of the NEA, drifting by it at less than 10 cm/s, for the radio experiment to reduce the mass uncertainty. As an alternative, a landing probe or beacon on the surface could be used. In addition to beaconing, surface experiments could be used for testing the surface mechanical and electrical properties prior to any capture and de-spinning activities.

In addition to the candidate instrument suite in Table 7 a Gamma Ray Neutron Spectrometer (such as the GRaND instrument on Dawn) could be considered for measuring the surface composition, and a Regolith X-ray Imaging Spectrometer (such as REXIS on OSIRIS-REx) could be considered for X-ray spectroscopy.



**Table 7.** Candidate instrument suite.

				N/A	
Parameters	Vis Cam (OpNav)	Vis Cam (ProxOps)	NIR Spec	LIDAR	CubeSat probes; pod
Format/Heritage	High resolution	Ecliptic	Pushbom M3	3D flash STORRM	3-4 x 1 U; 1-2 x 2 U? 3-axis accels; comm; explosive pod? (BATC)
FOV (deg)	2 x 2	10 x 10	25 x 1	< 200 mrad	~5 x 5
IFOV	30 $\mu$ rad	200 $\mu$ rad	1 mrad	0.2 mrad	100 $\mu$ rad
Range	0.4-0.9 $\mu$ m	0.45-0.9 $\mu$ m	0.4-3 $\mu$ m	1 $\mu$ m < 30 km	RGB
Resolution	<0.1 m @ 1 km	~ 0.2 m @ 1 km	2 m @ 1 km	< 200m @ 1 km	~1 cm @ 50 cm
Mass (kg)	5	2	8	20	1 kg/cubesat; 5kg/pod
Power (W)	15	5	10	50	N/A
Telemetry rate	12 Mbits/image	12 Mbits/image	2 Mbits/sample	0.1 Mbits/sample	5 Mbps

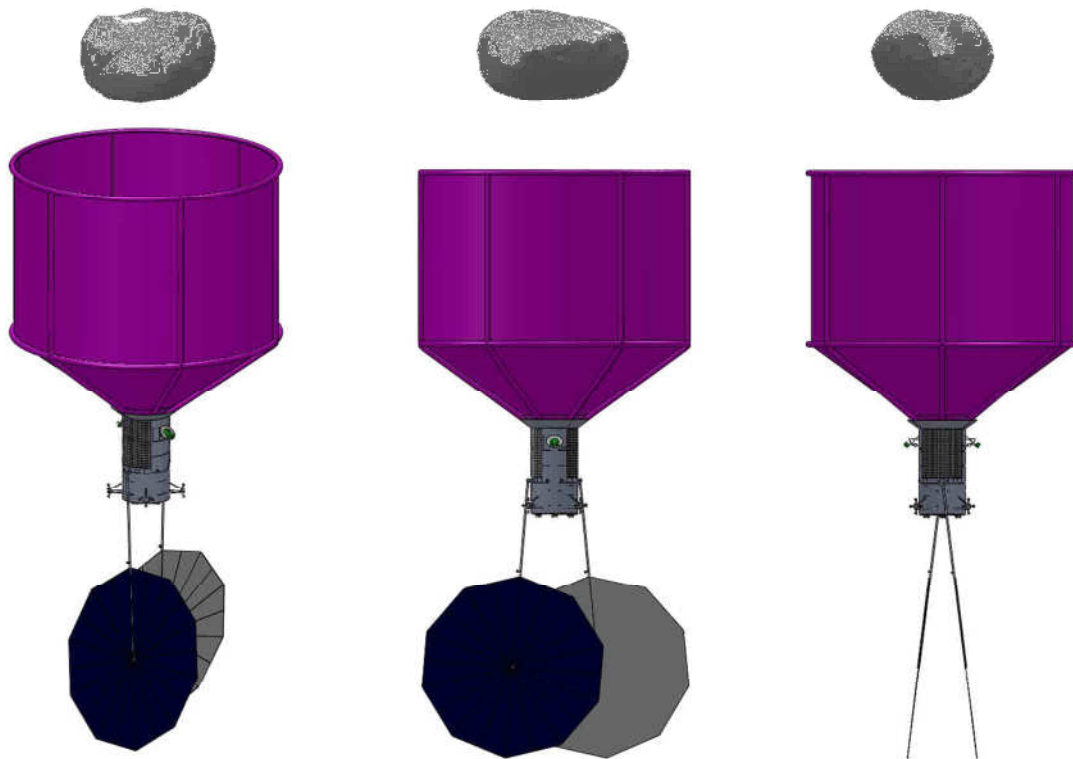
### Capture and Post-Capture Operations

The conceptual mission design allocates up to 90 days for the spacecraft to characterize the NEA, capture it, and subsequently de-tumble it. These processes, which would be essential for an asteroid return mission, are outlined below.

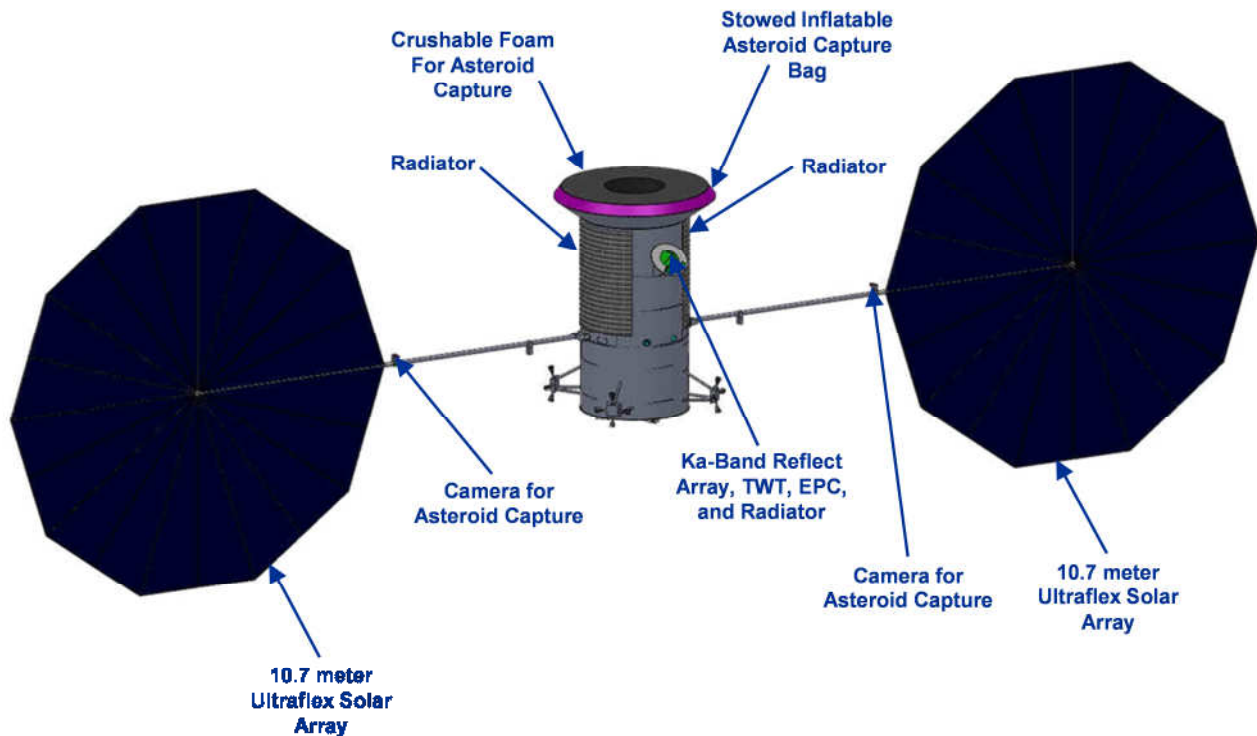
**Capture** – This process must capture the NEA, which is considered to be a tumbling, non-cooperative object. The capture process must be executed largely autonomously in deep space. Sometime after the spin state has been identified, the S/C would approach the target body by following a series of closure steps consisting of several descent-stationkeeping-descent cycles. The guidance subsystem would use radar-altimeter aided relative position estimates (inertial) to plan and execute these trajectories. The final stationkeeping location may be tens of meters from the target center. The S/C would then match the surface velocity and primary spin state of the target while maintaining station at the final station-keeping location. In the single spacecraft architecture, to make the spacecraft nimble enough to do this it may be necessary to provide the capability to fold back the large solar arrays as indicated in Fig. 10. In this configuration, the solar cells would still be facing outward, and the arrays can still generate at least 3.8 kW of power even if they're off-pointed from the sun by up to 85 deg. Final closure motion would be initiated while remaining in the synchronized motion state. Control would be disabled just before capture and re-established following a successful capture and securing of the target body.

The GNC algorithms to rendezvous with a non-cooperative space object exist for objects in Earth orbit. The algorithms, developed for rendezvous and sample capture, were exercised in a DARPA-funded study. That study demonstrated the capture of a defunct, spinning and wobbling, non-cooperative object in Earth orbit. During capture, the asteroid would be positioned inside the capture mechanism and

there would only be a small residual relative velocity between the asteroid surface and the capture mechanism.



**Figure 10.** Conceptual spacecraft with solar arrays folded back to facilitate matching the asteroid's spin state during the capture process.



**Figure 11.** Conceptual flight system configuration before deployment of the capture mechanism showing the locations of the cameras on the solar array yokes used to verify proper deployment and subsequently to aid in the asteroid capture.

To capture the asteroid multiple "draw strings" would cinch-close the opening of the bag and also cinch-tight against the bulk material. The tightly-cinched bag containing the asteroid would be drawn up against a ring that constrains its position and attitude so that its center-of-mass is controlled and forces and torques could be applied by the S/C. Cameras positioned on the solar array yokes as indicated in Fig. 11 would be used to determine if the capture mechanism was correctly deployed, and to aid in the asteroid capture. A ring would be between the bag assembly and the body of the S/C for the purpose of imparting forces on the bulk material through the bag. Although not shown in Fig. 11 it may be necessary to include a "Stewart Platform" in which six linear actuators would allow the ring to be moved in x, y, z, roll, pitch, and yaw. This would enable the center-of-mass of the final bagged asteroid to be positioned within an acceptable range of the SEP thruster gimbals so that the resultant thrust vector from all the EP thrusters could nominally be pointed through the center of mass of the whole assembly.

Due to the residual velocity between the asteroid and the spacecraft, there would be some "impact" as the asteroid is captured. Although, since the asteroid would be much more massive than the spacecraft, it is perhaps better to think of this as the asteroid capturing the spacecraft. Nevertheless, once the spacecraft and asteroid are tightly secured together, the spacecraft could then de-tumble the combination.

In the Separable Spacecraft Architecture, after successful de-tumbling of the NEA the SEP Stage would descend to rendezvous with the detumbled S/C + asteroid system. This system would now be deemed a co-operative target in the sense that it could reorient itself to face the SS if needed.

**De-spin** – To estimate the time and propellant required to de-tumble the asteroid, the object was assumed to have a mass of 1,100 t, be rotating at 1 RPM about its major axis, and have a cylindrical shape of 6-m diameter x 12-m long. The 200-N RCS thrusters would be used for this process and are assumed to have a moment arm of 2 m. The angular momentum of spacecraft with asteroid would be  $1.7 \times 10^6$  N·m·s, and the major and minor moments of inertia (MOIs) with the spacecraft attached are estimated to be  $1.65 \times 10^7$  kg·m<sup>2</sup> and  $5.52 \times 10^6$  kg·m<sup>2</sup>. The resulting time for despin would be ~ 33 minutes assuming continuous firing, and approximately 306 kg of propellant would be required.

**Pick Up a Rock Considerations** – This scenario would also make use of a high-strength bag to capture a large rock on the surface of the asteroid. If no rock on the surface of the asteroid is suitable, then it would be necessary to collect bulk regolith instead. It may be possible to accomplish this by anchoring the S/C onto the surface, and having a "snow blower" that could pivot around the anchor point so as to fill the sample bag with collected material entering via a chute from the snow-blower. The snow-blower, just like its name-sake on Earth, would use forces imparted by a spinning blade to fling the regolith into the chute, where it would propagate by its own inertia along the chute into the bag. The opening of the bag would have previously been cinched over the chute so that the bulk material cannot escape. Note that, unlike terrestrial "bagging lawn mowers," no provision would need to be made for escape of air.

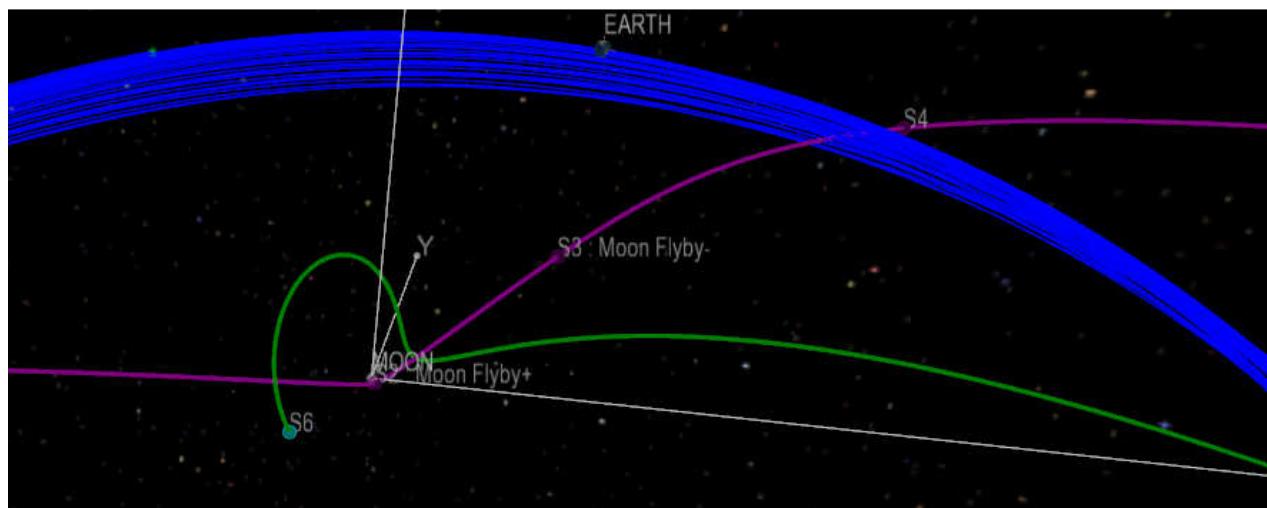
If it is desired to collect up to 1000 cubic meters of loose regolith, and it is assumed that the snow-blower could (on successive passes) dig up to 1 meter deep, and would be able to process an annulus ranging from 3 to 10 meters away from the anchor pivot, then each anchor point could provide up to about 250 cubic meters of material. So some 4 different anchor points must be assumed.

The bag would need to comfortably accommodate 1000 cubic meters of sample, which means that it would be more than 10 meters in diameter and 10 meters long. This would be too large to fit in present-day launch shrouds, so it must be deployed. Having the "arms" that open the bag be inflated tubes so that the whole assembly would be made of fabric and deploy out of a compact package seems attractive. Similarly, the chute and support for the snow-blower may also be inflated. Computer-controlled winch cables would cinch the drawstrings of the bag(s), modulate the radius of operation of the snow-blower, etc.

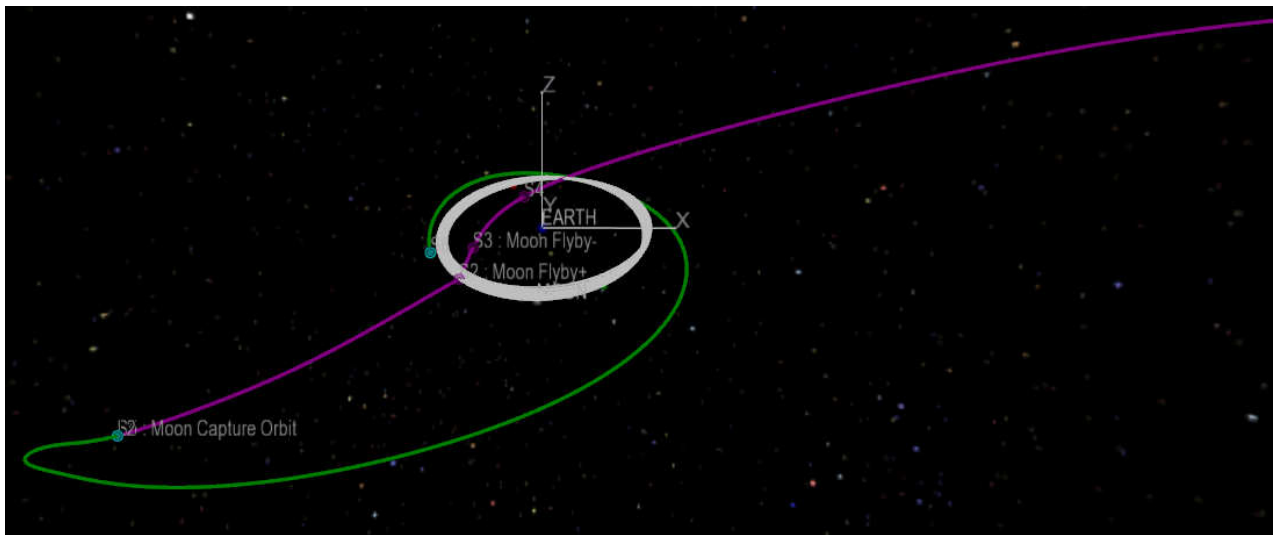
On another side of the S/C would be the anchoring. Currently this is envisioned as one or more auger-type anchors that can be "screwed" into the terrain. Two counter-rotating augers (one right-hand and one left-hand) can provide anchoring with no net torque reaction. These anchors can be released so that multiple anchor points can be provided as needed to acquire 1000 cubic meters of regolith. Opposite the anchor assembly is the short-range communication antennas, camera platform, and other sensors needed for the regolith gathering activity. Since the anchor, by definition, is on the side facing the asteroid, this side faces space, and provides a good attach point for a camera boom giving a proper vantage-point for managing either the snow-blower or the free-flight approach to guide the bag to envelop a rock.

### Getting to Lunar Orbit

The large mass of the captured asteroid and relatively low thrust available from the Hall system, require that the spacecraft + asteroid must have the  $\Delta V$  necessary to target the lunar gravity assist well before the lunar encounter. This requirement, which appears feasible, is not unlike the requirement of the Dawn mission to have a forced coast period well before the Mars Gravity Assist. The asteroid would arrive into the Earth-Moon system on a hyperbolic trajectory with positive  $C3$ , but after the lunar gravity assist, would have a negative  $C3$  with respect to the Earth and would be gravitationally captured. The flyby could be targeted such that it would bring the asteroid back into a high lunar orbit, however, such an orbit would not be stable and the spacecraft would not remain captured by the Moon without additional  $\Delta V$  from the SEP system. This is illustrated in Figs. 12 and 13 which show the flyby sequence in the Moon and Earth centered frames, respectively. The illustrated sequence would require no  $\Delta V$  after targeting the flyby condition.

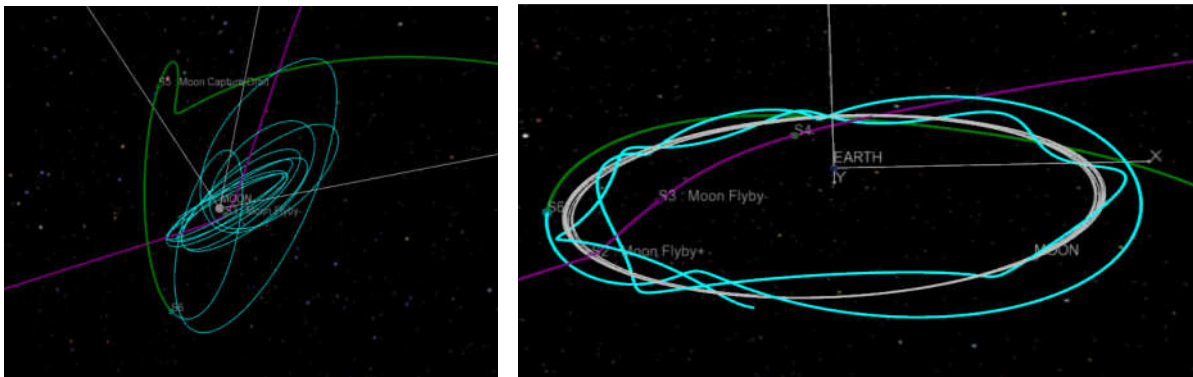


**Figure 12.** Lunar Gravity Assist and Lunar Arrival in a Moon-Centered Frame.



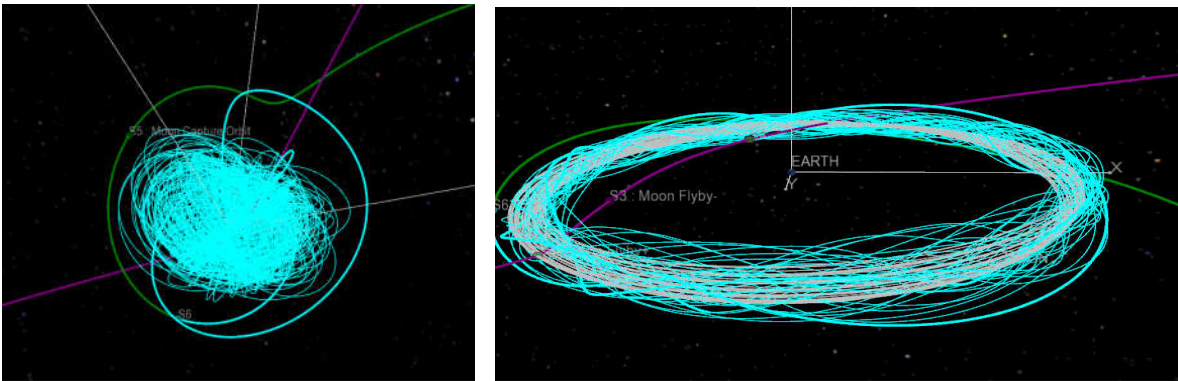
**Figure 13.** Lunar Gravity Assist and Lunar Arrival in an Earth-Centered Frame.

We estimate that the lunar orbit could be maintained with station-keeping on the order of 10 m/s  $\Delta V$  per year. However, the propulsion system would be limited in the rate it could apply the  $\Delta V$  given the thrust limitations of the Hall system and the mass of the asteroid. The baseline mission concept described above does not currently include the propellant necessary for multi-year station-keeping. A xenon resupply or an additional propulsion module may be necessary for the long-term orbit maintenance of the asteroid. A proof of concept lunar orbit insertion was simulated, and a 25-N thruster was sufficient for insertion into a stable lunar orbit. The 25-N thruster lowered the asteroid *C3* with respect to the moon below  $-0.1 \text{ km}^2/\text{s}^2$ . The transition to a stable lunar orbit is shown in Fig. 14.



**Figure 14.** Stable Lunar Orbit Insertion is the moon centered (left) and Earth centered (right) frame.

After lowering the asteroid to a stable lunar orbit, a high-fidelity propagation was performed using Copernicus [38] and all potential perturbations for a demonstration of stability. The asteroid remained captured in lunar orbit after 20 years of simulation without any additional station-keeping as shown in Fig. 15.



**Figure 15.** Long duration (20 years) stability simulation for the captured asteroid placed in lunar orbit.

Additional work still remains for the preliminary design of final insertion operations and the final asteroid parking orbit. This analysis is necessary to determine both the station-keeping requirements to maintain the asteroid in orbit either in a high lunar orbit or potentially in a Lagrange halo orbit and the necessary control authority (i.e. thrust) and  $\Delta V$  to transfer the orbit into a long duration stable orbit; likely around the Moon. For a long duration solution, a propellant resupply or an additional propulsion stage after Earth arrival may be required depending on the outcome of the detailed stability analysis.

### **Cislunar Operations**

In the context of human exploration, the NEA could be used to gather engineering knowledge and assist in the development of tools and operations. In fact, having the NEA close by would provide a compelling mission objective outside of LEO for an astronaut crew to take it apart. The relative proximity of the NEA will make affordable the use of more complex payloads. Several activities could take place after the NEA is placed in cislunar orbit to benefit human exploration, the development of ISRU, and science. The following measurements could be obtained by both robotic spacecraft and crewed missions.

- Remote sensing imaging obtained over various wavelengths and phase angles for composition, morphology, high resolution mapping of the entire surface.
- Stereo techniques and ranging instrumentation would enable high resolution digital terrain models to be constructed to assist in further surface activity planning.
- Surface and sub-surface element and volatile composition obtained using gamma ray and neutron spectrometer such as the GRaND instrument on the Dawn spacecraft, or using X-ray spectroscopy such as the Regolith X-ray Imaging Spectrometer (REXIS) currently proposed on the OSIRIS-Rex mission.

These data would directly feed into subsequent surface and subsurface sampling operations planning, and the corresponding development of equipment and tools. Specific surface and subsurface operations could involve:

- Taking core samples at various depths for further processing tests on Earth, dust mitigation, and measuring with more accuracy mechanical and electrical properties to compare with remote sensing surveys.
- Testing of large-scale sample acquisition using various collection approaches, leading to subsequent mining activities.
- Testing of anchoring procedures and devices.
- Verification and validation of proximity operations procedures to be implemented at deep-space locations such as the moons of Mars or other near-Earth asteroid destinations.
-

**Mining/Benefaction/Extraction/Fabrication** – The technical requirements for mining asteroids would be as diverse as those used on Earth. Plausible asteroidal feedstocks cover a vast range of chemical compositions and physical properties, suggesting a careful tailoring of drilling, blasting, cutting, and crushing hardware to the chosen target—and placing a premium upon prior knowledge of the nature of the target material. Indeed, one of the central reasons for choosing a water-bearing C-type asteroid as our first target is that the chemical and physical properties of these materials are both rather well understood and benign (very low crushing strength and high content of desirable volatiles). Bench-scale prototypes of systems for processing asteroidal materials have been developed in laboratories on Earth, in some cases using real meteorite materials as the feedstock.

Further development of equipment for effecting mineral separation on asteroids, a process that would become more important in potential future missions to volatile-poor metal-bearing asteroids, could await both experience with the first retrieved asteroid and laboratory investigations on meteorite samples. Beneficiation (the selective enrichment of desired minerals) may in many cases require crushing of the target rock, followed by magnetic, electrostatic, or other means of concentration. Such concentration technologies would also be of considerable value on the Moon for the concentration of potential ores such as ilmenite.

The extraction of a desired material (water, carbon, nitrogen, iron, nickel, sulfur, platinum-group metals, etc.) may involve either chemical or physical processes. Examples include thermal decomposition of clay minerals and hydrated salts to release water vapor, Mond-process volatilization and separation of metallic iron and nickel, electrolysis of molten silicates, or any of dozens of other candidate techniques which would be chosen for their relevance to the intended target and the desired product.

Fabrication of products would likewise involve a host of different possible processes. Production of high-purity water for propulsion or life-support use may require controlled distillation of the first-cut water driven off by heating the asteroid material to separate the water from undesirable contaminants such as volatile organics and sulfur and chlorine compounds. Likewise, production of high-purity iron (99.9999% iron has the corrosion resistance of stainless steel and a very high tensile strength) could be effected by Mond-process volatilization of native metal alloys, simple distillation to separate iron and nickel carbonyls, and controlled thermal decomposition of the iron pentacarbonyl vapor in a heated mold (at about 200 Celsius and 1 atm pressure). Fabrication of refractory bricks or aerobrakes could be done by microwave sintering of appropriate metal-oxide mixtures in molds. These candidate fabrication processes could be developed sequentially as our experience with in-space processing grows, and as new classes of asteroidal feedstock become available.

**Science** – The immediate science goals of our proposed asteroid retrieval mission are to understand the physical and chemical history of the body as a whole. Certain “classical” analytical procedures, such as assays for the content of a wide variety of organic constituents, could easily be done on small samples (one kilogram would qualify as a “huge” sample), and would most likely be done in well-equipped laboratories on Earth. Unraveling the fragmentation, regolith-formation, ejection, and gardening processes on the body, presumably best done by examining the concentrations of cosmogenic (cosmic-ray-produced) noble-gas nuclides and radionuclides at many sites and depths on the body may best be done by a miniaturized mass spectrometer with a sampling system capable of collecting samples and heating them in a sealed chamber, supplemented by a sensitive and well-shielded radiation detector. Possible regional variations in bulk elemental composition, such as would be caused by accumulation of large chunks of foreign material from impactors, could be detected by gamma-ray spectrometric (GRS) analysis, although this technique is insensitive to small fragments of foreign material mixed into the surface regolith. The GRS instrument would have to be deployed on or very close to the surface at multiple locations. The sites of the GRS analyses would be chosen on the basis of spectral mapping data with high spectral and spatial resolution, which can identify the spectral features of major and minor

minerals. Both the GRS and spectral mapping instruments could be straight-forward adaptations of existing flight hardware.

### Cost Estimate

The GRC COMPASS team generated an initial cost estimate for the Asteroid Capture and Return mission concept. This cost estimate, in FY'12 \$, is based on the following assumptions.

- Prime contractor design, test & build based on NASA-provided specs
- Proto-flight development approach (except power and propulsion subsystems)
- Single ground spares included where applicable
- Assumes all technologies are at TRL Level 6 – the estimate does not include any cost for technology development up to TRL 6
- The cost estimate:
  - Represents the most likely estimate based on cost-risk simulation results
  - Includes mass growth allowance
  - Is a parametric estimate based on mostly mass-based Cost Estimating Relationships (CERs) using historical cost data
  - Includes planetary systems integration wraps
  - Includes flight software costs based on analogy to the Dawn flight system
  - Does not include the cost of propellant

With these assumptions the estimate of the Prime Contractor cost including fee given in Figs. 16 and 17 was generated. The total cost for the first unit including DDT&E is \$1.36B. The recurring cost for the flight hardware is estimated to be \$0.34B. The total cost for the first ACR mission is estimated at \$2.6M as indicated in Fig. 17 including NASA insight/oversight, the cost of the launch services, mission operations, and reserves.

<b>WBS</b>	<b>Description</b>	<b>DDT&amp;E Total (FY12\$M)</b>	<b>Flight HW Total (FY12\$M)</b>	<b>DD&amp;FH Total (FY12\$M)</b>
06.1.1	Payloads	65.0	28.0	93.0
06.1.2	Command & Data Handling	50.1	18.3	68.5
06.1.3	Communications and Tracking	29.7	13.7	43.4
06.1.4	Guidance, Navigation, and Control (GN&C)	17.2	12.7	29.9
06.1.5	Electrical Power Subsystem	190.3	62.1	252.4
06.1.6	Thermal Control (Non-Propellant)	26.0	13.2	39.3
06.1.7	Structures and Mechanisms	52.1	26.0	78.0
06.1.8	Propulsion System	156.0	67.5	223.5
06.1.9	Propellant	0.0	0.0	0.0
	<b>Subtotal</b>	<b>586.4</b>	<b>241.6</b>	<b>828.0</b>
	IACO	41.6	12.6	54.1
	STO	37.7		37.7
	GSE Hardware	77.0		77.0
	SE&I	109.9	35.6	145.5
	PM	42.5	18.3	60.8
	LOOS	40.6		40.6
	<b>Spacecraft Total (with Integration)</b>	<b>935.7</b>	<b>308.0</b>	<b>1243.7</b>
	Prime Contractor Fee (10% less payload)	87.1	28.0	115.1
	<b>Spacecraft Total with Fee</b>	<b>1022.7</b>	<b>336.0</b>	<b>1358.7</b>

**Figure 16.** Cost estimate for the Prime Contractor (including fee) in FY'12 \$.

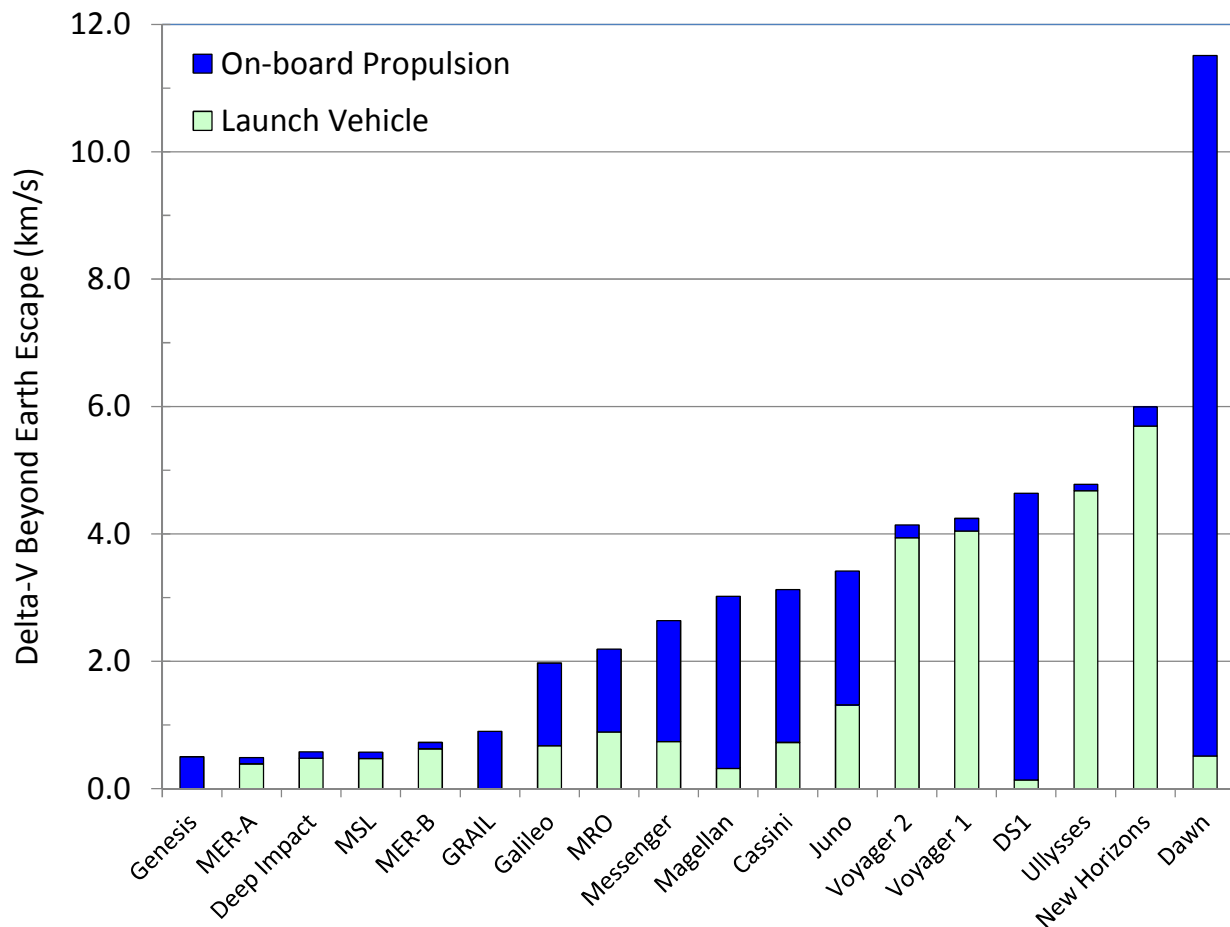


	<u>FY12\$M</u>	
NASA insight/oversight	204	15% of prime contractor costs
Phase A	68	5% of B/C/D costs
Spacecraft	1359	Prime Contractor B/C/D cost plus fee (10% - less science payload)
Launch Vehicle	288	Atlas 551
Mission Ops/GDS	117	10 year mission plus set-up
Reserves	611	30% reserves
<b>Total</b>	<b>2647</b>	

**Figure 17.** Total cost estimate for the Asteroid Capture and Return mission concept.

## VII. SEP TECHNOLOGY STATUS AND REQUIRED DEVELOPMENT

Affordable, high-performance, deep-space propulsion technology is essential for the ACR mission concept. Solar electric propulsion is the most cost-effective technology in existence for providing substantial post-launch propulsion capability in deep space. A comparison of on-board propulsion capability for 18 deep-space missions is shown in Fig. 18. This figure shows the propulsion provided beyond that required for Earth escape by the launch vehicle (shown in green) and the on-board propulsion system (shown in blue). The  $\Delta V$  provided by gravity assists is not included in Fig. 18. The two missions with the largest on-board propulsion  $\Delta V$  by far are the two that used SEP, i.e., Deep Space 1 (DS1) and Dawn. The Dawn SEP subsystem provides a  $\Delta V$  of nearly 11 km/s. In contrast, the largest post-launch chemical  $\Delta V$  for a deep-space mission was on Magellan, where a large solid rocket motor (a STAR-48) was used to provide a  $\Delta V$  of 2.7 km/s to perform the Venus orbit insertion maneuver. For liquid chemical propulsion systems the largest deep-space  $\Delta V$  is the 2.4 km/s used for the Saturn orbit insertion on the Cassini mission.

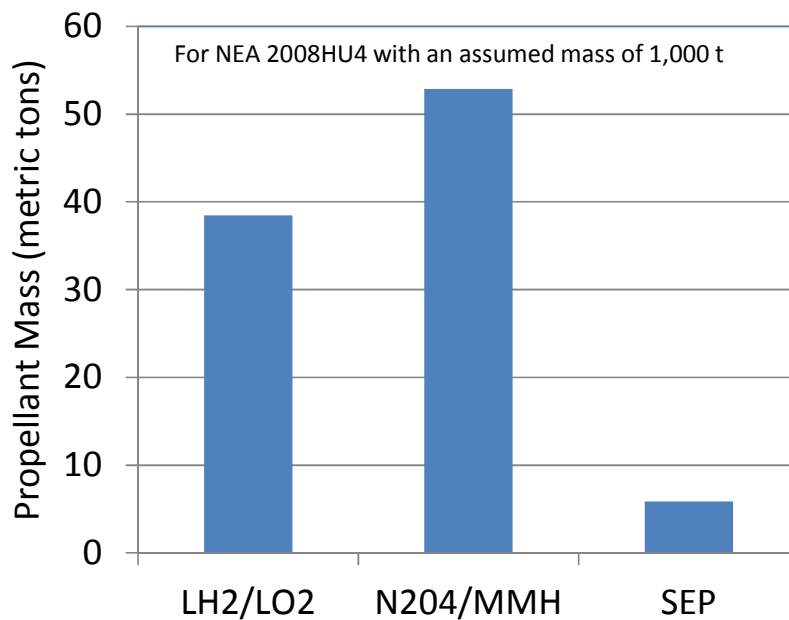


**Figure 18.** Comparison of post-Earth escape  $\Delta V$ s for 18 deep space missions indicating that by far the greatest on-board propulsion capability is provided by the solar electric propulsion technologies used on DS1 and Dawn.

For the proof-of-concept low-thrust trajectories described above based on asteroid 2008HU4, the  $\Delta V$  required to move the asteroid to lunar orbit would be only approximately 170 m/s. The large asteroid mass, however, would result in a substantial required total impulse. If we assume that 2008HU4 has a mass of 1000 t, and our spacecraft has a dry mass of 5.5 t, then from the rocket equation we get the

required propellant masses shown in Fig. 19 for three different propulsion options: LOX/LH2 with an *Isp* of 450 s; a space-storable bi-propellant system with an *Isp* of 325 s; and an SEP system with an *Isp* of 3,000 s. This figure shows only the propellant mass required for the return leg of the mission. It does not include the propellant mass required to deliver the return propellant to the NEA. The space-storable chemical propulsion system would require over 50 t of propellant to transport the NEA to lunar orbit. Even the best chemical propulsion technology, LOX/LH2, would require nearly 40 t of propellant at the NEA. Significantly more propellant, of course, is required to deliver this propellant mass to the NEA. The SEP system, on the other hand would require just under 6 t of xenon propellant at the NEA, which would enable a single EELV launch.

The basic ACR mission requires an SEP technology characterized by an end-of-life power level of order 40 kW, a Hall thruster technology capable of operating at a specific impulse of 3,000 s, and lightweight propellant tanks capable of storing up to 12,000 kg of xenon. The current state-of-the-art for these technologies and prospects for maturing them to the levels required for the ACR mission are described below.



**Figure 19.** The estimated propellant mass required to return a 1000-t NEA to lunar orbit would be prohibitive without solar electric propulsion (SEP).

### Solar Array Technology

The current state of the art for solar array technology is probably best represented by the solar arrays in use on the largest commercial communication satellites. These satellites use rigid-panel arrays with triple-junction cells and beginning-of-life (BOL) power levels up to 24 kW. At least one commercial satellite manufacturer is now offering a 30-kW BOL capability. A typical rigid-panel solar array has a specific power of approximately 80 W/kg.

The alternative to rigid-panel solar arrays are flexible-blanket arrays. Flexible-blanket arrays have been flown on the International Space Station (ISS) in a rectangular configuration with 12% efficient single-junction solar cells giving a specific power of about 40 W/kg, and on the Phoenix mission in the circular Ultraflex [37] configuration with 27% efficient solar cells resulting in a specific power of about 110 W/kg.

The ACR flight system concept described above assumes the use of a flexible blanket solar array in the Ultraflex configuration with 33% efficient IMM cells. The BOL specific power, however, would be a conservative 73 W/kg, because this includes 500-micron thick cover glass on the front and back of the

cells to reduce the radiation damage during the spiral out through the Earth's radiation belts.

Ultraflex solar arrays were scaled up by nearly an order of magnitude from 0.75 kW per wing for the Phoenix spacecraft to about 7 kW per wing for the Orion vehicle [39]. The ACR mission concept would need an additional factor of four increase in the Ultraflex solar array power to about 29 kW per wing. The circular configuration of the Ultraflex solar array means that a factor of four increase in power per wing could be achieved by increasing the wing radius by only a factor of two. The inverted metamorphic solar cells with an efficiency of 33% are expected to be flight qualified well in advance of the assumed 2020 launch date for the ACR mission.

### **Electric Propulsion Technology**

The electric propulsion technology required for the ACR mission concept has three key components: Hall thrusters capable of processing an input power of 10 kW each while producing a specific impulse of 3,000 s; Power Processing Units (PPUs) capable of providing the power necessary to operate the Hall thrusters at this specific impulse; and propellant tanks capable of storing the required xenon load with a tankage fraction of approximately 4%.

**Hall Thruster** – The state-of-the-art in Hall thruster technology is represented by the BPT-4000 thrusters that are currently flying on the Air Force Advanced Extremely High Frequency (AEHF) satellite [40]. These thrusters operate at up to 4.5 kW and a specific impulse of up to 2,000 s. Hall thrusters under development have been operated at specific impulses over 3,000 s at around 6 kW [41]. Other Hall thrusters have been designed and tested for operation at power levels of 20 kW and higher [42,43]. The thrusters are assumed to incorporate recently developed technologies which mitigate channel wall erosion so that no additional thrusters need to be added because of propellant throughput limitations [44,45]. The ACR mission concept requirements for a 10-kW, 3000-s Hall thruster represent a capability that could easily be developed.

**PPU** – The high specific impulse of 3000 s needed for the ACR mission design would require an input voltage to the Hall thruster of approximately 800 V. Voltages of this level are currently considered to be too risky for solar array operation and so direct-drive was not considered for the ACR flight system concept. Consequently, the ACR spacecraft assumes the use of a conventional PPU with an output voltage capability of 800 V and 10 kW. Hall thruster PPUs are under development that could produce the required voltage level and others that can produce the required power level. Therefore, development of a PPU with the required capability should be straight forward.

**Xenon Tank** – The ACR mission design would require the storage of about 12,000 kg of xenon. This is nearly a factor 30 greater than the 425 kg launched on the Dawn mission – the largest xenon propellant load launched to date. The Dawn xenon tank has a tankage fraction of 5% [46]. Lightweight tank technology currently under development is projected to enable a xenon tankage fraction of 3%. For the ACR mission concept we have assumed a tankage fraction of 4% as a low-risk extension of the current state-of-the-art.

### **Near-Term Application of SEP Technology for Human Missions to NEAs**

The development of a 40 kW-class SEP system would provide the valuable capability of being able to pre-deploy several tons of destination elements, logistics, and payloads. Initial estimates identify that approximately 3,100 kg of elements and logistics, along with approximately 500 kg of destination payload, could be pre-deployed in support of a human NEA mission, rather than carried with the crew. This approach would reduce the requirements for the launch vehicles and in-space propulsive elements required to conduct a human mission. The amount of mass that could be pre-deployed along with the SEP system is primarily a function of the launch vehicle utilized, the orbital energy requirements of the NEA target, the efficiency of the SEP system, and the desired amount of returned mass. Although a SEP system and associated cargo could be delivered to low-Earth orbit (LEO) by the launch vehicle and spiraled out to escape the Earth's gravity, the time required to perform this operation along with the

radiation and micrometeoroid and orbital debris (MMOD) exposure resulting from the spiral from LEO would make it desirable for the launch vehicle to be able to propel the SEP system and payload to an escape C3. Additionally, since the departure windows for accessible NEAs could be short and since it is likely that pre-deployed assets would be required to be at NEA prior to crew departure from Earth, the duration of the pre-deploy mission would be a critical factor.

Another important capability that could be leveraged is the ability to return several metric tons of asteroid samples to cislunar space and/or the possible return and reuse of mission elements. Currently, the Orion Multi-purpose Crew Vehicle (MPCV) is limited in the amount of mass it could return to the Earth's surface. The current estimate for the MPCV return capability is 100 kg of samples and associated containers. These samples would be returned to cislunar space and they could either be cached or analyzed and high-graded before the final samples were returned to Earth over some period of time. Being able to return several tons of samples would greatly increase the value of the human NEA mission, and returning critical, high-value mission elements could reduce the cost of subsequent human missions.

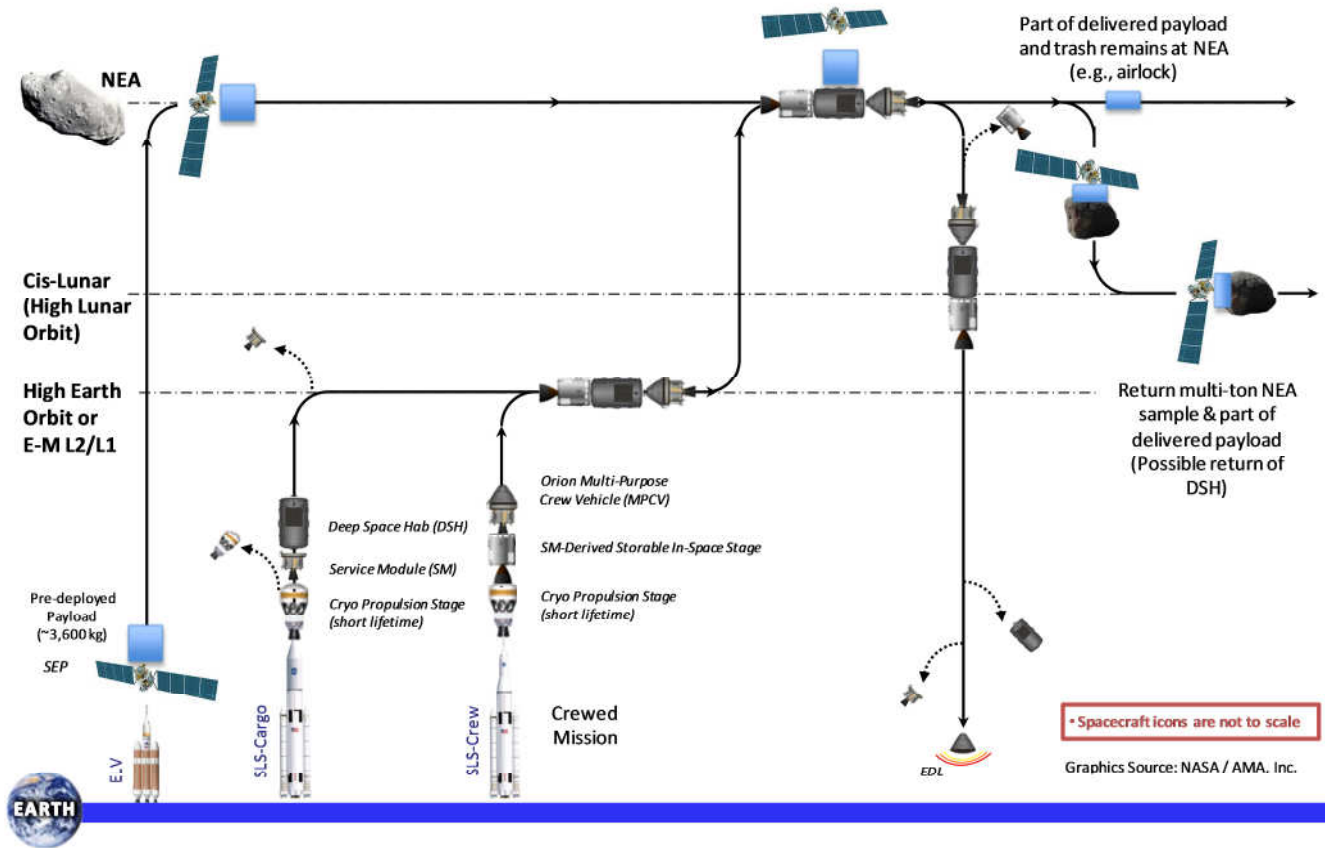
A notional concept of operations for a human NEA mission utilizing pre-deployment and providing multi-ton sample return capability is depicted in Fig. 20.

If the SEP system could deliver ~4,000 kg of payload to the target NEA for a human mission, this would likely be sufficient to provide the necessary elements and equipment to be able to utilize the SEP as an excursion vehicle (e.g., airlock, robotic arms, anchoring system, etc.) for exploring the surface of the NEA. A preliminary analysis indicates that using SEP for excursions from the mission deep space habitat to the NEA appears feasible from a daily travel time/distance standpoint, but the ability to perform local proximity operations needs further detailed analyses. A conceptual excursion spacecraft is depicted in Fig. 21. Developing confidence in the SEP system (i.e., the power and propulsive systems) could also lead to the development of higher powered SEP systems (200-300 kW-class) with greater pre-deploy and return capability which could also be used for the direct transfer of crew to and from the NEA target.

Additionally, the anchoring/capture hardware developed for the asteroid retrieval mission would provide valuable testing of the systems and the operational approaches. The SEP system could also provide resource redundancy at the destination (e.g., power and communications) during the crew mission, which could help reduce mission risk and provide additional capability at the destination.

Another important synergistic application of the SEP system would be to facilitate a multi-target robotic precursor to select the human mission NEA target(s). The SEP system could be utilized to deploy multiple independent NEA probes (rendezvous/surface) to provide reconnaissance of human targets and return a large boulder and regolith from a human target prior to conducting the human missions.

The asteroidal material delivered to cislunar space could be used to provide radiation shielding for future deep space missions and also validate in-situ resource utilization (ISRU) processes (water extraction, propellant production, etc.) that could significantly reduce the mass and propulsion requirements for a human mission. The introduction of ISRU into human mission designs could be extremely beneficial, but until the processing and storage techniques have been sufficiently tested in a relevant environment it is difficult to baseline the use of ISRU into the human mission architecture. Bringing back large quantities of asteroid materials to an advantageous location would make validation of an ISRU system significantly easier. Small asteroids could benefit the planetary defense initiatives by providing a better understanding of the nature and properties of potential Earth impactors and by facilitating the maturation of mission hardware and operational approaches. One day, in the more distant future, it is possible that a small NEA (~10 m) returned to E-M L2/L1 could act as an orbiting platform/counter weight for a lunar space elevator to allow routine access to and from the lunar surface and also function as a space resource processing facility for mining significant quantities of materials for future human space exploration and settlement and possible return and inclusion in terrestrial markets.



**Figure 20.** Notional NEA Human Mission Concept of Operations with Pre-deploy



**Figure 21.** Conceptual Human NEA Mission Excursion Vehicle Using SEP System (Image Credit: Source: NASA / AMA, Inc.)

## VIII. RECOMMENDED NEAR-TERM FOLLOW-ON ACTIVITIES

Near-term progress in the four key areas discussed below would significantly enhance the prospects of making the asteroid capture and return mission a reality.

### **Observation Campaign**

The right observation campaign is essential to discover and characterize a sufficient number of attractive NEA targets so that mission planning could be performed with confidence. An asteroid return project cannot progress very far without a robust set of target asteroids around which primary and backup opportunities could be planned. This is the most critical near-term activity and needs detailed definition study and early commencement

### **Mission Design**

The mission analysis in this report is sufficient to demonstrate the energetic and technological feasibility of capturing an asteroid and returning it to Earth. Follow-on mission analysis would look at the next level of detail down and focus on operational details, including the long-term stability of the asteroid parking orbit. Four key follow-on activities in the mission and trajectory design area are:

1. Detailed design of the Earth spiral trajectory accounting for shadowing of the solar arrays and radiation degradation of array performance.
2. Detailed design of the lunar parking orbit and characterization of stability over a period of 10-50 years.
3. Missed-thrust analysis to design return trajectories robust to thrust outages from the SEP system, and to provide assurance that no failure modes would result in Earth impact.
4. Design of transfers to and from the asteroid in its parking orbit for crewed missions based at either an Earth-Moon Lagrange point or in low-Earth orbit.

### **Capture Mechanism Development**

The capture mechanism must be able to accommodate a massive, irregularly shaped object with significant uncertainty in the physical dimensions and mass prior to launch. An over-sized inflatable structure lined with high-strength bags is the current concept for this mechanism. Development of a prototype capture mechanism based on this approach would significantly reduce risk for a future asteroid capture and return mission.

### **SEP Subsystem PPU Development**

The key feature of the SEP subsystem required for the ACR mission concept is the combination of high power (~40 kW) and high specific impulse (3,000 s). The highest risk item in the SEP subsystem is the development of a Power Processor Unit (PPU) capable of operating the Hall thruster at 10-kW and 3,000 s. Direct-drive is not a viable option for this system since it would require the development of a solar array capable of operating with a nominal output voltage of 800 V. This is considered too large a leap beyond the current state-of-the-art of 160 V. New transformerless PPU approaches may enable significant progress in the development of the required PPU for an affordable cost [47].

## IX. CONCLUSIONS

The two major conclusions from the KISS study are: 1) that it appears feasible to identify, capture and return an entire ~7-m diameter, ~500,000-kg near-Earth asteroid to a high lunar orbit using technology that is or could be available in this decade, and 2) that such an endeavor may be essential technically and programmatically for the success of both near-term and long-term human exploration beyond low-Earth orbit. One of the key challenges – the discovery and characterization of a sufficiently large number of small asteroids of the right type, size, spin state and orbital characteristics – could be addressed by a low-cost, ground-based observation campaign identified in the study. To be an attractive target for return the asteroid must be a C-type approximately 7 m in diameter, have a synodic period of approximately 10 years, and require a  $\Delta V$  for return of less than ~200 m/s. Implementation of the observation campaign could enable the discovery of a few thousand small asteroids per year and the characterization of a fraction of these resulting in a likelihood of finding about five good targets per year that meet the criteria for return.

Proof-of-concept trajectory analysis based on asteroid 2008 HU4 (which is approximately the right size, but of an unknown spectral type) suggest that a robotic spacecraft with a 40-kW solar electric propulsion system could return this asteroid to a high-lunar orbit in a total flight time of 6 to 10 years assuming the asteroid has a mass in the range of 250,000 to 1,000,000 kg (with the shorter flight times corresponding to the lower asteroid mass). Significantly, these proof-of-concept trajectories baseline a single Atlas V-class launch to low-Earth orbit.

The study also considered an alternative concept in which the spacecraft picks up a ~7-m diameter rock from the surface of a much larger asteroid (> 100-m diameter). The advantage of this approach is that asteroids 100-m in diameter or greater are much easier to discover and characterize. This advantage is somewhat offset by the added complexity of trying to pick up a large 7-m diameter rock from the surface, and the fact that there are far fewer 100-m class NEAs than smaller ones making it more difficult to find ones with the desired orbital characteristics. This mission approach would seek to return approximately the same mass of asteroid material – of order 500,000 kg – as the approach that returns an entire small NEA.

The proposed Asteroid Capture and Return mission would impact an impressive range of NASA interests including: the establishment of an accessible, high-value target in cislunar space; near-term operational experience with astronaut crews in the vicinity of an asteroid; a new synergy between robotic and human missions in which robotic spacecraft return resources for human exploitation and use in space; the potential to jump-start an entire industry based on *in situ* resource utilization; expansion of international cooperation in space; and planetary defense. It has the potential for cost effectively providing sufficient radiation shielding to protect astronauts from galactic cosmic rays and to provide the propellant necessary to transport the resulting shielded habitats. It would endow NASA and its partners with a new capability in deep space that hasn't been seen since Apollo. Ever since the completion of the cold-war-based Apollo program there has been no over-arching geo-political rationale for the nation's space ventures. Retrieving an asteroid for human exploration and exploitation would provide a new rationale for global achievement and inspiration. For the first time humanity would begin modification of the heavens for its benefit.



## **Acknowledgments**

The research described in this paper was sponsored by the Keck Institute for Space Studies (KISS) and was carried out in part at the Jet Propulsion Laboratory, California Institute of Technology, under a contract with the National Aeronautics and Space Administration.

The people and organizations listed on page 2 of this report participated in the KISS-sponsored study. It is their work that is summarized in this paper and the KISS study co-leads gratefully acknowledge their contributions. In addition, the Collaborative Modeling for Parametric Assessment of Space Systems (COMPASS) team at NASA GRC performed a study of the Asteroid Retrieval Mission concept resulting in a conceptual flight system configuration and mass estimate. Their work is also gratefully acknowledged by the study co-leads.

## References

1. Tsiolkovskii, K., *The Exploration of Cosmic Space by Means of Rocket Propulsion*, published in Russia, 1903.
2. Lewis, J. S., *Mining the Sky, Untold Riches from the Asteroids, Comets, and Planets*, Helix Books, 1996, ISBN 0-201-47959-1.
3. Wikipedia, Asteroids in Fiction, [http://en.wikipedia.org/wiki/Asteroids\\_in\\_fiction](http://en.wikipedia.org/wiki/Asteroids_in_fiction)
4. Brophy, J. R., Gershman R., Landau, D., Yeomans, D., Polk, J., Porter, C., Williams, W., Allen, C., and Asphaug, E., "Asteroid Return Mission Feasibility Study," AIAA-2011-5665, 47th AIAA/ASME/SAE/ASEE Joint Propulsion Conference and Exhibit, San Diego, California, July 31-3, 2011.
5. Keck Institute for Space Studies, <http://www.kiss.caltech.edu/>
6. OSIRIS-REx Mission, <http://www.nasa.gov/topics/solarsystem/features/osiris-rex.html>
7. International Space Exploration Coordination Group, at <http://www.globalspaceexploration.org/>.
8. Committee on the Peaceful Uses of Outer Space: Draft report of the Working Group on Near-Earth Objects (Doc.A/AC.105/C.1/NEO/2012/L.1). Feb. 2012. at [http://www.oosa.unvienna.org/pdf/limited/c1/AC105\\_C1\\_NEO\\_2012\\_L01E.pdf](http://www.oosa.unvienna.org/pdf/limited/c1/AC105_C1_NEO_2012_L01E.pdf).
9. Jones, T.D., et al. Report of the NASA Advisory Council Ad Hoc Task Force on Planetary Defense. NASA: Washington, DC. October 6, 2010. at [http://www.nasa.gov/pdf/490945main\\_10-10\\_TFPD.pdf](http://www.nasa.gov/pdf/490945main_10-10_TFPD.pdf).
10. "Shielding Space Travelers," Eugene N. Parker, *Scientific American*, March 2006.
11. [http://en.wikipedia.org/wiki/Mond\\_process](http://en.wikipedia.org/wiki/Mond_process).
12. Lewis, op. cit., pp. 109.
13. Bottke, W.F., Jedicke, R., Morbidelli, A., Petit, J.-M., Gladman, B., 2000, Understanding the distribution of near-Earth asteroids, *Science* 288, 2190-2194.
14. Britt, D.T., Yeomans, D., Housen, K., Consolmagno, G., "Asteroid Density, Porosity, and Structure," in *Asteroids III*, by William F. Bottke Jr., Alberto Cellino, Paolo Paolicchi, and Richard P. Binzel (Eds), The University of Arizona Press, 2002, pp.485-500.
15. WISE data on NEAs: Mainzer, A., and 36 colleagues, 2011, NEOWISE observations of near-Earth objects: preliminary results, *ApJ* in press, available at [arxiv.org/abs/1109.6400](http://arxiv.org/abs/1109.6400).
16. Larson, S., Brownlee, J., Hergenrother, C., Spahr, T., 1998, The Catalina Sky Survey for NEOs, *Bull.Am.Ast.Soc.* 30, 1037.
17. Jedicke, R., Magnier, E.A., Kaiser, N., Chambers, K.C., 2006, The next decade of solar system discovery with Pan-STARRS, *IAU Proceedings No. 236*, 341-352.
18. Jones, R.L., Chesley, S.R., Connolly, A.J., Harriws, A.W., Ivezić, Z., Knežević, Z., Kubica, J., Milani, A., Trilling, D.E., and the LSST Solar System Science Collaboration, 2009, *Earth Moon & Planets* 105, 101-105.
19. Thomas, C.A., and 18 colleagues, 2011, ExploreNEOs. V. Average albedo by taxonomic complex in the near-Earth asteroid population, *AJ* 142, 85.
20. Jenniskens, P., and 34 colleagues, 2009, The impact and recovery of asteroid 2008 TC3, *Nature* 458, 485-488 and Chesley, S., Chodas, P., Yeomans, D., 2008, Asteroid 2008 TC3 Strikes Earth, NASA statement, November 4 2008, available online at <http://neo.jpl.nasa.gov/news/2008tc3.htm>.
21. Pravec, P., and 19 colleagues, 2005, Tumbling asteroids, *Icarus* 173, 108-131.
22. Bus, S.J., Vilas, F., Barucci, M.A., 2002, Visible-wavelength spectroscopy of asteroids, *Asteroids III*, 169-182.
23. Britt, D.T., Yeomans, D., Housen, K., Consolmagno, G., 2002, Asteroid density, porosity, and structure, *Asteroids III*, 485-500.
24. Gaffey, M.J., Cloutis, E.A., Kelley, M.S., Reed, K.L., 2002, Mineralogy of Asteroids, *Asteroids III*, 183-204.
25. Masiero, J.R., and 17 colleagues, 2011, Main belt asteroids with WISE/NEOWISE. I. Preliminary albedos and diameters, *Astrophysical Journal* 741, 68.
26. Taylor, P.A., and 7 colleagues, 2009, Variability of thermal infrared emission from near-Earth asteroids, *Am.Ast.Soc. DPS meeting #41*, 32.01.
27. Slade, M.A, Lee, C.G., Jao, J.S., Benner, L.A.M., Brozovic, M., Giorgini, J.D., Busch, M.W., 2010, First results of the new Goldstone delay-Doppler radar chirp imaging system, *Bull.Am.Ast.Soc.* 42, 1080.
28. Ostro, S.J., Giorgini, J.D., 2004, The role of radar in predicting and preventing asteroid and comet collisions with Earth, in *Mitigation of hazardous comets and asteroids*, Belton, M.J.S. editor, 38-65.
29. Ostro, S.J., et al., 2006, Radar imaging of binary near-Earth asteroid (66391) 1999 KW4, *Science* 314, 1276-1280; Naidu, S.P. et al., 2011, Binary near-Earth asteroid 2000 DP107, *EPSC Abstracts* 6, EPSC-DPS2011-310-1.
30. Bottke, W.F., et al., 2006, The Yarkovsky and YORP effects: implications for asteroid dynamics, *Ann. Rev. Earth Planet. Sci.* 34, 157-191.
31. Chesley, S.R., et al., 2003, Direct detection of the Yarkovsky effect by radar ranging to asteroid 6489 Golevka, *Science* 302, 1739-1742.
32. Bottke et al, 2002.
33. *Icarus* 156, 399-433.
34. Law, N.M., and 40 colleagues, 2009, The Palomar Transient Factory: system overview, *Proc. Ast. Soc. Pacific* 121,

1395-1408.

35. Vilas, F., 1994.
36. Icarus 111, 456-467.
37. Spence, B., et al., "Next Generation Ultraflex Solar Array for NASA's New Millennium Program Space Technology 8, 2005 IEEE Conference.
38. C. Ocampo and J. Senent. The Design and Development of Copernicus: A Comprehensive Trajectory Design and Optimization System. In Proceedings of the International Astronautical Congress, IAC-06-C1.4.04, 2006."
39. Orion spacecraft. [http://en.wikipedia.org/wiki/Orion\\_\(spacecraft\)](http://en.wikipedia.org/wiki/Orion_(spacecraft)).
40. AEHF Satellite with Hall thrusters. [http://www.aerojet.com/news\\_p.php?action=fullnews&id=257](http://www.aerojet.com/news_p.php?action=fullnews&id=257).
41. Mikellides, I.G., Katz, I., and Hofer, R.R., "Design of a Laboratory Hall Thruster with Magnetically Shielded Channel Walls, Phase I: Numerical Simulations," AIAA 2011-5809, presented at the 47 AIAA/ASME/SAE/ASEE Joint Propulsion Conference, 31 July – 03 August, 2011, San Diego, CA.
42. Kamhawi, H., Haag, T.W., Jacobson, D.T., and Manzella, D.H., "Performance Evaluation of the NASA-300M 20-kW Hall Effect Thruster," AIAA 2011-5521, presented at the 47 AIAA/ASME/SAE/ASEE Joint Propulsion Conference, 31 July – 03 August, 2011, San Diego, CA.
43. Manzella, D., Jankovsky, R., and Hofer, R., "Laboratory Model 50 kW Hall Thruster," presented at the 38<sup>th</sup> AIAA/ASME/SAE/ASEE Joint Propulsion Conference, 7-10 July 2002, Indianapolis, Indiana.
44. De Grys, K. H., Mathers, A., Welander, B., and Khayms, V., "Demonstration of 10,400 Hours of Operation on 4.5 kW Qualification Model Hall Thruster," AIAA Paper 2010-6698, July 2010.
45. Mikellides, I. G., Katz, I., Hofer, R. R., Goebel, D. M., De Grys, K. H., and Mathers, A., "Magnetic Shielding of the Acceleration Channel in a Long-Life Hall Thruster," Physics of Plasmas 18, 033501 (2011).
46. Brophy, J.R., "The Dawn Ion Propulsion System," Space Science Reviews, Volume 163, Issue 1 (2011), Page 251-261.
47. C. Stell, Jet Propulsion Laboratory, personal communication.