

# INSTRUMENTS AND METHODS

## PORTABLE THERMAL CORE DRILL FOR TEMPERATE GLACIERS\*

By R. L. SHREVE

(University of California, Los Angeles, California, U.S.A.)

and W. B. KAMB

(California Institute of Technology, Pasadena, California, U.S.A.)

**ABSTRACT.** In the summer of 1962 a completely portable and relatively simple electrically heated thermal core drill of new design was constructed and used to obtain 16 oriented samples of ice 2.5 cm. in diameter by 120 cm. in length from depths ranging from 12 m. to 137 m. in lower Blue Glacier, Mount Olympus, Washington, U.S.A. The thermal element is a 0.260-in. (0.66-cm.) diameter 300-W. 150-V. tubular heater bent to form an annulus with an external diameter of 5.0 cm. Opposed ratchet-like teeth break off and hold the core inside the tubular core barrel. Orientation is recorded photographically by a commercial inclinometer modified to show azimuth and to be controlled from the surface.

**RÉSUMÉ.** Durant l'été 1962 un carotteur thermique électrique entièrement portatif, relativement simple et de conception nouvelle, a été construit. On l'a utilisé pour obtenir 16 échantillons de glace orientée ayant 2,5 cm de diamètre et 120 cm de longueur pour des profondeurs allant de 12 à 137 mètres dans la partie inférieure du Blue Glacier, Mount Olympus, Washington, U.S.A. L'élément thermique (300 W, 150 V) tubulaire de diamètre 0,66 cm, a été courbé pour former un anneau de diamètre externe de 5 cm. Des encliquetages à dents opposés, détachent et tiennent l'échantillon à l'intérieur du tube carottier. On enregistre photographiquement l'orientation à l'aide d'un inclinomètre commercial modifié de façon à donner l'azimut et à être contrôlé à partir de la surface.

**ZUSAMMENFASSUNG.** Im Sommer 1962 wurde nach neuen Entwürfen ein tragbarer und relativ einfacher thermischer Kernbohrer mit elektrischer Beheizung gebaut. Damit wurden 16 orientierte Eisproben mit einem Durchmesser von 2,5 cm und einer Länge von 120 cm aus Tiefen zwischen 12 m und 137 m im unteren Blue Glacier am Mt. Olympus, Washington, USA, erbohrt. Das thermische Element ist ein röhrenförmiger Heizkörper von 0,66 cm Durchmesser mit 300 W Leistung bei 150 Volt, der so gebogen ist, dass er einen Ring mit 5,0 cm Aussendurchmesser bildet. Gegenständige Sperrzähne brechen den Kern ab und halten ihn im Inneren des Rohrgehäuses fest. Die Orientierung wird photographisch mit einem handelsüblichen Inclinometer festgehalten, das so abgeändert wurde, dass es auch das Azimut anzeigen und von der Oberfläche aus bedient werden kann.

### INTRODUCTION

Core drilling to obtain samples from deep within glaciers is a logical adjunct to study of the ice at the surface. It makes possible, for example, investigation of glacier structure in three dimensions, mapping of structure and other features under permanent snow cover, measurement of texture and fabric of temperate glacier ice that has undergone rapid deformation without subsequent annealing, and analysis of oxygen-isotope ratios and of entrained matter, such as gases, pollen grains, and rock particles, in the ice at depth.

Samples have been obtained from a depth of several hundred meters in the cold, dry polar ice of Greenland and Antarctica, by both mechanical and thermal core drilling (Langway, 1958, p. 337; Patenaude and others, 1959, p. 1-4; Ragle and others, 1960, p. 1-4); but, because of its great weight, bulk, and cost, the equipment required is unsuited for the not uncommon glaciological research projects in which everything must be transported on men's backs. At the opposite end of the scale of portability, the hand-operated SIPRE coring auger (Anonymous, 1957, p. 30) has been widely used with great success; but for holes deeper than a few meters, especially in water-saturated ice, the effort required for its use increases very rapidly with depth; moreover, it obtains an unoriented core. Other core drills for sampling

\* Publication No. 297 of the Institute of Geophysics, University of California, Los Angeles; Publication No. 1174 of the Division of Geological Sciences, California Institute of Technology.



glacier ice have been reported (Miller, 1951, p. 579; Schwarzacher and Untersteiner, 1953, p. 113; Ward, 1952, p. 117; 1954, p. 433); but, in general, glaciologists have rather surprisingly neglected the development of this potentially highly useful tool.

This paper describes the design and performance of a completely portable and relatively simple electrically heated thermal core drill that was employed in the summer of 1962 to

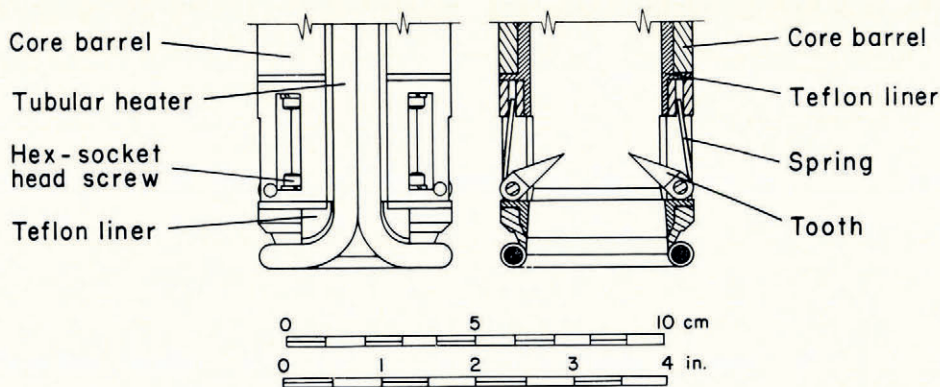

Fig. 1. Details of construction of thermal core drill. Left: Exterior. Right: Longitudinal cross-section

obtain oriented samples of ice 2.5 cm. in diameter by 120 cm. in length from depths ranging from 12 m. to 137 m. in lower Blue Glacier, Mount Olympus, Washington, U.S.A. Structure, texture, and fabric of the cores were studied; they will be discussed in a separate article (Kamb and Shreve, 1963 [a], [b]).

#### DESIGN

In addition to achieving the primary objective of obtaining, from depths as great as 300 m. in temperate ice, oriented samples big enough to permit measurement of foliation, texture, and fabric with statistical assurance, the design of the core drill had to satisfy a number of secondary conditions. The core drill had to be as simple, and use as many existing or ready-made components as possible. It had to operate on the power supplied by an existing 2,500-W. 230/115-V. portable powerplant. It could be no more than 5.0 cm. in diameter, so that it could pass through holes bored with existing hotpoints which will be described in a forthcoming paper on bore-hole operations and observations on Blue Glacier, Mount Olympus, Washington, by R. L. Shreve and R. P. Sharp. Finally, it had to be rugged and capable of being transported in light ski-equipped aircraft or carried on foot over rough terrain.

The design finally developed after considerable laboratory testing and modification is shown in Figures 1 and 2. Thermal drilling was chosen for its simplicity and its proven effectiveness in water-saturated ice, and to facilitate getting oriented cores. The thermal element is made from a 0.260-in. (0.66-cm.) diameter 300-W. 150-V. General Electric "Calrod" tubular heater with stainless steel jacket bent to the desired shape. The ends of the heater are sealed with ceramic plugs cemented with a hard, heat-resistant epoxy resin and coated with synthetic rubber. The finished element has high mechanical strength and long operating life, and can withstand temporary operation out of water. The thermal element is mounted on the lower end of the core barrel, a piece of stainless steel tubing (5.0 cm. external diameter, 4.1 cm. internal diameter) 120 cm. long which receives the core as the drill penetrates the ice.



A major difficulty in developing the core drill was to prevent melting of the newly formed core by hot water convected up into the core barrel from the thermal element. This was solved by the teflon (polytetrafluorethylene) liner, which both inhibits convection in the lower end of the core barrel and impedes conduction from the core barrel to the water inside. The liner causes the water on the outside to be warmer than that on the inside. This effect

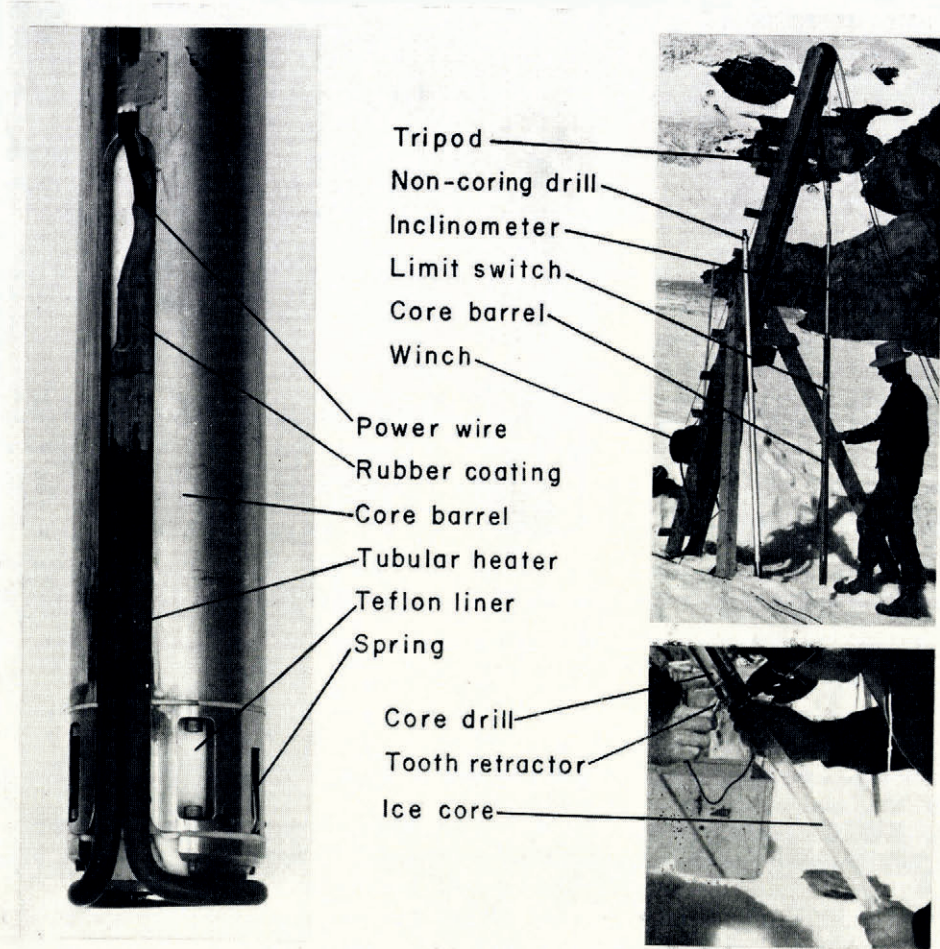

Fig. 2. Portable thermal core drill. Left: Thermal element and lower end of core barrel. Photograph by L. Weymouth. Upper right: General arrangement of core drill and surface equipment. Photograph by R. L. Shreve. Lower right: Removal of core. Photograph by J. M. Shreve

was utilized to minimize melting even further; a large hole in the upper end of the core barrel allows a convection cell to develop in which warm water flows up the outside and cool water down the inside.

As the core enters the core barrel, it passes between a pair of opposed ratchetlike stainless steel teeth that permit it to move upward but not downward. When the core drill is raised, the teeth, whose sharp points quickly pressure-melt into the ice when drilling stops, penetrate the core and break it off. To release the core after it is brought to the surface, the teeth are retracted by means of a pair of hand-held hooks made of heavy music wire.



A sliding cylindrical weight inside the core barrel rests on top of the core and holds it down on the teeth to preserve its orientation relative to the drill. Though successfully used, this system presents practical difficulties in operation, especially if the core is broken, as is often the case. Ideally, the drill should make a narrow groove or other permanent mark of known orientation running the full length of the core, but a practical method for doing so was not found, despite a considerable amount of experimentation.

Mounted on the upper end of the core barrel is a limit switch assembly consisting of a mercury switch that shunts a 200- $\Omega$  200-W. wire wound resistor across the thermal element when the core barrel is full. It is designed to operate properly even if the axis of the core drill is tilted as much as 40 degrees from the vertical in any direction. The resultant increase in current serves as a signal that drilling is completed.

Located just above the limit switch assembly is a Parsons single-shot inclinometer that records photographically the positions of a compass needle, a pendulum, and, as modified for the core drill, an azimuthal mark indicating orientation of the core barrel. The inclinometer is also modified to operate on electric current supplied and manually controlled from the surface, rather than with the regular internal batteries and timer, thus assuring a good record every time and permitting measurement of orientation after drilling is complete. The inclinometer is capable of measuring azimuths to within 2 degrees and inclinations up to 4 degrees from the vertical to within 0.1 degrees. With shorter pendulums it can measure inclinations up to 27 degrees with the same relative accuracy.

The core drill (20 kg.) is attached to a 0.32 cm. diameter galvanized steel aircraft cable 300 m. long (14 kg.) which is raised and lowered by a hand-cranked winch (32 kg.) mounted on a wooden tripod (100 kg., can be disassembled). Current for the inclinometer is carried by a two-conductor rubber-covered cable (15 kg.). Power for the core drill is supplied by a commercial portable 2,500-W. 230/115-V. 60-cycle generator driven by an integrally mounted two-cycle gasoline engine (55 kg.) and is transmitted to the drill by two single-conductor rubber-covered cables (25 kg. each).

#### PERFORMANCE

In late August 1962 the core drill was set up beside a crevasse on Blue Glacier, Mount Olympus, Washington, U.S.A., from which samples at a few meters depth could be obtained with pick and saw, and was used to drill a vertical hole 5 m. deep, from which four cores 2.5 cm. in diameter by 120 cm. in length were obtained. The three primary objectives of drilling this preliminary hole were (1) to find the best operating routine, (2) to develop a system for preserving the orientation of the cores during handling, and (3) to verify that the structure, texture, and fabric of the cores are unaffected by thermal drilling.

At a depth of 5 m. the drill penetrated the crevasse, allowing the water to drain from the hole. The resultant over-heating did not affect the thermal element, which was operating at rated power, 300 W., but it did cause warping and partial destruction of the teflon liner, which had to be replaced.

In early September the core drill was moved to another site; and a hole 137 m. deep was drilled, reaching the bed of the glacier. With a power input of 300 W. the core drill penetrated the ice at 1.2 m. hr.<sup>-1</sup>; it was used alternately with a non-coring thermal drill whose speed was about 8 m. hr.<sup>-1</sup>. The hole drilled was about 5.5 cm. in diameter, and remained within one degree of vertical at all depths.

No special operating difficulties were experienced, although great care had to be exercised to prevent jamming of the four cables in the hole. For safest operation the weight of the core drill should exceed the combined weight of the cables as much as possible. Sixteen cores were obtained, fourteen of them oriented. The two failures were due to lack of emulsion on an inclinometer record and to operator error respectively. Most of the cores were somewhat



elliptical in cross section, and showed irregular variations in diameter probably attributable to fluctuations in efficiency of drilling. Many of the cores were broken into 2, 3, or 4 pieces, which nearly always could be unambiguously fitted together. Modification of the operating procedure to minimize disturbance of the drill during coring noticeably diminished, but did not eliminate, breakage. Increasing the internal diameter of the core barrel, to increase clearance around the core, and insulating the bottom of the sliding weight, to prevent pressure-melting and wedging of the core, might further decrease breakage, but unfortunately could not be tried. Finally, it is possible that cores brought suddenly from depth in a glacier will break spontaneously regardless of how gently they are handled, so that no change in equipment or procedure would be entirely successful.

#### ACKNOWLEDGEMENTS

This work is part of the lower Blue Glacier research program directed by Professor R. P. Sharp of the California Institute of Technology. It was supported by the National Science Foundation (Grant G17688) and by the University of California (Grant No. 1694). The National Park Service graciously gave permission for the field tests, and personnel of Olympic National Park aided the project in numerous ways. Mr. William R. Fairchild, of the Angeles Flying Service, Port Angeles, Washington, provided logistical support. Mr. William Parsons, of the Parsons Survey Company, South Gate, California, kindly supplied the inclinometer, modified it to record azimuth, and provided vital consultation on the other changes required. Professor C. R. Allen and Mr. Curtis Bauman contributed generously to the success of the core drill, both in the laboratory and on the glacier; their invaluable assistance is warmly appreciated.

*MS. received 16 July 1963*

#### REFERENCES

- Anonymous. 1957. Instruments and methods: Ice drills and corers. *Journal of Glaciology*, Vol. 3, No. 21, p. 30.
- Kamb, W. B., and Shreve, R. L. 1963[a]. Structure of ice at depth in a temperate glacier. *Transactions. American Geophysical Union*, Vol. 44, No. 1, p. 103. [Abstract.]
- Kamb, W. B., and Shreve, R. L. 1963[b]. Texture and fabric of ice at depth in a temperate glacier. *Transactions. American Geophysical Union*, Vol. 44, No. 1, p. 103. [Abstract.]
- Langway, C. C., jr. 1958. Bubble pressures in Greenland glacier ice. *Union Géodésique et Géophysique Internationale. Association Internationale d'Hydrologie Scientifique. Symposium de Chamonix, 16-24 sept. 1958*, p. 336-49.
- Miller, M. M. 1951. Instruments and methods: Englacial investigations related to core drilling on the upper Taku Glacier, Alaska. *Journal of Glaciology*, Vol. 1, No. 10, p. 579-80.
- Patenaude, R. W., and others. 1959. Deep core drilling in ice, Byrd station, Antarctica, by R. W. Patenaude, E. W. Marshall and A. J. Gow. *U.S. Snow, Ice and Permafrost Research Establishment. Technical Report 60*.
- Ragle, R. H., and others. 1960. Deep core drilling in the Ross Ice Shelf, Little America V, Antarctica, by R. H. Ragle, B. L. Hansen, A. J. Gow and R. W. Patenaude. *U.S. Snow, Ice and Permafrost Research Establishment. Technical Report 70*.
- Schwarzacher, W., and Untersteiner, N. 1953. Zum Problem der Bänderung des Gletschereises. *Sitzungsberichte der Österreichischen Akademie der Wissenschaften. Mathematisch-naturwissenschaftliche Klasse, Abt. 2a, Bd. 162*, Hft. 1-4, p. 111-45.
- Ward, W. H. 1952. The glaciological studies of the Baffin Island Expedition, 1950. Part III: equipment and techniques. *Journal of Glaciology*, Vol. 2, No. 12, p. 115-21.
- Ward, W. H. 1954. Studies in glacier physics on the Penny Ice Cap, Baffin Island, 1953. Part II: portable ice-boring equipment. *Journal of Glaciology*, Vol. 2, No. 16, p. 433-36.