

The Palomar 200-inch f/9 Cassegrain CCD camera

James K. McCarthy

Palomar Observatory, California Institute of Technology
Pasadena, CA 91125

ABSTRACT

This article describes the design and construction of a CCD camera for the f/9 Cassegrain focus of the 200-inch (5 m) Hale Telescope at Palomar Observatory. This instrument utilizes a set of 18-inch (0.45 m) diameter lenses to change the Cassegrain focal ratio from f/16 to f/9, and the optical design prescription of these lenses is reported. For CCDs having $24\mu\text{m}$ pixels, the f/9 focus gives a reciprocal plate scale of 9 pixels per arcsecond, which is well suited to precision photometry as well as future application to adaptive optics. In addition to the CCD and shutter, the instrument also incorporates an offset guider and an 8-position filter wheel.

1 SCIENTIFIC MOTIVATION

The standard f/16 Cassegrain of the Palomar 200-inch Hale Telescope has a plate scale of 2.54 arcseconds/mm, or 0.061 arcseconds/pixel for CCD pixels measuring $24\mu\text{m}$. It is therefore poorly matched to CCD imaging observations in the absence of any reimaging optics. For a Tektronix CCD containing 1024^2 pixels, this 16 pixels/arcsecond reciprocal scale provides a total field of about 1-arcminute. In order to maximize the imaged field size, most existing CCD imaging instruments at Palomar (*e.g.*, the PFUEI¹ and COSMIC² Prime focus instruments, as well as the 4-SHOOTER³ at the f/16 Cassegrain focus) have been designed with reciprocal plate scales of approximately 3 pixels/arcsecond. For most applications these instruments quite adequately sample the typical 1-arcsecond seeing disk diameter.

To facilitate an observing program⁴ in which very precise time series photometry was required over a minimum field size of 90 arcseconds with a target image scale of 0.2 arcseconds/pixel or less, a new CCD imaging instrument was designed and constructed for the f/9 Cassegrain focus of the Hale Telescope. With a 1024×1024 CCD array of $24\mu\text{m}$ pixels, the f/9 focus provides a nearly 2-arcminute field of view at an image scale of 0.11 arcsec/pixel (or 9 pixels/arcsec). An increased number of pixels per arcsecond permits CCD photometry to achieve a greater S/N ratio in a single

exposure prior to saturation, an indeed increases the photometric accuracy achieved for the same stellar signal in the high S/N regime — where CCD readnoise is insignificant — by increasing the number of pixels included in the flat field for each star. These two advantages were both crucial to the planned observing program, in which solar-type oscillations in the stars of M67 were to be investigated photometrically, requiring an accuracy per exposure of order 300 μ mag and an ultimate sensitivity for a 7-night time series of 20 μ mag or better.

2 THE OPTICAL DESIGN

The f/9 Cassegrain focus is produced by an 18-inch (0.45 m) diameter doublet or triplet lens system (depending upon the wavelength range of the observation; work in the red requiring the triplet configuration) located above the Cassegrain focus in the converging beam from the f/16 secondary mirror. These lenses were designed in the early 1960s by Ira S. Bowen at Caltech, and were fabricated in 1963. Table 1 gives a complete optical prescription for these lenses, in the triplet configuration used in the red ($\lambda \geq 5500 \text{ \AA}$), from a Code V raytrace conducted in the course of this work. For work at shorter wavelengths, only the K7/F2 doublet is used: surfaces numbered 7 and 8 in Table 1 are eliminated, thickness 6 becomes 38.691 inches, and the telescope secondary mirror focus must be changed so that thicknesses 1 and 2 become $- / + 538.836$ inches.

Table 1: Optical Design Prescription for the 200-inch f/9 Cassegrain

Surface No.	Radius (in.)	Thickness (in.)	Material	Notes
1	-1335.700	-539.165	Reflection	Primary mirror ($k = -1.0000$)
2	-325.465	539.165	Reflection	f/16 secondary ($k = -2.3177$)
3	0.000	10.219	Airspace	f/9 lenses fixed below primary
4	58.583	2.283	Schott K7	
5	-36.299	0.433	Schott F2	
6	-120.078	0.197	Airspace	
7	103.937	0.394	Schott F2	Optional (red) lens element
8	80.315	38.100	Airspace	To underside of f/9 mounting plate
9	0.000	0.043	Airspace	Dewar window recess
10	0.000	0.125	Fused Silica	CCD Dewar window
11	0.000	0.535	Vacuum	CCD depth inside Dewar
12	0.000	0.000	Focal Plane	CCD Location

A cross-sectional view of the three f/9 lenses is shown in Figure 1; note the manner in which the third element, the red meniscus lens, can be moved out of the beam for work at wavelengths less than 5500 \AA . Together with the 200-inch primary and f/16 secondary mirrors, the 18-inch diameter f/9 lenses produce an unvignetted field of view 7.5 inches (14 arcminutes) in diameter. The original use of the f/9 system was in conjunction with 8×10 -inch photographic plates, and it was used photographically for several years in the mid-1960s. The new instrument described in this paper represents the first application of the f/9 Cassegrain optics to modern CCD imaging.

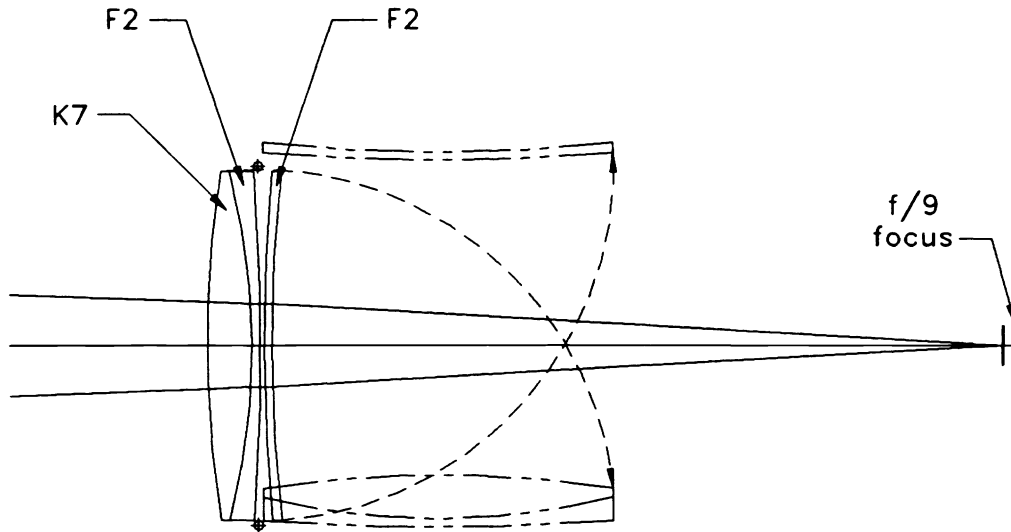

Figure 1: Cross-sectional view of the 18-inch diameter f/9 lenses.

In September 1992, the three 18-inch diameter lenses were commercially anti-reflection (AR) coated by Continental Optical (Hauppauge, NY) with high-efficiency broad-band coatings for utmost performance. Shown in Figure 2 are the reflectivity curve for each coated surface as measured from witness samples; the reflectivity from 3650 Å to 9000 Å is approximately 0.5% average per surface. The doublet lenses are joined at the common radius (R5 in Table 1) with Dow Corning Q2-3067 optical couplant ($n = 1.4648$ at $\lambda = 5890$ Å).

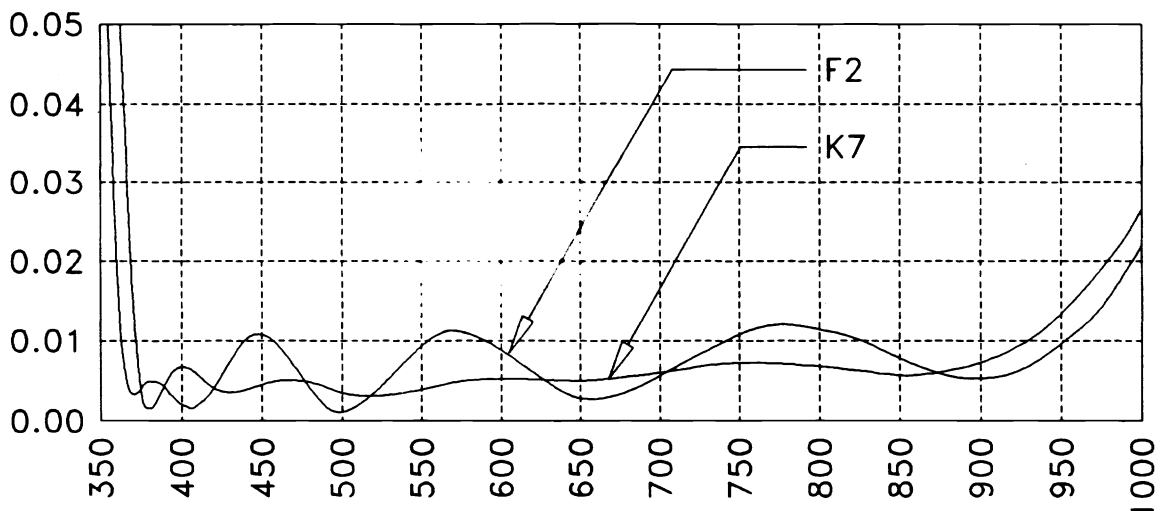

Figure 2: Reflectivity versus wavelength (nm) for the AR-coatings applied to the f/9 lenses.

Optical aberrations introduced by the lenses over the central 2.5-inch (64 mm) field available for use with CCDs in the new f/9 instrument are less than 0.1-arcseconds r.m.s. diameter at all wavelengths. In practice, therefore, it will be the atmospheric seeing and/or the figure errors of the 200-inch primary and f/16 secondary mirrors which will limit the resolution of CCD images obtained

at the f/9 focus, and not the f/9 lenses themselves. As predicted by the raytrace analysis, the image quality (*i.e.*, the point spread function) furnished by the f/9 system proves to be exceedingly uniform across the 2-arcminute field of view of the 1024×1024 CCD, and would remain so for much larger (*e.g.*, 2048×2048) CCDs as well. This is not surprising since the intended applications were to use 8×10 -inch photographic plates.

3 THE MECHANICAL DESIGN

3.1 Camera lens housing

The new f/9 instrument uses the original camera housing for the 18-inch doublet and optional third (red meniscus) lens elements. This 28.5-inch diameter housing attaches to the standard rotating Cassegrain instrument ring with four pins, and extends approximately 42-inches up inside the perforation of the primary mirror. A pair of hand-operated cranks, one for the doublet elements and another for the optional third (red meniscus) lens element, are provided at the bottom of the housing to swing into position the 18-inch diameter lenses, enabling lens configurations “f/9 blue” (doublet elements only), “f/9 red” (all three elements), or “f/16” (no lenses) to be selected easily while the unit is mounted on the telescope at the Cassegrain focus. When cranked out of the beam, the lenses are stowed in vertical positions inside the f/9 camera housing (see Figure 1). At the bottom of the housing, adjacent to the hand-operated cranks is a 20-inch diameter opening (surrounded by sixteen $5/16 - 18$ tapped holes on a 21.5-inch diameter bolt circle) where focal plane instrumentation can be attached for use at the f/9 focus.

3.2 New CCD instrument overview

Figures 3 and 4 show the mechanical design of the new 200-inch f/9 Cassegrain CCD camera instrument. Most of the moving parts are mounted to the top surface of a $36 \times 24 \times 0.75$ -inch aluminum baseplate (A), so as to function above the focus. These include a filter wheel (B1), a 64 mm diameter Prontor shutter (C), and a motorized offset TV guider ‘periscope’ (D1). Below the baseplate are located the rails to which the TV guider camera attaches (E), the CCD Dewar (F), the stepper motor which drives the filter wheel (B3), and all electrical connectors.

3.2.1 Filter wheel

The f/9 Cassegrain CCD camera instrument includes an 11-inch diameter, 8-position filter wheel (B1) with removable filter cells for standard 2×2 -inch (50 mm square) filters. The filter cell 180° opposite from that which is above the CCD detector can be removed through a 4-inch square access port in the baseplate, so that the filter cells loaded into the wheel can be exchanged while

the instrument is on the telescope. The same filter wheel will, however, also accommodate 3-inch (76 mm) diameter circular filters in an alternate filter cell design interchangeable with the standard 2 × 2-inch filter cells. The filter cells attach to the wheel with three captured screws.

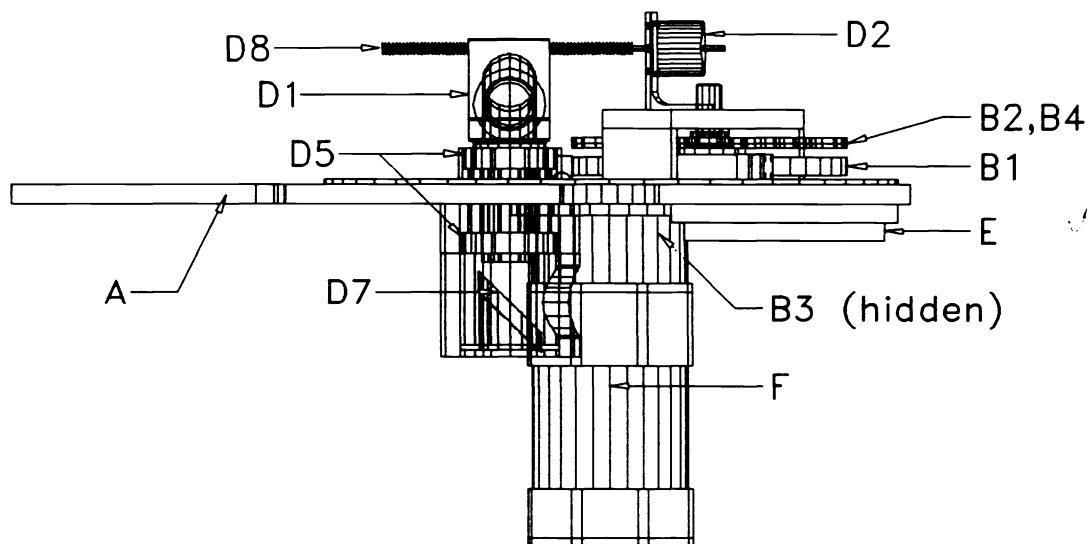

Figure 3: Side view of the f/9 instrument assembly, with the top dust cover removed.

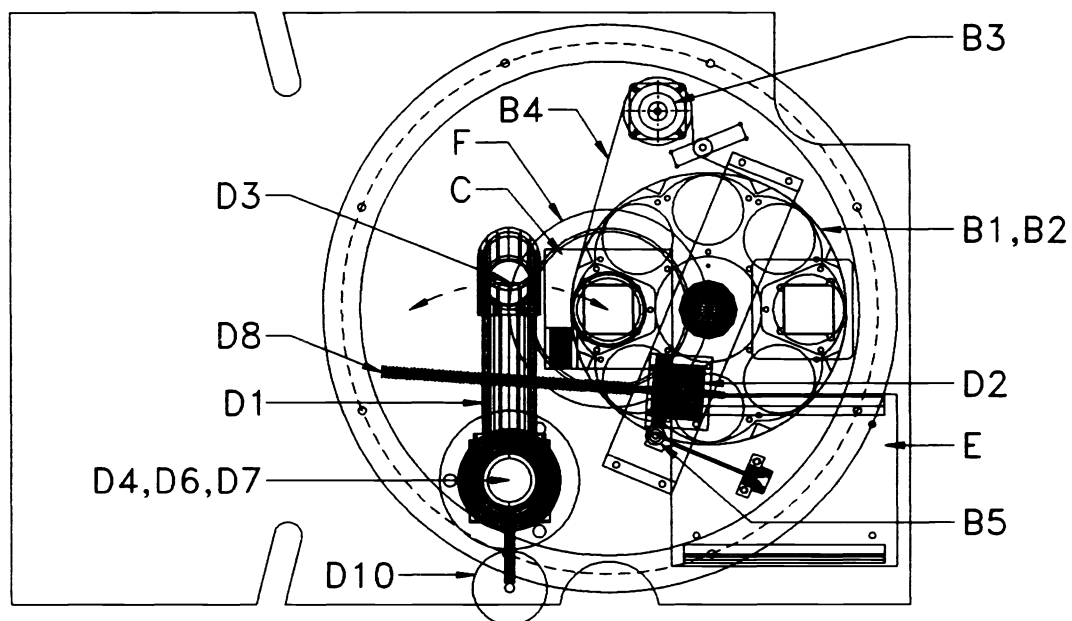

Figure 4: Top view of the f/9 instrument assembly, with the top dust cover removed.

The filter wheel is moved by a drive wheel (B2) computer driven by a stepper motor (B3) and belt (B4). A pin in the drive wheel engages an over-sized hole in the filter wheel, so that the filter wheel positions are precisely defined by a cam follower (B5, on the end of a flexible arm attached

to the baseplate) engaging detents in the filter wheel, and not by the particular stopping point of the stepper motor drive system. An infrared LED and photocell can be turned on and monitored to provide a fiducial “home” signal when holes in the drive and filter wheels line up between them. This will also initialize the filter selection software.

3.2.2 Shutter

Machined into the 0.75-inch thick instrument baseplate is a relief for a 2.5-inch (64 mm) diameter Prontor shutter (C), located immediately above the CCD detector. The normally closed shutter opens when +24 V is applied to its solenoid. The minimum open–close cycle time for the shutter is 30 msec, so that exposures of 3 seconds duration or longer will exhibit better than 1% center-to-edge uniformity in the total length of time light is admitted through the shutter.

3.2.3 Offset guider

The instrument also includes an offset TV guider ‘periscope’ (D1). The guider periscope can be stepper motor (D2) driven in the radial direction through the field, spanning a total radial offset of 0 to 14 arcminutes from the optical axis (*i.e.*, the CCD position) to pickup suitable guide stars. Only the central 7 arcminutes of radial travel is completely unvignetted by the 18-inch diameter lenses, while the innermost 4 arcminutes of motion may partially occult the f/9 beam to the CCD, depending upon its size. When the radial motion of the periscope is coupled with the rotation of the complete f/9 camera on the rotating Cassegrain ring, it is possible for the TV guider to search out an entire 28-arcminute diameter (14-arcminute diameter unvignetted) field around the target being imaged by the CCD detector.

Figure 5 details the design of the offset guider periscope. The end of the periscope carries an aluminized and overcoated 2.15-inch minor axis elliptical flat mirror (D3), held fixed at 45° to the telescope optical axis, so that light reflected off this mirror travels through the hollow arm of the periscope (D1). The converging rays which are intercepted by the pick-off mirror at the end of the periscope will form an image inside the periscope arm, 4.625 inches from the pick-off mirror. A second identical mirror (D4) is located where the arm axis intersects the axis of rotation for the periscope, and this mirror reflects light through the hollow rotation axis defined by a pair of large SKF tapered roller bearings (D5, one above and one below the 0.75-inch thick baseplate). An achromatic doublet lens (D6) is located just below the second mirror, at a distance from the interior image equal to its focal length. The lens therefore collimates the diverging rays, and it forms a pupil just beyond the end of the hollow periscope axis tube. Here a final 45° folding mirror (D7) is held stationary (*i.e.*, the third mirror does not rotate as the periscope arm scans), and directs the light which emerges from the axis tube below the baseplate to the TV guider camera optical axis (see Figures 3 and 4). Since the emerging light is collimated by the achromat inside the periscope, the TV guider camera’s lens is set to a nominal focus at infinity.

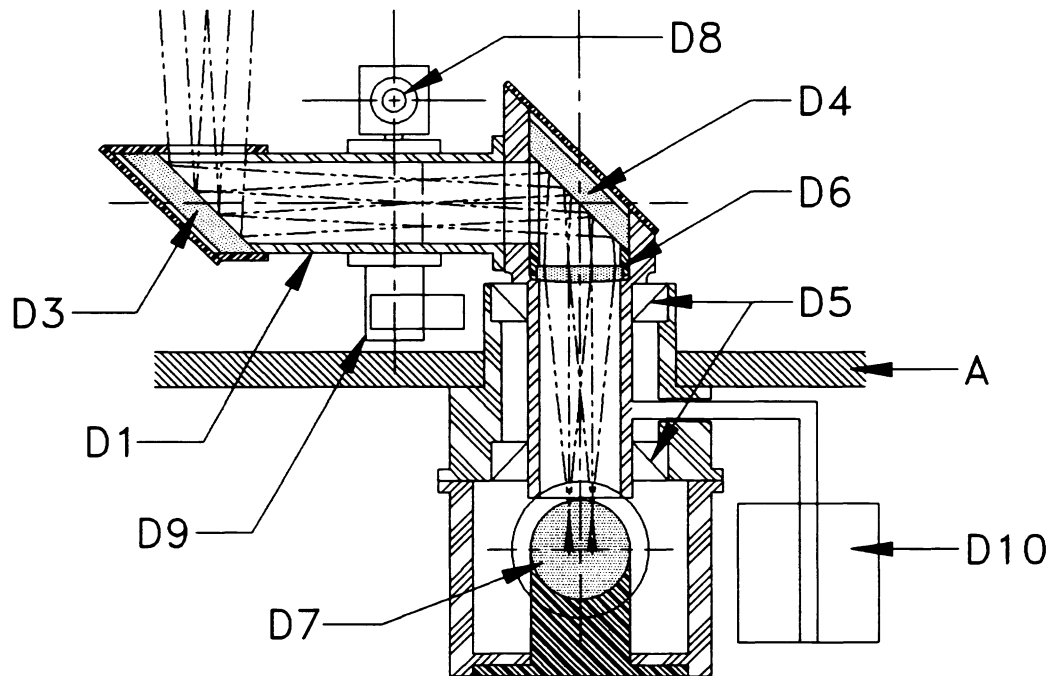

Figure 5: Detailed cross-section of TV guider periscope.

The scan motion of the TV guider periscope arm is driven by a stepper motor (D2, attached to the bracket supporting the upper end of the filter wheel axle; see Figures 3 and 4) which turns a stainless steel lead screw (D8). Mounted to the top of the periscope arm is an anti-backlash nut that engages the lead screw. Attached to the underside of the periscope arm is an aluminum 'paddle' (D9) which will strike electrical limit switches (mounted to the top surface of the baseplate) at the extremes of the scan motion. The inner extreme limit switch (with the TV guider periscope pick-off mirror intercepting the on-axis $f/9$ beam above the CCD) serves as the fiducial from which the software will reference the guider field location relative to the telescope position, given the Cassegrain ring angle. Lastly, shown at lower right in Figure 5 is a counterweight (D10) intended to balance the guider periscope about its axis of rotation. This counterweight design has yet to be implemented, but experience with the TV guider periscope to date has not indicated that any counterweight is necessary, as the imbalance is not large enough to flex or back-drive the lead screw and stepper motor.

3.2.4 Dust cover

All instrument components above the baseplate (A) are enclosed by a 20-inch diameter \times 7.0-inch tall dust cover. The bottom edge of the enclosure is attached to the inside edge of a flat 0.25-inch thick aluminum spacer ring (the large circles in Figure 4) which bolts onto the baseplate. An arc-shaped opening in the top surface of the dust cover admits light to the TV guider periscope and the CCD detector.

3.2.5 CCD Dewar mount

The standard Palomar CCD Dewars⁵ are 6.25 inches in diameter where the CCD is enclosed. Following what has become standard practice at Palomar, the CCD Dewar on the 200-inch f/9 camera is held in position by a pair of semicircular retaining rings which engage a lip, 6.50 inches in diameter \times 0.25 inches high on the edge of the Dewar. The Dewar is therefore free to rotate about the optical axis to align the CCD rows and columns with the requirements of the instrument, until the retaining ring is tightened, clamping it in place. On the f/9 imaging instrument, the bolt circle in the baseplate for the retaining ring is 7.25 inches in diameter and contains eight 8 – 32 tapped holes spaced at 45° intervals. The nominal f/9 focal plane is located 0.663 inches below the underside of the baseplate; the TV guider can accommodate longer BFLs than this, but not shorter.

3.3 Photon-counting camera configuration

In place of the CCD detector, an alternate photon-counting PAPA⁶ (precision analog photon address) camera, built by X. Pan and S.R. Kulkarni at Caltech, has been used at the 200-inch Cassegrain successfully attached to the new f/9 instrument described above. To accept the larger physical dimensions of the PAPA camera housing, it was necessary to design and build an extension flange which attaches to the f/9 instrument baseplate in place of the CCD retainer rings. Bolt patterns exist at the bottom of the flange which allow either detector (PAPA camera or CCD Dewar) to be located 7.25 inches below the nominal f/9 focal plane used with the CCD. The telescope secondary mirror focus travel is more than sufficient to accommodate this focal plane shift. In order to suppress the peripheral sky background counts detected by the PAPA camera, the extension flange also contains an adjustable iris diaphragm.

The lower focal plane may be served by either the f/9 or f/16 Cassegrain optics. To recover the TV guider focus with the lower focal plane (regardless of the f/ratio used), a second achromatic lens may be installed in the periscope exit beam following the final 45° mirror (D7 in Figures 3 and 5), to re-establish collimated light before the TV camera lens. Meanwhile, the first periscope lens achromat (D6) is now quite close to the shifted focus and so functions mainly as a field lens.

4 PERFORMANCE AND FUTURE WORK

The f/9 CCD camera proved capable of furnishing FWHM image diameters of 0.8-arcseconds during the periods of best seeing in January 1992, and it is certain that the atmospheric seeing and not the f/9 optical system was the limiting factor. A major servicing of the 200-inch mirror back supports⁷ conducted in January 1994 by Palomar Observatory engineering and technical staff is believed to have improved the actual optical performance to the original design goal of 80% encircled energy within 0.45-arcseconds (50% inside 0.33-arcseconds). This is then the optical image quality expected from the f/9 Cassegrain system in the absence of atmospheric seeing.

Future work with the f/9 CCD camera will include improved software for filter selection and offset TV guider positioning. As stated previously, the image scale provided at the f/9 focus is well suited to utilize seeing improvements by adaptive optics, and the f/9 instrument may therefore provide a foundation for future experiments along these lines.

5 ACKNOWLEDGMENTS

It is a pleasure to acknowledge the dedication and skilled fabrication work of Gaston Araya Machining on the 200-inch f/9 Cassegrain CCD Camera, the drafting services of Ms. Kathy Smart, and the contributions of the Palomar engineering staff, particularly Hal Petrie, Bill Douglas, Ernest Croner, John Cromer, and Mike Carr. The preliminary raytrace analysis with Code V was conducted by Caltech graduate student Todd Hunter, whose help is much appreciated. The author wishes to thank Manfred and Mark Grindel at Continental Optical for their multi-layer AR-coating work on the 18-inch diameter lenses; J.K.M. is also grateful for AR-coating funding support provided by Palomar Observatory. Lastly, the help of the Palomar Observatory staff Bob Thicksten, Dave Tennant, Mike Doyle, John Henning, and others in the refurbishment and commissioning of the 200-inch f/9 Cassegrain CCD Camera is most gratefully acknowledged.

6 REFERENCES

- [1] J.E. Gunn and J.A. Westphal, 1981. "Care, feeding, and use of charge-coupled device (CCD) imagers at Palomar Observatory", *Proc. S.P.I.E.*, v. **290**, p. 16.
- [2] A. Dressler, 1994. "COSMIC: The Carnegie Observatories Spectrograph and Imaging Camera", *Palomar Observatory Annual Report 1993*, ed. G. Neugebauer, p. 2.
- [3] J.E. Gunn, M. Carr, G.E. Danielson, E.O. Lorenz, R. Lucinio, V.E. Nenow, J.D. Smith, J.A. Westphal, D.P. Schneider, and B.A. Zimmerman, 1987. *Optical Engineering*, v. **26**, p. 779.
- [4] R.L. Gilliland, T.M. Brown, H. Kjeldsen, J.K. McCarthy, M.L. Peri, J.A. Belmonte, I. Vidal, L. Cram, J. Palmer, S. Frandsen, M. Parthasarathy, L. Petro, H. Schneider, P.B. Stetson, and W.W. Weiss, 1993. "A Search for Solar-like Oscillations in the Stars of M67 with CCD Ensemble Photometry on a Network of 4m Class Telescopes," *A.J.*, v. **106**, pp. 2441-76.
- [5] J.E. Gunn, E.B. Emory, F.H. Harris, and J.B. Oke, 1987. "The Palomar Observatory CCD Camera", *P.A.S.P.*, v. **99**, p. 518.
- [6] C. Papaliolios, P. Nelson, and S. Ebstein, 1985. "Speckle Imaging with the PAPA Detector", *Appl. Opt.*, v. **24**, p. 287.
- [7] D.L. Smith, 1993. "The Bad News Bearings", *Engineering and Science*, v. **LVI**, #4, p. 34.