

The flow induced by the transverse motion of a thin disk in its own plane through a contained rapidly rotating viscous liquid

By D. W. MOORE

Imperial College, London S.W.7

AND P. G. SAFFMAN

California Institute of Technology, Pasadena, California

With an appendix by

T. MAXWORTHY, University of Southern California, Los Angeles, California

(Received 3 April 1969)

A thin circular disk translates slowly in its own plane transverse to the axis of rotation of parallel plane boundaries filled with viscous incompressible liquid. It is shown that the indeterminateness of the geostrophic flow is removed by constraints imposed by the dynamics of free shear layers (Stewartson layers), which surround a Taylor column whose boundary is not a stream surface. Fluid particles cross the Taylor column at the expense of deflexion through a finite angle. A comparison is made with the flow past a fat body (Jacobs 1964), where the geostrophic flow is determined without appeal to the dynamics of the shear layers. The problem is also considered for a disk in an unbounded fluid, and it is shown that to leading order there is no disturbance.

1. Introduction

The space between a pair of rigid planes is filled by incompressible viscous liquid of kinematic viscosity ν . The planes rotate about their common normal—we call this direction vertical for descriptive brevity—with angular velocity Ω and we are interested in the disturbance to the state of rigid rotation of the contained liquid which is created by the slow horizontal translation relative to the fluid of a coplanar rigid disk. By ‘slow’ we imply that the Rossby number $R_0 = U/a\Omega$ is small, where a is the radius of the disk (if circular, otherwise a characteristic horizontal dimension) and U is its speed. Thus we hope to discuss the flow in terms of linearized equations and if, in addition, we assume that the Ekman number $E = \nu/a^2\Omega$ is small, the flow outside certain thin viscous layers will be geostrophic, that is to say, it results from the balance between the Coriolis force and the pressure gradient. However, the determination of this geostrophic flow is not straightforward, and the problem has some novel features.

The Taylor–Proudman theorem insists that the geostrophic velocity field be independent of the vertical co-ordinate, and the inviscid boundary conditions imply only that the geostrophic flow is horizontal. It is clear that any horizontal

flow satisfies the requirement that it does not stretch the vortex lines of the basic rigid rotation. For a body of finite thickness, only the subset of flows that follow contours of fixed height are allowable, which leads to the formation of a Taylor column, i.e. a volume of fluid contained in the vertical circumscribing cylinder and moving with the body.†

But for a body of zero thickness lying in a horizontal plane, there is no reason to anticipate the formation of a Taylor column in the usual sense, and it is impossible to get a picture of the flow without appealing to viscous effects.

The fluid is brought to relative rest at horizontal solid surfaces by the action of viscous forces in thin Ekman boundary layers. The need to be compatible with these places a further constraint on the geostrophic flow. If the vertical velocity and vertical vorticity in the geostrophic flow are w_G and ζ_G , respectively, this constraint takes the form, for the disk problem,

$$w_G = \frac{1}{2} \left(\frac{\nu}{\Omega} \right)^{\frac{1}{2}} \zeta_G$$

on upward facing surfaces (that is, surfaces whose normal into the liquid is parallel to Ω) and

$$w_G = -\frac{1}{2} \left(\frac{\nu}{\Omega} \right)^{\frac{1}{2}} \zeta_G$$

on downward-facing surfaces. If the top surface is free, it cannot sustain an Ekman layer and the compatibility condition is

$$w_G = 0.$$

Now w_G and ζ_G are the same at all points on a vertical line and any such line meets an upward and downward facing surface. Hence

$$w_G = \zeta_G = 0,$$

and it then follows from the geostrophic balance equations that the reduced geostrophic pressure p_G is harmonic.

Now p_G is bounded at large distances from the disk and if it were harmonic everywhere it would be constant and the geostrophic flow would vanish. However, this is not a possible state of affairs for the following reason. There would still be Ekman layers on the disk in which there is a constant volume flux of order $\nu^{\frac{1}{2}}$, in the same direction on each side.‡ Since $w_G = 0$, there is no way to close this flux, except by an azimuthal flux in a collar of cross-section $\nu^{\frac{1}{2}} \times \nu^{\frac{1}{2}}$ around the edge of the disk where the Ekman layers on top and bottom join. To preserve flux continuity, the swirl velocity in the collar must be $O(\nu^{-\frac{1}{2}})$, and the associated velocity gradients are $O(\nu^{-1})$. The rate at which energy is dissipated by viscosity inside the collar is therefore $O(\nu \times \nu^{-2} \times \nu^{\frac{1}{2}} \times \nu^{\frac{1}{2}}) = O(1)$. This is larger than the rate at which energy is dissipated in the Ekman layers,

† This result follows from the purely inviscid non-inertial dynamics only for bodies whose intersection with the circumscribing cylinder is a horizontal curve and whose tangent planes at points on this curve are not horizontal. The case of bodies of finite height which do not satisfy these criteria will be discussed elsewhere.

‡ It is convenient to denote orders of magnitude for small Ekman number by the dependence on ν . This is a consistent procedure for an axially bounded flow, of given geometry.

which is $O(\nu \times \nu^{-1} \times \nu^{\frac{1}{2}}) = O(\nu^{\frac{1}{2}})$, since the velocity gradients in the Ekman layers are $O(\nu^{-\frac{1}{2}})$. Now the drag on the disk due to the viscous stress in the Ekman layer is $O(\nu^{\frac{1}{2}})$, and that due to stresses within the collar is likewise $O(\nu \times \nu^{-\frac{1}{2}} \times \nu^{\frac{1}{2}}) = O(\nu^{\frac{1}{2}})$. Thus the rate at which work is done on the flow is not sufficient to balance the dissipation in the collar (see appendix A).

The only way out is to allow the vertical cylinder circumscribing the disk to be the centre of a set of Stewartson free shear layers which permit axial flow and will allow flux to be completed without the introduction of a collar. Thus a Taylor column of a sort is formed. The geostrophic pressure p_G is no longer analytic in an entire plane and we must seek sufficient jump conditions at its circle of singularity to enable it to be determined. These conditions must come from the dynamics of the Stewartson layers.

The Stewartson layers have the usual sandwich structure with outer layers of thickness proportional to $\nu^{\frac{1}{2}}$ enclosing an inner layer of thickness proportional to $\nu^{\frac{1}{3}}$. The $\frac{1}{3}$ layer is no different from that associated with a rising disk and we have elsewhere (Moore & Saffman 1969, henceforth I) discussed such layers in detail. In the case of the rising disk, the geostrophic flow is determined uniquely without reference to the Stewartson layers, which merely smooth out its discontinuities. In the present case, however, the geostrophic flow (of order unity) is determined by matching to the Stewartson layers.

It turns out from the detailed analysis to be described below that fluid particles can cross the Taylor column and that they suffer a finite deflexion as a result. A flow in which the boundary of the Taylor column is a stream-surface of the geostrophic flow is not a solution of our problem, in contrast to the thick axisymmetrical body case. This is the first example we have encountered where an order unity geostrophic flow is determined by the viscous dynamics of vertical shear layers, and illustrates the seemingly endless variety of flows to be encountered in rapidly rotating systems. It should be noted that the method of removing the non-uniqueness inherent in the geostrophic flow by considering a transient inviscid problem fails completely in this problem, since a thin disk moving in its own plane excites no inertial waves. If to avoid this difficulty we consider instead a thin oblate spheroid, the ultimate steady flow must have the Taylor column boundary as a stream surface. Thus it would appear to be impossible to recover the results of the steady viscous analysis by an unsteady inviscid analysis. This is not the case for a fat body; Stewartson (1967), with an unsteady inviscid analysis, obtains the same final state for the geostrophic flow as Jacobs (1964) obtains with a steady viscous treatment.

We also consider in §6 the flow past a disk in an unbounded fluid. In marked contrast, it is found that the disturbance velocities are $O(E^{\frac{1}{2}})$.

2. The matching to the Stewartson layers

The analysis can be carried out and the harmonic problem for p_G can be formulated for a flat disk of arbitrary shape in a container of arbitrary horizontal cross-section. However, for ease of exposition we shall talk in terms of a circular disk in a horizontally unbounded flow between rigid parallel planes. Since a

'slow' flow can be regarded as quasi-steady, it is convenient to take axes with the disk at rest and the fluid moving horizontally with velocity U . We must suppose the top and bottom planes also move with the same velocity U . We use cylindrical polars (r, θ, z) with origin at the centre of the disk and the $\theta = 0$ direction parallel to U . The bounding planes are $z = h_T$ and $z = -h_B$.

The Taylor column boundary is the circular cylinder $r = a$, and it divides the flow space into three regions. We use a subscript T to denote flow variables in the space above the disk and inside the Taylor column; a subscript B for the space below the disk and inside the Taylor column, and a subscript E for the space outside the column.

The geostrophic velocity components $(u_G, v_G, 0)$ satisfy

$$2\Omega v_G = \frac{\partial p_G}{\partial r}, \quad (2.1)$$

$$-2\Omega u_G = \frac{1}{r} \frac{\partial p_G}{\partial \theta}. \quad (2.2)$$

(It is convenient to choose units with density $\rho = 1$.) Since, as shown in §1, p_G is harmonic, we have, invoking regularity conditions at $r = 0$ and $r = \infty$ and using an obvious notation,

$$p_{GI} = \sum_1^{\infty} \left[C_I^{(n)} \left(\frac{r}{a}\right)^n \cos n\theta + D_I^{(n)} \left(\frac{r}{a}\right)^n \sin n\theta \right], \quad (2.3)$$

where I 'interior' stands for either T or B ,

$$p_{GE} = -2\Omega U r \sin \theta + \sum_1^{\infty} \left[C_E^{(n)} \left(\frac{a}{r}\right)^n \cos n\theta + D_E^{(n)} \left(\frac{a}{r}\right)^n \sin n\theta \right]. \quad (2.4)$$

(The log r term is excluded because the body is not a source of fluid.)

These equations contain all the information about the geostrophic flow which one can obtain without consideration of the shear layers at the Taylor column boundary. We shall show that the dynamics of the shear layers which join the geostrophic flows give sufficient constraints to determine the geostrophic flow uniquely.

As a first step, we remark that p_G must be continuous across the shear layers, i.e.

$$p_{GT} = p_{GB} = p_{GE} \quad \text{on} \quad r = a. \quad (2.5)$$

This is because the balance of Coriolis force and pressure gradient normal to the layer as expressed in (2.1) can be shown to hold also inside the shear layer, so that provided the swirl velocity is of the same order of magnitude in the shear layers as it is in the geostrophic regions, the pressure change across the shear layers is of smaller order. In view of (2.2), the continuity of p_G implies that of u_G , so that the shear layers do not have to redistribute flux between the three geostrophic regions, i.e. flux is conserved in any plane $z = \text{constant}$ outside the Ekman layers. Application of this boundary condition gives

$$\left. \begin{aligned} C_T^{(n)} &= C_B^{(n)} = C_E^{(n)}, \\ D_T^{(n)} &= D_B^{(n)} = D_E^{(n)} - 2\Omega U a \delta_{1n}. \end{aligned} \right\} \quad (2.6)$$

It follows from (2.3), (2.4) and (2.6) that

$$V_{GT}(a-) = V_{GB}(a-) = -V_{GE}(a+) - 2U \sin \theta. \quad (2.7)$$

It is easy to show in a variety of ways (e.g. conformal mapping) that (2.7) holds generally for arbitrary disk shape with $-U \sin \theta$ replaced by the component of the undisturbed geostrophic velocity parallel to the surface of the shear layer, U_{11} , say, and V interpreted as the component parallel to the shear layer. (An observer fixed in the boundaries sees the streamlines refracted so that they make equal and opposite angles with the normal when they cross the Taylor column boundary.)

Next we consider the details of the $\frac{1}{4}$ layers. Their equations of motion are obtained by introducing the viscous force into the azimuthal momentum equation (2.2) and, with boundary layer co-ordinates $y = a\theta$ and $x = r - a$, one has

$$2\Omega v_{\frac{1}{4}} = \frac{\partial p}{\partial x}, \quad (2.8)$$

$$2\Omega u_{\frac{1}{4}} = -\frac{\partial p}{\partial y} + \nu \frac{\partial^2 v_{\frac{1}{4}}}{\partial x^2}, \quad (2.9)$$

$$0 = \frac{\partial p}{\partial z}, \quad (2.10)$$

and
$$\frac{\partial u_{\frac{1}{4}}}{\partial x} + \frac{\partial v_{\frac{1}{4}}}{\partial y} + \frac{\partial w_{\frac{1}{4}}}{\partial z} = 0. \quad (2.11)$$

The suffix $\frac{1}{4}$ denotes a solution of these equations valid in a layer of thickness $\delta_{\frac{1}{4}} = (\nu h / \Omega)^{\frac{1}{2}}$, where $h = h_T + h_B$. Equations (2.8) and (2.10) show that $v_{\frac{1}{4}}$ is independent of z , and from (2.8), (2.9) and (2.11),

$$w_{\frac{1}{4}} = -\frac{\nu z}{2\Omega} \frac{\partial^3 v_{\frac{1}{4}}}{\partial x^3} + W(x, y), \quad (2.12)$$

where W is an arbitrary function of integration.

A second relation between $v_{\frac{1}{4}}$ and $w_{\frac{1}{4}}$ can be obtained from the appropriate form of the Ekman compatibility condition which still holds inside the $\frac{1}{4}$ layers

$$w_{\frac{1}{4}} = \pm \frac{1}{2} \left(\frac{\nu}{\Omega} \right)^{\frac{1}{2}} \frac{\partial v_{\frac{1}{4}}}{\partial x}, \quad (2.13)$$

where the positive sign is taken on upward facing surfaces and the negative sign on downwards facing surfaces. Combining (2.12) and (2.13), we find

$$v_{\frac{1}{4}I} = A_I(y) \exp\{p_I \xi\} + B_I(y), \quad (2.14)$$

$$v_{\frac{1}{4}E} = A_E(y) \exp\{-p_E \xi\} + B_E(y), \quad (2.15)$$

where
$$p_I^2 = 2\Omega^{\frac{1}{2}}/h_I, \quad p_E^2 = 2\Omega^{\frac{1}{2}}/(h_T + h_B), \quad \xi = x/\nu^{\frac{1}{2}}. \quad (2.16)$$

The matching conditions between the $\frac{1}{4}$ layers and the geostrophic flow require that

$$\lim_{\xi \rightarrow \infty} v_{\frac{1}{4}E} = \lim_{r \rightarrow a} v_{GE}, \quad \text{etc.}$$

Hence,
$$B_T = B_B = v_{GI}(a-); \quad B_E = v_{GE}(a+). \quad (2.17)$$

The three unknowns A_T , A_B and A_E can be determined by the requirement that the $\frac{1}{4}$ layers match with a $\frac{1}{3}$ layer which smooths out the discontinuities in the $\frac{1}{4}$ layers across $\xi = 0$. We have elsewhere discussed in much detail, (I), how the dynamics of this $\frac{1}{3}$ layer lead to constraints on the $\frac{1}{4}$ layer it joins. We shall not repeat the argument here but merely state the result that one must have†

$$v_{\frac{1}{4}T} = v_{\frac{1}{4}B} = v_{\frac{1}{4}E}, \quad \text{at } \xi = 0, \quad (2.18)$$

$$h_T \frac{\partial v_{\frac{1}{4}T}}{\partial \xi} + h_B \frac{\partial v_{\frac{1}{4}B}}{\partial \xi} = (h_T + h_B) \frac{\partial v_{\frac{1}{4}E}}{\partial \xi} \quad \text{at } \xi = 0. \quad (2.19)$$

Note that the swirl velocity and total (*not* local) tangential stress are continuous, across the $\frac{1}{3}$ layer. Then we find, using also (2.7) and (2.16), that

$$A_T = A_B = A_E + 2U \sin \theta + 2v_{GE}(a+), \quad (2.20)$$

and
$$h_T p_T A_T + h_B p_B A_B + (h_T + h_B) p_E A_E = 0. \quad (2.21)$$

Thus the shear layer structure is determined in terms of one unknown quantity $v_{GE}(a+)$, that has still to be found.

Continuity of local tangential stress does not provide a further relation; in fact it is obvious that continuity of both swirl velocity and local tangential stress are inconsistent unless $h_T = h_B$, in which case one just reobtains (2.20). The further relation that solves the problem comes from the argument given in §1 that the Stewartson layers must balance the flux at each value of θ or y , so that no collar is required. We shall show how this is to be done in the next section.

3. The flux balance in the $\frac{1}{3}$ layer

Figure 1 is a sketch of the $\frac{1}{3}$ layer and $\frac{1}{4}$ layers near the edge of the disk. Remember that on the scale of the $\frac{1}{4}$ layer, the $\frac{1}{3}$ layer is a sheet of zero thickness on $\xi = 0$. The $\frac{1}{3}$ layer at a given station y receives fluid in three ways. There is an inflow across the vertical sides $E_1 E_2$, $T_1 T_2$, $B_1 B_2$ of amount

$$-h u_{\frac{1}{4}E} + h_T u_{\frac{1}{4}T} + h_B u_{\frac{1}{4}B},$$

evaluated on $\xi = 0$, per unit length of circumference. Next there is the y derivative of the azimuthal flux due to $v_{\frac{1}{3}}$ integrated across the $\frac{1}{3}$ layer. And finally there is an inflow by flux in the Ekman layers on the disk, across $T_2 T_3$ and $B_2 B_3$, which then goes from the Ekman layer into the $\frac{1}{3}$ layer. Since $v_{\frac{1}{4}}$ and $u_{\frac{1}{4}}$ are continuous to leading order across the $\frac{1}{3}$ layer,‡ the Ekman layers on the top and

† These results were deduced in (I) for the case of axisymmetric shear layers. However, it is almost obvious (see §3) that the same governing equation for the $\frac{1}{3}$ layer is obtained when the flow is not axisymmetric and the derivation of (2.18) and (2.19) goes through unaltered.

‡ One can show by an argument like that in §1 that the discontinuity in $u_{\frac{1}{4}}$ across the $\frac{1}{3}$ layer is $o(\nu^{\frac{1}{2}})$.

bottom planes make no net contribution. The net inflow occurs in the Ekman layers on the disk and is, per unit length of circumference,

$$-\frac{1}{2} \left(\frac{\nu}{\Omega} \right)^{\frac{1}{2}} \{ (u_{\frac{1}{4}T} + v_{\frac{1}{4}T}) + (u_{\frac{1}{4}B} + v_{\frac{1}{4}B}) \} = Q(y), \text{ say,} \quad (3.1)$$

where the left-hand side is evaluated in $\xi = 0$. Substituting the $\frac{1}{4}$ layer velocities and retaining only terms of lowest order, we have for the flux across T_2T_3 and B_2B_3 ,

$$Q(y) = -\frac{1}{2} \left(\frac{\nu}{\Omega} \right)^{\frac{1}{2}} \{ 2u_G(a) + v_{GT}(a-) + v_{GB}(a-) + A_T + A_B \}. \quad (3.2)$$

Now this flux $Q(y)$ must go from the Ekman layer into the body of the $\frac{1}{3}$ layer and balance the other two fluxes in order that there should be no flux in the collar. Instead of attempting to calculate the first two fluxes directly, which involves detailed knowledge of the structure of the $\frac{1}{3}$ layer, we will use the dynamics of the $\frac{1}{3}$ layer to obtain an expression for the flux entering the $\frac{1}{3}$ layer at its join to the Ekman layers on the disk.

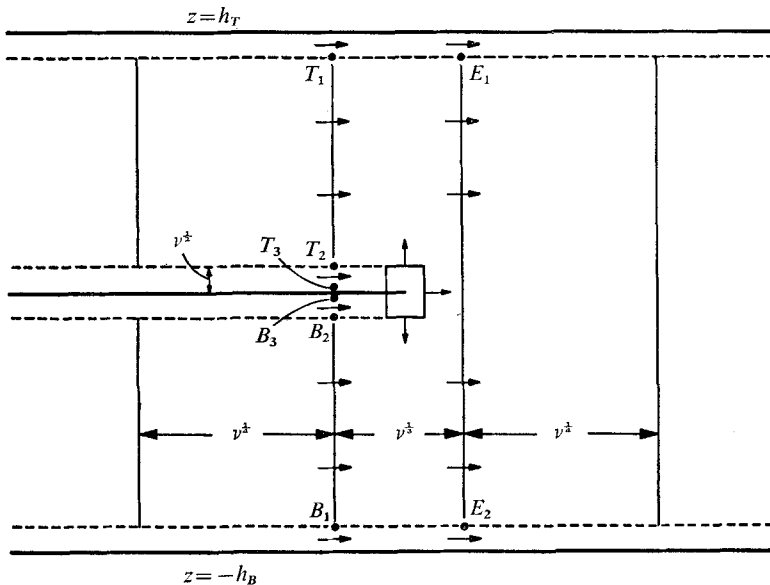

FIGURE 1. Flux balance in the $\frac{1}{3}$ layer.

The equations of motion of the $\frac{1}{3}$ layer are obtained when we modify (2.8)–(2.11) by introducing the viscous force $\nu \partial^2 w_{\frac{1}{3}} / \partial x^2$ into the axial momentum equation (2.10). The resulting equations can be reduced to the pair

$$2\Omega \frac{\partial v_{\frac{1}{3}}}{\partial z} = \nu \frac{\partial^3 w_{\frac{1}{3}}}{\partial x^3}, \quad (3.3)$$

$$-2\Omega \frac{\partial w_{\frac{1}{3}}}{\partial z} = \nu \frac{\partial^3 v_{\frac{1}{3}}}{\partial x^3}, \quad (3.4)$$

from which it is apparent that $v_{\frac{1}{3}} = O(w_{\frac{1}{3}})$ and the shear layer thickness is proportional to $\nu^{\frac{1}{3}}$. With this scaling, the Ekman compatibility condition reduces to

$$w_{\frac{1}{3}} = 0. \tag{3.5}$$

It looks at first sight as if the $\frac{1}{3}$ layer cannot draw any fluid from the Ekman layers, but what (3.5) really implies is that the fluid goes from the Ekman layer into the $\frac{1}{3}$ layer by an eruption from an annular region of width $O(\nu^{\frac{1}{3}})$ and which therefore appears as a source of strength Q on the $\frac{1}{3}$ layer scaling. This singular behaviour is associated with the presence of the disk edge, and there is no transfer of fluid where the $\frac{1}{3}$ layer meets the Ekman layers on $z = h_T$ and $z = -h_B$.

We now follow a procedure due to Stewartson (1966). Equation (3.4) is integrated across the $\frac{1}{3}$ layer at a constant z outside the Ekman layers to give

$$-2\Omega \frac{\partial}{\partial z} \int_{-\infty}^{\infty} w_{\frac{1}{3}} d\eta = \left(\frac{\partial^2 v_{\frac{1}{3}}}{\partial \eta^2} \right)_{\eta=+\infty} - \left(\frac{\partial^2 v_{\frac{1}{3}}}{\partial \eta^2} \right)_{\eta=-\infty}, \tag{3.6}$$

where $\eta = x/\nu^{\frac{1}{3}}$ is the appropriate scaled variable for the $\frac{1}{3}$ layer. Now,

$$\lim_{\eta \rightarrow \pm\infty} v_{\frac{1}{3}}(\eta, z, \theta) = \lim_{\xi \rightarrow 0\pm} v_{\frac{1}{4}}(\xi, z, \theta), \text{ etc.} \tag{3.7}$$

by the requirement that the $\frac{1}{3}$ and $\frac{1}{4}$ layers match, and $v_{\frac{1}{4}}$ is independent of z . Hence integrating (3.6) from $z = 0+$ (just outside the upper Ekman layer on the disk) to $z = h_T -$ (just below the Ekman layer on the upper bounding plane), we find

$$-2\Omega \int_{-\infty}^{\infty} \{w_{\frac{1}{3}}(\eta, h_T -) - w_{\frac{1}{3}}(\eta, 0+)\} d\eta = h_T \nu^{\frac{1}{3}} \left[\left(\frac{\partial^2 v_{\frac{1}{4}E}}{\partial \xi^2} \right)_{\xi=0+} - \left(\frac{\partial^2 v_{\frac{1}{4}T}}{\partial \xi^2} \right)_{\xi=0-} \right],$$

and similarly

$$-2\Omega \int_{-\infty}^{\infty} \{w_{\frac{1}{3}}(\eta, 0-) - w_{\frac{1}{3}}(\eta, -h_B+)\} d\eta = h_B \nu^{\frac{1}{3}} \left[\left(\frac{\partial^2 v_{\frac{1}{4}E}}{\partial \xi^2} \right)_{\xi=0+} - \left(\frac{\partial^2 v_{\frac{1}{4}B}}{\partial \xi^2} \right)_{\xi=0-} \right].$$

Adding these two equations we have, on substituting the expressions for $v_{\frac{1}{4}}$,

$$\int_{-\infty}^{\infty} \{w_{\frac{1}{3}}(\eta, 0+) - w_{\frac{1}{3}}(\eta, 0-)\} dx = \frac{\nu^{\frac{1}{3}}}{2\Omega} [h p_E^2 A_E - h_T p_T^2 A_T - h_B p_B^2 A_B]. \tag{3.8}$$

By conservation of flux inside the Ekman layer and the argument that the flux in the collar is $o(\nu^{\frac{1}{3}})$, the left-hand side of (3.8) which gives the flux from the Ekman layer into the $\frac{1}{3}$ layer must equal the inflow $Q(y)$. (The azimuthal flux in the Ekman layer under the $\frac{1}{3}$ layer is $O(\nu^{\frac{1}{3}} \times \nu^{\frac{1}{3}})$ and is of higher order.)

Then equating (3.8) and (3.2), substituting for A_T, A_B and A_E from (2.20), and using (2.7), we obtain after some reduction

$$u_G(a) + v_{GE}(a+) - (h_T p_T^2 + h_B p_B^2)(v_{GE}(a+) + U \sin \theta) \Omega^{-\frac{1}{2}} = -\frac{1}{2} A_E \{2 + (h p_E^2 - h_T p_T^2 - h_B p_B^2) \Omega^{-\frac{1}{2}}\}. \tag{3.9}$$

Substitution of the values (2.16) for p_E, p_T, p_B makes the right-hand side of (3.9) vanish and we are left with

$$u_G - 3v_{GE} - 4U \sin \theta = 0 \tag{3.10}$$

on the Taylor column boundary $r = a$. Equation (3.10) can be expressed as a boundary condition on the exterior geostrophic pressure and we now have

sufficient boundary conditions to determine uniquely the geostrophic flow. The derivation of this result nowhere depended crucially on the disk being a circle, and it is obvious that the result holds for an arbitrary disk in a co-ordinate system in which the disk is at rest with quantities evaluated on the Taylor column boundary, u and v the components normal and parallel to the shear layer and $-U \sin \theta$ replaced by U_{11} , the component of the undisturbed geostrophic flow parallel to the shear layer.

It is appropriate to mention here the result for the case when the upper surface is free and cannot sustain an Ekman layer.† Everything remains the same except the Ekman compatibility condition on $z = h_T$ which becomes $w_{\frac{1}{2}} = 0$ from which it follows that now

$$p_T^2 = \Omega^{\frac{1}{2}}/h_T, \quad p_B^2 = 2\Omega^{\frac{1}{2}}/h_B, \quad p_E^2 = \Omega^{\frac{1}{2}}/(h_T + h_B). \quad (3.11)$$

Substitution in (3.9) now gives

$$u_G - 2v_{GE} = 3U \sin \theta = 0. \quad (3.12)$$

4. The geostrophic motion

We insert the velocities which follow from the geostrophic pressure distribution (2.4) into the boundary condition (3.10). We find almost immediately that

$$p_{GE} = -2\Omega U r \sin \theta + \frac{4}{3}\Omega U (a^2/r) \sin \theta - \frac{2}{3}\Omega U (a^2/r) \cos \theta, \quad (4.1)$$

$$p_{GI} = -\frac{6}{5}\Omega U r \sin \theta - \frac{2}{5}\Omega U r \cos \theta. \quad (4.2)$$

The streamlines (for motion relative to the disk) are given by $p_G = \text{const.}$, and are sketched in figure 2. The streamlines for motion relative to the boundaries can be found by superposing a velocity $-U$ on the whole system. Note that the streamlines inside the Taylor column are straight, the velocity is $\sqrt{(\frac{2}{3})}U$ and it is inclined at an angle $\tan^{-1}\frac{1}{3} = 18.4^\circ$ with the flow at infinity, the deflexion being opposite to the direction of rotation.

The case when the upper surface is free follows on using (3.12). One finds that

$$p_{GI} = -\frac{4}{3}\Omega U r \sin \theta - \frac{2}{3}\Omega U r \cos \theta. \quad (4.3)$$

The velocity in the Taylor column is $\sqrt{(\frac{1}{3})}U$ and the deflexion is $\tan^{-1}\frac{1}{2} = 26.5^\circ$.

One can also investigate the motion generated when the disk slides along the lower bounding plane. The results cannot be deduced merely by letting $h_B \rightarrow 0$ in the previous analysis, since it was assumed implicitly that all four Ekman layers are distinct. However, it is easy to see that the analysis of §2 goes through with the bottom interior layer deleted, and likewise expression (3.8) for the flux into the $\frac{1}{3}$ layer. The difference is solely in expression (3.2) for the inflow due to the flux in the Ekman layer. By reference to figure 3, it is clear that now

$$\begin{aligned} Q(y) &= -\frac{1}{2} \left(\frac{\nu}{\Omega} \right)^{\frac{1}{2}} \{ (u_{\frac{1}{2}I} + v_{\frac{1}{2}I}) - (u_{\frac{1}{2}E} - u_w) - (v_{\frac{1}{2}E} - v_w) \}, \\ &= -\frac{1}{2} \left(\frac{\nu}{\Omega} \right)^{\frac{1}{2}} (u_w + v_w), \end{aligned} \quad (4.4)$$

† For the analysis to apply, the deformation of the surface must be $o(aE^{\frac{1}{2}})$, which is satisfied if $a\Omega^2/g = o(E^{\frac{1}{2}})$.

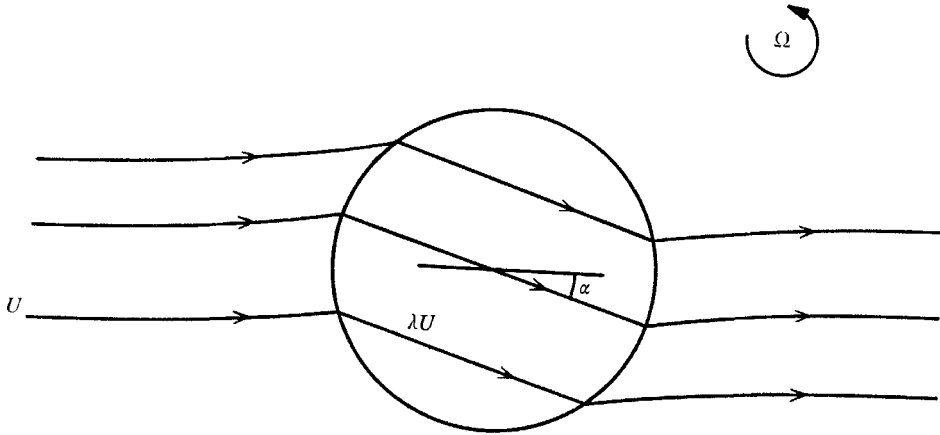

FIGURE 2. Sketch of streamlines for motion relative to circular disk.

Disk between rigid boundaries	$\alpha = \tan^{-1}\frac{1}{3}, \lambda = (\frac{2}{3})^{\frac{1}{2}}$
Upper boundary free	$\alpha = \tan^{-1}\frac{1}{2}, \lambda = (\frac{1}{6})^{\frac{1}{2}}$
Disk on lower rigid boundary, upper surface rigid	$\alpha = \tan^{-1}\frac{1}{3}, \lambda = (\frac{5}{8})^{\frac{1}{2}}$
Disk on lower rigid boundary, upper surface free	$\alpha = \tan^{-1}1, \lambda = (\frac{1}{2})^{\frac{1}{2}}$

(A streamline pattern of this kind was predicted by Stewartson (1953) for motion of an ellipsoid in an unbounded fluid, by means of an unsteady inviscid analysis. But the deflexion goes to zero as the ellipsoid degenerates into a disk, and we believe the similarity is coincidental.)

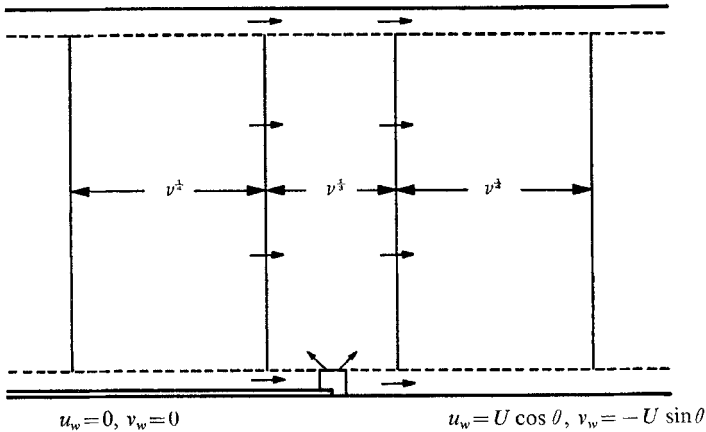

FIGURE 3. Flux balance in the $\frac{1}{2}$ layer when disk is at rest on moving bottom wall.

evaluated on $\xi = 0$, where u_w and v_w are the velocity components of the bottom bounding plane, and we have used the fact that $u_{\frac{1}{2}}$ and $v_{\frac{1}{2}}$ are continuous across $\xi = 0$ to leading order. (Remember also that we are using a co-ordinate system in which the disk is at rest.) If we now equate (4.4) with (3.8), and repeat the subsequent steps of §3, we find to replace (3.9),

$$\frac{2h}{\Omega^{\frac{1}{2}}} p_I^2 (v_{GE}(a+) + U \sin \theta) - (u_w + v_w) = \frac{h}{\Omega^{\frac{1}{2}}} (p_E^2 - p_I^2) A_E. \quad (4.5)$$

For the motion produced by a disk sliding along the bottom, (4.5) reduces to the boundary condition on $r = a$,

$$4v_{GE} + 5U \sin \theta - U \cos \theta = 0, \quad (4.6)$$

when the upper surface is rigid; and

$$2v_{GE} + 3U \sin \theta - U \cos \theta = 0, \quad (4.7)$$

when the upper surface is free. The corresponding geostrophic pressures in the interior are

$$p_{GI} = -\frac{3}{2}\Omega Ur \sin \theta - \frac{1}{2}\Omega Ur \cos \theta \quad (4.8)$$

for upper surface rigid; and

$$p_{GI} = -\Omega Ur \sin \theta - \Omega Ur \cos \theta \quad (4.9)$$

for upper surface free.

The force on the disk follows immediately from the standard result for Ekman layers that the wall stress in $(2\Omega\nu)^{\frac{1}{2}}$ times the geostrophic velocity above the layer in the direction at 45° in the sense of the rotation.

In a container that is bounded horizontally by vertical walls, the exterior geostrophic flow adjusts to the vertical walls through Stewartson layers. The boundary condition on the geostrophic flow is that the normal velocity should equal the normal velocity of the wall, with the Stewartson layers absorbing the discontinuity in tangential velocity. A discontinuity of normal velocity would require velocities $O(\nu^{-\frac{1}{2}})$ and an energy dissipation $O(1)$, which is not matched by any input of work.

We conclude this section by considering the conditions which must hold if the analysis is to be valid. These are of two kinds. (i) The $\frac{1}{4}$ layers must be thin and this requires $h/a \ll E^{-\frac{1}{2}}$ so that the apparatus must not be of too great an axial extent. Also the thickness of the plate must be small compared with the thickness of the Ekman layers. (ii) The linearization of the full equations of motion must be valid everywhere in the flow region. Its validity in the geostrophic region and in the Ekman layers is guaranteed by the assumption $R_0 \ll 1$, but its validity in the interior of the shear layers places a more stringent requirement on the flow parameters. The linearization can be shown to be valid if

$$\left| \frac{\partial v}{\partial r} \right| \ll \Omega.$$

Now in the $\frac{1}{4}$ layers $v = O(U)$, while in the $\frac{1}{2}$ layers the fluctuating part of the

swirl velocity is not more than $O(U\nu^{1/2})$,† so that the condition will be satisfied everywhere if

$$R_0 E^{-1/2} \ll 1.$$

This is a much less stringent requirement than arises in the problem of axial motion of a body (I) and should not be hard to satisfy in a laboratory situation.

5. Shear-layer structure for a fat body

The structure of the shear layers around an axisymmetric fat body was studied by Jacobs (1964). Because the body is fat, the indeterminacy of the geostrophic flow in the Taylor column disappears and the only solution of the geostrophic equations consistent with Ekman layers is that in which the fluid inside the Taylor column is stagnant. The purpose of the shear layers in this case is to remove discontinuities in the geostrophic flow, in marked contrast to the thin disk case where the geostrophic flow is itself determined by the need to fit shear layers. In view of this difference, it seems worthwhile to point out the differences in the shear layer structure for the two cases. For simplicity, we consider a lenticular axisymmetric body, with equation $z = \pm f(r)$, $r \leq a$, and $f'(a)$ finite and non-zero, midway between rigid horizontal planes $z = \pm \frac{1}{2}h$.

With uniform flow of velocity U at large distances from the body, the geostrophic flow is, to leading order,

$$p_{GE} = -2\Omega U r \sin \theta + 2\Omega U (a^2/r) \sin \theta, \quad p_{GI} = 0. \quad (5.1)$$

The $\frac{1}{4}$ layer equations (2.8)–(2.11) are unchanged, but the Ekman compatibility condition (2.13) is changed for the interior region, and the condition on the body is replaced by

$$w_{\frac{1}{4}} + u_{\frac{1}{4}} \tan \beta = \pm \frac{1}{2} \left(\frac{\nu}{\Omega \cos \beta} \right)^{\frac{1}{2}} \frac{\partial v_{\frac{1}{4}}}{\partial x} \quad \text{on } z = \pm 0, \quad x < 0, \quad (5.2)$$

where $\beta = \tan^{-1}\{f'(a)\}$ is the slope of the body at the rim. The solution (2.14) is now not correct for the interior region but we find, on combining (2.12) with the Ekman conditions and eliminating $u_{\frac{1}{4}}$, that $v_{\frac{1}{4}}$ satisfies

$$\frac{h}{4\Omega} \frac{\partial^4 v_{\frac{1}{4}}}{\partial \xi^4} - \frac{1 + (\cos \beta)^{-1/2}}{2\Omega^{1/2}} \frac{\partial^2 v_{\frac{1}{4}}}{\partial \xi^2} = \tan \beta \frac{\partial v_{\frac{1}{4}}}{\partial y}. \quad (5.3)$$

If $\beta = 0$, we re-obtain the equation whose solution is (2.14), but for $\beta > 0$, the equation is of higher order and the solution has additional arbitrary constants. Thus after matching the solution to the geostrophic flow in the interior which in this case is zero, there are still two unknown parameters in the $\frac{1}{4}$ layer solution for $\xi < 0$. The unknown geostrophic flow for the thin disk case is replaced by an additional constant of integration for the fat body case. The continuity of swirl velocity, tangential stress and flux balance in the $\frac{1}{3}$ layer are then sufficient to

† This is because there may be a discontinuity of $\partial v_{\frac{1}{4}}/\partial \xi$ to be smoothed out. Thus $v_{\frac{1}{4}}/\nu^{\frac{1}{2}} \sim v_{\frac{1}{4}}/\nu^{\frac{1}{2}}$, giving the estimate quoted.

determine the solution and one obtains the shear layer structure essentially given by Jacobs (1964).

When the body is of thickness $o(a)$ and has a slope $o(1)$, (5.3) shows that the shear layer has a double structure. There is a $\frac{1}{4}$ layer of the same structure as that found for the disk, and separating it from the stagnant interior is a fatter geostrophic penetration layer of thickness $aE^{\frac{1}{4}}/|\beta|^{\frac{1}{2}}$. Thus when $|\beta| = O(E^{\frac{1}{2}})$, so that the thickness of the body is comparable to the Ekman layer thickness, we get a transition from the stagnant Taylor column predicted by Jacobs to the deflected flow we predict for the disk.

6. Motion of a disk in an unbounded fluid

The question naturally arises of what is the flow when the horizontal walls are absent and the fluid is unbounded. We shall show now that the flow produced in this case by the transverse motion of a thin disk is of smaller order of magnitude, being $O(\nu^{\frac{1}{2}})$. A Taylor column is produced by the disk, but the change in the geostrophic flow is small, and is not $O(1)$ as when horizontal walls produce extra constraints.

We take axes fixed in the disk and use cylindrical polar co-ordinates. The analysis will be for a circular disk of radius a in a stream of velocity U parallel to $\theta = 0$. Further, we shall suppose that the non-linear terms are completely negligible, and that $\nu/\Omega a^2 \ll 1$. Then outside Ekman layers on the disk, the vertical derivatives of the velocity are small compared with the horizontal derivatives, and the approximate equations of motion are

$$-2\Omega v = -\frac{\partial p}{\partial r} + \nu \left(\nabla_1^2 u - \frac{u}{r^2} - \frac{2}{r^2} \frac{\partial v}{\partial \theta} \right), \quad (6.1)$$

$$2\Omega u = -\frac{1}{r} \frac{\partial p}{\partial \theta} + \nu \left(\nabla_1^2 v - \frac{v}{r^2} + \frac{2}{r^2} \frac{\partial u}{\partial \theta} \right), \quad (6.2)$$

$$0 = -\frac{\partial p}{\partial z} + \nu \nabla_1^2 w, \quad (6.3)$$

$$\frac{\partial u}{\partial r} + \frac{u}{r} + \frac{1}{r} \frac{\partial v}{\partial \theta} + \frac{\partial w}{\partial z} = 0, \quad (6.4)$$

where

$$\nabla_1^2 \equiv \frac{\partial^2}{\partial r^2} + \frac{1}{r} \frac{\partial}{\partial r} + \frac{1}{r^2} \frac{\partial^2}{\partial \theta^2}.$$

For reasons explained in I, where the problem of vertical motion in an unbounded fluid was examined, the shear layers on $r = a$ cannot be treated by the boundary-layer approximation.

The boundary conditions at infinity are

$$u \rightarrow U \cos \theta, \quad v \rightarrow -U \sin \theta, \quad w \rightarrow 0. \quad (6.5)$$

It may be verified by substitution that a general solution of these equations is

$$u = \text{Re} \left[U e^{i\theta} + U e^{i\theta} \int_0^\infty A(k) e^{-\nu\alpha|z|} \left(\frac{J_0(kr)}{k^2\nu - 2\Omega i} - \frac{J_2(kr)}{k^2\nu + 2\Omega i} \right) dk \right], \quad (6.6)$$

$$v = \text{Re} \left[U i e^{i\theta} + U i e^{i\theta} \int_0^\infty A(k) e^{-\nu\alpha|z|} \left(\frac{J_0(kr)}{k^2\nu - 2\Omega i} + \frac{J_2(kr)}{k^2\nu + 2\Omega i} \right) dk \right], \quad (6.7)$$

$$w = \text{Re} \left[-2U e^{i\theta} \int_0^\infty \frac{A(k)}{(k^4\nu^2 + 4\Omega^2)^{\frac{1}{2}}} e^{-\nu\alpha|z|} J_1(kr) dk \right], \quad (6.8)$$

$$p = \text{Re} \left[2\Omega U i r e^{i\theta} - 2U e^{i\theta} \int_0^\infty \frac{A(k)}{k} e^{-\nu\alpha|z|} J_1(kr) dk \right], \quad (6.9)$$

where
$$\alpha = k^3 / (k^4\nu^2 + 4\Omega^2)^{\frac{1}{2}}. \quad (6.10)$$

The boundary conditions on the plane $z = 0$ are from symmetry

$$w = 0 \quad \text{for } r > a; \quad (6.11)$$

and
$$w = \frac{1}{2} \left(\frac{\nu}{\Omega} \right)^{\frac{1}{2}} \left(\frac{\partial v}{\partial r} + \frac{v}{r} - \frac{1}{r} \frac{\partial u}{\partial \theta} \right) \quad \text{for } r < a, \quad z = 0+, \quad (6.12)$$

from the Ekman compatibility condition on the disk. Because the Ekman layers come to a sudden stop at $r = a$, there has to be a singularity there so that flux is conserved without producing a collar flux. The radial Ekman layer flux at $r = a$ is

$$-\frac{1}{2} \left(\frac{\nu}{\Omega} \right)^{\frac{1}{2}} (u + v)$$

and hence from flux conservation,

$$w = -\frac{1}{2} \left(\frac{\nu}{\Omega} \right)^{\frac{1}{2}} (u + v) \delta(r - a) \quad \text{for } z = 0+, \quad (6.13)$$

in addition to (6.11) and (6.12).

It is clear from (6.6)–(6.8) that u , v and w are in the unbounded case of the same order of magnitude. Hence, the boundary conditions (6.11) and (6.12) imply that $A(k) = O(\nu^{\frac{1}{2}})$, and hence to leading order, $u = U \cos \theta$, $v = -U \sin \theta$. The disturbance produced by the disk is found by substituting these values into the right-hand sides of (6.12) and (6.13) and we obtain the equation

$$\int_0^\infty \frac{A(k)}{(k^4\nu^2 + 4\Omega^2)^{\frac{1}{2}}} J_1(kr) dk = \frac{1}{4} \left(\frac{\nu}{\Omega} \right)^{\frac{1}{2}} (1 + i) \delta(r - a), \quad (6.14)$$

whose solution is

$$\begin{aligned} A(k) &= \frac{1}{4} \left(\frac{\nu}{\Omega} \right)^{\frac{1}{2}} (k^4\nu^2 + 4\Omega^2)^{\frac{1}{2}} (1 + i) a k J_1(ka) \\ &\doteq \frac{1}{2} (\nu\Omega)^{\frac{1}{2}} a k (1 + i) J_1(ka), \end{aligned} \quad (6.15)$$

since we may neglect $k^4\nu^2$ in comparison with Ω^2 when $\nu/\Omega a^2 \ll 1$.

The substitution of (6.15) into (6.6)–(6.9) gives the velocity and pressure fields as complicated integrals. On $z = 0$, we find for the pressure

$$p_G = -2\Omega U r \sin \theta - U(\nu\Omega)^{\frac{1}{2}} (\cos \theta - \sin \theta) \int_0^\infty a J_1(ka) J_1(kr) dk. \quad (6.16)$$

The integral in (6.16) is equal to

$$\left. \begin{aligned} & \left(\frac{2a}{\pi r} \right) \left[K \left(\frac{r}{a} \right) - E \left(\frac{r}{a} \right) \right] \quad \text{for } r < a, \\ & \left(\frac{2}{\pi} \right) \left[K \left(\frac{a}{r} \right) - E \left(\frac{a}{r} \right) \right] \quad \text{for } r > a, \end{aligned} \right\} \quad (6.17)$$

where K and E are the complete elliptic integrals of the first and second kind (Jahnke & Emde 1945). As $\kappa \rightarrow 1$, $E(\kappa) \rightarrow 1$ and $K(\kappa) \rightarrow \frac{1}{2} \log [16/(1-\kappa^2)]$. Thus the pressure has a logarithmic singularity on the disk edge, and the tangential velocity is singular like $(r-a)^{-1}$.

For $z > 0$, the singularities are smoothed out in a shear layer of thickness

$$\delta \sim \left(\frac{\nu z}{\Omega} \right)^{\frac{1}{3}}. \quad (6.18)$$

The disturbances decrease slowly as z increases and will be negligible when $\delta \sim a$, i.e. $z \sim \Omega a^3/\nu$. Thus a Taylor column of a sort is formed. Note also that the flow disturbance is not irrotational. The theory will apply in a container of height H if $H \gg a/E$. (Remember that the theory for contained flow required $H \ll a/E^{\frac{1}{2}}$).

The above solution applies without change if the motion is produced by the disk sliding over a rigid plane at the bottom of a semi-infinite volume of fluid.

The expressions (6.6)–(6.9) can be made the basis of a treatment of the Taylor column produced by flow past a fat body in an unbounded fluid; this would be the steady viscous analogue of the unsteady inviscid problem solved by Stewartson (1953). But we shall defer discussion to a later paper.

Finally, it should be mentioned that the neglect of convective accelerations in the unbounded case puts a more stringent requirement on the Rossby number than in the bounded case. For instance, the neglect of $U \partial w / \partial x$ requires that $U \ll \nu/\delta$. Near the body, this requires $R_0 \ll E^{\frac{3}{2}}$. If this condition is satisfied, inertial effects will become important when $z \sim aE^2/R_0^3$, and will presumably show up first as a deflexion of the Taylor column.

Appendix A. Energy dissipation

The full linearized equation of motion is

$$2\Omega \wedge \mathbf{u} = -\nabla p + \nu \nabla^2 \mathbf{u}. \quad (\text{A } 1)$$

Taking the scalar product with \mathbf{u} and applying the divergence theorem, we obtain

$$-\int p u_i n_i dS + \nu \int u_i \left(\frac{\partial u_i}{\partial x_j} + \frac{\partial u_j}{\partial x_i} \right) n_j dS = \frac{\nu}{2} \int \left(\frac{\partial u_i}{\partial x_i} + \frac{\partial u_j}{\partial x_j} \right)^2 dV, \quad (\text{A } 2)$$

where \mathbf{n} is the normal out of the fluid. The left-hand side of (A 2) is the rate at which work is done on the fluid by the stresses over the bounding surfaces moving with the velocities measured relative to the rotating co-ordinates, and the right-hand side is the rate at which energy is dissipated into heat. Equation (A 2) justifies the use of energy dissipation arguments to the relative motion, even

though the system is not closed because it is constrained to rotate with constant angular velocity Ω .

For flow past a body at rest, the contribution to the left-hand side of (A2) from the integrals over the body vanishes. The geostrophic contribution to the first term also vanishes since $\mathbf{u}_G \cdot \mathbf{n} = -(\frac{1}{2}\Omega)\partial p_G/\partial s$, and p_G is single valued.

Appendix. Some experimental observations†

By T. MAXWORTHY, University of Southern California, Los Angeles, California, U.S.A.

The results reported in the main body of this paper were considered to be so unexpected that some experimental demonstration of the main effects seemed very desirable. No effort, as yet, has been made to cover an extensive range of the relevant parameters so only the simplest observations will be presented.

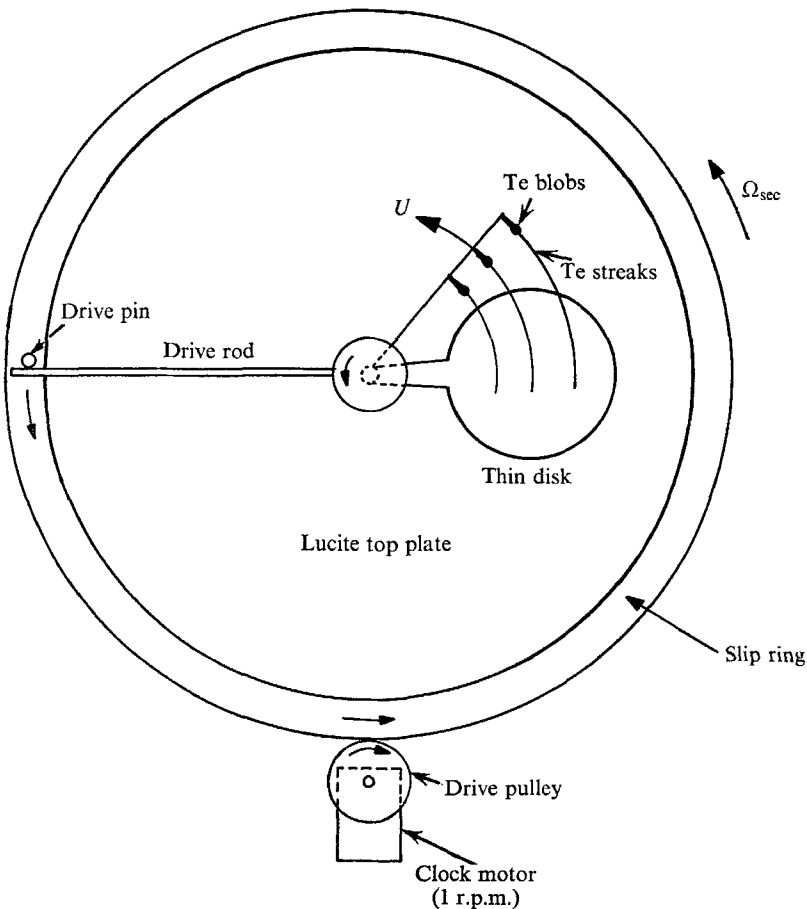

FIGURE 4. Top view of rotating tank apparatus showing mechanism to drive a thin disk at low velocity and observe the flow streamlines.

† This work was supported at the University of Southern California by the National Science Foundation under Grant GK-2731.

For mechanical simplicity a thin (0.005 in. thick) 2 in. diameter disk was rotated about the axis of a rapidly rotating cylinder of fluid figure 4. The motion of the disk was slow relative to a co-ordinate system fixed within the rotating tank. Controlling parameters are an Ekman number ($E = \nu/\Omega a^2$), a Rossby number ($Ro = U/\Omega a$) and two depth parameters h/a and H/a . Here Ω is the rotation rate of the tank; a is the radius of the disk and U is its mean velocity, i.e. the velocity of the centre of the disk with respect to the tank; h is the depth of the disk below the top plate and H the total depth of the fluid.

Flow observations were made using the 'tellurium' precipitation method. Small blobs of a tellurium-glue mixture were attached to the tips of a thin metal rake which rotated with the disk. The disk was a distance $3a$ below the top plate ($h/a = 3$; $H/a = 14$) and the rake was $1.5a$ below. Electrical contact was made through a system of slip rings machined into the turntable of the device. When a small voltage was applied, between the Te blobs and an electrode suspended elsewhere within the fluid, colloidal Te was released. Since disk and rake rotated together the lines thus formed were steady streamlines with respect to the disk.

Figure 5, plate 1, shows the results of such observations. Figure 5(a) is for the case when $\Omega = 0$ and the streamlines are circles; disturbed streamlines are shown superimposed so that the bending of the flow can be clearly seen. Figure 5(b) shows the streamlines for $Ro = 1.20 \times 10^{-2}$ and $E = 4.65 \times 10^{-4}$. Typically the flow is rotated through an angle of 20° !

REFERENCES

- JACOBS, S. 1964 The Taylor column problem. *J. Fluid Mech.* **20**, 581.
JAHNKE, E. & EMDE, F. 1945 *Tables of Functions*. New York: Dover.
MOORE, D. W. & SAFFMAN, P. G. 1969 The structure of free vertical shear layers in a rotating fluid and the motion produced by a slowly rising body. *Phil. Trans. Roy. Soc. Lond. A* **264**, 597.
STEWARTSON, K. 1953 On the slow motion of an ellipsoid in a rotating fluid. *Quart. J. Mech. appl. Math.* **6**, 141.
STEWARTSON, K. 1966 On almost rigid rotations. Part 2. *J. Fluid Mech.* **26**, 131.
STEWARTSON, K. 1967 On slow transverse motion of a sphere through a rotating fluid. *J. Fluid Mech.* **30**, 357.

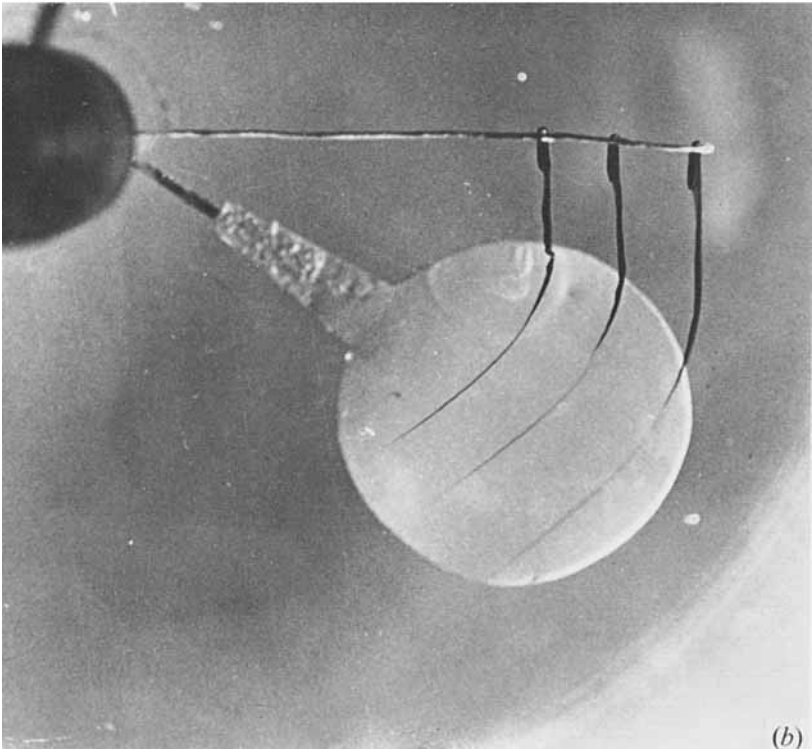
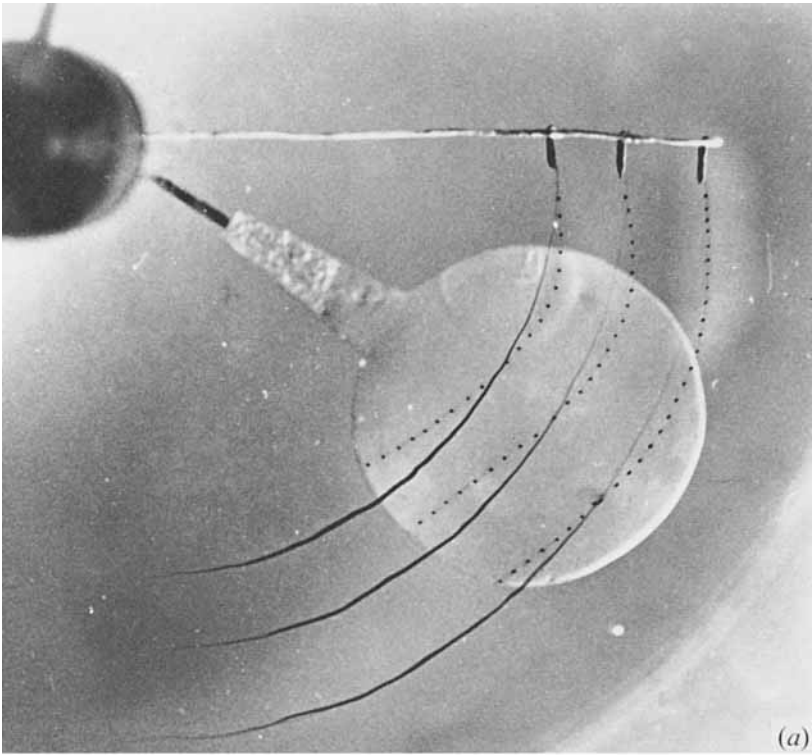

FIGURE 5. (a) Photograph of undisturbed streamlines with disturbed streamlines superimposed. (b) Disturbed streamlines for $Ro = 1.20 \times 10^{-2}$, $E = 4.65 \times 10^{-4}$.