

Supporting Information

Anion-catalyzed dissolution of NO₂ on aqueous microdroplets

A. Yabushita[†], S. Enami[‡], Y. Sakamoto[†], M. Kawasaki[†], M. R. Hoffmann[‡] and A. J. Colussi^{‡*}

[†]*Department of Molecular Engineering, Kyoto University, Kyoto 615-8510, Japan*

[‡]*W. M. Keck Laboratories, California Institute of Technology, Pasadena, CA 91125, U.S.A.*

Methods

All experiments were conducted in a commercial electrospray ionization mass spectrometer (HP-1100 MSD)¹⁻⁴ modified with the NO₂(g) injection system shown in Fig. S1. The setup was essentially identical to that used in previous studies of O₃(g) reactions from our laboratory.⁵⁻⁹ Aqueous solutions were pumped (20 μL min⁻¹, Harvard Apparatus) into the spraying chamber through a grounded stainless steel needle injector (100 μm bore) and pneumatically nebulized by means of N₂ gas flowing through a coaxial sheath. The difference between the exit velocities of the liquid jet (10.6 cm s⁻¹) and nebulizer gas (2.65 x 10⁴ cm s⁻¹) is so large that the drag imposed on the liquid breaks it apart into sub-micrometer size droplets. The terminal velocities of the microdroplets thus produced exceed ~10³ cm s⁻¹,¹⁰ which lead to transit times shorter than $\tau \sim 1$ ms across the ~ 0.5 cm wide NO₂(g) plume. NO₂/N₂ gas mixtures were introduced into the spraying chamber in a direction perpendicular to a stainless steel needle injector and mass spectrometer, respectively (see Fig. S1). This geometry was chosen to prevent unwanted NO₂ losses on the wall of the spraying chamber. NO₂ concentrations were determined by UV absorption spectrophotometry (HP 8452) at 400 nm¹¹. The NO₂ concentration in the chamber was calculated from the combined NO₂/N₂ mixture and N₂ drying gas flow rates. The [NO₂(g)] values reported in the figures throughout

correspond to the concentrations actually sensed by microdroplets in the spraying chamber, which are ~13 times smaller than the values determined from UV absorbance due to further dilution by the N₂ drying gas. Gas flows were regulated by calibrated mass flow controllers (MKS). Typical instrumental parameters were as follows: drying gas temperature, 350 °C; drying gas flow rate, 13 L min⁻¹; Nebulizer pressure, 2 atm; collector capillary voltage, 3.5 kV; fragmentor voltage, 22 V, unless otherwise noted in the text. Solutions were prepared in MilliQ water. NaHSO₄ (>99%), NaF (>99%), NaCl (>99%), NaBr (>99%), NaI (>99%) were used as received. Solutions pH was adjusted by HCl and NaOH and measured with a calibrated pH meter (VWR).

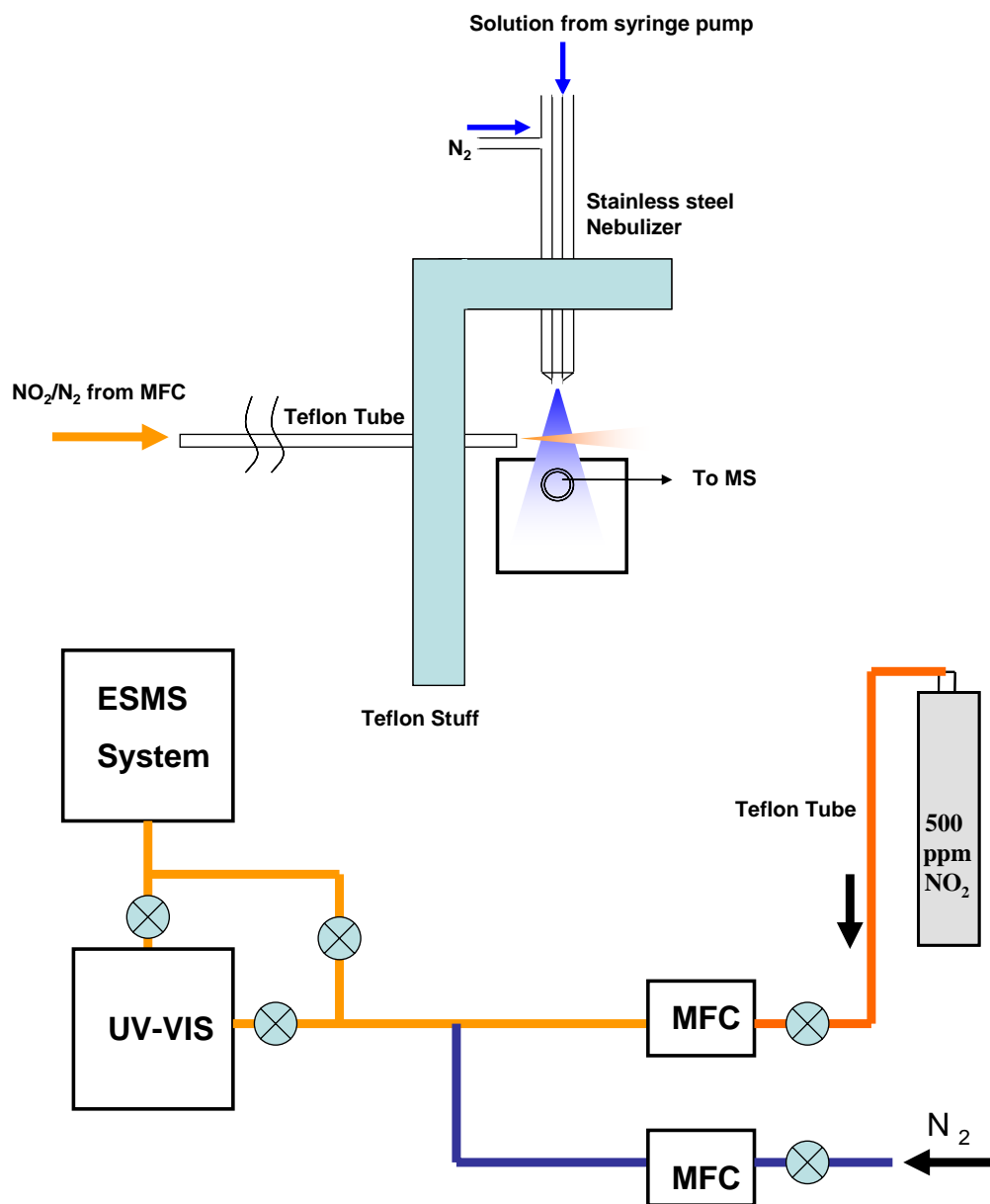

Figure S1. Schematic diagram of the spraying chamber with the NO₂(g) injection system (top) and overview of the experimental setup (bottom). MFC stands for mass flow controller.

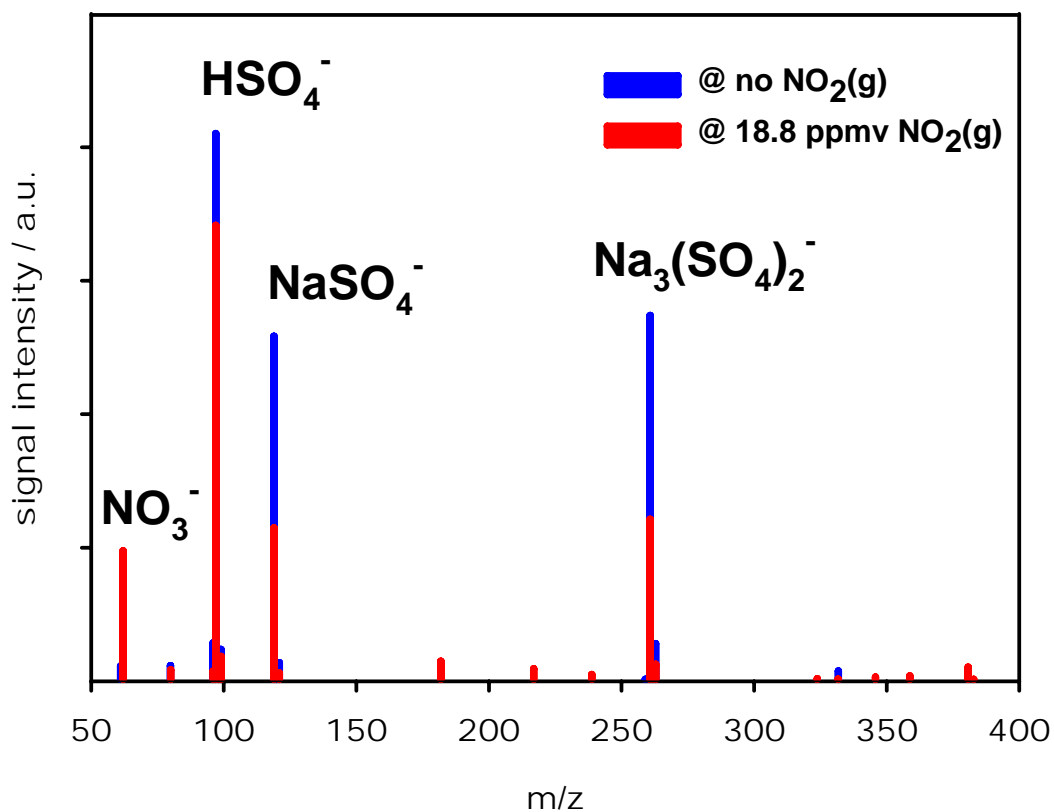

Figure S2. Thermospray mass spectrum of 1mM NaHSO₄ at pH 3.0 in the absence (blue trace)/presence (red trace) of 18.8 ppmv NO₂(g).

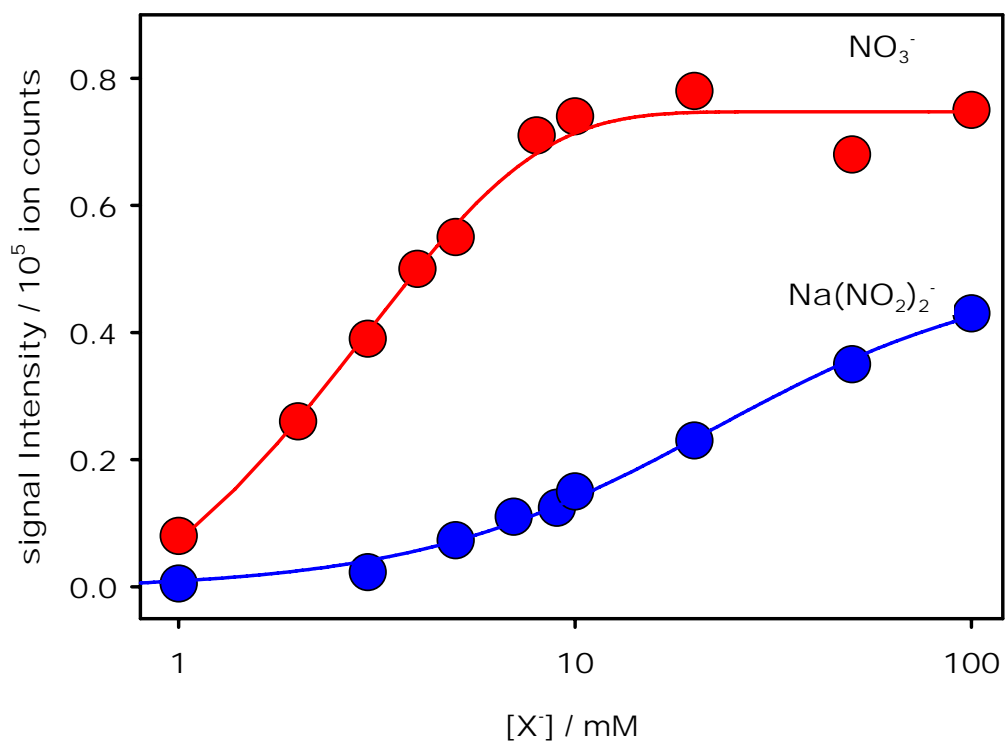

Figure S3. $m/z = 62$ (NO_3^-) and 115 [$\text{Na}(\text{NO}_2)_2^-$] signal intensities vs. $[\text{X}] = [\text{NaNO}_3]$ or $[\text{NaNO}_2]$ over an extended concentration range showing saturation above 100 mM

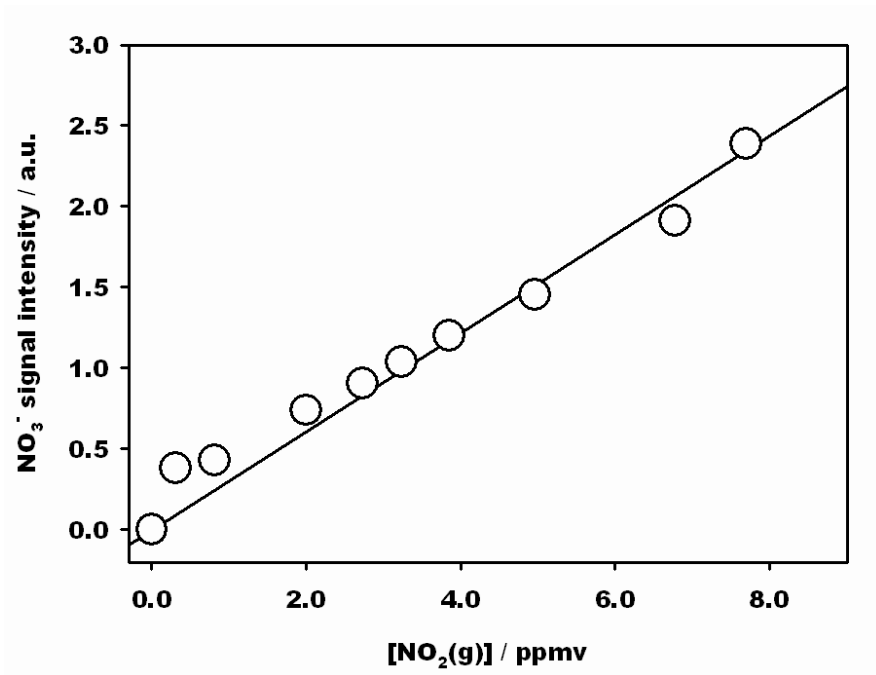

Figure S4. A plot of NO_3^- ($m/z = 62$) signal intensity as a function of $\text{NO}_2(\text{g})$ mixing ratio on 1mM NaCl pH ~ 7 microdroplets.

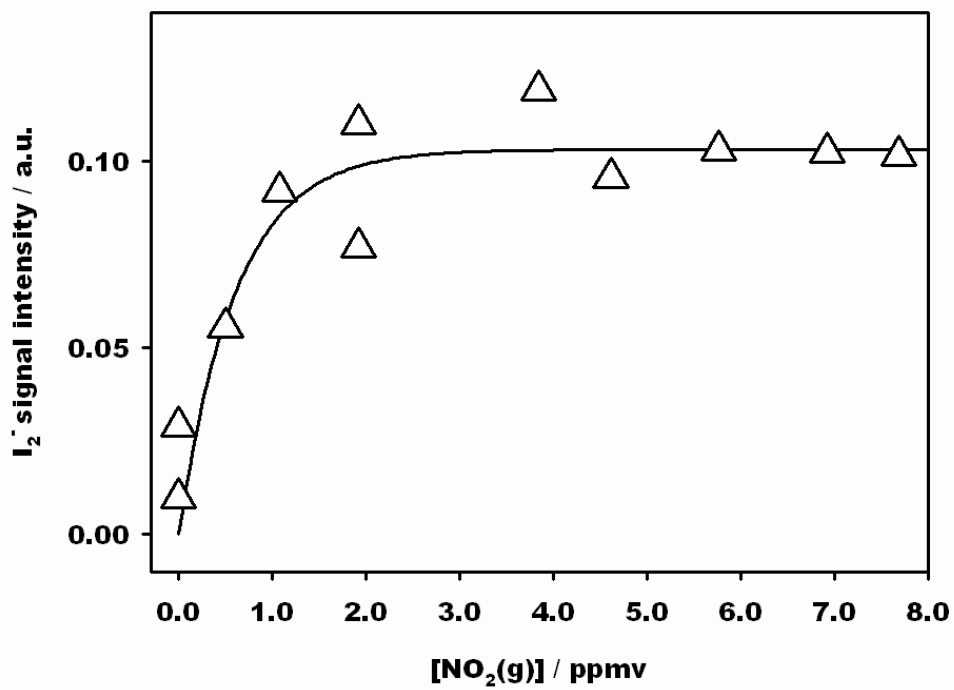

Figure S5. I₂⁻ (m/z = 254) signal intensity as a function of NO₂(g) mixing ratio on 1mM NaI pH ~ 7 microdroplets.

Supporting references

- 1 Fenn, J. B. *J. Am. Soc. Mass Spectrom.* **1993**, *4*, 524.
- 2 Kebarle, P.; Peschke, M. *Anal. Chim. Acta* **2000**, *406*, 11.
- 3 Yamashita, M.; Fenn, J. B. *J. Phys. Chem.* **1984**, *88*, 4451.
- 4 Yamashita, M.; Fenn, J. B. *J. Phys. Chem.* **1984**, *88*, 4671.
- 5 Enami, S.; Hoffmann, A. R.; Colussi, A. J. *J. Phys. Chem. B* **2008**, *112*, 4153.
- 6 Enami, S.; Hoffmann, M. R.; Colussi, A. J. *Proc. Natl. Acad. Sci. U.S.A.* **2008**, *105*, 7365.
- 7 Enami, S. *et al. J. Phys. Chem. A* **2007**, *111*, 8749.
- 8 Enami, S. *et al. J. Phys. Chem. A* **2007**, *111*, 13032.
- 9 Enami, S. *et al. Chem. Phys. Lett.* **2008**, *455*, 316.
- 10 Kahen, K.; Jorabchi, K.; Gray, C.; Montaser, A. *Anal. Chem.* **2004**, *76*, 7194.
- 11 Orphal, J. *J. Photochem. Photobiol. A-Chem.* **2003**, *157*, 185.