

Syracuse University

**SURFACE**

---

Architecture Senior Theses

School of Architecture Dissertations and  
Theses

---

Spring 2017

## **IIID: A Detailed Look into System Integration of Material Types Through the Use of 3D Printing**

Johnathon E. Phillips

Follow this and additional works at: [https://surface.syr.edu/architecture\\_theses](https://surface.syr.edu/architecture_theses)



Part of the [Architecture Commons](#)

---

### **Recommended Citation**

Phillips, Johnathon E., "IIID: A Detailed Look into System Integration of Material Types Through the Use of 3D Printing" (2017). *Architecture Senior Theses*. 409.

[https://surface.syr.edu/architecture\\_theses/409](https://surface.syr.edu/architecture_theses/409)

This Thesis, Senior is brought to you for free and open access by the School of Architecture Dissertations and Theses at SURFACE. It has been accepted for inclusion in Architecture Senior Theses by an authorized administrator of SURFACE. For more information, please contact [surface@syr.edu](mailto:surface@syr.edu).

A DETAILED LOOK INTO SYSTEM INTEGRATION OF MATERIAL TYPES THROUGH THE USE OF 3D PRINTING

---

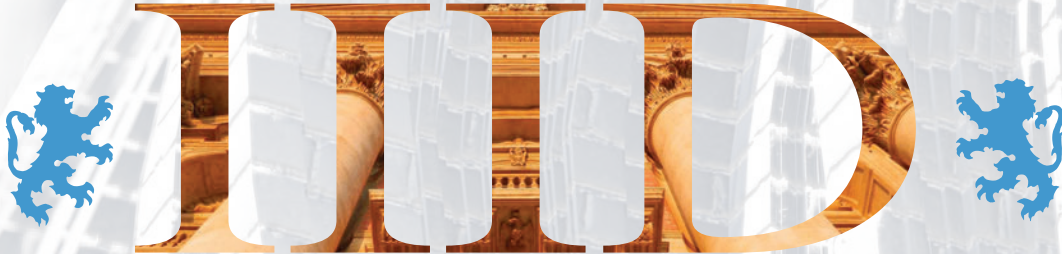

# BLOCK METRIC FABRICATION

---

BACHELOR OF ARCHITECTURE, SYRACUSE UNIVERSITY, 2016 THESIS PREPARATION  
JOHNATHON E. PHILLIPS

# Contents

Thesis Introduction	Page 1
Quotes	Page 2
Research	Page 4
Precedent Studies	Page 12
Development Optimization	Page 21
Design Pavilions	Page 34
Renders	Page 48
Business Development	Page 54
Historic Preservation	Page 59
Conclusion	Page 68
Citations	Page 70

## Thesis Introduction

The use of 3D printing technology as a means in which to produce building materials is now bemoaning a reality. This tool, which can create highly detailed and sculpted objects, can be used in pioneering new ways to create spaces with virtually an infinite amount of detail. By understating the processes in which these designs can occur and the materials which will be used to fabricate those concepts we can develop spaces with hyper densification of detail; those at the forefront dealing with overall form and spatial composition and continuing down in scale until no longer visible to the human eye.

This thesis wishes to pursue the potential of 3D printing ornamented designs with the use of shale/clay powder. This material compound, through this research, had been shown to be compliable wit 3D printing technology so that it can be sculpted by the tools of the architect into complex geometric “blocks.” These can then be printed and fired allowing them to become the tectonic building bricks for a new way of building. Through researching this material, I will demonstrate the usefulness and possibilities of this time-tested substance in the creation of new architectural spaces.

By producing highly sculpted architectural elements that interlock at both low cost and in a short amount of time, we could begin to bring these conceptual spaces not only into the built environment for architects but for the broader audience; for all those within the built environment. With the use of Shale rock found throughout the upstate area we can substitute the more commonly used materials in powder printing and, through iteration, develop bricks with compressive strengths equal to that of industry standard load barring bricks. 3D printing is used heavily for quick generation of prototype designs throughout the fields of architecture and engineering, as well as many other professions. With a multi-bed configuration, it will be possible to achieve mass production of objects quickly.



# QUOTES

# QUOTES

"When the spangled turf is wet with dew and the mist from the water is veiling the sundered walls; when the sun rides high and the mellow stone glows deep and golden, whilst deep shadows lurk under the transept vaults; when the light is level at sunset and the grassy pavement is slashed with golden bars; in sun and shadow, in mist or rain, is the very haunt of our poetry, a dream like emanation of the past, set here on the verge of the insistent, clamorous present."

-Ralph Adams Cram  
1863-1942

"In architecture, digital fabrication tools allow us to bring back complex forms and systems of ornament that previously were prohibitively expensive and time consuming. They let us work at the threshold of haptic and visual perception."

- Michael Hansmeyer  
Tools of Imagination

"The astounding growth that our resources have undergone in terms of their precision and adaptability will in the near future confront us with very radical changes indeed in the ancient industry of the beautiful... Neither matter nor space nor time is what it always was. We must be prepared for such profound changes to alter the entire technological aspects of the arts, influencing invention itself!"

- Paul Valery  
Pieces Sur L'Art. 1931

Oh what a tangled web we weave,  
When first we practise to deceive!

-Sir Walter Scott  
Marmion, Canto vi. Stanza 17.

"The western waves of ebbing day rolled o'er the glen their level way; each purple peak, each flinty spire, was bathed in floods of living fire. But not a setting beam could glow within the dark ravines below, where twined the path in shadow hid, round many a rocky pyramid, shooting abruptly from the dell its thunder-splintered pinnacle; round many an insulated mass, the native bulwarks of the pass, huge as the tower which builders vain presumptuous piled on Shinar's plain. The rocky summits, split and rent, formed turret, dome, or battlement. Or seemed fantastically set with cupola or minaret, wild crests as pagod ever decked, or mosque of Eastern architect. Nor were these earth-born castles bare, nor lacked they many a banner fair; for, from their shivered brows displayed, far o'er the unfathomable glade, all twinkling with the dewdrop sheen, the briar-rose fell in streamers green, kind creeping shrubs of thousand dyes waved in the west-wind's summer sighs."

-Sir Walter Scott  
The Lady of the Lake, First Canto, 11th Stanza



# RESEARCH

# MATERIAL STUDIES

Shale is the term given to clay rich sedimentary rocks. These rocks form about 60% percent of the stratigraphic column and are about 50%–60% clay by weight. The material composition of shale is typically made up of the following minerals: QUARTZ, FELDSPAR, CARBONATE, FE-OXIDES, CLAY MINERALS, OTHER MINERAL, AND ORGANIC MATTER.

	SHAW AND WEAVER	HILLIER
QUARTZ	30.8%	23.9%
FELDSPAR	4.5%	3.7% (K-SPAR) 2.4% (PLAGIOCLASE)
CARBONATE	3.6%	7.5% (CALCITE) 1.3% (DOLOMITE) 0.5% (SIDERITE)
FE-OXIDES	0.5%	0.8%
CLAY MINERALS	60.9%	47.7% (DI-CLAY) 7.5% (TRI-CLAY)
OTHER MINERAL	2%	0.5% (PYRITE)
ORGANIC MATTER	1%	NOT DETERMINED

**QUARTZ:** Chemical Composition  $SiO_2$  Uses include glass making, abrasive, and foundry sand

**FELDSPAR:** include a range of compositions with a general chemical formula of  $xAl(Al,Si)_3O_8$  where x can be sodium (Na) and/or calcium (Ca) and/or potassium (K)

**CARBONATE:** a salt of the anion  $CO_3^{2-}$ , typically formed by reaction of carbon dioxide with bases

**FE-OXIDES:** Iron(III) oxide or ferric oxide is the inorganic compound with the formula  $Fe_2O_3$

**CLAY MINERALS:** Phyllosilicates, or sheet silicates, form parallel sheets of silicate tetrahedra with  $Si_2O_5$  or a 2:5 ratio

**ORGANIC MATTER:** Younger Clays have lignin and humic acids present, while older clays contain carbonaceous and bituminous substances



## Step I: Machine Setup

The purpose of this machine is to assist in research by layer integration and penetration of binding agents within given powdered materials so as to test the structural capabilities of those objects it produces. This process of binding layers together, much like the stacking of topographic layers on a site model, is fundamental to the integrity of the object. This process wishes

## Step II: Template Insert

In Diagram 2 we see that a template is inserted into the template tray. These templates act as the negatives which form the contours of the object being assembled within the machine. Each section of the build will have its own unique template which will be able to inform the shape of the object as it is assembled. In this example a rectangular brick is being produced, so the template shape will not change as the object builds vertically on the build tray.

## Step III: Template Lock

Once the Template is inside the template jig it will be secured by clamping down the lid. This lid is to maintain the position of the template so as to insure that the templates fall to the same position each time a new layer is to be applied. So that the object as a whole doesn't end up looking like the layers didn't line up, this feature was added as an extra precision device.

## Step IV: Plate and Boom

Here, the build plate and the reservoir plate are both moved vertically; the reservoir plate moves up. This movement upwards will expose a layer of powder to the top tray of the build plate. Once that layer is exposed it will be boomed across onto the build plate. The build plate will then fill with the one layer of powder material because at the same time that reservoir plate moved up the build plate moved down, both at in an equal and opposite direction vertically. This is done so as to insure the same amount of material is deposited over each layer as the build process continues.

## Step V: Placing of Template

The template plate is now slide directly over top of the build plate at which point it will be stopped by a guide so as to insure accuracy over several layers. This template is then locked in place and is ready for the next step.

## Step VI: Applying Binding Agent

Here is where the material will be bound to itself through the process of applying a binding agent to the areas opened up by the template plates. The binding agent will be tested in different application method in several different ways to study the effects of those different methods on the objects integrity and durability. The agent itself used for fusing the layers together will be experimented on and changed to view the same results.

# NANGONITE

SHALE MINERAL DEPOSITS EXTRACTED FROM SOUTHERN CHENANGO COUNTRY. HIGH BODY CONCENTRATIONS OF IRON AND CLAY

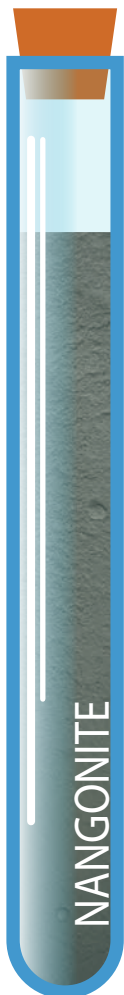
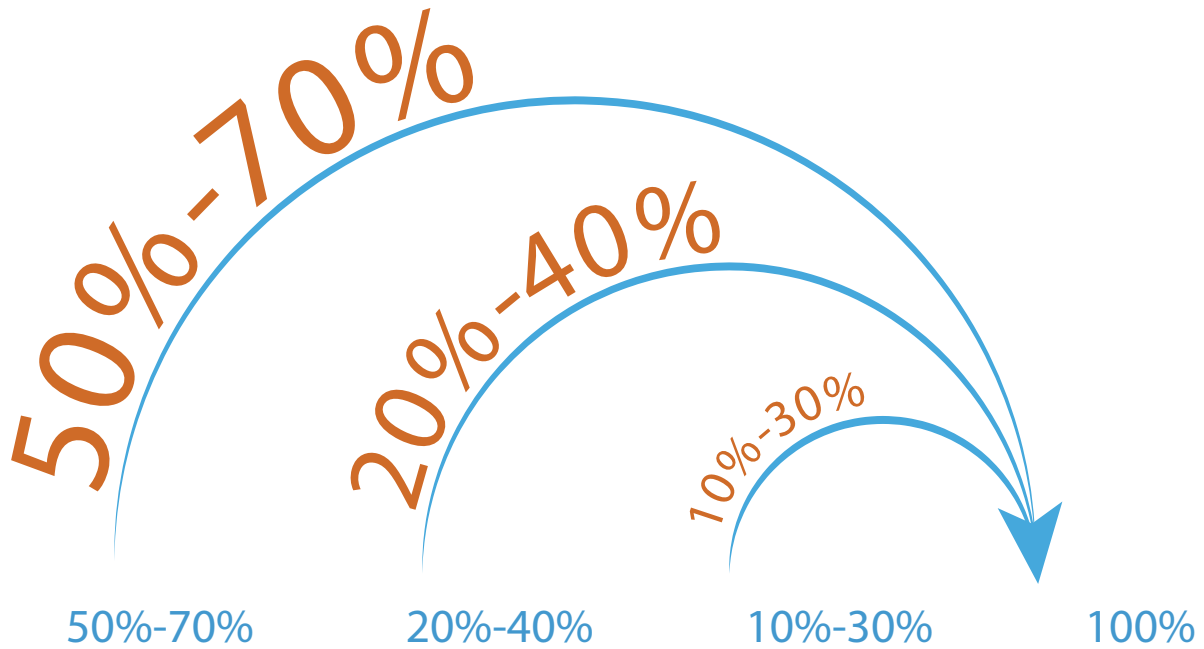

This shale powder comprises the body of the compound, forming the base clay content and adding strength with its aggregates.

**BODY**  
MATERIAL

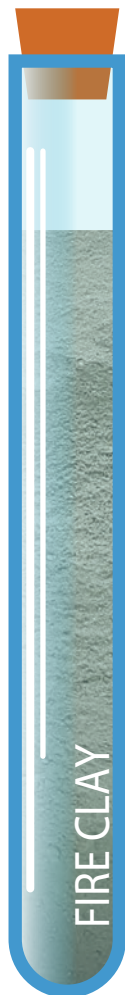

Fire clay consists of previously **fired brick** that can be remolded and **fired again**, creating a material that can tolerate extreme temperatures variants.

**PROPERTIES**  
THERMAL & ABSORPTIVE

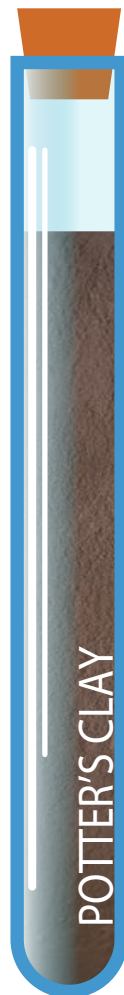

Potter's clay has is a **refined** mineral substance that is added to the compound to increase the overall sheet silicate count. This helps bind the brick material when it's **being fired**.

**STRUCTURE**  
BINDING AND COLOR AGENT

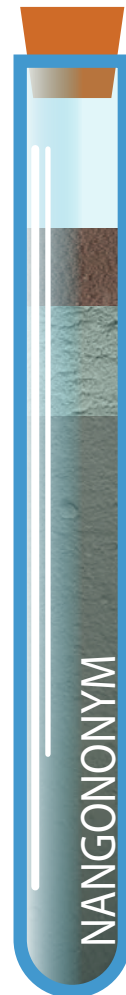

Nangonym: A compound which consists of approximately 50%-70% Nangonite, a 20%-40% clay concentrate (potter's clay), and 10%-30% refractory material (**fire** clay).

**COMPOUND**  
COMBINED MATERIAL AGENTS

# INDUSTRY DEVIATION

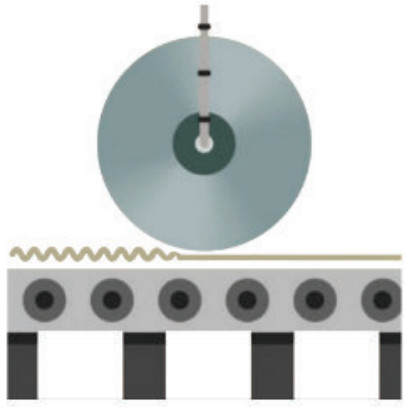

**Step 1:** The unrefined material is brought in and pulverized into a consistent powder

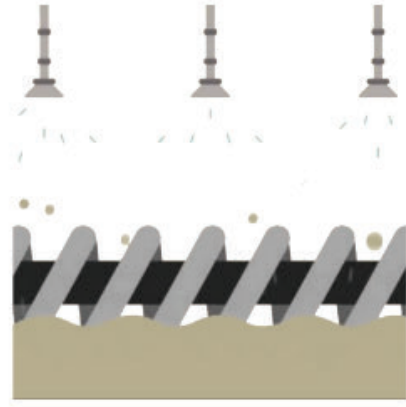

**Step 2:** The Refined powder is then mixed to create a stiff slurry that which is pliable and can be molded into shape

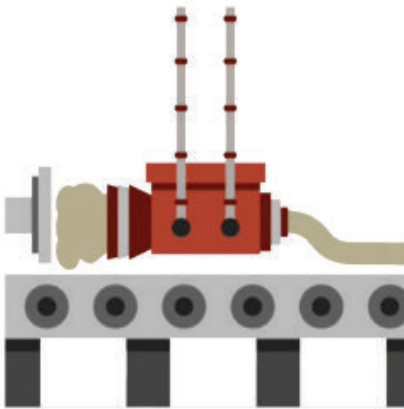

**Step 3:** The now wet mixture is extruded through a die to form bricks

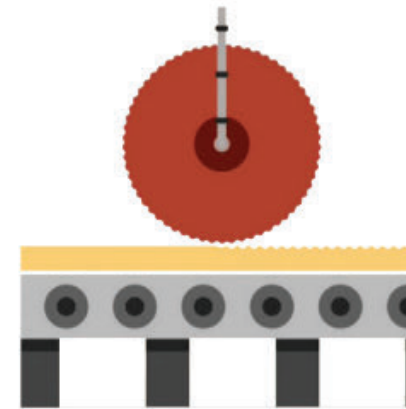

**Step 4:** The rectangular block then has a custom surface added to it

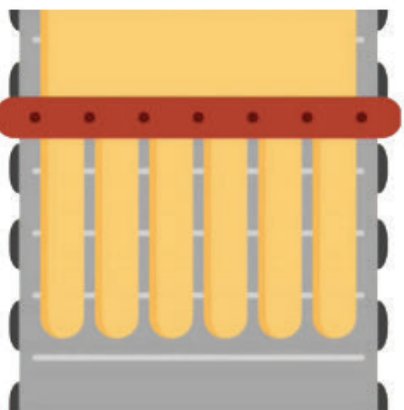

**Step 5:** The block is then Split into individual bricks

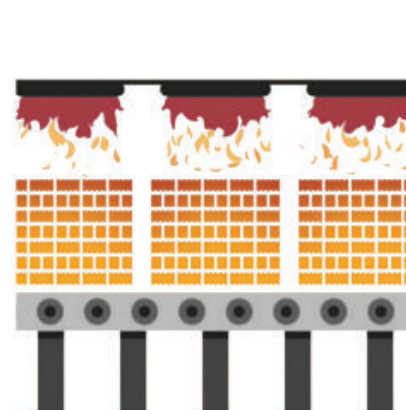

**Step 6:** The bricks are then fired so as to complete the process of brick production

# PERCENTAGES OF COMPOUND MATERIAL



5 - 25% KAOLINITE



10 - 30% ALKALI METAL SALTS



40 - 75% FRIT + OTHER MATERIALS

# POTTERS CLAY SIEVE TESTING

0.5 Inches



Sieve level 1: Cull material is sifted from the clay body to make pure the sample material and break down larger pieces from entering the refining stages as the material process continues.

Sieve level 2  
0.2500 Inches



Sieve level 2: Now that the excess material is separated from the clay body the process of reducing material really size begins. Here smaller particles are separated from those larger elements that screened through the first pass.



## Sieve level 3 0.1640 Inches



Sieve level 3: This third step is crucial. Here the material, at its second to last phase is vigorously shook to detach any previously bond dust particles and smaller pieces so as to process them later on in sieving step number 4



## Sieve level 4 0.0082 Inches



Sieve level 4: Sieve level 4: particulates within clay powder mixture are now .0041" or smaller. Grain size is now compatible with 3d binder jetting.



# PRECEDENT STUDIES

# Digital Grotesque



“We aim to create an architecture that defies classification and reductionism. We explore unseen levels of resolution and topological complexity in architecture by developing compositional strategies based on purely geometric processes.

In the Digital Grotesque project, we use these algorithms to create a form that appears at once synthetic and organic. The design process thus strikes a delicate balance between the expected and the unexpected, between control and relinquishment. The algorithms are deterministic as they do not incorporate randomness, but the results are not necessarily entirely foreseeable. Instead, they have the power to surprise.”



# Inhotim Monolith



“Where does nature end and the artificial begin?”

As visitors wander through the lush nature of Inhotim, they face an unexpected encounter: a marble monolith, several meters high, firmly planted amidst the flora.

Something is amiss. The monolith appears neither to be part of the environment, nor to be detached from it.”

# Märchenwald

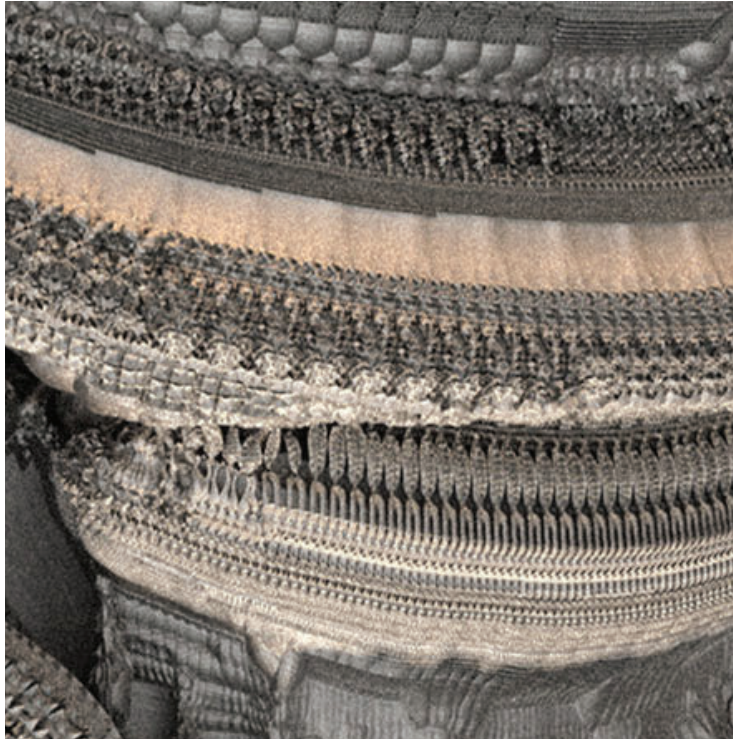

“Architecture overcomes the boundaries between natural and artificial worlds. In our pavilion a forest arises - a romantic landscape - composed of freely moving columns, grouped into ephemeral configurations of an ornamental wilderness. Freed from historical models, a space opens up for the visitors that disorients through a new sensory experience.”

# Columns



“This project involves the conception and design of a new column order based on subdivision processes. It explores how subdivision can define and embellish this column order with an elaborate system of ornament.

An abstracted doric column is used as an input form to the subdivision processes. Unlike the minimal input of the Platonic Solids project, the abstracted column conveys a significant topographical and topological information about the form to be generated. The input form contains data about the proportions of the the column's shaft, capital, and supplemental base. It also contains information about its fluting and entasis.”

# Curtain Wall



Medieval Tapestries. 1-2 Emerging Objects 3d Printed Pavilion 3. Digital Grotesque 4

# Mineral Divestment and Grading

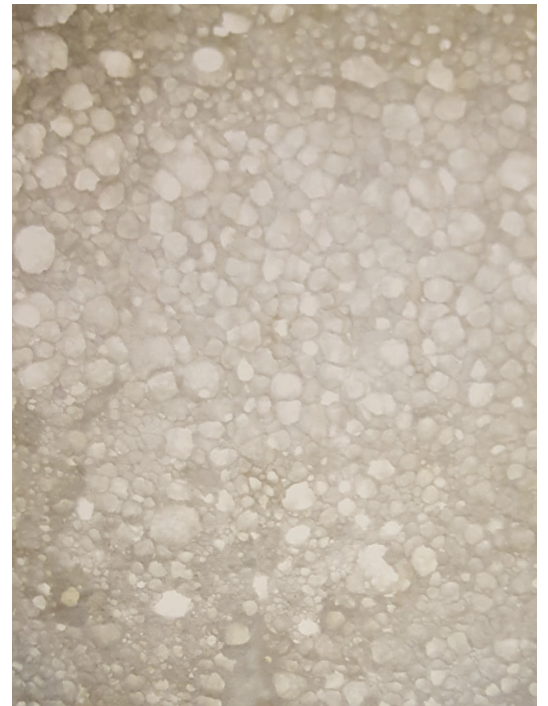
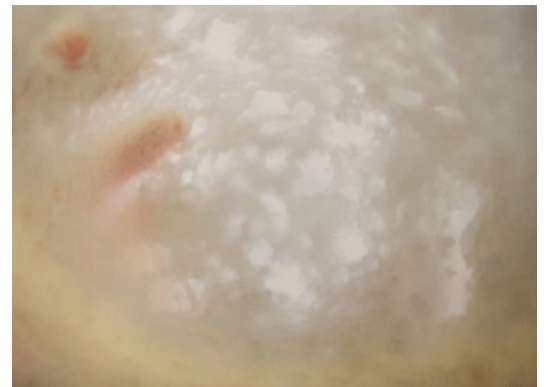

Foamed Ceramics: European Ceramic Work Center, Joris Laarman, Studio BV

# Vertical Air Distribution

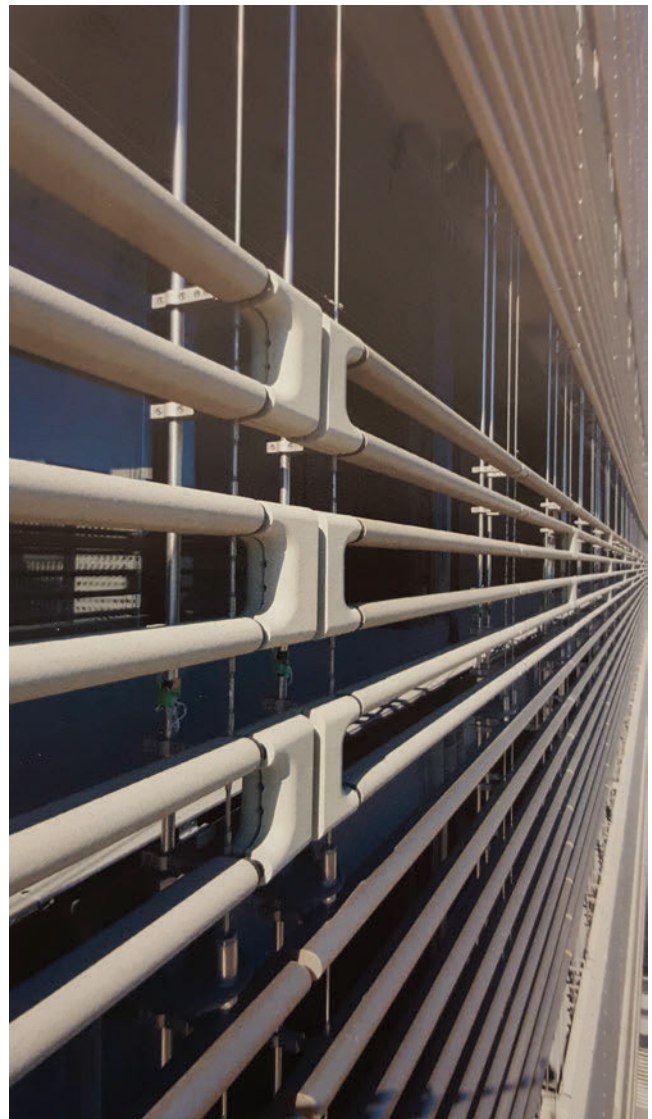
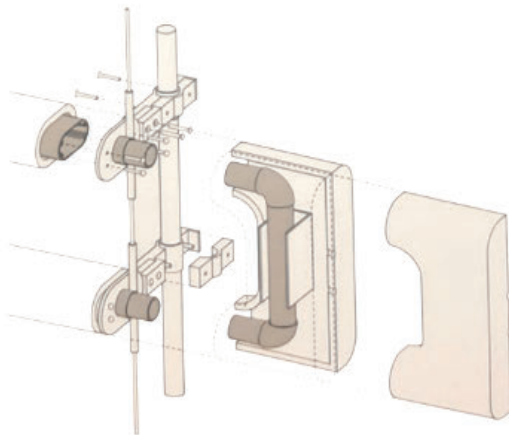
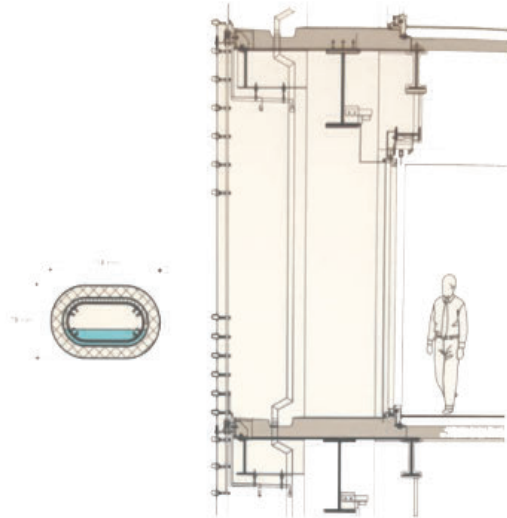

Bio Skin, Sony Research and Development Office, Tokyo, Japan

# Passive Cooling Systems

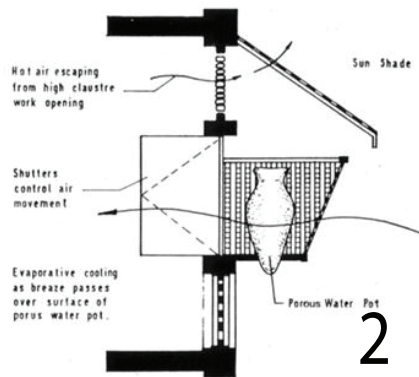
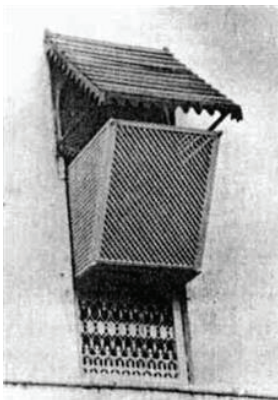
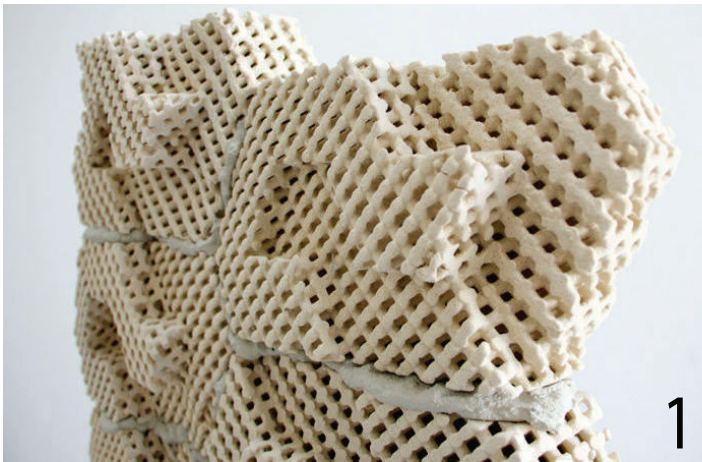

Tethon 3D's Rain Wall, Evaporative Cooling Ceramics (1). The Muscatese Window Diagram (2). Tethon 3D Ceramic Vorinoi Series (3). Michael Hansmeyer's Arabesque Wall (4).



# DEVELOPMENT OPTIMIZATION



## Section of Internal Optimized Materials

Optimization of evaporative surface is a key performative issue. With the research developed by Jared Friedman in his 2015 thesis proposal geometries across a surface can be optimized so as to exemplify evaporative cooling. In his studies, he sought the effect on vertical air flow through the placement of cylindrical rods. This can be transcribed into a surface exploration of the evaporative potentiality inherent within material types.

## Internally Generated Thermal Properties

“Foam production can occur with a mix of 5-25% kaolin-ite, 10-30% alkali metal salts and/or alkaline earth metal salts, 40-75% frit as well as other materials. After a low temperature drying phase, kiln firing at temperatures between 800C and 1,200C produces a rigid foamed material that expands approximately 300% compared to the solid bulk. Its density is 300-400 kg/m<sup>2</sup> which is considerably lower than that of solid ceramic work.” –Marjan van Aubel – Foamed Ceramics Ceramic Material Studies.

# Geometry Studies of Fractal Patterns

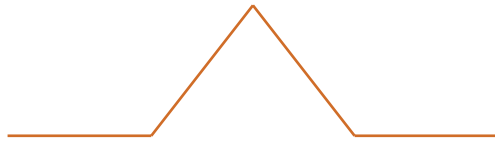

Recursion Factor: X1  
5 Curves



Recursion Factor: X2  
40 Curves



Recursion Factor: X4  
380 Curves



Recursion Factor: X16  
1,392 Curves

# Geometry Studies of Fractal Patterns



Recursion Factor: X1  
5 Curves

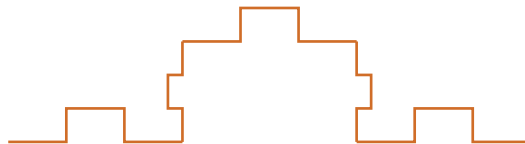

Recursion Factor: X2  
40 Curves

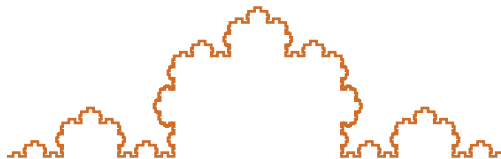

Recursion Factor: X4  
380 Curves

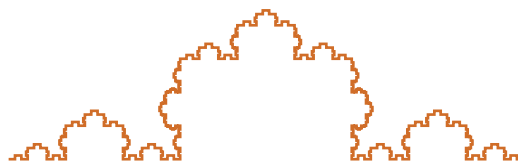

Recursion Factor: X16  
9,692 Curves

# Geometry Studies of Fractal Patterns

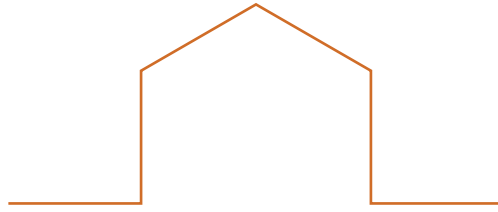

Recursion Factor: X1  
6 Curves

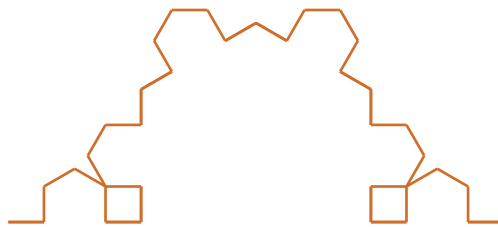

Recursion Factor: X2  
48 Curves

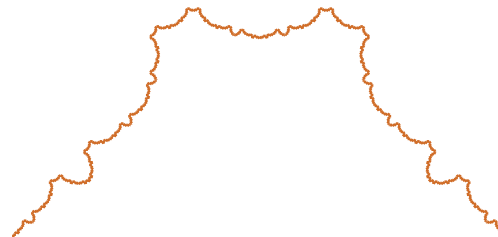

Recursion Factor: X4  
540 Curves

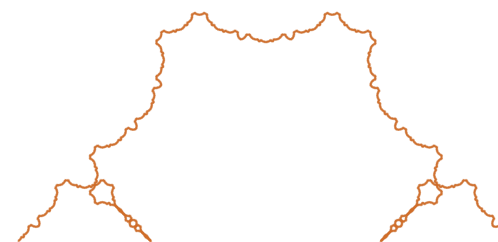

Recursion Factor: X16  
13,692 Curves

# Geometry Studies of Fractal Patterns



Recursion Factor: X1  
7 Curves



Recursion Factor: X2



Recursion Factor: X4  
1,041 Curves

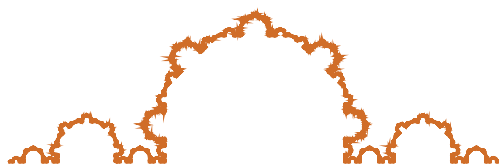

Recursion Factor: X16  
218,492 Curves

Radiant Wall Surface

Air Column  
Vertical  
Movement

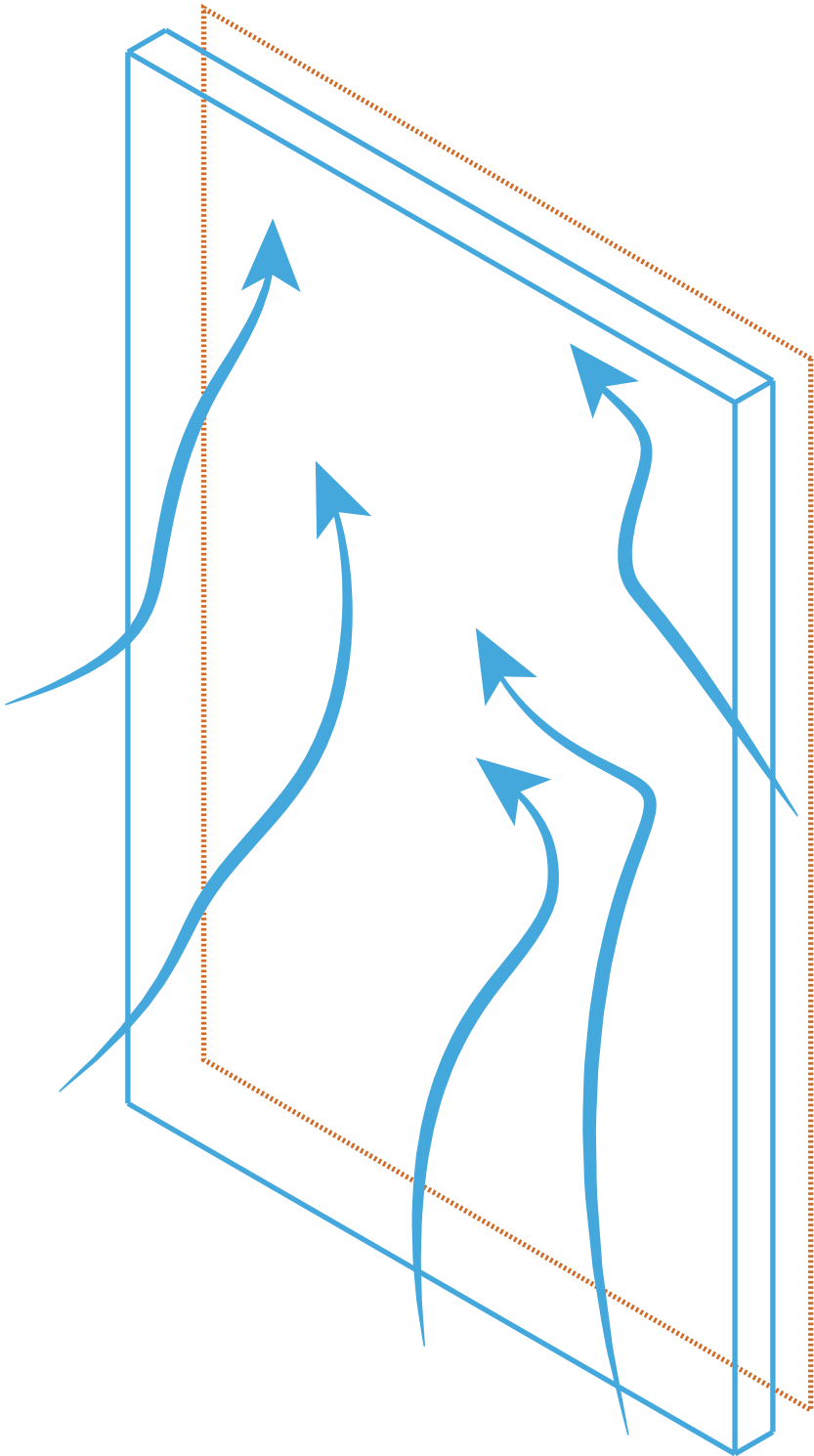

Flat Wall System

Radiant Wall Surface

Air Column  
Vertical  
Movement

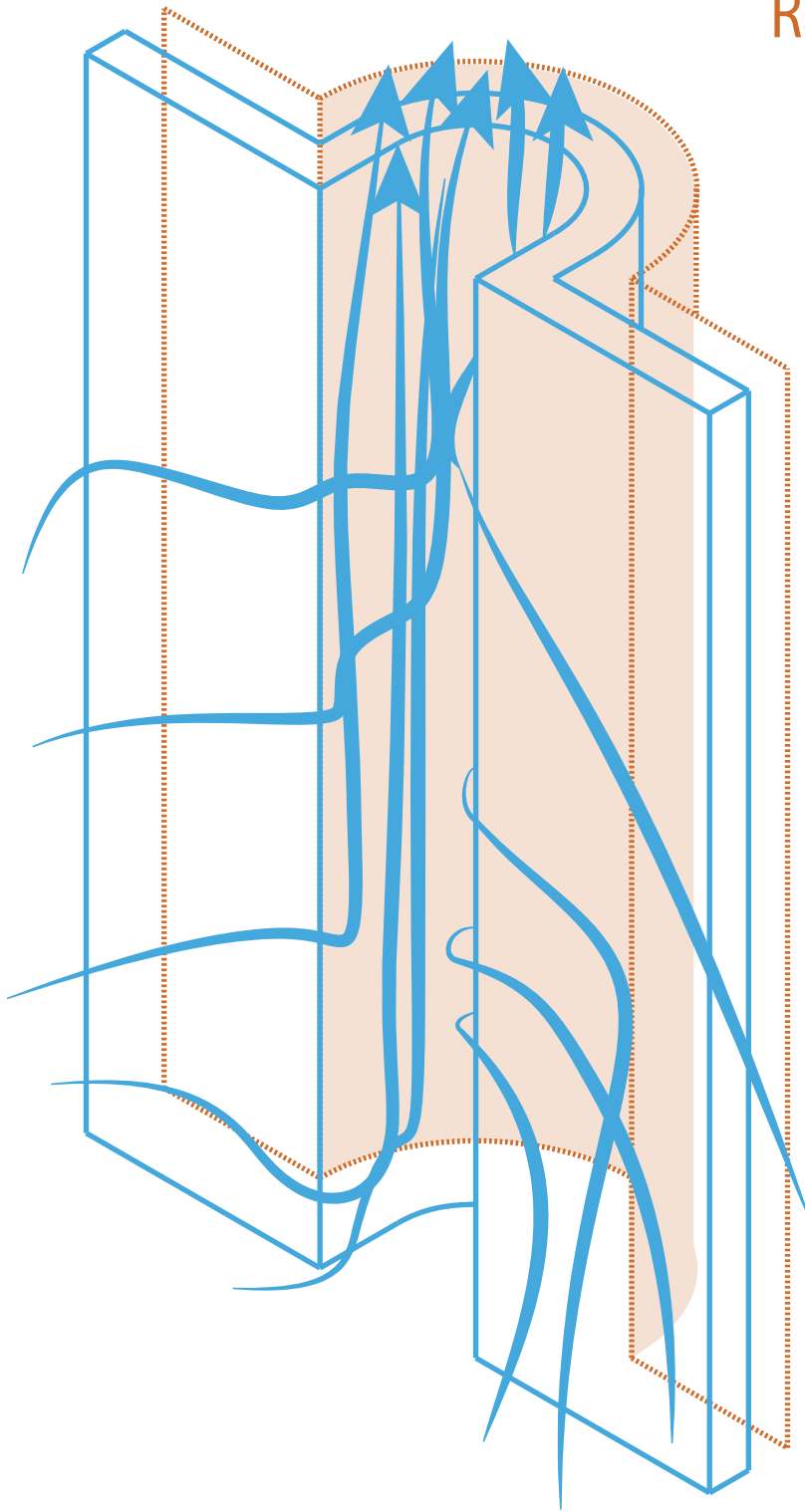

Articulated Wall System



# SECTIONAL RAIN SCREEN MORPHOLOGIES

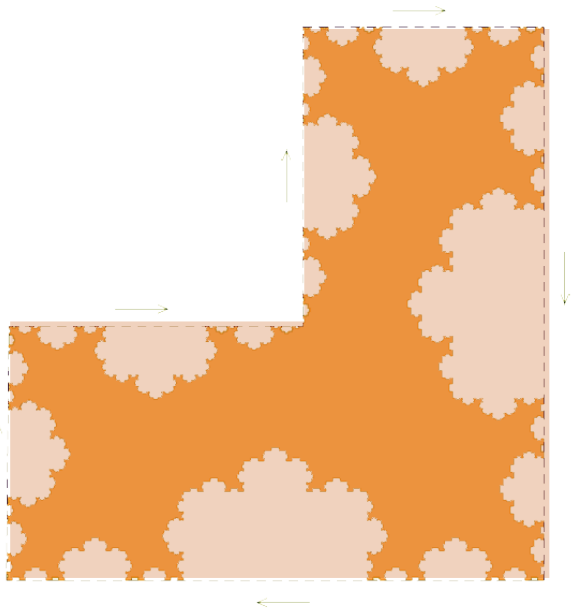

Interior

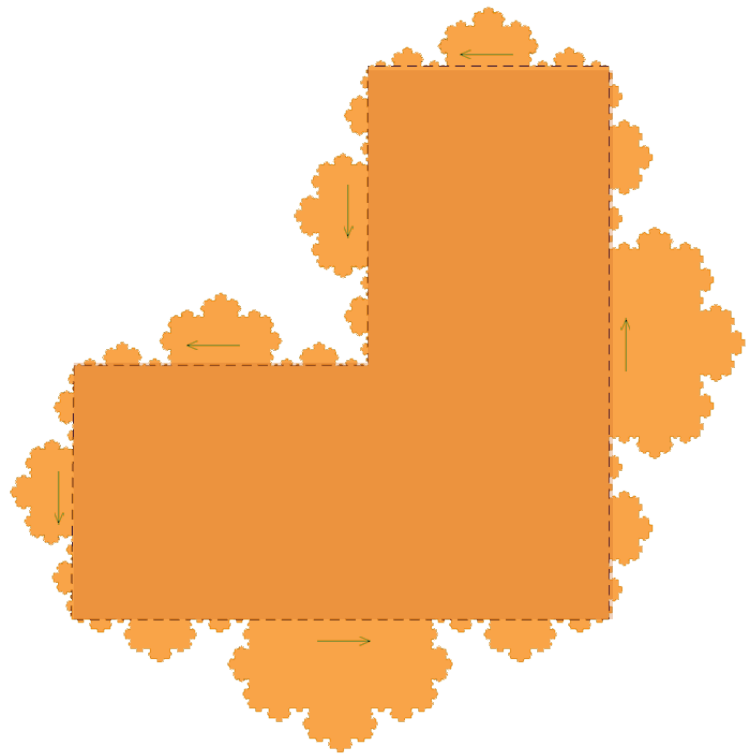

Exterior

# Section of Internal Optimized Materials

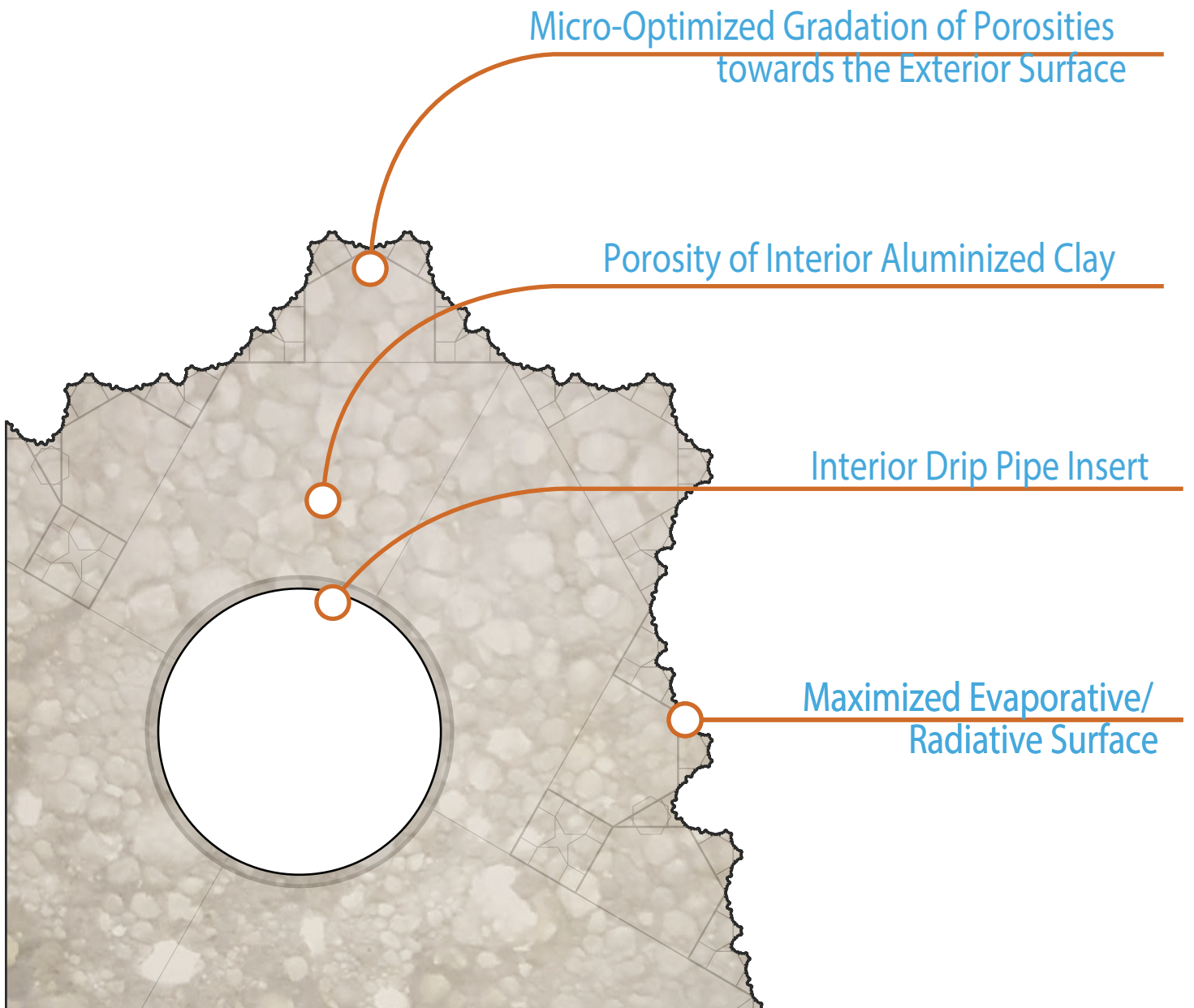

## Air Circulation Path Along Elevation of Surface

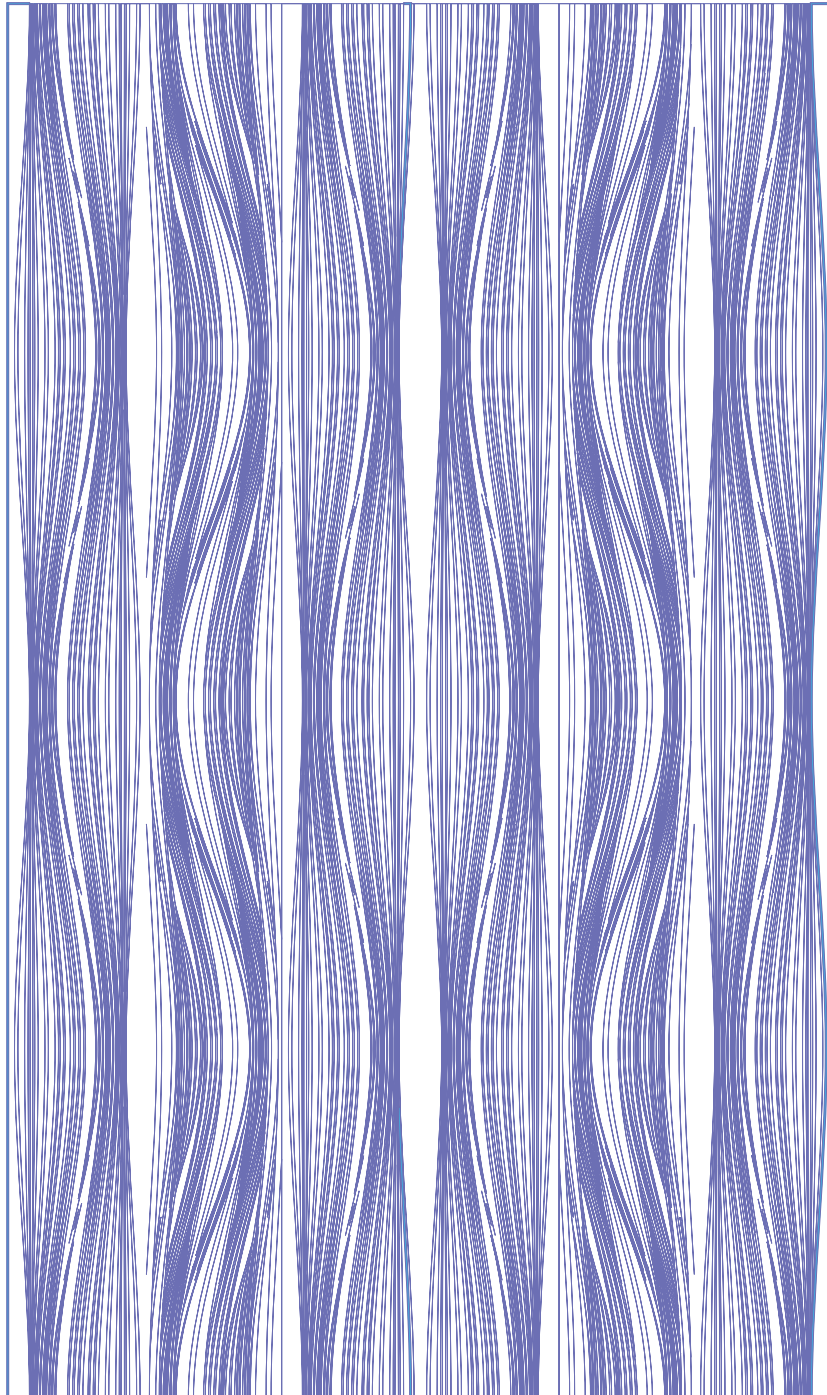

As density of air changes it naturally migrates vertically on a wall surface. By creating channels in which air can be heated and cooled **a system can be developed to encourage passive air flow through an entire room or space.**

# Geometry Studies of Fractal Patterns

Recursion Factor: X1

Recursion Factor: X2

Recursion Factor: X4

Recursion Factor: X16

Recursion Factor: X256

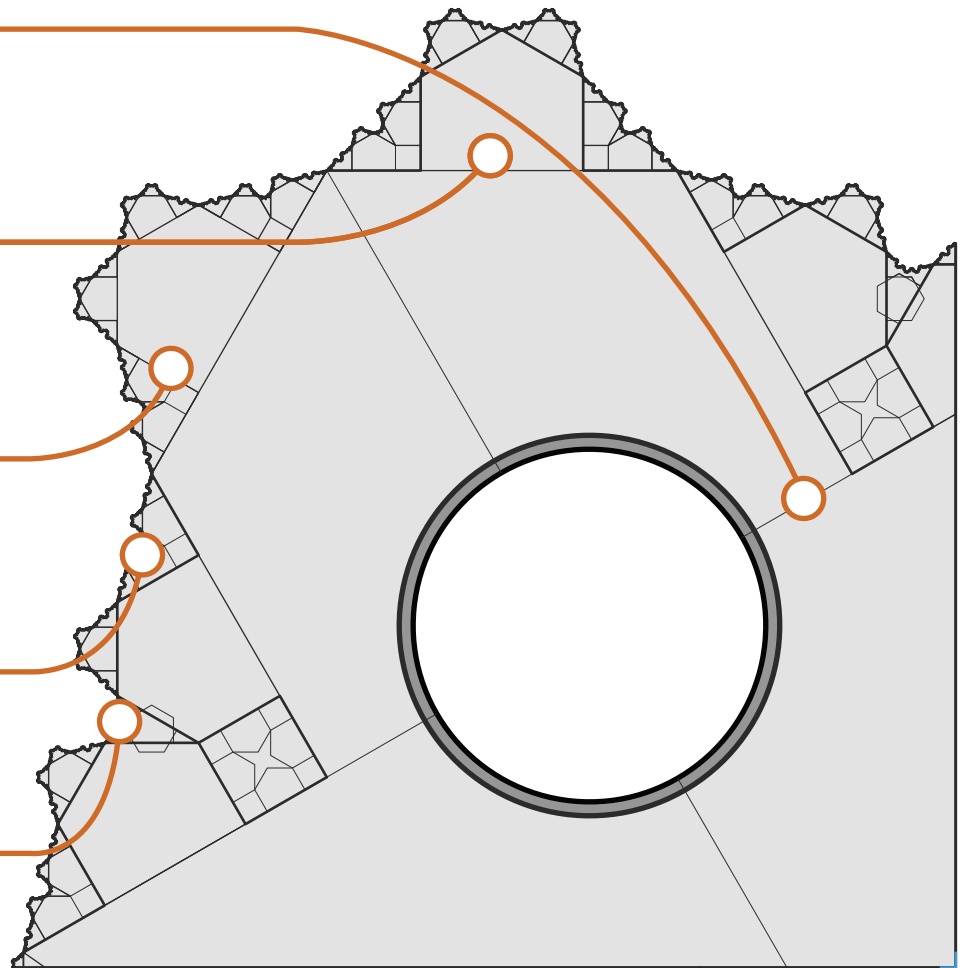



# DESIGN PAVILIONS

BRICK DIAGRAMS

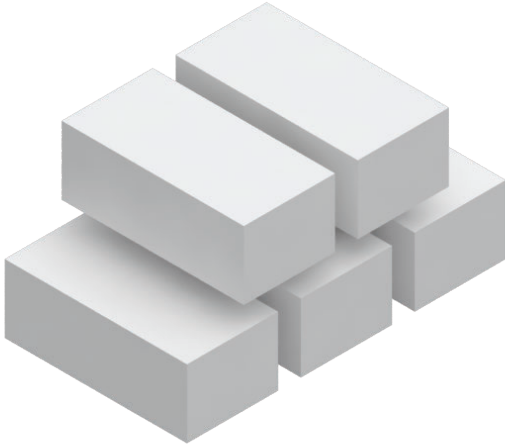

BRICK DIAGRAMS 1



BRICK DIAGRAMS 2

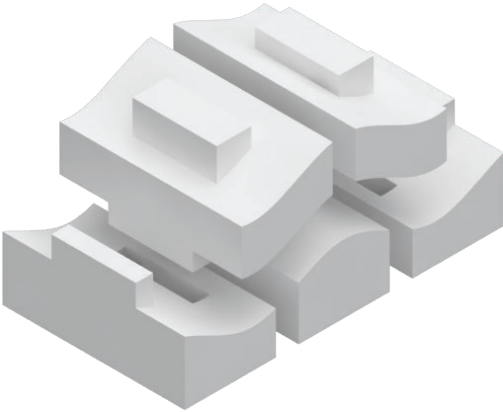

BRICK DIAGRAMS 3

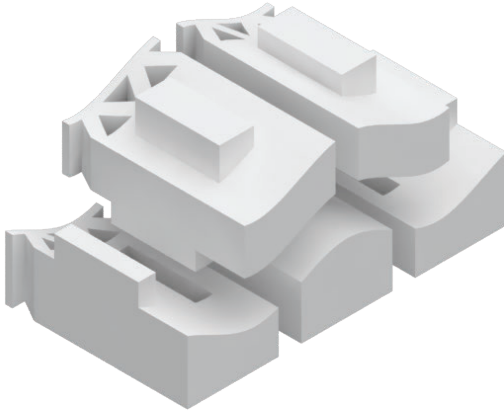

BRICK DIAGRAMS 4

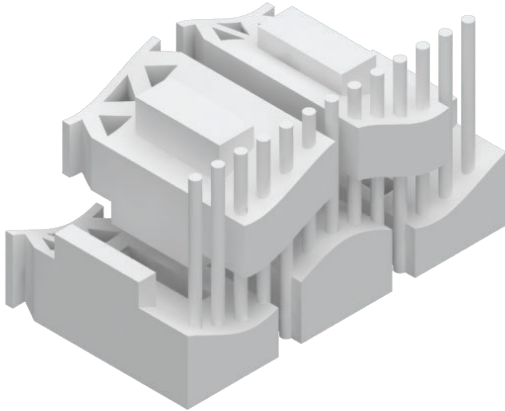

BRICK DIAGRAMS 5

# Diagrams of methods of iteration for vaulting research



1 BAY SYSTEM RIB VAULT

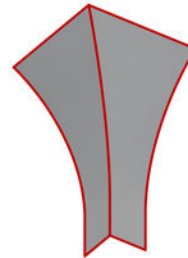

QUARTER BAY RIB VAULT

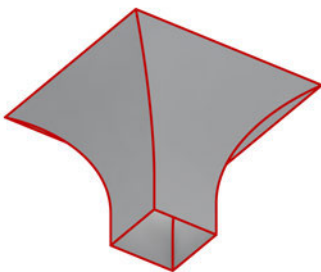

1 PIER OF RIB VAULT SYSTEM

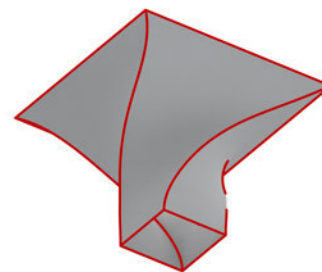

PIER ROTATED 90 DEGREES

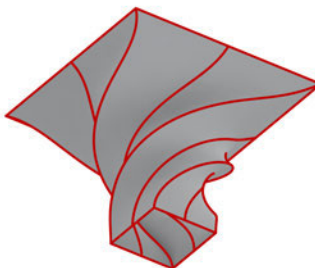

PIER ROTATED 90 DEGREES

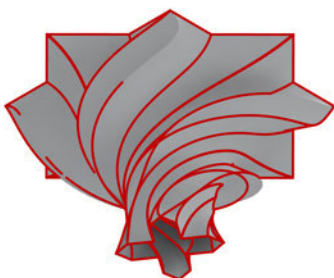
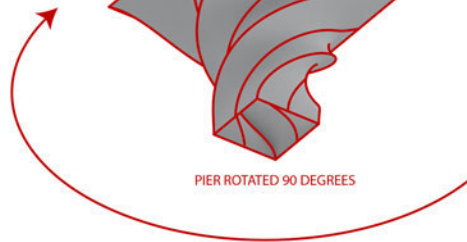

PIER ROTATED 90 DEGREES

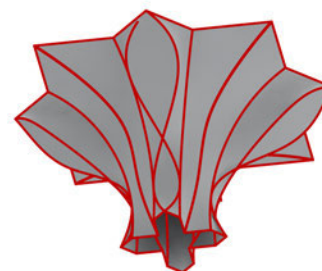
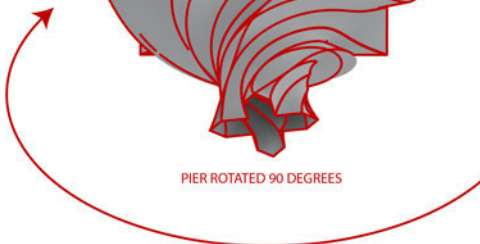

SURFACE ARTICULATION APPLIED TO PIER OF RIB VAULTING SYSTEM

## Iterations On Vaulting Systems

Twisting Studies And Fractal Geometric Integration/Applications

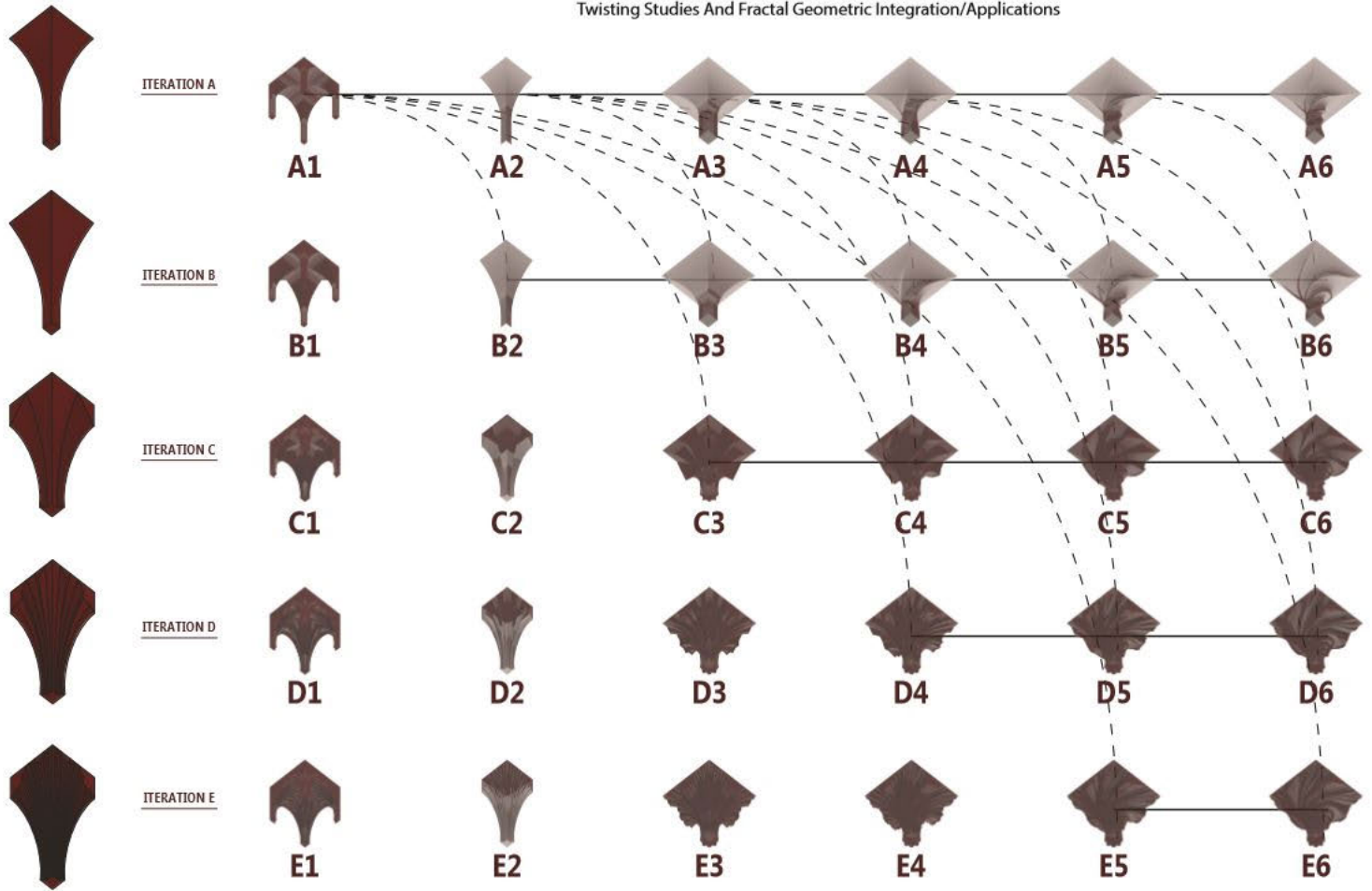

E6, being the most developed diagram is then transferred into the F then G stage to achieve an optimal resolution level. This object is then fit into a field of like columns which are then bound together, supporting one another and creating the pavilion.



### LOCKING SCARF JOINT

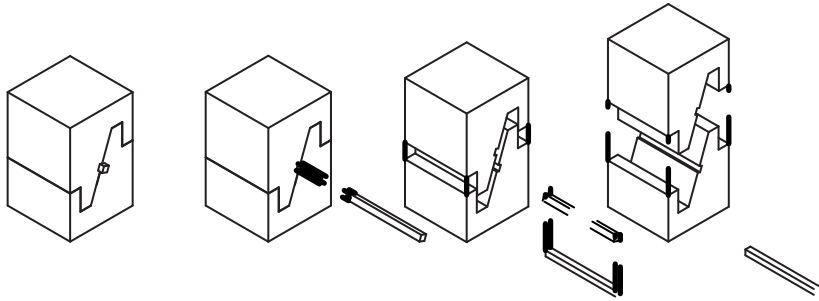

### KAWAI-TSUGITE CLOSED FITTING JOINT

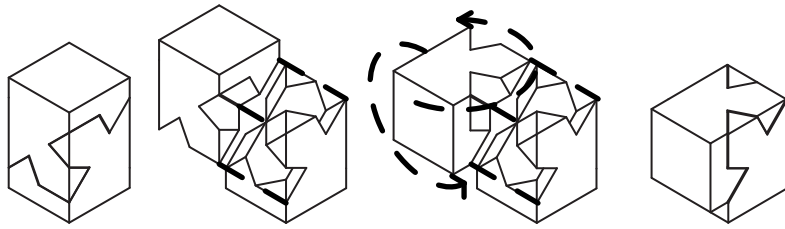

### GATE LOCKING JOINT

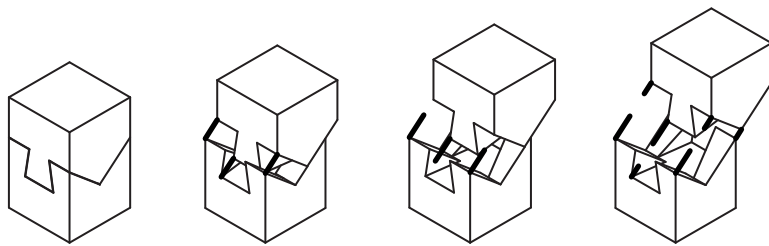

### INTERLOCKING FINGER JOINT

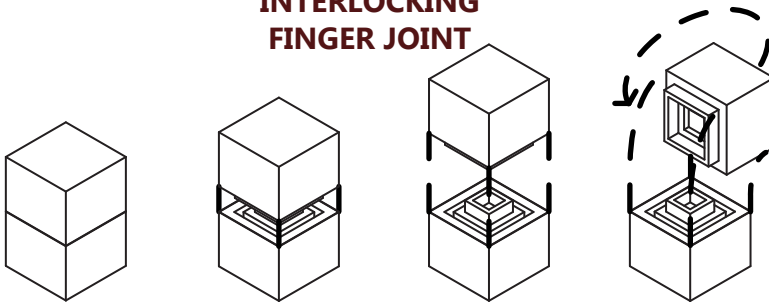

### INSET POST AND ADAPTER JOINT

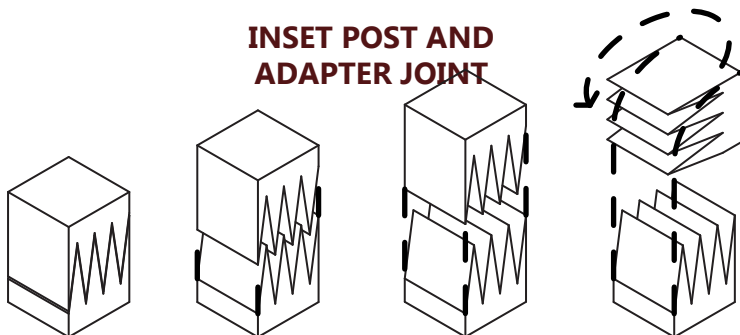

## Gate Lock And Pressure Joint Operation Within A Diagrammatic Archway

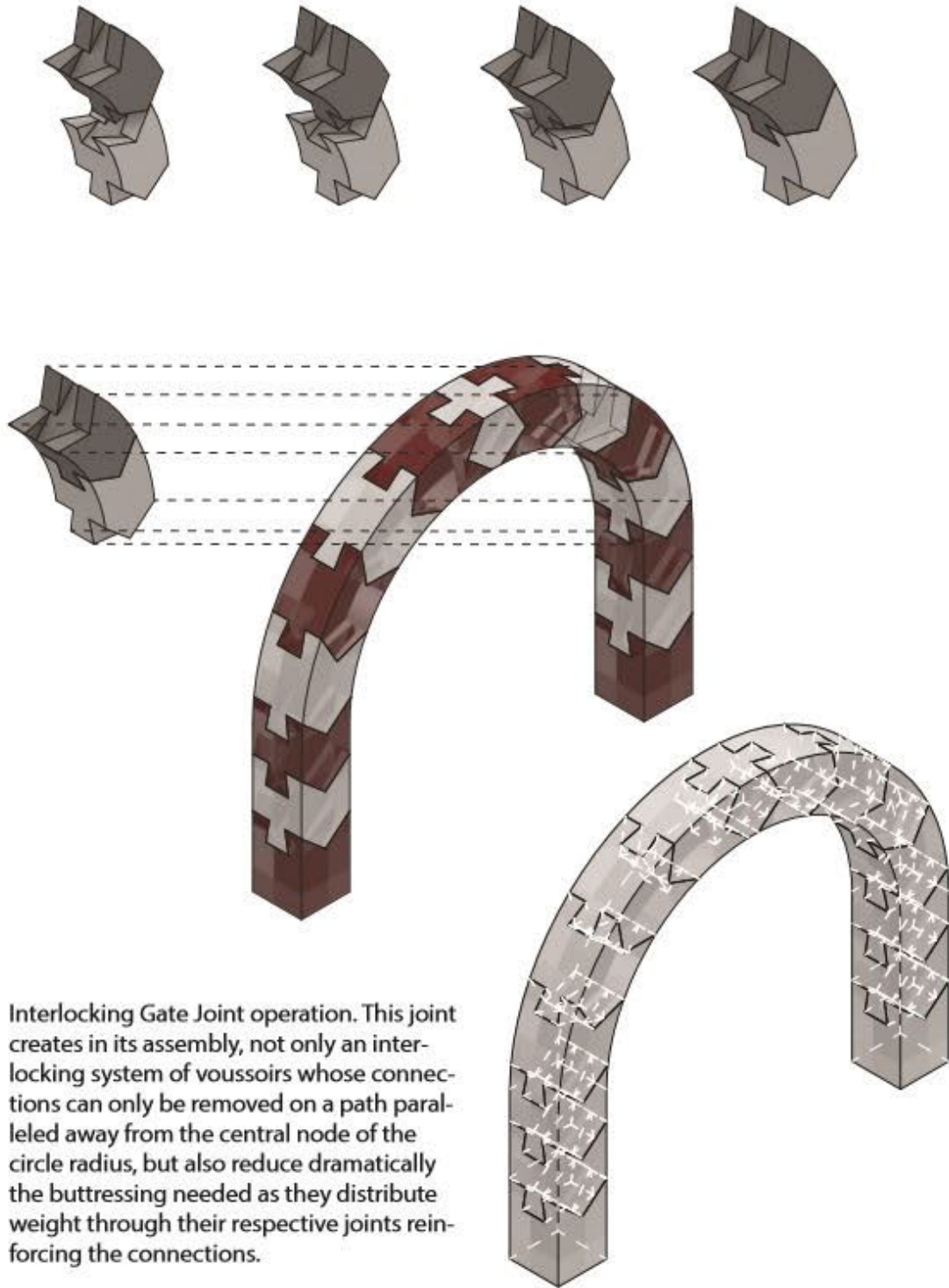

Interlocking Gate Joint operation. This joint creates in its assembly, not only an interlocking system of voussoirs whose connections can only be removed on a path paralleled away from the central node of the circle radius, but also reduce dramatically the buttressing needed as they distribute weight through their respective joints reinforcing the connections.

## Mixture Of Kaolinite And Bentonite Fire Clay In Distinguishing Layers Of Build Sec-

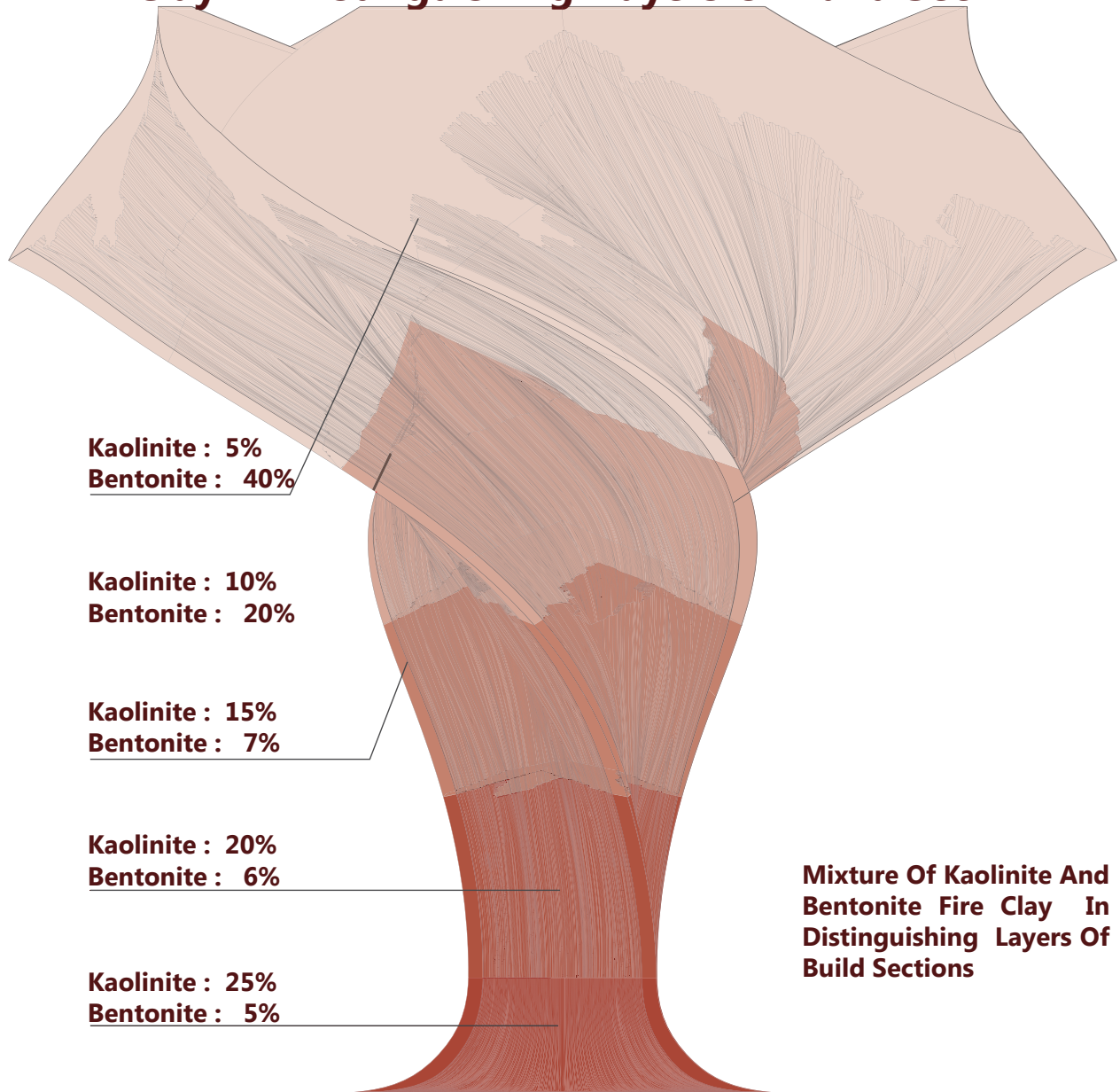

**Material Elevation**  
of column system

# 270 Degree Twisted Column Vault System

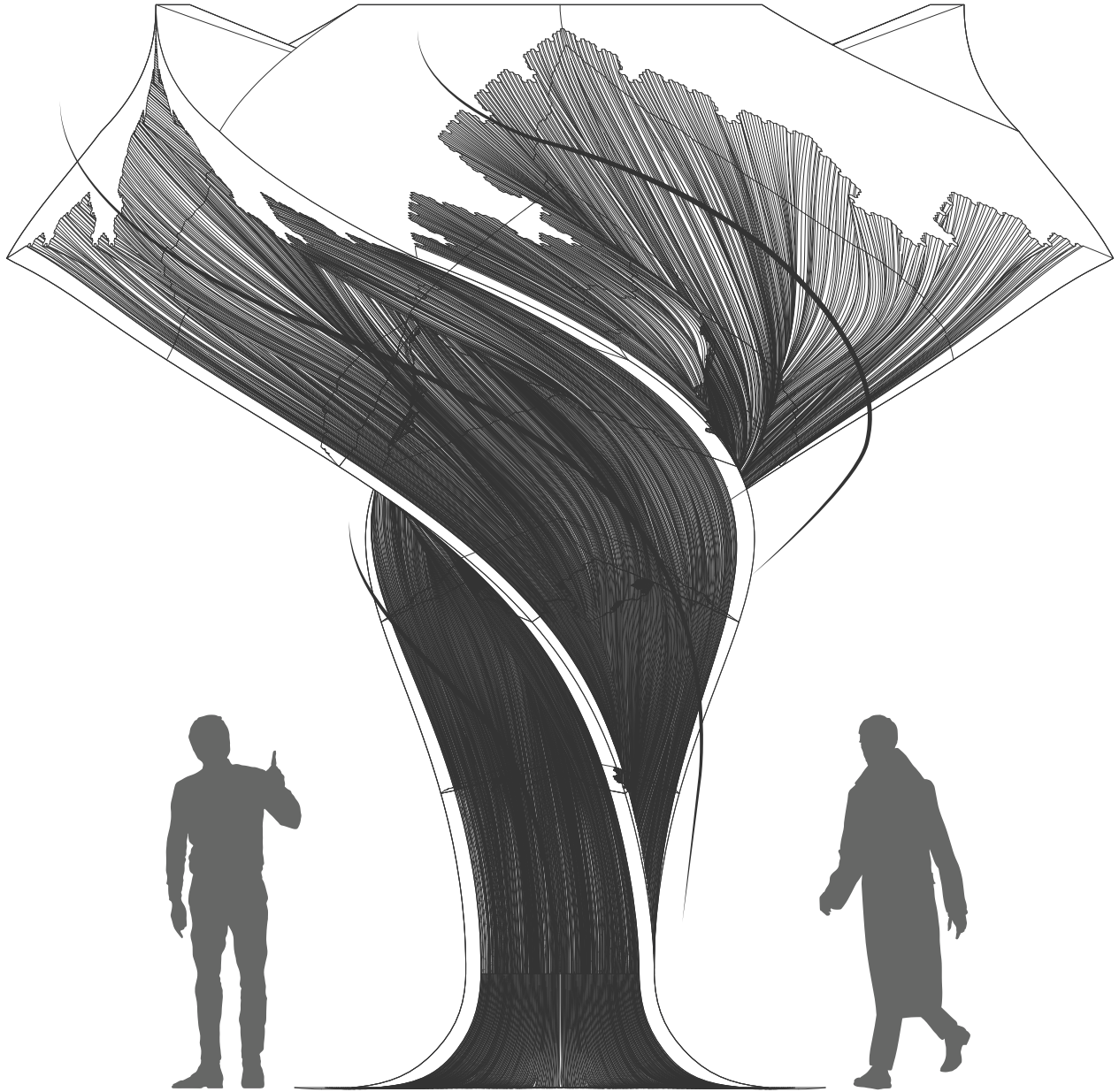

**Twisting Elevation**  
of column system



Diagram of brick material density

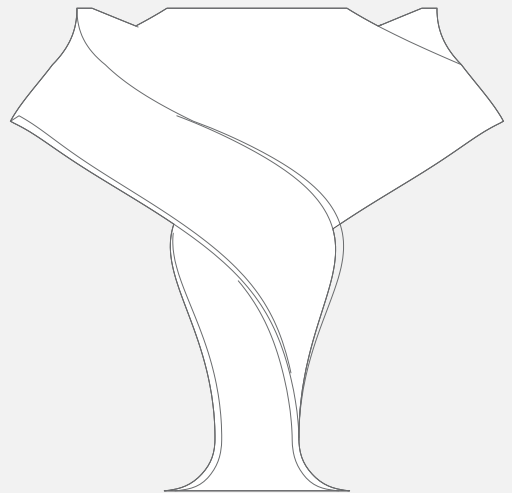

Diagram of spiral brick pattern



Rendered elevation of Brick Column system

Diagram of column block twist geometries



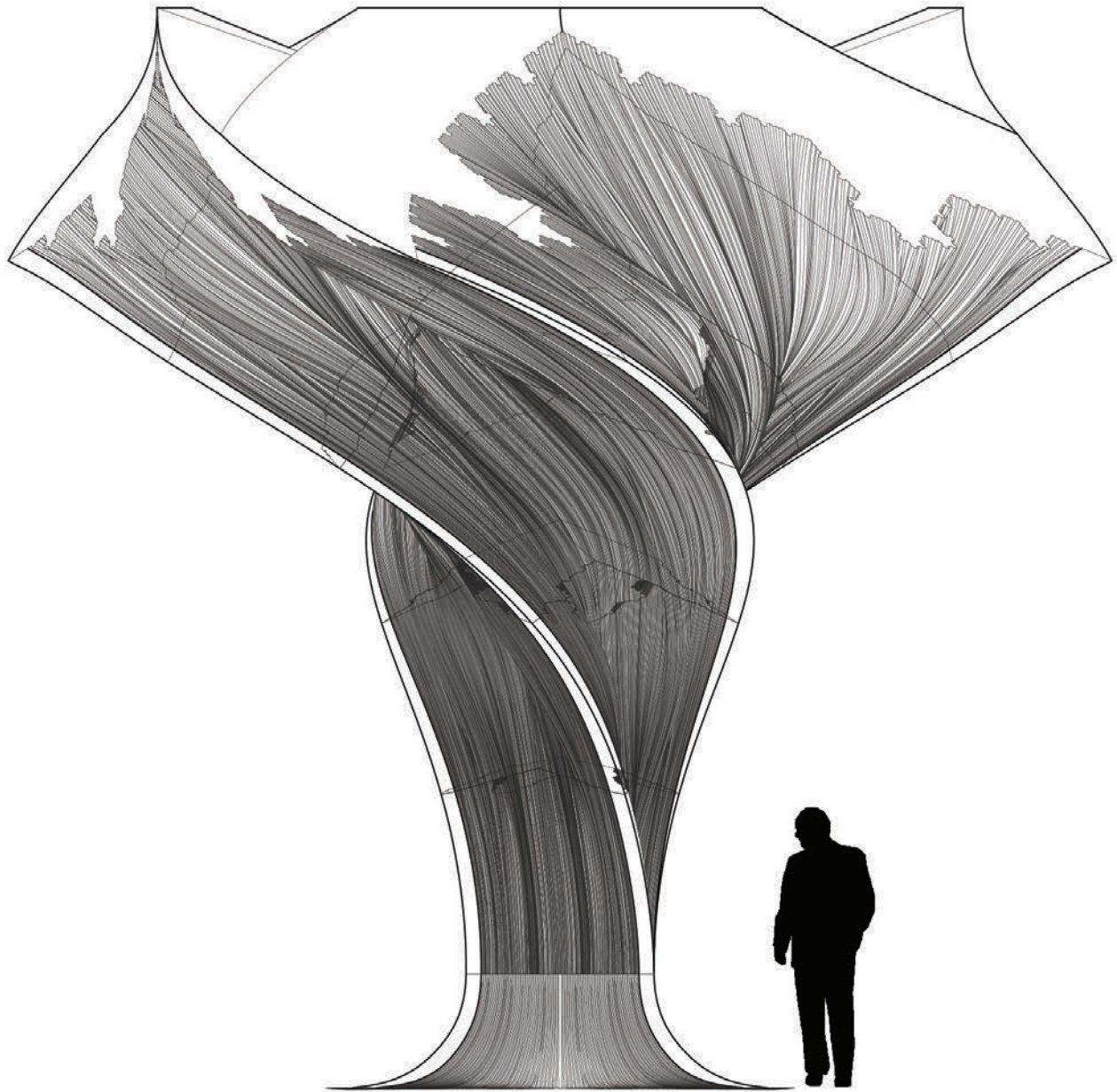

Tectonic Column Assembly. 180 degree twisted  
and interlocking brick column s ystem.

**Optimization of material  
through column structure**

**Secondary and Tertiary  
system integration in column**

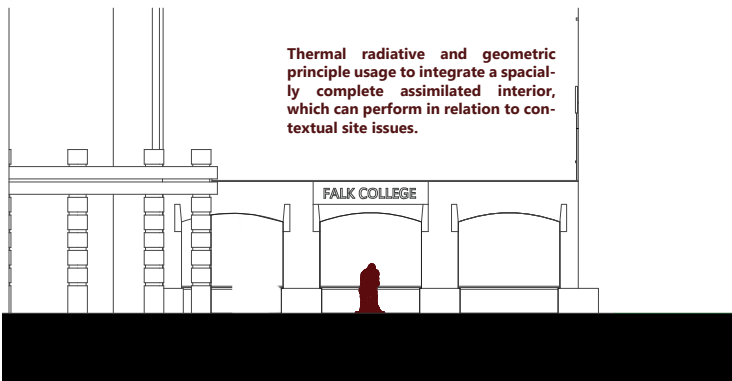
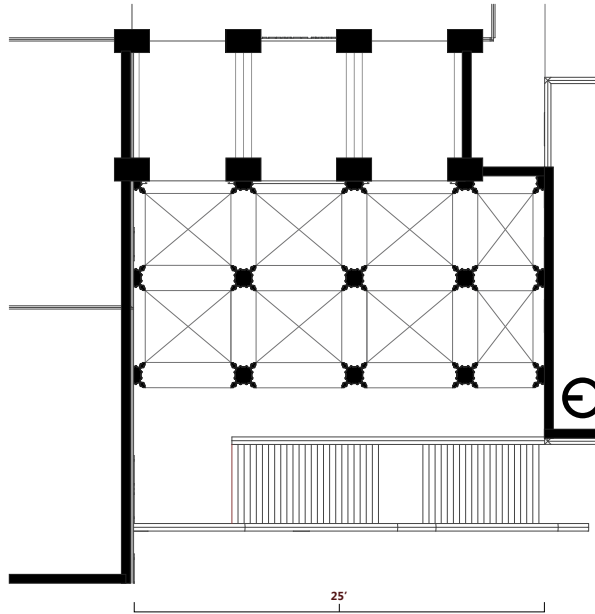

**West Elevation**

Thermal radiative and geometric principle usage to integrate a spatially complete assimilated interior, which can perform in relation to contextual site issues.

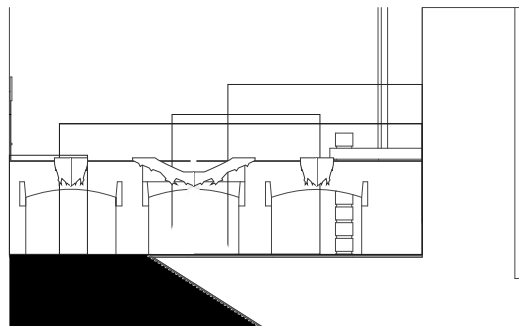

**East Elevation**



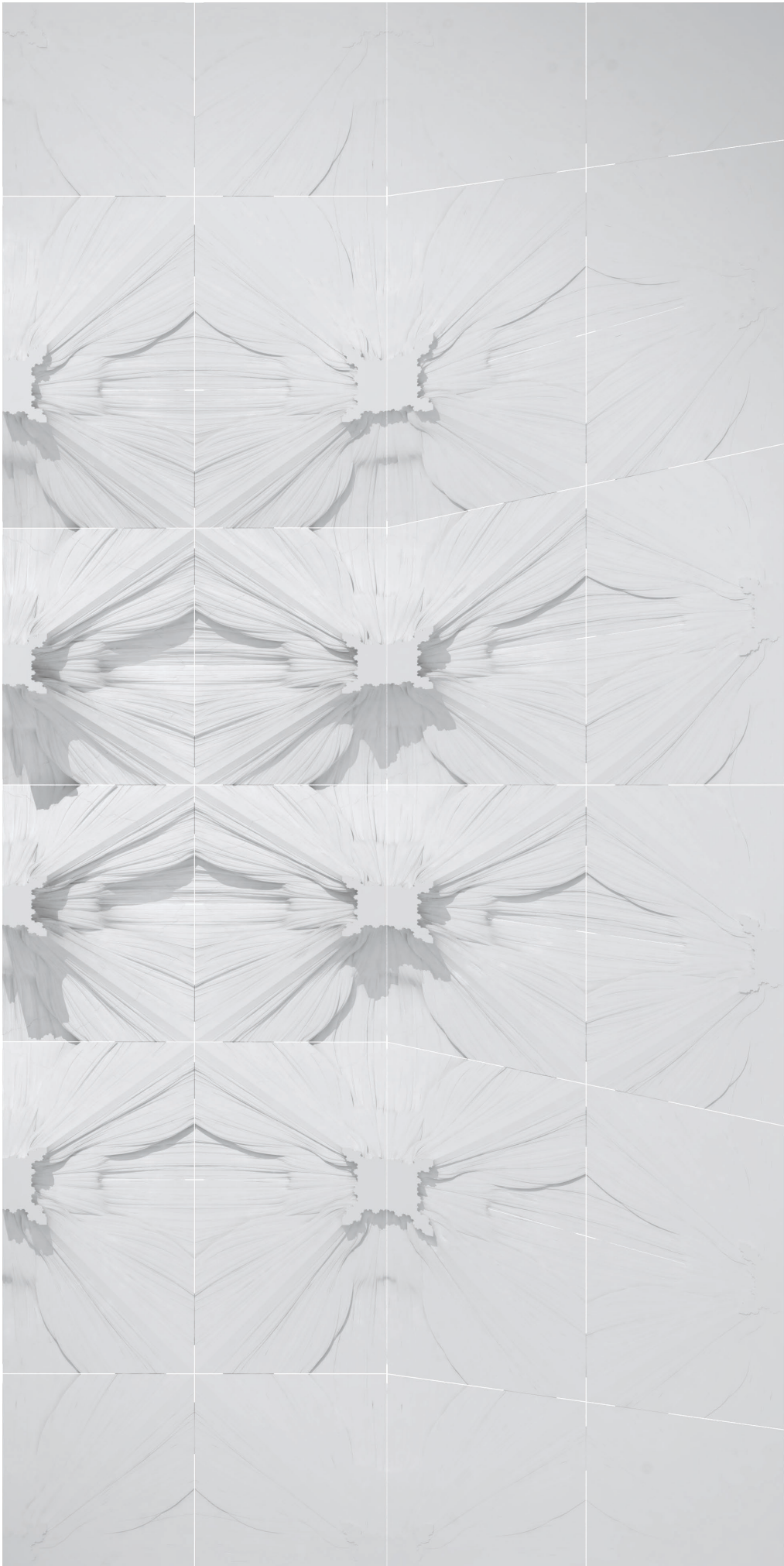

Ceiling Plan

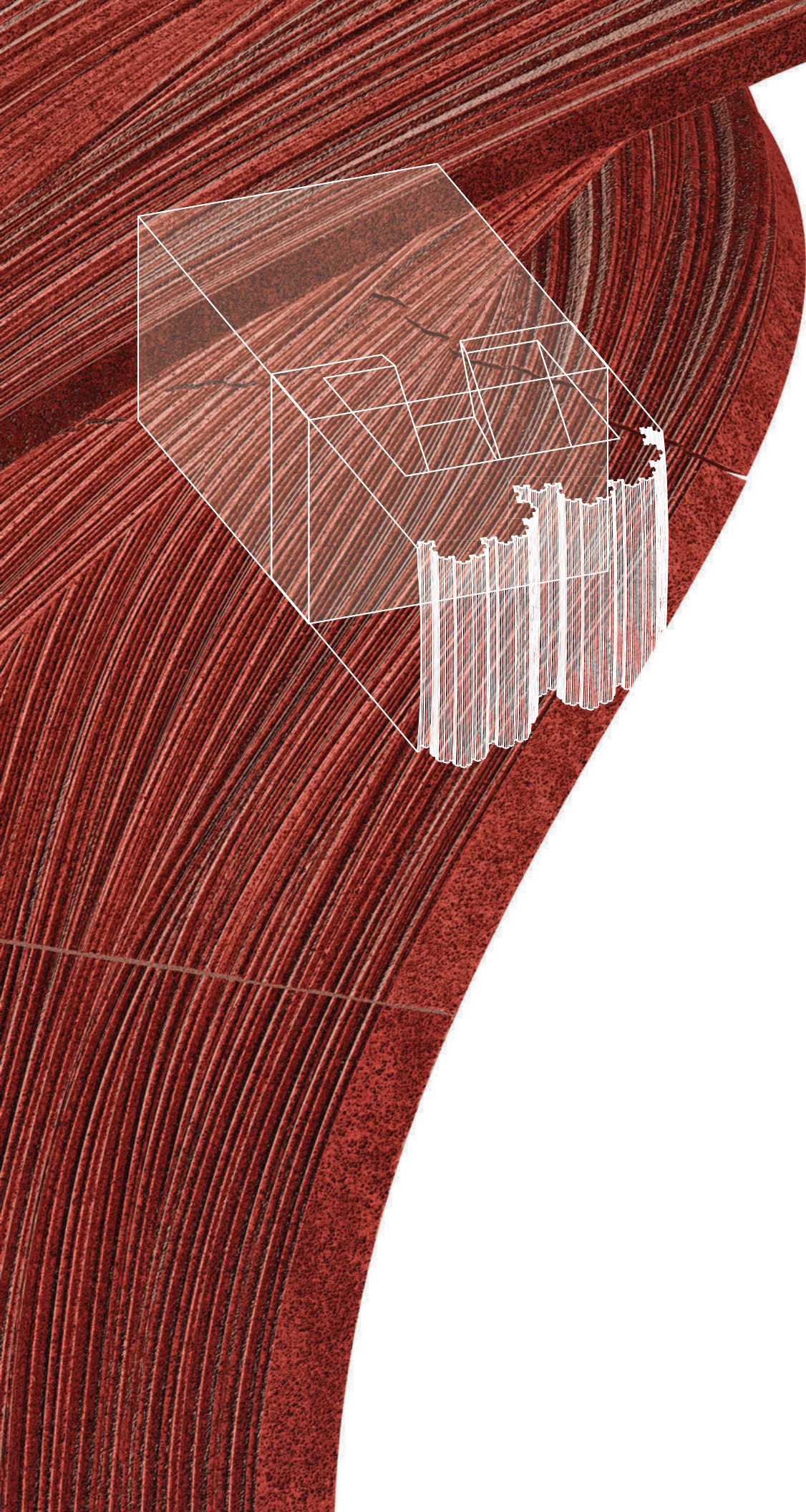



# RENDERS

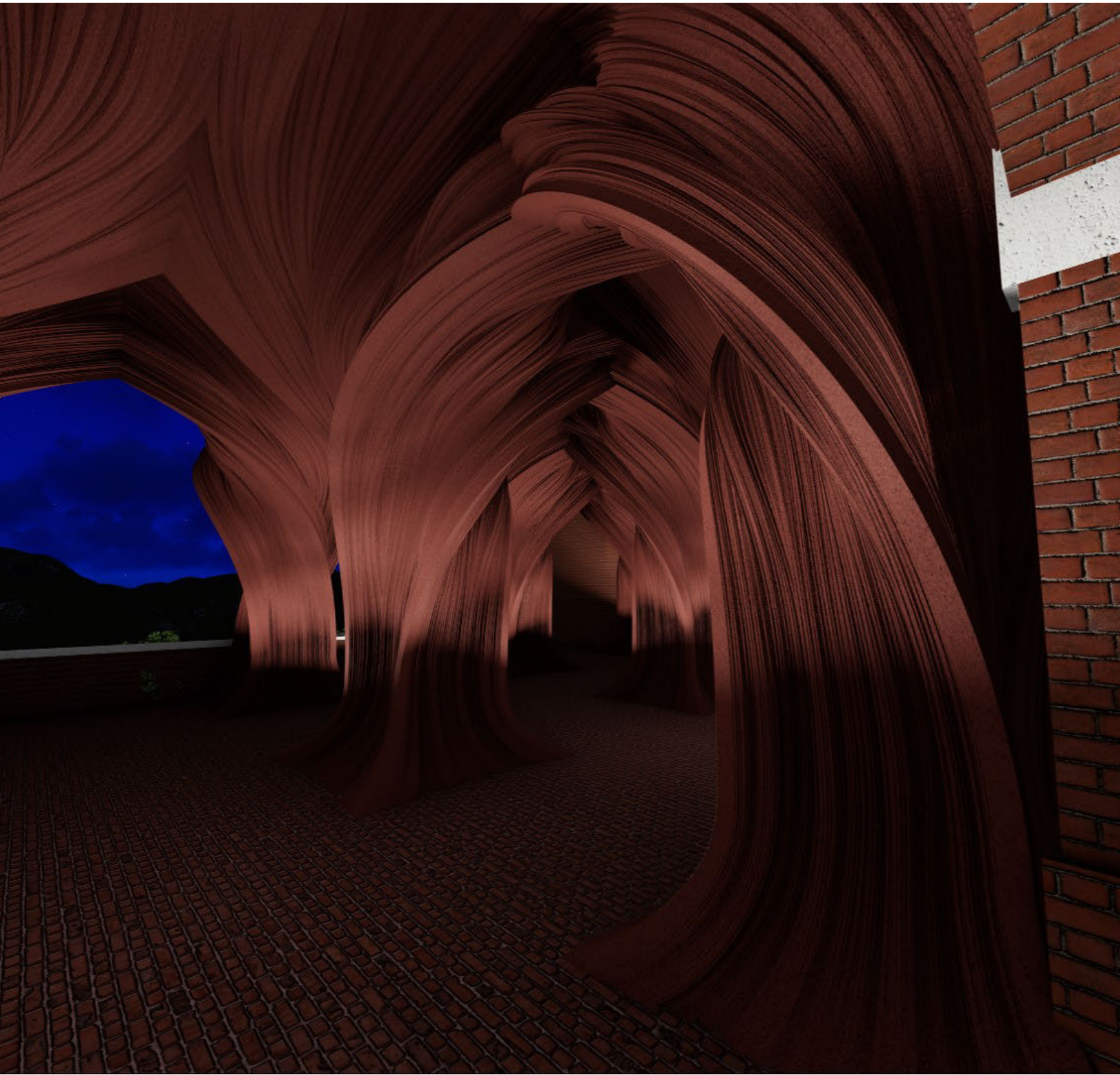

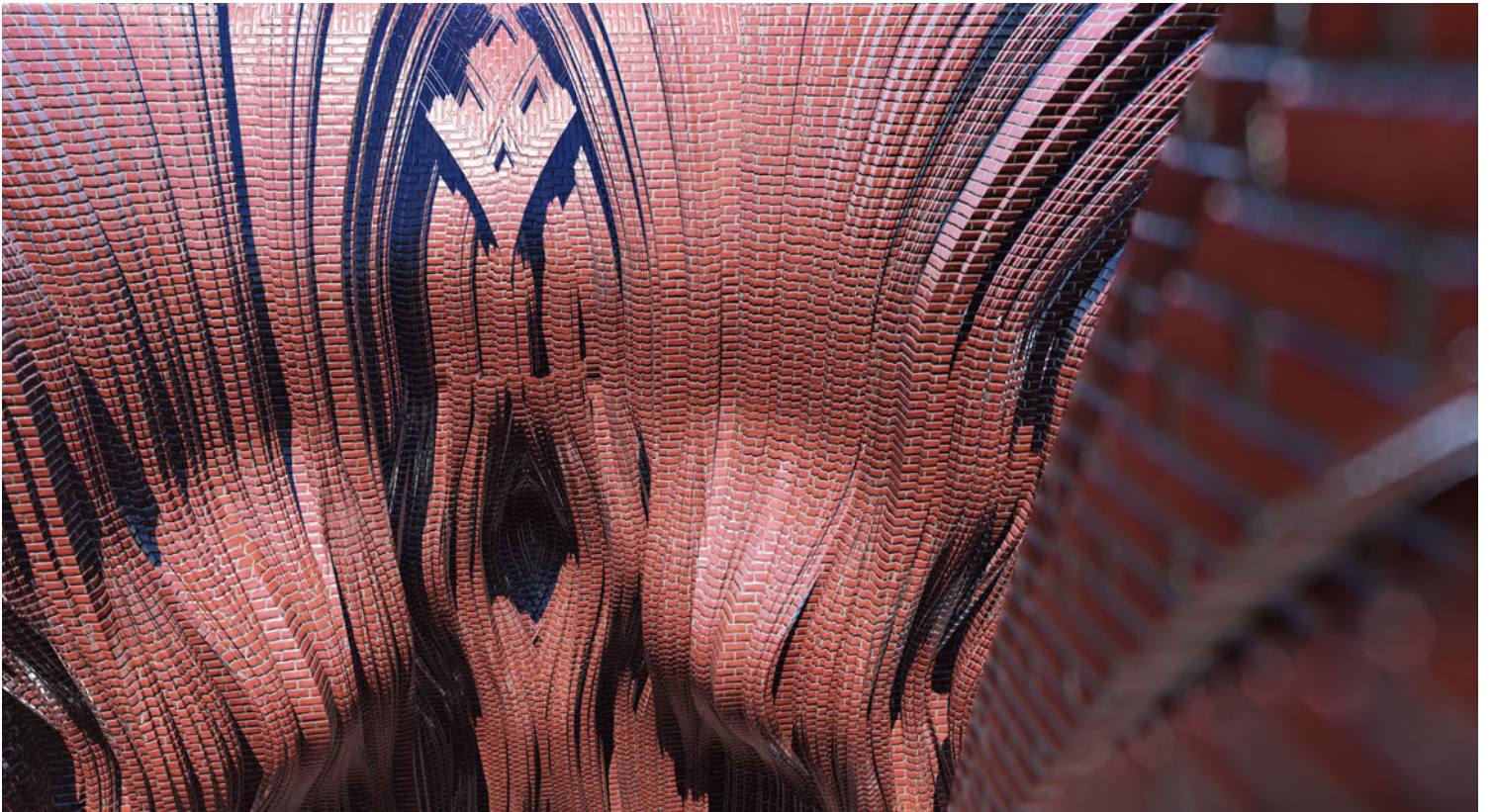
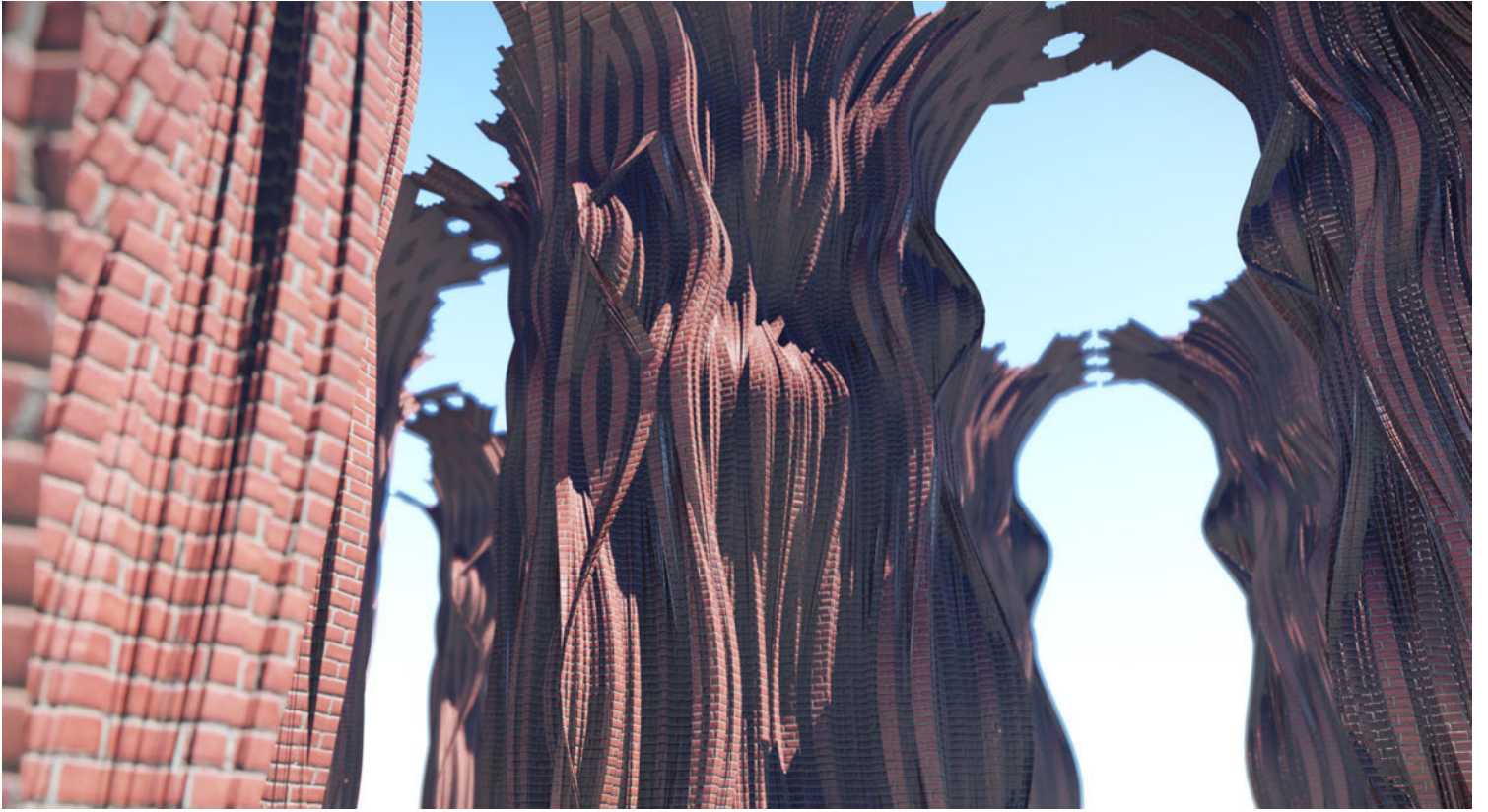

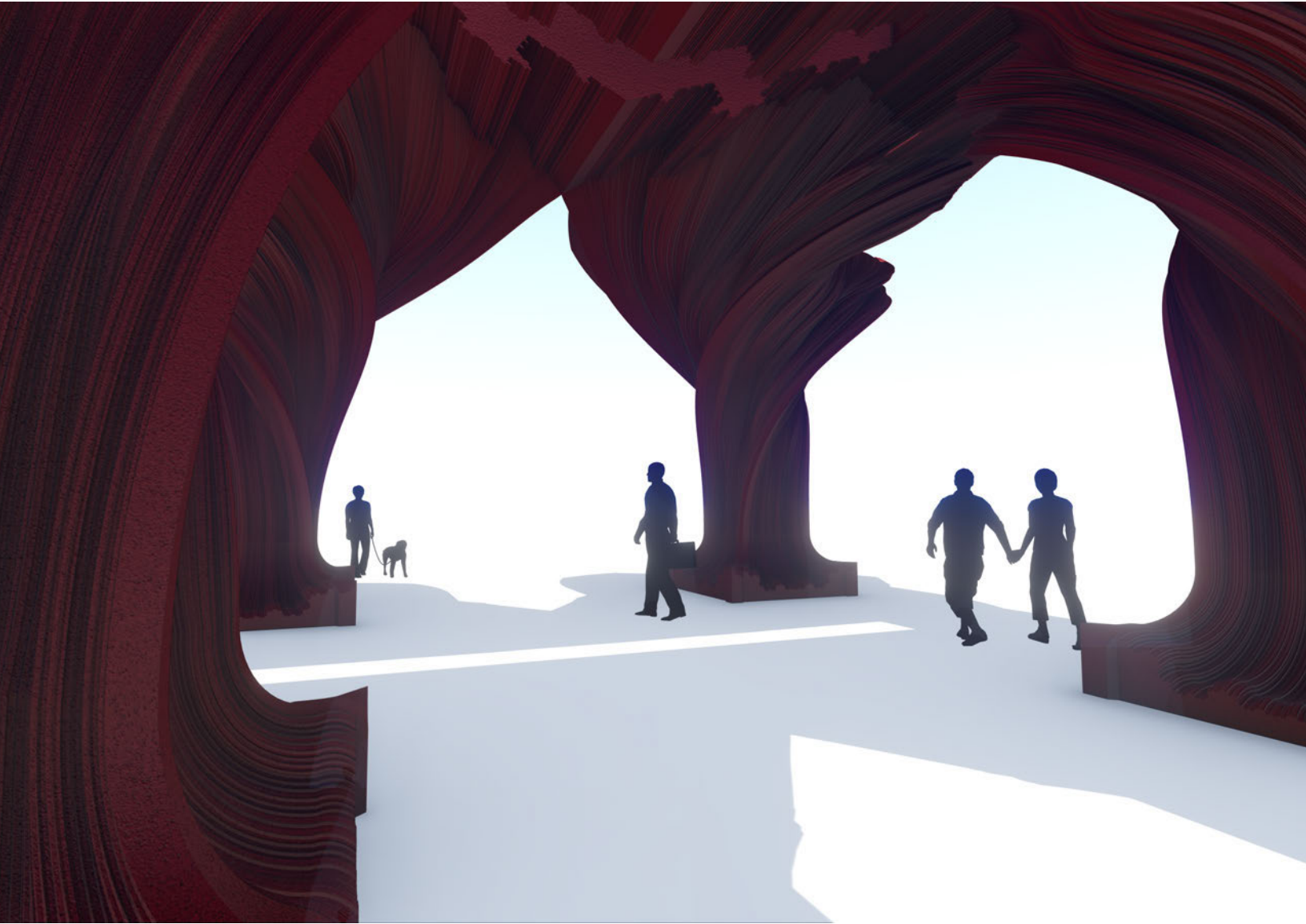

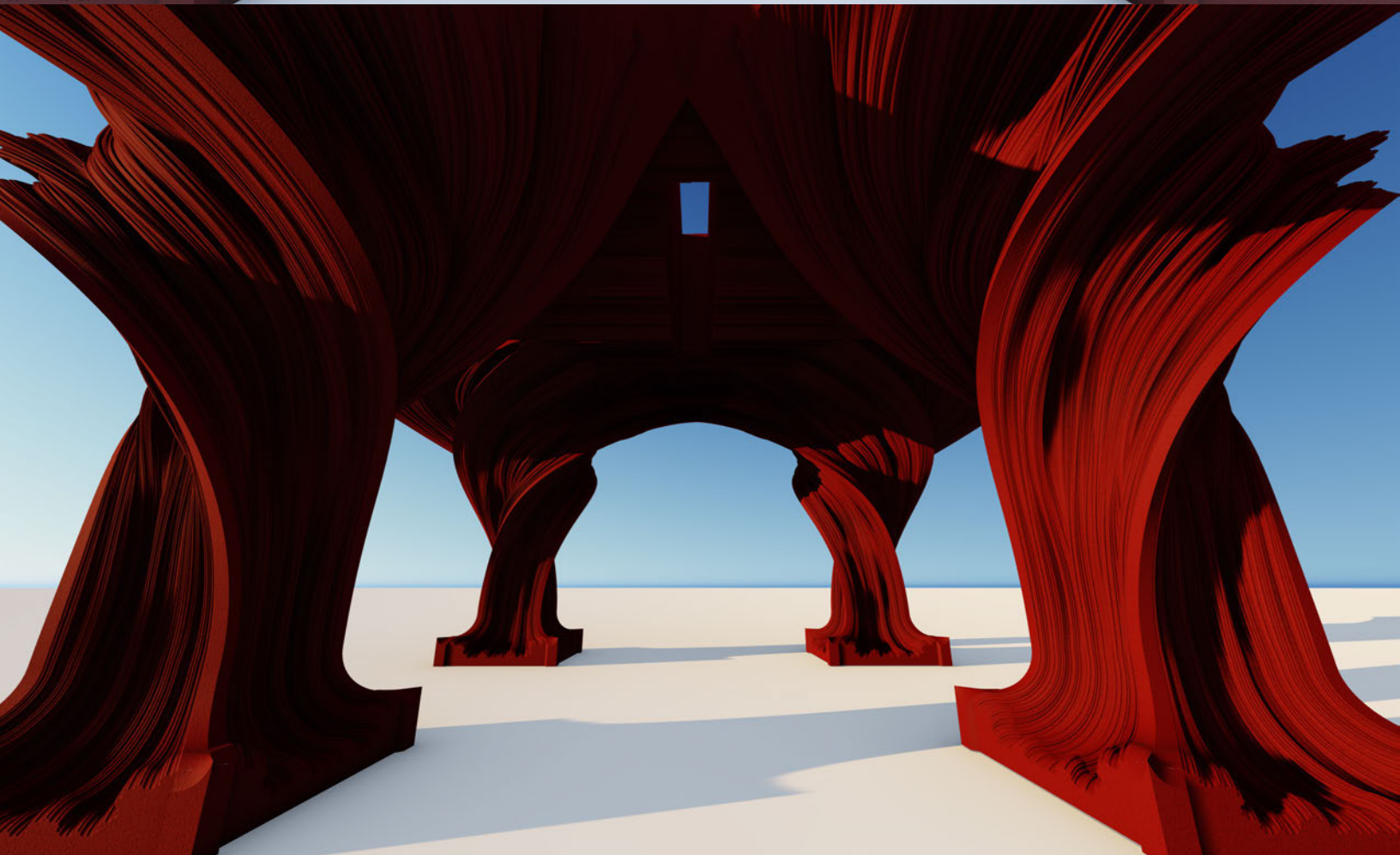
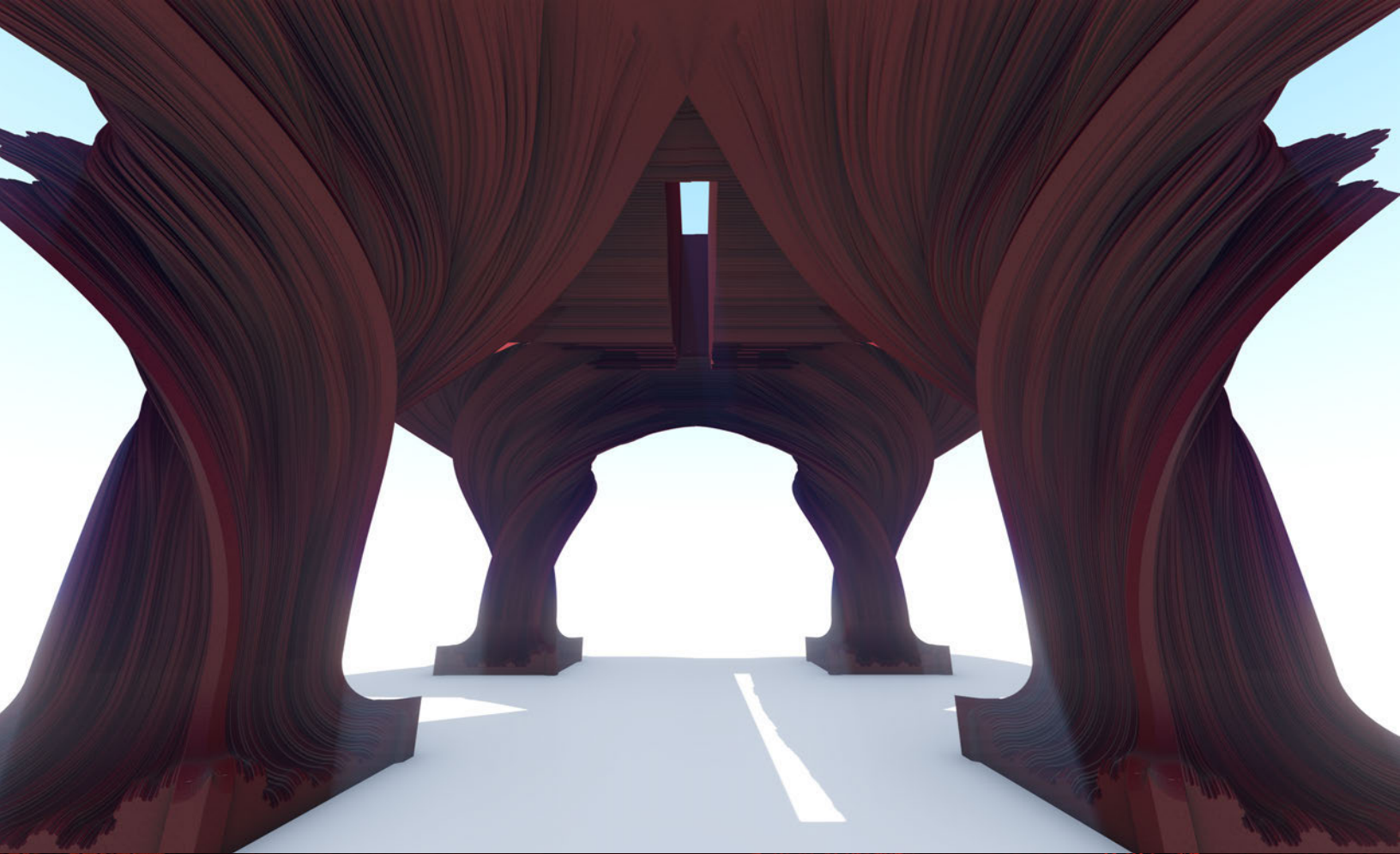

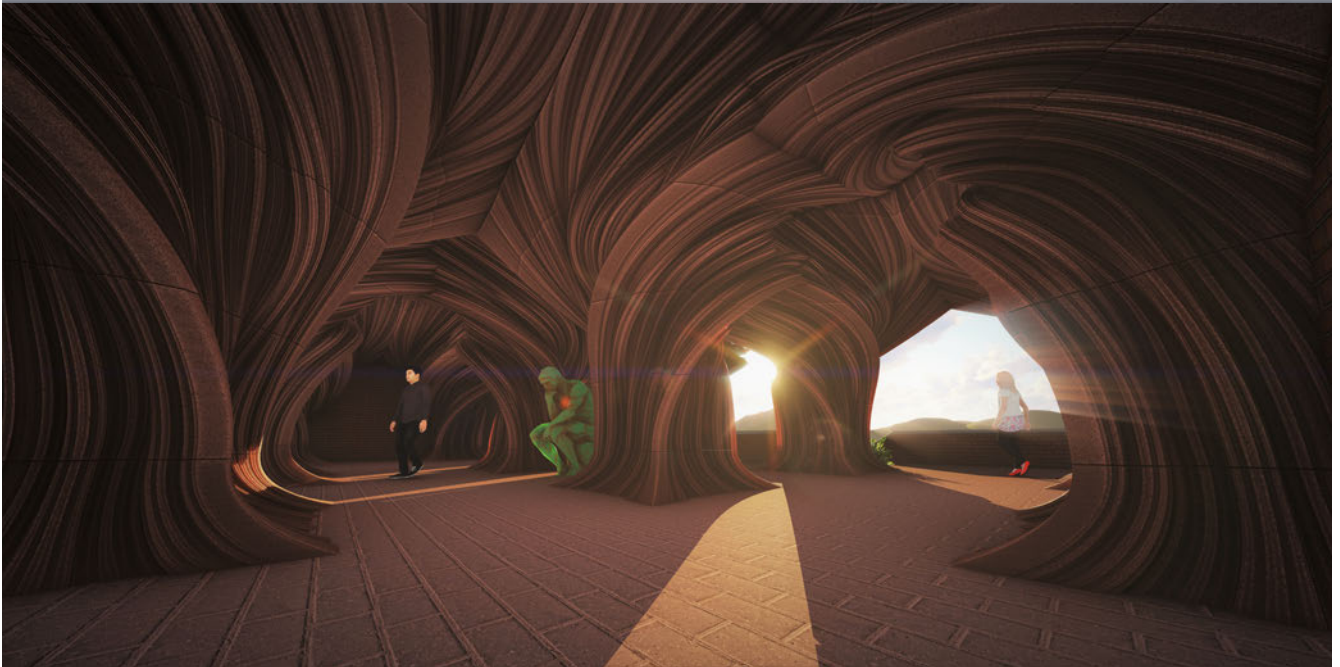





# BUSINESS DEVELOPMENT



# EXECUTIVE SUMMARY



## BLOCK METRIC FABRICATION

### Company Profile

3D Printed Architectural Applications for Historical replications and preservation

### Industry:

3D Printing Archi-  
tectural Elements

IIDD is a firm that wishes to peruse the potential of 3D printing ornamented designs with the use of shale/clay powder. This material compound can be molded by the tools of the architect into complex geometric shapes called "blocks." These can then be printed and fired allowing them to become the tectonic building bricks for a new way of building. Through the use of this material application to architectural historic preservation we aspire to serve the restoration community and bring beauty back to our built environment.

Founded: 07/2016

Location: Syracuse,  
NY

### Problem

High quality architectural ornamentation is lacking in our contemporary built environment due in part to:

Group Members: 4

- High cost associated with production of detailed elements
- High cost of materials used in creation of these architectural details
- High labor and time investment needed to produce these elements

Fundraising Seed

Vertical s

Architectural  
Preservation

The contemporary approaches to recreating historic architectural features as interior and exterior features are antiquated, relying on the technology of skilled craftsmen over laborious amounts of time to produce architectural objects.

Patents

### Solution

The use of 3D printing technology as a means in which to produce building materials is now a reality. This tool, which can create highly detailed and sculpted objects, can be used in pioneering new ways to create spaces with virtually an infinite amount of detail. By understanding the processes in which these designs can occur and the materials which will be used to fabricate those concepts we can develop spaces with hyper densification of detail; those at the forefront dealing with overall form and spatial composition and continuing down in scale until no longer visible to the human eye.

0 granted

0 pending

Executive Team

Founder: Jack

Phillips

Advisors

Linda Dickerson

Hartsock

Contact

### Target Markets

Historical Restorations/Preservation Architects.

Jack Phillips

Founder

jack.phil-

lips1517@g-

mail.com

(607) 244 - 3300

### Competitive Advantage

Our advantage over existing and future competitors is twofold. Not only are we able to produce exceptionally high quality products at an incredible cost advantage to our competitors but we are also able to meet their needs and bring our products to market much faster than conventional means of craftsmanship allow.

### Business Model

Company will provide 3D printing as services to the historic restoration architectural field so as to build a loyal clientele who will affirm the quality of the product.



# YEARLY FINANCIAL PLAN



**Our cost of production: \$0.003 per cubic square inch.**

**Competitors cost of production: \$0.07 per square inch**

If we compare the cost of manufacturing a 2' X 2' X 10" tall column capital that has 5,760 square inches of material, our method can achieve a profit of triple our production cost at a final price of \$50.00 for such a piece whereas our competitors would have to start at \$250 for these individual objects.

We are able to determine a 20% cost decrease per cubic inch of material produced for our cost to market as compared with our competitors.

Therefore, for every 373 cubic feet of material our competitors use, we are able to reduce our costs from theirs by almost \$40,000

- With an expected production rate of 343 cubic feet of material per month we can conservatively expect \$109,302 in sales within the first year.
- This would put us in the black with a net profit of \$8842 come the 2nd quarter of the second year in operation.

**Total cost associated with startup first year: \$ 155,500**

• Kiln Furnace: .....	\$3,500
• Material Processors: .....	\$4,300
• Jet Binding Additive Printer X 7 (3D Printer): .....	\$105,000
• Digital sculpting tools: .....	\$500
• Incorporation (attorney) fees: .....	\$10,000
• Research and Development: .....	\$10,000
• Salaries: .....	\$22,200/44,400

1 QUARTER OF COMPETITORS PRICE PER SQUARE INCH USED REVENUE STREAM  
Viability in 12 months

## First-Year Expenditures and Gains:

Expenses:	\$ 155,500
Revenue:	\$ 109,301
	<b>\$ 46,198</b>

1 Half OF COMPETITORS PRICE PER SQUARE INCH USED REVENUE STREAM  
Viability in 6 months

## First-Year Expenditures and Gains:

Expenses:	\$ 155,500
Revenue:	\$ 218,664
	<b>\$ 63,164</b>

## Second-Year Expenditures and Gains:

Expenses:	\$ 36,000
Revenue:	\$ 109,301
	<b>\$ 99,103</b>

## Second-Year Expenditures and Gains:

Expenses:	\$ 36,000
Revenue:	\$ 218,664
	<b>\$ 245,828</b>

## Third-Year Expenditures and Gains:

Expenses:	\$ 36,000
Revenue:	\$ 109,301
	<b>\$ 244,404</b>

## Third-Year Expenditures and Gains:

Expenses:	\$ 36,000
Revenue:	\$ 218,664
	<b>\$ 428,492</b>



---

## MISSION STATEMENT AND GOALS

The use of 3D printing technology as a means in which to produce building materials is now becoming a reality. This tool, which can create highly detailed and sculpted objects, can be used in pioneering new ways to create spaces with virtually an infinite amount of detail. By understanding the processes in which these designs can occur and the materials which will be used to fabricate those concepts we can develop spaces with hyper densification of detail; those at the forefront dealing with overall form and spatial composition and continuing down in scale until no longer visible to the human eye as well as recreating the esthetic qualities of culturally significant and historic architecture.

By producing these highly sculpted architectural elements at both a low cost and in a short amount of time we can bring this concept not only to into the built environment for architects but for a broader audience, for all those in the built environment. With the use of SHALE ROCK found throughout the upstate area we can substitute the more commonly used materials in powder printing and, through iteration, develop bricks with compressive strengths equal to that of industry standard load bearing bricks. 3D printing is used heavily for quick generation of prototype designs throughout the fields of architecture and engineering, as well as many other professions. With a multi-bed configuration it can be possible to mass produce objects quickly.

"Through the pursuit of beauty we shape the world as a home, and in doing so we both amplify our joys and find consolation for our sorrows." - Roger Scruton



---

IIID

---

A faded, golden-tinted image of a classical building facade with large columns and a pediment, serving as a background for the title.

**HISTORIC  
PRESERVATION**



A discussion on the use of 3D printing as a means to produce hyper customized and unique architectural elements for historic restoration projects, its effects on the current industry standards, and its impacts on the public perception of historic preservation.

*“The astounding growth that our resources have undergone in terms of their precision and adaptability will in the near future confront us with very radical changes indeed in the ancient industry of the beautiful... Neither matter nor space nor time is what it always was. We must be prepared for such profound changes to alter the entire technological aspects of the arts, influencing invention itself.” – Paul Valery, Pieces Sur L’Art. 1931*

## Content Overview

**Introduction to 3D Printing:** The method of production and its advantages to the preservation community.

**Current Industry:** Contemporary approaches to recreating historic architectural features as interior and exterior features

**President Studies:** Looking at in-field uses of 3D printing on existing buildings and the methods in which are deployed. Includes an interview with architect and Professor Michael Hansmeyer.  
The odyssey of the fabricated man;

**Craftsmen of the digital age:** Interview with Michael Hansmeyer on the topic of 3D printing.

**Projection:** implications of 3D printing within the field of historic preservation: Looking into the effects of how an emergent industry could change the field

## Introduction to 3D Printing: The method of production and its advantages to the preservation community.



The incredible application of 3d printing to the built environment cannot be understood if at first a brief explanation of the methodology isn't understood. The 3d printing industry has many diverging areas of work, however, the area in which we are primarily interested is within the binder jetting field. This additive method of 3d printing (as seen in diagram 1 ) takes powdered materials and transforms them into objects. These objects, typically made from a starch or gypsum derivative, have typically always been extremely brittle and delicate. Normally they would be dipped into a resin or glue so they would be allowed to cure and harden. However, in the process which I wish to employ the material, consisting of a clay base, can be extracted from the printer and then fired in a kiln, making it an extremely durable and structural application to a building.

This process can allow for the creation of objects of any geometry and detail level, acquitting itself from the use of any molding or supporting structure during the construction of the objects. These factors and others combine to give time and cost benefit to employing 3d printing for the creation of architectural elements.

**Current Industry:** Contemporary approaches to recreating historic architectural features as interior and exterior features

In the field of architectural preservation the current practice to replicate items and design details of buildings involve many of the same techniques that had been used to create the original pieces. For instance, if a column capital system on the exterior of a building needs to be replaced due to damage the conventional way in which to replace the system would be to hire a master carpenter who could either carve out of wood, clay, stone, or any number of composite materials or to make a negative of the object so as to cast a liquid into it and form a mold. This method, along with being extremely time consuming, is tremendously expensive. Having to carve out by hand the objects desired is a reproduction of the techniques used in the original process of production, which essentially involves the same technology level as when those pieces were first produced.

In regards to the production of brick, which this thesis wishes to address directly, standard industry methods of production are extremely efficient and need not at this time be improved.

There are predominantly six steps that govern the brick making process.

**Step 1:** The unrefined material is brought in and pulverized into a consistent powder. **Step 2:** The Refined powder is then mixed to create a stiff slurry that which is pliable and can be molded into shape. **Step 3:** The now wet mixture is extruded





through a die to form bricks. Step 4: The rectangular block then has a custom surface added to it. Step 5: The block is then split into individual bricks. Step 6: The bricks are then fired so as to complete the process of brick production. By understanding the fabrication methods for standard industrial brick making and juxtaposing that with the craftsman based method for creating architectural elements it becomes apparent that the two are seemingly incompatible with one another. Here we have reached the intersection of our age, the technological bloom that can allow us to transgress these two worlds, that of manufacturing and craftsmanship, and unite them into the spectacular, the continuation of that great tradition which we have been given by our ancestors, that of the creation and preservation of beauty.

### Precedent Studies: Looking at in-field uses of 3D printing on existing buildings and the methods in which are deployed.

By producing highly sculpted architectural elements at both a low cost and in a short amount of time we can begin to bring the concept of 3d printing not only into the built environment for architects but also for a broader audience, for all those in the built environment. With the use of shale rock found throughout the upstate area of New York it is possible to substitute the more commonly used materials in powder printing and, through iteration, develop bricks with compressive strengths equal to that of industry standard load bearing bricks. 3D printing is used heavily for quick generation of prototype designs throughout the fields of architecture and engineering, as well as many other professions. With a multi-bed configuration it can be possible to mass produce objects quickly.

For example: take the geometric complexity of an iconic capital. This drawing can be traced, extruded and made into a 3 dimensional digital object. If we take the information from this diagram and construct that digital model we can fabricate from that model an infinite amount of iterations of a 3d printed object. This, traditionally done with a gypsum or starch material now being produced with clay and shale allows for the objects to be structural, ornamental, and durable.

These traditional shapes, pertinent to the historical preservation world, are easy enough to produce. This model, having taken me only around five hours to produce digitally, can then be used as a template for later iterations on the same form. For instance, if a particular column capital needed to be scaled up or widened it would only be as difficult as typing a few commands into a computer and then replicating that form for a client. The ease with which this allows the digital craftsmen to control their art is significant,



and their digitally sculpted pieces will dramatically cut down on the production time necessary to yield these objects.

Looking towards built examples of 3d printed spaces and the capabilities with which it can achieve we will have to leave the realm of architectural preservation for just a brief moment and examine the work of Michael Hansmeyer, a pioneer in the field of 3d printed space making. The work of Michael Hansmeyer emphasizes the desire to free ourselves from reference forms. “What is the origin of the forms that we design, what kind of forms could we design if we wouldn’t work with references anymore.” He discusses the idea of freeing our self from our experience. This idea he proceeds to accomplish by creating designs that are encoded as an algorithm; that is to be devoid of experience. Mario Carpo, the architectural historian and critic, points out it was Vitruvius who didn’t provide any drawings, but simply provided a list of steps, essentially an algorithm, for the craftsmen to perform. “I didn’t design the form, I designed the process that generated the form.” This, the ethos of a man who is revolutionizing 3d printing.

By understanding the processes in which these designs can occur and the materials which will be used to fabricate those concepts we can develop spaces with a hyper densification of detail; those at the forefront dealing with overall form and spatial composition and continuing down in scale until no longer visible to the human eye.

These examples go to prove the dexterity with which 3d printing achieves, and that fact should be understood before it is used in any project, historic or otherwise. And while, perhaps, the work of Michael Hansmeyer exemplifies the new attitude towards the technology of 3d printing as it relates to new forms and geometries, nonetheless, it shows us lessons through which we can employ this technology with an attention to detail to the crafted environment.

### [The odyssey of the fabricated man; Craftsmen of the digital age. Michael Hansmeyer Interview October 15th, 2016 by Jack Phillips](#)

“You walk into this room at your own risk, because it leads to the future, not a future that will be but one that might be.” As that room appeared on my computer screen through the medium of a technology that had only served to shrink the world the voice of Rod Serling echoed through my head. Before me was that man, six hours and one ocean ahead of me, who had walked through the door into a room; a room that I suspected my presence made smaller.

After our pleasantries were exchanged I set forth to ask questions, not of the technicalities, but of his art and ethos.

His reply, a question as to the qualities of my character. “What are



the origins of the forms we design?” This interrogation, narrated by a man whose work may be that small point in time where new forms of beauty emerge had a profound impact. . Our back and forth, productive and enlightening, served to situate both of us in the understanding that the common goal of beauty through the medium of 3D printed objects was a meaningful pursuit.

“How is it that you can control such beautiful forms when so much detail is applied to the surfaces of your tectonic objects?” I asked with all the humility of an apprentice mindful he must someday out-craft his master. But I would find out that it was within the medium itself where these objects were crafted that had also spawned their genesis.

“The shape of the objects with which I start is very simple. It isn’t until I add the algorithms, the lines of coding that form infinitely complex shapes that the two become one.”

“When you use this code do you find that you are in control of the objects being created or, instead, do you feel that you are more like a digital archeologist; discovering new forms of beauty in the old shapes of historic references?” His reply was to indicate that he would exercise just enough control over his designs to still remain the adventurer and be able to find new and meaningful architecture in the generated constructs.

“Folding surfaces are the product of my programming. By adding more and more depth in the amount of folding that occurs we can develop highly intricate designs using the 3D printer and this formula.”

“So this process is what derives the finalized product?” I asked in a way which would indicate my well-intentioned presumption. “How, then, do you begin to bring these forms from the dimension of the digital to that of reality.”

Knowing the manner in which he had produced his earlier work, experimenting in several methods of production, I wanted to acquire a glance into where Michael Hansmeyer saw our shared discipline going. His answer was a confirmation to the same question I had asked myself one year ago. Receiving an answer with joint commonality gave a unifying quality to our shared discipline. Perhaps this room I’ve found myself in, a room with others already inside, isn’t one of adversaries, but is a space interwoven with the hopes of like-minded people; men and women in search for the answers which have not yet been asked.

When talking with professor Hansmeyer about the work he has accomplished it was interesting to note in which ways he has pivoted. Being that he works much more for the passion of the ends than of means he has given himself more liberty in marketing his product to those seeking unique insulations such as his Arabesque Wall pictured below. However, while in discussion it was interesting



to note that he has done several rehabilitation projects involving the 3D print of formwork which was then cast in iron. This use of the printing technology to replicate at low cost very high detailed portions of buildings I found deeply intriguing. “Mr. Hansmeyer, you’ve developed programs, codes, and manufacturing processes in which to create new forms of architecture. What thoughts do you have on focusing more perhaps on the rapid development of pre-existing architectural forms as a means in which to slowly bring the industry and culture to where you have developed this ideal of it?”

His response was that overwhelming disappointment felt when you can see a clear glimpse into the possibly for future development while the other is unable to see the forest for the trees. He made clear that he wished to explore the continual possibilities of the special tectonics of his designs and computer programs. Understanding that his motives are very different from mine, even so I could not help but feel challenged to produce that which the Professor Hansmeyer and I both strive for. That idea of beauty produced in a way which makes widely available the beauty which we feel should be enjoyed by everyone.

### Projected implications of 3D printing within the field of historic preservation: Looking into the effects of how an emergent industry could change the field

The use of 3D printing technology as a means in which to produce building materials is now becoming a reality. This tool, which can create highly detailed and sculpted objects can be used in pioneering new ways to create the architectural details once crafted by sculptor and artisans. This technology, combined with materials readily available and inexpensive to the consumer, is sure to have an impact on not only the quality of architectural objects produced, but also the entire historical preservation community as a whole. The idea of expensive and time consuming projects necessary to restore buildings will no longer exist. The public perception towards the field of preservation has the potential to shift rapidly, from one of obstinate servitude at its worst to one of expedient conventionalism that will, with a little luck, encourage the average citizen to take a vested interest in the preservation and overall beautification of their lived habitat.



✦ NON NOBIS DOMINE NON NOBIS ✦  
✦ SED NOMINI TVO DA GLORIAM ✦



---

---

# IIID

---

---

A background image of a classical building facade with large columns and a pediment, overlaid with a semi-transparent orange filter.

# CONTACT INFORMATION

**JACK PHILLIPS**

**FOUNDER and CEO**

PHONE NUMBER: (607) 244 3300

[jack.phillips1517@gmail.com](mailto:jack.phillips1517@gmail.com)

1941 ST HWY, BAINBRIDGE, NY 13733



# CONCLUSION

# CONCLUSION

The potential pavilion designs iterated in this thesis express a desire to carry out this method of construction and assembly in an applied way. This design thesis found great success with iterations on joint types and connection moments within brick structures abetted by the use of 3D printing.

This thesis has strived to be as pragmatic as it was conceptual. To that end this thesis was applied to the historic restoration industry, with all its uses in manufacturing as well as stereometric joint fabrication. In concordance with standard business development, a team of myself and other closely knit individuals have developed a business plan which we are in the process of putting into action. Placing first in a college, and later, state wide competitions we now have over \$15,000 with which we will further this thesis's original intention; creating stereometric designs which can interlock to form whole monolithic blocks to create complex spacial volumes.

Furthermore, this thesis has proven itself to not be stagnant, that is to say, one that will not be committed entirely to paper. As we now begin producing historic elements for our first clients we are pleased with the knowledge that in the very near future it is possible that we will not only print, but construct these pavilion spaces as full scale brick volumes.



## Citations



- Hansmeyer, Michael “Inhotim Installation.” Computational Architecture, <http://www.michael-hansmeyer.com/projects/inhotim.html?screenSize=1&color=1#6>
- Hansmeyer, Michael. “Märchenwald - Venice Biennale 2016.” Computational Architecture, <http://www.michael-hansmeyer.com/projects/maerchenwald.html?screenSize=1&color=1>
- Hansmeyer, Michael “Arabesque Wall.” Computational Architecture, [http://www.michael-hansmeyer.com/projects/arabesque\\_wall.html?screenSize=1&color=1#2](http://www.michael-hansmeyer.com/projects/arabesque_wall.html?screenSize=1&color=1#2)
- Wout, Indianen. “Unfold, Stratigraphic Porcelain.” Unfold, <http://unfold.be/pages/stratigraphic-porcelain>
- Hansmeyer, Michael. Dillenburge, Benhamin. “Digital Grotesque: A 3D printed room by Michael Hansmeyer.”
- Designboom, <http://www.designboom.com/architecture/digital-grotesque-a-3d-printed-room-by-michael-hansmeyer/>
- Johnston, Lucy. Digital Handmade. Thames and Hudson, 2015
- Arvo Pärt. “Stabat Mater.” Vocal and String Trios, 1985
- Linder, Karen. “Tethon 3D, Ceramic 3D Printing.” Printing, <http://tethon3d.com/ceramic-3d-printing/educational-links/>
- Schools.CBE. “Sedimentary Rocks.” <http://schools.cbe.ab.ca/b379/students/Grade3/RocksAndMinerals/sedimentary.html>
- Veri, Cathy. “Old Brick Originals: Tumbled Thin Brick by General Shale.” AMP Brick and Stone <http://www.amp-brick.com/old-brick-originals-tumbled-brick-by-general-shale/#prettyPhoto>
- Pinewood Farms. “French Red Clay Powder (Frontier).” [https://www.pinewoodfarms.com/store/p43/French\\_Red\\_Clay\\_Powder\\_%28Frontier%29.html](https://www.pinewoodfarms.com/store/p43/French_Red_Clay_Powder_%28Frontier%29.html)
- Haas, Yvo. “PLAN B.” Focus. <http://ytec3d.com/focus/>
- Friedman, Jared. Working Matter: Optimizing Material Distribution for Thermal Performance. Harvard University Graduate School of Design Thesis
- Bechthold, Martin. Kane, Anthony. King, Nathan. Ceramic Material Systems: In architecture and interior design. Bitkhauser Basel. 2015
- Le Mehaute, Alain. Translation by Dr. Howlett, Jack. Fractal Geometries: Theory and Applications. CRC Press Inc. 1990
- Stevens. Roger T. Understanding Self-Similar Fractals: A Graphic Guide to the curves of Nature. R&D Technical Books 1995

### Special Thanks to:

Jonathan Livingston, Head of research and development at General Shale

Michael Hansmeyer, Computational Architect and VC for the Academy of Fine Arts in Vienna

Dr. Shobha Bhatia, Department of Civil and Environmental Engineering, Syracuse University