

Fall 2016

Provisional Permanence

Ian M. Jackson

Matthew J. Marinelli

Follow this and additional works at: https://surface.syr.edu/architecture_tpreps



Part of the [Architecture Commons](#)

Recommended Citation

Jackson, Ian M. and Marinelli, Matthew J., "Provisional Permanence" (2016). *Architecture Thesis Prep*. 332.
https://surface.syr.edu/architecture_tpreps/332

This Thesis Prep is brought to you for free and open access by the School of Architecture Dissertations and Theses at SURFACE. It has been accepted for inclusion in Architecture Thesis Prep by an authorized administrator of SURFACE. For more information, please contact surface@syr.edu.



PROVISIONAL PERMANENCE

Ian M. Jackson & Matthew J. Marinelli
Primary Advisor Prof. Stenson



BEACH + LIFE

- *A shoreline covered by sand, gravel, or larger rock fragments.*
- *A way or manner of living.*

CONTENTION

The oceans take up 71 percent of our planet. For the east coast, Barrier Islands are the first line of defense against storms and will become the most affected areas because of sea level rise in the next hundred years. There is no stopping sea level rise and the time and money spent thus far has not been efficient and requires a different approach.

The barrier islands may be the first line of defense against storms, but they are more than that. There is a long standing allure to the islands that we've come to know as beach culture. For most families, it's a tradition during the summer to travel east or west and experience their favorite beaches, bars, and boardwalks.

In the next decade this island could be devastated and without proper design intelligence the island might not reshape itself.

Our approach to this project may seem fatalistic, but in an effort to preserve the beach culture that we've both grown up with we cannot stick our heads in the sand and wait for the inevitability of sea level rise. We believe it is possible to preserve this vital part of regional culture through an architecture and landscape strategy that incorporates barges and boardwalks in an effort to mitigate the potential damages brought on by storm surges and sea level rise through site density and framework.

TABLE OF CONTENTS

SECTION 1.0

- Barrier Islands History (1.1)
- Long Beach Island Demographics (1.2)

SECTION 2.0

- Storm Information (2.1)
- Hurricane Paths (2.2)
- Island Vulnerability (2.3)
- Past Damages (2.4)
- Island Scenarios (2.5)
- Rising Waters (2.6)

SECTION 3.0

- FEMA Guidelines (3.1)
- Insurance (3.2)

SECTION 4.0

- Site Mapping (4.1)

SECTION 5.0

- Barges (5.1)
- Barge Division (5.2)

SECTION 6.0

- Making a Datum (6.1)
- Site Strategies (6.2)

SECTION 7.0

- Precedents (7.1)

SECTION 8.0

- Sources (8.1)

PROVISIONAL

+

PERMANENCE

-----○ *Arranged or existing for the present,
possibly to be changed later.*

-----○ *The state or quality of lasting or
remaining unchanged indefinitely.*



BARRIER ISLANDS 1.1

NATURAL LANDFORMS

Barrier islands are landforms that are created out of sand by the currents and tides of our planet's oceans. These elongated beaches provide a protective boundary that diffuses the powerful energy from waves before reaching the main coastline and adjacent wetlands. As global warming and sea level rise continues to develop on our planet the barrier islands along the eastern coastline become increasingly more vital as a safe guard.



ECONOMIC BOOM

Beginning in the early 20th century, the New Jersey Barrier islands went through a large economic boom of construction and living. Outcroppings of hotels and establishments popped up everywhere, creating an escape from the hustle and bustle of the city life. These barrier islands attained the form of the New Jersey beach lifestyle hub. Which is what we have come to know as beach culture.



LONG BEACH ISLAND

Centuries before LBI was an ideal beach destination the island was a hunter's paradise where people could hunt, fish, and trap. It became the ideal location for many wealthy outdoors-men from Southern New Jersey and Philadelphia. Any forms on the island began as makeshift shacks on the coastal front. The island was remote to the point where the only point of get there was by boat from Manahawkin. These days the island is much more developed with many vacationers arriving by car load over the singular bridge leading into Ship Bottom. Long Beach Island really began to see changes around the 1960s as development of the islands continued to change the once wild island into one of New Jersey's favored destinations. However, at the same time development also sets into place a sense of upscale living and design which has altered the original feel of the island for most locals.

LBI DEMOGRAPHIC 1.1

POPULATION

The island is home to around 7,000 year long residents and during the summer season the population rises to between 100,000 to 150,000 each year. Many families and individuals travel down from Pennsylvania, New York, and Delaware to partake of the vivid beach culture there.

REAL ESTATE

Many people homes on the island and the location of those homes will create a varied housing value depending on whether they are looking to purchase or merely rent for a couple weeks. There many different types of houses and condos available on the island. Long Beach Island has something for everybody.

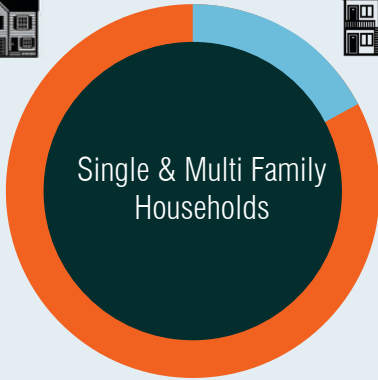
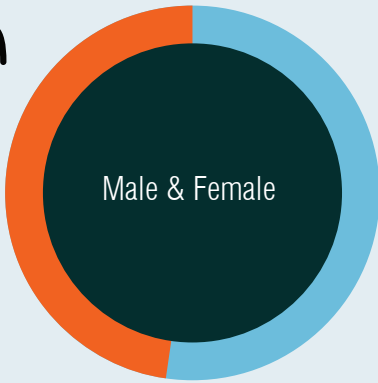

POPULATION TOTALS

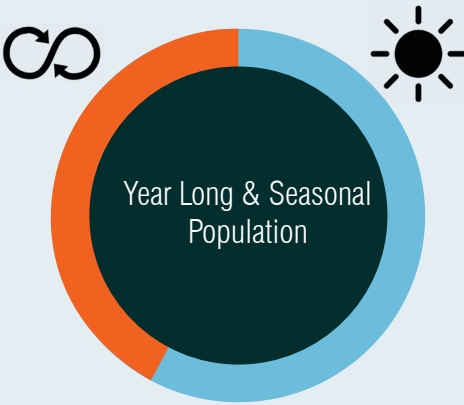

TOTAL HOUSEHOLDS

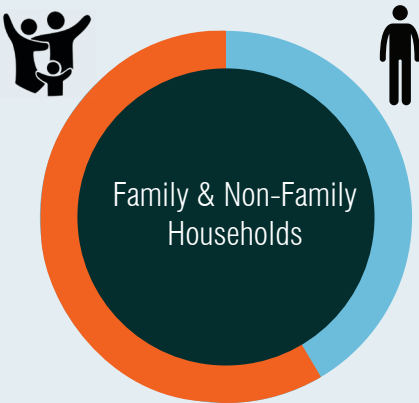

HOUSING TYPE

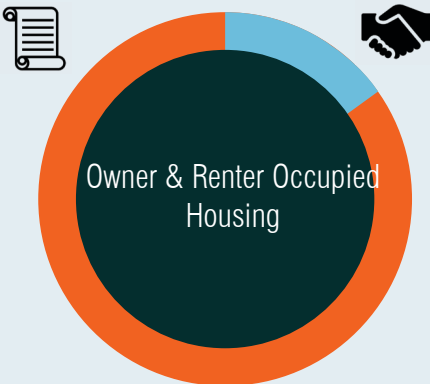

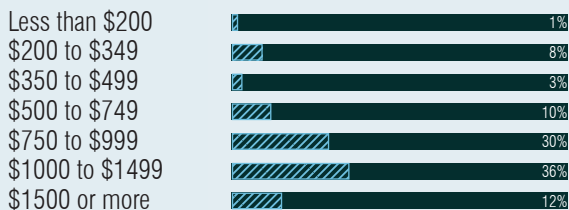
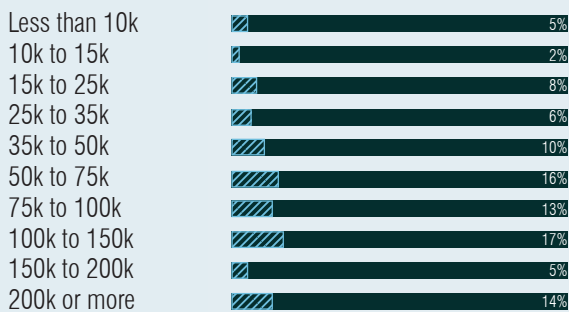

HOUSING VALUE

The housing value on Long Beach Island has a varied range of values. The northern and southern ends of the island vary in both price and size of property. On the northern end of the island houses range between \$800,000 and above. In contrast the southern end ranges more between \$500,000 and \$800,000.

AVERAGE INCOME

Between the price of real estate and the average income of some residents some people cannot afford to pay the \$250,000 minimum coverage of flood insurance regardless of whether houses follow the proper premium guidelines in construction and design.

RENTING RATES

Depending on which end of the island you are renting on, the price vary also. Relating to house value, the northern end of the island generally costs more to rent than the southern end.

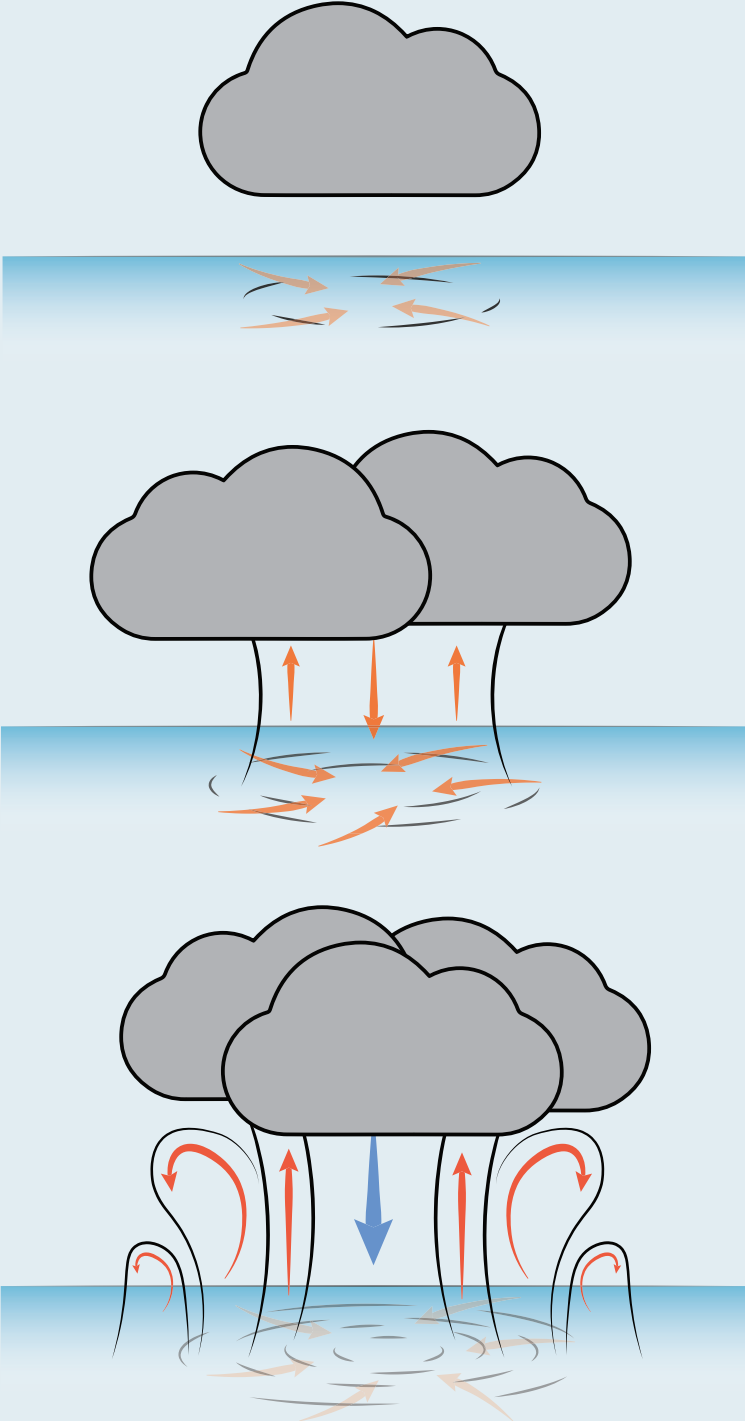

STORM GLOSSARY 2.1

TROPICAL DEPRESSION

Referred to also as a “tropical low” is a disruption in normal weather patterns with evident surface circulation. This also includes maximum sustained winds of less than 34 knots not near the center.

TROPICAL STORM

An organized arrangement of powerful thunderstorms with a defined surface circulation and maximum sustained winds between 34 and 64 knots. This level of storm begins to have a cyclone shape.

HURRICANE

A tropical cyclone is a system with sustained winds of at least 66 knots (estimated up to 185 knots). These systems develop an eye. Surrounding the eye is the eye wall which is a large area of strong thunderstorms.

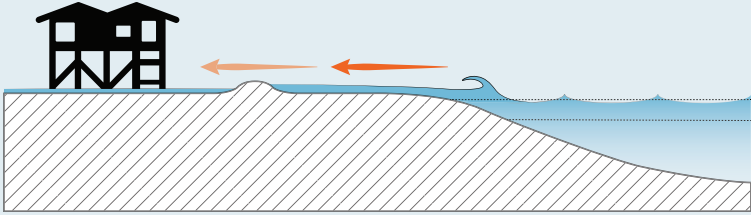
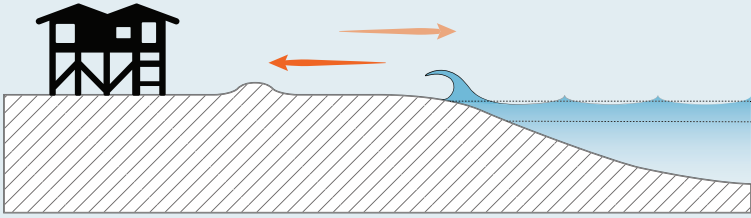

STORM SURGE

Is an abnormal rise of water generated by a storm, which relates to the five processes. This rise is over and above the predicted astronomical tide.

WAVES (RUN UP/ SETUP)

Waves can be broken down into two categories depending on how they break onshore. Run up is when waves break on the shore and water is pushed onto the beach. Setup is when waves continue to break on the beach and the water does not recede.

FRESH WATER INPUT

Rain prior and during a hurricane can cause river levels to rise and flow down towards the coast creating a rise in bay and delta water levels. Also rain from the pre-storm clouds

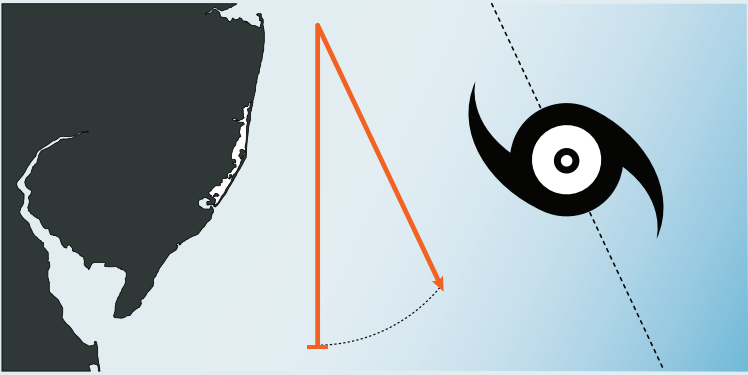
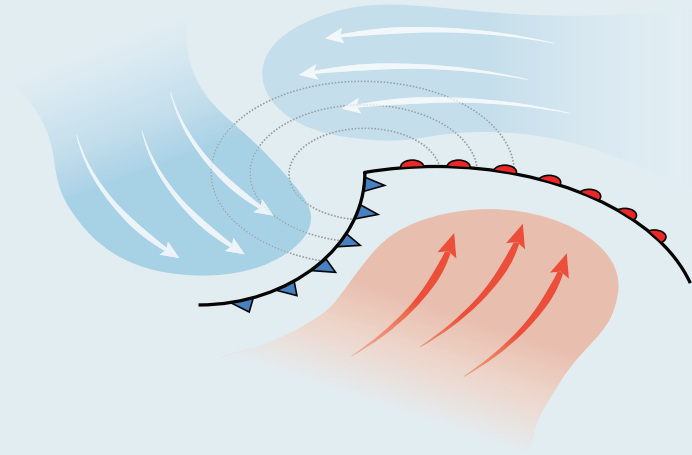

LOW PRESSURE

Lower pressure areas or depression is when the atmosphere pressure changes, causing the cycle of atmospheric lift. This leads to cloudy skies and thunderstorms.

ANGLE TO COAST

The angle at which a storm approaches a coastline can affect surge levels. When a storm moves onshore perpendicular to the coast it has a greater chance to produce a higher storm surge than a storm that moves parallel to the coast or moves inland at an oblique angle.

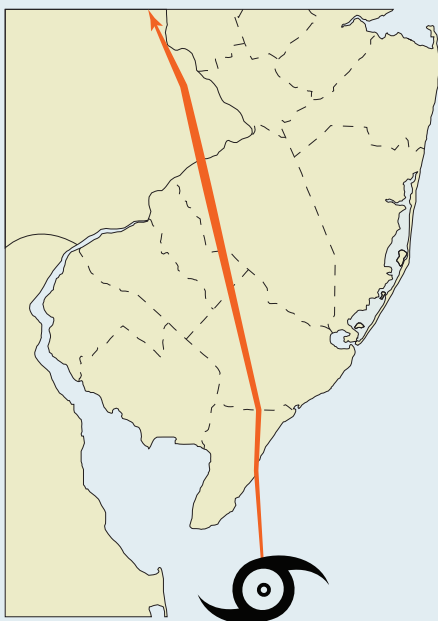

HURRICANE PATHS 2.2

THE GREAT HURRICANE | 1903

Known to be between a category 3 and 4 on the scale. The storm caused major damage to the old railroad in Brigantine and each town up the coast from Cape May to Asbury Park received similar significant damage. It took nearly a decade to restore the shoreline to its former shape.

ATLANTIC HURRICANE | 1944

It did not touch down in NJ but the winds from the storm caused strong storm surges which destroyed houses in the Harvey Cedars area of Long Beach Island. The storm also caused a drop in beach tourism due to the occurrence of multiple storms within that year. There were two other storms to happen around the same time as this storm.



HURRICANE DONNA | 1960

One of the only storms in early history to successfully assault every East coast state in its path as a category 2 hurricane. The storm caused intense tidal flooding from storm surges.

HURRICANE FLOYD | 1999

One of few storms to physically touch down on the coast and sweep the entirety of the shoreline. Many residents were left without power for a prolonged time and the reported storm surges had a height of around 3 feet.

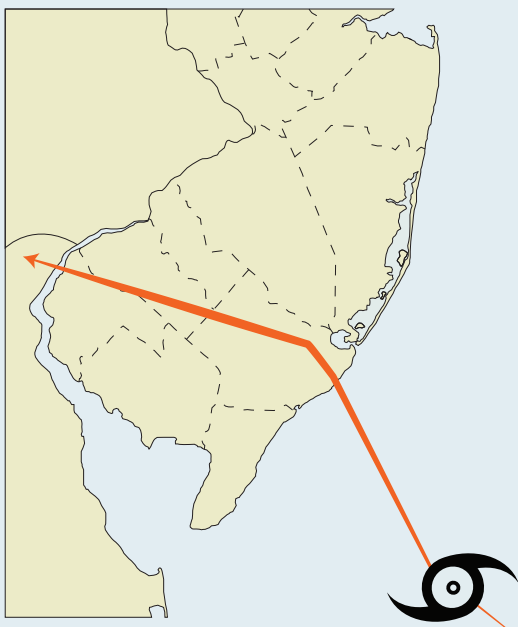

HURRICANE IRENE | 2011

One of the worst storms in terms of flood damage. Many transportation services and causeways were shutdown due to severe flooding compared to the high winds of Hurricane Sandy. Declared by the governor to be a state of emergency; many coastal cities were evacuated.

HURRICANE SANDY | 2012

Known as a super storm that touched ground in New Jersey as a category 1 hurricane that caused as much damage as a category 4 storm. New Jersey Transit was shut down in most areas and almost all shoreline cities were evacuated. Some of the highest reported storms in history of hurricanes to touch ground in the United States. The Jersey Shore was completely devastated.



ISLAND FRAGILITY 2.3



PROXIMITY TO REST OF ISLAND

With limited access to the island from the north or south ends it raises the potential risk of being unable to evacuate or leave the island in the event of and aftermath of a hurricane. Flood debris is a major cause of damage to houses and infrastructure which takes time to remove. The Barneget Light area of the island is furthest from the bridge to the island and has no other access point despite being closely located to Mantaloking to the north. Certain communities have also been developed on smaller islands off the bay area that share in vulnerability to storm damages as the bridge does. Communities located here will have difficulty leaving the island if the only access back to the island is blocked off. They might be less vulnerable to storm surge, but the effects of storm tide will affect here similar to other portions of the island.



LIMITED BEACH ACCESS

The beaches on the north end of Long Beach Island predominantly private. The majority of beach-front realstate is owned by private residents and rented out each year with the promise of peaceful and quiet beaches. The housing on the north end ranges more in the millions compared to the majority of areas such as Ship Bottom. The feeling on the north end is closely related to a private community where only the upper class can reside.





SINGULAR ISLAND ENTRY

Long Beach Island is one of the many barrier islands along the coast of New Jersey. Due to their distance off shore they utilize bridges in order to connect to the mainland. For Long Beach Island, only one bridge is being used as an access point. This could be a potential risk for residents if an when another hurricane like Hurricane Sandy were to cause more infrastructural damage as the water levels rise. In addition to only one bridge to get onto the island; there is only one primary road that is used to travel north and south on the island which in the event of storm washing up debris and sand onto the main road it creates a problem with transportation off the island.



LACK OF BAY DEVELOPMENT

The bay-side of Long Beach Island is just as susceptible to the effects of passing storms. The proximity to the bay leads to damaging erosion and scour from storm tide and despite rising water levels the depth of the bay is shallow and floods the island quickly. There is potential for the development of bay infrastructure to better mitigate and disperse flood waters and developing new series of docks for residences who do not live on the bay-side.





THINNING ISLAND PORTIONS

Beach Haven is one of the municipalities on the island that sits in a higher risk flood zone than areas like Ship Bottom which have a denser development and wider landscape. These thinner sections of the island will be the first areas to be swept away by a storm of submerged under rising water levels. They are greatly affected by the force of a storm surge as well as the damaging effects of a lingering storm tide. The beaches on the south end are also being pushed and carried towards the north end by the currents and thus in need of development. Money spent of beach nourishment is done in vain as dredging is an expensive and publicly unpleasant process and jetties are not a perfect solution to keeping sand in place. Houses directly on the beach-front are also more susceptible to foundation undermining as the beaches continue to wave away.

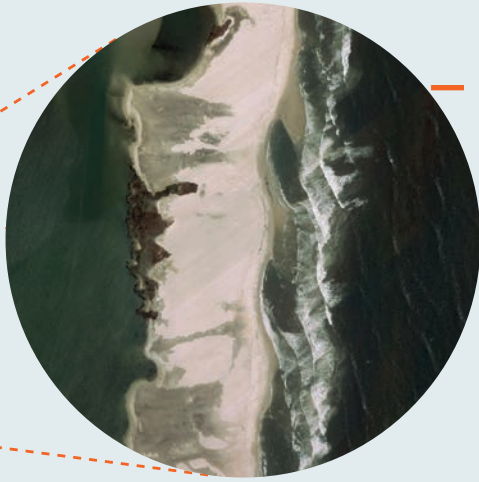

UNDEVELOPED SOUTHERN TIP

Southern tip of the island is only thin beach with no housing development. Not quite a wetland and not quite beach-front. There is potential for light development that is not necessarily housing or heavy infrastructure. The southern portion has potential for the design of boardwalk and beach cabanas that would exist for pleasant scenery and mild beach entertainment.



PAST DAMAGES 2.4

Based on the damages from previous storms, like superstorm Sandy, we begin to envision and evaluate the future damages. Storms are all unique in their destruction, but patterns exist in our own civil framework and without proper planning then we'll be doomed to have repeated damages. These are just a few images of what can be expected to occur time and time again in the wake of severe storms. This leads to speculation about the potential damages that could occur in a severe case of natural changes for Long Beach Island.

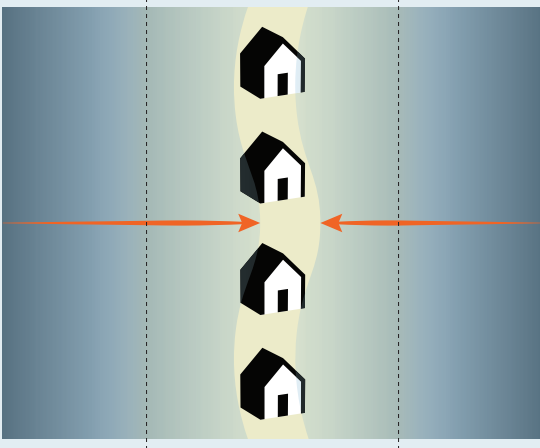
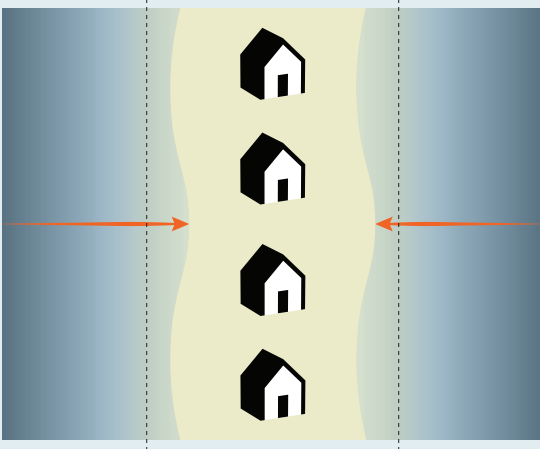
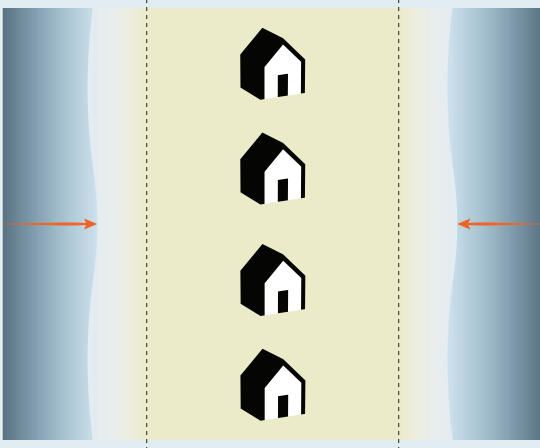

ISLAND SCENARIOS 2.5

SCENARIO A

The scenario A shows the worst case event of the ocean consuming the island as a whole.

The inevitable will occur along the east coast and sea level rise is going to submerge mostly all of the barrier islands along New Jersey. It is time for these cities to start maintaining their own betterment with a more economical strategy. Progressively converting these barrier islands to floating communities seems ideal to preserving the existing culture. This next step addresses a city slowly being consumed by the sea within the next 100 years.

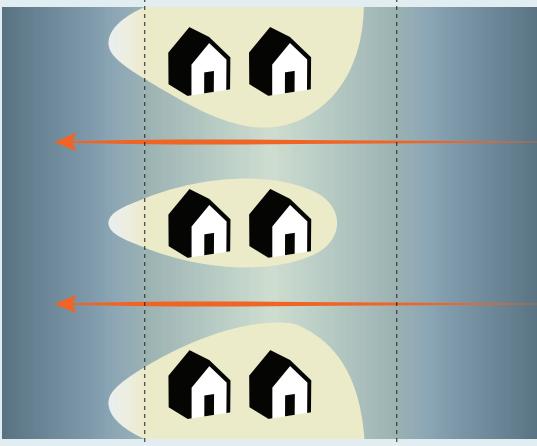
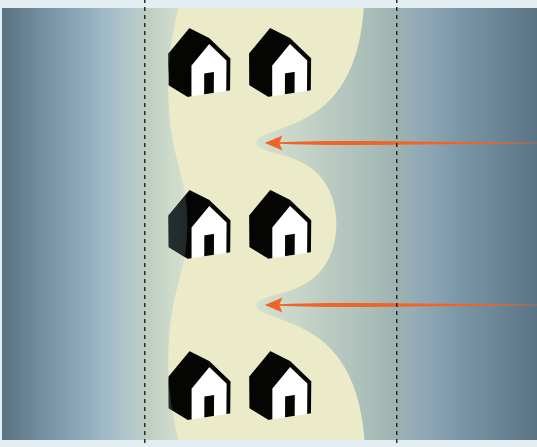
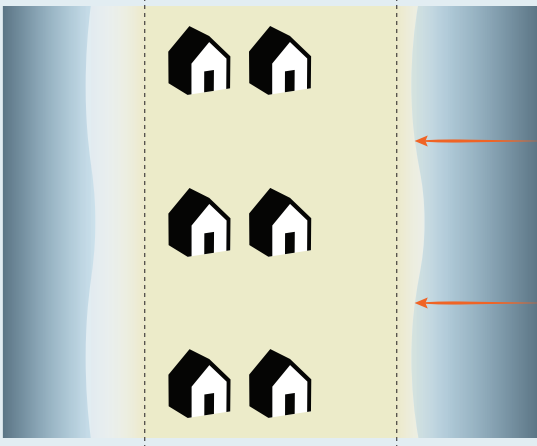

SCENARIO B

The scenario B shows the island physically being split into separate entities.

Long Beach island lacks a stable connecting value that binds the six municipalities together. Most islands have some kind of boardwalk or promenade to draw in locals and tourists for entertainment and economic values. A boardwalk would provide a new means of interest for the island as well as acts as the first line of defense against storms.

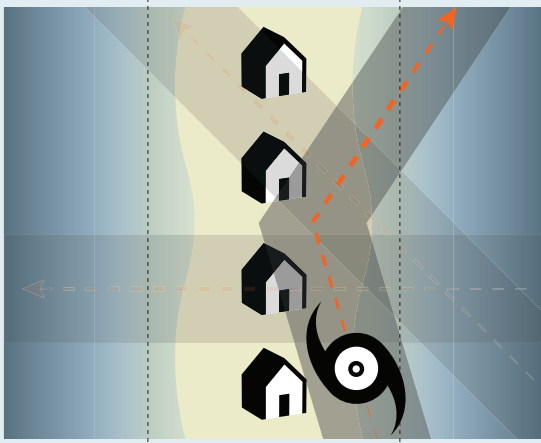
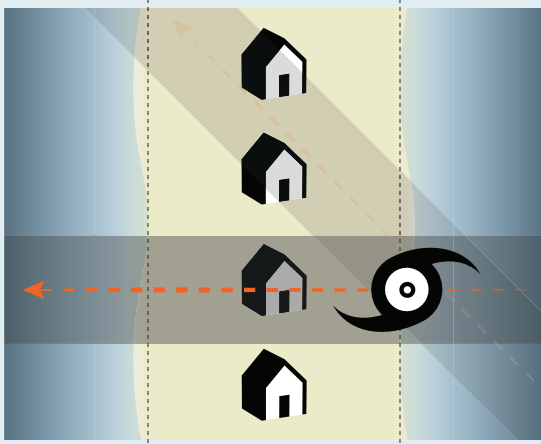
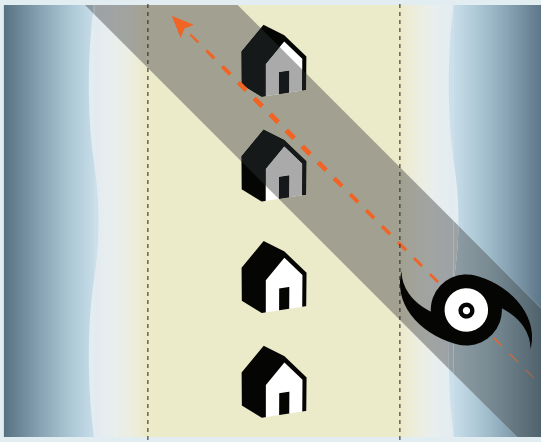

SCENARIO C

The scenario C shows certain portions of the island being wiped clean but still having a surface to rebuild upon.

A short succession of storms has assaulted the Jersey shore town of Long Beach Island and the damages from wind and flooding have left many communities ravaged of essentials. The island needs a new method of construction and living that will better stand up against future storms and sea level rise all together.

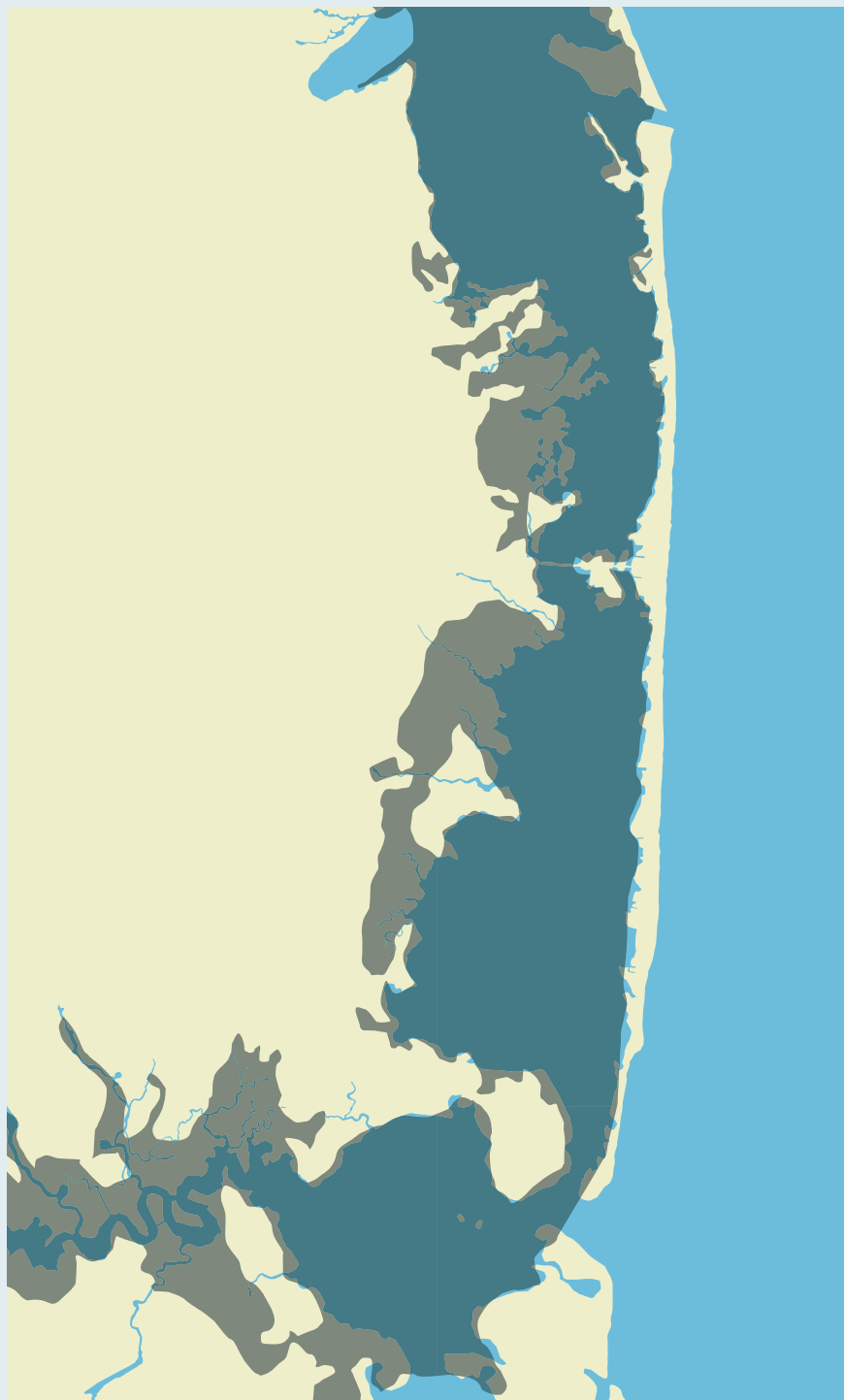

RISING WATERS 2.6

WATER LEVEL | 2050

By the year 2050 the sea is projected to rise about 19 inches. The image to the left shows the rising water levels of the bay overtaking the mainland and barrier island. This shows that even by 2050 the island is still mostly there and people will most likely continue to vacation on the island.

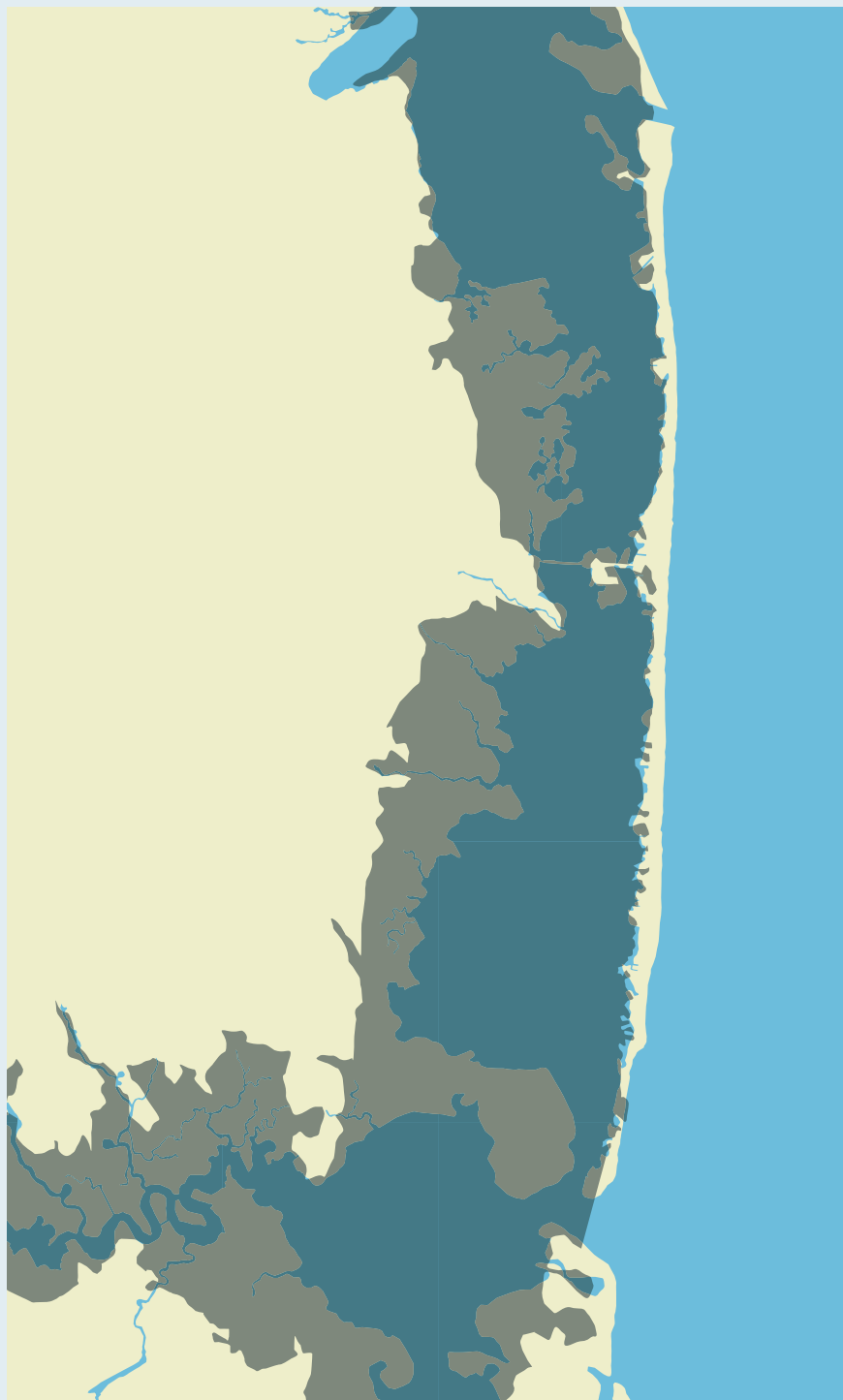

WATER LEVEL | 2100

This map shows the future water level projections of 2100. The sea is supposed to rise around 6 feet by then and as seen in the diagram the island is still strongly visible, but the mainland is being flooded even more. The barrier islands project from storm surges well, but the mainland is at a lower base floodplain elevation due to wetlands. Thus the mainland is the first area affected by the differed sea level rise. This shows us that there is still time a need for strategic design intelligence on the island.



FEMA GUIDELINES 3.1

PRESENT CONSTRUCTION

- *Mostly wood construction*
- *Materials do not stand up to storm/high winds or flooding*
- *Foundations not strong enough to withstand flooding/erosion*
- *Many older structures still around are not built up to FEMA's current coastal construction standard*
- *Most beach-homeowners want the "traditional" look of a shore house made of post and beam wood construction as opposed to more structurally stable pre-fab concrete systems*
- *Many homes are built on poor foundation and shift in the event of flooding*

FEMA COASTAL CONSTRUCTION

- *Up to date with the 2011 IRC and IBC building codes*
- *Biggest change in guidelines being the incorporation of an elevated concrete beam system for a stronger load capacity and foundation*
- *Some key design features of a project to mitigate:*
 - *Adding 1 to 2 feet from required elevation standard*
 - *Additional depth of pilings for foundation*
 - *Installing fewer breakaway walls or more openings in the foundation to reduce debris and damage to under-story*
 - *Use an open foundation system to reduce the potential for the structure to be damaged*
 - *Water flows around or through the building depending on the type of foundation*
 - *Cladding systems as opposed to vinyl siding*
 - *Asphalt roof shingles for stronger bonding to prevent blowing off in high winds*
 - *Using metal connectors or fasteners with thicker galvanized coated or stainless steel*



OPEN FOUNDATIONS

PRO

*Allows water to pass underneath, reducing lateral flood loads.
Less surface area exposed to waves and flooding.*

CON

*Lose of usable storage space.
Poor efficient use of land.*

CLOSED FOUNDATIONS

PRO

*None really, homeowner preference.
Not or recommended in most coastal zones.*

CON

Larger obstacle for waves and flooding streets that can create a scour (weakening of foundation soils) and undermine footings causing a collapse.



PILE FOUNDATION

When embedded properly they are structurally stable and resist scour and erosion.

Typically constructed out of timber, pre-cast concrete, or steel

- *Timber (Low cost and readily available, Easier assembly, Submerged timber is resistant to decay)*
- *Pre-Cast (Flexibility of dimensions, Corrosion resistant, High bending strength when reinforced)*
- *Steel (High resistance to bending, Many dimensions of steel, Can be driven through hard subsurface materials)*

FORTIFYING EXISTING STRUCTURES

Flood mitigation

- *Building elevation (pile construction)*
- *Relocating the building*
- *Constructing barriers (levees and flood-walls)*
- *Dry flood-proofing (sealants, closures, sump pumps, and back-flow valves)*
- *Wet flood-proofing (using flood damage-resistant materials and protecting utilities and contents).*

High Wind mitigation

- *Strengthen vents and soffits*
- *Strengthen gable end walls*
- *Protecting doors and windows from wind pressure and debris with impact resistant coverings*
- *Strengthening attached structures (porches, decks, carports) with additional bracing*

Flood Insurance Reform

① Premium at 4-feet below base flood elevation:
\$9,500 per year
\$95,000 per 10 years



② Premium at base flood elevation:
\$1,410 per year
\$14,100 per 10 years



③ Premium at 3 feet above base flood elevation:
\$427 per year
\$4,270 per 10 years



INSURANCE 3.2

Insurance is the economic form by which coastal dwellers can mitigate the storm damages in the event of a hurricane. The different insurance providers all package their own forms of home-owner's insurance, but not all standard homeowner packages provide true flood insurance.

Each type of package for flood insurance typically includes "flood-plain management solutions" in which homeowners are encouraged to purchase a "general risk insurance" package to reduce the socio-economic impact of flooding.

Wind Insurance is generally covered by most standard homeowner packages, but Atlantic coast states are in "high risk areas" and can apply for better wind coverage. For shoreline homes it provides coverage for high wind and wind-borne debris damages that can occur during a hurricane. Similar to flood insurance the packages also provide a series of management solutions by which to follow in order protect a house from wind damage.

The problems around these insurance packages however, are that not all damages from wind or flooding, are covered depending on what is actually damaged and the origin of water.

The biggest problem however is that under the National Flood Insurance program only covers around \$350,000 in damages. \$250,000 goes towards the structure of the house and the remaining \$100,000 goes towards personal belongings without exceeding either coverage amount. It is possible to buy "excess flood insurance" which has a additional \$250,000 deductible, but that deductible will naturally be paid out of pocket each year regardless of a storm or not.

The average price of a house on Long Beach Island is around \$1,000,000 and thus flood insurance in the event of an emergency will only cover 24% of the damages to the structure of the house; which does not cover too much in the long run.

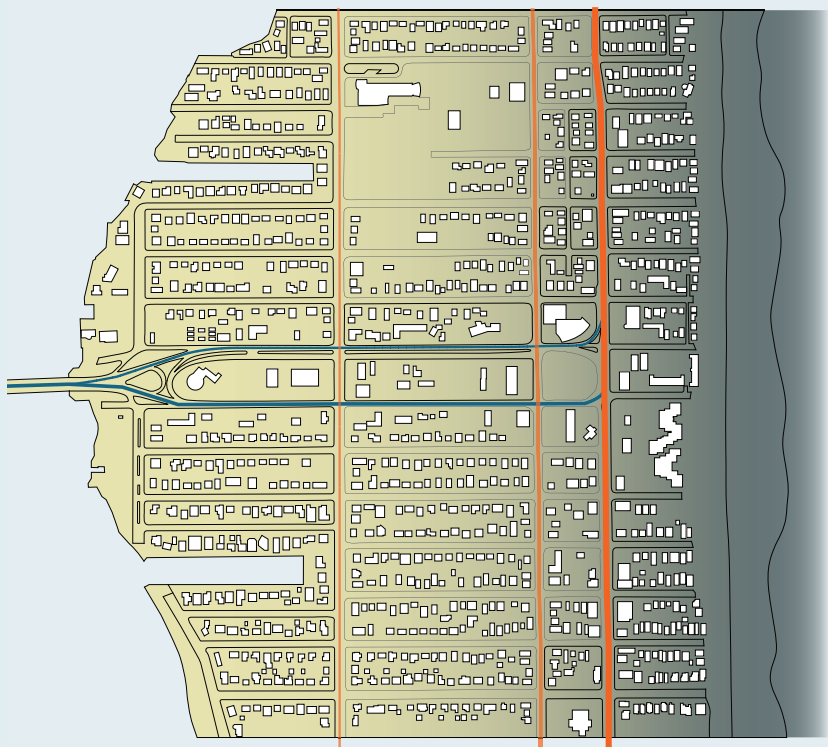

SITE MAPPING 4.1

SITE AXIS

Long Beach Island has one point of entry that leads into three main streets that run north and south along the island. Travel through the island is simple and just due to limited entry points it also means congestion when entering and leaving the island. Only the highlighted road closest to the beach runs the full length of the island. The location of that primary axis will prove to be a problem during a storm should damage be enough to put the road out of commission.

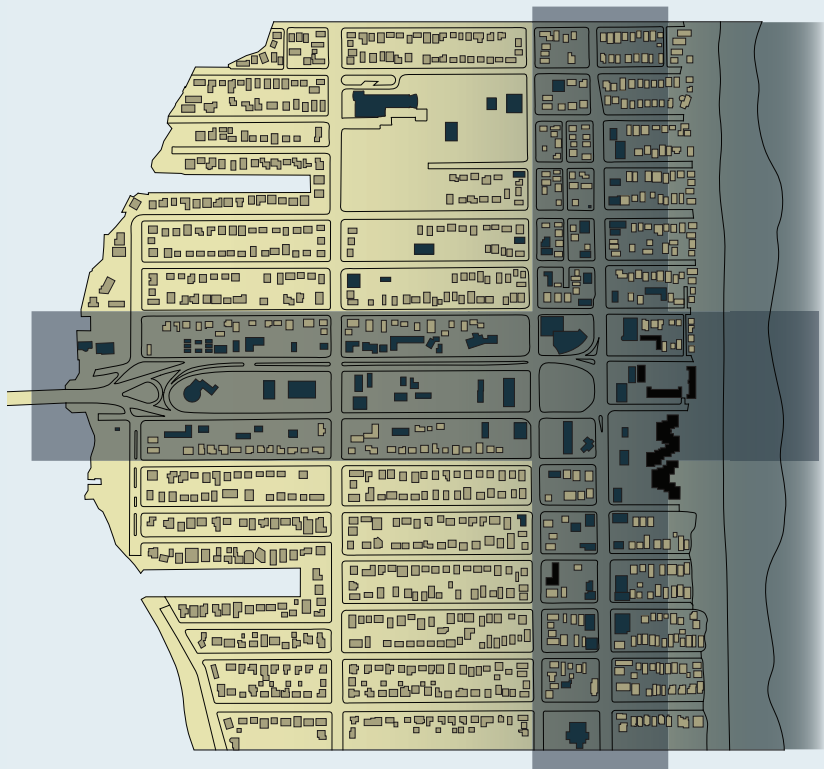

RESIDENCE & BUSINESS

There is a lot of housing on the island and the area of Ship Bottom is no exception. There are two main commercial zones on the island in which most of the shops and restaurants are located. Some mixed use housing lies on the main axis within the primary commercial zone. The majority of beach-front is dedicated to large houses and sit in the ideal location between beaches, bars, and restaurants.



SINGLE & MULTI FAMILY

Much of the housing in Ship Bottom is single family houses. Only a few multi-family houses are located in this municipality and the ones that are seem to typically be rent-able properties. The rest of residences in Ship Bottom are predominantly older style ranchers and a handful of double story houses. There is a mixing of tradition, modern, and vintage housing that makes up each city block. Depending on location the value of each house also varies.

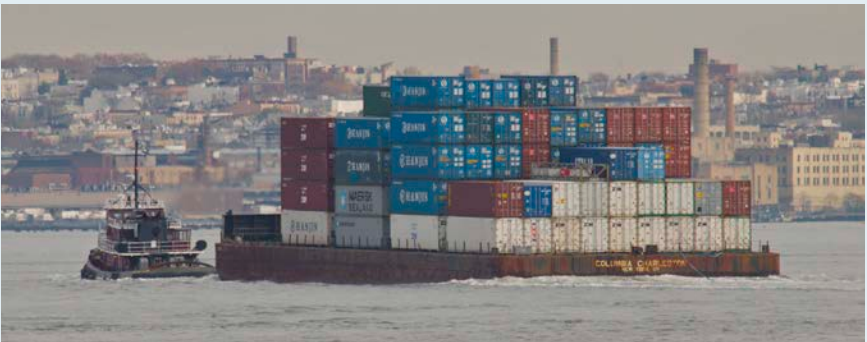
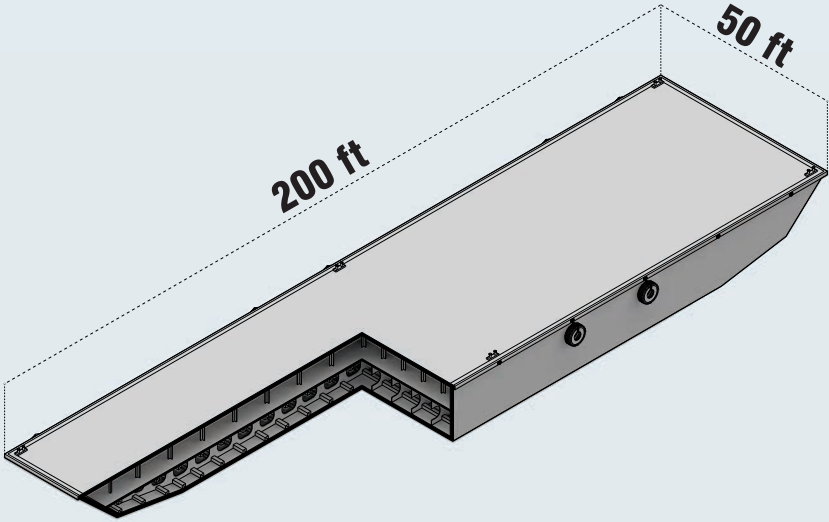

BARGES 5.1

WHY BARGES?

Barges can carry up to 1,500 tons of cargo each and are usually towed together with 15 barges. Depending on the weight of buildings on the barge we may be able to chain even more together in the event of emergency.

Our ideal barge would be 200 feet long and 50 feet wide. There are many barges for sale that can be transported and moored into place. Then construction on top of the barges while the necessary utility work is done below deck.

Barges are the ideal engine for the flotation of a new community. One barge can fit five houses but it could also fit a community center or a couple restaurants the potential is all depending on the layout of each barge.

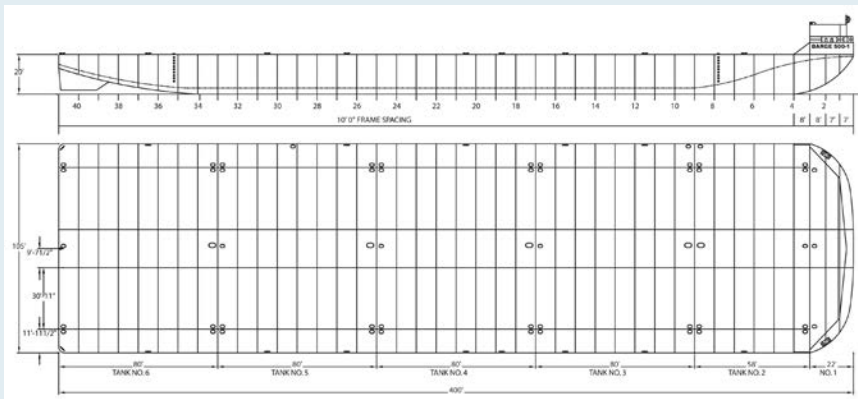

BARGE CONSTRUCTION

Barges are constructed based on the body of water they'll float on. For river barges, they are typically of steel construction with a short spanning distance for optimal stability. The hull design is not deep for proper stability of floating to prevent tipping due to waves.

Many architects have and are renovating existing barges into more usable program (as seen later in precedents). The idea of making a barge usable for something other than cargo bins is an interesting task but there exists much potential.

Whether we plan to construct our own barges or acquire and renovate existing river barges; they will ideally serve our purpose: to re-imagine a stable floating structure that can withstand the load of multiple structures.

BARGE DIVISION 5.2

PLANNING

When laying out the spacing of structures on the barge we will be taking into account many aspects relating to:

- *Height of structures on barge*
- *Weight of barge in total*
- *Density in plan*
- *Direction towards ocean*
- *Orientation towards sun*

PROGRAM

Beach towns are not based around just housing but have a variety of unique programs supporting them. We will be sustaining the existing framework of regional culture and developing new community hybrids on the barges. Some of the programs we plan to include are:

- *Housing*
- *Bars & Restaurants*
- *Community Center*
- *Boardwalk*
- *Beach space*

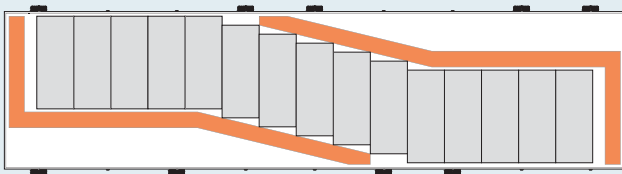
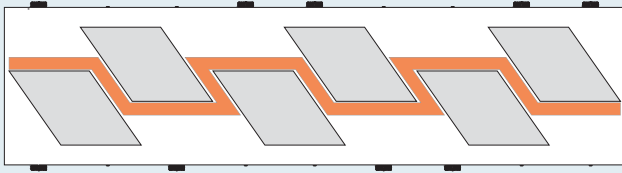
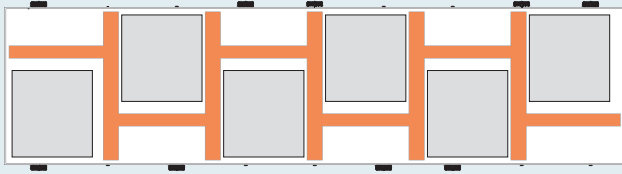
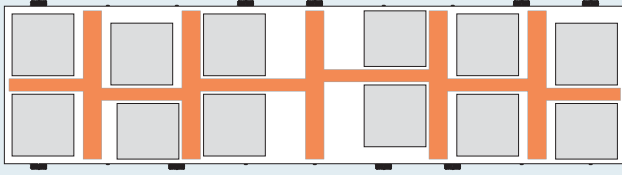
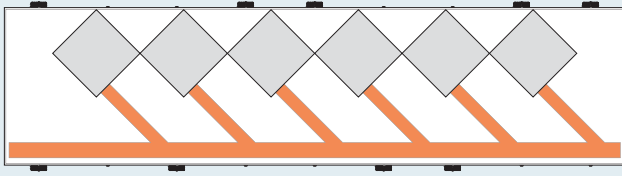

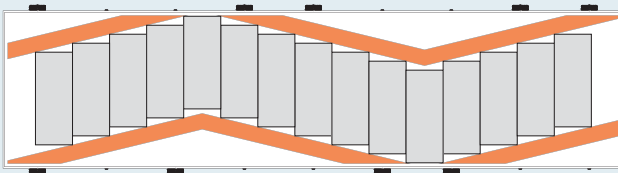
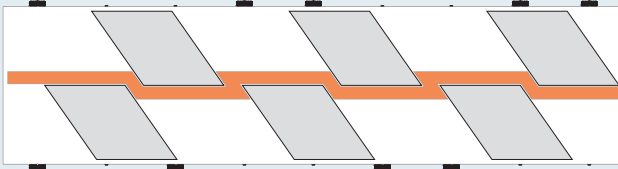
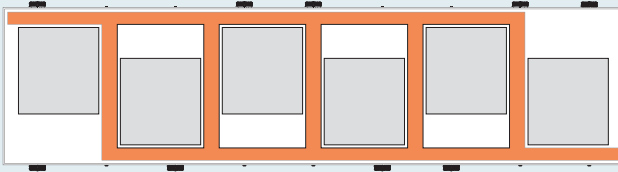
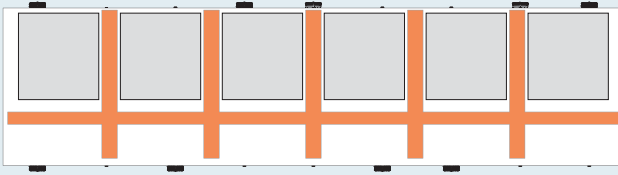
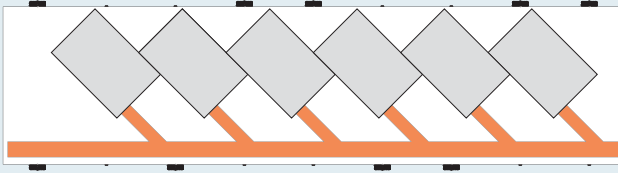

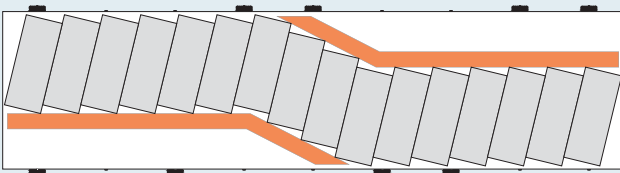
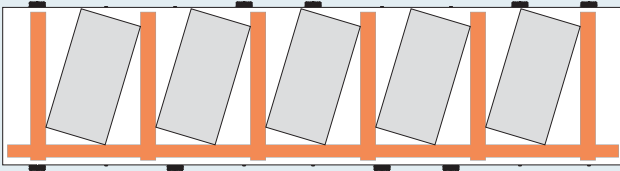
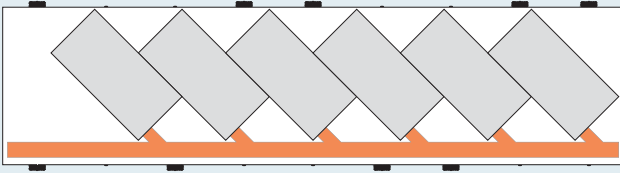
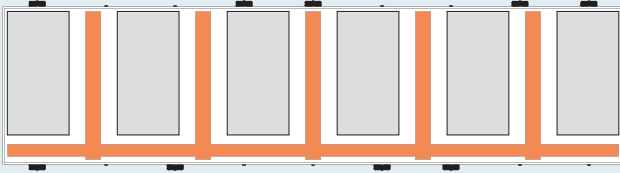
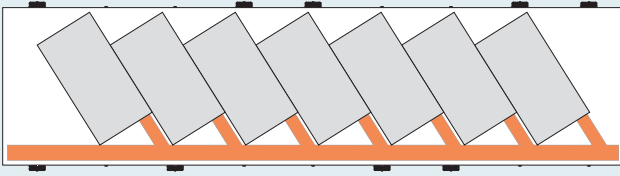

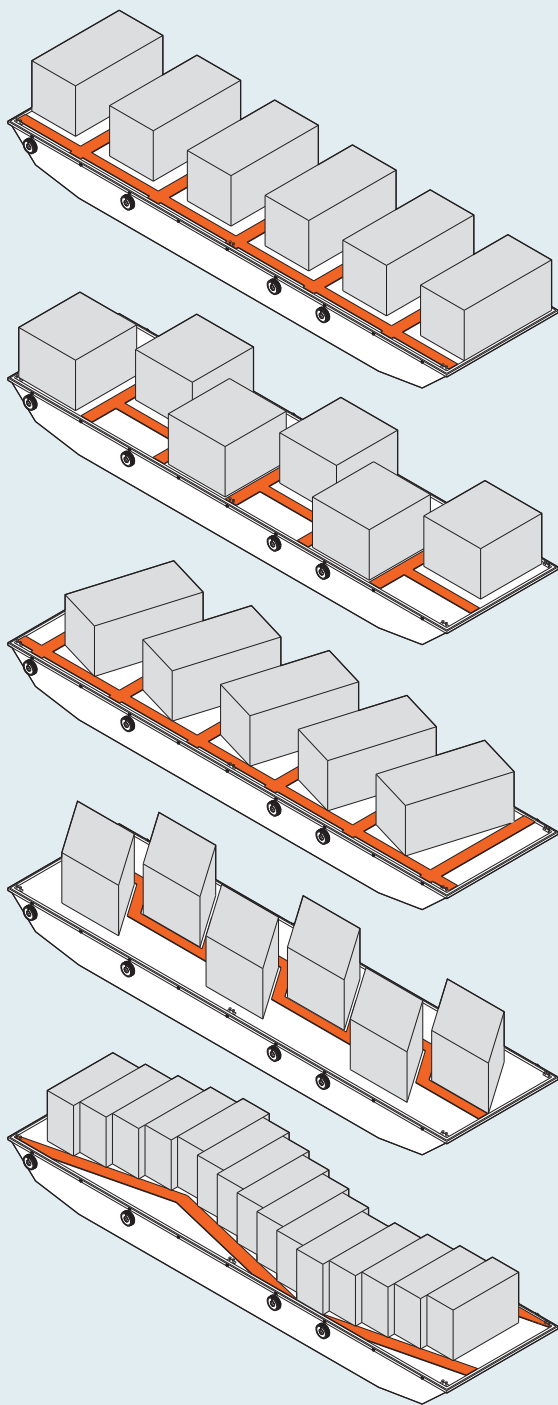



MAKING A DATUM 6.1

Long Beach Island lacks a stable connecting value that binds the six municipalities together. Most islands have some kind of boardwalk or promenade to draw in locals and tourists which is a staple for New Jersey. A boardwalk would provide a new means of interest for the island, as well as acts as the first line of defense against storms.

Depending on what scenario serves as the outcome for the island there may be a need for a potential connection point that helps reshape the island after a storm. Whether the boardwalk acts as a sturdy sea wall or an on-land attenuation strategy, the goal will be to design a new infrastructure that helps preserve beach culture.

The benefits of a boardwalk links together the economic hub for an island and gives beach goers a place to gather and spend time with family. Long Beach Island lacks a standard boardwalk and the addition of one would add a new datum for the island to be focused around. That new datum would then connect to the new barge communities to reinforce the core of what people travel to the Jersey shore for every summer. The boardwalk is a median between beaches, bars, and boarding.

Whether our designed boardwalk is a straight lined datum or ebbs and flows along the island; the connection between desired program and tourists exists to reinvigorate the island's economy and preserve one's sense of beach culture. The boardwalk can and will most likely respond to the scenario set in place.

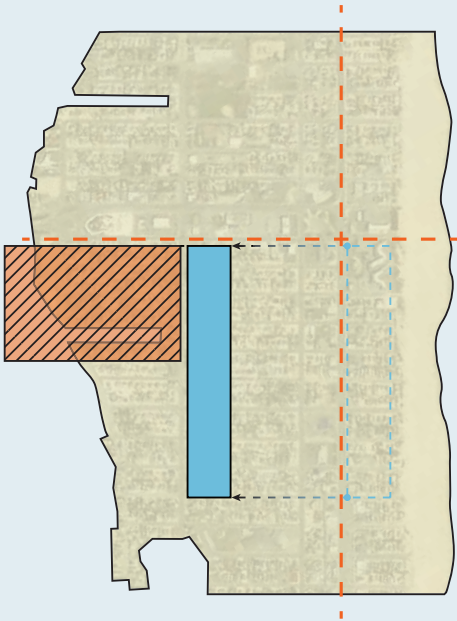
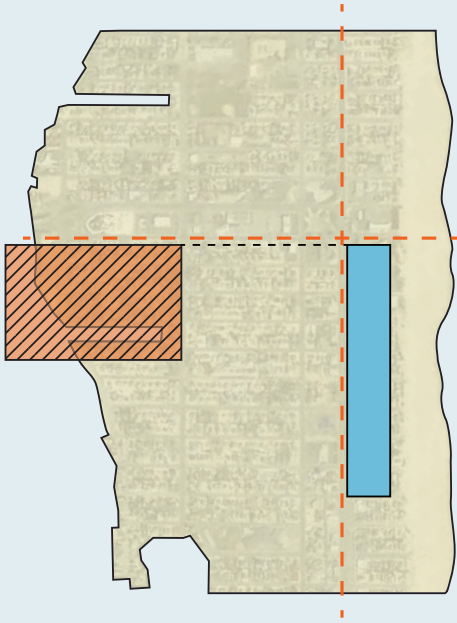

TRADITIONAL

The majority of boardwalks along the Jersey Shore are located front and center with the beach as the idea tourist destination for beach and boardwalk. It is the ideal place for people to take a break from the beach and grab a bite to eat or do a little shopping. The versatility of a boardwalk to function at all times of day make them needed in a central location. The area in question is right within the commercial zone of Ship Bottom and has easy bridge access.

SHIFTED IDENTITY

The other option as hand to take the idea of a traditional boardwalk and shift it to create a new identity for another part of the island; in this case the bay side where the barge interventions will go. The potential for a boardwalk to connect to the new community barges will lead to an adapted form of beach culture. All aspects of culture will be present but in a new area that would distribute value to more areas of the island.

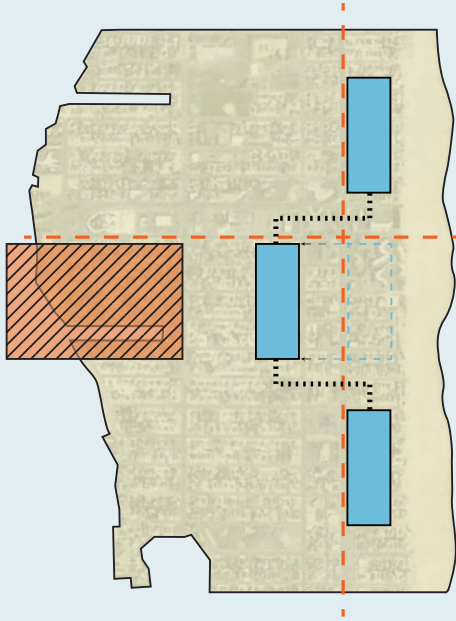
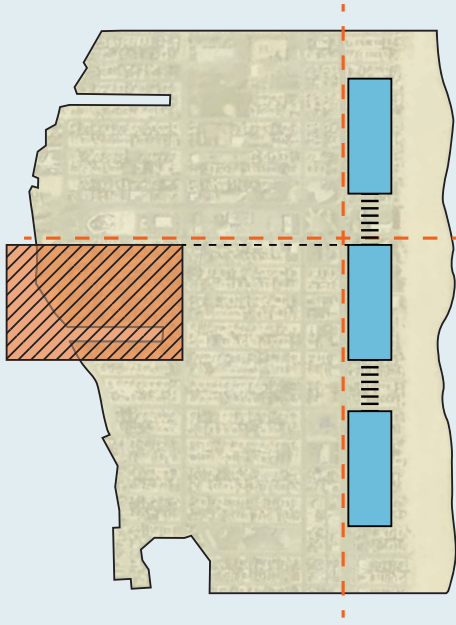

SEGMENTATION

Based on the ideals of a traditional boardwalk, but taking the concepts of mitigating storm damages to a new level. The boardwalk would be broken and shifted amongst Ship Bottom to create breaching points from breaking waves and diffusing the force of storm surges as a result of Hurricanes. The core values of a boardwalk remain in place, but add a new mitigation tactic to the design. Or, the possibility exists in which boardwalks and barges become one in a new floating economic hub along the coast.

SHIFTING CONNECTIONS

The last thing to considering in all the events of storms is that not all boardwalks can stand up to storms no matter how expertly constructed. In the event that a section of boardwalk is destroyed it gives the opportunity to reach out to other parts of the island and begin shifting to the new barge communities. This can occur overtime or be planned as such to create new connection values between each segment of boardwalk that identifies with different parts of the island. These shifting boardwalks may either be traditional or a hybrid of boardwalk-barges.

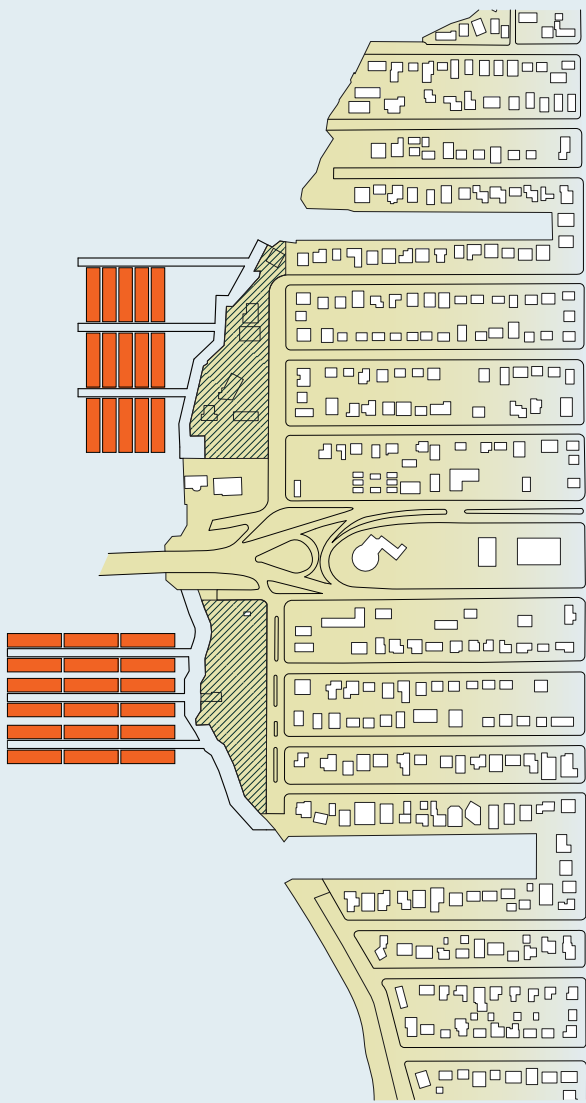

SITE STRATEGIES 6.2

ATTACH

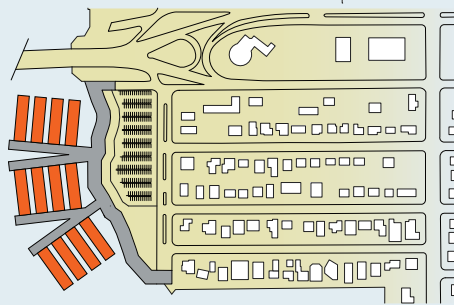
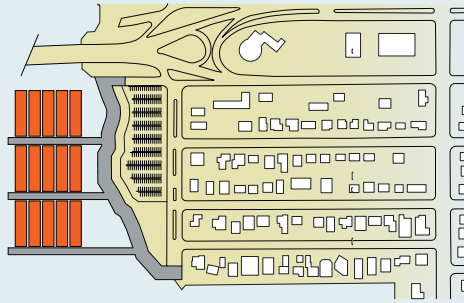
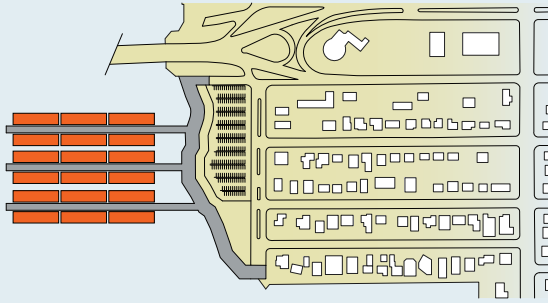

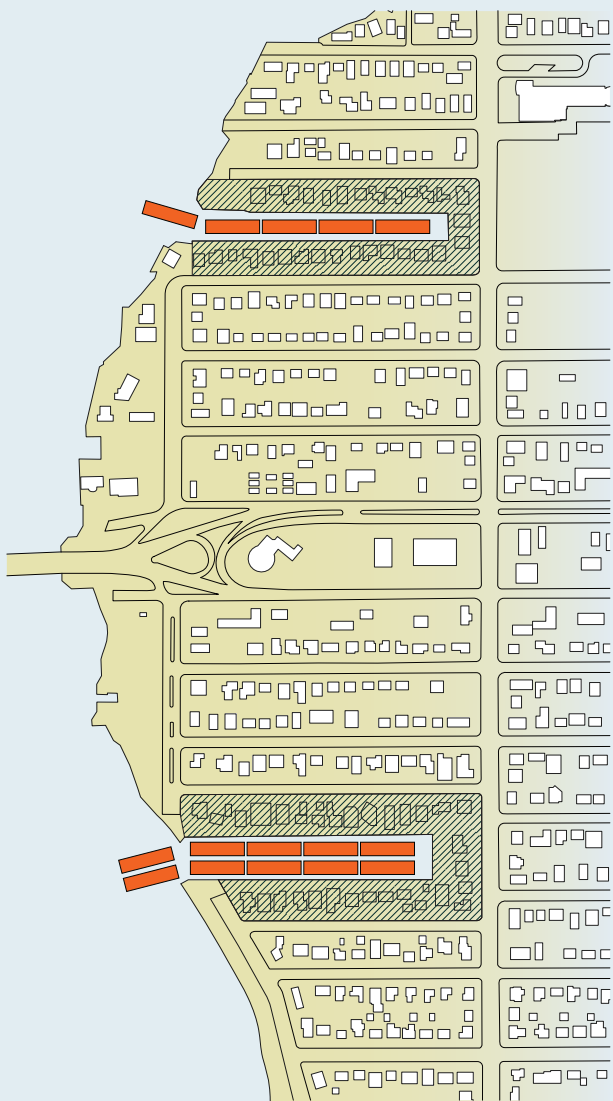

INSERT

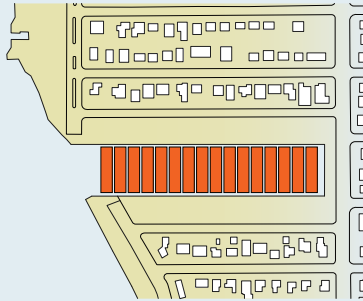

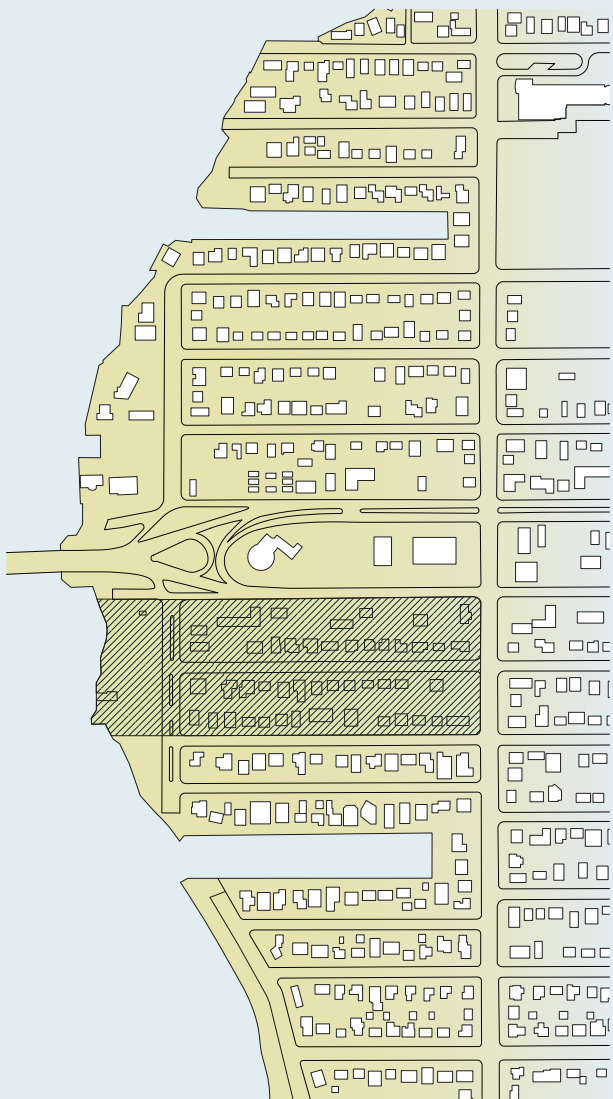

CARVE

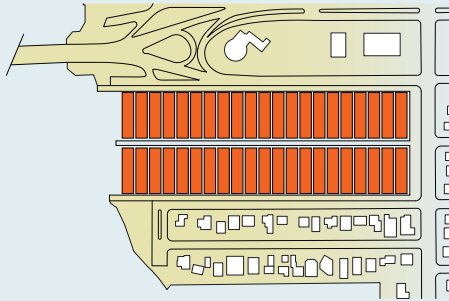
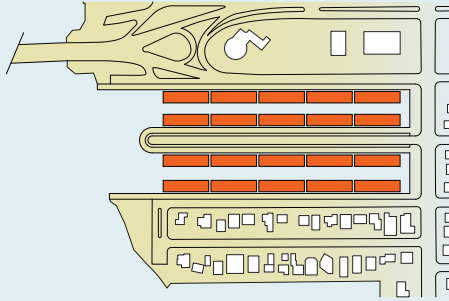

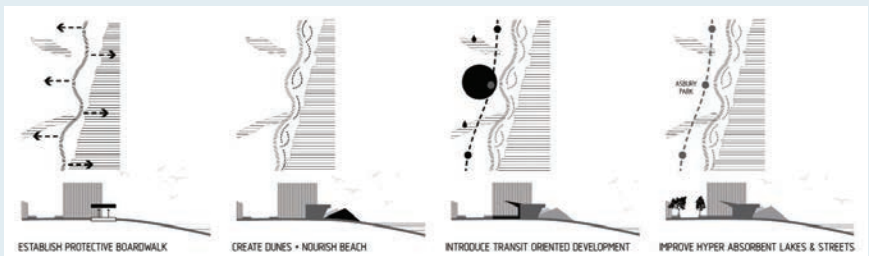
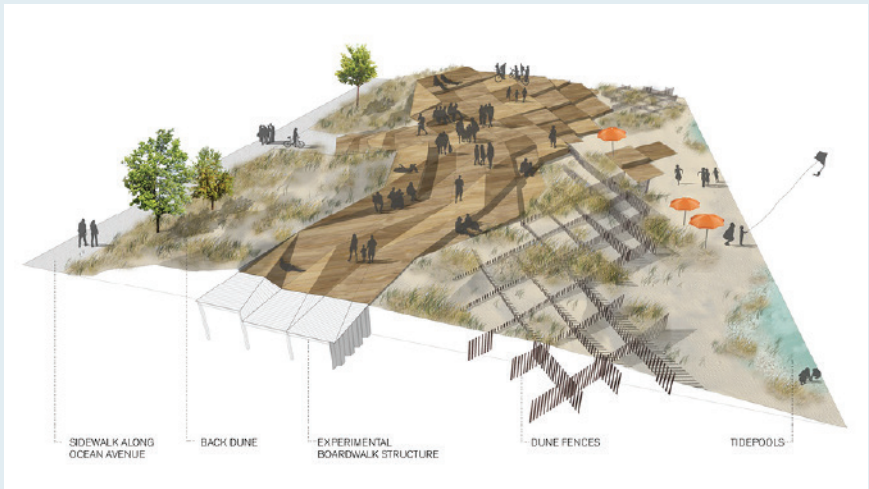
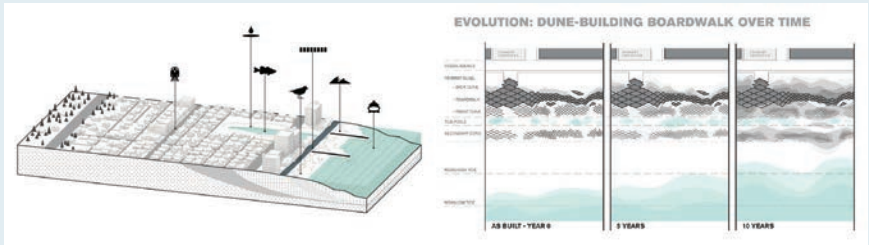

PRECEDENTS 7.1

REBUILD BY DESIGN

Sasaki & Partners participated in the Rebuild by Design competition post superstorm Sandy. Their entry was called the Headlands.

The competition entry focuses on the design of a new boardwalk that relates to resiliency of the beach and culture. It acts as the connection point between beach and city landscape.

Compared to some other designs, like that of SCAPE who focus more on landscape resiliency and returning the coasts to nature and reforming ecologies, The Headlands focuses more-so on the city and strengthening the important cultural nodes of the community.

The project brings in the best of both architecture and landscape as a method for invigorating the economy along side natural ecologies.



COLORFUL BEACH HUTS

Milford-on-Sea Beach Huts (left) and the rent-able beach huts (right) are both London based public access projects that enable users to enjoy their beach life in comfort.

The Milford-on-Sea Beach huts are a colorful group of huts designed by Snug Architects. These huts are both an economic source of entertainment for beach-goers and acts as a sea wall to re-direct the force of storm surges.

Combined with a boardwalk it becomes a central hub for tourists and locals.

The rent-able beach huts on the left serve a simple purpose, but lack the same effectiveness that the sea wall by Snug Architects. However, the benefit of combination of the two projects would produce a boardwalk seawall that not just brunts the force but could divert the power as well to break waves more effectively.







A. GELLER HOUSE

Andrew Geller created a series of houses in the Hamptons on Fire Island. The area itself in by no means a cheap community, but the houses themselves were designed in a such a way that they almost appear that they could wash-away.

While the idea of an architecture that just washes away does not seem ideal, the concept falls more in-line with cheap and weird architecture.

Each of his houses is unique in their own right and do not appear to break the bank on construction. Geller's houses and sketches also fall in line with our ideas for cabanas along the boardwalk.

We want to take his concepts and possibly combine them with an economic reasoning for a cheaper architecture that still looks interesting and performs a purpose connecting to preserving beach culture.







BARGE-ITECTURE

The Floating Office Barge by Marraum Architects is located in the Jubilee Wharf of London.

On a smaller scale, the barge works to create an economic floating office space that meets all the needs of a business while floating on the harbor. It creates both an interesting design challenge and business venture.

Though what we are considering for our proposal is on a much larger scale the projects gives a good idea about how to deal with certain amenities needed buildings on each barge. The type of construction would also prove to be a lightweight solution depending on program needed.

There are not many good projects created on barges, especially not large towboats, but the potential to design a well thought out project exists in referring to the work done here.

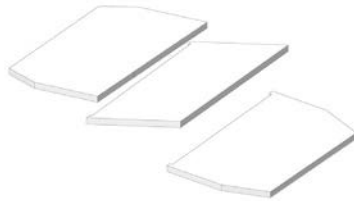

Roof
Construction



Wall & Floor
Construction

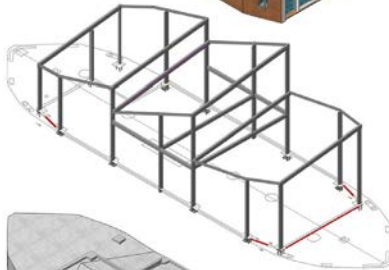

Steel Frame

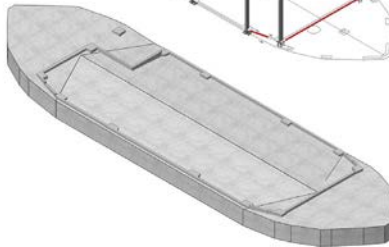

Existing
Concrete
Barge

"Brain of Brian"

Isometric Construction
NTS

mär[®]
raum

www.marraum.co.uk

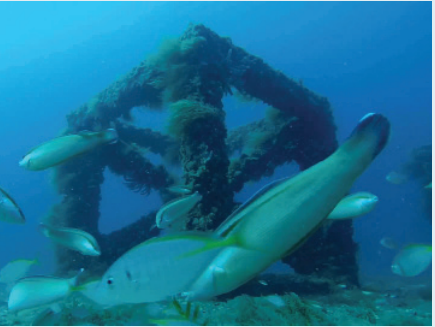
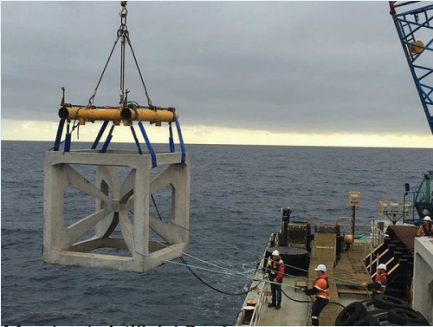

Mandurah Artificial Reef



Comprehensive Coastal Communities (3C) Competition Entries, ORLI organization

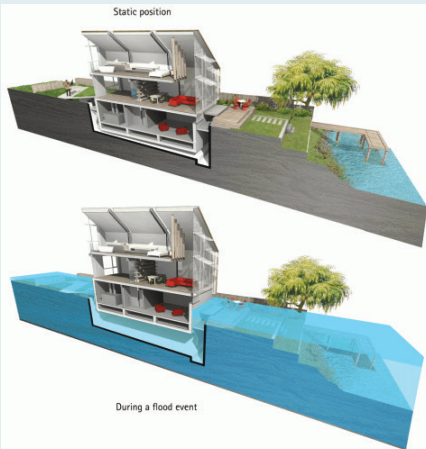

Amphibious House by Baca Architects on the River Thames of London

OTHER PRECEDENTS

Other precedents were examined early on before the idea of barges became a focus point. However, these projects still give an idea about viable options for developing on multiple levels that may come back into play during design.

Artificial Reefs are still a viable constructed object that can be mass produced on large scale at cheap cost. In the even they don't work to attenuate waves however they easily assimilate into their environment and become part of the ecosystem.

The 3C competition took place as a housing response to the aftermath of Hurricane Sandy much like Rebuild by Design. The concepts are not as fully thought out, but offer interesting insight into the way we can think about development of an architecture that looks at preserving regional culture.

Much like the houses of the 3C competition, but more technologically understood and thought out; the Amphibious House offers an obvious solution to a house that could suddenly become flooded. Early on the idea for our proposal was to create a series of houses much like this. This may not fall in line now with our barge communities, but the houses that adapt to natural occurrence are good to look at.

"All Proposals." *Rebuild by Design. The Rockefeller Founder*, n.d. Web. 29 Aug. 2016. <<http://www.rebuildbydesign.org/design-opportunities/>>.

Ammirato, Thom. "Hurricane Season Again, We're Done Waiting for Christie's Dunes." *Shore Group*. NJ.com, 04 Oct. 2016. Web. 14 Nov. 2016. <http://www.nj.com/opinion/index.ssf/2016/10/shore_group_were_done_waiting_for_christies_great_wall_of_sand_step_aside_opinion.html#incart_river_index>.

Architects, Snug. "Milford-on-Sea Beach Huts." *Snug Architects*. N.p., n.d. Web. 10 Nov. 2016. <<http://www.snugarchitects.co.uk/project/milford-on-sea-beach-huts/all>>.

Barker, Jacob. "Container Shipping on River Barges Could Boost St. Louis Freight." *St. Louis Post-Dispatch*. N.p., 06 Dec. 2016. Web. 8 Dec. 2016. <http://www.stltoday.com/business/local/container-shipping-on-river-barges-could-boost-st-louis-freight/article_745ef2ec-3229-555f-8beb-f1487d3bc384.html>.

"Barge and Towboat Facts." *Coosa- Alabama River Improvement Assn*. N.p., 02 Mar. 2016. Web. 26 Nov. 2016. <<http://www.caria.org/barge-and-towboat-facts/>>.

"Barge Weight Capacities Chart - Heartland Barge." *Heartland Barge*. N.p., n.d. Web. 26 Nov. 2016. <<http://www.heartlandbarge.com/barge-weight-capacities-chart/>>.

Bates, Todd B. "Superstorm Sandy Statistics for N.J., N.Y., Etc." *EnviroGuy*. Asbury Park Press, 20 Aug. 2013. Web. 05 Sept. 2016. <<http://blogs.app.com/enviro-guy/2013/08/20/superstorm-sandy-statistics-for-n-j-n-y-etc/>>.

"Beach Fishing NJ." Blog post. N.p., n.d. Web. 9 Dec. 2016. <http://beachfishingnj.blogspot.com/2011_08_01_archive.html>.

Bucci, Steven. "After Hurricane Sandy: Time to Learn and Implement the Lessons in Preparedness, Response, and Resilience." *The Heritage Foundation*. N.p., 24 Oct. 2013. Web. 15 Sept. 2016. <<http://www.heritage.org/research/reports/2013/10/after-hurricane-sandy-time-to-learn-and-implement-the-lessons>>.

"Coastal Flood and Wind Event Summaries." N.p.: n.p., n.d. N. pag. *Coastal Construction Manual Resources*. FEMA. Web. 7 Sept. 2016. <https://www.fema.gov/media-library-data/20130726-1509-20490-9998/ccm_res_coastal_flood_wind_event.pdf>.

SOURCES 8.1

Considine, Bob. "Businesses Struggle to Stay Afloat in Winter on Remote Long Beach Island." *NJ.com. Shore Group*, 11 Feb. 2011. Web. 31 Oct. 2016. <http://www.nj.com/news/index.ssf/2011/02/businesses_struggle_to_stay_af.html>.

Cross, David. "Lift Your House With Balloons: We Aren't Making This Up." *Movoto Blog*. N.p., 10 Nov. 2014. Web. 3 Dec. 2016. <<http://www.movoto.com/blog/novelty-real-estate/balloons/>>.

DiUlio, Nick. "Things May Have Changed A Lot on Long Beach Island Over the Years, But It's Still A Magic Place—www.njmonthly.com." *New Jersey Monthly*. N.p., 12 Mar. 2015. Web. 16 Dec. 2016. <<https://njmonthly.com/articles/jersey-shore/a-world-apart/>>.

Drye, Willie. "A Timeline of Hurricane Sandy's Path of Destruction." *Blog post. National Geographic Society (blogs)*. N.p., 03 Nov. 2012. Web. 2 Dec. 2016. <<http://voices.nationalgeographic.com/2012/11/02/a-timeline-of-hurricane-sandys-path-of-destruction/>>.

Dunn, Catherine. "Hurricane Sandy Victims Still Reckon With Insurance Underpayments 3 Years After Storm, Long Waits In FEMA Review." *International Business Times*. N.p., 05 Dec. 2015. Web. 22 Oct. 2016. <<http://www.ibtimes.com/hurricane-sandy-victims-still-reckon-insurance-underpayments-3-years-after-storm-long-2162035>>.

FEMA P-55, Coastal Construction Manual: Principles and Practices of Planning, Siting, Designing, Constructing, and Maintaining Residential Buildings in Coastal Areas, 4th Edition (2011) | FEMA.gov. FEMA, n.d. Web. 16 Sept. 2016. <<https://www.fema.gov/media-library/assets/documents/3293>>.

"Home, Sweet Home : Reese House à Long Island De L'architecte Andrew Geller." *Blog post. De Paysage En Paysage*. N.p., 31 Oct. 2015. Web. 1 Dec. 2016. <<https://enkidoublog.com/2015/10/31/home-sweet-home-reese-house-a-long-island-de-larchitecte-andrew-geller-1957/>>.

"Hurricanes." *NOAA*. N.p., n.d. Web. 7 Sept. 2016. <<https://coast.noaa.gov/hurricanes/>>.

"Hurricane Irene Recovery." *Points of Light*. N.p., 13 July 2012. Web. 9 Dec. 2016. <<http://www.pointsoflight.org/blog/2011/08/29/hurricane-irene-recovery>>.

"Hurricane Sandy and Insurance: FAQs." Insurance Information Institute. N.p., n.d. Web. 18 Sept. 2016. <<http://www.iii.org/article/hurricane-sandy-and-insurance-faqs>>.

Hutchins, Ryan. "Extensive Damage from Sandy Litters Long Beach Island." NJ.com. Shore Group, 31 Oct. 2012. Web. 3 Oct. 2016. <http://www.nj.com/news/index.ssf/2012/10/extensive_damage_from_sandy_li.html>.

"Long Beach Township: Background." Long Beach Township: Background - TripAdvisor. TripAdvisor, n.d. Web. 23 Sept. 2016. <<https://www.tripadvisor.com/Travel-g46581-s2/Long-Beach-Township:Long-Beach-Island:Background.html>>.

"Lytham St Annes." Beach Hut Day Rental. N.p., n.d. Web. 10 Nov. 2016. <<http://www.stannesbeachhuts.co.uk/beach-hut-day-rental/>>.

Mairs, Jessica. "Colourful Beach Huts and Promenade Integrated into Coastal Defence Wall." Dezeen. N.p., 21 Sept. 2016. Web. 10 Nov. 2016. <<https://www.dezeen.com/2016/09/21/colourful-beach-huts-promenade-coastal-defence-wall-snug-architects-southern-england/>>.

Newman, Andy. "Hurricane Sandy: Covering the Storm." The New York Times. The New York Times, 27 Oct. 2012. Web. 15 Oct. 2016. <http://www.nytimes.com/interactive/2012/10/28/nyregion/hurricane-sandy.html?_r=0>.

"Ocean City NJ Boardwalk Top Five Shops." The Best in Ocean City NJ. Leisure Group Travel, 27 Apr. 2016. Web. 20 Nov. 2016. <<http://oceancitynjblog.com/ocean-city-nj-boardwalk/>>.

Pope, Paige K. "A Boardwalk Bonanza Awaits Beach-goers in New Jersey •." Leisure Group Travel. Leisure Group Travel Magazine, 13 June 2016. Web. 2 Dec. 2016. <<http://leisuregrouptravel.com/a-boardwalk-bonanza-awaits-beach-goers-in-new-jersey/>>.

Salant, Jonathan D. "FEMA to Overhaul Flood Insurance Program after Sandy Complaints." NJ.com. N.p., 23 May 2016. Web. 12 Oct. 2016. <http://www.nj.com/politics/index.ssf/2016/05/fema_to_overhaul_flood_insurance_program_after_san.html>.

Sharp, Tim. "Superstorm Sandy: Facts About the Frankenstorm." LiveScience. Purch, 27 Nov. 2012. Web. 10 Oct. 2016. <<http://www.livescience.com/24380-hurricane-sandy-status-data.html>>.

"Storm Surge Overview." *Storm Surge Overview. National Oceanic and Atmospheric Administration*, n.d. Web. 01 Sept. 2016. <<http://www.nhc.noaa.gov/surge/>>.

Sullivan, S. P. "More than 70 People Have Been Charged with Sandy Fraud since the Storm." *NJ.com. Shore Group*, 22 Aug. 2016. Web. 20 Oct. 2016. <http://www.nj.com/news/index.ssf/2016/08/more_than_70_people_have_been_charged_with_sandy_f.html>.

Tepfenhart, Ossiana. "The 10 Worst Storms To Hit New Jersey." *FunNewJersey Magazine. N.p.*, 8 Sept. 2015. Web. 9 Dec. 2016. <<https://magazine.funnewjersey.com/the-10-worst-storms-to-hit-new-jersey/>>.

"The "Brain of Brian" Floating Office Barge / Marraum Architecture." *ArchDaily. N.p.*, 10 Apr. 2015. Web. 3 Dec. 2016. <<http://www.archdaily.com/617868/the-brain-of-brian-floating-office-barge-marraum-architecture>>.

The Texas Eagle: MacArthur Bridge. 2010. By Michael Minn. Web. 16 Dec. 2016. <https://michaelminn.net/railroads/amtrak/texas_eagle/macarthur_bridge>.

Thompson, Jody A. *Navigating the National Flood Insurance Program. Auburn University Marine Extension & Research Center*, June 2007. Web. 23 Sept. 2016. <http://www.aces.edu/dept/fisheries/aumerc/publications/documents/National-FloodInsuranceFactSheet_aces.pdf>.

Tingle, Alex. "Global Sea Level Rise Map." *Geology.com. N.p.*, n.d. Web. 10 Sept. 2016. <<http://flood.firetree.net/?ll=39.6452,-74.1819&zoom=13&m=0>>.

"Towboats and Barges of the Middle Mississippi River Valley." *Great River Road. N.p.*, n.d. Web. 26 Nov. 2016. <<http://www.greatriverroad.com/all/towboats.htm>>.

"Towmasters: The Master of Towing Vessels Assoc. Forum." *Wordpress*, 15 Aug. 2015. Web. 29 Nov. 2016. <<https://towmasters.wordpress.com/>>.

Webley, Kayla. "Hurricane Sandy By the Numbers: A Superstorm's Statistics, One Month Later | TIME.com." *Ecocentric. Time*, 26 Nov. 2012. Web. 3 Nov. 2016. <<http://nation.time.com/2012/11/26/hurricane-sandy-one-month-later/?i-id=sr-link2>>.