

1-1-1994

## European Beads from Spanish-Colonial Lamanai and Tipu, Belize

Marvin T. Smith

Elizabeth Graham

David M. Pendergast

Follow this and additional works at: <https://surface.syr.edu/beads>



Part of the [Archaeological Anthropology Commons](#), [History of Art, Architecture, and Archaeology Commons](#), [Science and Technology Studies Commons](#), and the [Social and Cultural Anthropology Commons](#)

---

### Repository Citation

Smith, Marvin T.; Graham, Elizabeth; and Pendergast, David M. (1994). "European Beads from Spanish-Colonial Lamanai and Tipu, Belize." *BEADS: Journal of the Society of Bead Researchers* 6: 21-47. Available at: <https://surface.syr.edu/beads/vol6/iss1/5>

This Article is brought to you for free and open access by SURFACE. It has been accepted for inclusion in BEADS: Journal of the Society of Bead Researchers by an authorized editor of SURFACE. For more information, please contact [surface@syr.edu](mailto:surface@syr.edu).

# EUROPEAN BEADS FROM SPANISH-COLONIAL LAMANAI AND TIPU, BELIZE

Marvin T. Smith, Elizabeth Graham and David M. Pendergast

*Excavation of the contact-period components of the Maya sites of Lamanai and Tipu in northern and west-central Belize, respectively, have yielded moderate collections of European glass and other beads. The archaeological data are augmented by ethnohistorical documentation regarding the length of Mayan/Spanish interaction. Contexts do not provide unequivocal stratigraphic evidence of sequential bead importation, but known dates of bead varieties assist in refining both site chronology and the understanding of bead use. As the first Central American collections to be analyzed, the two assemblages offer an initial glimpse of one aspect of European impact on native material and non-material culture.*

## INTRODUCTION

Excavation of the Spanish Colonial portions of Lamanai, in north central Belize, and Tipu, near the country's western border (Fig. 1), has provided the first archaeological documentation of 16th- and 17th-century Maya life in the southern lowlands. The work at Lamanai, begun in 1975 and completed in 1986 (Pendergast 1981, 1986a-b, 1990, 1991), comprised full excavation of every identifiable residential structure of the colonial settlement, as well as the two sequent Spanish churches and several non-structure-associated refuse dumps of the period. One of the two contact-period cemeteries was completely excavated, whereas the second (and probably later of the two) saw only the most minimal sampling (Pendergast 1986b:4). In contrast, the Tipu project has, since its initiation in 1980, involved excavation of the single identifiable church and its more than 600 associated burials (Cohen, Bennett and Armstrong 1989), as well as investigation of eight colonial residences (Graham 1991; Graham and

Bennett 1989; Graham, Jones and Kautz 1985). Insofar as the church and Spanish-period cemetery are concerned, the sample of the colonial remains at the site is largely complete; only a portion of the sanctuary was left unexcavated. Of what we estimate to be the colonial community, less than one-third has been excavated.

Despite the differences in sample size and character at the two sites, there is a strong suggestion that colonial-period material culture contrasts between Lamanai and Tipu are more than an artifact of excavation. The contrasts are, in fact, very likely to reflect significantly different relations between Maya and Spaniard in communities that played largely separate roles on the early colonial stage (*see* Graham, Pendergast and Jones 1989). Although the archaeological record from the two communities includes parallels in some areas of European material culture, the contexts and types of glass beads at the two sites overlap only partially. The differences in extent of excavation of the sites may have some degree of bearing on this aspect of sample comparability (Pendergast 1991:350), but there is very good reason to suppose that imported beads were utilized at Lamanai in ways different from those that characterized Tipu.

In addition to their value as sources of information regarding native status and European economic impact in the two communities, the Lamanai and Tipu bead collections are the first from Central America to be analyzed. They are, therefore, useful as evidence of the bead varieties that figured in early contact in the area. The grave-lot associations at Tipu also bear on bead chronology, and some suggestions regarding chronology are made in this paper. It is important to note, however, that the details of burial sequence



Figure 1. Map of Belize showing the location of Lamanai and Tipu, as well as other archaeological sites (drawing by D. Findlay).



**Figure 2.** Structure N11-18 at Lamanai, the source of most of the site's beads and probable home of the community's *alcalde* (photo by D. Pendergast).

derive from a wide range of data and cannot be worked out in full until all analyses are completed.

Full discussion of the Tipu and Lamanai assemblages will appear in excavation reporting, but we present here a summary of the contexts in which the two bead collections were encountered. Most of the beads are glass, but some jet and amber are also included. The bead descriptions, the type and variety designations and the dating based on typology are the work of Smith; the discussions of the archaeological contexts, associated artifacts and the probable significance of the two collections were written by Graham (Tipu) and Pendergast (Lamanai).

#### **THE LAMANAI BEAD SAMPLE: CONTEXTS**

With a small number of exceptions, the 16th-century Lamanai glass beads come from a restricted but, nonetheless, complex context: a residence designated Structure N11-18 (Fig. 2) (Pendergast 1991:348-350, Fig. 16-4). Together with

a variety of other European goods, the beads serve to identify with virtual certainty the principal Spanish colonial-period Maya residence, presumably the home of the settlement's *alcalde* (mayor) (Pendergast and Graham 1993). One of the two principal lots of beads (18 specimens; *see* Table 1), was recovered from a large midden that abutted the north face of the structure. The second lot consists of 20 beads, 14 of which were scattered over the interior of the house, a context that yielded a broad range of other European goods (Pendergast and Graham 1993:345-351), with the remaining six distributed on exterior floor surfaces at the front of the structure. The beads' presence immediately atop floor ballast and other building surfaces leaves no doubt that they were strewn throughout the structure as part of a deposition of wealth/status items that must, given the context, have been among the last acts that preceded abandonment of the residence. The meaning of the effort cannot be fully reconstructed, but it is highly likely that the discarding of previously valued

**Table 1. Lamanai Bead Varieties by Provenience.**

<b>Provenience</b>	<b>Variety</b>	<b>Quantity</b>
Structure N11-18, certainly or probably in core	IIa2a2	2
Structure N11-18, midden at north face of platform	IIA1e IIA2a IIIA2a IIIA2b IIIC2a IVA4c IVC2e IB4f	3 3 5 3 1 1 1 1
Structure N11-18, exterior building surfaces	IIA2a IIA2b IIIA2a IIIC2a	1 1 3 1
Structure N11-18, interior building surfaces	IIA1e IIA2a IIA2b IIIA1a IIIA2a IIIA2b IVA4c IVC2e?	1 4 1 1 3 1 1 1
Midden, south face of Structure N11-7 platform	IIIA2b	1
Structure N12-26	IIIA2a IIIA2b	1 1
West of N12-26, no structural association	IIIA2a	1
Structure N12-30	WIb11	2
<b>TOTAL</b>		<b>45</b>

European objects was part of a rejection of many aspects of Spanish influence over the community.

Certainly in use for longer than most or all of the midden specimens, the interior and exterior surface beads from the building are very likely to have been deposited a good many decades after their arrival at Lamanai. Although the suggestion that the beads were retained for so long a period raises a rather difficult conceptual problem, the argument for cessation of Structure N11-18's use during the opening years of the rebellion is a compelling one. First, abandonment of the structure at an earlier date would have meant the casting aside of a variety of imported goods, including the beads, by a still-functioning community under at least nominal Spanish control. Second, the absence of another Colonial structure equal to N11-18 in size, complexity and artifact content demonstrates that, if N11-18 had been abandoned early, the *alcalde* would have been left with neither house nor European goods as indicators of his rank at a time when he still administered the settlement. Finally, the construction of a substantial church (the second built in the community) probably not long before 1600 (Pendergast 1986b:3-4, 1993:123-124), is an indication of the importance of Spanish endeavors at the site over a protracted period. In this context, early rejection of Spanish goods, especially as there was so small a quantity of them in the community, seems highly improbable.

Owing both to the structure-related source of the beads and to the nature of more narrowly defined contexts within that source, the sample tells us only about elite material perquisites and not about either the motivations or the mechanisms of introduction of the beads to Lamanai. Given the volume and apparent age range of the sample, it is possible, but not particularly likely, that the entire lot represents a single importation. It is equally possible that the lot was intended as a gift to the *alcalde* to assist in establishing his identity as the native wielder of power substantiated by Spanish rule. It is obvious, however, that this, as well as alternative interpretations, must remain speculation because of the limitations imposed by the context. The documented role of priests in the introduction of beads, among other gifts, to native communities (van Oss 1986:16; Villagutierre Soto-Mayor 1983:246, 282, 288, 363) is no more

apparent in the Lamanai sample than is any secular concern.

Three other contexts, all but one of which are structure-related, proved to be minor sources of early contact-period beads; the total from the three sources is four specimens. An additional two beads (Kidd variety W1b11) come from Structure N12-30, a building approximately 400 meters south of N11-18 that was almost certainly also a residence. N12-30 is highly likely to have been a building of considerable importance, on grounds of its location in the vicinity of the second church, probably built early in the 17th century (Graham, Pendergast and Jones 1989:1256, Fig. 2). The beads appear to confirm the date posited on locational grounds.

#### **THE LAMANAI BEAD SAMPLE: CHRONOLOGICAL BRACKETING**

Apart from the evidence of the beads themselves, there is only a general chronological bracketing within which the contexts of the bead sample can be placed. Documentary evidence fixes the date of establishment of at least nominal Spanish rule of the frontier territory in which both Lamanai and Tipu lie as 1544 (Graham, Pendergast and Jones 1989:1256). It is probable that construction of the first church at Lamanai (*see* Pendergast 1986b:1, 1991:341-343) began not long after this date, and erection or amplification of the putative *alcalde*'s residence may date from this period as well. If the community's leader retained his authority in the face of declining Spanish control early in the 17th century, Structure N11-18 may have remained in use until the final events of the rebellion that Lamanai and Tipu had joined by 1638. On their arrival at Lamanai sometime near mid-1641, a group of Franciscan priests found the church and other buildings burnt and the populace supposedly decamped into the forest (López de Cogolludo 1971:Book 11, Chapter 13). The deposition of beads in midden adjacent to N11-18, and probably of those found in association with other structures, surely predates these events by some years. The specimens found within the confines of N11-18 are, in contrast, most likely to have been deposited very close to the last stage of the rebellion.

**Table 2. Non-Burial Bead Associations at Tipu.**

Lot Number	Context	Bead Dates	Variety and Quantity
T-004	Str. H12-6: collapse debris, east wall.	Pre-1560?	S&G IIA2a [1]
T-101	Str. H12-7: the bead was found in the upper 15 cm while clearing the area just to the east of the structure.		Kidd IVa*(a) [1]
T-150	Str. H12-8: the sole amber bead was encountered in a dark midden deposit below post-abandonment accumulation and above structural features ca. 18-28 cm below ground surface in the central trench.		Amber var. 1 [1]
T-151	Str. H12-18: post-abandonment accumulation, 12 cm below ground surface in the south trench.	pre-1560?	S&G IIIA2a [1]
T-156	Str. H12-18: post-abandonment accumulation, 10 cm below ground surface.	S&G IB1b [1]	
T-162	Str. H12-18: from possible midden material mixed with post-abandonment accumulation 10-25 cm below ground surface, above structural features of H12-18 in the area of the central trench.	pre-1560?	S&G IIA1e [1] S&G IIA2a [1]
T-624	Almost certainly displaced from a burial, the bead came from about 30 cm below ground surface in an area with no clearly associated burials; the nearest are B 534 and 536, both juveniles, which lay 1.0 m to the east and slightly south of the point where this bead was recovered.		Kidd IIa59 [1]

**THE TIPU BEAD SAMPLE: CONTEXTS**

Virtually all of the uncertainty that envelops the Lamanai sample does not affect the major portion of the material at Tipu. In contrast with the Lamanai specimens, a minimal number of the Tipu beads comes from midden or structure core contexts (Table 2). The preponderant portion of the sample was associated with burials (Table 3) placed both beneath the nave

floor of the Spanish church (Fig. 3) and also outside the church on the north, west and south sides. The practice of sub-floor burial in the nave is also in evidence in the first church at Lamanai (Pendergast 1986b:4), but only one burial was accompanied by a fragment of probable European metalwork and none was interred with beads. Although the evidence is not absolutely conclusive, the contrast between the Lamanai and Tipu church-burial samples suggests that

**Table 3. Burials with Associated Beads at Tipu.**

Burial No.	Lot No.	Sex and Age	Context	Bead Dates	Variety and Quantity
B 75	T-615	juvenile, 6-8	Bead was found 60 cm below ground surface, above burial, and is assumed to be part of B 75; field notes report 2 inter-linked earrings found in dirt within skull.		S&G IIIA2f [1]
B 95	T-613	female, 25-35	Blue glass bead found with wire at skull; probably part of earring suspended from wire.	post-1580	Kidd IIa40 [1]
B 139	T-510	juvenile, 5-7	Approx. 140+ necklace beads were found in dirt within the skull (Pls. IVA-B). Of these, ca. 139 are glass beads, and 3 are jet. Another jet bead is part of a silver earring at the right ear (Pl. IVC).	ca. 1540-1630, probably post-1575	S&G IIC2e [1] S&G IC1a [3] S&G IC1b [60] S&G IC1c [43] S&G IC1d [11] S&G IC1e [15] S&G IB1i var. [5] Kidd IIa59 [1] Jet var. 1 [2] Jet var. 2 [1] Jet var. 5[1]
B152, 153,154 155,156 159,160	T-619	juveniles, 2-5	Broken jet seed bead; field notes place it with B154, but these burials are mixed and fragmentary as a result of ancient disturbance.		Jet var. 4 [1]
B 244	T-881	juvenile, 4-6	Numerous small beads found in the neck area; total ca. 370.	ca. 1540-1630, probably post-1575	S&G IB1i [228] Kidd IIa*(b) [140] S&G IB1b [2]
B 247	T-883	juveniles, 3-5 and 4-6	B 247 includes 3 mixed and fragmentary individuals of which 2 are juveniles and 1 is undetermined. Six beads (5 complete, 1 fragmented) were recovered, probably associated with the 3-5 year old.	ca. 1540-1630, probably post-1575	S&G IB1e [2] Kidd IIa*(a) [1] Kidd IVa*(b) [1] Kidd IVb*(a) [1] Kidd IVb*(b) [1]
B 344	T-862	juveniles, 3-5 and 9-11	B 344 consists of fragments of 2 juvenile burials aged 3-5 and 9-11; the 2 beads (1 is a fragment ) appear to be associated with the 9-11 year old; a copper needle was also recovered, but could be associated with either individual.	ca. 1560-1575	S&G IIA1e [1] Kidd IIa*(a) [1]



Table 3. Continued.

Burial No.	Lot No.	Sex and Age	Context	Bead Dates	Variety and Quantity
B 361 B 362	T-850	juveniles, 4-6 and 6-8	<p>These burials were adjacent to one another and poorly preserved. Both individuals were buried with glass bead jewelry. The T-850 artifacts could be from either 361 or 362. A silver earring is reported for B 361 in the field notes. T-850 includes 3 copper bells, two of which had glass beads in the suspension hoops, suggesting that one child wore a necklace of glass beads (mostly Nueva Cadiz) from which hung copper bells. T-850 also includes 3 <i>Spondylus</i>-shell beads that may have formed a composite necklace with the glass beads (some Nueva Cadiz beads were found in the neck area of B 362; see T-892). Two small, broken, side-notched points and a broken obsidian blade also came from this lot, but may be from grave fill.</p> <p>Tentatively, based on the field notes, the bright blue and chevron beads are part of B 361, with the Nueva Cadiz beads being part of the necklace of B 362, in which case the copper bells and possibly the shell beads are also associated with B 362.</p>	pre-1575	S&G IA3d [1] S&G IIA1e [15] S&G IVA4a [2]
B 362	T-892	juvenile, 6-8	Beads were found around the skeleton and in the neck region; 1 <i>Spondylus</i> -shell bead was also found with this burial; indications are that the Nueva Cadiz beads of T-850 and possibly the copper bells and all the <i>Spondylus</i> -shell beads are associated with B 362.	ca. 1560-1575	S&G IA1b [1] S&G IIA1e [1] Kidd IIb18 [1]
B 363	T-882	male, 18-22	This was a historic-period burial, but the individual was flexed (Fig. 5), not extended as is the norm, and lay on his right side; he wore a <i>Spondylus</i> -shell armband or bracelet (9 beads) on his lower right arm, and a bracelet of ca.12 Nueva Cadiz Plain and Twisted glass beads on his left wrist (Fig. 8).	pre-1560	S&G IIA2a [7] S&G IIC2b [1] S&G IIIA2a [1] S&G IIIC2c [1] S&G II*** (weathered, unclassifiable) [2]
B 379	T-865	juvenile, 10-12	The beads were found on the right side of the skull; 2 (copper?) rings or earrings were also found in the general vicinity of the skeleton.	ca. 1540-1630, probably post-1575	S&G IB1b [2]

Table 3. Continued.

Burial No.	Lot No.	Sex and Age	Context	Bead Dates	Variety and Quantity
B 397	T-849	juvenile, 6-8	The 97 beads were found in the neck area; a compound gilded pendant (composed of the S&G IIIA1a beads; Fig. 6) was recovered while sifting dirt from the skull.	pre-1560	S&G IIA1e [51] S&G IB1i [19] S&G IB2b [4] S&G IIIA1a [10] S&G VID1c(?) [1] Bone var. 1 [12]
B 417	T-847	probably male, 17-20	The glass bead is not mentioned in the field notes, and was probably found while sifting dirt from within and around the skull; fragments of copper ornaments or fittings were found near a mandible fragment that lay on a clump of dirt resting on the right arm of nearby B 415.	ca. 1575-1630	Kidd IIB18 [1]
B 427	T-891	probably female, 25-35	The 28 beads are not described in the field notes, and were probably recovered while sifting dirt from within and about the skull.	ca. 1575-1630	S&G IB1b [6] S&G IB1e [3] S&G IB1i [3] Kidd IIA7 [2] Kidd IIA*(c) [1] S&G IB2b [2] Kidd IVa(c) [1] Kidd IVa(d) [10]
B 463	T-889	male, 20-30	The bead was found between the knees.	pre-1560	S&G IIA2a [1]
B 479	T-888	juvenile, 12-14	The glass bead came from the right ischium; a tubular <i>Spondylus</i> -shell bead was found in one of the hands.	post-1580	Kidd IIA40 [1]
B 520	T-873	juvenile, 3-5	Two fluted-teardrop jet beads were found (Pl. IIIA, R.2, #1). Fragments of a probable copper earring (Fig. 7) were found on the right side of the head, and it is believed that at least one of the beads formed part of the ornament.		Jet var. 3 [2]
B 533	T-811	juvenile, 5-7	There is no mention of the beads in the field records. However, since this is an infant, the delicate bones and the soil matrix were removed to the lab, and the beads were probably recovered while sifting the soil.		S&G IB1e [86] IB1b var. [33]



**Figure 3.** The church at Tipu, looking northeast, with the altar in the east end. An extensive cemetery is situated on its north, west and south sides (photo by R. Kautz).

either beads were utilized for different purposes at the two sites, or the nature of access to European goods differed in the two communities.

The Tipu beads that derive from structure-core and midden contexts provide limited information regarding possible use. The beads associated with church burials, however, are a significant source of such data; they are from primary contexts and date, at least insofar as their use is concerned, from the middle to latter half of the 16th century and the early 17th century, when relations between Tipu and the Spanish authorities were relatively good. For this reason, the presentation of contextual data for the bulk of the sample focuses on issues quite different from those reviewed at Lamanai. The principal considerations regarding the contexts of the 18 bead-associated Tipu interments, apart from their general locations within the nave, are the sex and age of the individuals. Use of the beads as jewelry is indicated by the location of the specimens relative to the body; e.g., in the skull or neck region, near the ear or in the area of the pelvis where a hand lay. Not all burials are quite so informative because some were affected by later

disturbance that usually resulted from multiple sequent interments in a very restricted space.

All but one of the individuals for whom data were recoverable were interred fully extended on their backs with heads to the west (orientation range:  $254^{\circ}$  to  $290^{\circ}$ ), facing east, with the arms either folded over the stomach or chest (Fig. 4) or extended at the sides; this is the standard Christian burial mode (Graham, Pendergast and Jones 1989:1258). The lone deviation from this pattern occurred in Burial 363, but even though the individual was flexed on the right side in Precolumbian fashion, the burial retained the Christian westward orientation of the head (Fig. 5). (This interesting burial, on the church's north side, was disturbed by a later interment, and is believed to be one of the earlier Christian burials at the site.)

Data on age and sex of the interred individuals were provided by the director of the church burial excavations, Mark Cohen of the State University of New York at Plattsburgh. The ongoing work of Cohen and his collaborators on the Tipu population is contributing extensively to our expanding knowledge of the Conquest experience and its effects on the diet

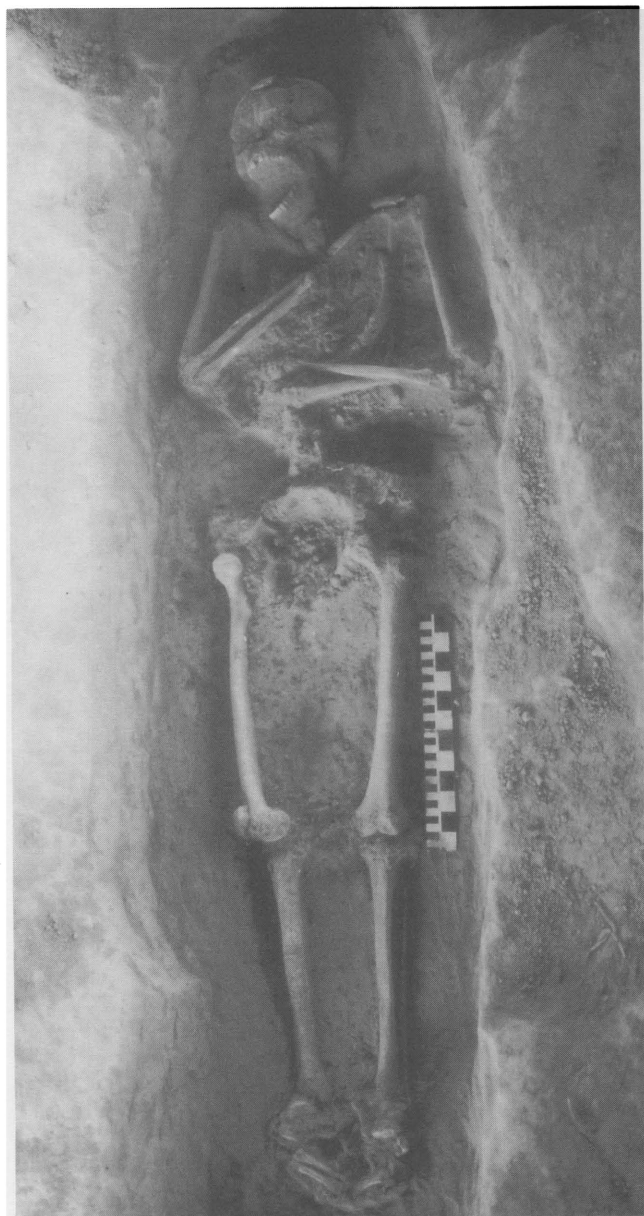

**Figure 4.** Burial 463, an adult male, in the typical Christian burial posture at Tipu (photo by E. Graham).

and health of New World peoples (e.g., Cohen, Bennett and Armstrong 1991; Cohen et al. 1992, 1994, n.d.; Danforth 1989, 1991; Jacobi 1994).

#### **THE TIPU BEAD SAMPLE: CHRONOLOGICAL BRACKETING**

The Tipu collection reflects an occupation from the early 1540s until perhaps the early part of the 17th

century. The site's documentary history has been presented elsewhere both extensively (Jones 1989) and in summary (Graham 1991; Graham, Pendergast and Jones 1989); we provide a brief review here because some of the suggested early and late terminal dates for the beads are based on an architectural sequence that has been tentatively correlated with the documentary evidence.

Although the name "Tipu" does not appear in Spanish records until 1568, evidence regarding the conquest of the region by Melchor and Alonso Pacheco suggests that Tipuans were expected to begin paying tribute as early as 1544 (Jones 1984, 1989:14, 41-44, 51). In subsequent years, the Maya of both Tipu and Lamanai engaged in anti-Spanish rebellions; intensification of such activity in 1567-1568 resulted in a Spanish decision to focus on Tipu and make it a resettlement community, in which rebellious and potentially rebellious Maya from remote villages were placed under firmer Spanish control (Jones 1989:22, 47-53). The more extensive Colonial-period construction and some additions to existing buildings are believed to reflect the Spaniards' investment in the site during this period (Graham, Pendergast and Jones 1989:1256). If this proposed correlation is correct, beads from structures used during the Postclassic to Colonial-period transition (such as H12-6 and portions of H12-8) are most likely to date from 1544 to 1568, whereas those from buildings of entirely Colonial-period construction (H12-13, H12-7 and H12-14) and from additions to structures that already had Colonial components (H12-8) represent the years from 1568 to perhaps the beginning of the 17th century.

In the early 17th century, Maya cooperation with the Spaniards waned and then ceased with the major rebellion of 1638, which drove the Spaniards from Belize. They did not return until 1695, when Tipu became a base for unsuccessful Spanish efforts to draw the recalcitrant Itza Maya of the Peten into the European fold. Military conquest of the Itza in 1697 resulted in Spanish loss of interest in Tipu, although the community continued to exist until its inhabitants were forcibly resettled on the shores of Lake Peten Itza in 1707.

At first glance, Tipu's 163-year Colonial-period history might lead one to expect more beads of 17th-century date than occur in the collection.



**Figure 5.** Atypical Tipu Burial 363 which is flexed on its right side in standard Precolumbian fashion (photo by E. Graham).

However, closer inspection of the community's archaeological and documentary evidence shows that ties were strongest, and Christianization efforts the most effective and best monitored, from the mid-16th century but only through the early years of the 17th century. Dating of the bead types by Smith is largely in accord with the archaeological and documentary record.

The only discordances occur in the cases of beads found in non-burial, non-primary contexts (e.g., beads from redeposited middens used in construction or

recovered from post-abandonment accumulation [Table 2]). Beads from post-abandonment deposits could, of course, have been brought to the surface by roots; if not, they are most likely from the latest Colonial-period occupation at that location (i.e., they were lost at this time) and, therefore, date to the early 17th century. Beads from the redeposited middens could have been lost as early as the 1560s, but acquired even earlier. On the other hand, these middens were not sealed and, hence, could contain material lost much later than the 1560s. Unlike the

Lamanai situation, the midden contexts at Tipu are not primary and, thus, are too equivocal to be very helpful with the bead chronology.

## GLASS BEAD DESCRIPTIONS AND COMPARISONS

The bead sample investigated in this study includes 816 specimens from Tipu and 46 from Lamanai. The bulk of the beads are glass of drawn manufacture. Only two wound glass varieties represented by three specimens are present. Beads of materials other than glass include five jet varieties, one amber variety and one bone variety. A number of the recovered varieties have relatively long temporal ranges, but all appear to relate to the 16th- and 17th-century occupations of the two sites.

The bead descriptions, which are organized according to manufacturing technique, employ the typology developed by Smith and Good (1982)(hereafter S&G) for 16th-century beads from Peru for comparative purposes. Previously unrecorded varieties have been assigned S&G codes and are marked "(new)." The typology developed by Kidd and Kidd (1970)(hereafter Kidd) is also utilized for descriptive purposes and to identify beads not suitable for the S&G system. The Kidds' scheme, though useful for post-A.D.-1560 beads, lacks the precision of the Smith and Good typology for early 16th-century beads and, hence, specific varieties cannot usually be identified. When this is the case, an asterisk (\*) appears in the type code followed by a sequential letter (one letter sequence per type) for ease of reference. A number of beads from both Lamanai and Tipu are highly patinated and not identifiable to the specific variety level in some cases; nevertheless, the types present are easily datable.

Within the broad categories of manufacturing technique, beads are classified by structure. Multilayered beads are described from outer layer to inner, with slashes (/) separating the layers.

The third basis for classification is color. Color names are generally those used in the *Color Harmony Manual* (Container Corporation of America 1958) which is the notation system employed by the Kidds. Beads are categorized as transparent (tsp.) if the perforation is visible when the bead is held up to the light, translucent (tsl.) if light penetrates the bead and

opaque (op.) if it does not. However, in the case of heavily patinated beads and the interior layers of multilayered beads, it was occasionally impossible to determine the diaphaneity.

Beads are further classified on the basis of general shape categories: tubular, spherical, subspherical, barrel shaped, olive shaped, torus ("doughnut") shaped and so forth. Detailed discussions of bead typology can be found in Good (1972), Karklins (1985), Kidd (1979), Smith and Good (1982) and Sprague (1985).

### Drawn Glass Beads

#### *Tubular Beads with Plain Layers*

These beads consist of unaltered tube segments whose shape has not been modified by heat rounding. However, some specimens do exhibit grinding on their ends. There are 13 varieties represented by 134 specimens (two additional Nueva Cadiz Plain beads from Tipu and one from Lamanai were too weathered to classify). Many of these are varieties of Nueva Cadiz Plain and Nueva Cadiz Twisted beads which exhibit one to three layers. Tubular beads with plain layers make up 11.6% of the Tipu collection, but comprise 84.8% of the Lamanai total.

In the descriptions that follow, D = diameter, L = length, W = width and T = thickness. Pl. = color plate, R. = row and # = position in row.

**IA1b (S&G illustration no. 2).** Tubular, oval cross section; tsl. navy blue. This is Kidd variety Ia19.

Tipu: n = 1. D: 2.5-3.0 mm; L: 11.5 mm.  
Lamanai: none present.

**IA3d (new).** tubular, round cross section; op. aqua blue with three compound spiral stripes of tsl. white on op. brick red (Pl. IIC, R.1, #1). Kidd variety Ibb'\*. This is a new variety from a mid-16th-century context, judging by its gravelot association with Nueva Cadiz beads.

Tipu: n = 1. D: 7.0 mm; L: 11.0 mm.  
Lamanai: none present.

**IIA1e (S&G Ill. 37).** Tubular, square cross section (Nueva Cadiz Plain); tsl. navy blue. Kidd variety Ic\*.

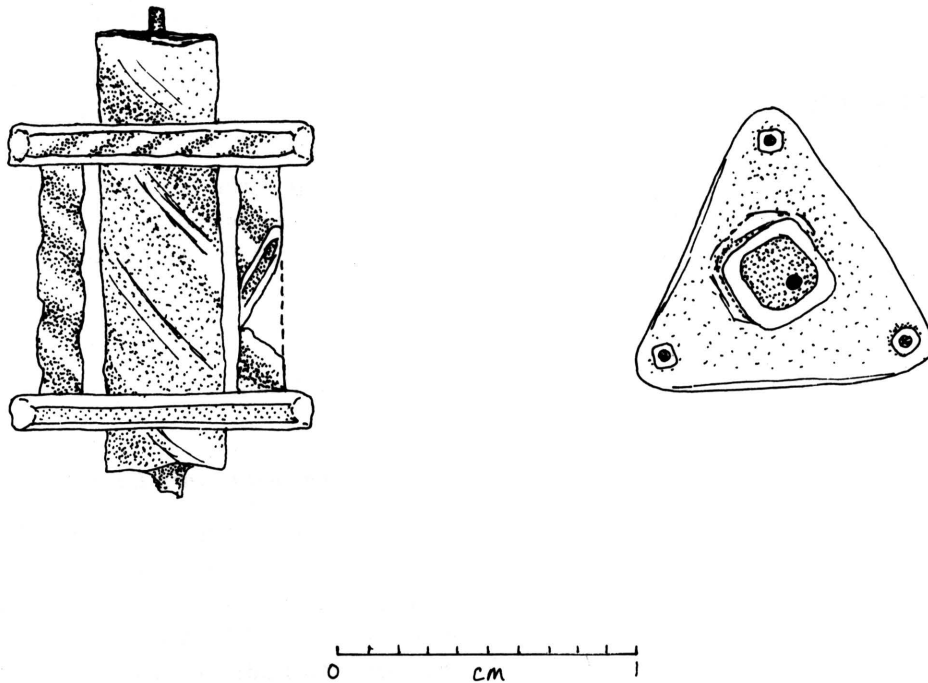

**Figure 6.** An unusual pendant found with Burial 397, a juvenile, at Tipu. The object consists of a large central IIIA1a bead flanked by several similar but smaller specimens set in an unidentified bonding agent (drawing by Julie Barnes-Smith).

The square cross section is rather indistinct on most of the thinner specimens.

Tipu:  $n = 70$ . D: 1.5-3.5 mm; L: 8.0-20.0 mm.

Lamanai:  $n = 4$ . D: 2.0-3.0 mm; L: 7.5-14.0 mm.

**IIA2a (S&G III. 40).** Tubular, square cross section (Nueva Cadiz Plain); tsl. bright blue/ op. white/ tsl. navy blue core that appears black by reflected light (Pl. IIC, R.1, #2; R.3, #1). Kidd variety IIIc\*. Nueva Cadiz beads with a purple core have been reported from the Nueva Cadiz type site (Smith 1983).

Tipu:  $n = 6 + 4$  variants. D: 3.5-6.0 mm; L: 9.0-33.0 mm. One of the variants has a very dark burgundy core that appears black by reflected light. The other three variants have dark purple cores that appear black by reflected light; one of these is the longest of the IIA2a beads. The variants have not been separated into new varieties because their external appearance is the same as the typical IIA2a specimens.

Lamanai:  $n = 6$  definite, 2 possible (eroded) + 2 variants. D: 3.0-6.0 mm; L: 17.0-44.0 mm. The variants have very dark burgundy cores that appear black by reflected light.

**IIA2b variant.** Tubular, square cross section (Nueva Cadiz Plain); tsl. bright blue/ op. white/ tsl. pale blue core (Pl. IIC, R.1, #3). A slight variant of S&G variety IIA2b (Ill. 41), with a pale blue rather than colorless core. Like Kidd variety IIIc1.

It appears that the inner layers of 16th-century beads were quite variable, and were probably made of whatever glass was available. Slight variations in core color are, therefore, not seen as important criteria for the identification of new varieties.

Tipu: none present.

Lamanai:  $n = 2$ . D: 3.5, 5.0 mm; L: 8.0, 24.0 mm.

**IIC2b (S&G III. 51).** Tubular, square cross section (Nueva Cadiz Plain); tsl. bright blue/ op. white/ tsl.

pale blue core (Pl. IIC, R.1, #4). The corners of one end have been ground to produce facets. Like Kidd variety IIIc1, but with the addition of facets.

Tipu: n = 1. D: 3.5 mm; L: 35.0 mm.

Lamanai: none present.

**IIC2e (S&G III. 54).** Tubular, square cross section (Nueva Cadiz Plain); tsl. navy blue/ op. white/ tsl. navy blue core (Pl. IIC, R.2, #1). The corners have been ground to produce facets. Fairbanks (1967) would have considered this a Peru Corner Faceted bead, but this designation has generally passed out of usage. Kidd variety IIIc\*, but with ground end facets.

Tipu: n = 1. D: 4.0 mm; L: 5.0 mm.

Lamanai: none present.

**IIIA1a (S&G III. 57).** Tubular, twisted, square cross section (Nueva Cadiz Twisted); tsp. navy blue (Pl. IIC, R.2, #2). Kidd variety Ic'\*

Tipu: n = 10. D: 1.4-3.5 mm; L: 7.8-14.0 mm. These specimens comprise an unusual pendant (Fig. 6; Pl. IIIA, R.2, #2) found with Burial 397, a juvenile. The object consists of a large central IIIA1a bead flanked by nine similar but smaller specimens set in an unidentified bonding agent. The additional beads produce a triangular cage effect around the central bead. At the corners of the ornament are impressions of spherical objects, perhaps tiny pearls, now missing. A wire passes through the perforation of the central bead. Remnants of gold leaf on the object suggest that part or all of it was originally gilded.

Lamanai: n = 1. D: 4.0 mm; L: 15.5 mm. This appears to be variety IIIA1a, but is highly weathered and has a relatively thin wall, suggesting that it is the core of a badly eroded multilayered bead.

**IIIA2a (S&G III. 58).** Tubular, twisted, square cross section (Nueva Cadiz Twisted); tsl. bright blue/ op. white/ tsl.-op. navy blue core (Pl. IIC, R.2, #3). Kidd variety IIIc'\*

Tipu: n = 2. D: 4.0-5.0 mm; L: 12.0-30.0 mm.

Lamanai: n = 9 definite, 3 probable (eroded) + 1 variant (the latter has a dark burgundy core that appears black). D: 4.5-5.0 mm; L: 7.0-45.5 mm.

**IIIA2b (S&G III. 59).** Tubular, twisted, square cross section (Nueva Cadiz Twisted); tsl. bright blue/ thin

op. white/ tsp. light blue core (Pl. IIC, R.2, #4). Kidd variety IIIc'\*

Tipu: none present.

Lamanai: n = 6 definite and 1 probable (eroded). D: 4.0-8.0 mm; L: 9.0-47.0 mm.

**IIIA2f (new).** Tubular, twisted, square cross section (Nueva Cadiz Twisted); tsl. bright blue/ op. white/ tsp. purple core (Pl. IIC, R.2, #5). This is a slight variant of variety IIIA2a, with a purple rather than a blue core. A Nueva Cadiz Plain bead with this layering is reported from the Tatham Mound in Florida (Mitchem and Leader 1988:45), a site perhaps visited by Hernando de Soto in 1539. Kidd variety IIIc'\*

Tipu: n = 1. D: 4.5 mm; L: 21.0 mm.

Lamanai: none present.

**IIC2a (S&G III. 67).** Tubular, twisted, square cross section (Nueva Cadiz Twisted); tsl. bright blue/ thin op. white/ tsl.-op. navy blue core. The bead has facets ground on the corners of both ends. Kidd variety IIIc'\*, but with ground end facets.

Tipu: none present.

Lamanai: n = 1 + 1 variant. D: 5.0, 10.0 mm; L: 18.0, 28.0 mm. The variant has a deep burgundy core that appears black by reflected light.

**IIC2c (S&G III. 69).** Tubular, twisted, square cross section (Nueva Cadiz Twisted); tsl. bright blue/ op. white/ tsp. pale blue core (Pl. IIC, R.3, #2). Kidd variety IIIc'\*

Tipu: n = 1 fragment with facets on one end only. D: 6.0 mm; L: 10.5 mm.

Lamanai: none present.

Nueva Cadiz beads were first described from the Nueva Cadiz site in Venezuela, occupied from 1515 to 1541 (Deagan 1987; Fairbanks 1967; Goggin n.d.; Smith and Good 1982). At present no temporal distinction is made between Nueva Cadiz Plain and Twisted beads; the two occur together at a number of sites. The many varieties identified by color combinations, together with end faceting, also do not seem to be temporally diagnostic at our present state of knowledge. Beads of twisted glass and blue cut glass were in use during the conquest of Mexico, 1517-1521 (Bernal Díaz del Castillo, *in* Smith and Good 1982:4). The



reference is clearly to Nueva Cadiz Twisted beads, and the mention of cut glass suggests that some were also faceted. Nueva Cadiz beads are common in Peru, conquered in the 1530s, and are found on sites in the southeastern United States which are believed to have been visited by Spanish explorers in the 1520s to 1540s. They have been found in a tomb at Kilómetro 1, Apartado, Antioquia, Colombia (Bray 1978:106); at Valentim, Brazil (Meggers and Evans 1957: 59); with a burial at Changuina, Costa Rica (Stone 1966), and elsewhere in that country (Hartman 1901). Although Deagan (1987:163) states that they are absent at St. Augustine in Florida, Santa Elena in South Carolina, and Bayaha, Haiti, a recent find at the Fountain of Youth Park site in St. Augustine (Florida State Museum, 8SJ31 Fs#1177) suggests that they may occasionally be found in contexts that postdate 1565. Prior to this find, general opinion based on archaeological evidence was that Nueva Cadiz beads usually predate 1560 (Smith 1983, 1987; Smith and Good 1982), or 1550 (Deagan 1987:163).

#### ***Tubular Chevron Beads with Unfaceted Ends***

Two varieties of tubular chevron beads with 5-7 layers are in the collection. These have layers molded to show a star pattern in cross section. They comprise only 0.2% of the Tipu bead collection and 4.3% of the Lamanai total.

**IVA4a (S&G III. 73).** Tubular chevron bead with five layers: tsp. light gray (colorless)/op. white with tsl. navy blue stripes set in the grooves/ op. brick red/ op. white/ tsp. very pale blue or colorless core (Pl. IIC, R.3, #3). The ends are heat rounded. Like Kidd variety IIIk3.

Tipu: n = 2. D: 4.0, 4.5 mm; L: 7.5, 9.0 mm. One specimen is badly patinated, and the identification of the core's color is tentative.

Lamanai: none present.

**IVA4c (new).** Tubular chevron bead with seven layers: tsl. navy blue/ op. white/ op. brick red/ op. white/ tsl. pale blue/ op. white/ tsp. pale blue(?) core (Pl. IIC, R.3, #4). The high points of the rays of the second layer show through as white stripes. One specimen is severely patinated and the identification of the colors of the three innermost layers is tentative. The second example is even more patinated. The ends are eroded.

Similar to S&G variety IVA4a, but with more layers; Kidd variety IIIk\*.

Tipu: none present.

Lamanai: n = 2. D: 8.5 mm; L: 15.0, 21.0 mm.

Varieties of tubular chevron beads similar to the above two are known from many early-to mid-16th-century contexts. They have been found at Nueva Cadiz (Smith 1983); Puerto Real, Haiti (1503-1578)(Ewen 1991); in a tomb at Kilómetro 1, Apartado, Antioquia, Colombia (Bray 1978:106); the Treasure Island Canal Zone 10 site (slide in Florida State Museum); Cajamarquilla, Peru (Peabody Museum, Harvard, 46-77-30/6048; slide courtesy of Jeffrey Brain); and various other sites in Peru and Colombia (Smith and Good 1982). What may be the latest well-dated specimen, ca. 1570, was found at the Fountain of Youth Park site in St. Augustine (Deagan 1987:114, 166).

#### ***Tubular Chevron Beads with Faceted Ends***

The following chevron bead variety was produced by grinding tubular specimens into subspherical or olive-shaped forms. Definite flat facets are present on the ends.

**IVC2e (S&G III. 83).** Irregular-subspherical to olive-shaped chevron beads with faceted ends; seven layers: tsl. navy blue/ op. white/ op. brick red/ op. white/ tsl. navy blue/ op. white/ tsp. blue core (Pl. IIC, R.3, #5; IIIB, R.1, #1). Kidd variety IIIk\*.

Tipu: none present.

Lamanai: n = 2. D: 4.0-7.5 mm; L: 6.0-6.5 mm.

The IVC2e chevron bead has been reported from the Tatham Mound, Florida (Mitchem and Leader 1988). The many varieties of faceted chevron beads generally appear to be of similar date: approximately 1500-1590, with infrequent occurrences until perhaps 1600 (Smith 1983, 1987; Smith and Good 1982); the dates assigned by Deagan (1987:172) are 1500-1580. The beads have been reported from Fountain of Youth Park and Fort Center (Florida State Museum collections examined by Smith); Weeki Wachee and Ruth Smith Mounds (Mitchem et al. 1985); Philip Mound, Seven Oaks, San Marcos de Apalachee and St. Marks Lighthouse in Florida; Parkin Mound in Arkansas; Bear Point, Alabama; Kent Mound, Georgia (Smith and

Good 1982); Poarch Farm, Georgia (private collection located by James B. Langford); Puerto Real, Haiti, in a 1540-1578 context (Florida State Museum collections examined by Smith; *see* Ewen 1991); Nueva Cadiz, Venezuela (Smith 1983:158); Treasure Island Canal Zone 10 site (slide in Florida State Museum); in a tomb at Kilómetro 1, Apartado, Antioquia, Colombia (Bray 1978:106); Costa Rica (Hartman 1901:Plate 60); and Picaca Cemetery, Brazil (Meggers and Evans 1957:50-51). Many other sites in the Southeast from Florida to Missouri have produced faceted chevron beads, but their specific varieties have not been determined. The majority of the finds in the Southeast are from aboriginal sites probably visited by Hernando de Soto between 1539 and 1543.

On Spanish-Colonial sites, small faceted seven-layer chevron beads were replaced by heat-rounded, generally spherical chevron beads with five layers sometime around 1580-1590 (Deagan 1987; Smith 1983). They, thus, appear to have remained in use perhaps as much as a quarter century longer than Nueva Cadiz beads.

#### ***Heat-Rounded Beads other than Seed Beads***

Drawn beads whose shapes were imparted by heating and agitating them during the production process usually postdate Nueva Cadiz beads. There seems to have been a shift from the long tubular beads of the mid-16th century to short subspherical beads that were popular from the late 16th through the 17th century at Spanish-Colonial sites (Smith 1983). Some heat-rounded beads have been observed in Peruvian collections with Nueva Cadiz beads, but specific grave provenience was not available. Heat-rounded beads identified in Peru as probably predating 1560 have been assigned variety numbers by Smith and Good (1982). Later heat-rounded beads have been classified using the Kidd system when possible.

Non-seed bead heat-rounded beads were rare at Lamanai (2.2%), but made up 17.9% of the Tipu bead collection.

**IB1b (S&G III. 10).** Subspherical to oblate spheroidal; tsp. navy blue (Pls. IIC, R.4, #1; IIIB, R.1, #2). Kidd variety Ila55. A common bead from 1575-1670; reported from the Tatham Mound in Florida, with a date near 1540 (Mitchem and Leader 1988).

Tipu: n = 11. D: 2.5-7.0 mm; L: 2.5-7.0 mm.

Lamanai: none present.

**IB1b variant.** Subspherical; tsp. pale navy blue (patinated)(Pl. IIIB, R.1, #3). A pale form of Kidd variety Ila55.

Tipu: n = 33. D: 4.0 mm; L: 3.5 mm.

Lamanai: none present.

**IB4f (new).** Olive-shaped; tsl. navy blue/ thin op. white/ tsl. navy blue core (Pl. IIC, R.4, #2). The exterior is decorated with 8 opaque white stripes. Like Kidd variety IVb35, but olive shaped. Previously unreported, although it is similar to several identified varieties. A similar, unprovenience specimen from Peru has only six stripes (Smith: notes). Almost certainly a mid-16th-century bead.

Tipu: none present.

Lamanai: n = 1. D: 5.0 mm; L: 11.0 mm.

**Kidd Ila40.** Subspherical; op. bright blue (Pl. IIC, R.4, #3). Numerous tiny bubbles.

Bright blue/turquoise blue beads appeared around 1575, and quickly became one of the more common beads in the trade. They remained in common use until well into the 19th century. Smith (1983:150) notes that the earlier specimens tend to be subspherical or spherical, whereas 18th-century beads tend to be more barrel shaped. Smith (1983) attributes the variety to the period from ca. 1575 to the 18th century, and Deagan (1987) suggests a range of 1575-1720, based on the sample of sites chosen for her analysis.

Tipu: n = 2. D: 6.5, 7.0 mm; L: 6.0 mm.

Lamanai: none present.

**Kidd Ila\*(a).** Subspherical; tsp. bright blue (Pl. IIC, R.4, #4). One example was recovered by Deagan from the Fountain of Youth Park site (8SJ31), established in 1565.

Tipu: n = 1. D: 6.0 mm; L: 5.5 mm.

Lamanai: none present.

**IB1e (S&G III. 13).** Subspherical to ovate spheroidal; tsp. dark green (Pl. IIC, R.4, #5). Like Kidd variety Ila28.

Small, green, heat-rounded beads were found in collections of 16th-century Peruvian beads by Smith and Good (1982), and have been reported from the Tatham Mound in Florida (Mitchem and Leader 1988). They

are quite common during the period ca. 1575-1670, and have been found at the Terrapin Creek site (ca. 1590-1610), Bradford Ferry site (ca. 1600-1630) and Milner Village site (ca. 1630-1670) in Alabama (Smith 1987, 1992; Smith et al. 1993).

Tipu: n = 91. D: 3.0-7.0 mm; L: 3.0-7.0 mm.  
Lamanai: none present.

**Kidd IVa\*(a).** Torus-shaped; small, with four(?) layers: tsp. light gray (colorless)/ tsl. copen blue/ op. white(?)/ tsl. copen blue core (Pl. IIIB, R.1, #4).

Tipu: n = 1. D: 3.5 mm; L: 2.0 mm.  
Lamanai: none present.

**Kidd IVa\*(b).** Subspherical; tsp. light gray (colorless)/ op. brick red/ tsl. burgundy core that appears black by reflected light (Pl. IIIB, R.1, #5). A slight variant has a purple core.

This is an unusual variant of the common Cornaline d'Aleppo bead which usually has a green core (see Kidd IVa\*[c] below). Deagan (1987) dates the common Cornaline d'Aleppo varieties to the period 1575-1800. The present variety, probably of late 16th-century date, has not been previously identified.

Tipu: n = 1 + 1 variant. D: 3.0-4.0 mm; L: 2.0-3.5 mm.

Lamanai: none present.

**Kidd IVa\*(c).** Subspherical; tsp. light gray (colorless)/ op. brick red/ tsl. yellowish green core (Pl. IIIB, R.1, #6). This is the common Cornaline d'Aleppo variety which Deagan (1987) dates to the 1575-1800 period.

Tipu: n = 1. D: 3.2 mm; L: 2.0 mm.  
Lamanai: none present.

**Kidd IIB18.** Subspherical to spherical; tsp. light gray (colorless) with 11-13 op. white stripes (Pl. IIC, R.4, #6). The white stripes rest on a colorless core and are covered by a thick layer of colorless glass so that the stripes are deeply embedded in the bead. This is popularly called a "gooseberry" bead.

Gooseberry beads appear in early- to mid-16th-century contexts, but as long olive-shaped forms (Smith and Good 1982:III. 27). The subspherical variety probably appeared about 1575, when other subspherical heat-rounded beads appeared in quantity. This variety is common well into the 18th century, but

a change to a barrel shape usually defines the late form.

Tipu: n = 2. D: 4.5, 5.5 mm; L: 4.0, 5.5 mm.  
Lamanai: none present.

**Kidd IVb\*(a).** Subspherical; tsp. navy blue/ op. white/ tsp. navy blue/ op. white/ incomplete tsp. navy blue core (Pl. IIIB, R.1, #7). The exterior is decorated with three op. brick red and three op. white alternating stripes. A similar bead, with fewer layers and only two red and two white alternating stripes, was found at the aboriginal Terrapin Creek site in Alabama, with an estimated date of 1575-1600 (Smith 1992).

Tipu: n = 1. D: 5.0 mm; L: 4.5 mm.  
Lamanai: none present.

**Kidd IVb\*(b).** Ovate spheroidal; tsp. navy blue/ op. white/ tsp. navy blue (Pl. IIIB, R.1, #8). Two op. brick red stripes adorn the exterior. A similar bead with additional white stripes was uncovered at the Terrapin Creek site (Smith 1987).

Tipu: n = 1. D: 4.0 mm; L: 5.5 mm.  
Lamanai: none present.

#### **Faceted Seed Beads**

Most of these small beads exhibit several random ground facets that were applied after the beads had been heat rounded (Pl. IVA). However, on variety IC1\*, the facets form a definite pattern. Faceted seed beads were only present at Tipu where they comprised 16.2% of the bead collection.

**IC1a (S&G III. 32).** Faceted subspherical; small; tsp. navy blue (Pl. IIIB, R.1, #9). Kidd variety IIf\* in the expanded version (Karklins 1985:94).

Tipu: n = 3. D: 3.0 mm; L: 4.0 mm.  
Lamanai: none present.

**IC1b (new).** As above, but tsp. purple (Pl. IIIB, R.2, #1).

Tipu: n = 60. D: 2.9-3.5 mm; L: 3.0-3.8 mm.  
Lamanai: none present.

**IC1c (new).** As above, but tsp. cerulean blue (Pl. IIIB, R.2, #2).

Tipu: n = 43. D: 3.0-3.5 mm; L: 3.0 mm.  
Lamanai: none present.

**IC1d (new).** As above, but tsp. amber (Pl. IIIB, R.2, #3).

Tipu: n = 11. D: 2.5 mm; L: 2.0 mm.

Lamanai: none present.

**IC1e (new).** Faceted ovate spheroidal; tsp. purple covered with a thick chalky patina (Pl. IIIB, R.2, #4). While there is variation in the pattern of the facets, the optimal form seems to be four triangular to pentagonal facets around either end.

Tipu: n = 15. D: 3.0-3.5 mm; L: 3.8-4.0 mm.

Lamanai: none present.

Only one navy blue faceted subspherical seed bead has been identified by Smith and Good (1982) in collections of hundreds of early Peruvian beads. One example was recovered from the Ruth Smith Mound in Florida with Nueva Cadiz beads, with a possible date of ca. 1539 (Mitchem et al. 1985:209). Beads of these varieties are relatively numerous at the Bradford Ferry site (ca. 1600-1630) in Alabama (Smith 1987, 1992).

The name Cedar Bluff Small Blue Decahedral was applied to these beads in the 1960s by workers at Mound State Monument, Alabama, but was never published. The beads appear to be good markers of the 1540-1630 period. They are directly associated with a Nueva Cadiz bead in Burial 139 at Tipu and this, plus their almost total absence from mid-16th-century Peruvian collections, suggests use in the late 16th century, perhaps ca. 1560-1570.

### **Seed Beads**

Seed beads are small heat-rounded glass beads often used for embroidery, although they also functioned as necklace beads. They are usually of little value for comparative purposes and, for that reason, are treated in summary form here. Seed beads are generally unusual in collections of 16th-century Peruvian beads, but their scarcity may be a function of recovery techniques. Available data suggest their appearance in the late 16th century. Most seed beads are torus-shaped, but some are more barrel-shaped or spherical.

Seed beads were encountered only at Tipu. They were relatively common, comprising 51% of the bead collection.

**IB1i (S&G III. 17).** Tsp. navy blue (Pl. IIIB, R.2, #5). A number of specimens are severely eroded and most of their color has leached out (Pl. IIIB, R.2, #6). Kidd variety IIA56. These beads were rare in the hundreds of looted 16th-century beads from Peru studied by Smith and Good (1982).

Tipu: n = 250. D: 2.5-3.5 mm; L: 1.0-3.0 mm.

Lamanai: none present.

**IB1i variant.** Tsp. pale navy blue (Pl. IIIB, R.2, #7). A pale form of Kidd variety IIA56.

Tipu: n = 5. D: 2.5 mm; L: 2.0 mm.

Lamanai: none present.

**Kidd IIA59.** Tsp. purple (Pl. IIIB, R.2, #8).

Tipu: n = 1 + 1 fragment. D: 3.0 mm; L: 1.5 mm.

Lamanai: none present.

**Kidd IIA\*(b).** Torus-shaped; tsp. amber (Pl. IIIB, R.2, #9).

Tipu: n = 140. D: 2.5 mm; L: 1.5 mm.

Lamanai: none present.

**Kidd IIA7.** Op. black (Pl. IIIB, R.3, #1).

Tipu: n = 2. D: 3.0 mm; L: 1.0 mm.

Lamanai: none present.

**Kidd IIA\*(c).** Tsp. light gray (colorless)(Pl. IIIB, R.3, #2). The glass contains several longitudinal bubbles which give the impression of stripes.

Tipu: n = 1. D: 3.0 mm; L: 1.5 mm.

Lamanai: none present.

**IB2b (S&G III. 21).** Tsl. navy blue/ op. white core (Pl. IIIB, R.3, #3). Kidd variety IVA\*. This bead has been identified in 16th-century collections from Peru, and is present at the post-1565 Fountain of Youth Park site in St. Augustine.

Tipu: n = 6. D: 2.0-2.5 mm; L: 1.5-2.0 mm.

Lamanai: none present.

**Kidd IVA\*(d).** Thick tsp. light gray (colorless)/ op. white core (Pl. IIIB, R.3, #4).

Tipu: n = 10. D: 3.0 mm; L: 1.5 mm.

Lamanai: none present.

## Wound Glass Beads

### *Small Seed Beads*

A single wound seed bead was uncovered at Tipu. It was formed by winding a single filament of glass around a mandrel at least once. The ends of the filament do not abut but overlap so that the bead presently consists of a glass loop. One end of the filament is flattened against the other and probably represents an original bead end. The other end of the filament is round-sectioned and broken, suggesting that the bead may originally have consisted of several revolutions of the filament.

**VID1c(?)**. Torus-shaped at present; tsp.-tsl. amber(?) (Pl. IIIB, R.3, #5). The glass is patinated and partially decolorized, making it difficult to determine the original color. Small wound beads have been recovered from early 16th-century sites in Peru (Smith and Good 1982:37-38), as well as from the purported site of Columbus' landing on San Salvador in the Bahamas (Brill and Hoffman 1987).

Tipu: n = 1. D: 2.8 mm; L: 1.6 mm.

Lamanai: none present.

### *Large Subspherical Beads*

Lamanai produced one variety, possibly from a rosary. This variety was produced by repeatedly winding a glass filament around a mandrel until the desired size was achieved.

**Kidd W1b11**. Subspherical; op. robin's egg blue (Pl. IIC, R.4, #7). These beads have a long temporal range, but they do occur at least as early as the mid-17th century. A rosary composed mostly of identically sized specimens was encountered in the cemetery of Sainte-Marie among the Hurons, a Jesuit mission which operated near what is now Midland, Ontario, from 1639-1649 (Karklins 1995), and it is likely that the Lamanai specimens date to approximately the same time period. However, the possibility remains that they may represent the so-called "Padre Beads" which are believed to have been made in China (Sprague 1992), and were common in the southwestern United States during the late 19th century.

Tipu: none present.

Lamanai: n = 2. D: 8.0, 9.0 mm; L: 7.0, 7.5 mm.

## BEADS OF OTHER MATERIALS

Full descriptions of the five varieties listed below are presented in a discussion of jet and amber sources represented in the Tipu collection (Lambert et al. 1994).

### **Jet Beads**

Five varieties of jet beads were recovered. Carbon-13 nuclear magnetic resonance spectroscopic analysis of samples taken from varieties 2, 3, 4 and 5 revealed a jet spectrum consistent with a Spanish origin (Lambert et al. 1994).

**Variety 1**. Rectangular- to square-based pyramidal beads with a perforation in each of two opposing corners (Pl. IIIA, R.1, #1-2; IVB). Each hole consists of two parallel-sided segments which were drilled into the sides near the corners at roughly right angles to each other.

This jet variety, generally considered to be a rosary bead, is the most common at Spanish-Colonial sites, with a date range from about 1650 to 1800 (Deagan 1987:183).

Tipu: n = 2. W: 5.0, 6.0 mm; L: 6.5, 7.0 mm; T: 4.5, 5.0 mm.

Lamanai: none present.

**Variety 2**. Tapering faceted bead; pentagonal cross section (Pls. IIIA, R.1, #3; IVB). The perforation is slightly hourglass shaped.

Tipu: n = 1 fragment. D: 6.5 mm (existing); L: 5.5 mm (existing).

Lamanai: none present.

**Variety 3**. Fluted (tetralobate) teardrop-shaped bead (IIIA, R.2, #1). The perforation is hourglass-shaped. Two specimens were recovered, but one subsequently fragmented as the result of desiccation. Parts of what appears to have been a copper earring (Fig. 7) were found in association and it is believed that at least one of the jet beads formed a part of it. A likely configuration is depicted in a 16th-century painting repro-

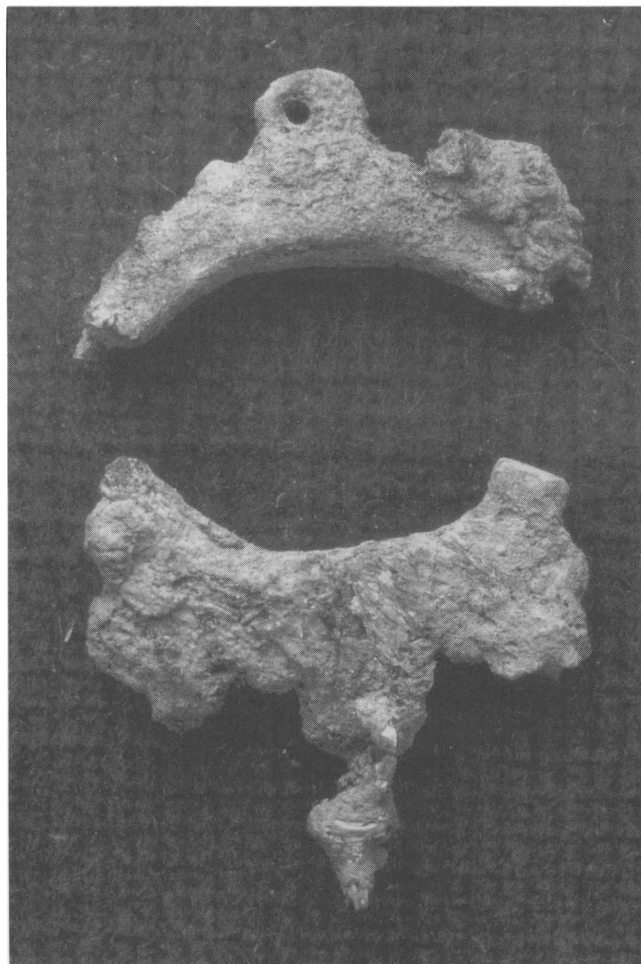

**Figure 7.** Remnants of a copper earring found with Burial 520. It is believed that one of the fluted teardrop-shaped beads was originally suspended in the central opening (photo by B. Boyle).

duced in South, Skowronek and Johnson (1988:159, Fig. 94, bottom right).

Tipu: n = 2. D(max.): 10.0 mm; L: 13.5 mm.

Lamanai: none present.

**Variety 4.** Spherical seed bead.

Tipu: n = 1 fragment. D: 4.0 mm; L: ca. 4.0 mm.

Lamanai: none present.

**Variety 5.** Faceted subspherical. This specimen formed part of an earring (Pl. IVC), but disintegrated after recovery. The bead had a series of trapezoidal facets around the middle as well as either end. The perforation was hourglass-shaped (Pl. IVD).

Tipu: n = 1. D: 4.0 mm; L: ca. 4.0 mm.

Lamanai: none present.

**Amber Bead**

A single amber bead was excavated at Tipu. NMR spectroscopic analysis indicates that the amber is clearly of Baltic origin (Lambert et al. 1994).

**Variety 1.** Subspherical bead (Pls. IIIA, R.2, #3; IVD). Reddish amber with a weathered cortex. The perforation is parallel sided.

Tipu: n = 1. D: 15.0 mm; L: 9.0 mm.

Lamanai: none present.

**Bone**

A number of small bone seed beads were uncovered at Tipu. These appear to have been lathe-turned as evidenced by a slight lip around the perforation on some specimens (this has been obliterated by grinding in a number of instances), a feature noted on other bone beads that were definitely lathe-turned (Karklins 1995). While local manufacture cannot be ruled out entirely, it is likelier that the beads were manufactured in Europe.

**Variety 1.** Subspherical to barrel-shaped (Pl. IIIB, R.3, #6). The holes are parallel sided.

Tipu: n = 8. D: 2.3-3.0 mm; L: 2.5 mm.

Lamanai: none present.

**DISCUSSION**

**The Lamanai Collection**

The collection of beads from Lamanai primarily reflects a middle 16th-century occupation. The assemblage consists of several varieties of Nueva Cadiz Plain, Nueva Cadiz Twisted, faceted chevron and tubular chevron beads. The faceted chevrons are known to have been in use virtually throughout the century, whereas the Nueva Cadiz beads were typically out of style by mid century.

Any provenience that contains Nueva Cadiz beads probably predates 1550 or 1560, whereas one that only contains chevron beads may date as late as 1570-1580,

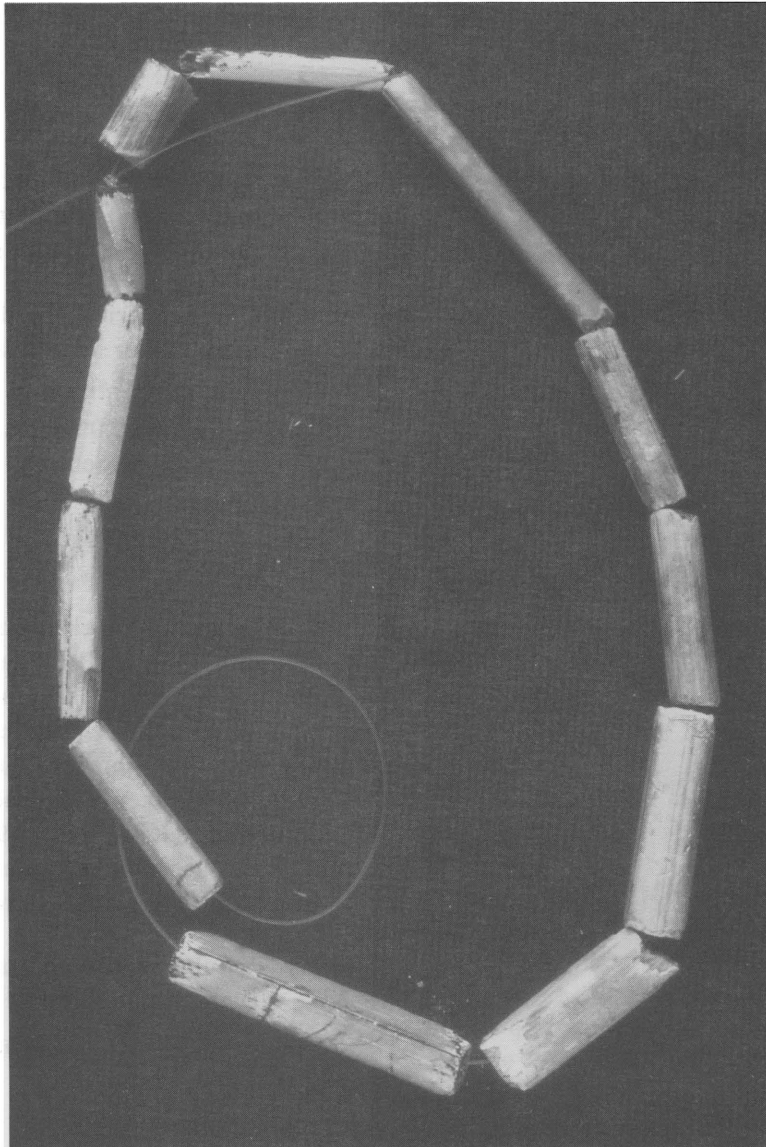

**Figure 8.** The bracelet of Nueva Cadiz Plain and Twisted beads found on the left wrist of Tipu Burial 363 (conjectural stringing)(photo by B. Boyle).

but could just as easily be pre-1550. At Lamanai, chevron beads were always found in deposits with Nueva Cadiz beads, so the sample in its entirety appears to date from before about 1550-1560 on typological grounds. The probability that Spaniards were periodically present at the site for at least a half century after 1544 suggests that supplies of beads would have continued to be available and, hence, that new styles could have been introduced in the years following 1570-1580. The absence of late 16th and early 17th-century beads seems at first glance to raise

the possibility that the contexts investigated at Lamanai ceased to be occupied by 1580, but archaeological evidence shows instead that early beads are very likely to have remained in use until about 1641. The small quantity of beads may indicate that the entire lot was imported to Lamanai over a comparatively short period; it is possible that limitations in quantity combined with early cessation of bead importation to lend additional importance to the beads, and to ensure their retention in use over three quarters of a century or more.

## The Tipu Collection

The Tipu assemblage of mid-16th-century beads consists of several varieties of Nueva Cadiz Plain, Nueva Cadiz Twisted and tubular chevron beads. Large Nueva Cadiz beads were typically out of style by the middle of the century, but smaller beads of this type may have remained in use until about 1575 or possibly even 1600, because they are found in association with several varieties of heat-rounded beads at Native American sites (Smith 1983). The Tipu collection further solidifies this association through the co-occurrence with Burial 344 of a heat-rounded blue bead and a S&G IIA1e Nueva Cadiz bead. Presumably, an early to mid-16th-century assemblage that consisted of long tubular Nueva Cadiz beads gave way to a transitional assemblage of small Nueva Cadiz varieties and subspherical heat-rounded beads about 1575, with a subsequent disappearance of the Nueva Cadiz varieties that left only the more-or-less spherical heat-rounded beads by perhaps the 1580s or 1590s.

Any primary context (i.e., the burials, since the middens at Tipu are redeposited) that contains large Nueva Cadiz or long tubular chevron beads probably predates 1550 or 1560, although tubular chevron beads have been found in post-1565 context at St. Augustine. Beads may, of course, have been available to the inhabitants of Tipu prior to the first Spanish appearance on the site about 1544, and documentary evidence suggests that importation of new styles could have continued after 1570-1580.

Structures probably occupied prior to 1560 include H12-8 and H12-6. The fact that several burials in the church were accompanied by Nueva Cadiz beads suggests that the church, or at least the Christianization process, was in operation before 1560. The tubular chevron bead probably associated with Burial 361 indicates a date before 1570, and may identify the burial as among the earlier ones in the structure.

Lots that contain only the small Nueva Cadiz IIA1e beads could be as late as ca. 1580, but clearly could be as early as those with large Nueva Cadiz or tubular chevron beads. The association of a heat-rounded bead with a small Nueva Cadiz bead in the gravelot of Burial 344 suggests a date of about 1575 for the interment.

Lots that contain subspherical or spherical beads of various shades of blue and green probably postdate 1560, and could extend well into the 17th century. However, given the scarcity of beads and the absence of certain marker types (such as Kidd flush-eye types IIg and IVg), it appears quite likely that most or all of the contexts are of late 16th-century date. The fact that the new bead types that appear in the ca. 1590-1630 period are not present at Tipu may indicate any of several things: that only early burials were accompanied by beads; that the church was little used in the early 17th century; that importation of beads to the site ceased at some point prior to 1590; or, if priests and their catechizing efforts were the primary vehicle of bead transport to Tipu, that priests ceased to visit the community on a regular basis after about 1590. Burials 95 and 479, both accompanied by bright blue heat-rounded beads that probably postdate 1580, appear to be among the later interments in the church.

The dates postulated for the bead-associated burials listed in Table 3 are based on the assumption that the beads were not retained in use for any appreciable time after their arrival at Tipu. The assumption is obviously not directly testable but, if the beads were used by the persons with whom they were buried, consideration of style may indicate reasonably close links between bead age and interment date. Beads that are listed as dating as late as 1630 could be of even later 17th-century date, but both the site's documented history and the general scarcity of beads among the church burials argue for a cutoff date well before mid century.

Beads can also be used in a very limited fashion to shed light on periods of structure use. For example, it appears fairly likely on various grounds that the use of the superstructure of Structure H12-7 continued beyond that of Structure H12-6; the fact that H12-6 contained a large Nueva Cadiz bead (pre-1550 or 1560) whereas H12-7 yielded a bead of probable 1575-1630 date lends weak support to the archaeologically based suggestion.

Apart from potential support for structure histories, the beads are a very substantial basis for the interpretation of burial and related practices in the contact-period years at Tipu. Although one-third (6) of the bead-associated burials are those of adults, it is clear on simple numerical grounds that beads played



a particularly important role in child burials. This recognition is greatly strengthened when quantities and positions of the beads are considered; four of the six adults were accompanied by single beads, and only one (Burial 363; see Table 3) possessed a quantity of beads equal to that of some of the juveniles. The two major concentrations of beads were associated with children aged four to six years and five to seven years, near the lower end of the probable age range of one to 12 years for the entire group. Five of the nine children were interred with necklaces (Table 3), and none can be shown to have been clothed in garments adorned with beads; in contrast, the lone adult with an appreciable quantity of beads appears to have been buried in a bead-decorated loincloth or other lower-body garment.

The predominance of associations between children and beads is quite likely to mirror the special affinity that priests are reported to have felt for the young (Mendieta 1945, Tomo II:64, Tomo III:72-73), as well as the importance of children as interpreters for the Spanish and as singers, sacristans and assistants in the Mass (Peñalosa 1969:69, 70). In the case of the adult burials, the presence of beads and the differences in quantity may reflect status, even though the quantities of beads are minuscule in all cases but one. None of the adults was of advanced years; hence, it is possible that even here we may be seeing, especially in the case of Burial 363, persons who played liturgical roles earlier in life.

### Summary

The history of bead use at Lamanai and Tipu is obviously incomplete at this stage, if for no other reason than the need for further work at both sites. We hope to extend investigation of the contact-period site center at Tipu, and excavation of a second cemetery at Lamanai is also a goal for the future. These two efforts are highly likely to augment our knowledge of both the range of the beads that were imported and the full extent and significance of bead use in the two communities. The Lamanai work, in particular, has the potential for revising the present picture of burial/bead association rather drastically. Appreciation of the beads as part of an assemblage of European imports can be gained in part from existing discussions (Graham 1991:327-328; Graham,

Pendergast and Jones 1989:1258; Pendergast 1991:347-351; Pendergast and Graham 1993:344-351), but will remain limited until detailed reporting is complete. It is clear at this stage, however, that the inter-site differences apparent in the bead collections are a reflection of major differences in other areas of European material impact on native culture, just as in a sense they reflect the communities' largely divergent courses in pre-contact times. The contrasts between the two sites tell us, in the area of bead studies as in all aspects of contact-period research, that it is exceedingly dangerous to erect generalizations regarding Maya/Spanish interaction on the presently available data foundation. As the first collections from Central America to be analyzed, the Lamanai and Tipu beads are unquestionably instructive. However, we shall not know the full range of questions to be asked, let alone the answers, until excavations have shed light on a good many more 16th- and 17th-century communities.

### ACKNOWLEDGEMENTS

Excavations at Lamanai were supported by Royal Ontario Museum research funds and grants from the Social Sciences and Humanities Research Council of Canada and the Richard Ivey Foundation of London, Ontario. The Tipu excavations have been funded by SSHRCC, the National Geographic Society and the Royal Ontario Museum. The church-burial excavations and skeletal studies were supported by a National Science Foundation Grant to Mark Cohen. Aspects of the burial mapping and integration of locational and skeletal data were made possible by a grant from York University.

The late Charles Fairbanks, together with Jerald Milanich and Kathleen Deagan, provided access to many collections of beads from Florida and the Caribbean that allowed useful comparisons. Mary Elizabeth Good and Jeffrey Mitchem have proved most willing to share their knowledge of early Spanish beads, and other individuals too numerous to mention have aided Smith's quest for knowledge on early beads.

### REFERENCES CITED

- Bray, W.  
1978 *The Gold of El Dorado*. Times Newspapers Limited, London.

**Brill, R.H. and C.A. Hoffman**

- 1987 Some Glass Beads Excavated on San Salvador Island in the Bahamas. *Annales du 10<sup>e</sup> Congrès de l'Association Internationale pour l'Histoire du Verre*:373-398.

**Cohen, M.N., C.W. Armstrong, M.E. Danforth, K.P. Jacobi and K.A. O'Connor**

- 1992 Health Indicators on the Fringe of Spanish Influence: The Maya of Tipu (abstract). *American Journal of Physical Anthropology*, Suppl. 14:60-61.

**Cohen, M.N., S.L. Bennett and C.W. Armstrong**

- 1989 Health and Genetic Relationships in a Colonial Mayan Population. Submitted to the National Science Foundation, Grant No. 85-06785. Manuscript on file. State University of New York, Plattsburg, New York.
- 1991 Interaction of Classes of Health Indicators at Tipu (abstract). *American Journal of Physical Anthropology*, Suppl. 12:59.

**Cohen, M.N., K.A. O'Connor, M.E. Danforth, K.P. Jacobi and C.W. Armstrong**

- 1994 Health and Death at Tipu. In *In the Wake of Contact: Biological Responses to Conquest*, edited by C.S. Larsen and G.R. Milner, pp. 121-133. Wiley-Liss, New York.
- n.d. The Osteology and Archaeology of Tipu. In *Bones of the Ancestors: Recent Contributions in Maya Osteology*, edited by S.L. Whittington and D.M. Reed. Smithsonian Press, Washington, D.C. (in press).

**Container Corporation of America**

- 1958 *Color Harmony Manual*, 4th ed. Chicago.

**Danforth, M.E.**

- 1989 A Comparison of Childhood Health Patterns in the Late Classic and Colonial Maya Using Enamel Microdefects. Unpublished Ph.D. dissertation. Department of Anthropology, Indiana University, Bloomington. University Microfilms International, Ann Arbor.
- 1991 Childhood Health Patterns at Tipu: Evidence from Harris Lines (abstract). *American Journal of Physical Anthropology*, Suppl. 12:65.

**Deagan, K.**

- 1987 *Artifacts of the Spanish Colonies of Florida and the Caribbean, 1500-1800. Volume 1: Ceramics, Glassware, and Beads*. Smithsonian Institution Press, Washington, D.C.

**Ewen, C.R.**

- 1991 *From Spaniard to Creole: The Archaeology of Cultural Formation at Puerto Real, Haiti*. University of Alabama Press, Tuscaloosa.

**Fairbanks, C.H.**

- 1967 Early Spanish Colonial Beads. *Conference on Historic Site Archaeology Papers* 2(1):3-21.

**Goggin, J.M.**

- n.d. An Introduction to Spanish Trade Beads and Pendants of the 16th and 17th centuries. Manuscript on file. Peabody Museum, Harvard University, Cambridge, Mass.

**Good, M.E.**

- 1972 Guebert Site: An 18th Century, Historic Kaskaskia Indian Village in Randolph County, Illinois. *Central States Archaeological Societies Memoir* 2.

**Graham, E.**

- 1991 Archaeological Insights into Colonial Period Maya Life at Tipu, Belize. In *The Spanish Borderlands in Pan-American Perspective*, edited by D.H. Thomas, pp. 319-335. Columbian Consequences, vol. 3. Smithsonian Institution Press, Washington, D.C.

**Graham, E. and S. Bennett**

- 1989 The 1986-1987 Excavations at Negroman-Tipu, Belize. *Mexicon* 11:114-117.

**Graham, E., G.D. Jones and R.R. Kautz**

- 1985 Archaeology and Ethnohistory on a Spanish Colonial Frontier: An Interim Report on the Macal-Tipu Project in Western Belize. In *The Lowland Maya Postclassic*, edited by A.F. Chase and P.M. Rice, pp. 206-214. University of Texas Press, Austin.

**Graham, E., D.M. Pendergast and G.D. Jones**

- 1989 On the Fringes of Conquest: Maya-Spanish Contact in Colonial Belize. *Science* 246:1254-1259.

**Hartman, C.V.**

- 1901 *Archaeological Researches in Costa Rica*. The Royal Ethnographic Museum in Stockholm. Ivar Haeggstroms Bokryckeri A.B., Stockholm.

**Jacobi, K.P.**

- 1994 An Analysis of Genetic Structuring in a Colonial Maya Cemetery, Tipu, Belize, Using Dental Morphology and Metrics (abstract). *American Journal of Physical Anthropology*, Suppl. 18: 114.

**Jones, G.D.**

- 1984 Maya-Spanish Relations in Sixteenth Century Belize. *Belcast Journal of Belizean Affairs* 1(1):28-40.
- 1989 *Maya Resistance to Spanish Rule: Time and History on a Colonial Frontier*. University of New Mexico Press, Albuquerque.

**Karklins, K.**

- 1985 *Glass Beads: The Levin Catalogue of Mid-19th Century Beads; A Sample Book of 19th Century Venetian Beads; Guide to the Description and Classification of Glass Beads*. Parks Canada, Studies in Archaeology, Architecture and History, Ottawa, Ontario.
- 1995 A Study of the Beads from Sainte-Marie among the Hurons, the Heron Site and the Bruneau/Casselman site. In *Before and Beyond Sainte-Marie: 1987-1990 Excavations at the Sainte-Marie among the Hurons Site Complex (circa 1200-1990)*, by J. Tummon and W.B. Gray, pp. 161-184. Copetown Press, Dundas, Ontario.

**Kidd, K.E.**

- 1979 Glass Bead-Making from the Middle Ages to the Early 19th Century. *History and Archaeology* 30.

**Kidd, K.E. and M.A. Kidd**

- 1970 A Classification System for Glass Beads for the Use of Field Archaeologists. *Canadian Historic Sites: Occasional Papers in Archaeology and History* 1:45-89.

**Lambert, J.B., E. Graham, M.T. Smith and J.S. Frye**

- 1994 Amber and Jet from Tipu, Belize. *Ancient Mesoamerica* 5:55-60.

**López de Cogolludo, D.**

- 1971 *Los Tres Siglos de la Dominación Española en Yucatán, o sea Historia de esta Provincia* (facsimile of 2nd edition, Campeche-Merida 1842-1845). Akademische Druck und Verlagsanstalt, Graz.

**Meggers, B. and C. Evans**

- 1957 Archaeological Investigations at the Mouth of the Amazon. *Bureau of American Ethnology, Bulletin* 167.

**Mendieta, G. de**

- 1945 *Historia Eclesiástica Indiana*. 4 vols. Editorial Salvador Chavez Hayhoe, Mexico City.

**Mitchem, J.M. and J.M. Leader**

- 1988 Early Sixteenth Century Beads from the Tatham Mound, Citrus County, Florida: Data and

Interpretations. *Florida Anthropologist* 41(1):42-60.

**Mitchem, J.M., M.T. Smith, A. Goodyear and R. Allen**

- 1985 Early Spanish Contact on the Florida Gulf Coast: The Weeki Wachee and Ruth Smith Mounds. In "Indians, Colonists, and Slaves: Essays in Memory of Charles H. Fairbanks," edited by K. Johnson, J. Leader and R. Wilson, pp. 179-220. *Florida Journal of Anthropology, Special Publication* 4.

**Peñalosa, J.A.**

- 1969 *La Práctica Religiosa en México: Siglo XVI*. Editorial Juan, Mexico City.

**Pendergast, D.M.**

- 1981 Lamanai, Belize: Summary of Excavation Results, 1974-1980. *Journal of Field Archaeology* 8:29-53.
- 1982 The 19th-Century Sugar Mill at Indian Church, Belize. *IA* 8(1):57-66.
- 1986a Stability through Change: Lamanai, Belize, from the Ninth to the Seventeenth Century. In *Late Lowland Maya Civilization: Classic to Postclassic*, edited by J.A. Sabloff and E.W. Andrews V, pp. 223-249. University of New Mexico Press, Albuquerque.
- 1986b Under Spanish Rule: The Final Chapter in Lamanai's Maya History. *Belcast Journal of Belizean Affairs* 3(1-2):1-7.
- 1990 Up from the Dust: The Central Lowlands Postclassic as seen from Lamanai and Marco Gonzalez, Belize. In *Vision and Revision in Maya Studies*, edited by F.S. Clancy and P.D. Harrison, pp. 169-177. University of New Mexico Press, Albuquerque.
- 1991 The Southern Maya Lowlands Contact Experience: The View from Lamanai, Belize. In *The Spanish Borderlands in Pan-American Perspective*, edited by D.H. Thomas, pp. 337-354. Columbian Consequences, vol. 3. Smithsonian Institution Press, Washington, D.C.
- 1993 Worlds in Collision: The Maya/Spanish Encounter in Sixteenth and Seventeenth Century Belize. In "The Meeting of Two Worlds: Europe and the Americas, 1492-1650," edited by W. Bray, pp. 105-143. *Proceedings of the British Academy* 81.

**Pendergast, D.M. and E. Graham**

- 1993 La Mezcla de Arqueología y Ethnohistoria: El Estudio del Período Hispánico en los Sitios de

Tipu y Lamanai, Belice. In *Perspectivas Antropológicas en el Mundo Maya*, edited by M.J. Iglesias Ponce de León and F. Ligorred Perramon, pp. 331-353. Sociedad Española de Estudios Mayas y Instituto de Cooperación Iberoamericana, Madrid.

**Smith, M.T.**

- 1983 Chronology from Glass Beads: The Spanish Period in the Southeast, 1513-1670. In "Proceedings of the 1982 Glass Trade Bead Conference," edited by C.F. Hayes III, pp. 147-158. *Rochester Museum and Science Center, Research Records* 16.
- 1987 *Archaeology of Aboriginal Culture Change in the Interior Southeast: Depopulation during the Early Historic Period*. University of Florida Press, Gainesville.
- 1992 Glass Beads in the Spanish Trade: The View from the Interior Southeast with Comments on Central American Assemblages of the Sixteenth Century. Paper presented at The Bead Trade in the Americas conference, Santa Fe, New Mexico.

**Smith, M.T. and M.E. Good**

- 1982 *Early Sixteenth Century Glass Beads in the Spanish Colonial Trade*. Cottonlandia Museum Publications, Greenwood, Mississippi.

**Smith, M.T., V. Knight, J. Smith and K. Turner**

- 1993 The Milner Village: A Mid-seventeenth Century Site near Gadsden, Alabama. In "Archaeological Survey and Excavations in the Coosa River Valley, Alabama," edited by V.J. Knight, pp. 49-61. *Alabama Museum of Natural History Bulletin* 15.

**South, S., R.K. Skowronek and R.E. Johnson**

- 1988 Spanish Artifacts from Santa Elena. *Occasional Papers of the South Carolina Institute of Archaeology and Anthropology, Anthropological Studies* 7.

**Sprague, R.**

- 1985 Glass Trade Beads: A Progress Report. *Historical Archaeology* 19(2):87-105.
- 1992 The Chinese Bead Trade. Paper presented at The Bead Trade in the Americas conference, Santa Fe, New Mexico.

**Stone, D.**

- 1966 *Introduction to the Archaeology of Costa Rica*. Museo Nacional, San José, Costa Rica.

**van Oss, A.**

- 1986 *Catholic Colonialism: A Parish History of Guatemala, 1524-1821*. Cambridge University Press, Cambridge.

**Villagutierre Soto-Mayor, J. de**

- 1983 *History of the Conquest of the Province of the Itza*. Labyrinthos, Culver City, California.

Marvin T. Smith  
Sociology, Anthropology and  
Criminal Justice  
Valdosta State University  
Valdosta, Georgia 31698

Elizabeth Graham  
Department of Anthropology  
York University  
4700 Keele Street  
North York, Ontario M3J 1P3

David M. Pendergast  
Department of New World  
Archaeology  
Royal Ontario Museum  
100 Queen's Park  
Toronto, Ontario M5S 2C6

**Plate II C.** *Belize:* Larger glass bead varieties from Lamanai and Tipu. **R.1:** 1, IA3d; 2, IIA2a; 3, IIA2b; 4, IIC2b. **R.2:** 1, IIC2e; 2, IIIA1a; 3, IIIA2a; 4, IIIA2b; 5, IIIA2f. **R.3:** 1, IIA2a; 2, IIIC2c; 3, IVA4a; 4, IVA4c; 5, IVC2e. **R.4:** 1, IB1b; 2, IB4f; 3, Kidd IIA40; 4, Kidd IIA\*(a); 5, IB1e; 6, Kidd IIB18; 7, Kidd WIB11 (centimeter scale) (photo by B. Boyle).

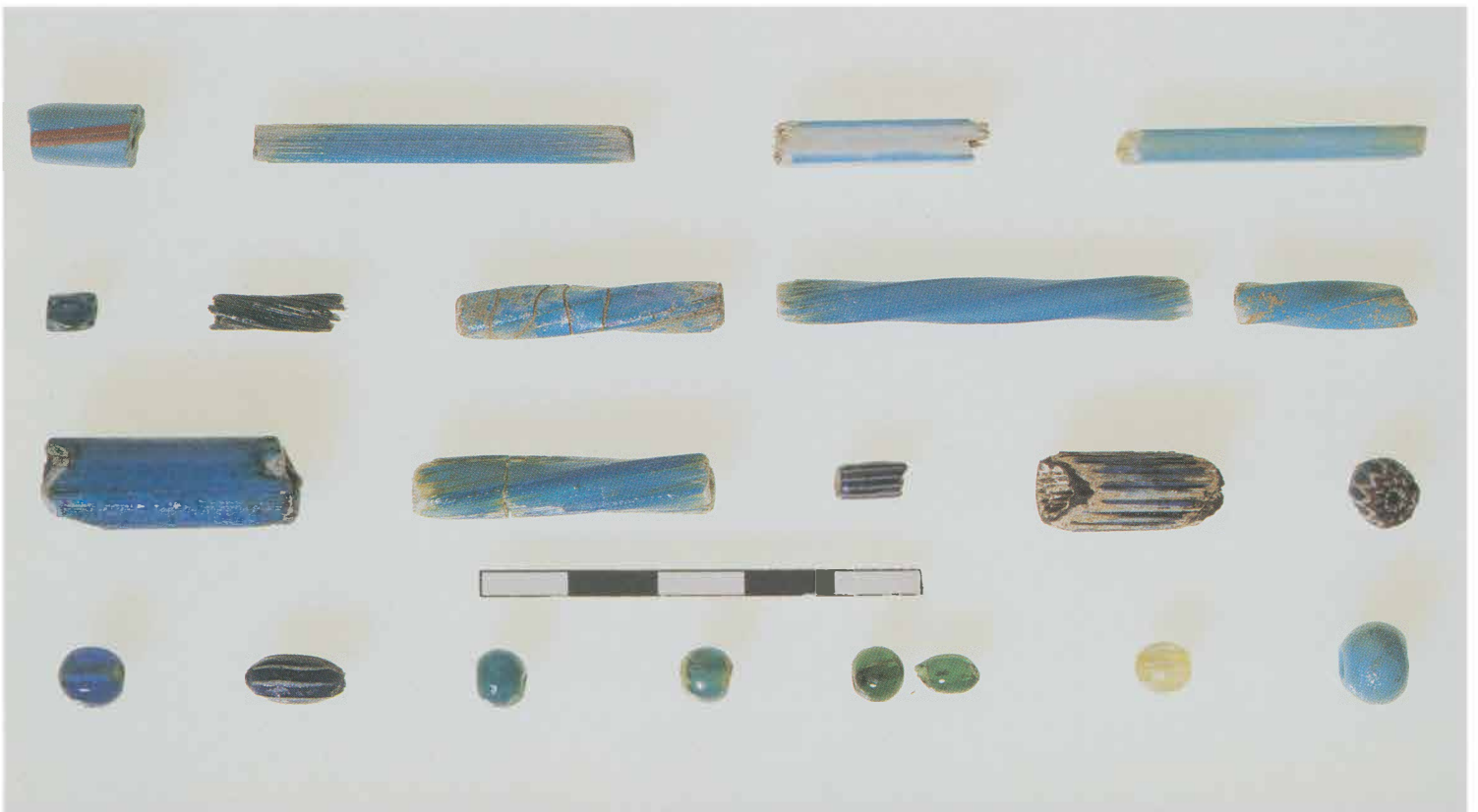



**Plate IIIA.** *Belize:* Beads of jet and amber and a glass-bead pendant from Tipu. **R.1:** 1-2, jet variety 1; 3, jet variety 2. **R.2:** 1, jet variety 3; 2, glass-bead pendant; 3, amber variety 1 (centimeter scale)(photo by B. Boyle).

**Plate IIIB.** *Belize:* Smaller glass and bone bead varieties from Lamanai and Tipu. **R.1:** 1, IVC2e; 2, IB1b; 3, IB1b variant; 4, Kidd IVa\*(a); 5, Kidd IVa\*(b); 6, Kidd IVa\*(c); 7, Kidd IVb\*(a); 8, Kidd IVb\*(b); 9, IC1a. **R.2:** 1, IC1b; 2, IC1c; 3, IC1d; 4, IC1e; 5-6, IB1i; 7, IB1i variant; 8, Kidd IIa59; 9, Kidd IIa\*(b). **R.3:** 1, Kidd IIa7; 2, Kidd IIa\*(c); 3, IB2b; 4, Kidd IVa\*(d); 5, VID1c(?); 6, bone variety 1 (centimeter scale)(photo by B. Boyle).

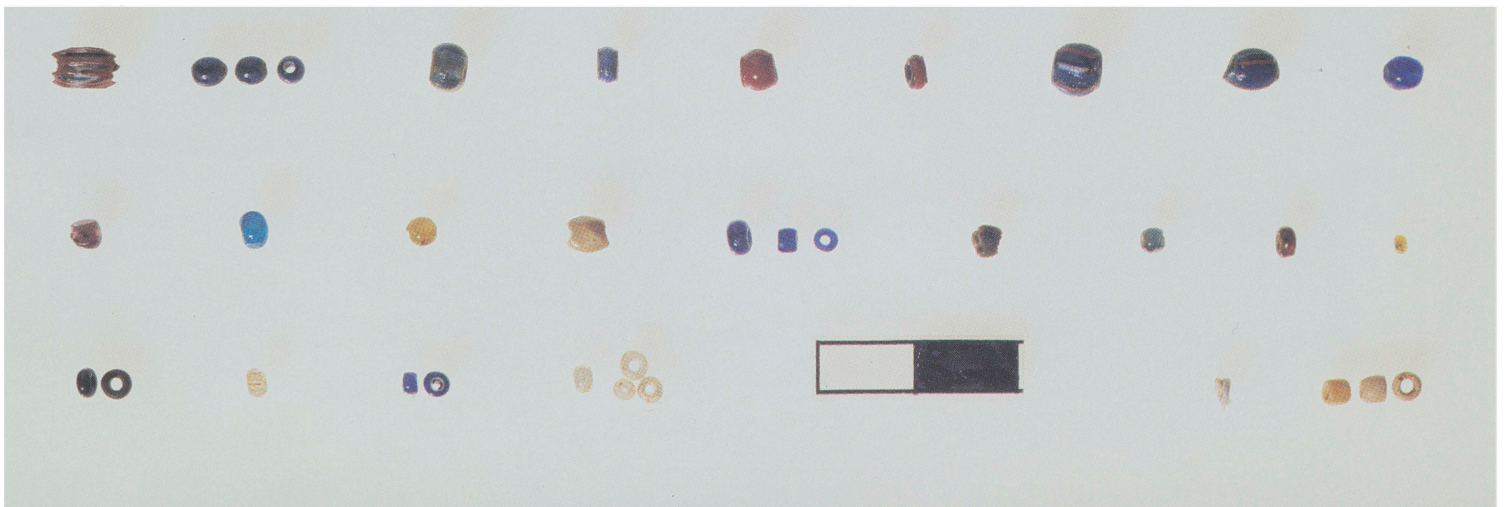



**Plate IVA.** *Belize:* Several varieties of faceted seed beads (D: 3.0-3.5 mm); Tipu Burial 139 (photos by B. Boyle).

**Plate IVC.** *Belize:* Silver earring with a faceted jet bead (variety 5) as its principal component; Tipu Burial 139.



**Plate IVB.** *Belize:* Jet bead varieties 1 and 2 which form part of Burial 139's necklace (conjectural stringing).

**Plate IVD.** *Belize:* The amber bead and the split variety 5 jet bead with its hourglass-shaped perforation (Tipu).

