

Syracuse University

SURFACE

Theses - ALL

5-15-2015

Discrimination of age, sex, and individual identity using the upcall of the North Atlantic right whale (*Eubalaena glacialis*)

Jessica McCordic
Syracuse University

Follow this and additional works at: <https://surface.syr.edu/thesis>



Part of the [Life Sciences Commons](#)

Recommended Citation

McCordic, Jessica, "Discrimination of age, sex, and individual identity using the upcall of the North Atlantic right whale (*Eubalaena glacialis*)" (2015). *Theses - ALL*. 106.
<https://surface.syr.edu/thesis/106>

This is brought to you for free and open access by SURFACE. It has been accepted for inclusion in Theses - ALL by an authorized administrator of SURFACE. For more information, please contact surface@syr.edu.

ABSTRACT

According to the source-filter theory proposed for human speech, physical attributes of the mammalian vocal production mechanism combine independently to result in individually distinctive vocalizations. In the case of stereotyped calls with all individuals producing a similar frequency contour, formants resulting from the shape and size of the vocal tract may be more likely to contain individually distinctive information than the fundamental frequency resulting from the vibrating source. However, the formant structure resulting from such filtering has been historically undervalued in the majority of studies addressing individual distinctiveness in non-human species. The upcall of the North Atlantic right whale (*Eubalaena glacialis*) is characterized as a stereotyped contact call, and visual inspection of upcall spectrograms confirms presence of a robust formant structure. Here I present results testing age, sex, and individual distinctiveness of upcalls recorded from archival, suction cup mounted tags (Dtags). Multiple measurements were made using the fundamental frequency contour, formant structure, and amplitude of the upcalls. These three variable groupings were then tested alone and in combination with other groupings to assign upcalls to age classes based on reproductive maturity, age classes based on size, sex, and individual whales. To compare multiple classification methods, I used both discriminant function analysis and a classification and regression tree to classify calls to appropriate groups. In all analyses, the percentage of calls correctly assigned to the correct group—age, sex, individual—was significantly higher than chance levels. These results represent the first quantitative analysis of individual distinctiveness in mysticete whales and provide a baseline for further development of acoustic detection techniques that could be used to noninvasively track movements of whales across multiple habitats.

**Discrimination of age, sex, and individual identity using the upcall of the
North Atlantic right whale (*Eubalaena glacialis*)**

By
Jessica Annalisa Maverique McCordic
B.A. College of the Atlantic, 2012

THESIS

Submitted in partial fulfillment of the requirements for the
degree of Master of Science in Biology

Syracuse University
May 2015

Copyright © Jessica Annalisa Maverique McCordic 2015

All rights reserved

ACKNOWLEDGMENTS

Dr. Susan Parks deserves utmost recognition for the countless meetings, suggestions, and edits that brought this project from a spark of an idea to the document presented here. With her guidance, I have learned how to become a better person and a better scientist.

I cannot express enough my gratitude to my family, especially my mom, for always being there for me through my entire academic career from pre-kindergarten through graduate school.

I thank my friends, colleagues, and fellow graduate students. They have been the ‘first responders’ to any and all thesis hiccups, as well as the first to remind me to celebrate my successes. In the Parks Lab, Dana Cusano, Leanna Matthews, and Hannah Blair always listened when I puzzled through any uncertainties, especially when I need to draw things out on the whiteboard. Luka Negoita and Elisabeth Bodnaruk have been supportive friends from the beginning and have always been willing to help me talk through my ideas. George Clarke has given me great perspective and seemingly endless encouragement throughout my journey in graduate school. I am grateful to the continued support from my undergraduate family, including but certainly not limited to Dale Quinby, Dr. Sean Todd, Jackie Bort, Michelle Klein, Sara Golaski, Lindsey Nielsen, Christopher Spagnoli, and Rachel Guttmacher. These and others in the COA community have remained a buoying force despite separation of hundreds or thousands of miles.

Finally, I would like to acknowledge all of the field teams that contributed to this dataset. It is no small feat to tag a right whale, and I truly appreciate all of the efforts over the years. Funding agencies for all tags include the following: ONR, NAVFAC Atlantic Fleet, NOAA Fisheries Service, NMFS, IFAW, Massachusetts Division of Marine Fisheries, Massachusetts Environmental Trust, Cooperative Institute for Climate and Ocean Research, Duke University.

TABLE OF CONTENTS

INTRODUCTION.....	1
IDENTITY SIGNALING	1
SOURCE-FILTER HYPOTHESIS AND ITS APPLICATIONS TO NON-HUMAN SYSTEMS	3
STUDY SYSTEM: THE NORTH ATLANTIC RIGHT WHALE (<i>EUBALAENA GLACIALIS</i>)	8
<i>Habitat Usage and Distribution</i>	8
<i>Social System</i>	9
<i>Acoustic Behavior</i>	11
HYPOTHESIS.....	12
METHODS	14
DATA COLLECTION	14
<i>Archival Tags</i>	14
DETERMINING AGE AND SEX.....	15
CALL DETECTION AND ACOUSTIC MEASUREMENTS	16
<i>Time-frequency measurements</i>	18
<i>Formant measurements</i>	18
<i>Amplitude measurements</i>	19
STATISTICAL ANALYSIS	24
<i>Principal Components Analysis</i>	24
<i>Discriminant Function Analysis</i>	25
<i>Classification and Regression Trees</i>	27
RESULTS	28
PRINCIPAL COMPONENTS ANALYSIS.....	28
DISCRIMINANT FUNCTION ANALYSIS.....	31
CLASSIFICATION AND REGRESSION TREES	33
DISCUSSION	38
SUMMARY OF RESULTS	38
IMPROVEMENTS AND FUTURE WORK.....	41
IMPLICATIONS FOR MONITORING	45
APPENDIX A: ADDITIONAL TABLES.....	47
APPENDIX B: ADDITIONAL FIGURES.....	69
LITERATURE CITED	79
VITA.....	88

LIST OF ILLUSTRATIVE MATERIALS

Figure 1: Spectrograms representing the major calls within the North Atlantic right whale repertoire	13
Figure 2: Spectrogram showing time-frequency measurements of an upcall in Raven Pro 1.5.	20
Figure 3: Formant measurements from Praat spectrogram	21
Figure 4: Amplitude measurements from waveform in Raven Pro 1.5	22
Figure 5: Scatterplot matrix of first three principal component scores of the PCA using time-frequency and amplitude variables	30
Figure 6: Canonical discriminant scores for first two discriminant functions using all variables to discriminate among individuals	35
Figure 7: Classification tree using all variables to classify calls to individuals	37
Table 1: Summary of data collection, including all Dtag records	15
Table 2: Tag records used in analysis	17
Table 3: Explanation of acoustic measurements	23
Table 4: Percent variance explained by all principal components and first three principal components when analysis was completed for different variable groupings	31
Table 5: Percent correct classification results from stepwise DFA	32
Table 6: Classification results from CART analysis	36
Appendix A: Additional Tables	47 – 68
Appendix B: Additional Figures	69 – 78

INTRODUCTION

Identity Signaling

Each animal communication system involves the same key components: a signaler generates a signal, sends their signal through an environmental medium, the receiver perceives the signal, and the receiver responds by making a decision based on information contained in the signal (Bradbury & Vehrencamp, 2011). The receiver's response depends on the type and complexity of information that it can extract from the signal. A receiver must be able to filter signals from the noise of the environment. To increase reliability of signal perception for effective communication, one of the necessary components of signal evolution involves ritualized stereotypy (Bradbury & Vehrencamp, 2011). The broadest form of stereotypy allows receivers to reliably associate a particular signal with a conspecific. Within a species, there can also be signals which communicate membership within a group—e.g., sex (Ryan, 1990), kin group (Rendall et al., 1996), foraging group (Boughman, 1997)—adding information that may be beneficial to the receiver to make the appropriate response. Often signals simultaneously encode multiple types of information, such as male advertisement signals which indicate both sex and quality within a single signal (e.g., roaring red deer, *Cervus elaphus* (Clutton-Brock & Albon, 1979)).

The most specific form of stereotypy provides a signal of individual identity. Components of signals that encode individual identity cues will not necessarily be correlated with fitness and should be distinguishable from signals which only discriminate among more general categories such as age class or sex (Dale et al., 2001). Identity signaling occurs when the signaler produces a signal containing cues that exhibit little intra-individual variation while

maintaining a level of inter-individual variation such that the cues may be perceived by the receiver and reliably associated with that individual (Bradbury & Vehrencamp, 2011). There are clear benefits and costs to producing individually distinctive signals. Some potential benefits include increased altruism from kin, decreased harassment from territory neighbors, and decreased risk of inbreeding (Tibbetts & Dale, 2007). The costs associated with producing identity signals primarily correspond to the loss of potential cheating opportunities gained by remaining cryptic, as in cheating offspring that receive benefits from non-kin adults (McCulloch et al., 1999; Tibbetts & Dale, 2007).

From a receiver perspective, there may be an energetic cost attributed to the increased cognition required to perceive differences among conspecifics. Species living in large groups typically have larger brains (Dunbar, 1998), and the higher processing power of larger brains in these species (Dávid-Barrett & Dunbar, 2013) likely contributes to both the increased complexity of signals in highly social species and the corresponding ability to perceive any differences in complex signals (e.g., (Freeberg et al., 2012)). Thus, the high metabolic expense of brain tissue relative to other tissue types (Aiello & Wheeler, 1995) may represent an additional cost of identity signaling.

In vertebrates, signal complexity is generally positively correlated with complexity of social system, defined as the number of different types of interactions and individual encounters within the social group (Freeberg et al., 2012; Pollard & Blumstein, 2011), and individually distinctive signals likely follow this pattern with more complex signals used for identity signaling in more complex societies (Blumstein & Armitage, 1997; Pollard & Blumstein, 2011). In terms of information content within a signal, this is a logical conclusion since receivers in more complex social interactions involving repeated interactions with other conspecifics in a

group may benefit from being able to associate multiple types of information with each signaler. To increase the total amount of information within a call, the complexity of the signal itself must increase, typically involving simultaneous manipulation of multiple types of acoustic parameters—e.g., frequency, amplitude, and duration in acoustic signals (Freeberg et al., 2012).

Individually distinctive signals should be present when the benefits of identity signaling outweigh the costs of being distinctive (Johnstone, 1997; Tibbetts & Dale, 2007). This seems to be the case in a variety of signaling modalities throughout animal systems including invertebrates and vertebrates (e.g., wasps (*Polistes fuscatus*) (Tibbetts, 2002), trout (*Oncorhynchus mykiss*) (Johnsson, 2010), golden hamsters (*Mesocricetus auratus*) (Johnston & Bullock, 2001)). In species that rely heavily on acoustic signaling, acoustic individual recognition has similarly been found to mediate crucial social interactions such as competition for mates (Reby et al., 1998), kin recognition (Blumstein & Munos, 2005), and particularly mother-offspring recognition (Charrier et al., 2002; Espmark, 1971; Sebe et al., 2007).

Source-filter theory and its applications to non-human systems

The source-filter theory of vocal production, initially proposed as a model of human vowel sound production, suggests that a vocalization is the result of independent contributions from a vibrating source and a structural filter: vocal folds in the larynx (source) and any airways between the larynx and the end of the vocal tract (filter), respectively (Fant, 1960; Titze, 2000). The vibrating vocal folds create a stable oscillation which in turn can be measured as a glottal wave and visualized as a waveform. The rate of this oscillation determines the fundamental frequency of the vocalization, and this rate is in turn affected by the length and mass of the vocal folds (Fitch & Hauser, 1995). The vocal tract and associated airways then act as a bandpass

filterbank, selectively amplifying and attenuating bands of frequencies to create broad spectral peaks known as formants (Titze, 2000). Within an individual, the relative spacing of the formant frequencies, termed formant dispersion, depends on the length of the vocal tract as well as its shape determined by complex movements of the musculature. Since humans have such complex oral musculature compared to other primates and terrestrial mammals (Fitch, 2000), the position of the lips and tongue for different phonemes can change the length of the vocal tract enough to affect formant frequencies. For example, certain vowel phonemes involving the lengthening of the vocal tract are characterized by having formants close together as in [u: food] while others involve a shortening of the vocal tract and corresponding formant frequencies that are far apart, as in [i: keep] (Titze, 2000). The overall frequencies of the formants for a specific sound, however, are determined by a range of factors including gender and age along with the length of the vocal tract (Titze, 2000), making formants a robust cue to discriminate among individuals producing the same phonemes. To identify speakers using a variety of phonemes, a combination of source-related frequency measurements and filter-related formant measurements provides the most reliable discrimination among individuals (Bachorowski & Owren, 1999).

The source-filter theory was originally proposed for human speech studies but has found application within non-human bioacoustics research. In non-human mammals, Fitch (2000) suggests that the vocal tract is not as flexible as in humans, precluding the existence of the variety of phonemes present in human speech. Therefore, in non-human vocalizations, the location and dispersion of the formants is more directly linked with the shape and length of the vocal tract for all sounds (Fitch, 2000). Similar to humans, longer vocal tracts show formants with lower formant dispersion, and shorter vocal tracts have higher formant dispersion (Taylor & Reby, 2010). Unlike the length of the vocal tract, the mass and length of the vocal folds is less

constrained by morphological factors such as body size and may be more dependent on condition-related aspects such as hormone levels, potentially making the fundamental frequency less useful as a signal of individuality (Charlton et al., 2011; Taylor & Reby, 2010; Tibbetts & Dale, 2007).

Despite the more reliable link between filter-related characteristics and overall physical structure of the animal, source-related characteristics are preferentially used to measure individuality in non-human vocalizations (Taylor & Reby, 2010). Modulation patterns in the fundamental frequency can encode information about the caller's identity, perhaps best evidenced in the signature whistles of bottlenose dolphins (*Tursiops truncatus*) (Caldwell & Caldwell, 1968; Janik & Sayigh, 2013; Sayigh et al., 2007). Apart from such obvious signature contours, other species have shown individually distinctive cues related to source-based components of their vocalizations (Blumstein & Munos, 2005; Charrier et al., 2002; Vannoni & McElligott, 2007). The filter of the vocal tract, however, also provides a measure of acoustic individual distinctiveness resulting from morphological differences among individuals (Bachorowski & Owren, 1999; Lemasson et al., 2008; Reby et al., 2006). The importance of measurable source-related or filter-related cues in an identity signal may reflect differences in vocal anatomy and the relative ability of animals to produce various identity cues (Tibbetts & Dale, 2007).

Additionally, distinctive acoustic cues are expected to be prevalent in socially complex species that rely on acoustic communication. In the marine habitat, sound travels much more efficiently than any other signaling modality available to mammalian taxa (Au & Hastings, 2010; Bradbury & Vehrencamp, 2011). Marine mammals, particularly cetaceans—whales and dolphins—are notably reliant on sound for communication (Tyack & Miller, 2002). There is a

large division within cetaceans between toothed whales and baleen whales—odontocetes and mysticetes, respectively—in terms of vocal anatomy and sound production, which may affect the physiological basis of identity signaling.

Rather than using the larynx, odontocete whales use ‘phonic lips’ located in the nasal passages as an acoustic source (Dormer, 1979; Tyack & Miller, 2002), potentially decoupling any filter-related cues—generally resulting from the shape of the nasal and oral cavities—from physical attributes of the individual. Although the specific contributions of source- and filter-related cues have not been studied in odontocetes, inferences can be made based on characteristics of known identity signals. As mentioned above, bottlenose dolphins produce frequency modulated whistles that are stereotyped within an individual but differ among individuals (Caldwell & Caldwell, 1968; Janik & King, 2013; Janik & Sayigh, 2013). The frequency contours of the whistles thus serve as “signatures” and have even been shown to be used referentially by other individuals (Janik & Sayigh, 2013; King et al., 2014). Some populations of killer whales (*Orcinus orca*) also use frequency contours for identification, but the different contours are used to distinguish among groups rather than among individuals (Riesch et al., 2006). Within the stereotyped group signatures, however, the frequency contours of individuals exhibit a level of inter-individual variability which is high enough to discriminate among different animals (Nousek et al., 2006).

Mysticete vocal anatomy is homologous to that of terrestrial mammals (Reidenberg & Laitman, 2007). One notable difference, however, is the presence of a U-shaped structure supported by cartilage thought to be a homolog of the vocal folds in terrestrial mammals (Reidenberg & Laitman, 2007). Although it differs in its orientation within the larynx compared to terrestrial mammals, this “U-fold” is likely under similar muscular control and serves as the

vibrating sound source in baleen whales. Baleen whales also possess a laryngeal sac ventral to the larynx which may serve as an accessory air source in addition to the lungs (Adam et al., 2013; Cazau et al., 2013; Reidenberg & Laitman, 2007; Schoenfuss et al., 2014). According to model-based approaches along with anatomical study, Cazau et al. (2013) propose that different configurations of the vocal anatomy may account for the various categories of calls—pure tonal, tonal with formants, and pulsatile—known to be produced by baleen whales. Although the study by Cazau et al. (2013) used humpback whales (*Megaptera novaeangliae*) as its model, the vocal anatomy of balaenid whales (*Balaena mysticetus*, *Eubalaena* spp.) is similarly arranged to that of humpbacks (Reidenberg & Laitman, 2007; Schoenfuss et al., 2014), and the same overall pattern is plausible in those species.

Despite the homology of the mysticete vocal anatomy with terrestrial mammals and the corresponding implications for individually distinctive features based on the source-filter theory, there have been no explicit studies of identity signaling in this group. This gap is particularly surprising given the body of literature suggesting possible communication networks that may require individual recognition (e.g., (Hamilton & Cooper, 2010; Ramp et al., 2010; Weinrich, 1991) and the use of passive acoustic monitoring to assess distribution and abundance of these whales (Clark & Clapham 2004; Mellinger et al. 2007; Van Parijs et al. 2009).

The North Atlantic right whale (*Eubalaena glacialis*) is one of the most closely studied mysticete whales in the North Atlantic (Kraus & Rolland, 2007). Due to its critically endangered status and slow population recovery rate (Waring et al., 2014), there has been a great interest in tracking the population and distribution of these whales within their coastal habitat. Moreover, the acoustic repertoire of the North Atlantic right whale is relatively well-described and has been used to remotely monitor the presence and behavior of these whales (Mellinger et al. 2007; Parks

& Clark 2007; Clark et al. 2007; Parks et al. 2011). As with all other mysticete whales, however, no study has yet explored individuality in the calls of the North Atlantic right whale despite the inherent assumption of some level of recognition within a likely contact call—the “upcall” (Parks & Tyack, 2005). The upcall of right whales has been used as a primary cue to species presence via passive acoustic monitoring. Determining whether individually distinctive cues are present in this call will not only provide insight into the vocal production mechanism and acoustic behavior of right whales, but it will also improve monitoring efforts, allowing a greater resolution of information from remote recorders (e.g., Mellinger et al. 2007).

Study System: the North Atlantic right whale (*Eubalaena glacialis*)

Habitat Usage and Distribution

The North Atlantic right whale occupies a coastal range extending along the eastern coast of North America (Kraus & Rolland, 2007). Right whales are routinely found in five major habitat areas within the United States and Canada: Bay of Fundy/Grand Manan Basin, Roseway Basin, Cape Cod Bay, Great South Channel, and Southeast United States (Kraus & Rolland, 2007). Due to their risk of collisions with vessels and entanglement in fishing gear, all five habitat areas have been incorporated into conservation and management areas. In the United States, the Great South Channel, Cape Cod Bay, and Southeast habitats have been listed as critical habitat areas and established as Seasonal Management Areas (SMAs). SMAs include mandatory reductions in shipping speed during the times that whales are most likely to be in those habitats (Lagueux et al., 2011; Merrick, 2005). In Canadian waters, the Roseway Basin and Grand Manan Basin Right Whale Conservation Areas have guidelines for speed reductions,

although these areas do not have legislated regulations as in the United States critical habitat areas (Hoyt, 2011).

Each year, pregnant females, adult males, and some juveniles of the North Atlantic right whale population migrate from high-latitude summer feeding areas in the Gulf of Maine and Bay of Fundy to low-latitude winter calving areas off the Southeastern United States (Kraus & Rolland, 2007). Unlike other baleen whale species (e.g., humpback whales (Katona & Beard, 1990)), this migration does not involve a large portion of the population. Rather, a combination of visual surveys and passive acoustic monitoring has confirmed the presence of North Atlantic right whales in high-latitude habitats year-round; however the specific habitat use in these locations is still unknown and may vary according to site (Mellinger et al., 2007; Bort et al., 2015).

Social System

Although typically considered as a solitary species since they do not travel in tightly associated pods (e.g., May-Collado et al., 2007), right whales frequently engage in social interactions with conspecifics (Kraus & Hatch, 2001; Parks et al., 2007; Kraus et al., 2007). In all habitat areas, right whales can be found engaging in surface active groups (SAGs) involving at least two whales interacting in close proximity at the surface (Kraus & Hatch, 2001; Parks et al., 2007; Kraus et al., 2007). Whales from all age classes and both sexes engage in SAGs, and group compositions range from all juveniles to all adult and all female, mixed sex, to all male groups (Parks et al., 2007). Originally proposed as mating groups due to the high visibility of sexual interactions (Kraus & Hatch 2001), there have also been observations of all-juvenile SAGs and all-male SAGs involving sexual behaviors (Parks et al., 2007). All-female SAGs have also been

observed, indicating that the SAG may function in diverse social contexts (Parks et al., 2007). Despite the seasonal calving intervals, there is also no seasonal restriction to SAGs to suggest fertilization occurs solely as a result of these groups, and the groups have been documented in both feeding areas and calving areas (Parks et al., 2007). A subset of SAGs, however, are thought to result in reproduction, taking the structure of a central female with several males competing for the “alpha” position adjacent to the female to increase their chances of mating success (Kraus & Hatch, 2001; Kraus et al., 2007).

Along with short-term SAGs, North Atlantic right whales likely engage in long-term social interactions. A standard definition of “association” in baleen whales consists of two or more individuals within one or two body lengths of each other and traveling in the same direction or exhibiting synchronous behaviors (Mobley & Herman, 1985; Weinrich, 1991). This definition does not take into account the primarily acoustic world of baleen whales, where individuals could easily be associated acoustically while separated by relatively large distances of hundreds to thousands of meters. Hamilton (2002) discusses several important observations regarding sociality in the North Atlantic right whale. In all habitats except Massachusetts Bay (Cape Cod Bay), right whales formed non-random associations with other individuals. In both the Roseway Basin feeding area and the Southeast US calving area, strong bonds among individuals were represented more than in other habitat areas. The Bay of Fundy habitat also exhibits non-random associations; male-male and female-female associations were most prevalent. While Hamilton (2002) excludes mother-calf pairs from his analysis, Hamilton and Cooper (2010) show that mother-calf pairs can remain associated after the first year, and mothers were observed with previous calves in the Southeast US habitat despite not calving that year.

Although these studies offer invaluable information about sociality, they are necessarily limited by visual observation methods. Indeed, the very definition of an association between two whales is biased by what an observer can see at the surface, but as a species dependent on acoustic communication, right whales could likely remain acoustically associated at distances on the scale of kilometers. Propagation testing of upcalls produced by the closely related North Pacific right whale (*E. japonica*) indicate that some acoustic features of the upcall are still present even at ranges over 20km (McDonald & Moore, 2002; Munger et al., 2011).

Acoustic Behavior

The acoustic repertoire of the North Atlantic right whale is well-studied and includes broadband sounds, variable tonal calls, and stereotyped tonal calls (Bort et al., 2015; Matthews et al., 2014; Parks et al., 2005; Parks & Tyack, 2005; Parks, 2003; Parks et al., 2011). Broadband sounds known as “gunshots” are known to be produced by males and, based on analysis of seasonal occurrence of gunshots, are likely used in a reproductive context (Matthews et al., 2014; Parks et al., 2005; Parks & Tyack, 2005) (Fig. 1). Variable tonal calls include high-frequency “scream” calls associated with SAGs, potentially used by adult females to attract other whales to participate in a SAG (Parks, 2003) (Fig. 1).

The upcall of the North Atlantic right whale is a stereotyped tonal call produced by all North Atlantic right whales (Fig. 1) (Parks & Tyack, 2005; Parks & Clark, 2007). The call is also produced by North Pacific right whales (*E. japonica*) (McDonald & Moore, 2002) and Southern right whales (*E. australis*) (Clark, 1982) and is named for the increase in frequency from approximately 100Hz to 400Hz over its duration (Clark, 1982). The presumed function of the call is to maintain acoustic contact among individuals and potentially facilitate reunion or joining

events (Clark, 1982). During playback experiments, Southern right whales responded to playbacks of upcalls with upcalls of their own and swam towards the experimental speaker, providing evidence for this call as a contact call (Clark & Clark, 1980).

Hypothesis

Based on the proposed social context of the upcall and its acoustic structure, I hypothesize that upcalls of North Atlantic right whales contain acoustic cues that will allow for statistical discrimination of age, sex, and individual identity. To test this hypothesis, I will measure source-related and filter-related characteristics of the vocalization produced by different individual whales.

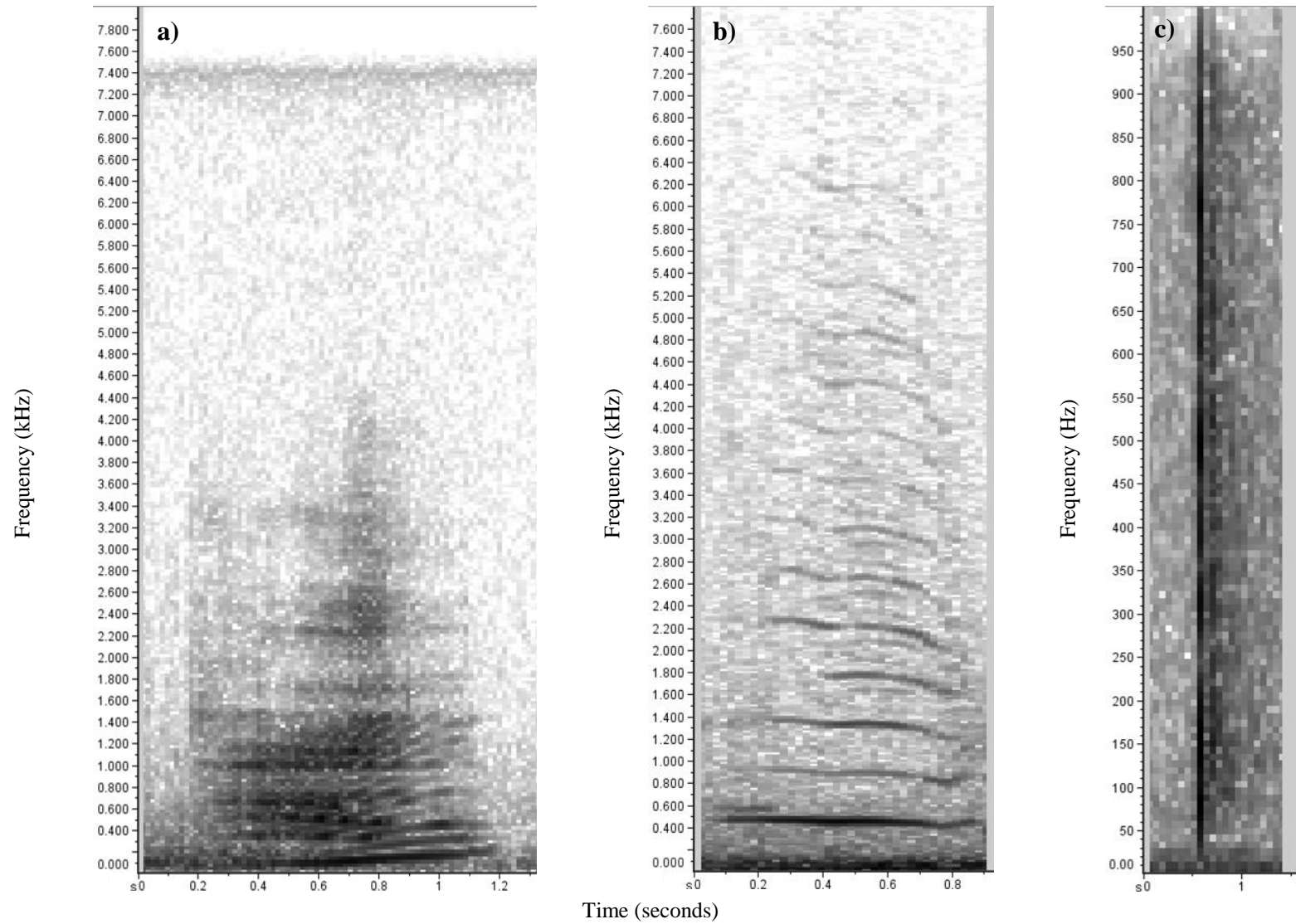

Figure 1: Spectrograms representing the major calls within the North Atlantic right whale repertoire: (a) the upcall—a stereotyped tonal call, (b) the scream call—a variable tonal call, and (c) the gunshot—a short duration broadband call. Note the different frequency scale for the gunshot.

METHODS

Data collection

Archival Tags

Data were collected through digital archival acoustic recording tags (Dtags) attached to 88 individual North Atlantic right whales with four silicone suction cups (Nowacek et al., 2001; Johnson & Tyack, 2003; Nowacek et al., 2004; Friedlaender et al., 2009; Parks et al., 2011) in three critical habitat areas (Table 1). This dataset represents all existing Dtag records from North Atlantic right whales collected between 2001 – 2014.

Prior to tagging, all whales were photographed to visually determine their identity. Right whales have individually distinctive patterns of rough patches of skin called callosities on their rostrum, mandibles, and near the blowhole (Hamilton et al., 2007). Photographs of whales were compared to the North Atlantic Right Whale Catalog (NARWC) to confirm the identity of each whale.

After a period of behavioral observation and photo-identification to determine the identity of the tagged whale, Dtags were deployed by small (> 10m) vessels using a handheld or cantilever carbon-fiber pole with a housing that holds the tag at the end of the pole until it is secured on the whale. The tag contains an anodic corrosive wire designed to release the tag from the whale at a predetermined time up to 24h after deployment, although most tags release before this time due to skin sloughing, contact with other whales, or other forces (Nowacek et al., 2001).

Dtags were equipped with a hydrophone, three-axis accelerometer, compass, and pressure sensor (Johnson & Tyack, 2003; Nowacek et al., 2001). For this study, I used only the acoustic data from the tag records.

Table 1: Summary of data collection, including all Dtag records. Number of tag records containing upcalls, the call of interest for this study, are shown in parentheses.

Habitat Area	Months	Years	Total number of tag records analyzed (records containing focal upcalls)	Citation
Bay of Fundy, Canada	July, August	1999 – 2005	58 (13)	Johnson & Tyack, 2003; Nowacek et al., 2004; Parks et al., 2011; Parks et al., 2011
Cape Cod Bay, MA, United States	April	2009, 2010	18 (5)	Parks et al., 2012
Southeast United States	January, February	2006, 2014	12 (6)	Parks and Nowacek, unpublished data

Determining age and sex

The NARWC also contains data regarding sex and age of cataloged whales. Sex was determined using either visual assessment of the genital slit (Payne & Dorsey, 1983) or genetic information obtained via skin biopsy (Brown et al., 1994). Exact age was only known if a right whale was sighted with its mother during its first year, but minimum age for other whales can be estimated as the number of years elapsed since the first sighting of the animal. The average age of first calving for female right whales is nine years of age (Kraus & Hatch, 2001; Payne & Dorsey, 1983); thus, for this study, whales were considered juvenile if their exact age at time of tagging was known to be between one and eight years of age. Whales were considered as adults if their exact age or minimum age at time of tagging was nine years old or greater.

The distinction between sexually mature and sexually immature individuals does not, however, reflect any difference in size which may influence acoustic parameters of the upcalls.

Right whales grow quickly in their first year but exhibit a dramatic decrease in growth rate between 1 and 2 years of age (Fortune et al., 2012). To account for this, age was separately categorized by size, where small whales between one and two years of age were separated from large whales that had an exact age or minimum age of three years of age or older.

Call detection and acoustic measurements

Spectrograms of complete recordings from Dtags were visually inspected for presence of upcalls using Raven Pro 1.5 (Cornell Bioacoustics Research Program 2014). To ensure selection of calls from the focal (tagged) animal, I only used upcalls with a high signal-to-noise ratio (SNR) (> 10 dB) produced when the tagged whales were also noted to be >5 body lengths away from any other whale, providing a high confidence that the call was produced by the tagged whale (e.g., Parks et al. 2011) ($N = 24$ individuals). These upcalls were then extracted from the full tag record as individual files. Waveforms of these files were examined in Raven Pro 1.5 to determine whether the amplitude of the signal exceeded the dynamic range of the recorder, a phenomenon known as clipping. Any clipped files were excluded from further analyses. Depending on the deployment, the hydrophone recorded acoustic data at sample rates between 16 and 96 kHz. Since acoustic sampling rate affects the resolution of the data and any subsequent visualizations such as spectrograms, remaining files were resampled to the lowest sample rate for any tag, 16kHz, using AviSoft SASLab Pro (Avisoft Bioacoustics, 2013). Additionally, to improve validity of classification analysis, whales with fewer than 3 calls were excluded, leaving a total of 13 individuals (Table 2).

Table 2: Tag records used in analysis. SEUS = Southeast United States, BOF = Bay of Fundy, Canada, CCB = Cape Cod Bay, Massachusetts, USA; EGNO = NARWC catalog number; M = male, F = female, J = juvenile (< 9 years old), A = adult (\geq 9 years old), S = small (< 3 years old), L = large (\geq 3 years old), U = unknown.

Habitat	Year	Julian Day	EGNO	Sex	Age Class (Reprod.)	Age Class (Size)	Exact Age at time of tagging	Minimum age at time of tagging	Tag Duration (hh:mm:ss)	Number of focal upcalls
SEUS	2006	21	3442	M	J	S	2	--	1:21:07	7
SEUS	2006	24	3430	F	J	S	2	--	0:54:06	5
SEUS	2014	40	2123	F	A	L	23	--	1:33:27	10
CCB	2009	107	3579	M	J	L	4	--	4:02:26	12
CCB	2010	93	3610	M	U	L	U	4	3:04:57	3
CCB	2010	95	3101	F	A	L	9	--	4:02:56	4
BOF	2001	227	2145	F	A	L	10	--	4:11:37	23
BOF	2002	221	2350	M	A	L	U	11	7:54:00	3
BOF	2002	222	3103	F	J	S	1	--	1:44:00	6
BOF	2005	210	3323	M	J	L	3	--	10:52:00	10
BOF	2005	213	1241	F	A	L	23	--	0:20:00	66
BOF	2005	215	2413	F	A	L	11	--	11:20:00	7
BOF	2005	226	3360	F	U	U	U	2	9:00:00	5

Acoustic Measurements

Three groupings of variables were measured for this study: time-frequency, formant, and amplitude (Table 3). Time-frequency variables include duration, duration 90%, frequency contour, minimum frequency, maximum frequency, start frequency, and end frequency. Formant variables include frequency of formants 1 – 3, bandwidth of formants 1 – 3, ratio of formant 2 to formant 1, ratio of formant 3 to formant 2, and ratio of formant 3 to formant 1. Amplitude variables include the root mean square (RMS) amplitude for quartiles 1 – 4, maximum amplitude for quartiles 1 – 4, and minimum amplitude for quartiles 1 – 4.

Time-frequency measurements

Spectrograms of individual upcall files were visually inspected in Raven Pro 1.5 (Hann window, window size = 2048 points, sample rate 16 kHz, overlap = 50%, frequency resolution = 7.81Hz, time resolution = 64ms, view y-axis = 0 – 1 kHz, view x-axis = 5.983s), and selection boxes were manually drawn around the fundamental frequency to restrict measurements of the frequency contour to the fundamental frequency of the calls. Individual frequency values for each successive spectral slice were stored as separate variables for each call, allowing for direct comparison of the frequency content at the same point in time within the call (Fig. 2).

Formant measurements

I measured formants using Praat (version 5.3.17, Boersma & Weenik 2012), an open-source speech analysis software. Praat measures formants using linear predictive coding (LPC), and this method is sensitive to false positive measurements from background noise, particularly in higher frequencies where the SNR of formants decreases. To reduce the effects of this noise, I used Adobe Audition 3.0 (Adobe Systems Incorporated, 2007) to remove background noise from files. Once sound files were loaded into Adobe Audition 3.0, I selected a portion of background noise at least 0.128s in length (2048 sample points) that occurred a minimum of 0.5s before the onset of the call and captured it as a noise reduction profile to be used in the Noise Reduction process within Adobe Audition 3.0. This tool loads a power spectrum of the background noise and then subtracts a fraction of those frequencies from the rest of the file. Settings of the Noise Reduction process were as follows: FFT size = 2048, noise reduction level = 100%, attenuation level = 40dB, precision factor = 7, smoothing factor = 1, transition width = 1dB, spectral decay rate = 65%. Spectrograms were visually assessed after de-noising to ensure that the formant structure was not degraded by noise removal.

De-noised files were read into Praat, and the frequency values of the formants were automatically extracted using the ‘LPC: To Formant (Burg)’ command. Analysis parameters were as follows: time step = 0.0 (auto), maximum number of formants = 4, maximum formant = 5500Hz, window length = 0.025s, pre-emphasis from 50Hz. The first three formants were used in analysis based on the discussion of the decreased performance of formant tracking by Praat when measuring the maximum formant (Vannoni & McElligott, 2007). Formant values and bandwidths were then saved in comma separated files, and the mean measurement of each of the first three formants and corresponding bandwidths were used as the formant values of each call for analysis (Fig. 3).

Amplitude measurements

Using Raven Pro 1.5, new selection boxes were generated based on those used for the Peak Frequency Contour measurements. To measure amplitude for the entire call including all three formants, boxes were extended to include frequencies up to 3.5 kHz. Selections were then divided into equal-duration quartiles to capture amplitude differences over the course of a single call. Maximum amplitude, minimum amplitude, and root mean square (RMS) amplitude (Raven units) were measured for each call, and all amplitude measurements were normalized as a fraction of the maximum peak-to-peak amplitude for a given tag record (Fig. 4).

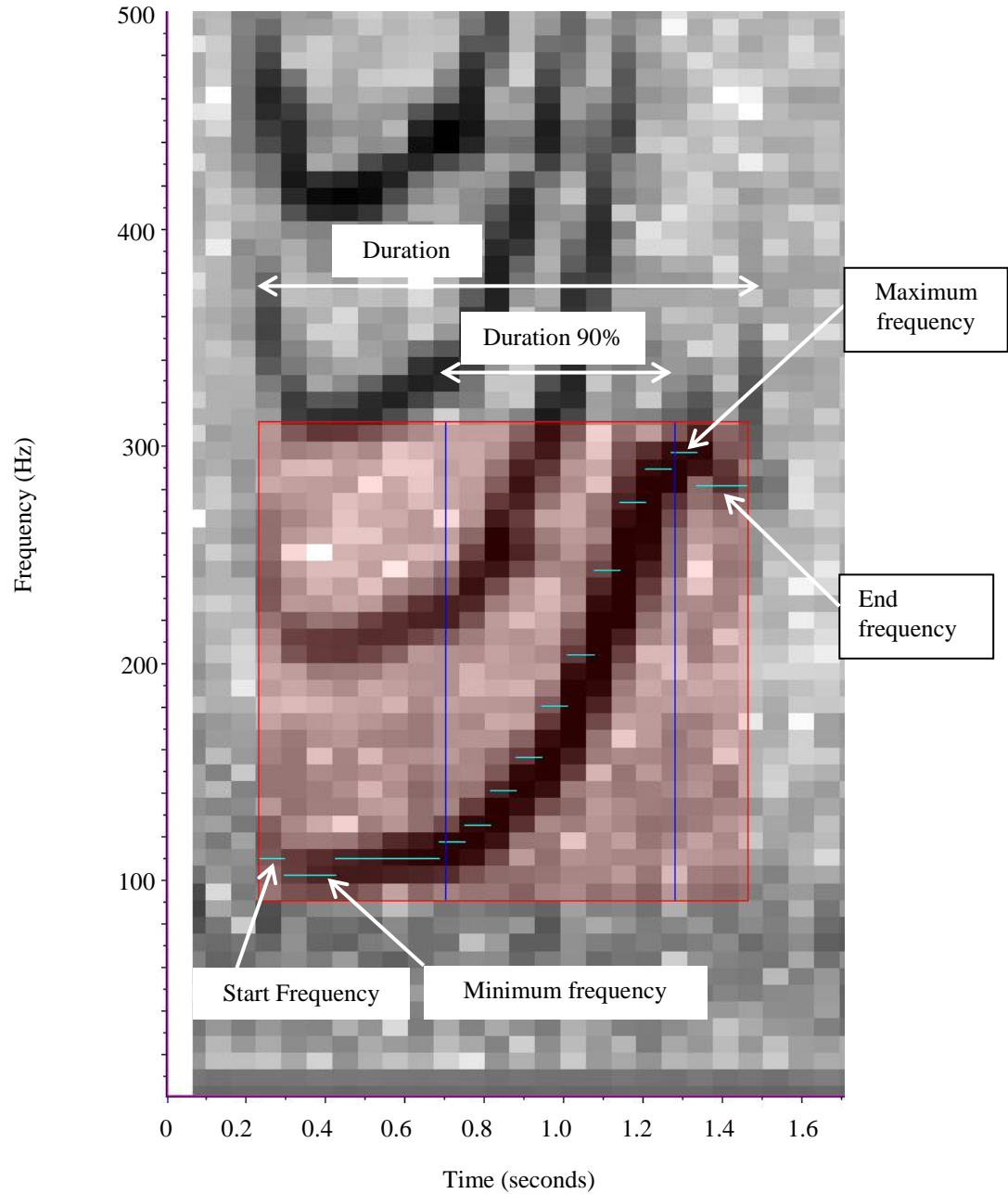

Figure 2: Spectrogram showing time-frequency measurements of an upcall in Raven Pro 1.5. Selection box shown in red, frequency contour measurements are shown in light blue, and the time points marking 5% (left) and 95% (right) of the spectrogram power spectral density are shown in dark blue. Spectrogram parameters same as described in text for time-frequency measurements

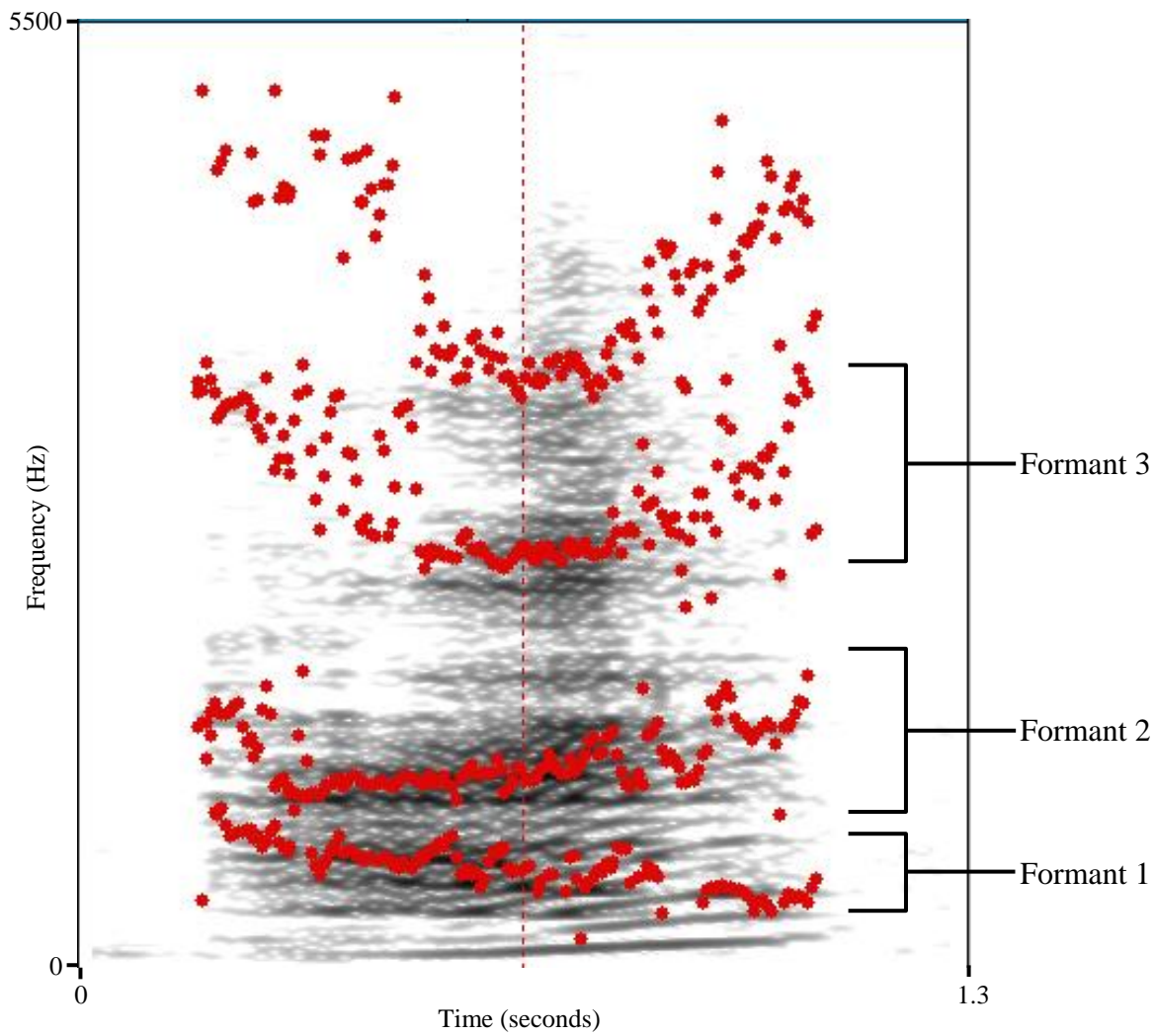

Figure 3: Formant measurements from Praat spectrogram. Red dots indicate measurement of formant values for each time window (0.025s). Brackets indicate approximate frequency locations of first three formants.

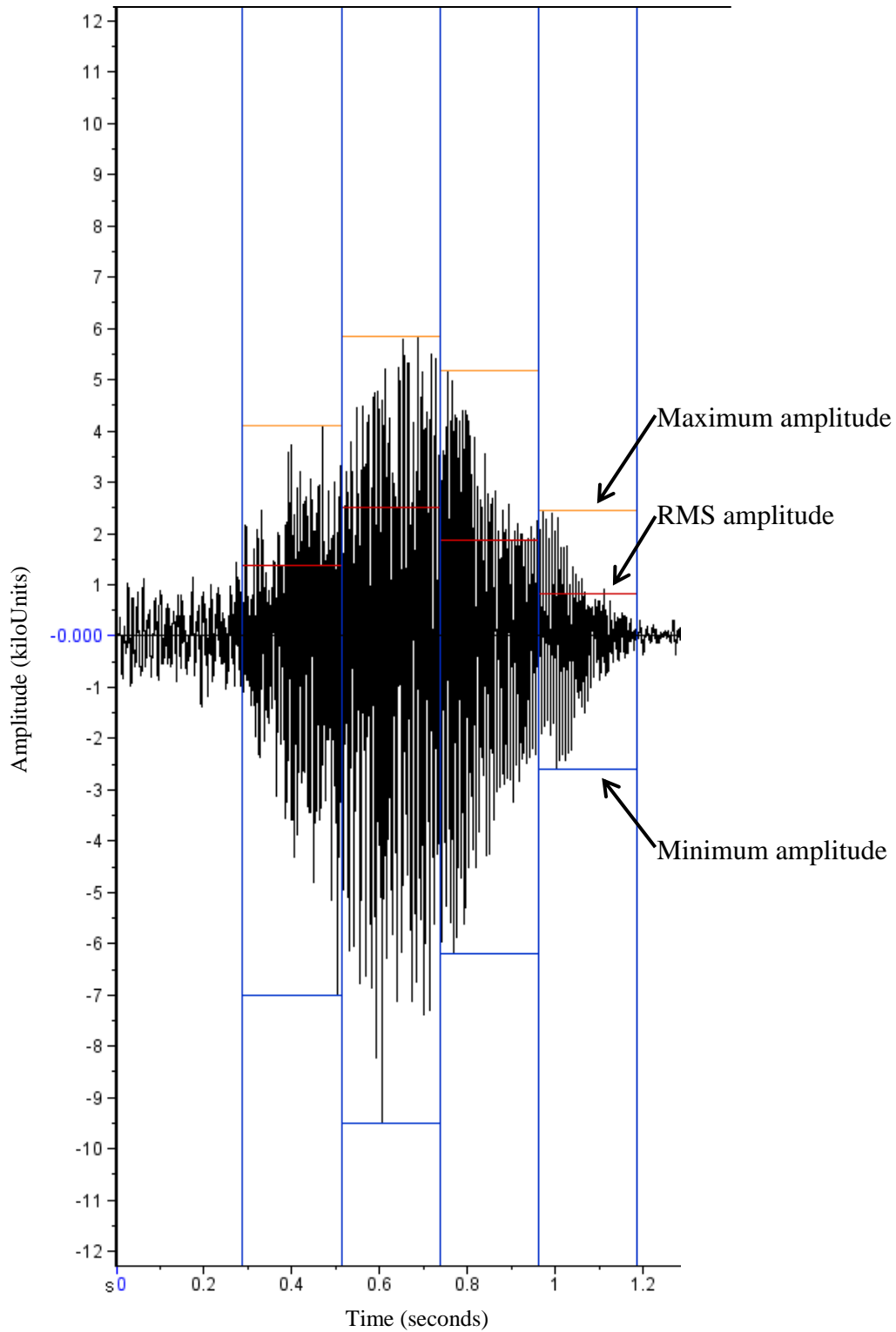

Figure 4: Amplitude measurements from waveform in Raven Pro 1.5. Vertical bars represent divisions between four equal-duration quartiles. Maximum, RMS, and minimum amplitude measurements are color-coded (orange, red, blue, respectively) and are explicitly indicated in the fourth quartile.

Table 3: Explanation of acoustic measurements. Time-frequency and formant measurements were taken from the spectrogram, and amplitude measurements were taken from the waveform.

Parameter	Class	Description
Duration (s)	Time-frequency	Total length of selection box, calculated as End Time - Begin Time
Duration 90% (s)	Time-frequency	Difference between time points marking 95% and 5% of spectrogram power spectral density
Frequency Contour (Hz)	Time-frequency	Contour composed of discrete values calculated by measuring the peak frequency of each successive spectrogram slice within the selection. Number of frequency contour values varies according to the duration (range 8 – 32 values)
Minimum Frequency (Hz)	Time-frequency	Minimum value in Frequency Contour
Maximum Frequency (Hz)	Time-frequency	Maximum value in Frequency Contour
Start Frequency (Hz)	Time-frequency	First value in Frequency Contour
End Frequency (Hz)	Time-frequency	Last value in Frequency Contour
Formant 1 and Bandwidth (Hz)	Formant	Mean value of frequency and bandwidth measurements from first formant for each call
Formant 2 and Bandwidth (Hz)	Formant	Mean value of frequency and bandwidth measurements from second formant for each call
Formant 3 and Bandwidth (Hz)	Formant	Mean value of frequency and bandwidth measurements from third formant for each call
Formant 2:Formant 1	Formant	Ratio calculated by dividing the second formant by the first formant
Formant 3:Formant 2	Formant	Ratio calculated by dividing the third formant by the second formant
Formant 3:Formant 1	Formant	Ratio calculated by dividing the third formant by the first formant
RMS amplitude (Raven units) (Quartiles 1 - 4)	Amplitude	Root mean square amplitude, normalized to maximum peak-to-peak amplitude for a given call
Minimum Amplitude (Raven units) (Quartiles 1 - 4)	Amplitude	Minimum amplitude, normalized to maximum peak-to-peak amplitude for a given call
Maximum Amplitude (Raven units) (Quartiles 1 - 4)	Amplitude	Minimum amplitude, normalized to maximum peak-to-peak amplitude for a given call

Statistical Analysis

All variables were assessed for normality using Q-Q plots of values of each variable plotted against a theoretical normal distribution. The only measurement variables that were not normally distributed were the four minimum amplitude measurements, and these were log-transformed to achieve normality for further analyses. A multivariate analysis of variance (MANOVA) was performed to determine whether statistical differences exist among groups for all call parameters prior to further analyses. The resulting call parameters were then used to classify calls to age class, sex, and individual and to determine which variables were important for discrimination, three analytical tools were used: principal components analysis (PCA), discriminant function analysis (DFA), and classification and regression trees (CART). PCA and DFA were conducted in SPSS Version 22.0 (IBM Corp, 2013), and CART was done in R (version 2.15.2, R Core Team 2012).

Principal Components Analysis

The SPSS Factor Analysis tool was used to conduct a PCA using all of the measurement variables as well as different combinations of time-frequency, formant, and amplitude variables. Principal Components Analysis (PCA) is a nonparametric analysis that reduces dimensionality of the data by redefining values according to principal components that describe the maximum variation in the data. Prior to conducting each PCA in SPSS, the suitability of the data for component analysis was assessed using the Kaiser-Meyer-Olkin (KMO) test and Bartlett's test of sphericity. The KMO test measures sampling adequacy by determining the proportion of variance caused by underlying factors within the dataset; high values (>0.6) indicate that factor analysis will be useful. Bartlett's test of sphericity tests the null hypothesis that all measurement variables are unrelated (i.e., the correlation matrix is an identity matrix) (Parinet et al., 2004). For

all sets of variables, the KMO value was greater than 0.6 and the Bartlett's test of sphericity resulted in $p < 0.05$, meaning the dataset is well-suited for PCA. The total number of components is equal to the number of measurement variables, but a component will only be extracted from the list of total components if its initial eigenvalue, a measure of the variance explained by each component, is greater than 1. The importance of each variable on the principal components can be determined using its principal component loadings, expressed as the correlation of each variable with the corresponding component. For this study, variables with a correlation coefficient $> |0.5|$ were identified as important variables for a given component. After the PCA was completed, PCA scores were used as inputs to a discriminant function analysis (see method below) to determine which groupings of variables resulted in principal components that are best suited to discriminate between age classes, sexes, and individuals (e.g., Vannoni & McElligott 2007).

Discriminant Function Analysis

To evaluate the effect of continuous variables on group membership, I ran DFA using the Discriminant Analysis tool in SPSS using all variables as well as different combinations of time-frequency, formant, and amplitude measurements. To test any discrimination which may be explained by the principal components, I also ran a DFA using the principal component scores of all calls as dependent variables and the categories mentioned above as the independent variables. The analysis creates sets of functions that result in the greatest separation of groups. Each function takes the linear form

$$Y_D = \beta_1 X_1 + \beta_2 X_2 + \dots + \beta_k X_{k-1}$$

where Y_D is the discriminant score, X represents each measurement variable, and β is the coefficient that best separates the groups. The number of functions is equal to either the number

of measurement variables or the number of groups minus one, whichever is smaller. In this particular study, stepwise DFA produced 1 function when classifying age class and sex (N of groups $- 1$) and a maximum of 12 functions when classifying by individual (N of individuals $- 1$). To predict membership of each case (call) within a class—age class, sex, individual—DFA standardizes all coefficients to a Z-score (mean = 0, SD = 1) to produce discriminant scores for each case. The assigned scores are then used to predict group membership and a canonical score for the group centroid. The scores of the first two discriminant functions of each case were plotted to visually assess any clustering patterns and overlap among age classes, sexes, or individuals.

To assess the relative classification success using different types of measurements, I ran a stepwise DFA with different combinations of variables as an indication of the relative contributions of the source- and filter-based parameters. Stepwise DFA is a more conservative approach as it only includes those variables which are most important to separating the groups rather than using all possible variables as in a full DFA. The importance of a measurement variable in the stepwise process is determined by the F value of the regression coefficient that variable would have if it were included in the equation. At each “step” a new measurement variable is considered and the F values of the new variable and remaining variables are assessed. If the F value of the new variable is high enough, it is included in the next step. Likewise, if the F value of a variable that is already included in the analysis decreases beyond a certain threshold, it is removed (criteria used for this analysis: $F > 3.84$ to enter, $F < 2.71$ to remove). Prior probabilities were based on group size (number of calls per individual or age/sex group) in all analyses. Cross-validation using the “leave-one-out” method was also done in SPSS to assess the relative performance of each classification analysis.

Important variables were chosen as variables included in the final stepwise DFA that also had their highest correlation with a canonical discriminant function that was determined to be significant ($p < 0.05$) according to a X^2 test with degrees of freedom based on the number of individuals (categorical variable) and the number of continuous discriminant variables. The X^2 test in this case tests the null hypothesis that the canonical discriminant function is equal to zero, or that addition of the function adds no further discriminating ability (e.g., Boughman 1997).

Classification and Regression Trees

Classification and Regression Trees (CART) uses recursive partitioning to create a bifurcating tree based on measurement values that best split the data. Splits are assessed using a measure of impurity, or the proportion of cases belonging to the non-majority group after each split. CART analysis was completed using the function “rpart” included in the R package “rpart” (Therneau et al., 2014). Since the tree is partitioning the data according to membership within categories, the ‘class’ method was used in the function. Trees were initially computed with a minimum of 2 cases (calls) per terminal node and then pruned to reflect the tree with the lowest standardized cross-validation error (Legendre & Legendre, 2012). I ran the CART analysis using all measurement variables as well as combinations of time-frequency, formant, and amplitude variables. Terminal nodes are labeled as the category with the majority of cases assigned to that node; misclassified calls, therefore, are any calls assigned to a particular terminal node which do not belong to that category. Percent correct classification was calculated using the number of misclassifications at the terminal nodes for the entire pruned tree. Cross-validation using the “leave-one-out” method was also done using the “rpart” package to assess the relative performance of each classification analysis.

RESULTS

Analyses of age class discrimination by reproductive status were performed using 148 calls from 11 individuals (6 adults, 5 juveniles), analyses of age class discrimination by size were performed using 151 calls from 12 individuals (9 larger, 3 smaller), and analyses of sex and individual discrimination were performed using 161 calls from 13 individuals (5 males, 8 females; median number of calls per individual = 7, range = 3 – 66 calls per individual). The MANOVA for each grouping—age, size, sex, and individual—confirmed presence of group differences in measurement parameters ($p < 0.001$ for all analyses; age: $F_{1,146} = 3.37$; size: $F_{1,149} = 4.38$; sex: $F_{1,159} = 2.70$; individual: $F_{12,148} = 2.40$). Descriptive statistics for important classification variables described below are found in Table 1, Appendix A.

Principal Components Analysis

Principal components analysis was performed on all calls ($N = 13$ individuals, 161 calls) to determine the components which best describe the variation in the data. All PCA results including important variables for each analysis are summarized in Tables 2 – 8, Appendix A. A brief summary of PCA results is presented in Table 4. The PCA using all variables resulted in 13 principal components that describe 82.1% of variance. All cases are plotted in a scatterplot matrix of the first three components, which describe 42.5% of the variance (Fig. 5). To discriminate between age classes, the PCA using a combination of time-frequency and formant variables produced components which in turn represented the highest correct classification (80.4%) when used as inputs to stepwise DFA. To discriminate between sexes, the PCA using all variables produced components which in turn represented the highest correct classification (77.0%) when used as inputs to stepwise DFA. To discriminate among individuals, the PCA

using a combination of time-frequency and amplitude variables produced components which in turn represented the highest correct classification (71.4%) when used as inputs to stepwise DFA. Scatterplot matrices for age and sex discrimination are presented in Figs. 1 – 3, Appendix B.

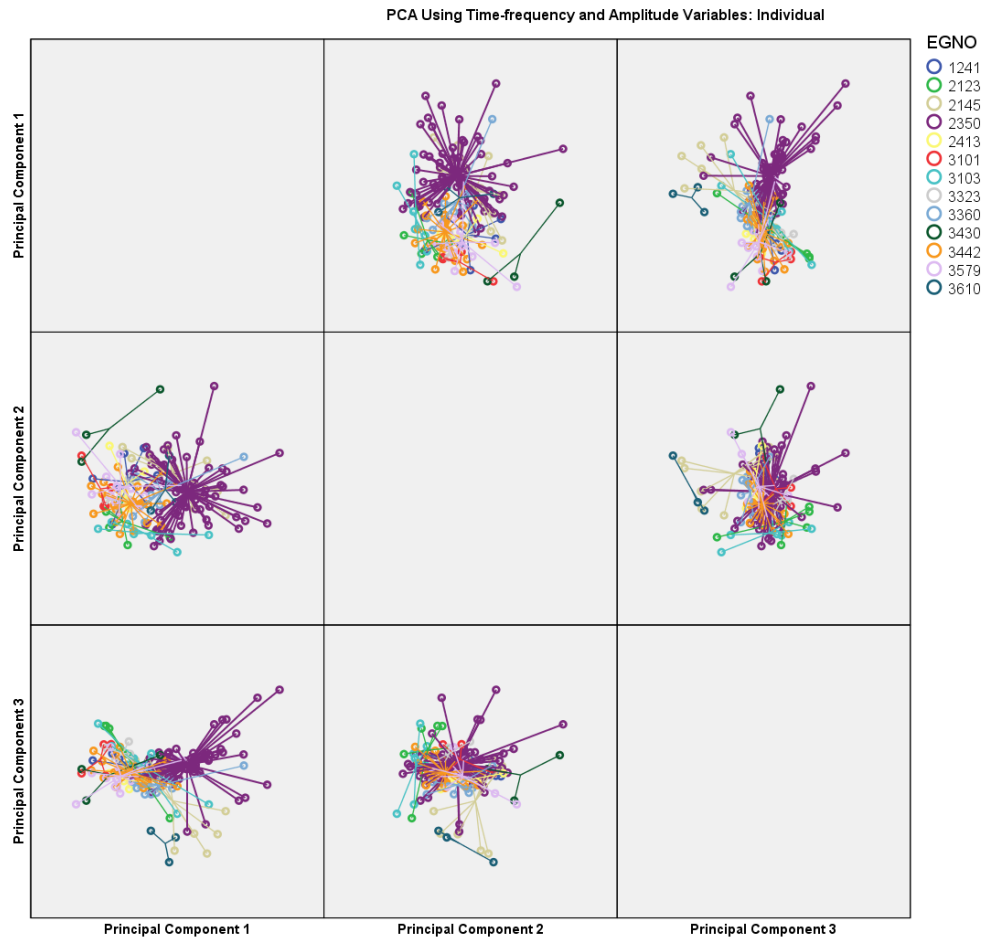

Figure 5: Scatterplot matrix of first three principal component scores of the PCA using time-frequency and amplitude variables. The first three components explained 48.4% of the variation in the data, and all 9 components in the analysis explained 79.4%. Colors indicate individual whales, and lines are drawn from each call to the group centroid of principal component scores for that individual.

Table 4: Percent variance explained by all principal components and first three principal components when analysis was completed for different variable groupings

	% Variance explained by all components	Total number of principal components	% Variance explained by first three components
Formants	77.6	3	77.6
Amplitude	88.7	3	88.7
Time-frequency	78.2	7	55.6
Time-frequency + formants	79.3	10	46.6
Time-frequency + amplitude	79.4	9	48.4
Formants + amplitude	84.9	6	66.0
All	82.1	13	42.2

Discriminant Function Analysis

All stepwise DFA results including a list of important variables for each analysis are summarized in Tables 9 – 12, Appendix B. A plot of discriminant scores for all calls based on the DFA using all variables to discriminate among individual callers is shown in Fig. 6. Plots of discriminant scores for the combinations of variables resulting in the highest percentage of correct classifications for the other categories—age class based on reproductive maturity, age class based on approximate size, sex—are shown in Figures 4 – 6, Appendix B. For individual discrimination, time-frequency variables alone result in a higher percentage of correctly classified calls (67.7%) than either formant variables alone (42.2%) or amplitude variables alone (60.9%). When combining two groups of variables, the combination of time-frequency and amplitude variables resulted in a higher percentage of correct classification (79.5%) than either time-frequency and formant variables (72.0%) or formant and amplitude variables (57.8%). The highest classification success occurred when all three groups of variables—time-frequency, formant, and amplitude—were included in the stepwise DFA (83.2%) (Table 5).

Table 5: Percent correct classification results from stepwise DFA

Variable Groupings	Age (Reprod.) (N=11)		Age (Size) (N = 11)		Sex (N=13)		Individual (N=13)	
	% Correct Classification	Cross-validation Error (%)	% Correct Classification	Cross-validation Error (%)	% Correct Classification	Cross-validation Error (%)	% Correct Classification	Cross-validation Error (%)
Formants	77.0	23	78.1	21.9	79.5*	21.7	42.2	60.2
Amplitude	81.1*	18.9	91.4	8.6	70.2	34.8	60.9	44.1
Time-frequency	81.1*	20.3	92.1*	8.6	74.1	29.8	67.7*	39.8
Time-frequency + formants	80.4	20.3	92.7	7.9	80.1	21.7	72	39.1
Time-frequency + amplitude	82.4	20.3	94**	7.9	74.5	25.5	79.5	30.4
Formants + amplitude	83.8**	16.2	91.4	8.6	83.9**	18.6	57.8	47.2
All	80.4	20.3	94**	7.9	83.2	19.9	83.2**	26.7

*highest percent classification for a single variable grouping

**highest percent classification overall

A given variable grouping was used a maximum of four times: once with no other variables, once with each of the other two variable groupings, and once in the analysis including all variables. When discriminating between reproductive age classes, variables that were used in all four possible analyses were duration 90%, 18th frequency contour value, and the bandwidth of the third formant. When discriminating between size-based age classes, variables that were used in all four possible analyses were duration 90%, end frequency, 18th frequency contour value, 25th frequency contour value, maximum amplitude of the 4th quartile, and RMS amplitude of the 4th quartile. When discriminating between the sexes, variables that were used in all four analyses were the 21st frequency contour value, formant 2, formant 1 bandwidth, formant 3 bandwidth, formant 3/formant 1 ratio, and the log(minimum amplitude) of the second quartile. When discriminating among individuals, variables that were important in all four possible analyses were duration 90%, 18th frequency contour value, log(minimum amplitude) of the third quartile, and RMS amplitude of the fourth quartile.

Classification and Regression Trees

A full summary of the CART classification results including important variables and number of splits for each tree is presented in Tables 13 – 16, Appendix A. A brief summary of classification results is presented in Table 6. Use of all variables resulted in the pruned tree with the highest percentage of calls classified to the correct individual (Fig. 7). Pruned trees resulting in the highest percentage of correct classifications for other categories—age class based on reproductive maturity, age class based on size, and sex—are shown in Figures 7 – 9, Appendix B. In classification trees, the variable used in the first split describes the largest division in the data. For age class based on reproductive maturity, the tree produced using all variables resulted

in the highest percentage of correct classifications (94.6%), contained 7 splits, and used duration 90% to determine the first split. For age class based on approximate size, the tree produced using important variables from the DFA resulted in the highest percentage of correct classifications (94.7%), contained 6 splits, and used duration 90% to determine the first split. For sex, the tree produced using time-frequency and amplitude variables resulted in the highest percentage of correct classification (93.2%), contained 13 splits, and used the maximum amplitude of the 2nd quartile to determine the first split. For individual, the tree produced using all variables resulted in the highest percentage of correct classification (86.3%), contained 18 splits, and used duration 90% to determine the first split.

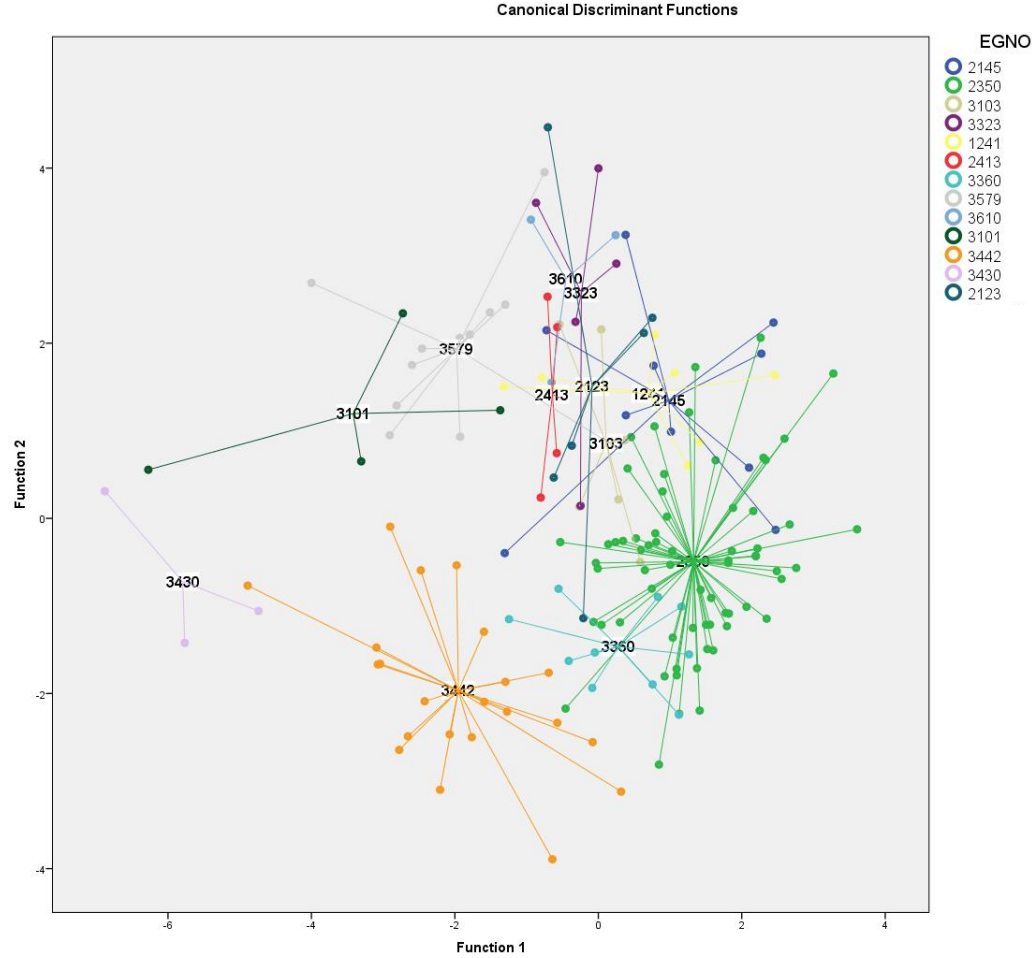

Figure 6: Canonical discriminant scores for first two discriminant functions using all variables to discriminate among individuals. Correct classification based on 9 discriminant functions was 85.1%. Colors indicate individual whales, and lines are drawn from each call to the group centroid of canonical discriminant scores for that individual.

Table 6: Classification results from CART analysis.

Variable Groupings	Age (Reprod.) (N=11)			Age (Size) (N=12)			Sex (N=13)			Individual (N=13)		
	% Correct Classification	Number of Splits	Cross-validation Error (%)	% Correct Classification	Number of Splits	Cross-validation Error (%)	% Correct Classification	Number of Splits	Cross-validation Error (%)	% Correct Classification	Number of Splits	Cross-validation Error (%)
Formants	89.2*	4	26	90.7	8	42.0	75.8	1	44.0	61.5	8	84.0
Amplitude	89.2*	5	26	91.4*	3	18.0	83.2*	4	49.0	62.1*	5	81.0
Time-frequency	85.8	4	36	89.4	1	21.0	72.7	2	55.0	61.5	4	83.0
Time-frequency + formants	91.2	4	27	92.1	2	20.0	79.5	2	52.0	58.4	3	70.0
Time-frequency + amplitude	90.5	5	31	89.4	1	18.0	93.2**	11	44.0	83.9	16	83.0
Formants + amplitude	91.9	5	28	91.4	3	16.0	75.8	1	41.0	64.6	6	84.0
DFA Variables	90.5	6	37	94.7**	6	24.0	92.5	13	42.0	73.3	12	71.0
All	94.6**	7	32	89.4	1	20.0	75.3	1	47.0	86.3**	18	68.0

*highest percent correct classification for a single variable grouping

**highest percent correct classification overall

Individual: Pruned Tree Using All Variables

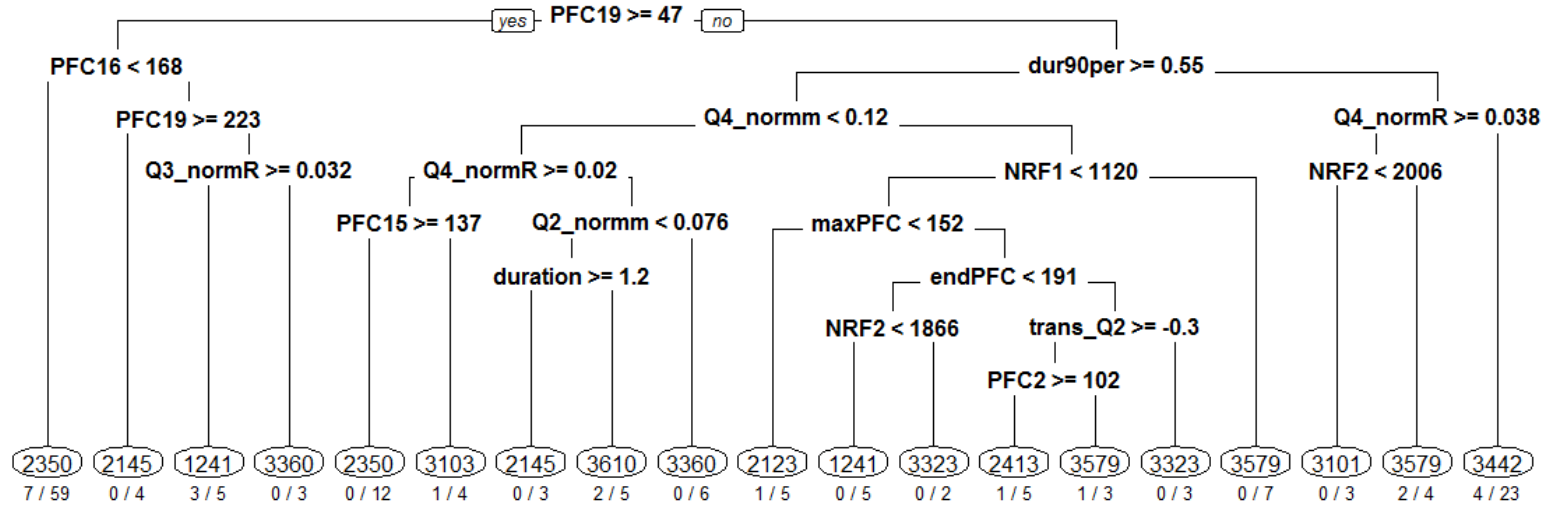

Figure 7: Classification tree using all variables to classify calls to individuals. Branches displayed to the left of a split contain cases which satisfy the criterion defined at each split. Terminal nodes are labeled with the catalog number of the individual with the majority of calls assigned to that node. Overall percentage of correct classification was 86.3%. The classification success of each node is listed as misclassifications/total number of calls.

DISCUSSION

Summary of Results

In this thesis, I examined the upcall produced by North Atlantic right whales to test for acoustic characteristics that could be used to discriminate between age classes, between sexes, and among individuals. Using Discriminant Function Analysis (DFA) and Classification and Regression Trees (CART) with the measured parameters, calls were classified to the correct age category, sex category, and individual well above that expected by random chance. For age discrimination and individual discrimination via stepwise DFA, time-frequency variables alone consistently resulted in the highest percentage of calls being correctly classified to the correct age class or individual compared to formant or amplitude variables alone. Additionally, when considering pairings of sets of variables, the combination of time-frequency variables and amplitude variables resulted in the overall highest correct classification for both age and individual. For sex discrimination, DFA using formant variables alone resulted in the highest percentage of correct classifications compared to other sets of variables alone, and DFA using the pairing of formants and amplitude resulted in the highest overall percentage of correct classification.

For CART analyses, regardless of classification group—reproductive age, size-based age, sex, individual—amplitude variables alone resulted in a higher percentage of correctly classified calls compared to formant or time-frequency variables alone. However, for all classification groups except for reproductive age class, the lowest cross-validation error was represented by a different variable grouping. In CART, the correct classifications are correlated with the number of splits, thus the performance of different variable groupings should be assessed with caution and may not be the best means of comparing CART models.

When considering specific variables, duration of the call (duration 90%) was included in all stepwise discriminant analyses for individual and age, suggesting that time-related aspects of the upcalls are most important to distinguish between age classes and among individuals. The 18th, 19th, and 21st frequency contour values were also included in several of the analyses, and the relative importance of these variables may be an effect of duration. These variables were also important in the CART analysis, with duration 90% being used to determine the first split for both types of age discrimination and the 19th frequency contour value being used to determine the first split for individual. Although not explicitly included as a separate variable, the number of frequency contour values (median = 18, range 8 – 32) serves as an additional metric of duration since the contour is sampled at equally spaced time points. Thus, for discrimination purposes, the value of the 18th – 21st frequency contours may indicate a dividing point between longer calls and shorter calls lacking information after those time points. The results of the Principal Components Analysis (PCA) also support this interpretation, as the frequency contour values of the last portion of the call were consistently grouped with duration 90% in the first component. The frequency values from the beginning portion of the call, however, were also grouped with end frequency, possibly indicating an overall frequency bandwidth effect.

Whereas duration-related parameters were most important for discriminating age and individual identity, this was not the case when discriminating between the two sexes. Unlike either age or individual, sex discrimination was most successful using formant variables. In both DFA and CART analyses, the frequency of formant 2 was important in distinguishing between the two sexes, and DFA also used the ratio between the third and first formants. The ratio between formants is a metric of formant dispersion, or the relative spacing of formant frequencies. In the PCA, when the formant variables were not combined with other variable

groupings, the majority of specific variables were used in the first component, indicating that there is an overall ‘formant effect’. In context of the importance of formant 2 for stepwise DFA and CART, measurements of additional formants may be unnecessary to achieve discrimination of sexes, but further study is needed to confirm this effect.

Stereotyped calls of other mammalian species follow a pattern similar to the North Atlantic right whale in terms of duration and frequency parameters being important for discriminating among individuals. In Amazonian manatees (*Trichechus inunguis*) (Sousa-Lima, 2002; Sousa-Lima et al., 2008) and killer whales (*Orcinus orca*) (Nousek et al., 2006), individual discrimination is possible using duration and frequency parameters, and the same features are used by Sousa-Lima et al. (2002; 2008) to distinguish calves from adult manatees. When discriminating among individual yellow-bellied marmots (*Marmota flaviventris*), Blumstein and Munos (2005) describe many frequency-related measurements, including overall duration, that contribute to identity cues.

In terrestrial mammals, formant dispersion is related to the length of the vocal tract (Charlton et al., 2011; Taylor & Reby, 2010). Although I had predicted formant variables to be important for individual discrimination (as in fallow deer (Vannoni & McElligott, 2007)), when considering the sexual size dimorphism in adult right whales (Brown et al., 1994; Payne & Dorsey, 1983) the importance of formants in discriminating between sexes still follows the source-filter paradigm in terms of lower formants with lower formant dispersion being produced in larger females. Formant frequencies did not, however, result in the highest classification success when discriminating between size-based age classes, which appears to counter the source-filter paradigm of formants as a size indicator (e.g., Reby & McComb, 2003). This unexpected result may suggest internal propagation mechanisms outside of the airways that

create unique filtering within the mysticete vocal system. Examination of this hypothesis would require modeling of tissues surrounding the vocal apparatus. If the tissues function as an additional acoustic filter, formant frequency and formant dispersion may not necessarily correspond directly with body size as in terrestrial mammals.

Improvements and Future Work

The importance of frequency variables and duration suggests that differences are most likely to be related to physiological or morphological attributes of the whale, but the corresponding importance of amplitude may be an artefact of specific tagging events. Due to the size of right whales, even when tagging the same body area, the relative location of the tag to the relevant vocal anatomy may vary among whales by meters. This distance may be enough to affect near-field propagation of the calls and result in unpredictable and unrepeatable effects on the received amplitude of the calls (Richardson et al., 1995). While specifically impacting the amplitude measurements, near-field effects may also impact measurements of formants which are extracted based on the long-term power spectrum of the call. Amplitude measurements are further complicated if the tag changes its position on the whale over the course of the tag record, which can occur often during tag deployment since the suction cups are not embedded into the skin (e.g., Parks et al. (2012) exclude data collected after shifts of the tag to retain integrity of kinematic data).

One of the biggest limitations to this study is the lack of multiple recordings of the same individual separated by time and space. Without such separation, there is a risk of idiosyncratic attributes of a particular day or tagging event that may have affected the calls of any given individual. Furthermore, knowing how whales change aspects of their identity signals as they

move through different habitats over the course of a year or if call parameters change over an individual's lifetime will also inform monitoring efforts. Given the ability to discriminate between age classes in this study, changes in vocal parameters over an individual whale's lifetime are very likely and could be measured with repeated recordings of the same animal throughout its life.

Within a single year, it is possible that changing behavioral contexts in different habitat areas (e.g., Hamilton 2002) may affect how distinctive whales are in those habitats. For example, a whale may alter its calls to be more distinctive while participating in a SAG, or a mother may have more robustly identifiable calls while she has a calf. Mother-offspring recognition has been observed in several species (Charrier et al., 2002; Sebe et al., 2007; Torriani et al., 2006) and is likely to be a strongly selected trait in right whales where calves are dependent on their mothers for their entire first year (Kraus et al., 2007). Given the dynamic nature of the marine environment, separation of mother and calf occurs frequently, and recognition of an acoustically distinctive contact call or reunion call would be a selective advantage in this species. It would be interesting to determine whether calls of calves are as distinctive as calls of older animals represented in this study and whether recognition is done by the mother, the calf, or both.

As an upcall propagates through the environment, certain aspects of the call will degrade or become distorted due to transmission loss or multipath effects. In general, lower frequencies experience less transmission loss over distance compared to higher frequencies (Richardson et al., 1995). Shallow habitats can affect propagation of calls by creating a waveguide which allows the sound waves to reflect off of the sea floor and sea-air interface (Wiggins et al., 2004). Munger et al. (2011) describe propagation effects on the upcalls of North Pacific right whales in a shallow habitat (~70m) resulting in distinct, arrivals of the call and corresponding multipath

arrivals of time- and frequency-distorted versions of the call at distances > 20 km. This likely has direct consequences for the use of duration as an identifying feature since the duration of the entire received call—including multipath signals—will change over long distances. Additionally, the increased attenuation of higher frequencies may suggest that formant information will be preferentially lost over distance, but Mercado & Frazer (1999) identify 2400 Hz as an unexpectedly optimal frequency for propagation for singing humpback whales in Hawaiian waters. In this study, the second formant was important for discriminating between sexes, and the mean value for all whales was 2015 Hz. There is a possibility, therefore, that formant information may reliably propagate through the environment and allow conspecifics to assess information about sex from upcalls.

Additionally, although Dtags are an excellent way to ensure the identity of a caller, they do not allow assessment of any aforementioned propagation effects. Using a directional hydrophone or multiple recorders, it is possible to assign calls to individual whales without using tags (e.g., Parks & Tyack, 2005). With such techniques, the propagation of specific acoustic features, especially those which are likely to encode individuality, could be measured if the same individual were recorded using a Dtag and hydrophones at varying distances. Ideally, propagation tests would also involve playing synthetically altered calls, perhaps excluding amplitude modulation or selectively removing formants, and re-recording them at known distances from the source (e.g., Charrier et al., 2009). This testing would allow researchers to analyze which call parameters are attenuated over distance, providing a means for more specific predictions for variables that may be useful to the receiver. In king penguins (Aubin et al., 2000) and black-capped chickadees (Christie et al., 2004), calls become more distinctive after propagating through the environment. Further research is needed to determine whether such an

effect might also occur in right whale upcalls, but if other right whales are using acoustic cues from a distinctive signaler, those cues must propagate through the environment at least far enough to reach the receiver. Surely such distances will be farther than the distance from a whale's vocal apparatus to its own recording tag, and propagation testing will reveal to what extent such features are relevant for both conspecific receivers and passive acoustic monitoring.

Given the proposed context of the upcall as a long-distance contact call (Clark, 1982), any features used for recognition would need to be robust over long distances. It would be interesting to determine whether the time-frequency variables important for close-range discrimination, measured from Dtags in this study, are equally important at increasing distances. Charrier et al. (2009) conducted playback studies in different environments to test the propagation of mother fur seal reunion calls. The authors found that distance of recording differentially affected the propagation of relevant identity cues, degrading amplitude-related cues but retaining frequency cues with increasing distance. In the same study, Charrier et al. (2009) also measured propagation in different habitats and determined that the ambient noise of the habitat itself has an effect on the propagation of salient call features.

In different habitats, vocalizations of right whales may also be affected by changes in ambient noise (Parks et al., 2009). In a given year, North Atlantic right whales move through several different types of habitats with drastically different environments in terms of acoustic propagation, particularly whales that migrate to the calving grounds from high-latitude habitats (Parks et al., 2009). Parks et al. (2009) describe subtle variations in upcall parameters that correspond with differing noise profiles in three major habitat areas: Bay of Fundy, Cape Cod Bay, and the Southeast US. Duration, minimum frequency, and peak frequency showed variation among the three habitats, although the distributions of parameters for each habitat were largely

overlapping. The results of this thesis suggest that the distributions of measurements in Parks et al. (2009) may have been influenced by the presence of particular individuals in those habitats, although more ground-truthing would be necessary before such a conclusion were possible.

Implications for Monitoring

Marine passive acoustic monitoring (PAM) describes a system in which a recorder is used to collect acoustic information from a particular study site (Mellinger et al. 2007).

Recordings may come from manned recorders, such as a hydrophone towed behind a vessel, or unmanned, autonomous recorders. From a methodological standpoint, autonomous recorders are particularly useful in the marine environment since towed hydrophone deployments are limited by sea state, seasonal weather conditions, and travel distance to a study site (Au & Hastings, 2010).

With autonomously recorded data of stereotyped calls, unless information regarding age, sex, or identity can be extracted from the calls, there can be no further resolution of observation beyond a presence-absence assessment. One exception to this occurs if certain vocalizations are only produced by a particular age class or sex—e.g., song of humpback whales is only known to be produced by males (Payne & McVay, 1971). In the North Atlantic right whale, the broadband gunshot has only been recorded from adult males, and the tonal scream calls have thus far only been attributed to females (Parks et al., 2005; Parks et al., 2007). Seasonal occurrence of these vocalizations may indicate an increase in reproductive SAGs and the corresponding importance of the habitats in which these SAGs occur (Bort et al., 2015; Matthews et al., 2014). However, such vocalizations do not allow inference of presence or seasonal behavior of animals that do not

fit into the categories—i.e., one cannot conclude presence of females if the only vocalizations are known to be produced by males.

Thus, for monitoring purposes, the most information would be available when a stereotyped call is produced by all individuals and contains features that allow discrimination of individuals. The upcall of right whales is consistently reported as the most prevalent call in several passive acoustic monitoring studies, and it has often been used to confirm the presence of North Atlantic right whales in several habitats (Mellinger et al., 2007; Van Parijs et al., 2009; Mussoline et al., 2012; Bort et al., 2015). It is possible to use multiple autonomous or towed recorders to localize successive vocalizations and track an individual whale's movements within an area (e.g., (Urazghildiiev, 2014; Van Parijs et al., 2009). However, a major limitation of this technique becomes apparent when long periods of silence between bouts of calls prevent assignment of subsequent calls to a particular individual (discussed in Urazghildiiev, 2014).

Based on the results of this study, however, information is available within the upcall that can allow statistical determination of sex, age class, or individual identity. Furthermore, especially with multiple simultaneous recorders, deployment time is limited by battery life and available data storage space. The tradeoffs of these practical considerations often result in recorders with sample rates that are only sufficient to record the fundamental frequency of a call of interest—e.g., Mellinger et al. (2007) and Bort et al. (2015) were limited to sample rates of 2kHz for right whale monitoring. This study shows that even in the “low frequency” calls of the North Atlantic right whale, there may be additional discrimination possible if higher frequencies are included in autonomously recorded datasets. Identification of age class, sex, or individual identity using a single receiver may allow for longer deployments and higher sample rates.

APPENDIX A: ADDITIONAL TABLES

- Table 1: Descriptive statistics of variables by age, sex, and individual
- Table 2: Results from principal components analysis using all variables. Table indicates important variables, eigenvalues, and percent variance explained for the first three principal components
- Table 3: Results from principal components analysis using time-frequency and formant variables. Table indicates important variables, eigenvalues, and percent variance explained for the first three principal components
- Table 4: Results from principal components analysis using time-frequency and amplitude variables. Table indicates important variables, eigenvalues, and percent variance explained for the first three principal components
- Table 5: Results from principal components analysis using formant and amplitude variables. Table indicates important variables, eigenvalues, and percent variance explained for the first three principal components
- Table 6: Results from principal components analysis using time-frequency variables.
- Table 7: Results from principal components analysis using formant variables.
- Table 8: Results from principal components analysis using amplitude variables.
- Table 9: Results of stepwise DFA discriminating between age classes determined by reproductive maturity (N = 11 whales, 148 calls). Important variables are listed in the order in which they entered the analysis.
- Table 10: Results of stepwise DFA discriminating between age classes determined by approximate size (N=12 whales, 151 calls). Important variables are listed in the order in which they entered the analysis.
- Table 11: Results of stepwise DFA discriminating between sexes (N = 13 whales, 161 calls). Important variables are listed in the order in which they entered the analysis.
- Table 12: Results of stepwise DFA discriminating among individual whales (N=13 whales, 161 calls). Important variables are listed in the order in which they entered the analysis.
- Table 13: Results of CART analysis discriminating between age classes determined by reproductive maturity (N = 11 whales, 148 calls).
- Table 14: Results of CART analysis discriminating between age classes determined by approximate size (N = 12 whales, 151 calls).
- Table 15: Results of CART analysis discriminating between sexes (N = 13 whales, 161 calls).
- Table 16: Results of CART analysis discriminating among individuals (N = 13 whales, 161 calls).
- Table 17: Confusion matrix for DFA using all variables to classify calls to age classes determined by reproductive age.
- Table 18: Confusion matrix for DFA using all variables to classify calls to age classes determined by approximate size.
- Table 19: Confusion matrix for DFA using all variables to classify calls to sex
- Table 20: Confusion matrix for DFA using all variables to classify calls to individual.

Table 1: Descriptive statistics of variables by age, sex, and individual. All values are mean \pm SD.

Age (Reprod.)	Duration 90%		1 st frequency contour value		End frequency		18 th frequency contour value		Formant 3 Bandwidth	
Adult (N = 6)	0.87	\pm 0.22	110.41	\pm 30.17	204.08	\pm 49.25	118.70	\pm 86.80	848.18	\pm 139.76
Juvenile (N = 5)	0.56	\pm 0.21	103.13	\pm 26.70	185.00	\pm 59.59	32.50	\pm 67.48	779.37	\pm 136.97

Age (Size)	Duration 90%		1 st frequency contour value		End frequency		18 th frequency contour value	
Larger (N = 9)	0.85	\pm 0.21	108.05	\pm 28.85	208.36	\pm 52.87	102.03	\pm 90.95
Smaller (N = 3)	0.46	\pm 0.17	107.48	\pm 29.50	162.88	\pm 44.76	36.94	\pm 67.65

	25 th frequency contour value		Maximum amplitude, 4 th quartile		RMS amplitude, 4 th quartile	
Larger (N = 9)	27.28	\pm 71.10	0.12	\pm 0.09	0.04	\pm 0.02
Smaller (N = 3)	12.31	\pm 52.94	0.12	\pm 0.10	0.02	\pm 0.02

Table 1 (continued): Descriptive statistics of variables by age, sex, and individual. All values are mean \pm SD.

Sex	Duration 90%			1 st frequency contour value			End frequency		
Female (N = 8)	0.71	\pm	0.22	108.77	\pm	29.71	201.77	\pm	59.09
Male (N = 5)	0.79	\pm	0.27	106.80	\pm	27.62	196.31	\pm	50.18
	21 st frequency contour value			Formant 2			Formant 1 Bandwidth		
Female (N = 8)	22.39	\pm	64.24	1895.85	\pm	209.65	477.20	\pm	137.39
Male (N = 5)	83.36	\pm	91.46	2071.10	\pm	191.92	558.81	\pm	113.75
	Formant 3 Bandwidth			Formant 3:Formant 1			log(minimum amplitude), 2 nd quartile		
Female (N = 8)	886.48	\pm	142.71	3.25	\pm	0.51	-0.26	\pm	0.12
Male (N = 5)	796.28	\pm	133.09	3.23	\pm	0.75	-0.29	\pm	0.09

Table 1 (continued): Descriptive statistics of variables by age, sex, and individual. All values are mean \pm SD.

EGNO	Duration 90%	1st frequency contour value	End frequency	18 th frequency contour value	log(minimum amplitude), 3 rd quartile	RMS amplitude, 4 th quartile
2145	0.78 \pm 0.23	111.7 \pm 22.7	270.3 \pm 59.5	218.8 \pm 103.5	-0.2 \pm 0.2	0 \pm 0
2350	0.93 \pm 0.19	109.7 \pm 32.3	201.1 \pm 40.4	137.1 \pm 57.8	-0.3 \pm 0.1	0 \pm 0
3103	0.61 \pm 0.19	78.1 \pm 7.8	145.1 \pm 18.5	13.4 \pm 35.5	-0.2 \pm 0.1	0 \pm 0
3323	0.80 \pm 0.16	100.0 \pm 11.6	193.8 \pm 33.8	46.9 \pm 104.8	-0.3 \pm 0	0.1 \pm 0
1241	0.86 \pm 0.18	130.6 \pm 27.7	184.2 \pm 21.6	56.9 \pm 97.2	-0.3 \pm 0	0 \pm 0
2413	0.84 \pm 0.11	103.1 \pm 18.6	225.0 \pm 27.8	0.0 \pm 0.0	-0.3 \pm 0	0 \pm 0
3360	0.80 \pm 0.21	100.0 \pm 13.7	193.0 \pm 26.3	107.0 \pm 92.9	-0.3 \pm 0	0 \pm 0
3579	0.73 \pm 0.16	92.5 \pm 20.2	242.2 \pm 67.1	14.3 \pm 49.6	-0.3 \pm 0	0.1 \pm 0
3610	0.83 \pm 0.21	106.8 \pm 11.9	237.0 \pm 96.5	0.0 \pm 0.0	0 \pm 0	0 \pm 0
3101	0.50 \pm 0.08	115.2 \pm 25.8	205.1 \pm 54.3	0.0 \pm 0.0	-0.3 \pm 0	0.1 \pm 0
3442	0.41 \pm 0.12	107.3 \pm 16.7	153.9 \pm 29.9	41.1 \pm 71.2	-0.3 \pm 0	0 \pm 0
3430	0.47 \pm 0.29	177.1 \pm 19.7	273.4 \pm 28.2	59.9 \pm 103.7	-0.4 \pm 0	0 \pm 0
2123	0.55 \pm 0.08	95.1 \pm 25.9	131.5 \pm 16.7	0.0 \pm 0.0	-0.3 \pm 0.1	0.1 \pm 0

Table 2: Results from principal components analysis using all variables. Table indicates important variables, eigenvalues, and percent variance explained for the first three principal components

All variables	Total Number of Principal Components	13		
	% Variance Explained by all components	82.1		
Variables Strongly Correlated with First Three Principal Components				
	1	2	3	
Duration 90%	End frequency		RMS amplitude, 3rd quartile	
Duration	Maximum frequency		Maximum amplitude, 4th quartile	
17th frequency contour value	Minimum frequency		RMS amplitude, 4th quartile	
18th frequency contour value	Start frequency		log(minimum amplitude), 1st quartile	
19th frequency contour value	2nd frequency contour value		log(minimum amplitude), 2nd quartile	
20th frequency contour value	3rd frequency contour value		log(minimum amplitude), 3rd quartile	
21st frequency contour value	4th frequency contour value		log(minimum amplitude), 4th quartile	
22nd frequency contour value	5th frequency contour value			
23rd frequency contour value	6th frequency contour value			
24th frequency contour value				
25th frequency contour value				
26th frequency contour value				
6th frequency contour value				
8th frequency contour value				
Formant 2:Formant 1				
Maximum amplitude, 2nd quartile				
RMS amplitude, 2nd quartile				
Maximum amplitude, 3rd quartile				
RMS amplitude, 3rd quartile				
Maximum amplitude, 4th quartile				
Eigenvalues	10.7	7.5	6.7	
% Variance	18.1	12.8	11.3	
Cumulative	18.1	30.8	42.2	

Table 3: Results from principal components analysis using time-frequency and formant variables. Table indicates important variables, eigenvalues, and percent variance explained for the first three principal components

Time-frequency + formants	Total Number of Principal Components	10		
	% Variance Explained by all components	79.3		
Variables Strongly Correlated with First Three Principal Components				
	1	2	3	
Duration 90%		End frequency	12th frequency contour value	
Duration		Maximum frequency	13th frequency contour value	
17th frequency contour value		Minimum frequency	14th frequency contour value	
18th frequency contour value		Start frequency	15th frequency contour value	
19th frequency contour value		2nd frequency contour value	16th frequency contour value	
20th frequency contour value		3rd frequency contour value		
21st frequency contour value		4th frequency contour value		
22nd frequency contour value		5th frequency contour value		
23rd frequency contour value		6th frequency contour value		
24th frequency contour value		7th frequency contour value		
25th frequency contour value		8th frequency contour value		
26th frequency contour value				
27th frequency contour value				
28th frequency contour value				
8th frequency contour value				
Eigenvalues	9.54	7.273	5.11	
% of Variance	20.299	15.475	10.873	
Cumulative %	20.299	35.774	46.647	

Table 4: Results from principal components analysis using time-frequency and amplitude variables. Table indicates important variables, eigenvalues, and percent variance explained for the first three principal components

Time-frequency + amplitude	Total Number of Principal Components		
	9		
% Variance Explained by all components			
79.4			
Variables Strongly Correlated with First Three Principal Components			
	1	2	3
Duration 90%		End frequency	Maximum amplitude, 2nd quartile
Duration		Maximum frequency	RMS amplitude, 2nd quartile
18th frequency contour value		Minimum frequency	Maximum amplitude, 3rd quartile
19th frequency contour value		Start frequency	RMS amplitude, 3rd quartile
20th frequency contour value		2nd frequency contour value	Maximum amplitude, 4th quartile
21st frequency contour value		3rd frequency contour value	RMS amplitude, 4th quartile
22nd frequency contour value		4th frequency contour value	log(minimum amplitude), 1st quartile
23rd frequency contour value		5th frequency contour value	log(minimum amplitude), 2nd quartile
24th frequency contour value		6th frequency contour value	log(minimum amplitude), 3rd quartile
25th frequency contour value			log(minimum amplitude), 4th quartile
26th frequency contour value			
8th frequency contour value			
Maximum amplitude, 2nd quartile			
RMS amplitude, 2nd quartile			
Maximum amplitude, 3rd quartile			
RMS amplitude, 3rd quartile			
Maximum amplitude, 4th quartile			
Eigenvalues	10.106	7.488	6.618
% of Variance	20.212	14.976	13.235
Cumulative %	20.212	35.188	48.423

Table 5: Results from principal components analysis using formant and amplitude variables. Table indicates important variables, eigenvalues, and percent variance explained for the first three principal components

Formant + amplitude	Total Number of Principal Components	6		
	% Variance Explained by all components	84.9		
Variables Strongly Correlated with First Three Principal Components				
	1	2	3	
Maximum amplitude, 2nd quartile		Formant 1	log(minimum amplitude), 4th quartile	
Maximum amplitude, 3rd quartile		Formant 2	log(minimum amplitude), 3rd quartile	
RMS amplitude, 3rd quartile		Formant 3:Formant 1	log(minimum amplitude), 2nd quartile	
RMS amplitude, 2nd quartile		Formant 3:Formant 2	Formant 2:Formant 1	
log(minimum amplitude), 4th quartile		Formant 2:Formant 1	Formant 3	
log(minimum amplitude), 3rd quartile		Formant 3		
Maximum amplitude, 1st quartile				
log(minimum amplitude), 2nd quartile				
RMS amplitude, 1st quartile				
<hr/>				
Eigenvalues	7.615	4.026	2.228	
% of Variance	36.262	19.17	10.608	
Cumulative %	36.262	55.432	66.039	

Table 6: Results from principal components analysis using time-frequency variables. Table indicates important variables, eigenvalues, and percent variance explained for the first three principal components

Time-frequency	Total Number of Principal Components		
	7		
	% Variance Explained by all components		
	78.2		
Variables Strongly Correlated with First Three Principal Components			
	1	2	3
Duration 90%		End frequency	12th frequency contour value
Duration		Maximum frequency	13th frequency contour value
17th frequency contour value		Minimum frequency	14th frequency contour value
18th frequency contour value		Start frequency	15th frequency contour value
19th frequency contour value		2nd frequency contour value	16th frequency contour value
20th frequency contour value		3rd frequency contour value	28th frequency contour value
21st frequency contour value		4th frequency contour value	29th frequency contour value
22nd frequency contour value		5th frequency contour value	30th frequency contour value
23rd frequency contour value		6th frequency contour value	
24th frequency contour value		7th frequency contour value	
25th frequency contour value		8th frequency contour value	
26th frequency contour value			
27th frequency contour value			
28th frequency contour value			
8th frequency contour value			
Eigenvalues	9.1	7.2	4.8
% of Variance	24.0	19.0	12.6
Cumulative %	24.0	43.0	55.6

Table 7: Results from principal components analysis using formant variables. Table indicates important variables, eigenvalues, and percent variance explained for the first three principal components

Formant	Total Number of Principal Components		
	3		
	% Variance Explained by all components		
	77.6		
Variables Strongly Correlated with First Three Principal Components			
	1	2	3
Formant 1		Formant 2:Formant 1	Formant 3 Bandwidth
Formant 1 Bandwidth		Formant 3	Formant 3:Formant 2
Formant 2			
Formant 2:Formant 1			
Formant 3			
Formant 3:Formant 1			
Formant 3:Formant 2			
Eigenvalues	4.0	1.6	1.4
% of Variance	44.7	17.3	15.6
Cumulative %	44.7	62.0	77.6

Table 8: Results from principal components analysis using amplitude variables. Table indicates important variables, eigenvalues, and percent variance explained for the first three principal components

Amplitude	Total Number of Principal Components			3
	% Variance Explained by all components			88.7
Variables Strongly Correlated with First Three Principal Components				
	1	2	3	
Maximum amplitude, 1st quartile		log(minimum amplitude), 1st quartile	Maximum amplitude, 1st quartile	
RMS amplitude, 1st quartile		log(minimum amplitude), 2nd quartile	RMS amplitude, 1st quartile	
Maximum amplitude, 2nd quartile		log(minimum amplitude), 3rd quartile		
RMS amplitude, 2nd quartile		log(minimum amplitude), 4th quartile		
Maximum amplitude, 3rd quartile				
RMS amplitude, 3rd quartile				
Maximum amplitude, 4th quartile				
RMS amplitude, 4th quartile				
log(minimum amplitude), 1st quartile				
log(minimum amplitude), 2nd quartile				
log(minimum amplitude), 3rd quartile				
log(minimum amplitude), 4th quartile				
Eigenvalues	7.3	2.1	1.2	
% of Variance	60.7	17.8	10.2	
Cumulative %	60.7	78.5	88.7	

Table 9: Results of stepwise DFA discriminating between age classes determined by reproductive maturity (N = 11 whales, 148 calls). Important variables are listed in the order in which they entered the analysis.

Variable Grouping	% Correct Classification	Important Variables
Formants	77	Formant 1 Formant 3 Bandwidth** Formant 3:Formant 2
Amplitude	81.1	Maximum amplitude, 3rd quartile RMS amplitude, 1st quartile RMS amplitude, 3rd quartile log(minimum amplitude), 4th quartile log(minimum amplitude), 3rd quartile
Time-frequency	81.1	Duration 90% ** 18th frequency contour value** 9th frequency contour value
Time-frequency + formants	80.4	Duration 90% ** 18th frequency contour value** Formant 3 Bandwidth** Formant 2 Bandwidth
Time-frequency + amplitude	82.4	Duration 90% ** 18th frequency contour value** 9th frequency contour value log(minimum amplitude), 4th quartile log(minimum amplitude), 1st quartile
Formants + amplitude	85.1	Maximum amplitude, 3rd quartile RMS amplitude, 1st quartile Q3normRMS Formant 1 Formant 3:Formant 2 Formant 3 Bandwidth**
All	80.4	Duration 90% ** 18th frequency contour value** Formant 3 Bandwidth** Formant 2 Bandwidth

* variables which were used in 3 of 4 analyses for a given variable grouping

** variables used in all analyses for a given variable grouping

Table 10: Results of stepwise DFA discriminating between age classes determined by approximate size (N=12 whales, 151 calls). Important variables are listed in the order in which they entered the analysis.

Variable Grouping	% Correct Classification	Important Variables
Formants	78.1	Formant 2:Formant 1
Amplitude	91.4	log(minimum amplitude), 4th quartile RMS amplitude, 4th quartile** Maximum amplitude, 4th quartile** Maximum amplitude, 3rd quartile RMS amplitude, 1st quartile RMS amplitude, 2nd quartile
Time-frequency	92.1	Duration 90%** End frequency** 25th frequency contour value** 20th frequency contour value 31st frequency contour value
Time-frequency + formants	92.7	Duration 90%** End frequency** 25th frequency contour value** 20th frequency contour value Formant 1 Bandwidth
Time-frequency + amplitude	94	Duration 90%** RMS amplitude, 4th quartile** Maximum amplitude, 4th quartile** End frequency** 25th frequency contour value** log(minimum amplitude), 1st quartile log(minimum amplitude), 3rd quartile
Formants + amplitude	91.4	log(minimum amplitude), 4th quartile RMS amplitude, 4th quartile** Maximum amplitude, 4th quartile** Maximum amplitude, 3rd quartile RMS amplitude, 1st quartile RMS amplitude, 2nd quartile
All	94	Duration 90%** RMS amplitude, 4th quartile** Maximum amplitude, 4th quartile** End frequency** 25th frequency contour value** log(minimum amplitude), 1st quartile log(minimum amplitude), 3rd quartile

*variables which were used in 3 of 4 analyses for a given variable grouping

**variables used in all analyses for a given variable grouping

Table 11: Results of stepwise DFA discriminating between sexes (N = 13 whales, 161 calls). Important variables are listed in the order in which they entered the analysis.

Variable Grouping	% Correct Classification	Important Variables
Formants	79.5	Formant 2** Formant 3 Bandwidth** Formant 1 Bandwidth** Formant 3:Formant 1**
Amplitude	70.2	Maximum amplitude, 2nd quartile* log(minimum amplitude), 2nd quartile**
Time-frequency	74.1	21st frequency contour value** 13th frequency contour value*
Time-frequency + formants	80.1	Formant 2** 21st frequency contour value** Formant 3 Bandwidth** Formant 1 Bandwidth** 7th frequency contour value 13th frequency contour value* PFC15 Formant 3:Formant 1**
Time-frequency + amplitude	74.5	21st frequency contour value** log(minimum amplitude), 2nd quartile** Maximum amplitude, 2nd quartile*
Formants + amplitude	83.9	Formant 2** Formant 3 Bandwidth** Maximum amplitude, 3rd quartile log(minimum amplitude), 2nd quartile** Formant 1 Bandwidth** Formant 3:Formant 1**
All	83.2	Formant 2** 21st frequency contour value** Formant 3 Bandwidth** Formant 1 Bandwidth** 7th frequency contour value Maximum amplitude, 2nd quartile* log(minimum amplitude), 2nd quartile** Formant 3:Formant 1** 13th frequency contour value* 14th frequency contour value

* variables which were used in 3 of 4 analyses for a given variable grouping

** variables used in all analyses for a given variable grouping

Table 12: Results of stepwise DFA discriminating among individual whales (N=13 whales, 161 calls). Important variables are listed in the order in which they entered the analysis.

Variable Grouping	% Correct Classification	Important Variables
Formants	42.2	Formant 2* Formant 1
Amplitude	60.9	Maximum amplitude, 3rd quartile* RMS amplitude, 4th quartile** log(minimum amplitude), 3rd quartile** RMS amplitude, 3rd quartile RMS amplitude, 1st quartile
Time-frequency	67.7	Duration 90%** 18th frequency contour value** End frequency 21st frequency contour value*
Time-frequency + formants	72.0	Duration 90%** 18th frequency contour value** Duration Formant 2* 9th frequency contour value End frequency
Time-frequency + amplitude	79.5	Duration 90%** RMS amplitude, 4th quartile** log(minimum amplitude), 3rd quartile** 8th frequency contour value 18th frequency contour value** Maximum amplitude, 3rd quartile* RMS amplitude, 2nd quartile 21st frequency contour value*
Formants + amplitude	57.8	Maximum amplitude, 3rd quartile* RMS amplitude, 4th quartile** Formant 2 log(minimum amplitude), 3rd quartile** RMS amplitude, 3rd quartile
All	83.2	Duration 90%** RMS amplitude, 4th quartile** 18th frequency contour value** Formant 1 Bandwidth log(minimum amplitude), 3rd quartile** 21st frequency contour value*

* variables which were used in 3 of 4 analyses for a given variable grouping

** variables used in all analyses for a given variable grouping

Table 13: Results of CART analysis discriminating between age classes determined by reproductive maturity (N = 11 whales, 148 calls).

Variable grouping	Number of Splits	% Correct Classifications	Variable at First Split	Variables Used in Tree
Formants	4	89.2	Formant 1	Formant 1** Formant 1 Bandwidth Formant 3 Bandwidth** Formant 3:Formant 2
Amplitude	5	89.2	log(minimum amplitude), 4th quartile	log(minimum amplitude), 1st quartile log(minimum amplitude), 4th quartile* Maximum amplitude, 3rd quartile** RMS amplitude, 1st quartile* RMS amplitude, 4th quartile
Time-frequency	4	85.8	Duration 90%**	10th frequency contour value Duration Duration 90% Start frequency
Time-frequency + formants	4	91.2	Duration 90%**	Duration Duration 90% Formant 1** Formant 3 Bandwidth**
Time-frequency + amplitude	5	90.5	Duration 90%**	Duration 90% log(minimum amplitude), 4th quartile* Maximum amplitude, 2nd quartile Maximum amplitude, 3rd quartile** RMS amplitude, 1st quartile*
Formant + Amplitude	5	91.9	log(minimum amplitude), 4th quartile	Formant 3 Bandwidth** Formant 1** Maximum amplitude, 3rd quartile** RMS amplitude, 4th quartile log(minimum amplitude), 4th quartile*
All	7	94.6	Duration 90%**	Duration 90% Formant 1** Formant 3 Bandwidth** log(minimum amplitude), 2nd quartile Maximum amplitude, 3rd quartile** Maximum frequency
DFA Variables	6	90.5	Duration 90%	18th frequency contour value Duration 90% Formant 1 Bandwidth RMS amplitude, 1st quartile*

* variables which were used in 3 of 4 analyses for a given variable grouping

** variables used in all analyses for a given variable grouping

Table 14: Results of CART analysis discriminating between age classes determined by approximate size (N = 12 whales, 151 calls).

Variable grouping	Number of Splits	% Correct Classifications	Variable at First Split	Variables Used in Tree
Formants	8	90.7	Formant 1	Formant 1 Bandwidth Formant 2 Bandwidth Formant 3 Bandwidth Formant 1 Formant 2:Formant 1 Formant 3 Formant 3:Formant 2
Amplitude	3	91.4	log(minimum amplitude), 4th quartile	RMS amplitude, 4th quartile log(minimum amplitude), 1st quartile log(minimum amplitude), 4th quartile
Time-frequency	1	89.4	Duration 90%**	Duration 90%
Time-frequency + formants	2	92.1	Duration 90%**	Duration 90% Maximum frequency
Time-frequency + amplitude	1	89.4	Duration 90%**	Duration 90%
Formants + amplitude	3	91.4	log(minimum amplitude), 4th quartile	RMS amplitude, 4th quartile log(minimum amplitude), 1st quartile log(minimum amplitude), 4th quartile
All	1	89.4	Duration 90%**	Duration 90%
DFA Variables	6	94.7	Duration 90%**	Duration 90% Formant 1 Bandwidth 18th frequency contour value RMS amplitude, 4th quartile

* variables which were used in 3 of 4 analyses for a given variable grouping

** variables used in all analyses for a given variable grouping

Table 15: Results of CART analysis discriminating between sexes (N = 13 whales, 161 calls).

Variable Grouping	Number of Splits	% Correct Classifications	Variable at First Split	Variables Used in Tree
Formants	1	75.8	Formant 2**	Formant 2**
Amplitude	4	83.2	Maximum amplitude, 2nd quartile	Maximum amplitude, 2nd quartile Maximum amplitude, 3rd quartile RMS amplitude, 4th quartile
Time-frequency	2	72.7	21st frequency contour value	18th frequency contour value 21st frequency contour value
Time-frequency + formants	2	79.5	Formant 2**	9th frequency contour value Formant 2**
Time-frequency + amplitude	11	93.2	Maximum amplitude, 2nd quartile	13th frequency contour value 14th frequency contour value 17th frequency contour value 9th frequency contour value Maximum amplitude, 2nd quartile Maximum amplitude, 3rd quartile Maximum frequency RMS amplitude, 3rd quartile
Formant + Amplitude	1	75.8	Formant 2**	Formant 2**
All	1	75.8	Formant 2**	Formant 2**
DFA Variables	10	92.5	Maximum amplitude, 2nd quartile	Formant 1 Bandwidth 18th frequency contour value Maximum amplitude, 2nd quartile RMS amplitude, 4th quartile log(minimum amplitude), 3rd quartile

* variables which were used in 3 of 4 analyses for a given variable grouping

** variables used in all analyses for a given variable grouping

Table 16: Results of CART analysis discriminating among individuals (N = 13 whales, 161 calls).

Variable Grouping	Number of Splits	% Correct Classifications	Variable at First Split	Variables Used in Tree
Formants	8	61.5	Formant 2:Formant 1	Formant 1 Formant 1 Bandwidth Formant 2:Formant 1 Formant 3 Bandwidth
Amplitude	5	62.1	Maximum amplitude, 3rd quartile	log(minimum amplitude), 1st quartile log(minimum amplitude), 2nd quartile* Maximum amplitude, 3rd quartile RMS amplitude, 3rd quartile** RMS amplitude, 4th quartile**
Time-frequency	4	61.5	19th frequency contour value**	10th frequency contour value 15th frequency contour value* 19th frequency contour value** Duration 90% **
Time-frequency + formants	3	58.4	19th frequency contour value**	10th frequency contour value 19th frequency contour value** Duration 90% **
Time-frequency + amplitude	16	83.9	19th frequency contour value**	12th frequency contour value 15th frequency contour value* 16th frequency contour value 19th frequency contour value** Duration Duration 90% ** Maximum amplitude, 1st quartile Maximum amplitude, 2nd quartile Maximum amplitude, 4th quartile Maximum frequency RMS amplitude, 3rd quartile** RMS amplitude, 4th quartile**

Table 16 (cont'd): Results of CART analysis discriminating among individuals (N = 13 whales, 161 calls).

Variable Grouping	Number of Splits	% Correct Classifications	Variable at First Split	Variables Used in Tree
Formant + Amplitude	6	64.6	Maximum amplitude, 3rd quartile	Formant 3:Formant 2 Maximum amplitude, 3rd quartile RMS amplitude, 3rd quartile** RMS amplitude, 4th quartile** log(minimum amplitude), 1st quartile log(minimum amplitude), 2nd quartile*
All	18	86.3	19th frequency contour value**	15th frequency contour value* 16th frequency contour value 19th frequency contour value** 2nd frequency contour value Duration Duration 90%** End frequency Formant 1 Formant 2 log(minimum amplitude), 2nd quartile* Maximum amplitude, 2nd quartile Maximum amplitude, 4th quartile Maximum frequency RMS amplitude, 3rd quartile** RMS amplitude, 4th quartile**
DFA Variables	12	73.3	Duration 90%	18th frequency contour value 21st frequency contour value Duration 90% Formant 1 Bandwidth log(minimum amplitude), 3rd quartile Maximum amplitude, 2nd quartile RMS amplitude, 1st quartile RMS amplitude, 2nd quartile RMS amplitude, 4th quartile

* variables which were used in 3 of 4 analyses for a given variable grouping

** variables used in all analyses for a given variable grouping

Table 17: Confusion matrix for DFA using formant and amplitude variables to classify calls to age class based on reproductive maturity. Rows indicate the actual (original) age class, and columns indicate the predicted age class. Values in each cell represent the total number of calls assigned to a particular age class, with numbers on the diagonal representing correct classifications.

		Predicted Group Membership		
		Adult	Juvenile	Total
Original Group Membership	Adult	93	5	98
	Juvenile	17	33	50

Table 18: Confusion matrix for DFA using time-frequency and amplitude variables to classify calls to age class based on approximate size. Rows indicate the actual (original) age class, and columns indicate the predicted age class. Values in each cell represent the total number of calls assigned to a particular age class, with numbers on the diagonal representing correct classifications.

		Predicted Group Membership		
		Small	Large	Total
Original Group Membership	Small	27	6	33
	Large	3	115	118

Table 19: Confusion matrix for DFA using formant and amplitude variables to classify calls to age class based on approximate size. Rows indicate the actual (original) age class, and columns indicate the predicted age class. Values in each cell represent the total number of calls assigned to a particular age class, with numbers on the diagonal representing correct classifications.

		Predicted Group Membership		
		Male	Female	Total
Original Group Membership	Male	103	6	109
	Female	20	32	52

Table 20: Confusion matrix for DFA using all variables to classify calls to individual. Rows indicate the actual (original) catalog number, and columns indicate the predicted catalog number. Values in each cell represent the total number of calls assigned to a particular individual, with numbers on the diagonal representing correct classifications.

		Predicted Group Membership												Total	
		2145	2350	3103	3323	1241	2413	3360	3579	3610	3101	3442	3430		2123
Original Group Membership	2145	6	2	0	1	0	0	0	0	1	0	0	0	0	10
	2350	2	62	0	0	1	0	0	0	0	0	1	0	0	66
	3103	0	0	4	0	1	0	0	0	0	0	0	0	2	7
	3323	0	0	0	4	0	1	0	0	0	0	0	0	0	5
	1241	1	0	0	0	5	0	0	0	0	0	0	0	1	7
	2413	0	0	0	0	0	5	0	0	0	0	0	0	0	5
	3360	0	1	0	0	0	0	8	0	0	0	1	0	0	10
	3579	0	1	0	1	0	0	0	10	0	0	0	0	0	12
	3610	0	0	0	0	0	0	0	0	3	0	0	0	0	3
	3101	0	0	1	0	0	0	0	1	0	1	0	1	0	4
	3442	0	2	0	0	0	0	0	0	0	0	21	0	0	23
	3430	0	0	0	0	0	0	0	0	0	0	0	3	0	3
	2123	0	0	0	2	0	0	0	0	1	0	1	0	2	6

APPENDIX B: ADDITIONAL FIGURES

- Figure 1: Scatterplot matrix of first three principal component scores of the PCA using time-frequency and formant variables showing grouping by reproductive age.
- Figure 2: Scatterplot matrix of first three principal component scores of the PCA using time-frequency and formant variables showing grouping by size-based age.
- Figure 3: Scatterplot matrix of first three principal component scores of the PCA using formant and amplitude variables showing grouping by sex.
- Figure 4: Canonical discriminant scores for one discriminant function using formant and amplitude variables to discriminate between age classes based on reproductive age.
- Figure 5: Canonical discriminant scores for one discriminant function using time-frequency and amplitude variables to discriminate between age classes based on approximate size.
- Figure 6: Canonical discriminant scores for one discriminant function using formant and amplitude variables to discriminate between sexes.
- Figure 7: Classification tree using all variables to classify calls to an age category based on reproductive age.
- Figure 8: Classification tree using all variables to classify calls to an age category based on approximate size.
- Figure 9: Classification tree using time-frequency and amplitude variables to classify calls by sex.



Figure 1: Scatterplot matrix of first three principal component scores of the PCA using time-frequency and formant variables showing grouping by reproductive age. The first three components explained 46.6% of the variation in the data, and all 10 components in the analysis explained 79.3%. Colors indicate age based on reproductive status (adult, juvenile), and lines are drawn from each call to the group centroid of principal component scores for that category.

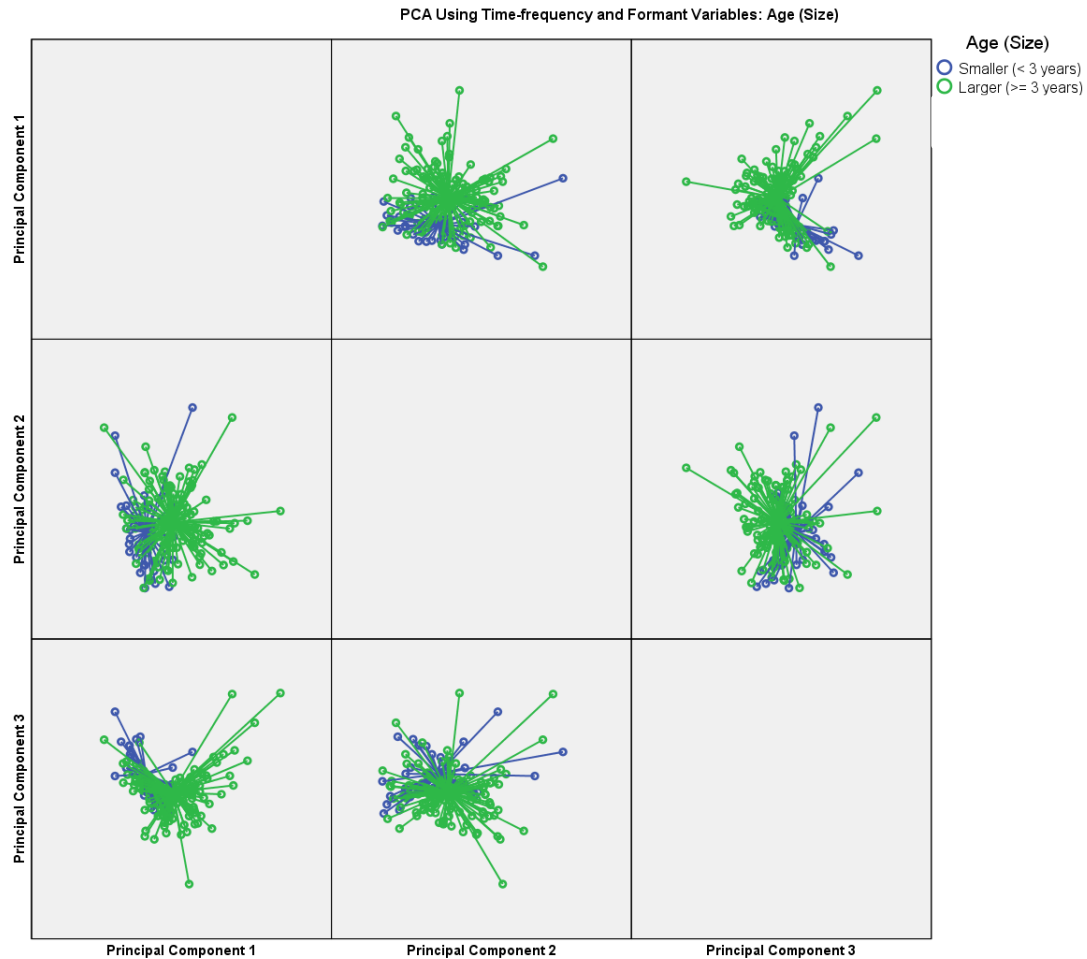

Figure 2: Scatterplot matrix of first three principal component scores of the PCA using time-frequency and formant variables showing grouping by size-based age. The first three components explained 46.6% of the variation in the data, and all 10 components in the analysis explained 79.3%. Colors indicate age based on approximate size (adult, juvenile), and lines are drawn from each call to the group centroid of principal component scores for that category.



Figure 3: Scatterplot matrix of first three principal component scores of the PCA using formant and amplitude variables showing grouping by sex. The first three components explained 66.0% of the variation in the data, and all 6 components in the analysis explained 84.9%. Colors indicate sex (male, female), and lines are drawn from each call to the group centroid of principal component scores for that category.

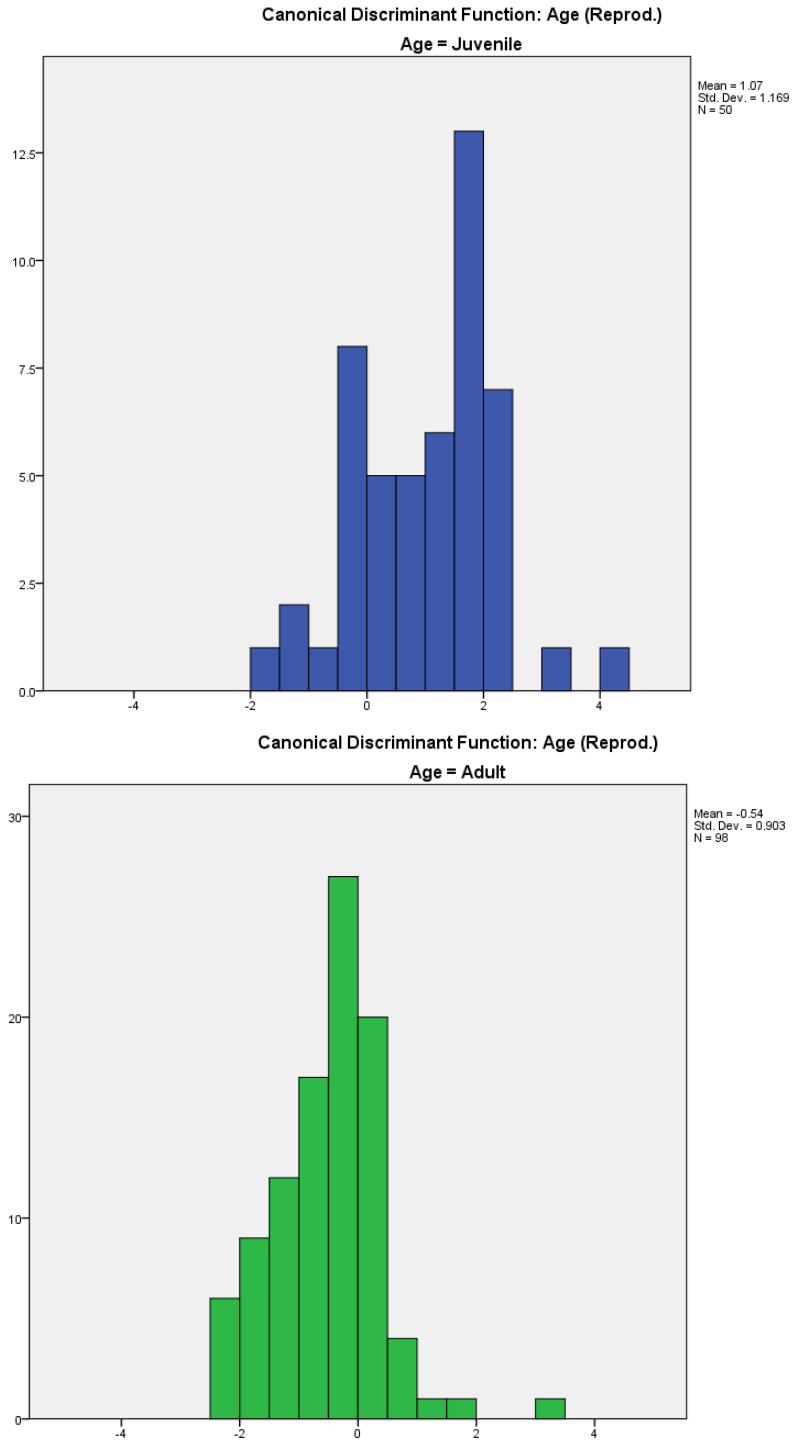

Figure 4: Canonical discriminant scores for one discriminant function using formant and amplitude variables to discriminate between age classes based on reproductive age. Correct classification based on this function was 85.1%. The number of calls as well as the mean and standard deviation for the discriminant scores of each category are provided.

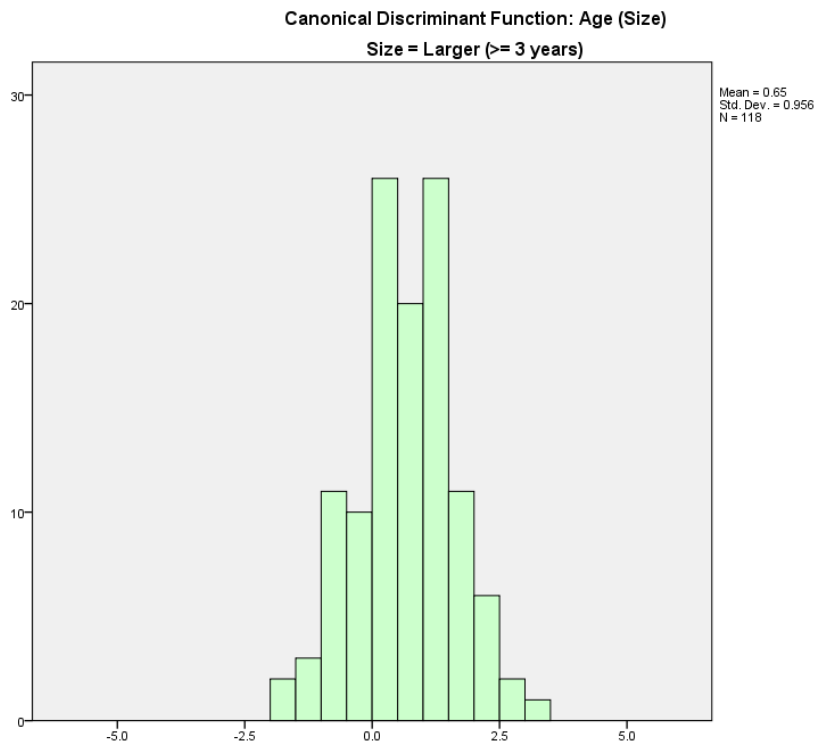
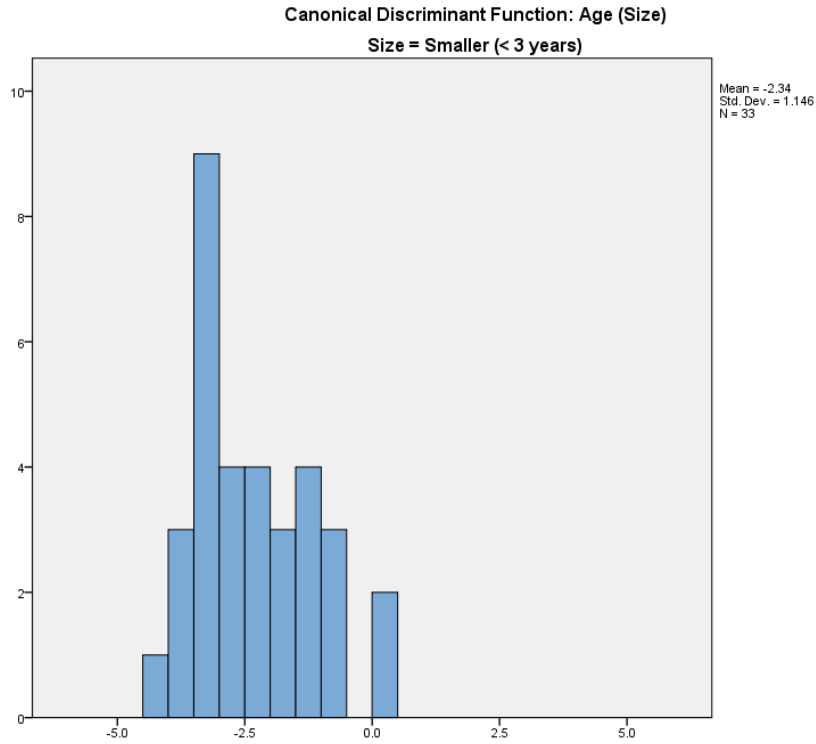

Figure 5: Canonical discriminant scores for one discriminant function using time-frequency and amplitude variables to discriminate between age classes based on approximate size. Correct classification based on this function was 94.0%. The number of calls as well as the mean and standard deviation for the discriminant scores of each category are provided.

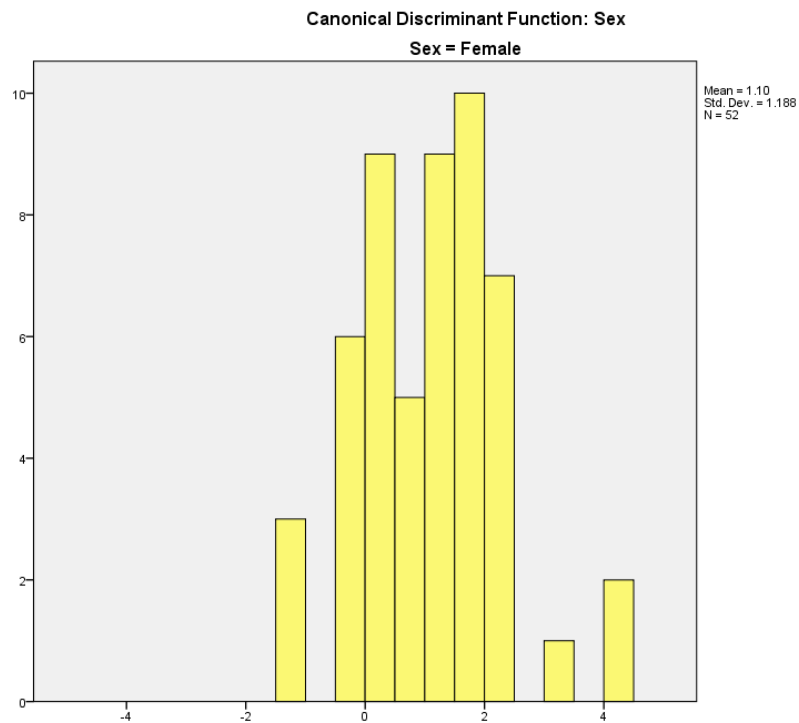
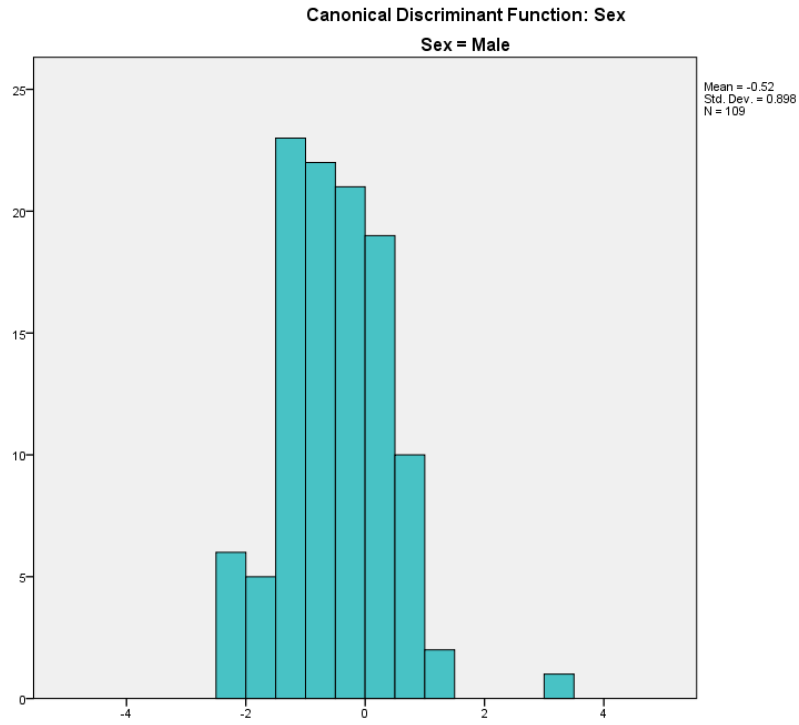

Figure 6: Canonical discriminant scores for one discriminant function using formant and amplitude variables to discriminate between sexes. Correct classification based on this function was 83.9%. The number of calls as well as the mean and standard deviation for the discriminant scores of each category are provided.

Age (Reprod.): Pruned Tree Using All Variables

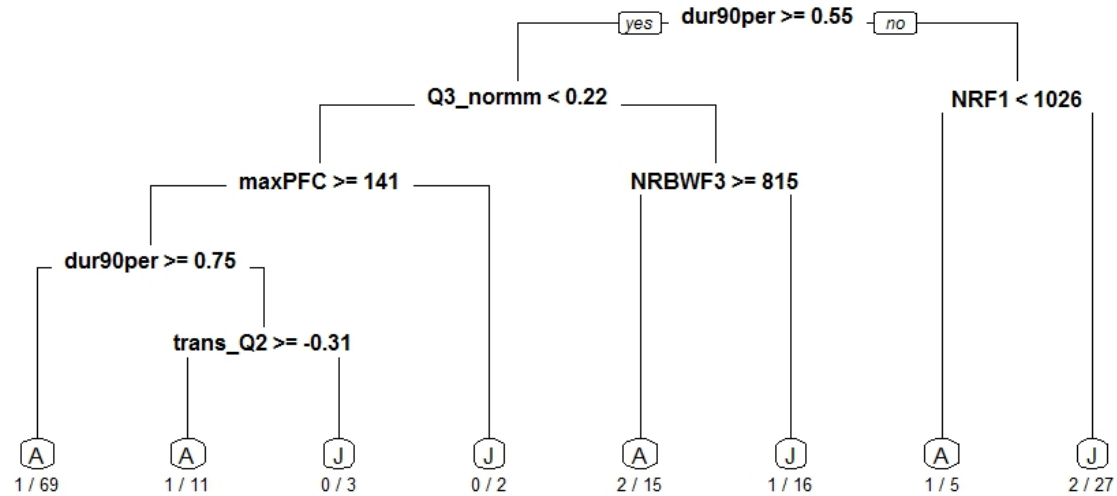

Figure 7: Classification tree using all variables to classify calls to an age category based on reproductive age. Branches displayed to the left of a split contain cases which satisfy the criterion defined at each split. Terminal nodes are labeled with the age category (A = adult, J = juvenile) with the majority of calls assigned to that node. Overall percentage of correct classification was 94.6%. The classification success of each node is listed as misclassifications/total number of calls.

Age (Size): Pruned Tree Using Important Variables from Stepwise DFA

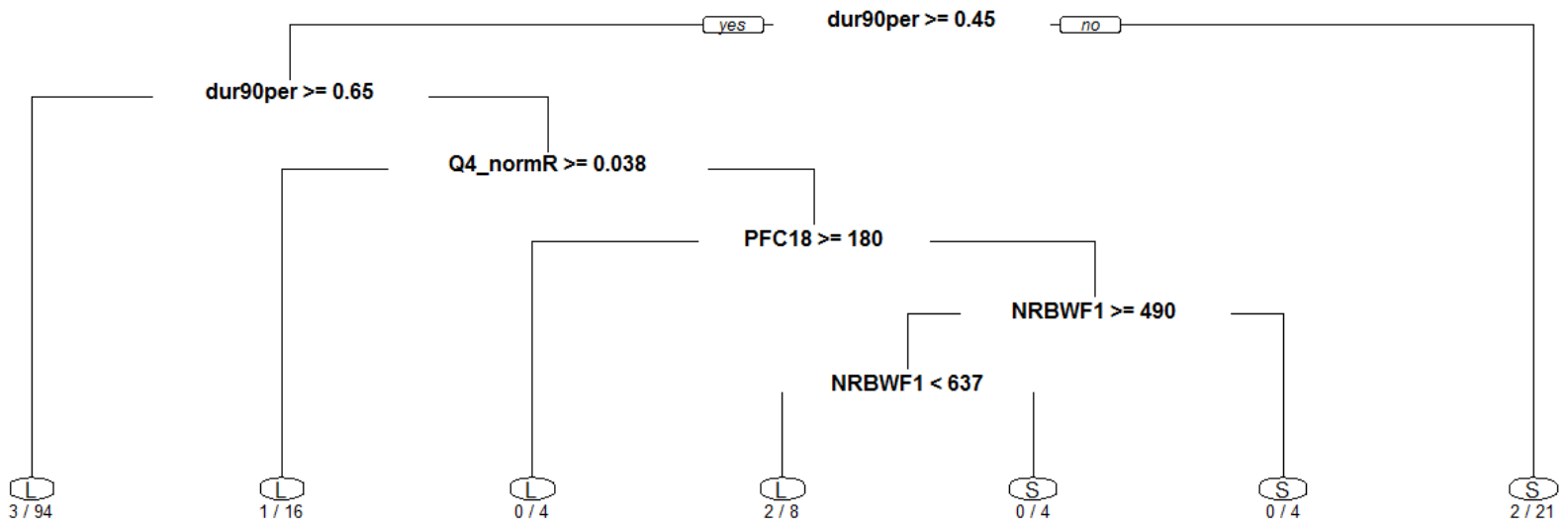

Figure 8: Classification tree using all variables to classify calls to an age category based on approximate size. Branches displayed to the left of a split contain cases which satisfy the criterion defined at each split. Terminal nodes are labeled with the age category (L = large ≥ 3 years of age), S = small < 3 years of age) with the majority of calls assigned to that node. Overall percentage of correct classification was 94.7%. The classification success of each node is listed as misclassifications/total number of calls.

Sex: Pruned Tree Using Time-frequency + Amplitude Variables

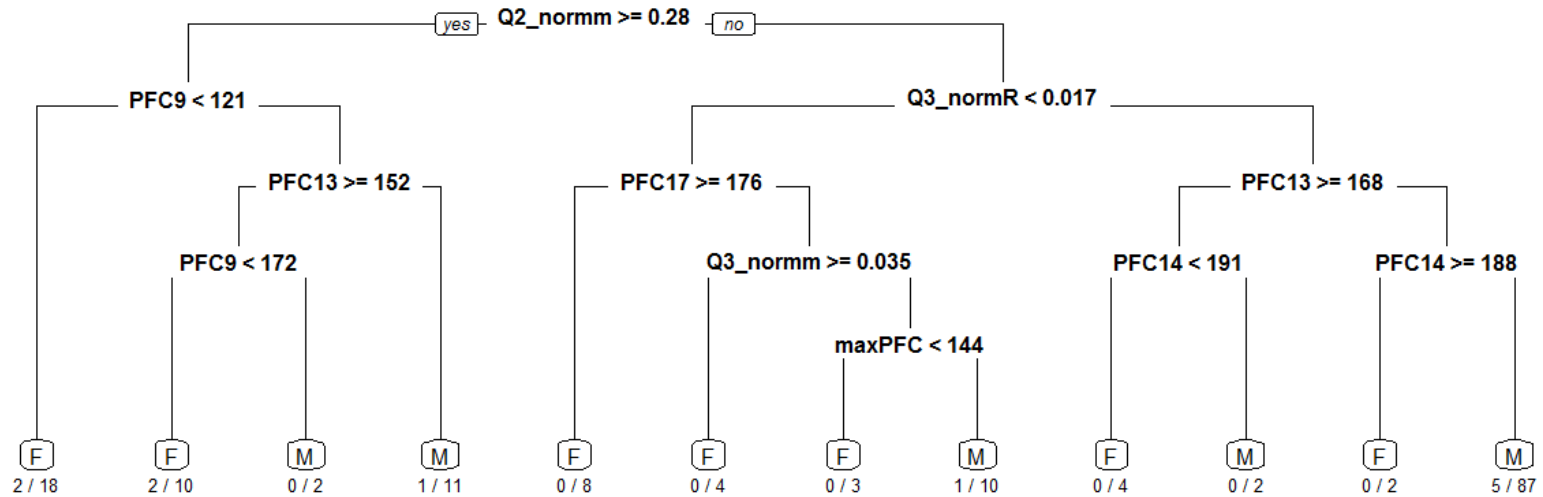

Figure 9: Classification tree using time-frequency and amplitude variables to classify calls by sex. Branches displayed to the left of a split contain cases which satisfy the criterion defined at each split. Terminal nodes are labeled with the age category (M = male, F = female) with the majority of calls assigned to that node. Overall percentage of correct classification was 93.2%. The classification success of each node is listed as misclassifications/total number of calls.

LITERATURE CITED

- Adam, O., Cazau, D., Gandilhon, N., Fabre, B., Laitman, J.T. & Reidenberg, J.S. (2013). New acoustic model for humpback whale sound production. *Applied Acoustics* 74(10): 1182–1190.
- Adobe Systems Incorporated. (2007). Adobe Audition 3.0. San Jose, CA.
- Aiello, L.C. & Wheeler, P. (1995). The expensive-tissue hypothesis: the brain and the digestive system in human and primate evolution. *Current Anthropology* 36(2): 199.
- Au, W.W.L. & Hastings, M.C. (2010). *Principles of Marine Bioacoustics*. New York, NY: Springer Science+Business Media, LLC.
- Aubin, T., Jouventin, P. & Hildebrand, C. (2000). Penguins use the two-voice system to recognize each other. *Proceedings of the Royal Society B: Biological Sciences* 267: 1081–1087.
- Avisoft Bioacoustics. (2013). AviSoft SASLab Pro: Sound Analysis and Synthesis Laboratory. Glienicke, Germany.
- Bachorowski, J.A. & Owren, M.J. (1999). Acoustic correlates of talker sex and individual talker identity are present in a short vowel segment produced in running speech. *The Journal of the Acoustical Society of America* 106(2): 1054–1063.
- Bioacoustics Research Program. (2014). Raven Pro: Interactive Sound Analysis Software. Ithaca, NY: The Cornell Lab of Ornithology. Retrieved from <http://www.birds.cornell.edu/raven>
- Blumstein, D.T. & Armitage, K.B. (1997). Does sociality drive the evolution of communicative complexity? A comparative test with ground-dwelling sciurid alarm calls. *The American naturalist* 150(2): 179–200.
- Blumstein, D.T. & Munos, O. (2005). Individual, age and sex-specific information is contained in yellow-bellied marmot alarm calls. *Animal Behaviour* 69: 353–361.
- Boersma, P. & Weenik, D. (2012). Praat: doing phonetics by computer. Retrieved from www.praat.org
- Bort, J., Van Parijs, S., Stevick, P., Summers, E. & Todd, S. (2015). North Atlantic right whale *Eubalaena glacialis* vocalization patterns in the central Gulf of Maine from October 2009 through October 2010. *Endangered Species Research* 26: 271–280.
- Boughman, J.W. (1997). Greater spear-nosed bats give group-distinctive calls. *Behavioral Ecology and Sociobiology* 40(1): 61–70.

- Bradbury, J.W. & Vehrencamp, S.L. (2011). *Principles of Animal Communication* (Second Ed.). Sunderland, MA: Sinauer Associates, Inc.
- Brown, M., Kraus, S., Gaskin, D. & White, B. (1994). Sexual composition and analysis of reproductive females in the North Atlantic right whale, *Eubalaena glacialis*, population. *Marine Mammal Science* 10: 253–265.
- Caldwell, M.C. & Caldwell, D.K. (1968). Vocalization of naive captive dolphins in small groups. *Science* 159(3819): 1121–1123.
- Cazau, D., Adam, O., Laitman, J.T. & Reidenberg, J.S. (2013). Understanding the intentional acoustic behavior of humpback whales: A production-based approach. *The Journal of the Acoustical Society of America* 134: 2268–2273.
- Charlton, B.D., Ellis, W. a H., McKinnon, A.J., Cowin, G.J., Brumm, J., Nilsson, K. & Fitch, W.T. (2011). Cues to body size in the formant spacing of male koala (*Phascolarctos cinereus*) bellows: honesty in an exaggerated trait. *The Journal of Experimental Biology* 214: 3414–3422.
- Charrier, I., Mathevon, N. & Jouventin, P. (2002). How does a fur seal mother recognize the voice of her pup? An experimental study of *Arctocephalus tropicalis*. *The Journal of Experimental Biology* 205: 603–612.
- Charrier, I., Pitcher, B.J. & Harcourt, R.G. (2009). Vocal recognition of mothers by Australian sea lion pups: individual signature and environmental constraints. *Animal Behaviour* 78(5): 1127–1134.
- Christie, P., Mennill, D. & Ratcliffe, L. (2004). Chickadee song structure is individually distinctive over long broadcast distances. *Behaviour* 141: 101–124.
- Clark, C.W. (1982). The acoustic repertoire of the Southern right whale, a quantitative analysis. *Animal Behaviour* 30: 1060–1071.
- Clark, C.W. & Clapham, P.J. (2004). Acoustic monitoring on a humpback whale (*Megaptera novaeangliae*) feeding ground shows continual singing into late Spring. *Proceedings of the Royal Society B: Biological Sciences* 271: 1051–1057.
- Clark, C.W. & Clark, J.M. (1980). Sound playback experiments with Southern right whales (*Eubalaena australis*). *Science* 207(4431): 663–665.
- Clark, C.W., Gillespie, D., Nowacek, D.P. & Parks, S.E. (2007). Listening to their world: acoustics for monitoring and protecting right whales in an urbanized ocean. In S. D. Kraus & R. M. Rolland (eds.), *The Urban Whale: North Atlantic Right Whales at the Crossroads*. Cambridge, MA: Harvard University Press.

- Clutton-Brock, T.H. & Albon, S.D. (1979). The roaring of red deer and the evolution of honest advertisement. *Behaviour* 69(3): 145–170.
- Dale, J., Lank, D.B. & Reeve, H.K. (2001). Signaling individual identity versus quality: a model and case studies with ruffs, queleas, and house finches. *The American Naturalist* 158(1): 75–86.
- Dávid-Barrett, T. & Dunbar, R.I.M. (2013). Processing power limits social group size: computational evidence for the cognitive costs of sociality. *Proceedings of the Royal Society B: Biological Sciences* 280: 20131151.
- Dormer, K.J. (1979). Mechanism of sound production and air recycling in delphinids: Cineradiographic evidence. *The Journal of the Acoustical Society of America* 65(1): 229.
- Dunbar, R.I.M. (1998). The social brain hypothesis. *Evolutionary Anthropology* 178–190.
- Espmark, Y. (1971). Individual recognition by voice in reindeer mother-young relationship: field observations and playback experiments. *Behaviour* 40(3): 295–301.
- Fant, G. (1960). *Acoustic Theory of Speech Production*. The Hague, The Netherlands: Mouton & Co.
- Fitch, W.T. (2000). The evolution of speech: a comparative review. *Trends in Cognitive Sciences* 4(7): 258–267.
- Fitch, W.T. & Hauser, M.D. (1995). Vocal production in nonhuman primates: Acoustics, physiology and functional constraints on ‘honest’ advertisement. *American Journal of Primatology* 37: 191–219.
- Fortune, S.M.E., Trites, A.W., Perryman, W.L., Moore, M.J., Pettis, H.M. & Lynn, M.S. (2012). Growth and rapid early development of North Atlantic right whales (*Eubalaena glacialis*). *Journal of Mammalogy* 93(5): 1342–1354.
- Freeberg, T.M., Dunbar, R.I.M. & Ord, T.J. (2012). Social complexity as a proximate and ultimate factor in communicative complexity. *Philosophical Transactions of the Royal Society B: Biological Sciences* 367: 1785–1801.
- Friedlaender, A.S., Hazen, E.L., Nowacek, D.P., Halpin, P.N., Ware, C., Weinrich, M.T., ... Wiley, D. (2009). Diel changes in humpback whale *Megaptera novaeangliae* feeding behavior in response to sand lance *Ammodytes* spp. behavior and distribution. *Marine Ecology Progress Series* 395: 91–100.
- Hamilton, P.K. (2002). *Associations among North Atlantic right whales*. Masters Thesis, University of Massachusetts Boston.

- Hamilton, P.K. & Cooper, L.A. (2010). Changes in North Atlantic right whale (*Eubalaena glacialis*) cow-calf association times and use of the calving ground: 1993-2005. *Marine Mammal Science* 26: 896–916.
- Hamilton, P.K., Knowlton, A.R. & Marx, M.M. (2007). Right whales tell their own stories: the photo-identification catalog. In S. D. Kraus & R. M. Rolland (eds.), *The Urban Whale: North Atlantic Right Whales at the Crossroads*. Cambridge, MA: Harvard University Press.
- Hoyt, E. (2011). *Marine Protected Areas for Whales, Dolphins and Porpoises: A World Handbook for Cetacean Habitat Conservation and Planning* (Second Ed.). New York, NY: Earthscan.
- IBM Corp. (2013). IBM SPSS Statistics for Windows. Armonk, NY: IBM Corp.
- Janik, V. & King, S. (2013). Identifying signature whistles from recordings of groups of unrestrained bottlenose dolphins (*Tursiops truncatus*). *Marine Mammal Science* 29: 109–122.
- Janik, V.M. & Sayigh, L.S. (2013). Communication in bottlenose dolphins: 50 years of signature whistle research. *Journal of Comparative Physiology A: Neuroethology, Sensory, Neural, and Behavioral Physiology* 199: 479–489.
- Johnson, M.P. & Tyack, P.L. (2003). A digital acoustic recording tag for measuring the response of wild marine mammals to sound. *IEEE Journal of Oceanic Engineering* 28(1): 3–12.
- Johnsson, J.I. (2010). Individual Recognition Affects Aggression and Dominance Relations in Rainbow Trout, *Oncorhynchus mykiss*. *Ethology* 103: 267–282.
- Johnston, R.E. & Bullock, T.A. (2001). Individual recognition by use of odours in golden hamsters: the nature of individual representations. *Animal Behaviour* 61: 545–557.
- Johnstone, R.A. (1997). Recognition and the evolution of distinctive signatures: when does it pay to reveal identity? *Proceedings of the Royal Society B: Biological Sciences* 264: 1547–1553.
- Katona, S.K. & Beard, J.A. (1990). Population size, migrations, and feeding aggregations of the humpback whale (*Megaptera novaeangliae*) in the western North Atlantic Ocean. *Reports of the International Whaling Commission* (Special Issue 12): 295–306.
- King, S., Harley, H.E. & Janik, V.M. (2014). The role of signature whistle matching in bottlenose dolphins (*Tursiops truncatus*). *Animal Behaviour* in press: 79–86.
- Kraus, S.D. & Hatch, J.J. (2001). Mating strategies in the North Atlantic right whale (*Eubalaena glacialis*). *Journal of Cetacean Research and Management* 2: 237–244.

- Kraus, S.D. & Hatch, J.J. (2001). Mating strategies in the North Atlantic right whale (*Eubalaena glacialis*). *Journal of Cetacean Research and Management* (Special Issue 2): 237–244.
- Kraus, S.D., Pace III, R.M. & Frasier, T.R. (2007). High investment, low return: the strange case of reproduction in *Eubalaena glacialis*. In S. D. Kraus & R. M. Rolland (eds.), *The Urban Whale: North Atlantic Right Whales at the Crossroads*. Cambridge, MA: Harvard University Press.
- Kraus, S.D. & Rolland, R.M. (2007). Right whales in the urban ocean. In S. D. Kraus & R. M. Rolland (eds.), *The Urban Whale: North Atlantic Right Whales at the Crossroads*. Cambridge, MA: Harvard University Press.
- Lagueux, K.M., Zani, M.A., Knowlton, A.R. & Kraus, S.D. (2011). Response by vessel operators to protection measures for right whales *Eubalaena glacialis* in the southeast US calving ground. *Endangered Species Research* 14: 69–77.
- Legendre, P. & Legendre, L. (2012). Multivariate regression trees (MRT). In *Numerical Ecology* (Third English Ed.). Elsevier.
- Lemasson, A., Palombit, R.A. & Jubin, R. (2008). Friendships between males and lactating females in a free-ranging group of olive baboons (*Papio hamadryas anubis*): Evidence from playback experiments. *Behavioral Ecology and Sociobiology* 62: 1027–1035.
- Matthews, L.P., McCordic, J.A. & Parks, S.E. (2014). Remote acoustic monitoring of North Atlantic right whales (*Eubalaena glacialis*) reveals seasonal and diel variations in acoustic behavior. *PloS one* 9(3): e91367.
- May-Collado, L.J., Agnarsson, I. & Wartzok, D. (2007). Phylogenetic review of tonal sound production in whales in relation to sociality. *BMC Evolutionary Biology* 7: 136.
- McCulloch, S., Pomeroy, P.P. & Slater, P.J. (1999). Individually distinctive pup vocalizations fail to prevent allo-suckling in grey seals. *Canadian Journal of Zoology* 77(May): 716–723.
- McDonald, M.A. & Moore, S.E. (2002). Calls recorded from North Pacific right whales (*Eubalaena japonica*) in the eastern Bearing Sea. *The Journal of Cetacean Research and Management* 4(3): 261–266.
- Mellinger, D., Stafford, K., Moore, S., Dziak, R. & Matsumoto, H. (2007). An Overview of Fixed Passive Acoustic Observation Methods for Cetaceans. *Oceanography* 20(4): 36–45.
- Mellinger, D.K., Nieuwkirk, S.L., Matsumoto, H., Heimlich, S.L., Dziak, R.P., Haxel, J., Fowler, M., Meinig, C. & Miller, H.V. (2007). Seasonal occurrence of North Atlantic right whale (*Eubalaena glacialis*) vocalizations at two sites on the Scotian Shelf. *Marine Mammal Science* 23: 856–867.

- Mercado III, E. & Frazer, L.N. (1999). Environmental constraints on sound transmission by humpback whales. *Journal of the Acoustical Society of America* 106(5): 3004–3016.
- Merrick, R.L. (2005). Seasonal management area to reduce ship strikes of northern right whales in the Gulf of Maine. *Northeast Fisheries Science Center Reference Document 05-19*. 18p. 2005. (December): 28.
- Mobley, J.R.J. & Herman, L.M. (1985). Transience of social affiliations among humpback whales on the Hawaiian wintering grounds. *Canadian Journal of Zoology* 63: 762–772.
- Munger, L.M., Wiggins, S.M. & Hildebrand, J. a. (2011). North Pacific right whale up-call source levels and propagation distance on the southeastern Bering Sea shelf. *The Journal of the Acoustical Society of America* 129: 4047–4054.
- Mussoline, S.E., Risch, D., Hatch, L.T., Weinrich, M.T., Wiley, D.N., Thompson, M.A., Corkeron, P.J. & Van Parijs, S.M. (2012). Seasonal and diel variation in North Atlantic right whale up-calls: Implications for management and conservation in the northwestern Atlantic ocean. *Endangered Species Research* 17(1): 17–26.
- Nousek, A.E., Slater, P.J.B., Wang, C. & Miller, P.J.O. (2006). The influence of social affiliation on individual vocal signatures of northern resident killer whales (*Orcinus orca*). *Biology Letters* 2: 481–484.
- Nowacek, D.P., Johnson, M.P. & Tyack, P.L. (2004). North Atlantic right whales (*Eubalaena glacialis*) ignore ships but respond to alerting stimuli. *Proceedings of the Royal Society B: Biological Sciences* 271: 227–231.
- Nowacek, D.P., Johnson, M.P., Tyack, P.L., Shorter, K.A., McLellan, W.A. & Pabst, D.A. (2001). Buoyant balaenids: the ups and downs of buoyancy in right whales. *Proceedings of the Royal Society B: Biological Sciences* 268: 1811–1816.
- Parinet, B., Lhote, A. & Legube, B. (2004). Principal component analysis: An appropriate tool for water quality evaluation and management - Application to a tropical lake system. *Ecological Modelling* 178: 295–311.
- Parks, S.E. (2003). Response of North Atlantic right whales (*Eubalaena glacialis*) to playback of calls recorded from surface active groups in both the North and South Atlantic. *Marine Mammal Science* 19: 563–580.
- Parks, S.E., Brown, M.W., Conger, L.A., Hamilton, P.K., Knowlton, A.R., Kraus, S.D., Slay, C.K. & Tyack, P.L. (2007). Occurrence, composition, and potential functions of North Atlantic right whale (*Eubalaena glacialis*) surface active groups. *Marine Mammal Science* 23: 868–887.

- Parks, S.E. & Clark, C.W. (2007). Acoustic communication: social sounds and the potential impacts of noise. In S. D. Kraus & R. M. Rolland (eds.), *The Urban Whale: North Atlantic Right Whales at the Crossroads*. Cambridge, MA: Harvard University Press.
- Parks, S.E., Hamilton, P.K., Kraus, S.D. & Tyack, P.L. (2005). The gunshot sound produced by male North Atlantic right whales (*Eubalaena glacialis*) and its potential function in reproductive advertisement. *Marine Mammal Science* 21: 458–475.
- Parks, S.E., Johnson, M., Nowacek, D. & Tyack, P.L. (2011). Individual right whales call louder in increased environmental noise. *Biology Letters* 7: 33–35.
- Parks, S.E., Searby, A., Célérier, A., Johnson, M.P., Nowacek, D.P. & Tyack, P.L. (2011). Sound production behavior of individual North Atlantic right whales: Implications for passive acoustic monitoring. *Endangered Species Research* 15: 63–76.
- Parks, S.E. & Tyack, P.L. (2005). Sound production by North Atlantic right whales (*Eubalaena glacialis*) in surface active groups. *The Journal of the Acoustical Society of America* 117: 3297–3306.
- Parks, S.E., Urazghildiiev, I. & Clark, C.W. (2009). Variability in ambient noise levels and call parameters of North Atlantic right whales in three habitat areas. *The Journal of the Acoustical Society of America* 125: 1230–1239.
- Parks, S.E., Warren, J.D., Stamieszkin, K., Mayo, C. a. & Wiley, D. (2012). Dangerous dining: surface foraging of North Atlantic right whales increases risk of vessel collisions. *Biology Letters* 8: 57–60.
- Payne, R. & Dorsey, E.M. (1983). Sexual dimorphism and aggressive use of callosities in right whales (*Eubalaena australis*). In R. Payne (ed.), *Communication and Behavior of Whales*. Boulder, CO: Westview Press.
- Payne, R. & McVay, S. (1971). Songs of humpback whales. *Science* 173(3997): 585–597.
- Pollard, K.A. & Blumstein, D.T. (2011). Social group size predicts the evolution of individuality. *Current Biology* 21(5): 413–417.
- R Core Team. (2012). R: A language and environment for statistical computing. Vienna, Austria: R Foundation for Statistical Computing. Retrieved from <http://www.r-project.org>
- Ramp, C., Hagen, W., Palsbøll, P., Bérubé, M. & Sears, R. (2010). Age-related multi-year associations in female humpback whales (*Megaptera novaeangliae*). *Behavioral Ecology and Sociobiology* 64: 1563–1576.
- Reby, D., André-Obrecht, R., Galinier, A., Farinas, J. & Cargnelutti, B. (2006). Cepstral coefficients and hidden Markov models reveal idiosyncratic voice characteristics in red deer (*Cervus elaphus*) stags. *The Journal of the Acoustical Society of America* 120: 4080–4089.

- Reby, D., Joachim, J., Lauga, J., Lek, S. & Aulagnier, S. (1998). Individuality in the groans of fallow deer (*Dama dama*) bucks. *Journal of Zoology* 245: 79–84.
- Reby, D. & McComb, K. (2003). Anatomical constraints generate honesty: acoustic cues to age and weight in the roars of red deer stags. *Animal Behaviour* 65:519–530.
- Reidenberg, J.S. & Laitman, J.T. (2007). Discovery of a low frequency sound source in mysticeti (baleen whales): Anatomical establishment of a vocal fold homolog. *Anatomical Record* 290: 745–759.
- Rendall, D., Rodman, P.S. & Emond, R.E. (1996). Vocal recognition of individuals and kin in free-ranging Rhesus monkeys. *Animal Behaviour* 51: 1007–1015.
- Richardson, W.J., Greene, C.R.J., Malme, C.I. & Thomson, D.H. (1995). *Marine Mammals and Noise*. Herndon, VA: Academic Press.
- Riesch, R., Ford, J.K.B. & Thomsen, F. (2006). Stability and group specificity of stereotyped whistles in resident killer whales, *Orcinus orca*, off British Columbia. *Animal Behaviour* 71: 79–91.
- Ryan, M.J. (1990). The sensory basis of sexual selection for complex calls in the tungara frog, *Physalaemus pustulosus* (sexual selection for sensory exploitation). *Evolution* 44(2): 305–314.
- Sayigh, L.S., Esch, H.C., Wells, R.S. & Janik, V.M. (2007). Facts about signature whistles of bottlenose dolphins, *Tursiops truncatus*. *Animal Behaviour* 74: 1631–1642.
- Schoenfuss, H.L., Bragulla, H.H., Schumacher, J., Henk, W.G., Craig George, J. & Hillmann, D.J. (2014). The anatomy of the larynx of the bowhead whale, *Balaena mysticetus*, and its sound-producing functions. *Anatomical Record* 297: 1316–1330.
- Sebe, F., Nowak, R., Poindron, P. & Aubin, T. (2007). Establishment of vocal communication and discrimination between ewes and their lamb in the first two days after parturition. *Developmental Psychobiology* 49: 375–386.
- Sousa-Lima, R. (2002). Signature information and individual recognition in the isolation calls of Amazonian manatees, *Trichechus inunguis* (Mammalia: Sirenia). *Animal Behaviour* 63: 301–310.
- Sousa-Lima, R.S., Paglia, A.P. & da Fonseca, G.A.B. (2008). Gender, age, and identity in the isolation calls of Antillean manatees (*Trichechus manatus manatus*). *Aquatic Mammals* 34(1): 109–122.
- Taylor, A.M. & Reby, D. (2010). The contribution of source-filter theory to mammal vocal communication research. *Journal of Zoology* 280: 221–236.

- Therneau, T., Atkinson, B. & Ripley, B. (2014). Package ‘rpart’.
- Tibbetts, E.A. (2002). Visual signals of individual identity in the wasp *Polistes fuscatus*. *Proceedings of the Royal Society B: Biological Sciences* 269: 1423–1428.
- Tibbetts, E.A. & Dale, J. (2007). Individual recognition: it is good to be different. *Trends in Ecology and Evolution* 22(10): 529–537.
- Titze, I.R. (2000). *Principles of Voice Production* (Second Printing). Iowa City, IA: National Center for Voice and Speech.
- Torriani, M.V.G., Vannoni, E. & McElligott, A.G. (2006). Mother-young recognition in an ungulate hider species: a unidirectional process. *The American Naturalist* 168(3): 412–420.
- Tyack, P.L. & Miller, E.H. (2002). Vocal anatomy, acoustic communication and echolocation. In A. R. Hoelzel (ed.), *Marine Mammal Biology: An Evolutionary Approach*. Malden, MA: Blackwell Publishing.
- Urazghildiiev, I.R. (2014). Statistical analysis of North Atlantic right whale (*Eubalaena glacialis*) signal trains in Cape Cod Bay, spring 2012. *The Journal of the Acoustical Society of America* 136: 2851–2860.
- Van Parijs, S.M., Clark, C.W., Sousa-Lima, R.S., Parks, S.E., Rankin, S., Risch, D. & Van Opzeeland, I.C. (2009). Management and research applications of real-time and archival passive acoustic sensors over varying temporal and spatial scales. *Marine Ecology Progress Series* 395: 21–36.
- Vannoni, E. & McElligott, A.G. (2007). Individual acoustic variation in fallow deer (*Dama dama*) common and harsh groans: A source-filter theory perspective. *Ethology* 113: 223–234.
- Waring, G.T., Josephson, E., Maze-Foley, K. & Rosel, P.E. (2014). NOAA Technical Memorandum NMFS-NE-228: U . S . Atlantic and Gulf of Mexico Marine Mammal Stock Assessments - 2013. *National Oceanic and Atmospheric Administration* (July): 606.
- Weinrich, T. (1991). Stable social associations among humpback whales (*Megaptera novaeangliae*) in the southern Gulf of Maine. *Canadian Journal of Zoology* 69: 3012–3018.
- Wiggins, S.M., McDonald, M.A., Munger, L.M., Moore, S.E. & Hildebrand, J.A. (2004). Waveguide propagation allows range estimates for North Pacific right whales in the Bering Sea. *Canadian Acoustics* 32(2): 146–154.

VITA

Full name of author

Jessica Annalisa Maverique McCordic

Date of birth

13 November, 1990

Graduate and undergraduate schools attended

Syracuse University, Syracuse, New York
College of the Atlantic, Bar Harbor, Maine

Degrees Awarded

Bachelor of Arts in Human Ecology, 2012, College of the Atlantic, Bar Harbor, Maine

Publications

Matthews, L. P., **J. A. McCordic**, S. E. Parks. 2014. Remote acoustic monitoring of North Atlantic right whales (*Eubalaena glacialis*) reveals seasonal and diel variations in acoustic behavior. PLOS ONE. doi:10.1371/journal.pone.0091367

McCordic, J.A., S. K. Todd, P. T. Stevick. 2013. Differential rates of killer whale (*Orcinus orca*) attacks on humpback whales (*Megaptera novaeangliae*) in the North Atlantic as determined by scarification. Journal of the Marine Biological Association of the United Kingdom. doi:10.1017/S0025315413001008.

Research experience

North Atlantic Right Whales: Mother-calf Behavioral Study, 2013 – 2015
Acoustic Behavior of Orthopteran Insects of Central New York, 2013 – 2015
Field Recordings of Humpback Whales, 2012
Humpback Whales and Whale Watching Interactions, 2011
Allied Whale Internship, 2010
Acoustic Behavior of North Atlantic Right Whales, 2009 – 2011

Teaching experience

Teaching Assistant, Biology I and II, Syracuse University, 2012 – 2015
Teaching Assistant, Ocean Life, Syracuse University, 2013
Teaching Assistant, Human Ecology of Newfoundland, College of the Atlantic, 2011
Writing Tutor, College of the Atlantic, 2011 – 2012
Teaching Assistant, Chemistry I and II, College of the Atlantic, 2010 – 2011