

Syracuse University

SURFACE

Electrical Engineering and Computer Science -
Technical Reports

College of Engineering and Computer Science

5-1990

Optical Switching and Routing Architectures for Fiber-optic Computer Communication Networks

Alok Choudhary
Syracuse University

Salim Hariri
Syracuse University

Wang Song

Partha Banerjee

Sanjay Ranka
Syracuse University

Follow this and additional works at: https://surface.syr.edu/eecs_techreports



Part of the [Computer Sciences Commons](#)

Recommended Citation

Choudhary, Alok; Hariri, Salim; Song, Wang; Banerjee, Partha; and Ranka, Sanjay, "Optical Switching and Routing Architectures for Fiber-optic Computer Communication Networks" (1990). *Electrical Engineering and Computer Science - Technical Reports*. 97.

https://surface.syr.edu/eecs_techreports/97

This Report is brought to you for free and open access by the College of Engineering and Computer Science at SURFACE. It has been accepted for inclusion in Electrical Engineering and Computer Science - Technical Reports by an authorized administrator of SURFACE. For more information, please contact surface@syr.edu.

SU-CIS-90-16

**Optical Switching and Routing Architectures
for Fiber-optic Computer Communication Networks**

Alok Choudhary, Salim Hariri, Wang Song, Partha Banerjee,
and
Sanjay Ranka

May 1990

School of Computer and Information Science
Syracuse University
Suite 4-116
Center for Science and Technology
Syracuse, New York 13244-4100

Optical Switching and Routing Architectures for Fiber-optic Computer Communication Networks

Alok Choudhary, Salim Hariri, Wang Song, Partha Banerjee

Department of Electrical and Computer Engineering

111 Link Hall, Ph: (315)-443-4280, FAX: (315)-443-4936

and

Sanjay Ranka

School of Computer and Information Science

Science and Technology Center

Syracuse University, Syracuse, NY 13244

May 11, 1990

Abstract

Optical technology has become a significant part of communication networks. We propose an Optical Interface Message Processor (OPTIMP) that exploits high-bandwidth, parallelism, multi-dimensional capability, and high storage density offered by optics. The most time consuming operations such as switching and routing in communication networks are performed in optical domain in the proposed system. Our design does not suffer from the optical/electrical conversion bottlenecks and can perform switching and routing in the range of Gigabits/s. The proposed design can have significant impact in high-speed communication networks as well as high-speed interconnection networks for parallel computers.

The source-destination (S-D) information from a message is first converted to the spatial domain. The routing table stores all S-D codes and the corresponding control codes for the switching module. Using a cylindrical system, the routing table is searched in parallel (single step) and control signals corresponding to the matched S-D row from the table are used to control the switching module. The switching module, based on the SEED array technology, can be reconfigured in GHz range and provide high bandwidth.

1 Introduction

It is predicted that future multimedia transport networks must effectively provide a wide range of services with different throughput requirements such as voice (64 Kbits/s), data (Megabits/s), high definition television (100 Megabits/s), and human vision (10-100 Giga-bits/s) [1]. Consequently, the designers of communication networks that will support this wide range and dynamic capacity requirements will be limited by the processing capabilities of the nodes that perform the required routing and switching functions in the electronics domain. Furthermore, the low-transmission bandwidth of the electronic switches, and the (O/E) and (E/O) conversions present an obstacle to fully exploit the large bandwidth offered by optics. Currently, intensive research is focused on removing this obstacle by proposing design alternatives that attempt to achieve transmission as well as switching in optical technology. We stress that the systems and network architectures designed based on electronics technology may not be feasible and/or efficient when electronic devices are substituted by equivalent optical devices.

Optical technology has a tremendous potential in high-speed and high-bandwidth communication networks due the following reasons:

- (a) inherent parallel and multidimensional capabilities;
- (b) high space-bandwidth and time-bandwidth products, resulting in fast transmission and switching capabilities;
- (c) immunization from mutual interference unless otherwise intended, thereby insuring freedom from topological limitations prevalent in semiconductor technology.

In communication networks, the information exchange process can be divided into two parts: application related layers and communication related layers. The function of the

latter is to route data packets, generated from the former, from one user to another. This is achieved by using transmission lines and intelligent switching elements, which are also called Interface Message Processors (IMPs). The IMPs examine the source-destination (SD) code in the *header* of a packet to determine the outgoing link to be used in routing the packet to its destination.

The signal processing and control based on optical technology is still in its infancy and lags behind what can be done using electrical technology. This has led to designing of networks, such as the overlay network, in which the IMPs strip off the packet header from the message and convert the header into electrical signals. These electrical signals control the state of the photonic switches that route the packet at the input port to the required output port [2]. Others use different multiplexing techniques such as time-division and wavelength-division multiplexing to design photonic switches to route optical signals from their input ports to their corresponding output ports [3, 4, 5]. For example, in wavelength-division multiplexing, each input signal is modulated with a wavelength that corresponds to the destination port. The optical receiver at each output port is then used to select the input signal that is modulated with its commensurate wavelength. By modifying the tunable wavelength of these receivers, the output port can receive the input signal from any other input. In [6], a photonic knockout switch based on wavelength division multiplexing is proposed. Self-routing photonic switching with optically processed control is proposed in [7]. In this network, packets headers are encoded with packet destination addresses using either optical code-division or time-division encoding techniques.

The design approaches discussed above use analog devices such as filters, optical summing circuit, and optical receivers to achieve the desired routing function. Hence, they are sequential in nature. In packet switching systems, the information present in the header is examined in order to provide appropriate network routing. One control strategy could be

based on sorting the input packet by their destination addresses. The STARLITE wide-band digital switch is based on sorting networks that could eventually be implemented using optical logic and interconnects [8, 9].

In this paper we present an Optical Interface Message Processor (OPTIMP) that exploits high-bandwidth, parallelism, multi-dimensional capability, and high storage density offered by optics. The most time consuming operations such as switching and routing in communication networks are performed in optical domain in the proposed system. Furthermore, the OPTIMP does not suffer from the optical/electrical conversion bottlenecks and can perform switching and routing in the range of Gigabits/s.

The rest of this paper is organized as follows. Section 2 presents our design approach and design considerations. Functional description of OPTIMP is presented in Section 3. Section 4 describes the architecture of OPTIMP. Furthermore, an alternative design using holographic technique for reconfigurable switching network is also presented. Finally, conclusions and future research is outlined in Section 5.

2 Design Approach

This research proposes designs of an Optical Interface Message Processor (OPTIMP) that performs the functions associated with the subnet layers in optics, hereby removing the O/E and E/O conversion bottlenecks. Consequently, an optical packet will be routed through several successive IMPs until it reaches its destination where the packet is converted back to electrical signals and processed by the upper layers before it is delivered to the corresponding host (end user). The current optical devices lag far behind in sophistication and the control capability offered by electronic devices. Consequently, the optical subnet design must take into consideration and adopt schemes that are simple and can be implemented efficiently using the available optical technology.

The proposed design of an OPTIMP takes into considerations the points discussed above and performs simple routing and switching functions. The main characteristics of our design are:

1. The routing function is deterministic and all source-destination (SD) pairs are stored in a look-up table. For each input-output pair, the table stores information about which outgoing link to choose in order to route the packet. Most of the time, the topology of a network is fixed. However, infrequent changes can be made in the routing table (due to congestion or link failure). The contents of this routing table can be stored on an optical mask (hologram, or any other type of recording device viz., spatial light modulators). This technique takes advantage of the capability of optics to perform parallel search (single step search) on a two-dimensional optical array (routing table) as well as the high density storage capability of optics.
2. The control signals required to setup the optical switching devices use microprogramming. This simplifies the generation of control signals and can be performed in real-time. The routing table stores the patterns of the control signals needed to route a packet coming at an input port to the appropriate output port. The control are just read out from the appropriate row of the routing table. This operation can be performed in a single step due to the optical parallel search capabilities.
3. The switching network to connect the appropriate input and output links uses optical devices. This avoids O/E and E/O bottlenecks. Therefore, high data transmission rates that are available on the optical fibers can be sustained through the switches.

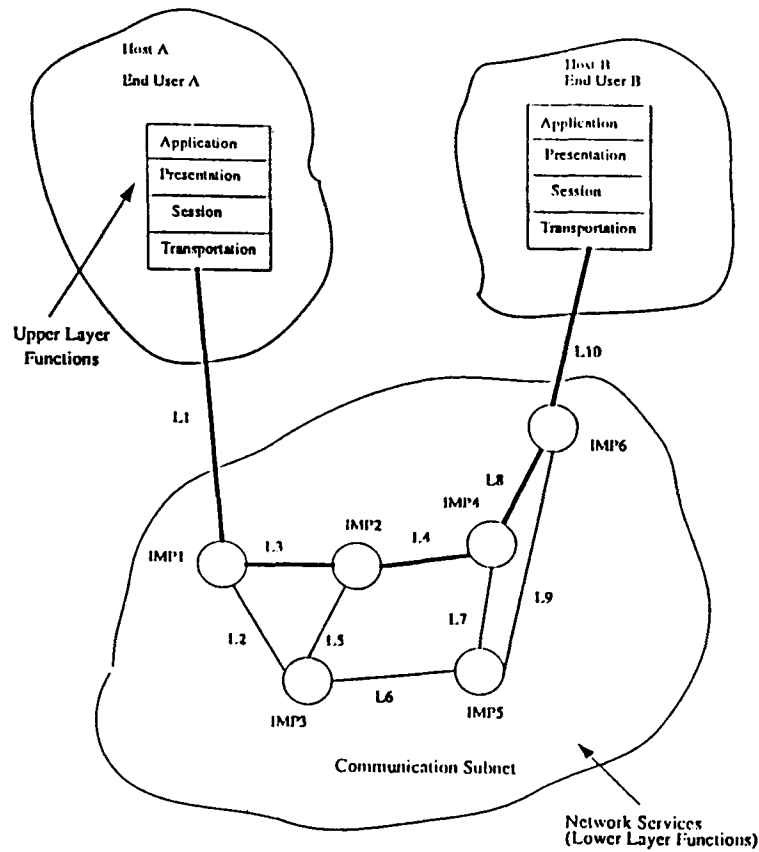

Figure 1: An Example of a Communication Network

3 Functional Description

Figure 1 shows an example of a communication network which shows the communications subnet portion as well as the names of the upper function layers. For example, in Figure 1 the dark lines show the path to be used to transport one packet from end-user A to end-user B. The routing table associate with IMP_1 routes every incoming packet with $SD=AB$ to link L_3 , while IMP_2 routes that packet to link L_4 , and so on until IMP_6 that delivers it to the end-user B through L_{10} . Infrequently, the routing table information needs to be modified to reflect the new status of the communication subnet. For example, if L_8 fails, the routing table of IMP_4 should be updated to route a packet with $SD = AB$ to L_7 instead of L_8 . Furthermore, the routing table of IMP_5 should also be modified to route that packet to L_9 where it is delivered to end-user B through L_{10} .

Conflict occurs when there are several packets that use the same output port to reach

their destinations and a protocol that addresses this type of conflicts can be developed for OPTIMP. For example, the control beams readout from the table for one packet are compared with those read for another packet and OPTIMP routes these two packets simultaneously only if the superimposition of these two sets of control beams do no lead to a conflict (such as using the same output port). In case there is a conflict, some arbitration mechanism is used to choose one of them or delay it using optical delay lines.

Figure 2 shows a block diagram of an OPTIMP. It performs parallel search on 2D optical routing table, which has high-density storage capacity that permits efficient storage of the routing information on a relatively small optical mask. There are m incoming fiber-in ports and n outgoing fiber-out ports. When a packet is received at one of these input ports as an optical signal, the optical power divider routes one copy of this packet to the Time-Space Converter (TSC) unit and another one to the Delay Line Unit. The TSC extracts the SD information from the packet header and displays it on a one-dimensional array of laser diodes. At this stage, a parallel search on all the columns of the routing table in the Optical Microprogrammed Routing Unit (OMRU) is performed to select the column corresponding to the given SD pair. The selected column provides the image pattern required to configure the Optical Switching Network (OSN) so that the incoming packet can be routed to the proper fiber-out port. The function of the delay line unit is to delay connecting the incoming packet to the OSN until the OMRU has produced the control beams required to configure the OSN.

4 Architecture

As we discussed in the previous section, the operation of the OPTIMP consists of several steps: time domain to spatial domain conversion, parallel table look-up, control pattern generation, and configuration of optically controlled interconnection network to achieve

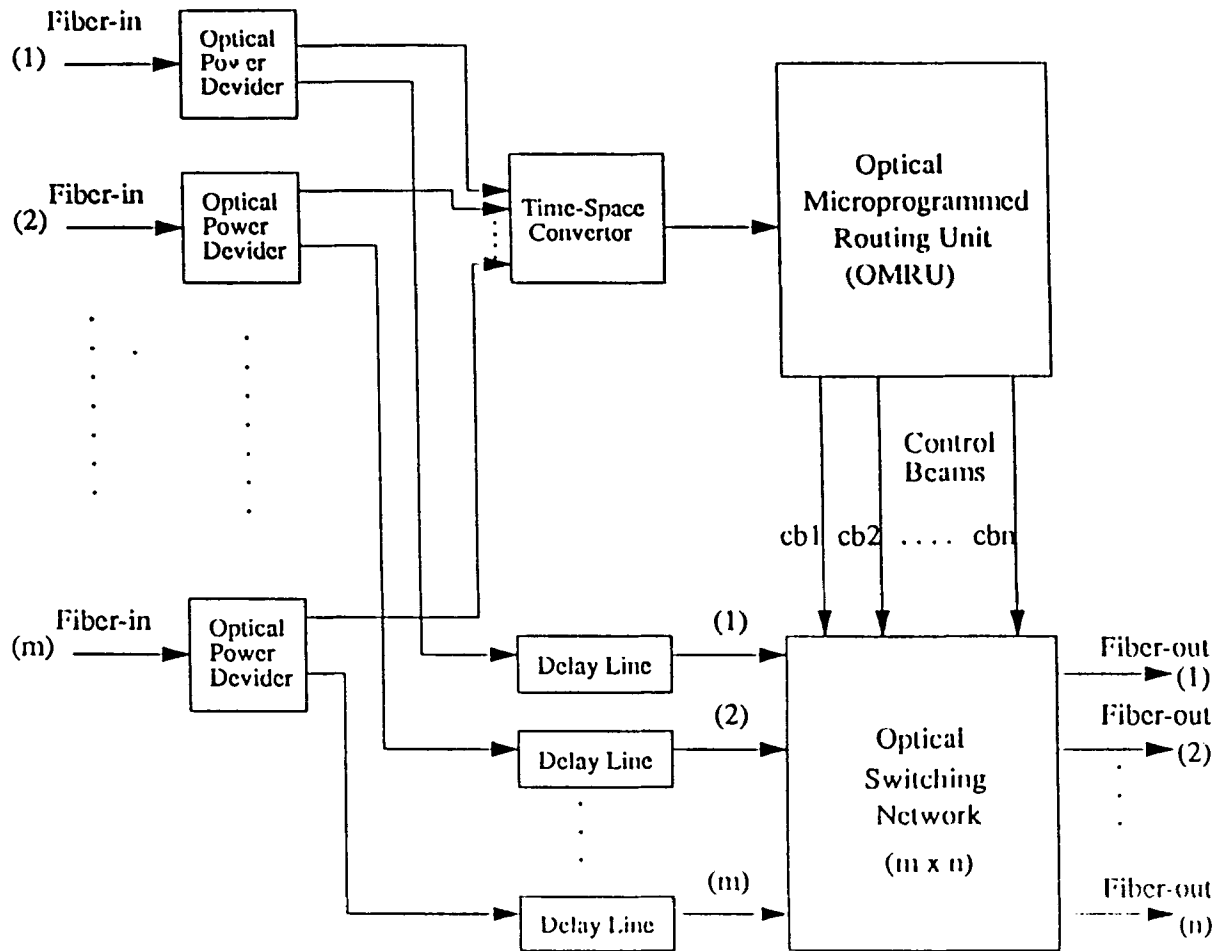

Figure 2: Functional Block Diagram of OPTIMP

real-time data routing. To achieve a non-blocking operation, a delay of the input data stream is also needed. In the following, we will discuss an implementation of the proposed OPTIMP.

The schematic diagram of the proposed OPTIMP is shown in Figure 3. For simplicity, most of the light guiding elements, such as mirrors, cylindrical lenses, and beam splitters are omitted. Also, only the main functional modules of OPTIMP are shown and details are omitted. In the diagram, SD and \overline{SD} are laser diode arrays that are driven by a high-speed shift register; TH is an optical intensity thresholding device; and RT , \overline{RT} and CT are programmable spatial light modulators (SLMs). We emphasize here that the modulators are used to display static routing and control patterns. The reading time will be the time for the light to pass them. Therefore, the slower writing response of the SLMs does not present any bottlenecks in the normal operations of the OPTIMP.

4.1 Time Domain to Space Domain Conversion

The input source and destination code from the incoming fiber is first converted into electrical pulses (for the SD code only). High-speed multiple quantum well photo-diode with switching time less than a nanosecond can be used for this purpose. The pulses are fed into a high speed electronic shift register that drives the two laser diode arrays. Notice that the shift register can store both the source destination code and its complement simultaneously. Therefore, the laser arrays simultaneously display the source and destination code and its complement in the spatial domain, respectively. Since both the shift register and laser arrays can operate at a rate above Gbits/s [10], this time domain to spatial domain conversion can also be in the range of Gbits/s, which is the data rate of fiber communications. The purpose of time to spatial domain conversion is that we can then use the parallel processing advantage of optics to achieve real-time and high-speed routing table search.

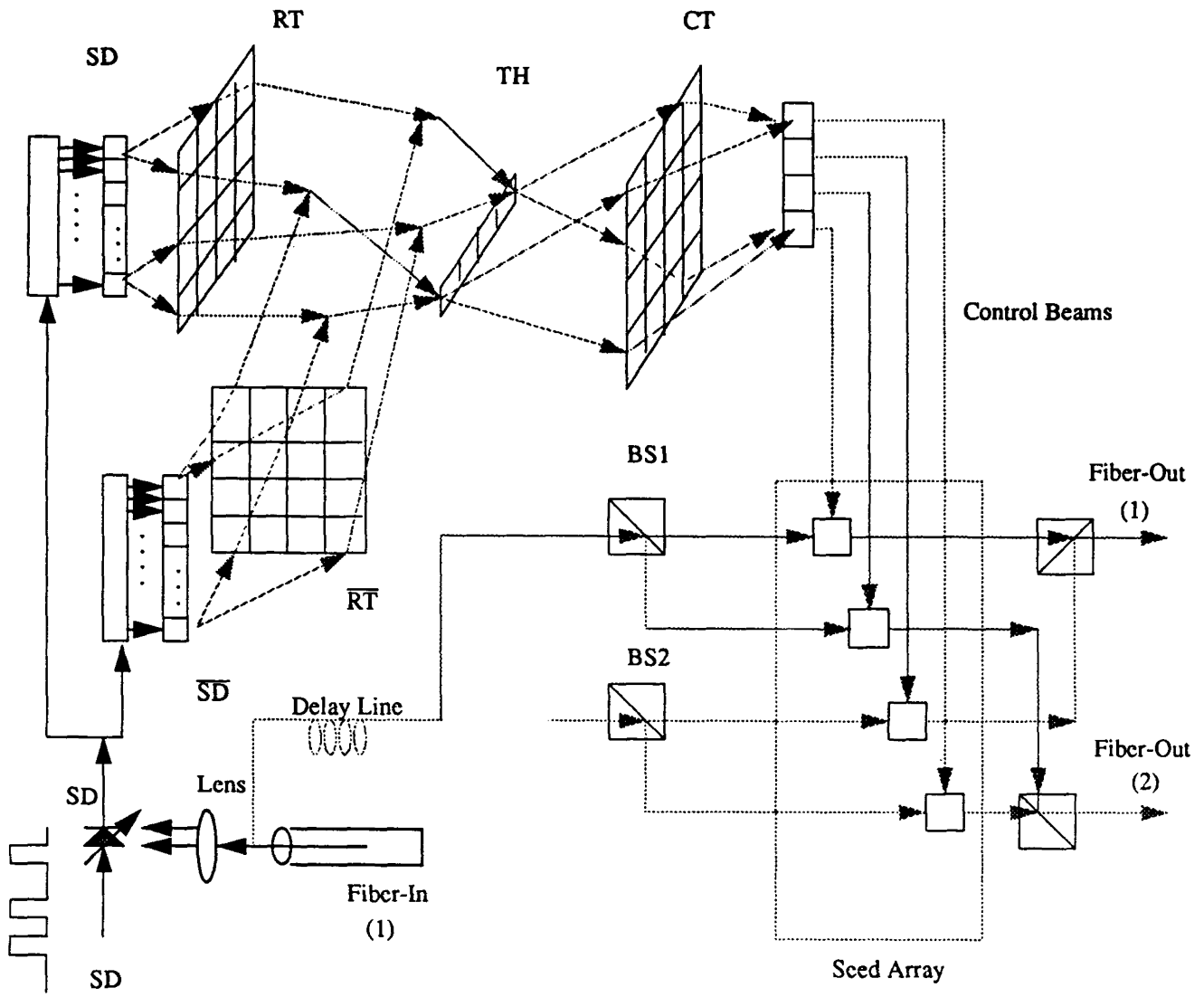

Figure 3: Main Modules of OPTIMP

4.2 Parallel Routing Table Search

The source destination code and its complement are displayed on SD and \overline{SD} , respectively. Here, we use positive logic (i.e., a binary *one* is represented by lasing and a binary *zero* is represented by no lasing). The routing table and its complement are displayed by two programmable spatial light modulators (RT and \overline{RT}), respectively. The magneto-optical spatial light modulator (MOD) [11] produced by Semitek can be used for this purpose. The device uses the Faraday effect to control the polarization of the light passing through it. An analyzer then converts the polarization into binary intensity transmittance. Therefore, according to the predetermined routing table, a pixel on the MOD is transparent (if it is a binary one) or opaque (if it is a binary zero). Each SD code of the routing table is designated by a column of pixels on the MOD. In other words, an $m \times n$ pixel MOD can represent n sets of source-destination codes with the length of each one being m . Although the achievable framerate (to update the routing table) of MOD is in the order of microseconds, we stress that during normal routing operations, the patterns displayed on the MODs (routing table entries) do not need to be changed. To read these patterns by light beams takes less than a nanosecond (10^{-9} sec., light travels a few centimeters). Therefore, the relative slow writing speed of the MOD does not limit the performance of the system in normal operation.

The cylindrical optical system (not shown in the figure) spreads each of the input bit on the laser arrays into a horizontal row that illuminates a row in one of the MOD masks. In this manner, the input SD and its complement codes represented by column laser arrays are simultaneously multiplied by each column in the routing table RT and its complement \overline{RT} , respectively. A beam splitter (not shown in the figure) combines the results of each bit multiplication. The following cylindrical lens (not shown in the figure) focuses each column of the multiplication results onto a pixel in the one-dimensional thresholding device TH.

From the Boolean logic point of view, the light intensity behind each column in the routing table RT is the AND operation between input SD code and a routing code, and the intensity behind each column in \overline{RT} is the AND operation between the corresponding complement codes. After beam combination and then focusing in the column direction, the intensity on the corresponding pixel of the thresholding device is expressed by Boolean function:

$$SD \cdot RT + \overline{SD} \cdot \overline{RT} = \textit{Equivalence}.$$

The Equivalence function determines the best match between the input SD code and one of the columns on the routing table. To be specific, if the input SD code matches one of the columns in the routing table, the total light energy passing the column will be maximum. Similarly, the total light energy passing the corresponding column on the \overline{RT} will also be a maximum. Upon adding them together by the beam splitter and cylindrical lens combination, the total energy on the pixel of the one-dimensional thresholding device TH that corresponding to these two columns is the maximum value.

4.3 Control Pattern Generation

The intensity thresholding value of the TH is properly set such that a pixel transmits light through it only if the total intensity impinging on it is above a predetermined value. Hence, there will be only one pixel on the device to be transparent. This pixel indicates the result of the parallel table search. Since the process is based on energy operation (i.e., incoherent optical operation), it has no requirement for the wavefront quality and a phase relationship for the laser source arrays. This results in a design with greater flexibility and lower cost.

The thresholding behavior of the TH device is shown in Figure 4. As can be observed, if the thresholding value is carefully chosen, a no-match (incorrect incoming SD code) can also be detected and ignored. Currently, the research for high-speed optical thresholding

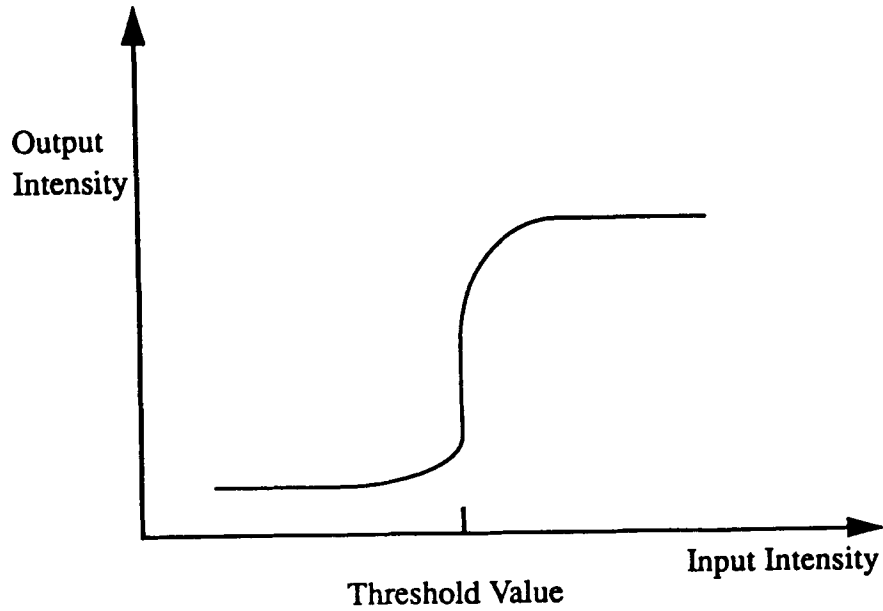

Figure 4: Non-Linear Behavior of a Thresholding Device

nonlinear etalon devices is underway at Syracuse University [?]. To insure accurate table search, the *SD* codes and the routing codes have to be properly designed. In other words, each column in the routing table must be able to transmit equal amount of light intensity, and the added results on the one-dimensional thresholding device *TH* must be sufficiently different so that the *TH* can make a correct decision. The design and implementation of the *SD* codes and the routing tables will be an integral part of the proposed research.

The cylindrical optical system behind TH (not shown in the figure), expands the light transmitted through the pixel in column direction to illuminate a corresponding column in the control table CT. This selected column is imaged onto the output plane to provide a binary control pattern for the optically controlled interconnection network.

4.4 Delay Generation

To achieve non-blocking real-time routing, the input data need to be delayed until the control signals are generated and the optical switches are set appropriately. The delay lines

in OPTIMP can be realized by means of optical fibers. However, if we desire delays of the order of picoseconds, an ordinary fiber can become prohibitively long for the purpose. We propose to construct periodic serrations into a single-mode fiber in order to achieve programmable delays. The serrations can be inserted by simply cutting grooves around the fiber at a small distance into the glass. A similar technique has been used previously in acoustics to introduce dispersion in the path of ultrasound traveling through an acousto-optics cell [12]. In principle, the section of glass between the serrations act as “locally reacting” strips which “impede” the propagation of, say, a Gaussian beam through the fiber. It can be shown that a typical dispersion curve obtainable is of the form $k^2 = \gamma_1 \omega \tan(\gamma_2 w)$ where ω and k denote the angular frequency and propagation constant, and γ_1 and γ_2 are constants dependent on the design parameters (e.g., the thickness and depth of the serrations). If the device is operated at a frequency commensurate with the spacing between the periodic serrations, one obtains a tunable filter with a large queue. On the other hand, in the “detuned” mode of operation, the device can accomplish a wide variation of group velocities depending on the frequency of the operation. A delay of 100 ns/m can be achieved for an operating wavelength of approximately of 1 micrometer. In fact, the group velocity can be changed to any desirable value over a large range simply by changing the periodicity, and the depth and width of the serrations.

4.5 Switching Network

The last functional module in the OPTIMP is the optically controlled switching network. In our schematic diagram in Figure 3, we show an light controlled SEED array network. The high speed (less than 1 ps) and low energy (of the order of fJ) self electro-optical device (SEED) [13] has drawn a great attention because of its inherent advantages suited for optical computing. A SEED device can function as an optically controlled light switch

that changes its transmittance according to the control (binary) light intensity. Therefore, the control pattern from the parallel table search can be used to control a two-dimensional SEED array. In other words, each SEED element in the array is individually switched “on” (transparent) or “off” (opaque). By doing so, any input port can be connected to any of the output port. Since SEED fabrication is based on molecular beam epitaxy (MBE), the number of SEED elements on a chip can be, in theory, very large. The control patterns can be imaged onto the SEED array by a refined optical imaging system. Thus we can achieve a very high density high speed crossbar or multistage network.

The SEED device, being still in research and development stage, is promising but expensive at present time. In the following, we describe an alternative using commercially available devices and materials for the switching network module of the OPTIMP.

Holographic Reconfigurable Interconnection Network (HRIN)

Another possible architecture for reconfigurable interconnections with volume holograms is spatial division. A page-oriented holographic setup is shown in Figure 5. We shall apply the pinhole hologram technique as proposed by Xu et. [14] into a nonlinear photorefractive crystal. The angular sensitivity of the recorded volume hologram would have a larger storage capacity as compared with thin holographic plates. The recording arrangement is shown in Figure 5(a), in which an SLM is in the focal plane of the condenser lens L_1 and the interconnection pattern masks are placed at the page plane p . The object beam B is focused by L_1 , after passing the SLM the beam is directed toward the recording medium. We notice that the SLM is used to generate a changeable pinhole, that allows only an object beam to pass in one direction. In other words, the interconnection mask is illuminated by an object beam in one direction, where the pinhole of SLM is set at a spatial location to allow the object beam to pass through. It may be seen that a set of interconnection masks

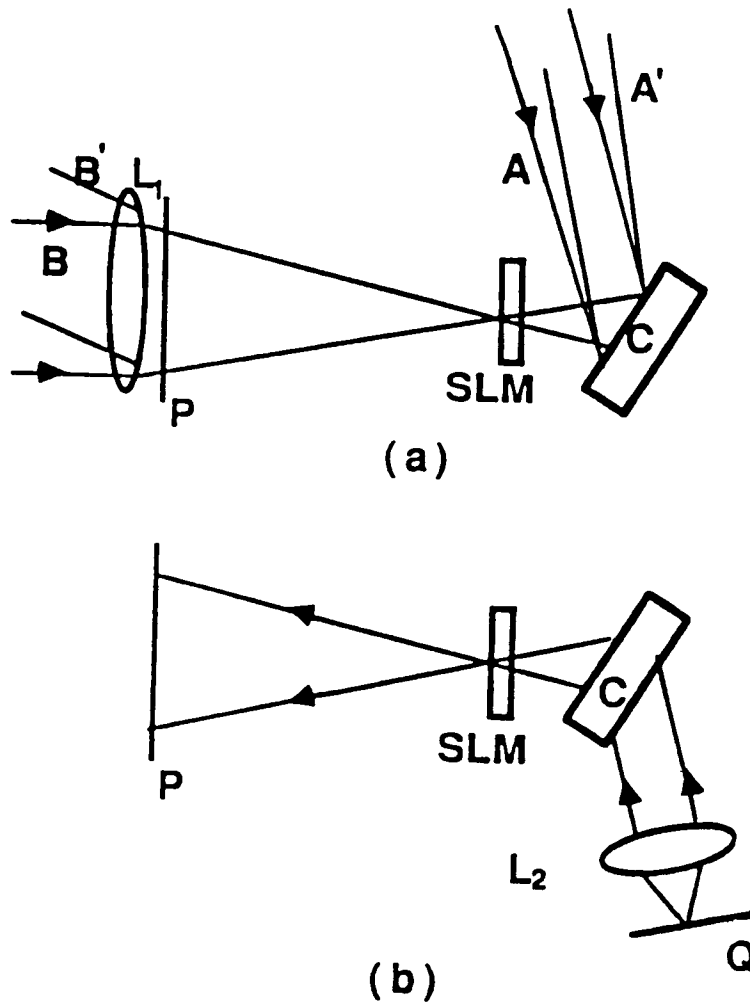

Figure 5: Geometry for Reconfigurable Interconnections with Spatial Division (a) recording setup (b) Reading Setup

can be encoded in the crystal for a given reference beam A' , and so on. In the read-out process, a 1-D laser diode array is placed at the front focal plane Q of the collimating lens L_2 as shown in Figure 5(b). Each diode generates a reading beam that is conjugate to a specific reference beam A . When the SLM pinhole is set at one position, a set of interconnection patterns will be diffracted at the page plane P . As the pinhole position is moved, the interconnections between the laser diode array and the page plane can be made reconfigurable by a programming SLM.

Unlike the wavelength tuning reconfigurable interconnection, the spatial division reconfiguration requires low wavelength sensitivity. We will use transmission type holograms

for interconnections. To have a higher angular sensitivity, the average write-in angle (2α) should be about 90° . If the thickness of the photorefractive crystal (i.e. $LiNbO_3$) is about 1 to 2 cm then the bandwidth of the hologram would be much wider than the signal bandwidth. Due to the degeneration of Bragg diffraction, only a one-dimensional laser diode array can be used. If the full range of $N \times N$ SLM pinholes is used, the total number of interconnection patterns would be $M = N^2 \times K$, where K is the number of channels (i.e., the number of laser diodes).

In principle, the architecture can be used for massive information storage. As an example if $N = 32$, $K = 10^3$, the total number of patterns (or pictures) would be 10^6 which is about the capacity of 10 hours of a TV program. This architecture does not require a high space-bandwidth product of the SLM (only 32×32). The requirement of the pinhole size is about $m\lambda F/a$, where $m \times m$ is the number of pixels, a is the size of the pictures, F is the focal length of the condenser lens L_1 . The size of the SLM is about $mN\lambda F/a$. The advantage of holographic interconnection is high interconnection density. For a detailed description the reader is referred to [15].

5 Conclusions

In this paper, we have presented a design for an Optical Interface Message Processor (OPTIMP) that exploits high-bandwidth, parallelism, multi-dimensional capability, and high storage density offered by optics. The most time consuming operations, such as source-destination table search and switching network setup are implemented fully in optics. In addition, since the switching network is all-optical, the system offers a high bandwidth. Our design does not suffer from the optical/electrical conversion bottlenecks and can perform switching and routing in the range of Gigabits/s. This design can be adapted for interconnection networks for massively parallel computers.

References

- [1] Eric Nussbaum, "Communication Network Needs and Technologies- A Place for Photonic Switching?" *IEEE Journal on Selected Areas in Communications* Vol. 6, No. 7, August 1988, pp. 1036-1043.
- [2] H. Scott Hinton, "Architectural Considerations for Photonic Switching Networks," *IEEE Journal on Selected Areas in Communications* Vol. 6, No. 7, August 1988, pp. 1209-1226.
- [3] A. S. Acampora, and M. J. Karol, "An Overview of Lightwave Packet Networks," *IEEE Network* January 1989, pp. 29-41.
- [4] A. Djupsjobacka, "Time Division Multiplexing Using Optical Switches," *IEEE Journal on Selected Areas in Communications* Vol. 6, No. 7, August 1988, pp. 1227-1231.
- [5] R. Ian Macdonald, "Terminology for Photonic Matrix Switches," *IEEE Journal on Selected Areas in Communications*, Vol. 6, No. 7, August 1988, pp. 1141-1151.
- [6] Kay Y. Eng, "A Photonic Knockout Switch for High-Speed Packet Networks," *IEEE Journal on Selected Areas in Communications* Vol. 6, No. 7, August 1988, pp. 1107-1116.
- [7] Paul R. Prucnal, and Philippe A. Perrier, "Self-Routing Photonic Switching with Optically Processed Control," *Optical Engineering* Vol. 29, No. 3, March 1990, pp. 170-182.
- [8] A. Huang, "Starlite: A Wideband Digital Switch," *Proc. IEEE Global Telecommunication Conference*, Atlanta, GA, Vol 1, pp. 121-125, Nov. 1984.
- [9] A. Huang, "The Relationship between STARLITE, a Wideband Digital Switch and Optics," *Proc. of International Conference on Communication*, Toronto, Ontario, Canada, June 22, 1986.
- [10] J. L. Jewell et al., "Surface-emitting microlasers for photonic switching and interchip connections," *Optical Engineering*, Vol. 29, pp. 210-214, March 1990.
- [11] W. E. Ross, D. Psaltis, and R. H. Anderson, "Two-dimensional magneto-optical spatial light modulator for signal processing," *Optical Engineering*, Vol 22, pp. 485- , 1983.
- [12] P. P. Banerjee and Q. Korpel, "Design of a Topologically Dispersive Acoustic Solution Tank," *Journal of Acoustic Society of America*, 80(4), pp. 1205-1208.
- [13] D. Miller, "Optoelectronic Applications of Quantum Wells," *Optics and Electronics News*, February 1990.
- [14] S. Xu, G. Mendes, S. Hart, J.C. Dainty "Pinhole Hologram and its Applications," *Optical Letters*, Vol. 14, 2, pp. 107, 1989.
- [15] S. Wu, Q. W. Song, A. Mayers, D. Gregory and F. Yu, "Reconfigurable Interconnections using Photorefractive Holograms," *Applied Optics*, Vol. 29, pp. 1118-1125, 1990.