

Syracuse University

SURFACE

Electrical Engineering and Computer Science

College of Engineering and Computer Science

2005

Global Multimedia Collaboration System

Geoffrey C. Fox

Indiana University, Community Grids, Pervasive Technology Labs

Wenjun Wu

Indiana University, Community Grids, Pervasive Technology Labs

Ahmet Uyar

Syracuse University, Department of Electrical Engineering and Computer Science, auyar@syr.edu

Hasan Bulut

Indiana University

Shrideep Pallickard

Indiana University, Community Grids, Pervasive Technology Labs

Follow this and additional works at: <https://surface.syr.edu/eecs>



Part of the [Computer Sciences Commons](#)

Recommended Citation

Fox, Geoffrey C.; Wu, Wenjun; Uyar, Ahmet; Bulut, Hasan; and Pallickard, Shrideep, "Global Multimedia Collaboration System" (2005). *Electrical Engineering and Computer Science*. 61.

<https://surface.syr.edu/eecs/61>

This Article is brought to you for free and open access by the College of Engineering and Computer Science at SURFACE. It has been accepted for inclusion in Electrical Engineering and Computer Science by an authorized administrator of SURFACE. For more information, please contact surface@syr.edu.

Global Multimedia Collaboration System

Geoffrey Fox¹, Wenjun Wu¹, Ahmet Uyar², Hasan Bulut¹, Shrideep Pallickara¹

gcf@indiana.edu, wewu@indiana.edu, auyar@mailbox.syr.edu,

hbulut@indiana.edu, spallick@indiana.edu

¹Community Grids, Pervasive Technology labs, Indiana University

²Department of Electrical Engineering & Computer Science, Syracuse University

Abstract

In order to build an integrated collaboration system over heterogeneous collaboration technologies, we propose a Global Multimedia Collaboration System (Global-MMCS) based on XGSP A/V Web-Services framework. This system can integrate multiple A/V services, and support various collaboration clients and communities. Now the prototype is being developed and deployed across many universities in USA and China.

Keywords: Collaboration, Web-Services, XGSP, Admire, NaradaBrokering

1. Introduction

Collaboration systems enable people in remote places to communicate and cooperate. And most collaboration systems are not designed in the approach of an open system and cannot communicate with each other. It will bring substantial benefits to Internet users if we can build an integrated collaboration environment, which combines conferencing, streaming, instant messaging as well as other collaboration applications into a single easy-to-use, intuitive environment. However, traditional collaboration systems can only provide limited collaboration capabilities to a small group of people in a local or private community. They have features that sometimes can be compared but often the systems make implicit architecture and implementation assumptions that hamper interoperability and functionality. Therefore it is very important to create a more general framework to cover the wide range of collaboration solutions and allow different users from different communities to collaborate.

The ITU standard package, H.323 [7] defines a complete framework for videoconferencing over ISDN and IP networks. But its data and A/V collaboration take different conference control mechanism, and is not very scalable. SIP [9] as a competing protocol against H.323 in VoIP is just beginning to put forward its own conferencing framework which is not as

mature as H.323. Since XML and Web Services provide a very powerful capability for meta-dating and constructing heterogeneous distributed systems, it is a very promising solution to build a general collaboration framework based on XML and Web Services technology.

In this paper, we propose to develop Global Multimedia Collaboration System (Global-MMCS) based on the XGSP web-services framework [3]. Global MMCS will integrate various services including videoconferencing, instant messaging and streaming, support multiple videoconferencing technologies and heterogeneous collaboration environments. The paper is organized as follows: In Section 2, the architecture of Global-MMCS is introduced. Section 3 presents the design and implementation of the prototype system. And we give the conclusion in section 4.

2. Global-MMCS Architecture

To build an integrated large-scale multimedia collaboration system over heterogeneous network environments, we have to design a scalable computing architecture and a flexible software framework. Figure 1 shows such a solution to our Global-MMCS. The Messaging event services provide publish-subscribe paradigm for all kinds of group communications in collaboration

applications. And it is implemented in a distributed messaging broker middleware, which helps to ensure QoS requirements of various collaboration applications over diverse network environments. The Collaboration Web services framework defines a general architecture, which

can integrate all possible collaboration services, for example videoconferencing, streaming, IM as well as shared application. On top of these services, all the services can be described, implemented and deployed.

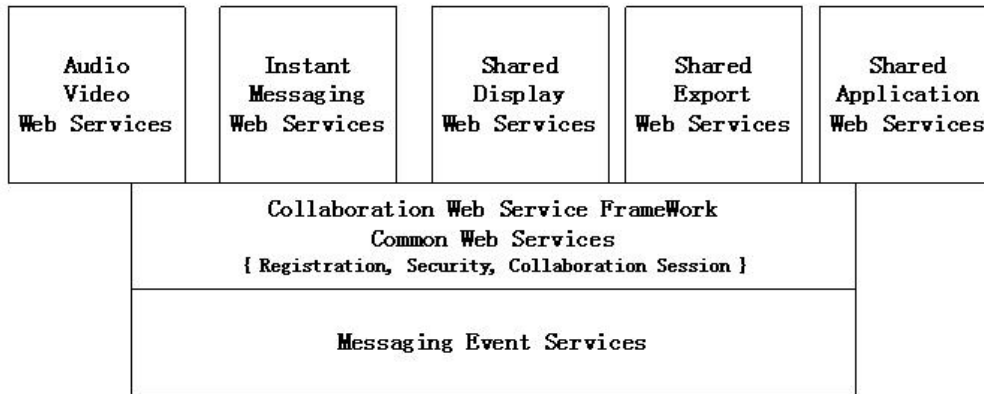

Figure 1 Global-MMCS Architecture

2.1 Global-MMCS Services

Videoconferencing services may include different collaboration systems, such as H.323, SIP [9] and AccessGrid [1] system. Real-Server will be added as a streaming Web-Service. Global-MMCS has SIP proxies and Jabber servers to provide Instant Messaging service. We allow users to use multiple types of clients to access Global-MMCS system, including H.323 terminals, SIP endpoints, MBONE tools, Real and Windows Media Players.

Collaboration pattern usually can be divided into two categories: ad-hoc mode, scheduled mode. Ad-hoc needs Instant Messenger to provide chat and remote presence services. And it can implement very dynamic membership, which is quite suitable for small group and informal collaborations. Scheduled mode needs meeting calendar to prepare the formal collaboration. People have to log into some web site or use emails to make reservation of some virtual meeting room, send invitations to other attendee in advance. Scheduled mode is better for formal and large scale collaborations. Global-MMCS will support the hybrid collaboration pattern, which allows users to

schedule formal meetings or to create small group ad-hoc meetings.

2.2 Web Services Architecture

The Session Web Service tries to provide a general session collaboration framework, which can support various kinds of collaboration tools. This framework includes two parts: one is XGSP (XML based General Session Protocol), which defines a general session protocol in XML. The other is WSDL-CI (WSDL Collaboration Interface), which gives an interface definition of any collaboration server. XGSP solves the issue of interconnecting the different collaboration tools for the same session. For example, we have AccessGrid, H.323 as well as SIP for videoconferencing. In order to make the servers and clients from different communities be able to communicate with each other, it is necessary to define only one session protocol which can be translated into AccessGrid, H.323, SIP messages and vice versa. WSDL-CI is used to describe the functionalities of the particular collaboration server. When we try to integrate the server into Global-MMCS, WSDL-CI provides the WSDL information to generate the interface component through which Global MMCS session server can

control this collaboration server and add it into current active session. For example, the global session server can schedule a third-party H.323 MCU into the collaboration, if this MCU declares its interface in WSDL-CI, including the methods of session establishment, session membership and session collaboration control.

There are different directories in Global-MMCS. The first is the directory of user account and media terminal. Unique user identifications help to authenticate valid users and bind the user to his media terminal. A user account may also include the information of user's media capability, for example, the audio terminal that the user wants to use. Also it is important to keep the directory of the active terminal, which the participant will use to access the media services. The second is the directory of different communities and collaboration servers. A community should be regarded as autonomous area that has its own collaboration control servers and media servers. The community directories will be used to integrate different services from different communities.

2.3 General Messaging Middleware (NaradaBrokering)

Collaboration applications for example videoconferencing usually need group communication. But current Internet cannot support group communication very well even with IP multicast solution which seems to have a long time to become ubiquitously available. Therefore messaging middleware is definitely necessary for group communication over heterogeneous networks. Since topic-based publish-subscribe model defines a general API for group communication, it seems to be a very good interface between collaboration applications and messaging middleware.

NaradaBrokering [4] from the Community Grid Labs is adapted as a general event brokering middleware. NaradaBrokering supports publish-subscribe messaging models with a dynamic collection of brokers. And it is

able to provide services for TCP, UDP, Multicast, SSL and raw RTP clients. For accessing the remote resources behind of a firewall, NaradaBrokering provides the capability of the communication through firewalls and proxies. It can operate either in a client-server mode like JMS or in a completely distributed JXTA-like peer-to-peer mode. By combining these two disparate models, NaradaBrokering can allow optimized performance-functionality trade-offs for different scenarios.

3. Global MMCS Prototype & Implementation

We plan to build a Global-MMCS prototype system across the sites in US and China. In China, we have a partner group called Admire [2], also working on videoconferencing systems. Admire group comes from National Software Development Environment Lab of Beihang University. Now they are beginning to deploy the Admire videoconferencing system across the universities in China. Admire developers will build web-services of Admire system based on our framework. Indiana A/V research group will use these web-services interface to integrate Admire with H.323, SIP as well as Real Networks streaming systems.

3.1 Admire Project in China

Admire project has been started in 1999 and finished a prototype system – Admire. The initial aim of the early project was to develop a large scale real-time multimedia interaction environment on top of NSCFnet, which allows users distributed in different sites of NSCFnet to make distant seminars and scientific collaboration through multiple collaboration tools. Now, the prototype system can support various collaboration tools and provide a complete conference management as well as conference archiving service. Furthermore, it can be deployed on heterogeneous network environments, supporting both unicast and multicast communication. By the end of 2002, Admire system has been deployed in over 20

sites in NSFCNET, CERNET China, and several sites in Japan and United States. Admire system is also interoperable with Access Grid, the de facto Internet2 multimedia collaborative environment.

3.2 Global MMCS Prototype System

Figure 2 shows the architecture of Global-MMCS prototype system that we are developing. The XGSP Web Server, XGSP naming & directory server and XGSP session server implement the web-services framework of Global-MMCS. Through SOAP connection, the

XGSP Web Server can invoke web-services provided by other communities, such as Admire and SIP. The XGSP Session Server translates the high-level command from the XGSP Web Server into signaling messages of XGSP, and sends these signaling messages to the NaradaBrokering servers to create a publish/subscribe session on the NaradaBrokering server. The distributed sets of NaradaBrokering nodes take the tasks of routing and forwarding video/audio events to various communities and collaboration clients.

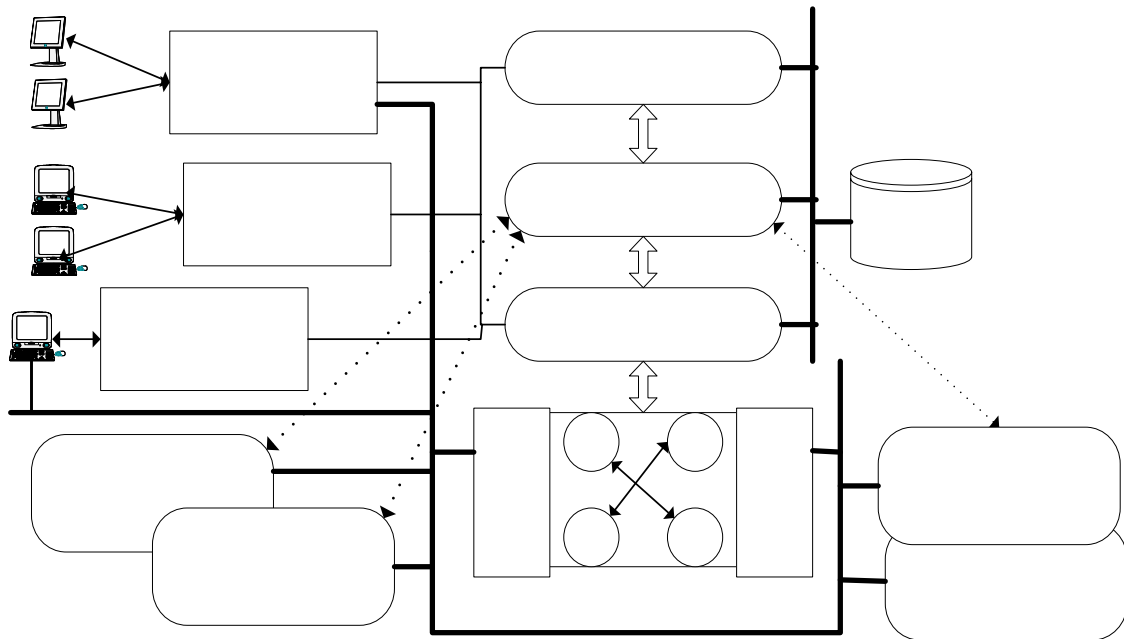

Figure 2 Global MMCS Prototype System

For different A/V clients, Global-MMCS has correspondent servers to accept their signaling requests and provide various services. The H.323 Servers including a H.323 Gatekeeper and H.323 gateway create a new H.323 administration domain for individual H.323 endpoints, translate H.225 and H.245 signaling from these endpoints into XGSP signaling messages, and redirect their RTP channels to the NaradaBrokering servers. The SIP Servers including a SIP Proxy, SIP Registrar and SIP Gateway create a similar SIP domain for SIP terminals and perform SIP translation. In addition, the SIP Proxy and SIP Gateway

provide the services of Instant Messaging and Chat room for A/V clients such as Windows Messenger. The Real Servers including a Real Producer and a Helix Server provide a streaming service to real-player and windows media player. Enhanced with customer input plug in, our Real Producer can receive RTP audio and video packets from network, encode them into Real format and submit them to the Helix Server. Real-players, as well as windows media players can use RealPlayer to connect the Helix Server and choose the multimedia streams that they are interested in.

The NaradaBrokering servers provide a H.323 Servers (Gatekeeper, Gateway)

Real Servers

(Real Producer, Helix Server)

SIP Servers

(Proxy, Registrar, Gateway)

H.323 Servers

(Gatekeeper, Gateway)

scalable distributed messaging platform for RTP communications in these A/V collaboration applications. Whenever a new session is activated across Global-MMCS, the same “topic” will be created inside NaradaBrokering system by XGSP session server. Any RTP client or server who wants to join in this session, it can “subscribe” to this topic and “publish” its RTP messages through RTP Proxies in the NaradaBrokering system. After we made some optimizations on the message transmission of NaradaBrokering system, it shows excellent performance for A/V communication. We have tested the performance of NaradaBrokering in

the case of high bandwidth video transmission: A video client sends a video stream to the NaradaBrokering server and 400 receivers receive it. 12 of these clients run in the same machine as the sender client and the rest of the clients run in another machine. We gather the results from only those 12 clients, because if we run more clients in that machine, receivers introduce delays. This video stream has an average bandwidth of 600Kbps. So totally it takes up 240Mbps of network bandwidth. We compare the results of NaradaBrokering with the performance of a JMF reflector program written in Java. Figure 3 shows the measurement results:

Average delays/packet for 12 (of the 400 total) video-clients.
NaradaBrokering Avg=80.76 ms, JMF Avg=229.23 ms

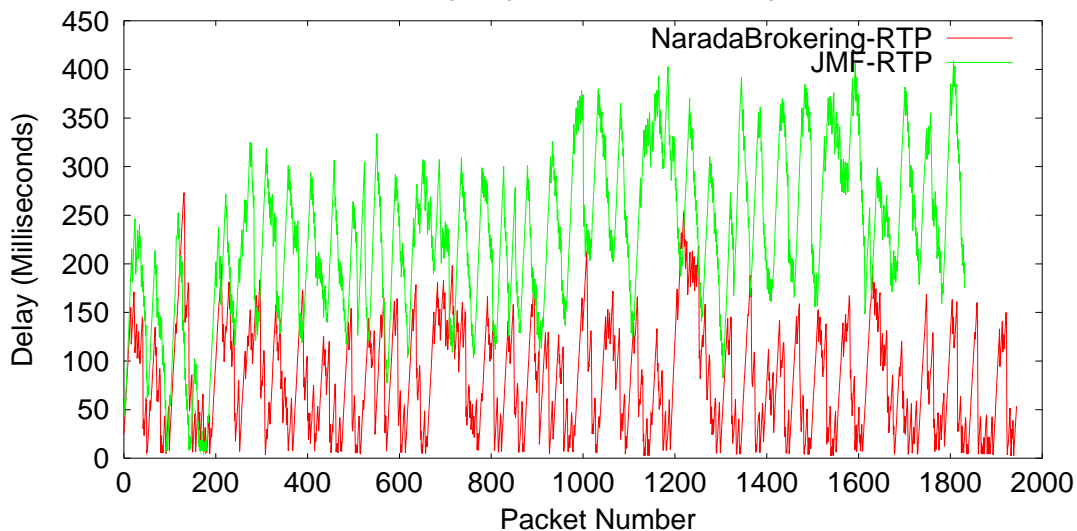

Average jitter/packet for 12 (of the 400 total) video clients.
NaradaBrokering Avg=13.38 ms, JMF Avg=15.55 ms

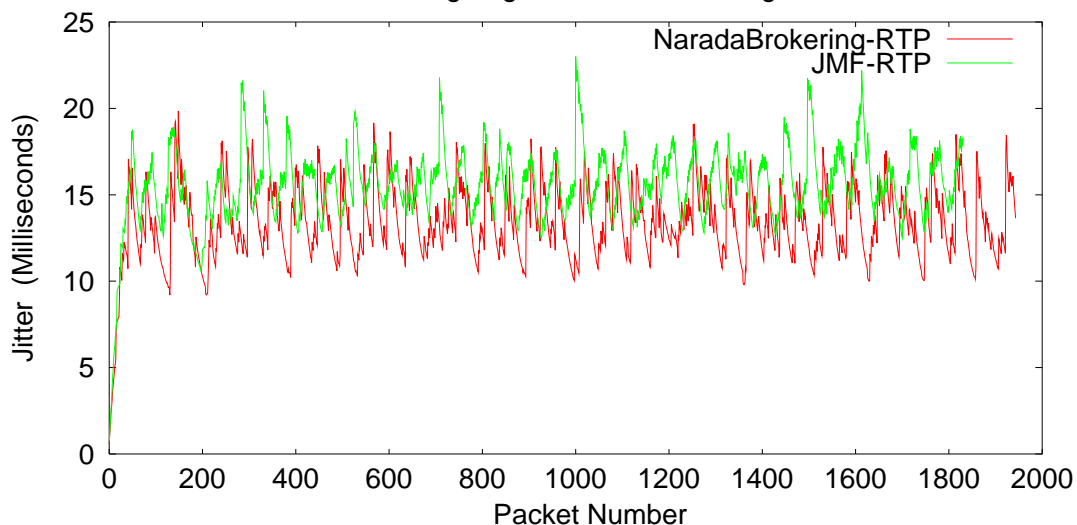

Figure 3 Comparison between the performance of NaradaBrokering and JMF

The tests we have conducted show that our messaging systems outpaces JMF reflector in the performance of delay and jitter. It is good enough to be used for large scale videoconferencing applications. And one broker can support more than a thousand audio clients or more than 400 hundred video clients at one time providing a very good quality.

Based on these XGSP servers and NaradaBrokering servers, Global-MMCS can support not only individual collaboration clients but also collaboration communities including AccessGrid, Admire, H.323 and SIP. For each community, we can define its collaboration web-services using WSDL, and implement these services based its own framework and protocol. There are two approaches to build RTP channels between these communities. For Admire community, XGSP Web Server invokes the web-services of Admire to notify the address of the rendezvous point. And Admire responds with its rendezvous point in SOAP reply. After that, both sides will create RTP agents on this rendezvous. For H.323 and SIP community, in addition to web-services commands, they have to rely upon H.323 and SIP Gatekeeper for signaling procedure, which means their RTP agents will be created through H.323 or SIP

5. Reference

- [1] Access Grid, <http://www.accessgrid.org>
- [2] Admire, <http://www.nlsde.buaa.edu.cn/projects/Admire>
- [3] Geoffrey Fox, Wenjun Wu, Ahmet Uyar, and Hasan Bulut A Web Services Framework for Collaboration and Audio/Videoconferencing, The 2002 International Multiconference in Computer Science and Computer Engineering, Internet Computing(IC'02), June 2002, Las Vegas
- [4] Geoffrey C. Fox and Shrideep Pallickara, "The Narada Event Brokering System: Overview and Extensions", proceedings of the 2002 International Conference on Parallel and

signaling procedure. We have built web-services of HearMe [6], a SIP based Voice-over-IP system. Similar interface can also be implemented based on other SIP or H.323 collaboration systems. Now we are co-operating with Admire research group to build Admire Web-services.

4. Related Work and Conclusion

There are some research works on bridging SIP and H.323 [8] [10]. But these projects only deal with interworking between one kind of A/V endpoint and another one. Columbia University group [8] defines the transformation of H.323 signaling procedure into SIP procedure and vice versa, which focus on VoIP service issue. And CMU group only implements a conference gateway [10] which connects multiple H.323 terminals and Mbone clients. They don't have an integrated web-service framework and distributed event service middleware for heterogenous collaborations.

In this paper, we presented the design and implementation of a Global Multimedia Collaboration System. Based on the XGSP framework, this system can provide the services of videoconferencing, instant messaging and streaming to various clients, and integrate different collaboration communities into a global collaboration platform.

Distributed Processing Techniques and Applications (PDPTA'02)

- [5] Hasan Bulut, Geoffrey Fox, Shrideep Pallickara, Ahmet Uyar and Wenjun Wu, Integration of NaradaBrokering and Audio/Video Conferencing as a Web Service, IASTED International Conference on Communications, Internet, and Information Technology, November 2002, US Virgin Islands.
- [6] HearMe Audio conference system, <http://www.hear.me.com>,
- [7] International Telecommunication Union, "Packet based multimedia communication systems", Recommendation H.323, Geneva, Switzerland, Feb. 1998.

[8] Jiann-Min Ho, Jia-Chen Hu, and etc, “A Conference Gateway Supporting Interoperability between SIP and H.323”, ACM Multimedia 2001, September, 2001.

[9] J. Rosenberg et al., “SIP: Session Initiation Protocol”, RFC 3261, Internet Engineering Task Force, June 2002, <http://www.ietf.org/rfc/rfc3261.txt>,

[10] K.Singh, H. Schulzrinne, “Interworking between SIP/SDP and H.323”, Proceedings of the 1st IP-Telephony Workshop (IP Tel'2000), April, 2000

[11] Steve Graham, Simeon Simeonov, etc, Building Web Services with Java, ISBN0-672-32181-5, Sams publishing.