

Syracuse University

SURFACE

Teaching and Leadership - Dissertations

School of Education

12-2012

Investigating Elementary Principals' Science Beliefs and Knowledge and its Relationship to Students' Science Outcomes

Uzma Zafar Khan
Syracuse University

Follow this and additional works at: https://surface.syr.edu/tl_etd



Part of the [Education Commons](#)

Recommended Citation

Khan, Uzma Zafar, "Investigating Elementary Principals' Science Beliefs and Knowledge and its Relationship to Students' Science Outcomes" (2012). *Teaching and Leadership - Dissertations*. 243.
https://surface.syr.edu/tl_etd/243

This Dissertation is brought to you for free and open access by the School of Education at SURFACE. It has been accepted for inclusion in Teaching and Leadership - Dissertations by an authorized administrator of SURFACE. For more information, please contact surface@syr.edu.

ABSTRACT

The aim of this quantitative study was to investigate elementary principals' beliefs about reformed science teaching and learning, science subject matter knowledge, and how these factors relate to fourth grade students' superior science outcomes. Online survey methodology was used for data collection and included a demographic questionnaire and two survey instruments: the K-4 Physical Science Misconceptions Oriented Science Assessment Resources for Teachers (MOSART) and the Beliefs About Reformed Science Teaching and Learning (BARSTL). Hierarchical multiple regression analysis was used to assess the separate and collective contributions of background variables such as principals' personal and school characteristics, principals' science teaching and learning beliefs, and principals' science knowledge on students' superior science outcomes. Mediation analysis was also used to explore whether principals' science knowledge mediated the relationship between their beliefs about science teaching and learning and students' science outcomes.

Findings indicated that principals' science beliefs and knowledge do not contribute to predicting students' superior science scores. Fifty-two percent of the variance in percentage of students with superior science scores was explained by school characteristics with free or reduced price lunch and school type as the only significant individual predictors. Furthermore, principals' science knowledge did not mediate the relationship between their science beliefs and students' science outcomes. There was no statistically significant variation among the variables. The data failed to support the proposed mediation model of the study. Implications for future research are discussed.

INVESTIGATING ELEMENTARY PRINCIPALS' SCIENCE BELIEFS AND KNOWLEDGE
AND ITS RELATIONSHIP TO STUDENTS' SCIENCE OUTCOMES

By

Uzma Zafar Khan

M.S., Syracuse University, 2004

M.P.S., SUNY Environmental Science and Forestry, 2004

Dissertation

Submitted in partial fulfillment of the requirement for the degree of
Doctor of Philosophy in Teaching and Curriculum

Syracuse University

December 2012

Copyright © Uzma Zafar Khan 2012
All Rights Reserved

ACKNOWLEDGEMENTS

It is difficult to begin this section without having to pause and recall all the individuals who have contributed to my well-being, happiness, and success. Without a doubt, the opportunities presented to me are a direct result of my parents' dedication and hard work for their children. Their choices in life have always centered on their children's education and future. I thank and love them from the bottom of my heart. They are the pillars of my success. I would also like to thank my dearest brothers, sister, sister-in-laws, nephews, and niece. Life has no meaning without family members to share it with. I would not trade a minute of our jovial get togethers. The encouragement, love, and joking around are truly priceless. Knowing that at the end of the day we all have each other's backs is the essence of life. I cannot thank you enough and imagine my life without all of you.

Similarly, I would like to express my gratitude to all my dear friends, colleagues, professors and peers in the doctoral program. The impromptu complaint and encouragement sessions helped me get through those tough days. We can do it! We just have to remember to remind each other.

I would also like to thank my committee members. I would not be capable of this endeavor without their guidance, persistence, and patience. Thank you for believing in me and providing your continued support via emails, Skype calls, and phone conversations. The knowledge and expertise provided by each of you leaves me in awe of you. I consider myself fortunate to be a part of your professional lives and can only hope to embody your high ethics and professionalism in my future endeavors. From today onwards, you will always be a part of me.

Finally, I would like to thank my husband. I love thee with the breath, smiles, and tears of all my life. You have taught me that there are no impossibilities in dreams and love. Your patience, support, acceptance, kind demeanor, and deep understanding for my choices are the cornerstone of my existence. I am incredibly blessed for being the half to your whole. For this, I am forever indebted to you. May no time of ours be wasted. May we be occupied in a useful pursuit!

TABLE OF CONTENTS

Abstract.....	i
Table of Contents.....	v
List of Tables.....	ix
List of Figures.....	x
Acknowledgments.....	xi
Chapter One: Introduction.....	1
Why Does Content Knowledge Matter?.....	2
Importance of Science Content Knowledge.....	4
Why do Beliefs About Reformed Science Teaching and Learning Matter?.....	5
Statement of Problem and Research Questions.....	6
Summary of Chapter One.....	9
Organization of the Study.....	10
Chapter Two: Review of Literature.....	12
Historical Perspectives of the Role of School Leadership.....	13
1980s - Instructional Leadership.....	15
1990s - Transformational Leadership.....	20
2000s - Shared Leadership.....	25
Professional Standards for School Leadership.....	35
Elementary Science Education.....	40
Importance of Elementary Science Teaching.....	40
Reformed View of Science Education.....	42
Inquiry Science Instruction and Student Outcomes.....	44
Current State of Elementary Science Teaching.....	48
Theoretical Framework.....	51
Instructional Leadership Theory.....	51
Leadership Content Knowledge.....	51
Implications for Principals.....	54
Conceptual Model.....	57
Antecedent with Mediated Effects Model.....	57
Summary of Chapter Two.....	61

Chapter Three: Methodology.....	63
Methods.....	64
Sampling and Participants.....	64
Design.....	66
Variables.....	66
Independent Variables.....	66
Type of School (urban, suburban, rural).....	66
Students’ Socioeconomic Status.....	67
Students’ Ethnicity.....	67
Principals’ Characteristics: Gender, Ethnicity, Total Years of Experience as Principal, Number of Years Principal in Current School, Total Years of Experience as Teacher, Subjects/Grades Taught, Degrees Held.....	67
Principals’ Beliefs About Reformed Science Teaching and Learning.....	67
Mediating Variable.....	67
Principals’ Science Content Knowledge.....	67
Dependent Variable.....	69
Students’ Grade 4 Science Outcomes.....	69
Instrumentation.....	72
Principals’ Demographic Questionnaire.....	72
Beliefs About Reformed Science Teaching and Learning Inventory (BARSTL).....	72
K-4 Physical Science Misconceptions Oriented Standards-Based Assessment Resources for Teachers (MOSART).....	77
New York State Grade 4 Elementary Level Science Test.....	80
Procedures.....	82
Analysis.....	87

Summary of Chapter Three.....	91
Chapter Four: Analysis and Results.....	92
Demographic Characteristics.....	94
Principals’ Demographic Questionnaire.....	94
School Contextual Information.....	96
Findings from Research Questions.....	99
Research Question 1: Does Principals’ Content knowledge in Science and Beliefs About Reformed Science Teaching and Learning Predict Students’ Superior Outcomes in Science Achievement Above and Beyond the Effect of Background Variables Such As Type of School, Student’s Socioeconomic Status and Ethnicity, Principal’s Gender, Ethnicity, Total Years of Experience As Principal, Number of Years Principal in Current School, Total Years Experience as Teacher, Subjects/Grades Taught, and Degrees Held?.....	100
Research Question 1a: What is the Level of Science Content Knowledge of Elementary School Principals as Determined by the K-4 Physical Science Misconceptions Oriented Standard- Based Assessment Resources for Teachers (MOSART) inventory?.....	100
Research Question 1b: What are Principals’ Beliefs About Reformed Science Teaching and Learning as Determined by the Beliefs About Reformed Science Teaching and Learning (BARSTL) inventory?.....	103
Research Question 1c: What are Students’ Superior Science Outcomes as Determined by the Percentage of Students Achieving a Performance Level 4 on the New York State Grade 4 Elementary-Level Science Test?.....	105
Pearson Correlations.....	107
Hierarchical Multiple Regression Results and Analysis.....	108
Bivariate Analysis.....	113

Research Question 2: Does Principals' Content Knowledge in Science Mediate the Relationship Between Their Reformed Beliefs About Science Teaching and Learning and Students' Outcomes?.....	113
Summary of Chapter Four.....	114
Chapter Five: Discussion, Limitations, and Conclusion.....	116
Introduction.....	116
Discussion.....	116
Findings.....	116
Strengths and Limitations.....	126
Strengths.....	126
Limitations.....	126
Response Rate.....	126
Population.....	127
Inventories.....	127
Dependent Variable.....	128
Future Research.....	130
References.....	133
Appendix A: Principal Survey.....	155
Appendix B: New York State Education Department Conversion Chart for Determining a Student's Final Science Test Score.....	169
Appendix C: New York State Grade 4 Elementary-Level Science Test.....	171
Appendix D: First Pre-Notification Email Message For Principals.....	191
Appendix E: Second Email Message For principals (Unique Survey Link).....	194
Appendix F: Follow-Up Email Message.....	197
Appendix G: 2008-2009 Statewide Accountability Report for New York State.....	200

List of Tables

Table 1: Comparisons Between ISLLC 1996 and 2008 Standards.....	39
Table 2: Description of Independent Variables.....	68
Table 3: Descriptive Statistics for Elementary School and Principal Demographic Variables.....	98
Table 4: Descriptive Statistics for Principal Years Experience and School Contextual Variables.....	99
Table 5: Pearson Correlations Among Variables.....	108
Table 6: Hierarchical Multiple Regression Analysis Summary for Principals’ Science Content Knowledge and Principals’ Beliefs About Reformed Science Teaching and Learning, Controlling for Antecedent Variables, Predicting Students’ Science Scores.....	110
Table 7: 2006 – 2011 New York Statewide Performance: Science, Math and ELA.....	132

List of Figures

Figure 1: Conceptual model of study.....	59
Figure 2: Mediation Model.....	89
Figure 3: Proposed Mediation Model of Study.....	90
Figure 4: Frequency Distribution of Principal’s MOSART scores.....	102
Figure 5: Frequency Distribution of Principal’s BARSTL scores.....	104
Figure 6: Frequency Distribution of Percentage of Students with Level 4 Scores.....	106

CHAPTER ONE

Introduction

According to the Institute for Educational Leadership, principals' responsibilities over the past century were predominantly managerial (2000). They ordered supplies, balanced budgets, ensured the safety of the staff and students, and complied with district guidelines. Although they are still responsible for these tasks, their roles have evolved considerably due to reform and accountability pressures (Bybee, 1993; Murphy, 2005; Rhoton, 2001). The No Child Left Behind (NCLB) legislation established the paradigm through which educational successes and failures are determined (NCLB, 2001; Parkinson, 2009). While NCLB was built on several assumptions, it was created as a means to improve student achievement within a structure of testing and sanctions (Orfield, Kim, Sunderman, & Geer, 2004). It attempted to address failing school outcomes by aligning federal, state, and local educational systems and holding them accountable for improving student achievement (Clune, 1998; Firestone, 2009; Johnson & Chrispeel, 2010; NCLB, 2001).

Consequently, principals' roles have become more complex (Timperley, 2006) as they are recognized as pivotal contributors within this mandate (Roach, Wes-Smith, & Boutin, 2011) by the instructional leadership demands placed on them (Fullan, 2003; Gentilucci & Muto, 2007). Within this era of accountability and increased coordinated communication among all agencies, principals are placed at the forefront of leading the improvement of teaching and learning in their schools (Hightower, Knapp, Marsh, & McLaughlin, 2002; Johnson & Chrispeel, 2010). Their strong instructional leadership is seen as one of the most salient factors in promoting student achievement (Togneri &

Anderson, 2003). Never before has the United States education system relied more heavily on the nation's nearly 84,000 principals to lead instructional improvements mandated by state and federal authorities (Kaplan, Owings, & Nunnery, 2005).

However, while the demands placed on school leadership have changed over the years, little progress in administrator preparation programs has occurred (Hale & Moorman, 2003). The U.S. Department of Education (2005) has characterized traditional programs as lacking vision, purpose, and coherence. There is a call for aligning research-based educational leadership practices associated with school improvement to contemporary leadership preparation programs (Hale & Moorman, 2003; Hess & Kelly, 2007). This changing context is prompting scholars to question whether traditional approaches to preparing principals are adequate (Elmore, 2000; Hess, 2003; Hess & Kelly, 2007) and if subject matter knowledge should be included in their training (Stein & Nelson, 2003).

Why Does Content Knowledge Matter?

As empirical studies continue to explore school leadership and understand best practice, researchers continue to assert that principals' behaviors are positively correlated to student achievement (Waters, Marzano, & McNulty, 2003) and that there is a link between the two (Hallinger, 2008, 2011). Given these findings, policy makers and educational experts are developing strategies to improve schools and ultimately student achievement by developing school leaders who can promote effective teaching practices and learning for all students (Bottoms & O'Neill, 2001; Farkas, Johnson, Duffett, & Foleno, 2001; Orr & Orphanos, 2011). Principals are under intense pressure to fulfill the

role of instructional leader and implement standards-based reform in the 21st century (Hale & Moorman, 2003).

An instructional leadership role demands that principals become knowledgeable about and supportive of instructionally sound methods and be able to discern between effective and ineffective teaching and learning (McGhee & Lew, 2007). The Institute for Educational Leadership (2000) recommends “principals must serve as leaders for student learning. They must know academic content and pedagogical techniques. They must work with teachers to strengthen skills. They must collect, analyze and use data in ways that fuel excellence (p. 2).” Within this mandate, principals can no longer delegate responsibilities related to standards, assessments and the learning needs of students to teachers without also being knowledgeable about it themselves (Daly, 2009; Hale & Moorman, 2003).

As scholars concur that principals need to be effective instructional leaders, they propose that a missing construct in the analysis of school leadership and student achievement is principal’s subject matter knowledge (Spillane & Seashore-Louis, 2002; Stein & Nelson, 2003). Stein and Nelson (2003) refer to this knowledge as Leadership Content Knowledge. Leadership Content Knowledge is described as knowledge of academic subjects that is used by administrators in order for them to function as strong instructional leaders. However, since most principals cannot serve as subject-area specialists, except in the area that they obtained teaching certification, Leadership Content Knowledge will help them facilitate the supervision of subject matter reforms to improve student achievement (Burch & Spillane, 2003). It will also facilitate their ability to understand the learning needs of their teachers and students and create an environment

that embodies the right mix of expertise with adequate resources to support learning (Stein & Nelson, 2003). Hence, Leadership Content Knowledge will support principals to recognize strong instruction when they see it, encourage teachers when they do not see it, and provide a culture in which teachers and students can be academically successful (Burch & Spillane, 2003; Stein & Nelson, 2003).

Importance of Science Content Knowledge

As the role of instructional leadership is gaining momentum, many scholars have noted that mathematics and science education require more attention from school leaders (Rice & Islas, 2001). Almost every major document that advocates for science education reform has included the role of principals as a necessary component for success (American Association for the Advancement of Science, 1993; National Research Council, 1996, 2002; National Science Foundation, 1996; Weiss, Knapp, Hollweg, & Burrill, 2001). The role of principals is critical to the successful implementation of education standards (Chance & Anderson, 2003; Partlow, 2007). This is especially important for elementary principals since science has become a low priority in elementary schools (Conderman & Woods, 2008). Elementary science teaching remains sporadic and tends to be a fringe subject that is taught when time allows (Spillane, Diamond, Walker, Halverson, & Jita, 2001). This is problematic since elementary students need access to good science instruction as early as possible (Mulholland & Wallace, 2005).

In addition to the poor state of elementary school science teaching (Appleton & Kindt, 2002), multiple reports indicate that U.S. students' science scores are measurably lower than their counterparts in several other developed nations (Baldi, Jin, Skemer,

Green, & Herget, 2007; Gonzales et al., 2008; Hardy, 2005; Snyder, 2008). The Program for International Student Assessment (PISA), an internationally standardized assessment that measures 15-year olds' performance in reading literacy, mathematics literacy, and scientific literacy, revealed that 16 Organization for Economic Cooperation and Development (OECD) countries had measurably higher scores in science than U.S. students in the recent past (Bybee, 2007). The 2009 PISA science results presented similar findings. Among 65 countries that participated in the assessment, 22 countries had higher science scores than the United States (OECD, 2011).

The United States continues to rank average in science, suggesting a need to improve in an economy where scientific literacy is paramount to sustaining global competitiveness (Bybee, 2007; Marx & Harris, 2006). However, despite these results, subjects other than science continue to receive more attention in elementary schools (Smith & Neal, 1991; Spillane et al., 2001). These reports of students' science knowledge, along with the recommendations outlined in the science reform documents, compel elementary principals to provide effective science instructional leadership. Their influence can help teachers develop and maintain effective standards-based instruction (Hale & Moorman, 2003; Rhoton, 2001). Many researchers consider principals indispensable for successful science reform efforts in schools (Burch & Spillane, 2003; Elmore, 2000; Hale & Moorman, 2003; Spillane, 2005; Rice & Islas, 2001).

Why Do Beliefs About Reformed Science Teaching and Learning Matter?

Research suggests that principal actions are informed by, but not limited to, their beliefs about leadership and responses to district and state policies (Youngs, 2007). They move through stages of attitudes and beliefs as they explore new roles of administrative

leadership and embrace reform (Lieberman & Miller, 1990). Most often, their beliefs are characterized as and manifested in their tentative “vision” for school leadership.

Therefore, in order to heed the call to effectively embrace reform without compromising the intent of the reform movement, understanding principal’s personal philosophy of reformed science teaching and learning cannot be underestimated.

Since most principals ascend to their current administrative positions from being teachers themselves, previous research on teachers’ beliefs should be utilized to examine principals’ beliefs in the implementation of reform recommendations. Research on teachers’ beliefs has well established the relationship between beliefs and teachers’ behavior (Calderhead, 1996; Pajares, 1992). Scholars assert that teachers’ practices tend to be consistent with their belief system (Cronin-Jones, 1991; Joram & Gabriele, 1998; Sampson & Benton, 2006). Therefore, it is not prudent to examine principals’ science content knowledge without acknowledging the role of their beliefs about reformed science teaching and learning. If alignment of philosophical stances is needed among instructional leaders and reform documents to understand, promote, and support a standards-based science curriculum, then these findings can inform administrator preparation and professional development programs.

Statement of Problem and Research Questions

Within the large amount of research on principal leadership, its effects on student learning outcomes remains poorly understood (Hallinger, Bickman, Davis, 1996). Among the confluence of school principal efficacy literature and the challenges associated in the field of educational administration (Roach et al., 2011), interest in instructional leadership and how it influences instruction and student outcomes persists (Robinson,

Lloyd, & Rowe, 2008). Scholars continue to agree that principals have measureable effects on school effectiveness (Hallinger & Heck, 1996a; Witziers, Bosker, & Kruger, 2003). They also agree on the importance of school leadership and principal subject matter knowledge, but acknowledge that there is limited understanding of how these factors interact (Burch & Spillane, 2003).

The changing context of accountability pressures for principals to be instructional leaders, coupled with national efforts to improve science teaching and learning, warrants the examination of challenges associated with implementing standards-based reform. Determining possible options for action, and ultimately creating coherent systems for supporting principals to effectively implement standards-based reform, demands the examination of their science content knowledge and philosophical stance. Since principals are in a position to provide meaningful support for implementing effective science instruction and are entrusted with leading instructional improvement, understanding factors that may contribute in helping them be effective is essential. It is not alarming that “principals themselves are among the first to agree that they need to be more effectively prepared for their jobs. All but four percent of practicing principals report that on-the-job experiences or guidance from colleagues has been more helpful in preparing them for their current position than their graduate school studies” (Hess & Kelly, 2007, p. 3).

Based on this need, the aim of this study is to understand the nature of elementary school principals’ science subject matter knowledge and beliefs about science teaching and learning by examining their relationship to students’ science achievement. The percentage of students achieving a state-designated level four in science will be used as

the measure for students' science achievement. New York State's Department of Education reports students' science achievement as percentage of students achieving one or more of four state-designated levels of performance. Specifically, level 1 represents students with a final test score range of 0-44, level 2 represents a final test score range of 45-64, level 3 represents a final test score range of 65-84, and level 4 represents a final test score range of 85-100. For the purpose of this research, the percentage of students achieving a level 4 in science was used as the dependent variable. Level 4 was selected for several reasons that will be discussed in detail in Chapter Three. Students' science performance at this level was designated by the state as: (a) *Meeting the Standards with Distinction*, (b) demonstrating superior understanding of elementary-level science content, concepts, and skills for the learning standards and key ideas being assessed, and (c) having a test score range of 85-100. Therefore, my research questions are:

1. Does principals' content knowledge in science and beliefs about reformed science teaching and learning predict students' superior science outcomes above and beyond the effect of background variables such as type of school, student's socioeconomic status and ethnicity, principal's gender, ethnicity, total years of experience as principal, number of years principal in current school, total years experience as teacher, subjects/grades taught, and degrees held?
 - a. What is the level of science content knowledge of elementary school principals as determined by the Physical Science Misconceptions Oriented Standards-Based Assessment Resources for Teachers (MOSART) inventory?

- b. What are principals' beliefs about reformed science teaching and learning as determined by the Beliefs About Reformed Science Teaching and Learning (BARSTL) inventory?
 - c. What are students' superior science outcomes as determined by the percentage of students achieving a performance level four on the New York State Grade 4 Elementary-Level Science Test?
2. Does principals' content knowledge in science mediate the effects of their beliefs about science teaching and learning in predicting students' superior science outcomes above and beyond the effect of background variables such as type of school, student's socioeconomic status and ethnicity, principal's gender, ethnicity, total years of experience as principal, number of years principal in current school, total years experience as teacher, subjects/grades taught, and degrees held?

The results of this study will inform science instructional leadership practice in ways that will increase and support science instruction in elementary schools. Furthermore, since studies of elementary school leadership and subject matter knowledge are scarce (Burch & Spillane, 2003), the findings from this study will contribute to the development of a knowledge base in science instructional leadership. This in turn may lead to lasting improvement in principal preparation programs and ultimately create better qualified instructional leaders.

Summary of Chapter One

This study will determine the relationship of principals' beliefs about reformed science teaching and learning, principals' science knowledge, and students' superior

science outcomes. In an era where principals continue to be cited as instructional leaders or lead teachers and bear the burden for improved academic achievement, this study will determine the role of their science beliefs and knowledge on students' science outcomes. This is the first study to examine principals' science beliefs and knowledge using the BARSTL and MOSART inventories, respectively. As the science education and leadership communities continue to place principals at the forefront of students' science achievement, little research intersects at these two domains. This study will attempt to fill this gap in the current literature by exploring the constructs of principals' science beliefs, science knowledge, and students' science outcomes.

Organization of the Study

The following provides a summary of this dissertation. Chapter One provides the core rationale for this study by highlighting its necessity. It situates the study within the present era of accountability and the role of principals as instructional leaders. Chapter Two includes a review of literature on the expansion of the role of school leadership from its historical perspectives to the present. It highlights the ideological and practical challenges inherent in the field of school leadership and its supporting agencies. It also reviews empirical research investigating the role of instructional leadership and student outcomes and the need to study science instructional leadership. Finally, it connects the conceptual model of this study to the research questions. Chapter Three includes information on the design and methodology used in this study. It provides detailed information of the variables used in the study and methodological decisions. Chapter Four presents the results and analysis of the study and how to interpret the findings

within the context of this research. Finally, Chapter Five consists of discussion of the findings, the strength and limitations of the study, and future recommendations.

CHAPTER TWO

Review of Literature

Chapter Two elaborates on the evolution of the role of school leadership and how researchers have attempted to identify a knowledge base in the field. It begins with a historical perspective of school administration beginning in the early 1900s and continues to different eras that led to the emergence of two epistemologies that, some argue, still exist today. In order to establish a comprehensive context in which this study is situated, this chapter (a) focuses on the role of school leadership in a logical progression from 1980 to present, (b) reviews the role of principals within the emergence of new leadership models, such as instructional, transformational, and shared leadership within the context of student outcomes (c) reviews designated professional standards for principals, (d) reviews elementary science education: specifically focusing on the importance of elementary science teaching, the reformed view of science teaching and learning, inquiry science instruction and student outcomes, and the current state of elementary science teaching, (e) reviews the theoretical framework applied to this study, (f) describes the implications for principals within this context, and ends with (g) the application of a conceptual model that this study is built upon.

This review of literature provides the rationale in which this study is situated and explains how it extends previous work in the field. It highlights the changing role of school leadership in an era of accountability and sanctions. This review explains the intersection of leadership and elementary science education. The research questions in this study address calls for research exploring principals' science content knowledge and its relationship to students' science outcomes. Since research in this domain is in its

infancy, the questions are designed to establish a knowledge base and inform best practice for the preparation of future principals. The variables used in this study are based upon previous research in instructional leadership and are identified in Chapter Three. Furthermore, since school organizations are dynamic systems and the actions and behaviors of principals are guided by the ideological, social, and political contexts surrounding their schools (Evans, 2007), the variables selected are sensitive to these issues and representative of these contexts.

Historical Perspectives of the Role of School Leadership

In the early 1900s, there was a joint effort by scholars and practitioners to achieve professionalism in school administration (Kowalski, 2009). A prescriptive era in school administration emerged that spanned from 1900-1946 (Campbell, Fleming, Newell & Bennion, 1987). America was a business society in the 1920's and its citizens wanted their schools run in a businesslike way with school administrators taking on the role of "school executive" (Callahan, 1966). At the same time, professors were designing new courses to reflect the principles of business management to school administration (Callahan, 1962). Studies on schools were being conducted, scholarly publications were on the rise, and collaborations were underway with professional organizations such as the American Association of School Administrators (Kowalski, 2009). New textbooks appeared in educational administration that focused on the organizational, legal, and mechanical aspects of administration with an unscientific and non-theoretical approach (Murphy, 1995).

These conceptions of school administration resulted in a crescendo of criticism during the prescriptive era (Murphy, 1995). The rise of the businessman as a leader of

schools, due to the capitalist society under which industrialism developed in America, was seen as an inappropriate philosophy (Callahan, 1962). However, the criticism accomplished little in way of changing the knowledge base by the end of the prescriptive era. The knowledge base was still comprised of folklore and testimonials of reputedly successful administrators (Murphy, 1992). Personal accounts of experienced practitioners (Silver, 1982) and “preachments to administrators about ways in which they should perform” (Goldhammer, 1983, p. 250) were the norm.

These perceptions of the knowledge base demanded fundamental changes in the intellectual conceptualization of the profession and ushered in the behavioral science era that spanned from 1947-1985 (Murphy, 1995). After WWII, an effort was underway to establish a science for educational administration referred to as the “theory movement” (Kowalski, 2009). This movement supplanted the existing knowledge base with theoretical, conceptual, and empirical material from the social sciences (Murphy, 1995; Callahan, 1966). Educational administration textbooks started to focus on theory (Getzels, 1977) and the field was starting to be viewed as an applied science that linked theory, research, and practice (Crowson & McPherson, 1987). This movement borrowed and adopted research techniques and instruments from the behavioral sciences (Culbertson, 1965). School administration was becoming an applied science within which theory and research were “directly and linearly linked to professional practice [in which] the former always determine the latter, and thus knowledge is super ordinate to the principal and designed to prescribe practice” (Sergiovanni, 1991, p. 4).

The mechanical aspects of leadership responsibilities fell into disfavor. The behavioral science movement renewed hope towards the development of a cognitive

foundation for educational leadership (Murphy, 1992). However, tensions emerged between the social sciences and educational administration as new theories of science and pressures from policy research emerged (Culbertson, 1988). Conflict among professors was apparent during the mid-1970's, which resulted in the development of two epistemologies in educational leadership (Donmoyer, 1999). One epistemology focused on primarily practice-based knowledge while the other was based on espoused theories (Murphy, 2002). As a result, a "big tent" strategy evolved that allowed everyone to define his or her own meanings in school administration (Donmoyer, 1999). Scholars agreed to disagree and conducted research from their own paradigms. This promoted multiple definitions of knowledge and measures of success in educational leadership (Murphy, 2002). A coherent leadership model was needed in the field as the instructional leadership model emerged in the coming decade.

1980s - Instructional Leadership

The reform movement of the 1980s focused more attention on educational roles of school leaders than previous reform efforts (Murphy, 1988). An instructional leadership model emerged in this decade from effective schools studies that placed an emphasis on the role of principals (Hallinger, 2007; Pink, 1984). The effective schools studies suggested that school structures should conform to bureaucratic organizations with a solitary manager emphasizing goals and monitoring behaviors (Cohen & Miller, 1980). This resulted in a new set of demands for principals, as their role was being re-conceptualized, and laid the groundwork for more empirical investigation (Bossert, Dwyer, Rowan, & Lee, 1982; Hallinger & Murphy, 1985a). During this time, policymakers focused on issues of educational productivity and cast the role of principal

impact in terms of effects on student learning (Hallinger & McCary, 1990). Scholars responded by generating a substantial body of research that focused on direct and indirect effects of instructional leadership and its relationship to student achievement (Ogawa & Hart, 1985). Direct effects leadership behavior constituted principals working individually with teachers to promote improved instruction while indirect leadership behaviors manifested in setting school-wide goals and expectations that shaped and controlled the school environment (Hallinger, Murphy, Weil, Mesa, & Mitman, 1983). As a result, researchers conducted studies on the direct and indirect effects of principals on student achievement and designed checklists of principal job behaviors, tools for assessing these behaviors, and frameworks for examining instructional leadership (Hallinger & Murphy, 1987a).

A meta-analysis on effective instructional management studies resulted in the development of a framework for understanding the role of the principal as an instructional manager (Bossert et al., 1982). Bossert et al. (1982) were among the first scholars to present a model that described how certain leadership acts translated into concrete activities that contributed to student achievement. Upon reviewing studies of effective principals and successful schools, they identified four areas of principal leadership: (a) goals and production emphasis, (b) power and decision-making, (c) organization/coordination, and (d) human relations. They suggested effective educational leaders that embodied these four principles of leadership emphasized achievement, were more active than their colleagues in ineffective schools in the area of curriculum and instruction, devoted more time to the coordination and control of instruction, were more skillful at the tasks involved, recognized the unique styles and needs of teachers, and

assisted teachers in achieving their performance goals. The authors concluded that the managerial behavior of principals was still important to school effectiveness and presented a framework that incorporated the relationship between leadership and school.

Within this framework, principal instructional management behavior was envisioned as affecting the school climate and the organization of schooling as a social process. It set the context in which social relationships were formed and teacher behaviors and student learning experiences were shaped. In turn, principal instructional management behavior was also susceptible to being shaped by personal, district, and external characteristics. This framework was the first to highlight the social processes and structures within a school that contributed to student achievement. It implicated that principal instructional management behavior had both direct and indirect effects on student learning.

Hallinger and Murphy (1985a, 1987b) were among the first scholars who conducted studies that described instructional management behaviors of principals in terms of their specific job functions. They developed an instructional leadership framework and an appraisal instrument to assess these behaviors and functions. Hallinger and Murphy (1985b, 1987a, 1987b) sought to study a single school district that included 10 elementary school principals, 104 teachers, and 3 district office supervisors to examine the instructional management behavior of principals. They designed a questionnaire to generate descriptions of behaviors by using three general dimensions of effective instructional leadership from effective schools studies: (a) defining the mission, (b) managing the instructional program and, (c) promoting the school learning climate (Hallinger et al., 1983). In addition to the questionnaire, documents were also used to

generate descriptions of principal behaviors. The documents consisted of supervisory assessments based on observations of principals, teacher evaluation reports written by principals, school goal statements, principal newsletters, memos and bulletins, school handbooks, faculty meeting agendas and minutes, and narrative reports submitted by principals that described what they did to manage curriculum and instruction in their schools.

Upon analysis of the descriptions generated by the data, the authors narrowly defined job functions implemented by principals by way of direct or indirect activities. They included: (a) frames goals, (b) communicates goals, (c) knows curriculum and instruction, (d) coordinates curriculum, (e) supervises and evaluates, (f) monitors progress, (g) sets standards, (h) sets expectations, (i) protects time, and (j) promotes improvement. These job functions constituted the conceptual definitions for the principal variables they examined and were further used to construct behaviorally anchored rating scale items for the development of the Principal Instructional Management Rating Scale (PIMRS). The PIMRS consisted of 11 sub-scales and 71 items, and was used to measure the frequency of 50 specific instructional leadership behaviors exhibited by principals as perceived by the faculty.

Hallinger and Murphy (1985b, 1987a) contributed a list of specific job functions of effective principals, the PIMRS assessment tool, and an instructional leadership framework to the newly defined instructional leadership role of principals. However, the knowledge base in educational administration was still seen as incomplete. Efforts to define instructional leadership led to specification and categorization of concrete behaviors (Murphy, 1988). Lists of administrator functions were created without a sense

of how and when to perform them (Murphy & Hallinger, 1985; Hallinger & McCary, 1990). The dearth of well-designed studies of principal impact led to inaccurate conclusions (Murphy, 1988; Murphy, Hallinger, & Mitman, 1983; Rowan, Dwyer, & Bossert, 1982). A model of the educational leader as the independent variable in school leadership emerged (Boyan, 1988) that implicated the principal as the cause of effective schools despite the absence of research to support this claim (Rowan et al., 1982). There was a growing realization that studies in educational administration informed by the social sciences and conducted during this time period produced inadequate results in terms of administrative practice (Blumberg, 1984). The instructional leadership literature continued to suffer from a lack of research in defining a knowledge base (Smith & Muth, 1985). At the same time, there was a call for grounded theories and ecologically valid research that emphasized examining principal effects on both mediating and outcome variables (Murphy, 1988). The need for a knowledge base was also strongly recommended by the National Policy Board for Educational Administration (Scheurich, 1995).

To fill this gap, scholarly articles surfaced in the field that introduced the concept of strategic thinking that underlies instructional leadership (Firestone & Wilson, 1985; Leithwood & Montgomery, 1982). Hallinger and McCary (1990) attempted to link strategic thinking to the defined instructional leadership behaviors. They examined the research on instructional leadership and presented a rationale for viewing principal leadership from a strategic thinking perspective. They then linked the research to the training and development of principals by advocating a problem-based learning model for students in educational administration programs. The anecdotal problem-based training

program was organized around problems principals faced in schools within the context of the subject matter. Hallinger and McCary (1990) incorporated context specific problems into computer simulations that required interdependent actions by principals. These problems were intended to force learners to engage in strategic thinking. Examples of some of the problem scenarios were to solve low fourth grade test scores in an elementary school and to maximize student achievement through the expenditure of available resources. Scenarios were intended to supplement coaching sessions to motivate learners and reinforce their knowledge. Hallinger and McCary (1990) advocated incorporating this model of training into the field of educational administration despite the lack of empirical evidence to support it. They noted that research from other fields benefited by embedding learning in problem-based formats. However, little progress was made towards a strategic thinking model in educational leadership as a new era was approaching.

1990s - Transformational Leadership

In the beginning of a new decade, there were still perceived limitations of the instructional leadership model. A need for further research in conceptualizing the role of the administrator and its knowledge base was still present. Democratic and collaborative approaches to instructional leadership were needed (Glickman, 1992). As a result, the 1990s ushered in a transformational leadership model in school administration (Leithwood, 1994). Glickman (1992) referred to the model as a collaborative effort among teachers and administrators within a supportive environment that would lead to the improvement of schools. Reitzug and Cross (1993) defined principals' emerging role as a facilitator in improving teacher practice. The transformational leadership model

redistributed power and responsibility from the principal and moved away from a focus on a single leader (Leithwood, 1994). Capacity building replaced leading, directing, and controlling learning. These ideas were further reinforced and gained legitimacy when Hallinger and Heck (1996b) conducted a review of instructional leadership studies between 1980-1995.

Hallinger and Heck (1996b) reviewed empirical literature on the relationship between the role of principal and school effectiveness published between 1980-1995. The review included worldwide journal articles, dissertation studies, and papers presented at peer-reviewed conferences. The criteria for inclusion of studies were: (a) they had to have been designed explicitly to examine the effects of principal leadership beliefs and behavior and measured principal leadership as one of the independent variables, (b) they had to include an explicit measure of school performance as a dependent variable such as student achievement, (c) and include principal impact on teacher and school level variables as mediating factors. Using these criteria, 40 studies were identified that used a cross-sectional, correlational design. The studies were analyzed within a classification system adapted from Pitner's (1988) theoretical classification system. The conceptual models within the classification system were a direct-effects model, a mediated-effects model, an antecedent-effects model, and a reciprocal-effects model.

The direct-effects model proposed that principal effects on school outcomes occurred in the absence of intervening variables. This was considered a weak model as it was subject to making untenable claims and revealed little about how leadership operates. The mediated-effects model took into account that the impact attained by principals occurred by way of their interaction with the school. It assumed that principals achieved

their results through other people and therefore, this model contributed more to theory building. The antecedent-effects model viewed the principal as both a dependent and independent variable. As a dependent variable, principal behavior was subject to the influence of other variables within the school and as an independent variable, the principal was able to impact teachers, student learning, and school outcomes. Finally, the reciprocal-effects model viewed principals as adapting to the organization in which they worked and ultimately this adaptation changed their thinking and behavior over time.

Hallinger and Heck (1996b) recognized that the studies included in their review progressed from simple, direct-effects model to a more inclusive model where antecedent variables were included within a mediated-effects model. They referred to this as a paradigm shift in the conceptualization of educational leadership and claimed that the effects of leadership on students were largely indirect. Student learning was indirectly influenced by principals who exercised their authority in internal school processes such as school policies, academic expectations, school mission, and instructional organization through the practices of teachers and other school personnel. This was seen as empowering principals rather than diminishing their roles: achieving results through others was the essence of transformational leadership.

As a result, scholars conducted studies incorporating different frameworks to better understand the role of principals. Hallinger et al. (1996) conducted a study using an antecedent and outcome framework to understand the nature of principal leadership in school improvement, specifically student achievement. They tested this model of principal effects on student learning by conducting a secondary analysis of data collected from 98 elementary schools in Tennessee. The researchers used teacher and principal

questionnaires, student test scores, and data on contextual factors (student SES, parental involvement, principal gender, teaching experience) to examine relationships between school context variables, principal instructional leadership, instructional climate, and student reading achievement. Path analysis was used to test the assumptions of causality in these variables. Findings indicated that parental involvement in school had a positive effect on principal leadership, principals in higher SES schools exercised more active instructional leadership than their counterparts in schools serving students of lower SES, female principals were perceived as exercising more instructional leadership by teachers than their male counterparts, and positive indirect effects of principal leadership on student achievement in reading was found. A causal link was revealed between the school climate variables and the school contextual variables that indicated a statistically significant positive relationship ($p < .01$) between principal leadership and school climate variables. The school climate variables in turn had a positive effect on student achievement in reading ($p < .05$).

As a result, Hallinger et al. (1996) stated that viewing instructional leadership within a framework of antecedents and outcomes variables provided a powerful lens for understanding the role of principal as it portrayed principal effects on student achievement as occurring through intervening school climate variables. They asserted the need to abandon the direct effects framework for studying the role of educational leadership in future research endeavors. Their study supported the notion that principals played an important role in school effectiveness and emphasized that understanding the indirect effects of principals could not be achieved without working with staff, parents,

students, and teachers. Scholars were encouraged to conduct studies using this framework and include all members of the school community in their research frameworks.

Blase and Blase (1999) heeded the call to the re-conceptualization of educational leadership and were the first to conduct a comprehensive, in-depth, mediated effects study on effective instructional leadership behaviors from the perspective of teachers. They interviewed teachers regarding the characteristics of principals that enhanced their classroom instruction and in turn the impact those characteristics had on them as teachers. The data were drawn from open-ended questionnaires given to more than 800 teachers from all three school levels from rural, suburban, and urban districts. An inductive analysis of the data resulted in the development of a Reflection Growth (RG) model of instructional leadership with two major themes: (a) principals talking with teachers to promote reflection and (b) principals promoting professional growth. The first theme of principals talking with teachers to promote reflection encompassed principal strategies such as making suggestions, giving feedback, modeling, using inquiry and soliciting advice and opinions from teachers, and giving praise. The second theme of promoting professional growth encompassed principal strategies such as: emphasizing the study of teaching and learning, supporting collaboration, developing coaching relationships, supporting program redesign, applying the principles of adult growth and development to all phases of teacher development programs, and using action research.

Blase and Blase (1999) indicated that theoretically their data (strategies) had strong enhancing effects on teachers emotionally, cognitively, and behaviorally. They cited that teachers from their sample described positive strategies used by principals that in turn had positive effects on their classroom instruction. Blase and Blase (1999)

suggested that the RG model was unique as it described effective instructional leadership behaviors and their effects on teachers from the perspectives of teachers. This study engaged and valued teacher voices in regards to effective leadership. This concept contributed to the evolving conception of instructional leadership in the coming decade.

2000s – Shared Leadership

In the emerging era of accountability, principals felt increased pressure to concentrate their efforts on instructional improvement (Firestone & Riehl, 2005). Similarly, scholars were trying to make sense of research and determine best practice. Consequently, Hallinger (2011) conducted a review of over 80 doctoral dissertations from the United States of America, Canada, Philippines, Hong Kong, Thailand, Taiwan, and Cameroon conducted between 1982 and 2000 that used the Principal Instructional Management Rating Scale. He concluded that the studies contributed little to the knowledge base of principal management and leadership. These findings mirrored research conducted during the 1960s and later in the 1980s (Hallinger & Heck, 2005). Hallinger and Heck (2005) stated that, “much more attention is currently being given to comment and critique than to progressive empirical study that demonstrates the impact of strategies to alleviate educational problems, regardless of methodological perspective” (p. 236).

These studies Hallinger (2011) reviewed did not focus describing the problems principals had in their practice or on their solutions. The instructional leadership model of the 1980s viewed the principal as an expert whose role centered on maintaining high expectations for teachers and students (Murphy & Hallinger, 1985). The burden of effective school leadership was solely on the principal (Hallinger, 2003). The 1990s

encouraged the development of collective capacity with teachers and all stakeholders, and ushered in the transformational leadership model (Hallinger, 1992). Although the transformational leadership model was an improvement from previous models it lacked an instructional leadership component (Hallinger & Leithwood, 1998). While focusing on collaboration, transformational leadership lacked an explicit focus on curriculum and instruction (Hallinger & Heck, 1998). A new leadership model was needed to further supplant the knowledge base of instructional leadership.

With the turn of the century, as the standards movement and new forms of assessments were put in place, principals were faced with competing priorities (Murphy, 2005). The broadened responsibilities of accountability posed challenges for a solitary principal (Darling-Hammond, 1997). A new conception of educational leadership was needed to help principals disperse their responsibility for leadership functions across school members while maintaining a focus on teaching and learning (Camburn, Rowan, & Taylor, 2003; Marks & Printy, 2003). As a result, a new leadership model emerged referred to as shared instructional leadership (Hallinger, 2003).

Shared (also referred to as distributed or collective) instructional leadership involved principals and teachers in shared decision making while they collectively worked as a community of learners in service to students (Blase & Blase, 1999). Teachers were empowered and provided with opportunities to grow and exercise instructional leadership (Blase & Kirby, 2000). As Poole (1995) stated, the role of the principal became one of facilitator of teacher growth rather than an evaluator of teacher competence. The shared instructional leadership model particularly emphasized the role of the principal within a team of other administrators and teacher leaders in matters of

curriculum and instruction (Marks & Printy, 2003). It essentially embodied the ideas of the previous leadership models while adding a focus on curriculum and instruction.

During the emergence of the shared instructional leadership model, several prominent studies were conducted that require attention. In a meta-analysis, Cotton (2003) reviewed 81 leadership studies conducted between 1985-2000. The inclusion criteria for the meta-analysis included studies that focused on principal behaviors in relation to one or more student outcomes such as student achievement, attitudes, and social behavior. The studies included empirical research, reviews, textbook analyses, summaries, and research-based guidelines. Upon analysis, Cotton (2003) identified 26 essential traits and behaviors of effective principals that contributed to positive student outcomes: principals focused on high levels of student learning, maintained high expectations within a positive school environment, and shared leadership and empowered the staff. Cotton (2003) categorized principal behaviors into five themes that included: (a) establishing a clear focus on student learning, (b) establishing and maintaining quality interactions and relationships, (c) shaping school culture, (d) serving as an instructional leader, and (e) ensuring accountability. The author concluded that strong administrative leadership was a key component of schools with high student achievement irrespective of student background or socioeconomic status. Although Cotton's (2003) findings identified a list of behaviors, she emphasized that effective principals embodied all or nearly all of these traits and actions.

During the same time, Waters et al. (2003) conducted a meta-analysis on the effects of leadership practices on student achievement. They analyzed studies, including dissertations that purported to examine the effects of leadership on student achievement

since 1970. From a total of more than 5000 studies during this period, 70 met their criteria for design, controls, data analysis, and rigor. The inclusion criteria of the studies were: (a) quantitative student achievement data, (b) student achievement measured on a standardized, norm-referenced test or some other objective measurement of achievement, (c) student achievement as the dependent variable and, (d) teacher perceptions of leadership as the independent variable. The 70 selected studies involved 2,894 schools, approximately 1.1 million students, and 14,000 teachers.

Upon analysis, Waters et al. (2003) found 21 specific leadership responsibilities, and their associated practices, that significantly correlated with student achievement. Principal leadership responsibilities were: (a) fosters sense of community of culture, (b) establishes a standard order, (c) discipline, (d) resources, (e) directly involved in the design and implementation of curriculum, instruction, and assessment, (f) maintaining focus by establishing clear goals, (g) foster shared beliefs in knowledge of curriculum, instruction, and assessment, (h) visibility, (i) contingent rewards, (j) communication, (k) outreach, (l) input, (m) affirmation, (n) relationship, (o) change agent, (p) optimizer, (q) ideals/beliefs, (r) monitors/evaluates, (s) flexibility, (t) situational awareness and, (u) intellectual stimulation. The average effect sizes of the leadership responsibilities on their impact on student achievement ranged from .15 -.33. They translated their findings into a balanced leadership framework that described the knowledge, skills, strategies, and tools leaders needed to positively impact student achievement. In addition, Waters et al. (2003) developed a knowledge taxonomy tool that organized leadership knowledge into four types: (a) experiential knowledge, (b) declarative knowledge, (c) procedural knowledge, and (d) contextual knowledge.

It is important to note that findings from both meta-analyses shared several themes. School leadership responsibilities and behaviors emphasized shaping the school culture, maintaining relationships with teachers and students, and serving as instructional leaders. Of particular importance is that both meta-analyses included direct involvement of the principal in matters of design and implementation of curriculum, instruction, and assessment practices. They also recommended that effective principals provided teachers with materials and professional development necessary for successful execution of their jobs. Both studies linked principal behaviors identified in previous principal models such as instructional, transformational and shared leadership. Concomitantly, other researchers also sought to determine relationships between all principal models and further contribute to and define the knowledge base.

One such noteworthy mixed methods study was conducted by Marks and Printy (2003). They examined the potential of active collaboration among principals and teachers regarding instructional matters to enhance the quality of teaching and student performance. Within this shared leadership model, principals and teachers shared responsibility for improving instructional tasks, assessments, and curriculum development. Teachers provided their expertise to principals in school improvement. The principal was envisioned as the “leader of instructional leaders” versus the sole instructional leader (Glickman, 1989, p. 6). The analysis of this study was grounded in a comparison of the conceptions of transformational and instructional leadership models. Transformational leadership emphasized principals motivating teachers by developing a shared vision for the school, maintaining high expectations, and modeling organizational values (Leithwood, 1994, 1995; Leithwood & Jantzi, 1990; Leithwood, Jantzi, &

Steinbach, 1999). Instructional leadership envisioned principals as the sole authority to maintain high expectations for students and teachers, independently supervise instruction and student progress, and coordinate the school's curriculum (Barth, 1986; Marks & Printy, 2003). The authors hypothesized that while transformational leadership was necessary for school improvement, it was insufficient to achieve high quality teaching and learning. Consequently, they examined shared instructional leadership to the pedagogical practice of teachers and student performance.

The sample consisted of 24 nationally selected schools that participated in a School Restructuring Study conducted by the Center on Organization and Restructuring of Schools. There were eight schools from each school level: elementary, middle, and high school. The data set included: (a) teacher surveys that inquired about instructional and professional practices and perceptions of their school and its organization, (b) interviews and observations with 25-30 staff members and administrators from each school, (c) evaluation of instruction and assessment practices of 144 core-teachers (72 mathematics and 72 social studies) on standards of intellectual quality, and (d) over 5000 student assignments on assessment tasks were collected and rated according to standards of authentic achievement. The dependent measures used in the study were pedagogical quality, assessment task, and academic achievement. Independent measures were leadership and school demographics.

The instruction and assessment practices of teachers were evaluated and rated by two trained researchers according to standards of intellectual quality. The joint observations interrater reliability was .78. The evaluation of written assessment tasks was based on each teacher's two written assessment tasks that represented their typical

assessed learning. Subject matter specialists and trained teacher practitioners rated the assessment tasks on standards of intellectual quality. A consensus score was agreed upon after individual rating and mutual discussions. Over 5000 student assignments were also retrieved from teachers and rated by teams of two raters according to standards of authentic achievement. The interrater reliabilities were .77 for social studies and .70 for mathematics.

Pedagogical quality comprised of classroom instruction and assessment tasks. Classroom instruction scores resulted from classroom observations on four standards of authenticity: (a) higher order thinking (students manipulate information and ideas versus merely reproducing them), (b) substantive conversations with teacher and peers, (c) depth of knowledge that reflects conceptual understanding, and (d) connections to the world beyond the classroom. The measure of classroom instruction was standardized ($M=0$, $SD=1$). Its reliability (internal consistency) by Cronbach's α was .85. The assessment task scores were the summed ratings on seven standards of authentic assessment: (a) organization of information (students organize, synthesize, interpret, explain, evaluate complex information), (b) consideration of alternative solutions, strategies, or perspectives, (c) demonstrate understanding of disciplinary content, (d) demonstrate methodological approach of discipline, (e) elaborated written communication, (f) extend the problem to real world, and (g) present to an audience beyond school. The measure of assessment tasks was standardized ($M=0$, $SD=1$, Cronbach $\alpha = .79$). The pedagogical quality composite measure was also standardized ($M=0$, $SD=1$, Cronbach $\alpha = .79$). Student academic achievement was based on authentic performance on the sum of student scores in mathematics and social studies on three standards of intellectual quality:

(a) analysis, (b) disciplinary concepts, and (e) elaborated written communication. The measure of academic achievement was also standardized ($M=0$, $SD=1$, Cronbach $\alpha = .72$).

Marks and Printy (2003) examined the relationship between shared instructional leadership and transformational leadership by using scatterplot analysis. Results indicated that transformational leadership was a necessary condition for shared instructional leadership. They also used one-way analysis of variance (ANOVA) to determine how schools with varying leadership approaches differed according to their demographics, organization, and performance. Distinct group differences were seen on school performance measures. Low leadership schools averaged -0.67 SD on pedagogical quality, compared with the limited leadership schools scoring at the mean and integrated leadership schools scoring at 0.86 SD ($p \leq .01$). Similarly, authentic achievement scores in the low leadership schools averaged -0.83 SD; in the limited leadership schools, 0.21 SD; and in the integrated leadership school, 0.85 SD ($p \leq .001$). Comparison for school groups by type of leadership revealed notable patterned differences. Low leadership tended to be present in smaller schools where students were poor, minority, and lower achieving. Integrated leadership was found in larger schools with low proportions of poor, minority, and lower achieving students. Limited leadership schools were in between the above two types in terms of leadership and student characteristics. The findings also indicated that schools with integrated leadership had higher pedagogical quality (0.6 SD, $p \leq .05$) and were higher achieving (0.6 SD, $p \leq .01$) compared with other schools.

Consequently, integrated leadership that incorporated instructional and transformational leadership styles was seen as most beneficial. This new type of leadership, shared instructional leadership, encouraged teachers to take on an

instructional leader role for improving school performance. The interactive nature of shared instructional leadership promoted a positive culture in the school and developed capacity where teachers and principals worked collaboratively towards common goals for teaching and learning. Considerable enthusiasm emerged regarding shared instructional leadership due to its interdependent nature to capitalize on the strengths and abilities of many (Leithwood & Mascall, 2008). However, some questioned its effectiveness and perceived it as a possible hindrance to having clarity of purpose (Leithwood & Jantzi, 2000).

In order to find empirical evidence to justify the positive effects of shared instructional leadership, Leithwood and Mascall (2008) conducted a study that aimed to estimate the impact of collective (also referred to as shared, distributed or integrated) leadership on key teacher variables and on student learning. The survey data were from a previous larger study, *Learning From Leadership*, conducted by Leithwood, Louis, Anderson, and Wahlstrom (2004). Stratified random sampling procedures were used to select 180 schools within 45 districts within nine states to ensure variation in size, student diversity, trends in student performance on state accountability measures, school level, evidence of success in improving student achievement throughout three years or more, geography, demographics, state governance for education, curriculum standards, leadership policies, and accountability systems.

The data consisted of 2,570 teacher surveys of which 49 out of 104 items were used for this study. The survey items measured perceptions of collective leadership and antecedent variables to teacher performance such as capacity, motivation, work settings and conditions. Student achievement data, collected from state websites, included school

wide results on state mandated tests of language and mathematics at several grade levels over a period of three years. Scores were represented by the percentages of students meeting or exceeding the proficiency level of language and mathematics tests. In order to have a single achievement score, the researchers averaged the percentages across grades and subjects. Individual responses from the survey were merged with school level achievement results to calculate means, standard deviations, and reliabilities (Cronbach's α) for scales measuring the variables. Hierarchical multiple regression was used to examine the moderating effects of student socioeconomic status and path analysis tested the validity of causal inferences.

Results indicated that all scales used to measure antecedent variables to teacher performance and collective leadership achieved acceptable levels of reliability of between .72 and .96. Correlations among all variables in the study revealed significant relationships among collective leadership and teacher variables. For example, correlations among collective leadership and teacher's work setting was $r = .58$ and collective leadership and teacher motivation was $r = .55$. Other significant relationships to student achievement were teacher's work setting ($r = .37$), teacher motivation ($r = .36$), and collective leadership ($r = .34$). The researchers used LISREL software calculations to test relationships among collective leadership, teacher capacity, motivation, and work setting, and student achievement.

Results also indicated an excellent fit of the model to the data (root mean square error of approximation = .00; root mean square residual = .03; adjusted goodness of fit index = .93; norm fit index = .99) and as a whole accounts for 20% of the variation in student achievement. Collective leadership accounted for only 13% of the explained

variation in teacher capacity. Hierarchical regressions indicated that only teacher motivation explained the variation in student achievement when controlling for student SES ($r = .29$). Overall, collective leadership had modest but significant indirect effects on student achievement, the influence of collective leadership on students was seen through its influence on teacher motivation.

At the conclusion of their study, Leithwood and Mascall (2008) noted that as of yet, there was “no empirical justification for advocating more plural distribution of leadership as a strategy for organizational improvement beyond those important to enlist the full range of capacities and commitments found within school organization” (p. 557). They recommended future studies to assess the effects of different patterns of collective leadership using powerful mediating variables that would be susceptible to influence by leaders and have significant effects on students.

Amidst these findings, some scholars argue that the entire field of research on educational leadership needs to be scrutinized to establish a knowledge base that addresses fundamental questions (Levin, 2005). Others have noted that the “big tent” strategy has prevailed and may be responsible for the increased diversity of questions asked by researchers in recent years which has resulted in researchers, policy-makers, and practitioners talking past each other (Hallinger & Heck, 2005). A similar debate also exists regarding the standards for school leadership.

Professional Standards for School Leadership

Amidst the challenges in defining the role of school leadership, the Interstate School Leaders Licensure Consortium *Standards for School Leaders* are surrounded by controversy (English, 2006; Murphy, 2005; Young, Petersen, & Short, 2002). The history

behind their development is presented to explain their conception and role in the current landscape of school administration. As the age of accountability in education started with the publication of *A Nation at Risk* (1983), accountability for student achievement also progressed from teachers and students to principals (Grogan & Andrews, 2002).

Consequently, in this changing environment, leadership standards were needed to guide principals and provide a measure for their performance. A report of the National Commission on Excellence in Educational Administration, *Leaders for America's Schools*, reinforced the need to improve the quality of educational leadership (Murphy & Shipman, 1999).

Therefore, in mid-1990 the National Policy Board for Educational Administration (NPBEA) established the Interstate School Leaders Licensure Consortium (ISLLC). In 1996, the ISLLC brought together groups with a stake in educational leadership such as states, universities, professional organizations and the National Alliance of Business to develop and publish a standards framework for education leaders (CCSSO, 2008; Murphy, 2005; Murphy & Shipman, 1999). Their objective for designing leadership standards was to reshape the profession by aligning the theoretical and practical knowledge base of existing and future school leaders in preparation programs (Iwanicki, 1999; Murphy, 2005; Murphy & Shipman, 1999).

Amidst the backdrop of two epistemologies present in educational leadership, practice-based knowledge and espoused theories (Donmoyer, 1999), the ISLLC sought to reground the profession by using empirical findings from effective school studies in the development of standards (Murphy, 2005). Murphy (2005) states that the Standards for School Leaders “provide the means to shift the metric of school administration from

management to educational leadership and from administration to learning while linking management and behavioral science knowledge to the larger goal of student learning” (p. 166). However, upon the arrival of the ISLLC Standards, there was little consensus as critics continued to contend that they lacked empirical evidence (English, 2006; Hess, 2003) and were conceptually superficial (Hess, 2003; Marshall & McCarthy, 2002). Furthermore, they were also implemented differently among users due to confusion in understanding the difference between the policy, practice and/or program standards (CCSSO, 2008).

However, despite the controversy, the 1996 ISLLC Standards survived in the field of educational leadership and remain the only common set of standards developed by a national body of stakeholders designed for school leaders. Furthermore, they also serve as a template for other national leadership organization standards. For example, the National Association of Elementary School Principals (NAESP), the National Association of Secondary School Principals (NASSP), and the American Association of School Administrators (AASA) built their standards on the foundation of the 1996 ISLLC standards. However, in order to meet the demands of the 21st century within the changing policy context of American education and in response to requests from stakeholders and critics in educational leadership, the 1996 ISLLC Standards were revised in 2008 and published as the *Educational Leadership Policy Standards* (CCSSO, 2008).

The revised standards were specifically “designed to be discussed at the policymaking level to set policy and vision” (CCSSO, 2008, p. 6). While the language of the 1996 and 2008 ISLLC six broad standards is similar (see Table 1), specific leadership indicators were not listed in the revised edition, as they were deemed too restrictive

(CCSSO, 2008). The revised standards were intended to provide overall guidance and vision by replacing the previous knowledge, skills, and dispositions with function. The role of principals as instructional leaders and “the importance of sound education leadership at all levels to raising student achievement” (CCSSO, 2008, p. 17) are emphasized.

Table 1.
Comparisons Between ISLLC 1996 and 2008 Standards

ISLLC Standards for School Leaders: 1996	Educational Leadership Policy Standards: ISLLC 2008 (Changes are underlined)
<p>STANDARD 1: A school administrator is an educational leader who promotes the success of all students by facilitating the development, articulation, implementation, and stewardship of a vision of learning that is shared and supported by the school community.</p> <p>Knowledge, Skills & Dispositions: 29</p>	<p>STANDARD 1: <u>An education leader promotes the success of every student</u> by facilitating the development, articulation, implementation, and stewardship of a vision of learning that is shared and supported by <u>all stakeholders</u>.</p> <p>Functions: 5</p>
<p>STANDARD 2: A school administrator is an educational leader who promotes the success of all students by advocating, nurturing, and sustaining a school culture and instructional program conducive to student learning and staff professional growth.</p> <p>Knowledge, Skills & Dispositions: 39</p>	<p>STANDARD 2: <u>An education leader</u> promotes the success of <u>every student</u> by advocating, nurturing, and sustaining a school culture and instructional program conducive to student learning and staff professional growth.</p> <p>Functions: 9</p>
<p>STANDARD 3: A school administrator is an educational leader who promotes the success of all students by ensuring management of the organization, operations, and resources for a safe, efficient, and effective learning environment.</p> <p>Knowledge, Skills & Dispositions: 38</p>	<p>STANDARD 3: <u>An education leader</u> promotes the success of <u>every student</u> by ensuring management of the organization, operations, and resources for a safe, efficient, and effective learning environment.</p> <p>Functions: 5</p>
<p>STANDARD 4: A school administrator is an educational leader who promotes the success of all students by collaborating with families and community members, responding to diverse community interests and needs, and mobilizing community resources.</p> <p>Knowledge, Skills & Dispositions: 29</p>	<p>STANDARD 4: <u>An education leader</u> promotes the success of <u>every student</u> by collaborating with <u>faculty</u> and community members, responding to diverse community interests and needs, and mobilizing community resources.</p> <p>Functions: 4</p>
<p>STANDARD 5: A school administrator is an educational leader who promotes the success of all students by acting with integrity, fairness, and in an ethical manner.</p> <p>Knowledge, Skills & Dispositions: 29</p>	<p>STANDARD 5: <u>An education leader</u> promotes the success of <u>every student</u> by acting with integrity, fairness, and in an ethical manner.</p> <p>Functions: 5</p>
<p>STANDARD 6: A school administrator is an educational leader who promotes the success of all students by understanding, responding to, and influencing the larger political, social, economic, legal, and cultural context.</p> <p>Knowledge, Skills & Dispositions: 19</p>	<p>STANDARD 6: <u>An education leader</u> promotes the success of <u>every student</u> by understanding, responding to, and influencing the ** political, social, economic, legal, and cultural context.</p> <p>Functions: 3</p>

Note. From "Appendix 1: Comparing ISLLC 1996 and ISLLC 2008," by the National Policy Board for Educational Administration, p. 18. Copyright 2008 by the Council of Chief State School Officers.

Other national organizations committed to improving student achievement by strengthening educational leadership include the Institute for Educational Leadership (IEL). IEL is a non-profit organization based in Washington, DC focused on increasing student achievement and preparing students to meet the challenges of the 21st century. IEL has identified three key roles (instructional, community, and visionary leadership) that principals of the 21st century should fulfill. Once again, instructional leadership is seen as a crucial component in strengthening four key areas: teaching and learning, professional development, data-driven decision making, and accountability. Community and visionary leadership advocate for school's role in society to demonstrate a commitment that all children will achieve high levels of success (Institute for Educational Leadership, 2000). A report sponsored by IEL, *Preparing School Principals: A National Perspective on Policy and Program Innovations*, discusses the challenges and recommendations of preparing a new generation of school leaders to be instructional leaders who can effectively implement standards-based reform (Hale & Moorman, 2003). It highlights the need for educational leaders to have complete understanding of effective instructional practices as they are leading professional development practices and required to demonstrate improved student achievement.

Elementary Science Education

Importance of Elementary Science Teaching

The importance of elementary science teaching has never been greater (Lee & Houseal, 2003). National science education reform documents advocate the teaching of science beginning in the earliest elementary grades (American Association for the Advancement of Science, 1989, 1993; National Research Council, 1996, 2002).

Elementary students need access to good science instruction as early as possible as it helps them develop scientific habits of mind and skills necessary for engaging in scientific inquiry (Schwartz, Lederman, & Abd- El-Khalick, 2000). This places a greater emphasis on elementary science teaching than our society allows (Mulholland & Wallace, 2005). The early school years are critical in the development of positive attitudes towards science (National Research Council, 1996, 2002; Victor & Kellough, 2000) as they have the ability to spark students' interest, curiosity, and imagination for the field (Marx & Harris, 2006). Early exposure to science also promotes interest in the Science, Technology, Engineering, and Mathematics (STEM) fields. It facilitates understanding of how scientists work and the tentative nature of science (Rhoton, 2001). These years lay the foundation for sophisticated understandings in science and encourage children to observe and question their natural surroundings to make sense of their world (Harlen, 2000; Mullholland & Wallace, 2005).

Many scholars have continued to assert the benefits of elementary science teaching. Some advantages include that it facilitates the development of communication skills (Harlen, 2000), provides an experiential, conceptual, and attitudinal foundation for future science inquiry (Plevyak, 2007), and promotes the development of collaboration skills (Baines, Blatchford, & Chowne, 2007). It also ensures homegrown scientists in our nation and thus economic competitiveness (Marx & Harris, 2006). In addition to the benefits of keeping pace with economic competitors, science enhances the capability of students to think creatively, make decisions, solve problems, engage intelligently in public discourse, become independent thinkers, and debate about important issues regarding science, technology and natural resources (National Research Council, 1996).

Improved science teaching has also resulted in higher performance on tests in other disciplines (Lara-Alecio et al., 2012). For example, a preliminary study funded by the U.S. Department of Education compared Alabama Math, Science, and Technology Initiative (AMSTI) schools with control groups from non-AMSTI schools (State of Alabama Department of Education, 2012). AMSTI is a professional development delivery system for STEM education in Alabama and its initiative to improve K-12 math and science teaching statewide. Approximately 30,000 students and 780 teachers in 82 schools participated in a randomized controlled trial spanning five years to determine the effectiveness of AMSTI schools.

Researchers gathered data in the form of classroom observations, interviews with teachers and principals, professional training logs, professional development surveys, online surveys, student achievement data from multiple sources and demographic data. Students in AMSTI schools scored statistically higher than students in non-AMSTI schools on standardized tests in mathematics, reading, and science in grades 3 to 5. The positive effects were cumulative, resulting in improvement in performance between 2.25 and 4.19 percentile rank points for each consecutive year students were in the AMSTI science program (State of Alabama Department of Education, 2012).

Reformed View of Science Education

The current reform movement in science education can be traced back to 1985 with Project 2061, which was founded by the American Association for the Advancement of Science. The aim of Project 2061 was to help all Americans become literate in science, mathematics, and technology. In 1989, their landmark publication, *Project 2061: Science for All Americans* (American Association for the Advancement of Science, 1989),

recommended what all students should know and be able to do in science, mathematics and technology by the time they graduate from high school. These recommendations were further translated into learning goals or benchmarks for grades K-12 in the publication *Benchmarks for Science Literacy* (American Association for the Advancement of Science, 1993). These two publications established the foundation for the science standards movement of the 1990's that led to the development of the *National Science Education Standards* by the National Research Council of the National Academy of Sciences (National Research Council, 1996). Among the current science reform documents that have been published (local, state, national), all have been written using the content from these publications.

Philosophically, the contemporary reform movement in science education is based on one of the most influential theories in education known as constructivism (Driver, Asoko, Leach, Mortimer, & Scott, 1994; von Glaserfeld, 1989). The essence of constructivism is “that knowledge is not transmitted directly from one knower to another, but is actively built up by the learner” (Driver et al., 1994, p. 5). Specifically for learning science, constructivism is seen as a social process that serves as a catalyst for cognitive development (Fowler, 1994). The *National Science Education Standards* emphasize, “learning science is something students do, not something that is done to them. In learning science, students describe objects and events, ask questions, acquire knowledge, construct explanations of natural phenomena, test those explanations in many different ways, and communicate their ideas to others” (National Research Council, 1996, p. 2). There is an emphasis on student-centered investigations to engage learners and build upon their prior knowledge. The teacher acts as a facilitator and promotes a collaborative

environment in the classroom where multiple ideas are encouraged and valued.

Additionally, the curriculum is viewed as being flexible and focuses on depth to promote conceptual understanding.

The reformed perspective of teaching and learning science is in complete opposition to the traditional view. The traditional stance envisions learners as blank slates that accumulate information through teacher-centered instruction. Learners are encouraged to work independently with a heavy reliance on textbooks and learn by rote memorization. There is also a heavy reliance on the teacher as the main dispenser of knowledge where basic skills are emphasized. Furthermore, the curriculum is viewed as a fixed entity that lacks depth.

Inquiry Science Instruction and Student Outcomes

Organizations such as the American Association for the Advancement of Science (AAAS), the National Research Council (NRC), and the National Science Foundation (NSF) have invested millions of dollars to support the use of inquiry science teaching as a means to improve student understanding of scientific concepts (Minner, Levy, & Century, 2010). The recommendations outlined in the *National Science Education Standards* also reflect a commitment to inquiry-based instructional practices. In an era of sanctions, scholars continue to determine the effectiveness of inquiry instruction on student outcomes.

Several noteworthy studies examining the effects of inquiry instruction on student outcomes have been conducted. For example, a large-scale study examined the effects of a multifaceted scaling reform project that focused on standards based science teaching in urban middle schools (Geier, et al., 2008). Participants included 37 teachers in 18 schools

involving approximately 5000 7th and 8th grade students. Two cohorts of 7th and 8th graders were compared with the remainder of the same district population, using results from the Michigan Educational Assessment Program (MEAP) high stakes state standardized science test. A partnership effort between the University of Michigan and Detroit Public Schools sought to determine whether urban student participation in project based inquiry science curricula would lead to demonstrably higher student achievement on MEAP over and above general district wide reform efforts.

The partnership provided summer workshops, technology resources in the classroom and developed teacher mentors and learning communities. The project based inquiry science units were developed by the Center for Learning Technologies in Urban Schools (LeTUS) at the University of Michigan and supported by aligned professional development and learning technologies to prepare teachers to implement the curriculum consistent with its intent. Professional development was continuously revised to reflect the needs of the teachers and student performance.

The method of analysis compared students who participated in the LeTUS curricula to students in the public school system who did not. Participating in at least one LeTUS unit was associated with a 19% increase in passing rate in Cohort I and a 14% increase for Cohort II. The differences were statistically reliable (Chi Square 117.8 and 103.1, respectively; $df=9660, 9704$; $p < .001$). In Cohort II, higher MEAP scores were associated with both 7th and 8th grade participation independently ($F=91.7, 17.5, df=9705$, $p < 0.001$; interaction $F=0.15$). Participation in the 7th grade units was associated with a 37 point greater raw MEAP score compared with non-participating peers and participation in one 8th grade unit indicated a 23 point MEAP score difference. However,

in Cohort I, a MEAP score difference was seen with only the 8th grade ($F=186$, $df=9669$, $p < 0.001$). MEAP scores for the 7th grade participants slightly declined when compared with their non-participating peers ($t=1.74$, $df=9219$, $p < 0.1$).

Participation in at least one LeTUS unit also indicated a reduction in the gender gap in science achievement in both cohorts. It was marginal for Cohort I ($F=1.90$, $df=9546$, $p < 0.17$) and statistically reliable for Cohort II ($F=4.59$, $df=9633$, $p < 0.05$). These findings suggest that standards-based instruction incorporating technology not only reduced the gender gap in science achievement but also improved standardized achievement test scores.

In another study of grades 3-5, learning gains were demonstrated when inquiry-based instruction was implemented. Using qualitative methodology, Lee, Buxton, Lewis, and LeRoy (2006) examined elementary students' ability to conduct inquiry through their participation in a yearlong intervention based on the definition of science inquiry in the *National Science Education Standards* (National Research Council, 1996, 2002). Science inquiry units were designed to promote students to generate questions, plan procedures, design and carry out investigations, analyze data, draw conclusions, and report findings. Participants included 25 third and fourth grade students, seven teachers from six urban elementary schools representing diverse linguistic and cultural groups. Participating teachers were asked to select students of different achievement levels from their classes to be a part of the study.

The teachers attended four full-day workshops on how to implement the instructional units in their classrooms. The first workshop focused on promoting inquiry-based science instruction, the second focused on how to incorporate English language

and literacy in science instruction, the third focused on the role of students' home languages and cultures in science instruction, and the fourth focused on teacher feedback on the instructional units. One-on-one 20-40 minute audio and videotaped elicitation sessions were conducted with the students at the start and end of the school year by one of the five research team members. The students conducted a semi-structured inquiry task on evaporation during the elicitation. Transcripts were initially coded using coding categories based on existing literature on student science inquiry (theoretical categories). The second set of coding comprised of conceptual categories based on emerging themes from the preliminary data analysis.

Results indicated learning gains in inquiry abilities in students from all demographic subgroups. Furthermore, students from non-mainstream and less privileged backgrounds in science showed greater gains in inquiry abilities than their more privileged counterparts. This study suggests that inquiry-based instructional units had a positive impact on the development of science inquiry abilities.

Chang and Barufaldi (1999) also examined the effects of an inquiry problem-solving-based instructional model on student achievement. Their study included 172 ninth grade students in four Earth Science classes and employed a pre-test/post-test control group design of items from a Taiwan entrance examination for senior high school. The pre-test and post-test items were classified into categories of knowledge and application questions. During a six-week period, two classes (N=86) were randomly assigned as the treatment group and were taught using modified instructional approaches such as student brainstorming and identifying problems, group discussions to prepare and implement their plans with an occasional student-designed activity, and class presentation

of their learning. Another two classes (N=86) were randomly assigned to be the control group and received traditional instruction. Traditional instruction comprised of teacher-centered direct lectures, explanations and occasional demonstrations by the instructor. The teacher was the main source of information for the students.

Results revealed that the problem-solving-based instructional approach produced significantly greater student achievement ($p < .05$) than the traditional approach, especially at the application level ($p < .05$). A chi-square analysis on student alternative frameworks measure revealed that students who were taught using the problem-solving-based approach experienced significant conceptual changes than did students who were taught using the traditional lecture type approach ($p < .001$).

The findings from the above studies highlight the positive impact of inquiry-based instruction on student science outcomes. Students are able to understand the conceptual concepts and gain better understanding of science. These studies also demonstrate that inquiry science instruction has the potential to reduce the gender gap in science achievement and increase gains in inquiry abilities of all demographic subgroups.

Current State of Elementary Science Teaching

Despite the overwhelming advantages of having early access to science education, diminished instructional time and resources are being devoted to it (Marx & Harris, 2006). The National Institute of Child Health and Human development (2005) conducted a large study of third grade classrooms and found that a predominant amount of instructional time is devoted to literacy (56%) and mathematics (29%), while minimal time is allotted to science (6%). It is important to note that accountability policies are

only partly to blame in the considerable emphasis placed on literacy and mathematics instruction (Johnson, Kahle, & Fargo, 2006).

While accountability policies have influenced the amount of time spent on science instruction in elementary schools, there are other constraints as well. Elementary school teachers, considered generalists rather than specialists, avoid teaching science (Appleton, 2008; Sanders, Borko, & Lockard, 1993; van Driel, Verloop, & de vos, 1998). This has been an ongoing issue for several decades and the situation has not changed significantly (Appleton, 2008; Harlen & Holroyd, 1997; Lee & Houseal, 2003; Tilgner, 1990).

Furthermore, among all the sciences, physical science teaching appears to be of greatest concern in elementary schools. McDermott (1989) notes that elementary teachers are particularly insufficiently prepared in physical science and, as a result, lack enthusiasm and confidence teaching it. This in turn transmits to students a dislike of physical science. Researchers have found that elementary students perceive their physical science competence lower than their reading or math competence, expect lower grades in physical science, and attach lower importance to physical science than to reading (Andre, Whigham, Hendrickson, & Chambers, 1999).

Lee and Houseal (2003) note that constraints to teaching elementary science are not limited to the above. They have identified constraints to teaching elementary science into external and internal factors. The external factors include money, supplies, materials, equipment, classroom management, dealing with diverse learners and individual differences, support from colleagues, administrators and the community. The internal factors include teacher content preparation, self-confidence levels, attitudes, and professional identity towards teaching science. Many of these constraints contribute to

elementary teacher's hesitancy to teach science (Appleton, 2008). Furthermore, their low self-efficacy and lack of self confidence tends to arise from their limited science subject matter knowledge (Appleton & Kindt, 1997). Harlen (1997) has identified six avoidance strategies used by primary teachers to teach science:

1. Avoidance: teaching as little of the subject as possible,
2. Keeping to topics where confidence is greater - usually meaning more biology than physical science.
3. Stressing process outcomes rather than conceptual development outcomes,
4. Relying on the book, or prescriptive work cards which give pupils step by step instructions,
5. Emphasizing expository teaching and underplaying questioning and discussion,
6. Avoiding all but the simplest practical work and any equipment that can go wrong (p. 335).

These avoidance strategies are consistent with teachers' naive views about scientific work and roles of theories and evidence (Abell & Smith, 1994). Many future elementary teachers associate alienation and fear with their own science learning (Smith & Anderson, 1999) since they did not develop clear understanding of the science content covered in their own K-16 education (Harlen, 1997). Within this context, teachers require support from elementary school principals as principals are considered a critical determinant in the success of efforts to improve instruction (Leithwood & Montgomery, 1982). Intervention by principals is necessary to improve teacher knowledge, skills and

access to resources (Leithwood, 1981; National Association of Elementary & Secondary Principals, 2008).

Theoretical Framework

Instructional Leadership Theory

Instructional leadership theory places principals at the center of leadership functions related to teaching and learning (Murphy, 1990). The instructional leadership role is complex and dependent on personal, contextual, and organizational factors (Hallinger & McCary, 1990). Effective instructional leaders use a wide array of approaches that integrate reflection and growth to build a culture of improvement (Blase & Blase, 1999). They value teacher input about instruction and understand that improving schools is a journey of learning and risk taking (Fullan & Miles, 1992).

In addition to performing the traditional managerial tasks, instructional leaders are responsible for guiding teacher instruction, overseeing teacher implementation of the curriculum, providing teachers with relevant professional development opportunities and instructional resources, facilitating instructional collaboration among them, and being knowledgeable about subject matter and teaching strategies (Barth, 1990; Crow, Hausman, & Scribner, 2002; Stein & Nelson, 2003). Instructional leaders recognize the conditions that need to be developed in their schools so that teachers can facilitate student learning (Elmore, 1979). They allocate time and multiple opportunities to enable teachers to gain a deep understanding of the key ideas in a curriculum (Robinson, 2006).

Leadership Content Knowledge

With a growing emphasis on leadership of teaching and learning and the relationship between leadership and student outcomes (Elmore, 2004; Firestone & Riehl,

2005; Robinson, 2006), Stein and Nelson (2003) propose a leadership content knowledge construct for administrators that draws attention to the importance of subject matter knowledge in instructional leadership. With three cases, Stein and Nelson (2003) provided evidence of how principal leadership was transformed as they gained understanding of subject matter knowledge. Other researchers suggest that principals with subject matter knowledge can facilitate teachers' acquisition and application of content-specific pedagogical knowledge during classroom observations (Burch & Spillane, 2003; Stein & D'Amico, 2002).

Stein and Nelson's (2003) leadership content knowledge construct draws a parallel from Shulman's (1986) pedagogical content knowledge which claims that teachers need a unique type of knowledge that addresses the interaction of their subject matter knowledge and general pedagogical knowledge. Pedagogical content knowledge is a dimension of subject matter knowledge specifically and exclusively reserved for teaching. However, it is contingent upon transformation of knowledge from other domains, especially content knowledge.

Similarly, Stein and Nelson (2003) argue that administrators need a degree of understanding of the various subjects taught in their schools "to set the conditions for continuous academic learning among their professional staff" (p. 424). Leadership content knowledge represents a type of subject matter knowledge that facilitates strong instructional leadership. It provides principals with knowledge and skills to make informed decisions that lead teachers towards good practice. It represents the interaction of subject matter knowledge and the practices that define leadership specifically with the improvement of teaching and learning.

Leadership content knowledge is related to knowledge about how to lead. It facilitates how instructional leaders: (a) promote and maintain a school culture, (b) use and provide professional development programs, (c) use and provide resources, (d) conduct a curriculum selection process, and (e) make decisions that foster successful academic reforms. Stein and Nelson (2003) note that in order for principals to assist teachers to improve their instruction, their understanding will need to encompass subject matter knowledge, how to teach the subject matter, how students learn the subject matter, and effective ways of teaching teachers.

Stein and Nelson (2003) take a socially interactive, constructivist orientation toward teaching and learning. Constructivist views assume that individuals acquire knowledge by building it from natural capabilities interacting with the environment. Accordingly, Stein and Nelson (2003) envision the role of principals beyond transmitting knowledge to their teachers, but rather being responsible for: (a) understanding the learning needs of individuals, (b) arranging the interactive social environments that embody the right mix of expertise and appropriate tasks to spur learning, (c) putting the right mix of incentives and sanctions into the environment to motivate individuals to learn, and (d) ensuring that there are adequate resources available to support the learning. Similar to pedagogical content knowledge, leadership content knowledge embodies multi-faceted thinking and reasoning, but remains “anchored in knowledge of the subject and how students learn” (Stein & Nelson, 2003, p. 442).

Furthermore, Stein and Nelson (2003) recommend that the characterization of subject matter knowledge for instructional leaders is different by function. Gaining an understanding of one subject matter will facilitate the development of knowledge of

additional subject matters by “postholing”. Specifically, they suggest that principal “knowledge in one subject will prepare them to conduct highly focused explorations of other subjects in very productive ways” (p. 443). For example, in their case study exploring the knowledge administrators needed to improve teaching and learning in the classroom, they found that district leader decisions were based on the similarities in the knowledge about how students learned in mathematics and literacy. However, they were unclear about the extent to which the leaders recognized strategic differences between teaching and learning in these two subjects.

Implications for Principals

Improving science education is envisioned as part of a systemic effort that includes, among others, students, teachers, teacher education programs, and principals (National Research Council, 1996, 2011). More than ever before, principals’ roles center on enhancing teaching, learning, and creating powerful learning environments versus the traditional focus on managerial and administrative tasks (Kaplan et al., 2005). Sunderman, Orfield and Kim (2006a, 2006b) note that principals will not only need to evaluate the effectiveness of curriculum programs in their school but will also need to ensure that testing activities do not consume time for basic teaching and learning. Therefore, if principals can recognize good instruction and support teachers in teaching science that is consistent with the philosophy that underlies the science education reform movement, such as constructivism, they can provide a foundation for the learning of science. Principals can help teachers develop and implement effective pedagogy in the classroom by selecting professional development opportunities that align to best practices in science education (Stein & Nelson, 2003).

Policy initiatives and reform movements continue to place considerable emphasis on the role of principals and compel them to use their influence and authority to help shape and support school science reform. In light of the external and internal factors identified as constraints to elementary science teaching (Lee & Houseal, 2003), principals will be required to demonstrate leadership in science to alleviate some of the barriers. They will be compelled to discuss science teaching with their teachers, visit classrooms during science instruction, identify community resources that can enhance science instruction, help conduct inventories of equipment and supplies, become familiar with local, state, and national science education standards, and make informed decisions in the selection of new science curriculum (Mechling & Oliver, 1983). Rhoton (2001) has outlined systemic approaches that support school science reform and the implications they have for principals:

1. *Create an instructional organization and climate* that are conducive to school-based initiatives and innovations.
2. *Create a clear vision* of effective science teaching, and goals that reflect content knowledge.
3. *Provide high-quality instructional materials* that support a coherent presentation of important science concepts.
4. *Provide the necessary resources* to make materials available to all students.
5. *Support alternative assessment methods* that more accurately measure students' deep understanding of science ideas, not just short term recall.

6. *Support on-going and long-term professional development* of science teachers.
7. *Maintain class size* appropriate for the science discipline.
8. *Hire new science teachers* who are well grounded in science content, the processes of science, and learning theory.
9. *Support environments* in which all students can learn science in some meaningful way.
10. *Communicate to teachers* about research and innovative practices outside the school district.
11. *Allow teachers to visit innovative science programs* both within and outside the school district.
12. *Encourage grant writing* to supplement school resources.
13. *Pair induction teachers* (new science teachers) with compatible mentor teachers in an effort to provide neophytes with role models at the beginning of their teaching careers (p. 14).

Standards driven reform requires change in how principals work (Chance & Anderson, 2003). Successful science reform cannot be accomplished without the instructional leadership role of principals (National Research Council, 1996, 2011). Reform efforts are more likely to be successful when principals provide effective instructional leadership and promote an environment that allows teachers to network and constantly revisit and revise goals (Showers & Joyce, 1996; Sparks & Loucks-Horsley, 1990). In order for principals to implement the role of a science instructional leader

effectively, they will be compelled to capitalize on their science knowledge to inform their decisions.

Therefore, in order to understand the role of principals' subject matter knowledge on student achievement, it is essential to explore their science subject matter knowledge and beliefs about reformed science teaching and learning. Studies indicate that principals who view themselves as instructional leaders encourage collaboration among teachers and individually address instructional issues with them (Carver, 2003; Spillane, Halverson, & Diamond, 2001; Youngs & King, 2002). Furthermore, since principals' actions are informed by a myriad of things such as their professional and personal backgrounds, contextual variables, beliefs about leadership, and responses to district and state policies (Hallinger et al., 1996; Youngs, 2007), it is prudent to conduct research using a framework that incorporates these characteristics.

Conceptual Model

Antecedent with Mediated Effects Model

As research must be envisioned within the historical and social context in which it is designed and conducted (Everhart, 1988), a comprehensive model is needed to determine the effects of leadership on student achievement (Hallinger et al., 1996). Some of the previous models that have been used to study administrator effects have focused on direct effects, moderated effects, and antecedent effects of principal leadership on student learning (Bridges, 1982; Hallinger & Heck, 1996b). With the evolution of school leadership, many of these models have failed to account for prior achievement of students, student socioeconomic status, and effects of intervening variables within the school environment (Hallinger et al., 1996). Consequently, the role of the principal must

be studied within an organizational and environmental context of the school (Hallinger & Heck, 1996b). This approach facilitates understanding of the indirect effects of principal efforts in influencing teachers (Hallinger & Murphy, 1985a, 1985b). It also provides understanding of how principal actions as a leader influence student learning by maintaining a school's instructional climate (Bossert et al., 1982). Positioning principal instructional leadership within an antecedent with mediated effects model is consistent with the current literature on a principal's influence on school effectiveness (Hallinger, 2008; Hallinger et al., 1996; Hallinger & Heck, 1996a, 1996b, 1998). Hallinger et al. (1996) incorporated an antecedent with indirect/mediated-effects framework in a study that explored principals' effects on reading achievement. Their findings supported the use of a conceptual model that includes antecedent and indirect variables and revealed that principal's gender, student's SES, and parental involvement were significant predictors on principal leadership. At the conclusion of the study, Hallinger et al. (1996) recommended using an antecedents and outcomes framework for future instructional leadership studies. They asserted that there was neither a theoretical nor empirical justification for a continuation of direct-effects or antecedent with direct-effects research on the effects of school principals.

Consequently, the conceptual model, shown in Figure 1, guiding this study is based upon recommendations informed by research in instructional leadership. Several background variables have been included in the model of this study for a more accurate depiction of how leadership is shaped by contextual and personal factors. It is important to note that school organizations are dynamic systems where the requirements for leadership change according to the school environment (Hallinger et al., 1996). Education

leaders react and respond to multiple school factors when making decisions (Hallinger & Heck, 1996a, 1996b). Their actions and behaviors are guided by the ideological, social, and political contexts surrounding their schools (Evans, 2007). For example, school characteristics such as student socioeconomic status, ethnic homogeneity, language backgrounds, and type of district may constrain and shape the principal's exercise of instructional leadership (Bossert et al., 1982; Hallinger & Murphy, 1986b; Hallinger & Murphy, 1987b; Heck, 1992; Heck & Marcoulides, 1989).

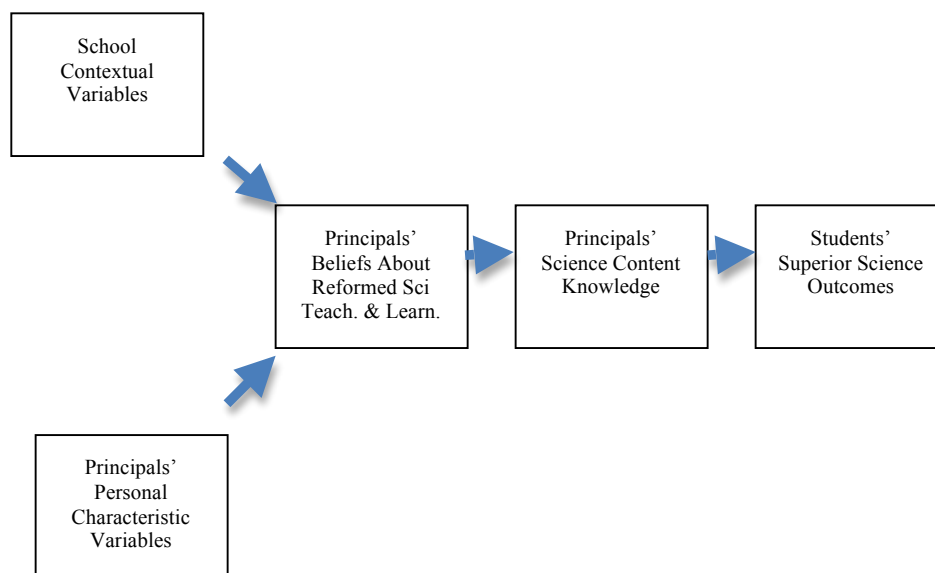

Figure 1. Conceptual Model of Study. Adapted from Pitner (1988).

Amid the contextual factors in schools, principals' personal characteristics are also known to affect their instructional leadership behavior (Boyan, 1988). Principal's gender, ethnicity, years of teaching experience, and years of administrative experience are among some of the factors that influence their leadership behaviors. For example, scholars have noted that female elementary principals are more actively engaged in instructional leadership behaviors than their male counterparts (Glasman, 1984; Hallinger

& Murphy, 1985a; Leithwood, Begley, Cousins, 1990). They tend to view themselves as curriculum and instructional leaders, whereas men view themselves as general managers (Hallinger et al., 1996; Leithwood et al., 1990). Principals' years of teaching and administrative experiences are also important determinants, as they are positively associated with instructional leadership and student outcomes (Clark, Martorell, & Rockoff, 2009; Leithwood et al., 1990). When school leaders understand a subject matter, know how to teach the subject matter, and recognize how students learn the subject matter; they are better able to reach shared understandings with teachers (Printy, 2008). They are also inclined to make informed decisions regarding professional development, curriculum selection, and student learning (Stein & D'Amico, 2002; Stein & Nelson, 2003).

Furthermore, as student outcomes have gained increasing prominence in the accountability movement, researchers have shown that schools perform better when experienced principals lead them. Studies have shown positive relationships between principals' administrative experience at the current school and students' math scores (Clark et al., 2009). Clark et al. (2009) used data from New York City to estimate how the characteristics of school principals relate to school performance, as measured by student standardized math scores while controlling for student background variables. The data on school performance spanned academic years 1998-99 through 2006-07. Student performance was regressed on principal characteristics, student background characteristics, school characteristics, and school fixed effects to account for differences in factors outside of principal control (i.e., comparing principals at the same schools). Results indicated math scores are higher when principals had more experience as either a

teacher, assistant principal at same school where they became principal, and principal experience at current school. Principals with three years of experience were associated with math scores 0.05 standard deviations higher than principals in their first year. However, despite the demand for experienced principals in disadvantaged schools, research reveals that disadvantaged schools continue to have less educated and experienced principals (Robelen, 2009).

In light of all the factors that shape principals, their beliefs about teaching and learning are also integral to their instructional leadership behavior (Barnett & Long, 1986). Although researchers recognize that beliefs influence how principals construct their roles (Barth, 1986; Evans, 2007; Leithwood, Begley, & Cousins, 1992), there continues to be a gap in the education leadership literature regarding cognitive aspects of school administration (Ruff & Shoho, 2005). Copeland (1999) highlights that principal preparation programs lack a focus on revealing tacit assumptions while conveying content through the use of metaphors and heuristics. This may have consequences and affect efforts for successful student achievement (Sarason, 2002; Tye, 2000).

Therefore, in order to address the growing body of literature surrounding the instructional leadership role of principals within an era of accountability and sanctions and the current state of elementary science teaching, principal science content knowledge and beliefs are examined in regard to how they predict student science outcomes.

Summary of Chapter Two

This chapter reviewed literature about the role of school leadership. It began with historical perspectives, then reviewed the emergence of instructional leadership, the original and reformed professional standards for school leaders, the importance of

elementary science education, and the implications for principals within the mandate to improve students' science outcomes. It is important to note that the design of this study was informed by calls for research exploring the intersection of science instructional leadership and science education. As the field of science instructional leadership is in its infancy, the investigation of relationships among principals' science beliefs, knowledge and students' superior science scores will expand our understanding of the influence of instructional leadership on student outcomes. The premise underscoring the conceptual framework of this study is that principals should be knowledgeable about the vision of the national science reform movement and leadership community. It also envisions principals in the strongest position to promote and facilitate the implementation of reformed based science instruction and ultimately influence students' science outcomes.

CHAPTER THREE

Methodology

This chapter describes in detail the research design and methods used in this study. This study was designed to determine if a relationship exists among elementary principals' beliefs about reformed science teaching and learning and science content knowledge on fourth grade students' superior science test scores. Hierarchical multiple regression analysis highlighted how prediction by certain antecedent variables improves on prediction by others.

Although principals are compelled to recognize and understand the tenets of quality instruction (Wahlstrom & Seashore Louis, 2008) and lead the improvement of student achievement (McLeod, D'Amico, & Protheroe, 2003), little is known about the variation in student science outcomes and how they are accounted for by the multiple factors stated in Chapter Two. As a result, this study investigated the correlates of student science outcomes on school contextual and demographic factors, principals' beliefs about science teaching and learning, and principals' science content knowledge. Specifically, the research questions were:

1. Does principals' content knowledge in science and beliefs about reformed science teaching and learning predict students' superior science outcomes above and beyond the effect of background variables such as type of school, student's socioeconomic status and ethnicity, principal's gender, ethnicity, total years of experience as principal, number of years principal in current school, total years experience as teacher, subjects/grades taught, and degrees held?

- a. What is the level of science content knowledge of elementary school principals as determined by the Physical Science Misconceptions Oriented Standards-Based Assessment Resources for Teachers (MOSART) inventory?
 - b. What are principals' beliefs about reformed science teaching and learning as determined by the Beliefs About Reformed Science Teaching and Learning (BARSTL) inventory?
 - c. What are students' superior science outcomes as determined by the percentage of students achieving a performance level four on the New York State Grade 4 Elementary-Level Science Test?
2. Does principals' content knowledge in science mediate the effects of their beliefs about science teaching and learning in predicting students' superior science outcomes above and beyond the effect of background variables such as type of school, student's socioeconomic status and ethnicity, principal's gender, ethnicity, total years of experience as principal, number of years principal in current school, total years experience as teacher, subjects/grades taught, and degrees held?

Methods

Sampling and Participants

The population for this study was limited to K-4, K-5, and K-6 elementary school principals in New York State. Principals of K-3 schools and below were not included since a grade four assessment, New York State Grade 4 Elementary Level Science Test, was used to measure student outcomes for this study. Similarly, principals of grades

seven and beyond were also not included in this study as science should be taught regularly by a designated teacher in a specialized class at these grade levels.

Initially, simple random sampling was used to identify samples of the population from three lists obtained from the New York State Education Department (NYSED) and one list from the New York City Department of Education (NYCDOE). The three lists from the New York State Education Department classified New York State elementary schools as rural, suburban, and urban districts. Each list included the name of the school, grade span, name and email address of the respective principal, and county the school resided in. The urban list obtained from the New York State Education Department did not include schools from the district of New York City because the New York City Department of Education is considered a separate entity from the state. Therefore, a separate list containing information on K-4, K-5, and K-6 elementary school principals was obtained from the city. This list contained the school's name, grade level, and principal's email address. For the purpose of this research, the New York City and New York State urban school lists were combined. Next, three final lists of schools were created from each category (rural, suburban, urban) to proportionately select principals that met the criteria to be included in this study. Once the final lists were created, they included 181 rural schools, 1,113 suburban schools, and 982 urban schools.

In order to give all schools on the lists an equal chance of being selected and reduce sample error, simple random samples of principals from rural, suburban, and urban school districts were drawn independently of each other. As a result, schools from all lists were numbered independently and appeared only once in their respective list. However, due to a low response rate, additional samples from all lists continued to be

selected until the lists were exhausted. Consequently all names on the three lists ended up being selected. As a result, although simple random sampling was initiated in the selection of participants, ultimately all New York State K-4, K-5, and K-6 principals that met the criteria of this research were sampled.

Design

This study was quantitative in nature. Through the use of simple random sampling, elementary school principals from the State of New York were selected to participate in an online survey. The survey (Appendix A) consisted of demographic questions and two survey inventories: K-4 Physical Science MOSART and BARSTL.

Variables

Independent variable(s). The independent variables are described below. Their description and how they were operationalized in the analysis is presented in Table 2.

Type of school (urban, suburban, rural). School district distinctions were categorized by the education department, in the Glossary of Statistics for Public School Districts, using a classification system based on geographical, political, and employment characteristics of counties within New York State (New York State Education Department, 2010a). Urban, suburban, and rural districts were designated as the three categories. Urban districts included Buffalo, Rochester, Syracuse, Yonkers, New York City, and other city districts located within city boundaries. Suburban districts included school districts that were located within standard metropolitan areas but not within cities. The remaining districts that were not located within cities or standard metropolitan areas were designated as rural.

This information was obtained from the New York State Education Department via email correspondence with an Education Program Aide in the Information and Reporting Services Department. A list of New York City schools was also obtained via email correspondence with a coordinator in the Research and Policy Support Group Department. These lists were crosschecked for verification with official school websites.

Students' socioeconomics status. This information was determined by the percentage of students eligible for free or reduced price lunch. This is a common measure used to identify student need based on yearly parental income. It is available online in the Accountability and Overview Report section of the New York State School Report Card (New York State Education Department, 2010b). Income eligibility guidelines for household size are determined annually by the State Education Department to establish a Need/Resource Capacity for districts and consequently students.

Students' ethnicity. This information was retrieved online from the Accountability and Overview Report section in the New York State School Report Cards (New York State Education Department, 2010b). Students were characterized by NYSED within the following ethnicities: American Indian/Alaska Native, Black/African American, Hispanic/Latino, Asian/Native Hawaiian/Other Pacific Islander, White, or Multiracial.

Principals' characteristics: Gender, ethnicity, total years of experience as principal, number of years principal in current school, total years of experience as teacher, subjects/grades taught, degrees held. This information was requested directly from principals on the demographic questionnaire.

Principals' beliefs about reformed science teaching and learning. Principals' beliefs were measured using the BARSTL inventory scores. The BARSTL is discussed in detail under the instrumentation section.

Mediating variable.

Principals' science content knowledge. Principals' science knowledge was measured using the K-4 Physical Science MOSART inventory scores. MOSART is discussed in detail under the instrumentation section.

Table 2.

Description of Independent Variables

Variable	Type	Measure
Type of School	Categorical	Reference Var.=Rural Dummy 1 = Urban Dummy 2 = Suburban
Student SES	Scale	Percentage of students on free/reduced price lunch (0-100)
Student Ethnicity	Scale	Percentage of white students (0-100)
Principal Gender	Dichotomous	Male=0, Female=1
Principal Ethnicity	Dichotomous	White=0, Non-White=1
Total Years Principal	Scale	1-38 years
Years Prin. at Current Sch.	Scale	1-20 years
Years Teaching Experience	Scale	2-36 years
Subjects Taught	Categorical	Reference Var.=Core Dummy 1 = Elementary Dummy 2 = Other
Grades Taught	Categorical	Reference Var. = K-12 Dummy 1 = K-6 Dummy 2 = 7-12
Degrees Held	Categorical	Reference Var.=PhD Dummy 1 = Post-Masters Dummy 2 = Masters
Prin. BARSTL Scores	Scale	32-128 Points
Prin. MOSART Scores	Scale	0-100 Points

Dependent variable.

Students' grade 4 science outcomes. The New York State Education Department reports science scores as a percentage of students achieving one of four state-designated performance levels. Individual or school group raw scores were not available for analysis. This introduces limitations in my data analysis (discussed in depth in limitations section of Chapter Five), as percentages are not naturally normally distributed. The scores were retrieved online from the 2008-2009 Accountability and Overview Report section of the New York State School Report Cards (New York State Education Department, 2010b).

The state designated four performance levels for final test score. Level 1 has a final test score range of 0-44 and describes student performance as Not Meeting the Standards. Students at this level are unable to demonstrate understanding of elementary-level science content, concepts, and skills related to the learning standards and key ideas being assessed. Level 2 has a final test score range of 45-64 and describes student performance as Not Fully Meeting the Standards. Students at this level demonstrate minimal understanding of elementary-level science content, concepts, and skills related to the learning standards and key ideas being assessed. Level 3 has a final test score range of 65-84 and describes student performance as Meeting the Standards. Students at this level are described as demonstrating understanding of elementary-level science content, concepts, and skills related to the learning standards and key ideas being assessed. Level 4 has a final test score range of 85-100 and describes student performance as Meeting the Standards with Distinction. Students at this level are described as demonstrating superior understanding of science content, concepts, and skills (New York State Education Department, 2010c).

Among the four levels of performance, Level 4 was the performance level of choice used in the analysis of this study for several reasons. In addition to being designated by the state as (a) Meeting the Standards with Distinction, (b) demonstrating superior understanding of elementary-level science content, concepts, and skills for the learning standards and key ideas being assessed, (c) having a test score range of 85-100, (New York State Education Department, 2010c), its (d) description of student performance most accurately reflected student understanding of fundamental ideas and skills consistent with the reform movement in science. Since the essence of the science reform movement embodies a philosophy of constructivism that asserts the active process of learning science, any level that allows the inclusion of zero points on the performance component while getting a passing score on the overall test could not be used. Level 4 was the only level of student performance that did not include a score of zero on the performance test in determining the overall result, and finally (e) Level 4 was the only level that was classified independent of other levels on the Statewide Accountability Report. For example, the report lists levels of performance achieved by students under the following categories: Levels 2-4, Levels 3-4, and Level 4. As a result, Level 4 was deemed most appropriate in representing student outcomes.

Experiences that engage students in scientific investigations provide the foundation and background for developing science understandings. Practical experiences in science facilitate understanding of scientific inquiry and knowledge and the interactions between science and society (National Research Council, 1996). The ability to use scientific principles, processes, and skills to demonstrate understanding in the performance component of the New York State Grade Four Elementary-Level Test is

paramount for student understanding consistent with the National Science Education Standards. The performance test specifically assesses student's ability and skills in using hands-on equipment and applying knowledge of science concepts. Therefore, if students are unable to attain points on this component (i.e. get all questions wrong on the performance test), they are not effectively demonstrating scientific skills that are reflective of the process of "doing science" within the focus of inquiry science.

As a result, performance levels that included a score of zero were not included in the analysis of student outcomes. The Level 3 performance classification was characterized by NYSED as Meeting the Standards with a designation of a final test score range of 65-84. This meant students demonstrated understanding of elementary level science content and concepts for the learning standards and key ideas being assessed and demonstrated understanding of the science content, concepts, and skills required for an elementary level academic environment. However, upon examination of the state's Conversion Chart for Determining a Student's Final Test Score (Appendix B), there were 10 possible ways to achieve a Level 3 while earning a zero on the performance test (New York State Education Department, 2010c). Attaining a zero on the science performance test was deemed inappropriate in adequately demonstrating elementary level science skills related to the learning standards and key ideas being assessed as outlined in the National Science Education Standards (National Research Council, 1996).

Similarly, performance Levels 1 and 2 were designated by the state as students Not Meeting or Not Fully Meeting the standards and key ideas being assessed respectively. These levels also included scores of zero on the performance component of the state test and were not reflective of understanding of the process of science.

Therefore, only Level 4 was used as the dependent variable in this study and represents the percentage of students in each school who achieved a superior science score.

Instrumentation

Principals' demographic questionnaire. A demographic questionnaire asked participants to identify their: gender, ethnicity, number of years experience as principal, number of years principal at current school, years teaching experience, subjects/grades taught, and degrees held.

Beliefs about reformed science teaching and learning (BARSTL). Sampson and Benton (2006) developed the beliefs inventory to measure the construct *reformed pedagogical science beliefs* specifically for the population of elementary school teachers. The construct is operationalized by questions on a traditional-reformed pedagogical content belief continuum that identifies teacher beliefs about the teaching and learning of science. The conceptual development of the inventory draws on the philosophy of the national science education reform movement. This reform movement philosophically and theoretically advocates the concept of constructivism (Matthews, 2002; National Research Council, 1996). Constructivism is a broad term used by educators, psychologists, and philosophers among others (Phillips, 1997). However, educators use it to refer to learning that envisions individuals as constructing their own understanding of topics versus understanding being transmitted to them from other sources (Bransford, Brown, & Cocking, 2000).

The traditional stance regarding teaching and learning science envisioned learners as blank slates that accumulated information through teacher-centered instruction. Learners were encouraged to work independently with a heavy reliance on textbooks and

learn by rote memorization. There was also a heavy reliance on the teacher as the main dispenser of knowledge and the curriculum was viewed as a fixed entity that lacks depth. Basic skills were emphasized in this type of instruction.

A reformed perspective of science teaching and learning is philosophically and theoretically underpinned by constructivism (Driver et al., 1994; von Glasersfeld, 1989). Constructivism is characterized as promoting learners to generate their own understanding of science while learning through scientific inquiry (American Association for the Advancement of Science, 1993). Learning is seen as a social and active process that is student-centered. Emphasis is placed on experiencing the environment first-hand and engaging in the process of science. Students are encouraged to observe, infer, experiment, ask questions, construct explanations, test new ideas, and communicate them to others (National Research Council, 1996). The teacher acts as a facilitator and promotes a collaborative environment in the classroom where multiple ideas are encouraged and valued. Furthermore, the curriculum is viewed as being flexible and focuses on depth to promote conceptual understanding.

The BARSTL inventory was developed in seven steps. It began with defining reformed pedagogical content beliefs in accordance with the recommendations and standards for science teaching articulated in the science education reform documents (American Association for the Advancement of Science, 1993; National Research Council, 1996). These documents were used to generate a content matrix of four sub-scales of reformed versus traditional beliefs using likert items. To ensure construct and content validity of the inventory, the content matrix was used to develop the following four sub-scales (1) how people learn, (2) lesson design and implementation, (3)

characteristics of teacher and the learning environment, and (4) the nature of the science curriculum.

In step two, the items for the questionnaire were developed. Based on the content matrix, Sampson and Benton generated a list of 40 statements, using Edwards (1957) *Techniques for Attitude Scale Construction*, to represent teachers' beliefs about science teaching and learning. These statements were organized into the four sub-scales, with each sub-scale consisting of 10 statements, of which five were worded to represent beliefs that are consistent with the science reform movement and five with the traditional perspective. In the next step, the authors evaluated the items for clarity and comprehension. They submitted the 40 draft items along with a letter explaining the review process, criteria and definitions to five graduate students in science education to independently review them for clarity and comprehension. The items were continually revised and resubmitted to the graduate students until clarity and comprehension was achieved for all items.

In order to evaluate the construct validity of the items and the content validity of the scales, Sampson and Benton (2006) created a panel that included three science education professors and four science education graduate students. The reviewers were provided with a similar protocol consisting of a letter of explanation, criteria, and definitions. The reviewers independently evaluated each item using a likert-type response scale. The items were scored as 1, 2, 3, and 4 respectively, for the responses: Strongly Traditional (ST), Traditional (T), Reformed (R), and Strongly Reformed (SR). The items that did not discern between reformed and traditional perspectives were dropped or modified. Similarly, the panel members also independently evaluated the content validity

of the sub-scales using a Likert-type response scale. The subscales were scored as 1, 2, 3, and 4 for the responses: Content Invalid (1), Content Valid with Major Revisions (2), Content Valid with Minor Revisions (3), and Content Valid (4). The authors continuously used the feedback to revise or rearrange the items within each sub-scale to ensure content validity. They also provided the Mean and Standard Deviation scores for all the items as well as the sub-scales.

The fifth step in the development of the inventory consisted of evaluating the first draft. As a result, it was administered to 104 prospective elementary teachers enrolled in an Elementary Science Methods course. Questionnaires that were incomplete were removed, as well as those to which the participant responded to every question using the same response. This resulted in a final count of 95 questionnaires whose data was used to revise the BARSTL inventory.

To initiate the revision of the inventory, the authors developed a guiding question: what is the most reliable and valid combination of items to compose the BARSTL for the purpose of assessing prospective elementary teachers' pedagogical content beliefs about the teaching and learning of science? This question guided the selection of items for the final inventory. The question facilitated further examination of the contribution each item made to reliability and the construct validity of subscales. Item score to total test score correlation and item contribution to total test reliability were used to identify the strongest items. Coefficient α was also utilized to examine the reliability of the inventory for internal consistency. Data from the first draft evaluation was examined using exploratory factor analysis, and the factor properties examined for construct validity. Finally, the authors used the strongest combinations of construct valid and reliable items

that had balanced representation from the content matrix to create the BARSTL questionnaire.

In order to determine the final validity and reliability of the inventory, it was administered to a different group of 146 prospective elementary school teachers from an Elementary Science Methods course. The data obtained from this group was used to further examine the validity and reliability of the final version of the questionnaire. Two internal consistency estimates of reliability were computed: a split-half coefficient and coefficient alpha. The value of the split-half coefficient was 0.80 and the value of coefficient alpha was 0.77, indicating satisfactory internal consistency.

In order to test the theoretical integrity of the inventory, Sampson and Benton (2006) performed a correlation analysis on each of the four subscales to test if reformed pedagogical content beliefs about teaching and learning were a single underlying construct. The R^2 values for the subscales with $p \leq .001$ were as follows: (1) How People Learn, $R^2 = 0.64$, (2) Lesson Design and Implementation, $R^2 = 0.64$, (3) Teachers and The Learning Curriculum, $R^2 = 0.63$, and (4) The Science Curriculum, $R^2 = 0.47$, suggesting that the inventory had good construct validity. Additionally, a confirmatory factor analysis was conducted on the 32 items that made up the inventory using data from the 146 respondents. The result supported that it measured four dimensions of the same construct: *reformed pedagogical content beliefs about teaching and learning*.

To further examine the construct validity of the inventory, results of a confirmatory analysis was used to define the dimensions underlying the instrument to ensure that the items were arranged into the sub-scales appropriately. As a result, a decision rule for the analysis accepted as meaningful any factor loading greater than 0.30.

Based on this analysis, all items within the specific sub-scale measured the sub-scale appropriately.

The final inventory contains likert-type response scale ranges: Strongly Disagree (SD), Disagree (D), Agree (A), Strongly Agree (SA). The four items that represent a reformed perspective of science education are scored as 1, 2, 3, and 4 respectively. The four items that represent a traditional perspective are scored in reverse. Possible scores may range from 32 to 128 points with a median score of 80. Scores are analyzed as total points of the subscales. Higher inventory scores are reflective of reformed pedagogical content beliefs about the teaching and learning of science consistent with science reform documents. Lower scores are reflective of embodying beliefs that are more traditional in the teaching and learning of science.

K-4 physical science misconceptions oriented standards-based assessment resources for teachers (MOSART). The Misconceptions Oriented Standards-Based Assessment Resources for Teachers project was funded by the National Science Foundation to develop a set of specific science subject matter comprehensive assessment tools to identify teachers' strengths and weaknesses in these areas across grade levels (Sadler & Cook-Smith, 2011). The project's aim was to provide National Science Foundation funded Math and Science Partnership Institutes science subject matter assessment tools for teachers and their respective students participating in their professional development. The underlying thinking behind the project recognized that learners are not blank slates but harbor prior knowledge based on their previous experiences on any given science subject matter.

The function of administering these assessment tools was to identify teacher (pre-service or in-service) strengths and weaknesses across grade levels and science disciplines. They may be administered to pre-assess understanding of underlying science concepts prior to participation in professional development activities and workshops as well as after them to determine possible conceptual shifts in understandings. Similarly, the assessments may also be administered to students of participating teachers to determine any effects passed on to them.

The K-4 Physical Science MOSART inventory consists of 20 multiple choice items related to 11 K-4 Physical Science Standards from the National Research Council's National Science Education Standards. It measures the extent to which individuals have understanding of the K-12 National Research Council's Content Standards, American Association for the Advancement of Science's Physical Science Benchmarks, and physical science misconceptions. The assessment items were developed by a team of researchers in the Science Education Department of the Harvard-Smithsonian Center for Astrophysics (Sadler & Cook-Smith, 2011). The psychometricians and research scientists designed the items to ensure alignment with published cognitive research findings and the National Research Council's National Science Education Standards (National Research Council, 1996) that accurately gauge scientific understandings. To ensure validity, science faculty members reviewed the assessment items and revisions were incorporated until all comments were resolved. A literacy expert then reviewed the items for grade-five readability and age appropriateness.

Next, pilot versions of the test questions were administered to over a 100 students in the lowest grade level that the test would be given. Once the data were analyzed,

alternative versions were field tested and administered to over 1000 students across grade levels resulting in more than 1000 multiple choice test questions across a five-year period. The result of these efforts led team members to develop the final assessment inventory.

The K-4 Physical Science inventory provides a useful analysis regarding understanding of physical science concepts. The United States Department of Education uses valid and reliable inventories such as the MOSART for teacher assessment in some of their Mathematics and Science Partnership projects (United States Department of Education, 2009). They are specifically used to measure teacher content knowledge in science. The inventory test questions are correlated to specific National Research Council's Physical Science Standards outlined in the National Science Education Standards Document (National Research Council, 1996).

The K-4 Physical Science inventory consists of 20 multiple-choice questions related to 11 K-4 Physical Science Standards from the National Science Education Standards. It measures understanding of the benchmarks in physical science and may be administered to anyone with a minimum grade five reading level. Possible scores may range from 0 to 100 with each correct answer representing five points. High scores reflect an understanding of the benchmarks and common misconceptions in physical science as outlined by the National Science Education Standards. Comparably, low scores indicate an inadequate understanding of the benchmarks and common misconceptions in physical science as outlined by the National Science Education Standards (National Research Council, 1996).

The method used to measure MOSART inventory performance is a traditional single number scale ranging from 0 to 100. Traditionally, achievement reporting in schools has been through the use of letter symbols or single numbers (Spray, 1969). However, letter symbols are used to represent a range of numbers as well as provide descriptive meanings for each corresponding letter. Consistent with this practice, principals' MOSART scores have been presented as letter symbols. For example, a number grade of 90 and above on the MOSART is represented by an A and indicates Excellent understanding of Physical Science content and common misconceptions. Accordingly, a grade of 80 to 89 on the MOSART is represented by a B and indicates Good or Above Average understanding, a grade of 70 to 79 on the MOSART is represented by a C and indicates Fair or Average understanding, a grade of 65 to 69 on the MOSART is represented by a D and indicates Poor or Low understanding, and finally grades lower than 65 on the MOSART are represented by an F and indicate minimal understanding of Physical Science concepts and common misconceptions as recommended by the National Science Education Standards (National Research Council, 1996; Spray, 1969).

New York State grade 4 elementary level science test. Since assessments across classrooms and schools differ widely in terms of item formats, content, timing, and mode of transmission, high stakes standardized tests are used to assess student outcomes across schools. For the purpose of this research, the New York State Grade 4 Elementary Level Science Test (Appendix C) was the state assessment used to measure yearly student progress across all schools and districts in New York State. Using a uniform assessment facilitated the comparison of student science scores across the state.

The New York State Grade 4 Elementary Level Science Test consists of performance and written components that assess New York State Mathematics, Science, and Technology (MST) learning standards 1, 2, 4, 6, and 7 (New York State Education Department, 2010d). The performance test specifically assesses student laboratory skills. The written component includes multiple choice questions, constructed responses, and extended constructed responses. Although the test is not timed, the written and performance components are each expected to take one hour or less.

The written portion of the test represents approximately 75% of the total grade and predominantly focuses on content-based questions assessing student knowledge and understanding of Standard 4 from the New York State Elementary-Level Core Curriculum. Standard 4 focuses on Physical Setting and Living Environment material. The performance component of the test is open-ended, comprised of mostly application questions, and represents approximately 25% of the total grade. Students' skills in using hands-on equipment and materials are assessed in this portion of the test.

A Conversion Chart for Determining a Student's Final Test Score was developed and used by New York State Education Department (New York State Education Department, 2010c). The raw scales of the Performance and Written components of the test range from 0 to 26 and 0 to 45 points respectively. In order to determine a student's final test score, the raw score from the performance test is selected from the top of the chart, while the raw score of the written test is selected from the left side of the chart. The point where both scores intersect identifies the student's final test score.

Another high stakes standardized science assessment used by the National Center for Education Statistics (NCES) is the National Assessment of Educational Progress

(NAEP) (NCES, 2011a). This is most commonly referred to as the Nation's Report Card and is the only nationally representative assessment of student's knowledge and skills in science, among other subjects. Although it serves as a common yardstick for all states, it is only administered periodically and does not provide school level data or scores for individual schools. Furthermore, only representative samples of students are tested to report their findings. For the purpose of this research, school level data was needed and it was necessary to use a standardized science assessment that facilitated the comparison of all students' science scores across New York State, not just representative samples.

Procedures

Initially, permission was obtained from the Institutional Review Board at Syracuse University on March 31, 2010 to conduct this study. An up-to-date list with names of public New York State K-4, K-5, K-6 elementary schools was subsequently requested from New York State Education Department. The list included names of schools, their district designation (rural, urban, or suburban), grade level, names and email addresses of the respective principals, and county the school resided in.

The information on the list, specifically the names of principals and elementary school designation (K-4, K-5, K-6), were randomly checked against school websites for accuracy. Upon inspection, it was noted that New York City elementary schools/districts were not included in the urban list. Consequently, attempts were made to retrieve the information online but there was no public access to principals' email addresses on school websites (New York City Department of Education, 2010). Websites provided school phone numbers and school email links as the only options to contact schools. For

example, the email link directs website visitors to write an email message within a prescribed template with a send option. The email address of the school is not visible to the sender.

As a result, the New York City Department of Education's Research and Policy Support Group was contacted to obtain a list with names of public K-4, K-5, K-6 elementary schools, their principal's name, and principal's email addresses. Upon their request, a separate Institutional Review Board application was completed to have access to the above information. Approval to conduct this research was granted, but deferred to June 2, 2010. The delay was due to a Satisfaction Survey administered to all New York City principals in late May. The city education department preferred the Satisfaction Survey be closed before any contact was made with their principals regarding additional surveys.

The number of schools from the above lists that met the criteria to be included in this research totaled 2,276 principals and were designated as follows: 181 rural schools, 1,113 suburban schools and 982 urban schools (includes 604 New York City schools). The New York City list was merged accordingly with the alphabetized urban list to create one urban list. Online surveys were emailed during the weeks of April 11, 2010 to June 13, 2010. To manage and maintain order in the implementation of surveys, they were first emailed to principals in suburban districts, followed by urban districts, then rural districts. A random number generator at random.org was used to select names from the three lists.

After compiling the lists of principals, a customized online survey tool called Survey Monkey (www.surveymonkey.com) was used to create two versions, A and B, of

the survey (Appendix A). Both versions of the survey included demographic questions, the Beliefs About Reformed Science Teaching and Learning inventory, and the K-4 Physical Science Misconceptions Oriented Standards-Based Assessment Resources for Teachers inventory. The versions differed only in the order the two instruments were placed within the survey. Version A consisted of demographic questions followed by the BARSTL and inventory and then the MOSART inventory. Version B consisted of demographic questions followed by the MOSART inventory and then the BARSTL inventory. Two versions were created to determine if a bias or preference existed in completion of the survey based on the order of the two inventories.

The demographic questions were purposefully inserted first instead of last in both versions of the survey so participants could review the questions and decide whether they wanted to participate. Placing demographic questions at the beginning of a survey increases the likelihood that individuals will respond to a survey (Frick, Bachtiger, & Reips, 1999). The two instruments included in the survey were self explanatory and restricted to closed answers to reduce incomplete or vague responses (Fowler, 2002). The survey was uncluttered and set up clearly so the respondents could perform the same types of tasks by clicking on a response. This was done to facilitate ease in answering questions and to decrease confusion (Fowler, 2002). A progress indicator bar was also included in the survey to reduce respondent loss (Van Selm & Jankowski, 2006).

Once the surveys were designed, SurveyMonkey generated a URL for each list of principals. This was done to ensure accuracy among data for rural, urban and suburban principals. The end of each URL was then customized with an ID for each principal. This created a unique link for each principal and facilitated identification to compare data with

his or her respective school. The unique link also facilitated an anonymous collection method using email and making the research participant comfortable.

Data collection began with a pre-notification email message explaining the research and upcoming survey (Appendix D). Response speeds and rates are higher when a pre-notification message is sent out prior to an online survey (Mehta & Sivadas, 1995; Sheehan & McMillan, 1999). The email message included information regarding the nature of the research, an incentive of winning one of five \$200.00 gift cards from a drawing of returned surveys, the approximate time of 25-30 minutes to complete the survey, and an assurance of privacy and confidentiality. All these criteria were incorporated in the email as they all increase participant response rate (Couper, Traugott, & Lamias 2001; Crawford, Couper, & Lamias, 2001; Tuten, Bosnjak, & Bandilla, 2000). Additionally, announcing a raffle at the beginning of a study results in a reduced dropout rate (Frick et al., 1999).

A second email was sent to the principals after two days of the pre-notification email (Appendix E). This message included all the information regarding the nature of the research as in the previous pre-notification email and a unique link that directed respondents to the survey. Four days later, a follow-up email was sent to the principals as a reminder (Appendix F). Sending a reminder raises participation in surveys and ultimately increases response rates (Sheehan & Hoy, 1999). The reminder message included the same information regarding the research as the previous emails but did not include the unique link. In case participants wanted the unique link emailed again, they were instructed to send a reply to the email message upon which their unique link was emailed to them again. If a survey was not returned within 7-10 days from the day of the

pre-notification email, another principal/school was selected by generating a new number from random.org.

Initially names were selected in groups of fifty and emails were sent to principals. However, due to a lack of returned surveys and email messages from principals asking to be removed from the list or expressing their lack of interest and/or time, subsequent names were selected in groups of 100 using random.org. This did not improve the rate of return of the surveys. Consequently, 200 names were selected at a time to invite principals to participate from suburban and urban districts. Due to the small number of schools in rural districts, all 181 principals were invited to participate in the research. When New York City principals were selected from the urban list by random.org, their names were set aside for the surveys to be sent after June 2, 2010.

Data retrieval was completed on September 30, 2010 as the last returned survey was in July 2010. Next, surveys were downloaded and variables were recorded in a codebook. The answers were translated into numbers and entered into a SPSS database. Demographic information collected in the survey included: (a) principal gender, (b) principal ethnicity, (c) principal teaching experience, (d) subjects taught, (e) grades taught, (f) years principal at current school, (g) total years experience as principal, and (h) highest degree earned. Additionally, school contextual information retrieved included student ethnicity, percentage of students with Level Four scores on the New York State Grade 4 Elementary Level Science Test, type of school/district (urban, suburban, rural) as identified by New York State Education Department, and percentage of students eligible for free or reduced price lunch, which served as an indicator of their socioeconomic status (SES).

Analysis

Hierarchical multiple regression analysis was used to examine the relationships between students' superior science outcomes and principals' content knowledge in science and beliefs about science teaching and learning. Two demographic variable sets representing schools' contextual and principals' background characteristics were used as predictors. Additionally, principals' beliefs about science teaching and learning and their science content knowledge were also used as predictors. The three sets of predictor variables were entered sequentially into the regression analysis based on the order presented in the conceptual model in Figure 1 (p. 59). The variables that were used in the three steps are presented below:

Step 1. Principals' and schools' demographic variables such as principals' gender, ethnicity, years teaching experience, subjects/grades taught, years principal at current school, total years principal, highest degree held, students' socioeconomic status, students' ethnicity, and school district designation (urban, suburban, or rural).

Step 2. Principals' beliefs about reformed science teaching and learning (Beliefs About Reformed Science Teaching and Learning inventory scores).

Step 3. Principals' content knowledge in science (MOSART inventory scores).

This analysis facilitated the determination of the effects of separate and combined sets of background variables, principals' beliefs about reformed science teaching and learning, and their science content knowledge on students' science outcomes.

In order to address the second question of whether principals' content knowledge in science mediated the relationship between their beliefs about science teaching and learning and students' outcomes, mediational analysis was conducted. Baron and Kenny (1986) define a mediator as the mechanism through which a predictor influences an outcome variable. Mediators tend to determine "how" or "why" a certain variable predicts or causes an outcome variable (Frazier, Tix, & Barron, 2004). However, it is important to note that causal inferences cannot be made on the basis of non-experimental data (Cohen, Cohen, West, & Aiken, 2003).

The mediator examined in this study was principals' science content knowledge. Previous research suggests that principals' knowledge of subject matter is essential in order for them to recognize effective instruction, understand the learning needs of their teachers, and create effective learning environments in their schools (Stein & Nelson, 2003; Waters et al., 2003). Concomitantly, principal's roles have also evolved with reform and accountability measures that hold them responsible for student achievement results (Council of Chief State School Officers, 2008; Elmore, Abelman, & Fuhrman, 1996; Gentilucci & Muto, 2007; Hess & Kelly, 2007; Kaplan et al., 2005; No Child Left Behind, 2002). Within the current policy driven environment, the role of principals' knowledge of science matter cannot be ignored and warrants exploration.

Mediational analysis was performed using multiple regression. The most frequently used method for mediation analysis involves four steps that involve testing several equations (Baron & Kenny, 1986; Frazier, Tix, & Barron, 2004). Baron and Kenny's (1986) framework proposes the use of mediating variables to determine the degree to which they can account for the relationship between antecedent and outcome

variables. In the framework, an independent (predictor) variable X is thought to affect a dependent (outcome) variable Y through the mechanism of a mediating construct M , as shown in Figure 2.

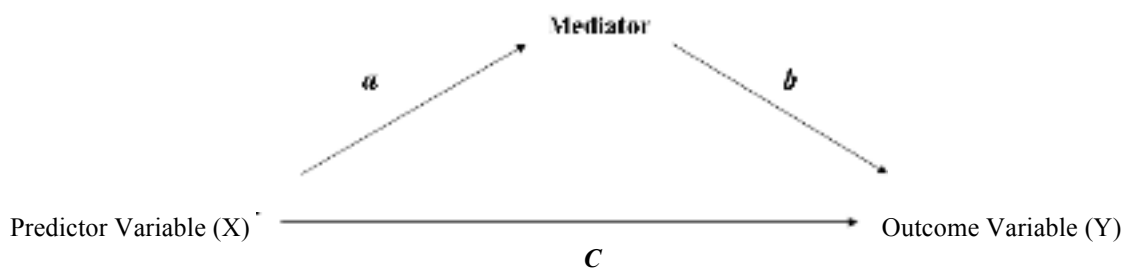

Figure 2. *Mediation Model (Baron & Kenny, 1986)*

The mediation model utilizes three variables with two causal paths leading into the outcome variable. Path a signifies the relationship between the independent variable and the mediator. In order for a variable to function as a mediator, there should be a positive relationship between these two variables. Path b represents the impact of the mediator. Variations in the mediator should account for variations in the outcome variable. Path c denotes the direct relationship of the independent variable to the outcome variable. In complete mediation, the independent variable X does not affect the outcome variable Y after the mediator M has been controlled for. This leads Path c to zero suggesting strong evidence for a single, dominant mediator. However, in partial mediation, Path c is reduced in absolute size but is not zero when the mediator is controlled. Baron and Kenny (1986) state, “a more realistic goal may be to seek mediators that significantly decrease Path c rather than eliminating the relation between the independent and dependent variables altogether” (p. 1176).

This study was partially designed to examine whether principals' content knowledge in science mediates the relationship between principals' beliefs about reformed science teaching and learning and students' outcomes. Principals' beliefs about reformed science teaching and learning (BARSTL scores) represents the predictor variable. The outcome or dependent variable is represented by students' outcomes in science in the form of Level Four New York State Grade Four Elementary Level Science Test scores. Principals' content knowledge in science (MOSART scores) represents the mediator through which principals' beliefs about reformed science teaching and learning affect student science outcomes. Figure 3 represents the application of the mediation model to this study.

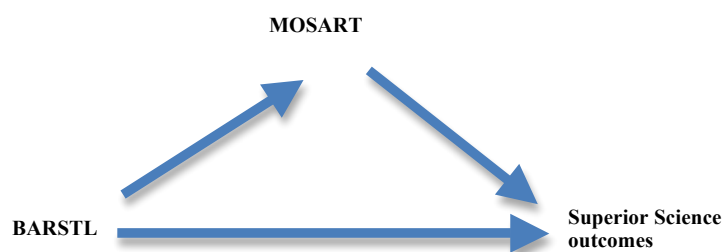

Figure 3. *Proposed Mediation Model of Study.*

In order for a variable to operate as a mediator, the predictor variable should have a significant positive relationship with the potential mediator (Baron & Kenny, 1986; Frazier, Tix, & Barron, 2004). The mediation model establishes whether the initial variable is correlated with the mediator by treating the mediator as if it were an outcome variable. Therefore, in order to examine the first condition for this study, multiple regression analysis was conducted. Principals' beliefs (BARSTL) were used as the predictor variable and principals' science content knowledge (MOSART) was used as the criterion variable. If one or more relationships among the variables are nonsignificant,

mediation is not possible or likely (Baron & Kenny, 1986). This indicates that there is no statistically significant variation between the variables.

Summary of Chapter Three

This research study sought to determine a relationship among elementary principals' beliefs about reformed science teaching and learning, science content knowledge and fourth grade students' superior science scores as measured by the New York State Grade 4 Elementary Level Science Test. Surveys were sent to elementary school principals in the state of New York. The surveys requested demographic information and included two inventories (MOSART and BARSTL). The MOSART assessed principal' science content knowledge and the BARSTL measured their beliefs about reformed science teaching and learning. Student demographic and science outcome data were retrieved online from the Accountability and Overview Report of the New York State School Report Card (New York State Education Department, 2010b). The next chapter will present results from hierarchical multiple regression analysis.

CHAPTER FOUR

Analysis and Results

This chapter presents the results and analysis of this study including explanations for interpreting the findings. Once data were retrieved, hierarchical multiple regression analysis was conducted to assess how prediction by certain independent variables improved on predictions by other independent and mediating variables on students' superior science scores. Chapter Five will discuss the key findings, implications, and limitations of this study and how it adds to the existing literature.

Data were gathered from elementary school principals using an online survey via SurveyMonkey.com. The survey was sent to public K-4, K-5, K-6 elementary school principals in New York State. Of the 2,276 principals solicited by email to participate in the research, 281 emails were bounced back with failure delivery notices ranging from mailboxes being full, school and spam filters, and incorrect email addresses. Of the remaining 1995 principals solicited, only 140 responded to the email requests for a response rate of 7%.

Examination for accuracy and completion of the survey indicated 115 usable surveys. It was noted that four surveys were missing entire BARSTL or MOSART inventories and could not be used. While the remaining surveys were complete in their entirety, two were excluded due to missing science data in their New York State School Report Card. This is typically done for schools with student groups with fewer than five students. Data for these groups is suppressed to protect the privacy of individual students. An additional 18 surveys were eliminated due to incorrect grade allocations of their schools. Although lists of elementary schools in New York State were provided by

NYSED and verified online for their grade allocations, discrepancies still existed regarding their characteristics. The correct grade allocations of some schools became apparent only when their New York State School Report Cards were retrieved. For example, some school websites identified themselves as serving grades K through 5, but were actually only serving grades K through 3. There were several other configurations of incorrect grade allocations listed on official school websites that resulted in exclusion of surveys. This research necessitated the inclusion of grade four in elementary school in order to investigate relationships among principals' beliefs about reformed science teaching and learning, principals' science subject matter knowledge, and grade four students' science outcomes. Finally, one additional survey was excluded due to the principal's previous occupation as a social worker rather than an educator. This study was conceptually predicated on principals having classroom experience as educators. Therefore, non-educators were excluded. Consequently, the above exclusions resulted in 115 principal surveys with a final response rate of 6%.

While this response rate is low, it is not uncommon as the available literature on on-line surveys points to widely varying response rates (Sax, Gilmartin, & Bryant, 2003). Studies have shown that response rates for email surveys vary from a low 6% (Tse et al., 1995) to a high of 75 % (Kiesler & Sproull, 1986). Furthermore, Sheehan (2001) notes that response rates to on-line surveys have significantly decreased since 1986. An increase in surveying in the United States along with an increase in unsolicited e-mail to Internet users is partly to blame for this (Groves, Cialdini, & Couper, 1992; Mehta & Sivada, 1995).

Demographic Characteristics

Principals' Demographic Questionnaire

The demographic section of the survey retrieved background information on principal's personal characteristics. The complete characteristics and descriptive statistics for principals and schools included in this analysis are presented in Tables 3 and 4 in the order of the original survey questions. Additionally, available New York State principal and school characteristics have been added in the tables for comparison purposes with the sample. For example, information such as New York State principal's gender, and degrees held were readily available. However, raw data of New York State principals' average years of teaching experience, administrative experience, years at current school, grades taught, subjects taught, and ethnicity were not available (indicated by N/A in Tables 3 and 4).

In order to facilitate data analysis, some of the variables were broken into categories and assigned dummy variables as indicated in Chapter Three (Table 2). For example, for the category of gender, females were coded as 1 and males as 0. For ethnicity, 93% of the principals identified themselves as white, while the remaining identified themselves as African American, Hispanic and Asian. The lack of diversity in this information resulted in too few categories besides white to be statistically significant. As a result, "ethnicity" was converted into the variable "white" to capture the dichotomy of white vs. non-white. As a result, white was coded as 0 and non-white as 1.

Similarly, the fourth item on the survey requested the identification of "subjects taught" by principals. The responses to this question also resulted in too few categories to be statistically significant. Of the 115 principals, 65% identified themselves as teaching

all common branch or general education elementary school subjects, 15% identified themselves as teaching core subjects such as English Language Arts, Mathematics, Social Studies, Science and the remaining 20% identified themselves as teaching other subjects such as Physical Education, Art, Music, Foreign Language, Computer Technology, Special Education and Resource. Of the 15% of principals who identified themselves as teaching Core Subjects, only 2 taught Science. As a result, “subjects taught” was placed into categories of Elementary Subjects, Core Subjects, and Other Subjects for data analysis with the least frequent category of Core Subjects used as the index or reference variable.

The fifth item on the survey, “grades taught” by principals, revealed similar but not identical responses when compared with the previous item. Therefore, in order to verify the redundancy of “grades taught” with “subjects taught,” a chi-squared test was used to test the null hypothesis of whether the frequency of “grades taught” matched the frequency of “subjects taught.” The null hypothesis was rejected ($\chi^2 = 80.38, p < .001$). These two variables are statistically independent. For example, the responses for “subjects taught” revealed that of the 115 principals, seventy-five (65%) previously taught all common branch subjects in elementary school. However, the responses to “grades taught” revealed eighty-nine (77%) principals taught elementary grades. This suggests that there were principals who were previously elementary school teachers but taught subjects other than the common branch subjects. For example, they taught foreign language, art, physical education, and special education. As a result, grades taught were also placed into categories. The categories included Taught Grades K-6, Taught Grades 7-12, and Taught Grades K-12 where the least category of “Taught

Grades K-12” was used as the index or reference variable.

The principals’ demographic variables such as years of teaching experience, years at current school, and total years of administrative experience had normally distributed frequencies and were entered into SPSS as continuous variables. The last item on the demographic questionnaire inquired about the degrees held by principals. All participating principals earned at least a Masters degree specializing in either Educational Administration, Education, Elementary Education, Science, Business Administration, or Art. Of the 115 principals, 11 earned a doctorate degree of which 8 were Doctor of Education in Leadership (Ed.D.) and 3 were Doctor of Philosophy in Education (Ph.D.). The responses also revealed that 71 principals earned non-degree Post-Masters Licensure Certifications in addition to their Masters degree. The Post-Master’s advanced graduate professional certifications included Certificate of Advanced Study in Educational Leadership (CAS), School Administrator and Supervisor Certificate (SAS), School District Administrator Certificate (SDA), and Sixth Year Program. Once again, the category of Doctorate Degree was used as the index or reference variable.

School Contextual Information

All school contextual information was retrieved online from the New York State Education Department website (New York State Education Department, 2010e). Student’s socioeconomic status (percentage of students eligible for free or reduced price lunch), ethnicity, and Percentage who achieved a Level 4 on the New York State Grade 4 Elementary Level Science Test were obtained from the 2008-2009 New York Statewide Report Card (New York State Education Department, 2010e).

For the student ethnicity variable, the school profile data was used from the Accountability and Overview Report of the New York State School Report Card (New York State Education Department, 2010e). This section lists categories of students' ethnic origin as American Indian or Alaska Native, Black or African American, Hispanic or Latino, Asian or Native Hawaiian/Other Pacific Islander, White, and Multiracial in percentages. Students from participating schools in this study comprised of approximately 1% American Indian or Alaska Native and Multiracial, 11% Black or African American, 10% Hispanic or Latino, 6% Asian or Native Hawaiian/Pacific Islander, and 72% White. Examination of the data revealed that there were too few students in non-white categories to be statistically significant. Therefore, student ethnicity was converted into the variable "percentage of white students" to capture the dichotomy of white vs. non-white students enrolled in school. As the frequency of the percentage of white students was normally distributed, it was entered as a continuous variable into SPSS.

Table 3.

Descriptive Statistics for Elementary School and Principal Demographic Variables

Variable	n	Mean (%)	New York State Mean (%)
Type of School/District			
Rural	9	7.83	N/A
Urban	34	29.57	62
Suburban	72	62.60	N/A
Gender			
Male	44	38.26	31.60
Female	71	61.74	68.40
Ethnicity			
White	107	93.04	N/A
Non-White	8	6.96	
Subjects Taught			
Elementary	75	65.22	N/A
Core	17	14.78	
Other	23	20.00	
Grades Taught			
Elementary K-6	89	77.40	N/A
Secondary 7-12	13	11.30	
All K-12	13	11.30	
Highest Degree			
Doctorate	11	9.56	5.50
Post-Masters Cert.	71	61.74	82.90
Masters	33	28.70	10.60

Table 4

Descriptive Statistics for Principal Years Experience and School Contextual Variables

Variable	Mean (%)	Standard Deviation	NY State Mean (%)
Years Teaching Experience of Principal	13.45	7.06	N/A
Years Principal at Current School	6.15	4.16	N/A
Total Years Principal	9.13	6.45	N/A
Percentage of White Students	72.29	30.06	51.70*
Percentage of Students on Free/Reduced Price Lunch	34.94	28.46	47.00*
Percentage of Students with Level 4 Science Score	65.48	20.02	59.00

* Mean of K-12 schools in New York State inclusive of elementary schools

The dependent variable, percentage of students with a Level 4 science score on the New York State Grade 4 Elementary-Level Science Test, was also retrieved from the Accountability and Overview Report of the New York State School Report Card for each participating principal's school (New York State Education Department, 2010b). This variable was only available as a percentage and presents the greatest limitation in this study that will be discussed in the following chapter.

Findings from Research Questions

This study was conducted to determine if there is a relationship between elementary school principals' beliefs about reformed science teaching and learning and their content knowledge in science on students' fourth grade New York State Science Test scores. The purpose of the online survey administered to principals was to ascertain their personal characteristics, determine their beliefs about reformed science teaching and learning and their science content knowledge. The principal was viewed as an actor within a framework that includes their personal and school characteristics, since previous

research indicates these characteristics influence and shape the school's instructional climate (Boyan, 1988; Hallinger & Murphy, 1986a; Leithwood et al., 1990; Pitner, 1988).

For the statistical tests computed in this research, the alpha level was set to .05 with a one in twenty chance of a type I error, which is common for the field of education (Johnson & Christensen, 2010). In the following section, findings are organized and presented by research questions to facilitate comprehension.

Research Question 1: Does Principals' Content Knowledge in Science and Beliefs About Reformed Science Teaching and Learning Predict Students' Superior Science Outcomes Above and Beyond the Effect of Background Variables Such as Type of School, Student's Socioeconomic Status and Ethnicity, Principal's Gender, Ethnicity, Total Years of Experience as Principal, Number of Years Principal in Current school, Total Years Experience as Teacher, Subjects/Grades Taught, and Degrees Held

In order to address this question, the Misconceptions Oriented Standards-Based Assessment Resources for Teachers and Beliefs About Reformed Science Teaching and Learning inventories were placed within the survey after the demographic questions. Neither inventory was identified by its name and was placed in the survey in its original form to maintain accuracy.

Research question 1a: What is the level of science content knowledge of elementary school principals as determined by the k-4 physical science misconceptions oriented standards-based assessment resources for teachers (MOSART) inventory? This inventory was designed to identify science misconceptions in teachers and students and assess their conceptual shifts in understandings. Similar to

the philosophy underlying the design of the BARSTL inventory, the MOSART inventory also recognizes that scientific mis/understandings may be rectified and clarified through intervention such as preparatory education programs and sustained professional development experiences.

For the elementary school principals in this study, the overall mean K-4 Physical Science MOSART score was 64.74 ($62-67 \pm 14.28$ SD) out of possible 100 points. Figure 4 displays the frequency distribution of scores earned by principals. Concepts assessed in the inventory include Properties of Objects and Materials, Position and Motion of Objects, and Light, Heat, Electricity, and Magnetism (National Research Council, 1996). In order to facilitate analysis in terms of achievement levels, letter grades are used in the discussion. As presented in Figure 5, of the 115 principals who participated in this study, seven earned an A and demonstrated Excellent understanding of K-4 Physical Science content in the National Science Education Standards, 15 earned a B, 28 earned a C, 19 earned a D, and the remaining 46 earned a grade of F.

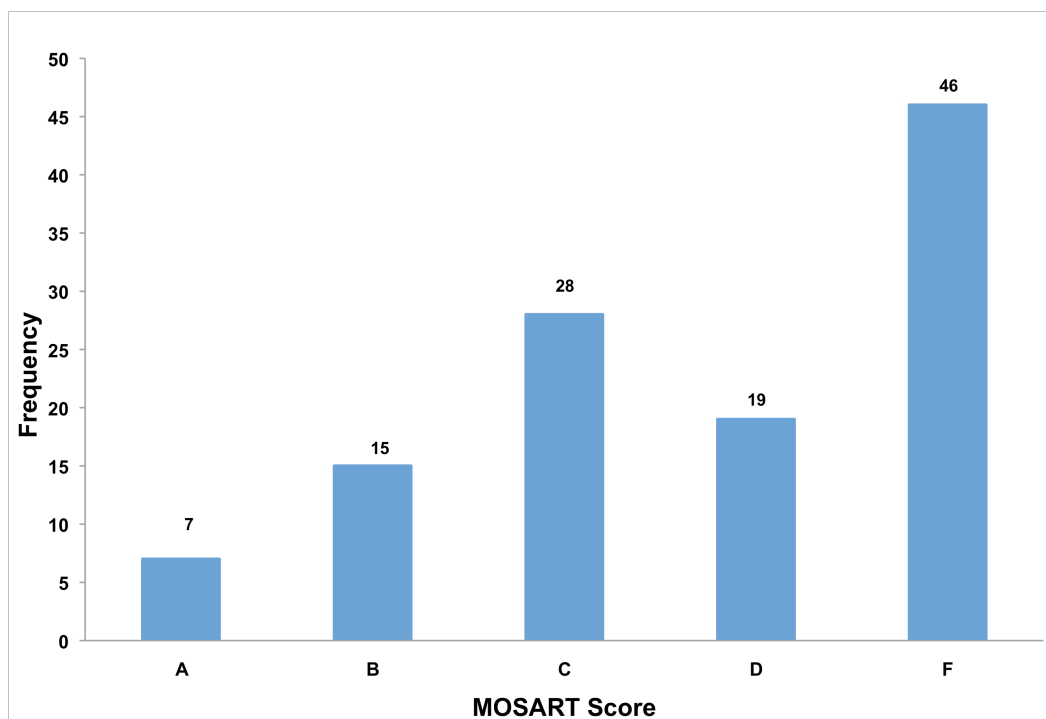

Figure 4. *Frequency Distribution of Principal's MOSART Scores (n=115)*

Ideally, it would have been beneficial to compare principal MOSART inventory scores from this sample with other principals or teachers. However, there is no published report/data available on K-4 Physical Science inventory scores from other samples. As mentioned earlier, the main purpose of the development of these inventories was to provide the United States Department of Education's Math Science Partnership Institutes with assessment instruments for administration to teachers and their respective students. Furthermore, the most recent Math Science Partnership performance summary does not provide individual MOSART scores data since there are several science assessment measures used in their project (United States Department of Education, 2009). Moreover, they list student outcomes in their performance summary as scoring at or above proficient levels. Raw data is not provided in their report.

Research Question 1b: What are principals' beliefs about reformed science teaching and learning as determined by the beliefs about reformed science teaching and learning (BARSTL) inventory? The goal for using this inventory was to gain insight into principals' beliefs regarding science teaching and learning and their relationship to students' science achievement scores. The BARSTL draws on the philosophy of the national science education reform efforts and assesses beliefs about reformed science teaching and learning. It identifies elementary teachers' traditional and reformed pedagogical science beliefs on a continuum, thereby recognizing that philosophical stances may be modified and enhanced through intervention (Sampson & Benton, 2006).

For the elementary principals in this study, the mean BARSTL inventory score was 84.30 (83-85 \pm 4.72 SD) out of a possible 128 points. Figure 5 displays the frequency distribution of principals' BARSTL scores. Although, a majority of principals scored above the mid-point of 80, their scores appear to be hovering around the middle of a traditional-reformed pedagogical content beliefs continuum. Their scores are not remarkably polarizing towards the traditional (scores below 80) or the reformed (scores above 80) perspective of teaching and learning science.

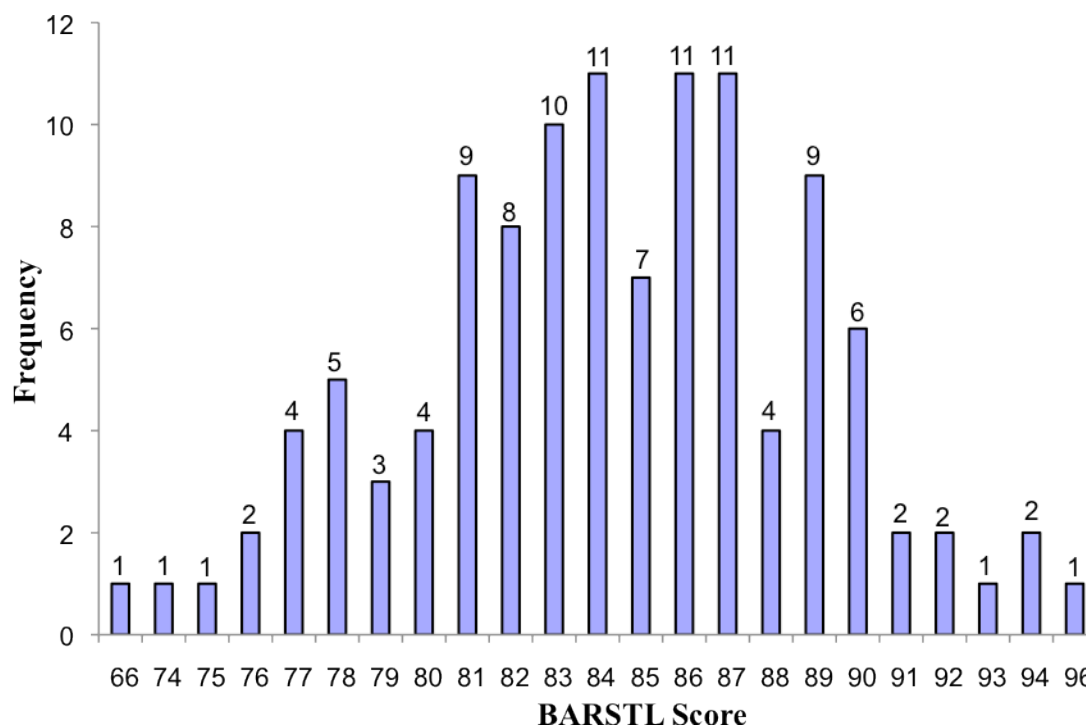

Figure 5. *Frequency Distribution of Principal's BARSTL Scores (n=115)*

As stated previously, inventories were placed after the demographic questionnaire. However, two versions of the survey were created that differed in the order of the placement of the MOSART inventory and the BARSTL inventory to determine if completion of a second large inventory within the survey was affected by the first. A statistical test of this hypothesis was not necessary, as all participants who completed the MOSART inventory first; fully completed the BARSTL inventory and all participants who completed the BARSTL inventory first completed the MOSART inventory.

Next, in order to test a post-hoc hypothesis if a large inventory order would affect the score of a second large inventory, two independent samples t tests were performed to compare the mean scores of large inventories by administration order. The t tests of both passed the Levene's Test for Equality of Variances (Leech, Barrett, & Morgan, 2008;

Levene, 1960), indicating that the variation present in both samples was equivalent. Therefore, it was determined that the order of the tests did not have any effect on the scores of MOSART or BARSTL inventories.

As a result, the null hypothesis that there was no test effect on the BARSTL inventory scores based on the order of the inventory was not rejected. The group that took the MOSART inventory first had a mean BARSTL inventory score of 84.55. The group that took the BARSTL inventory first had a mean MOSART inventory score of 84.05. This is an insignificant difference ($t(115) = .562, p = .575$).

Additionally, the null hypothesis that there was no test effect on the MOSART inventory scores based on the order of the inventory was also not rejected. The group that took the MOSART inventory first had a mean MOSART score of 66.29. The group that took the BARSTL inventory first had a mean MOSART score of 63.25. This is also an insignificant difference ($t(115) = 1.140, p = .257$).

Research Question 1c: What are students' superior science outcomes as determined by the percentage of students achieving a performance level 4 on the New York State grade 4 elementary level science test? This assessment is the measure used in the State of New York to report on student proficiency in elementary science as directed by the Federal No Child Left Behind Act (NCLB, 2001). NCLB requires states to develop and report on measures of student proficiency in several subjects, including science. In order to make Adequate Yearly Progress (AYP), schools must meet the criteria in elementary science in the Grade 4 Elementary Level Science Test. AYP is indicative of satisfactory progress toward the goal of proficiency for all students.

For the principals that participated in this study, the mean percentage of students in schools with a superior Level 4 science score was 65.48 (61-69 \pm 19.93 SD). Figure 6 displays the frequency distribution of percentage of students with Level 4 science scores in participating schools. In comparison to statewide results reported in the 2008-2009 Statewide Accountability Report for New York (Appendix G), 59% of statewide students scored at Level 4 (New York State Education Department, 2010e). The state reported making AYP in Grade 4 Elementary Level Science and reported that all students who were tested met the Participation and Test Performance criterion.

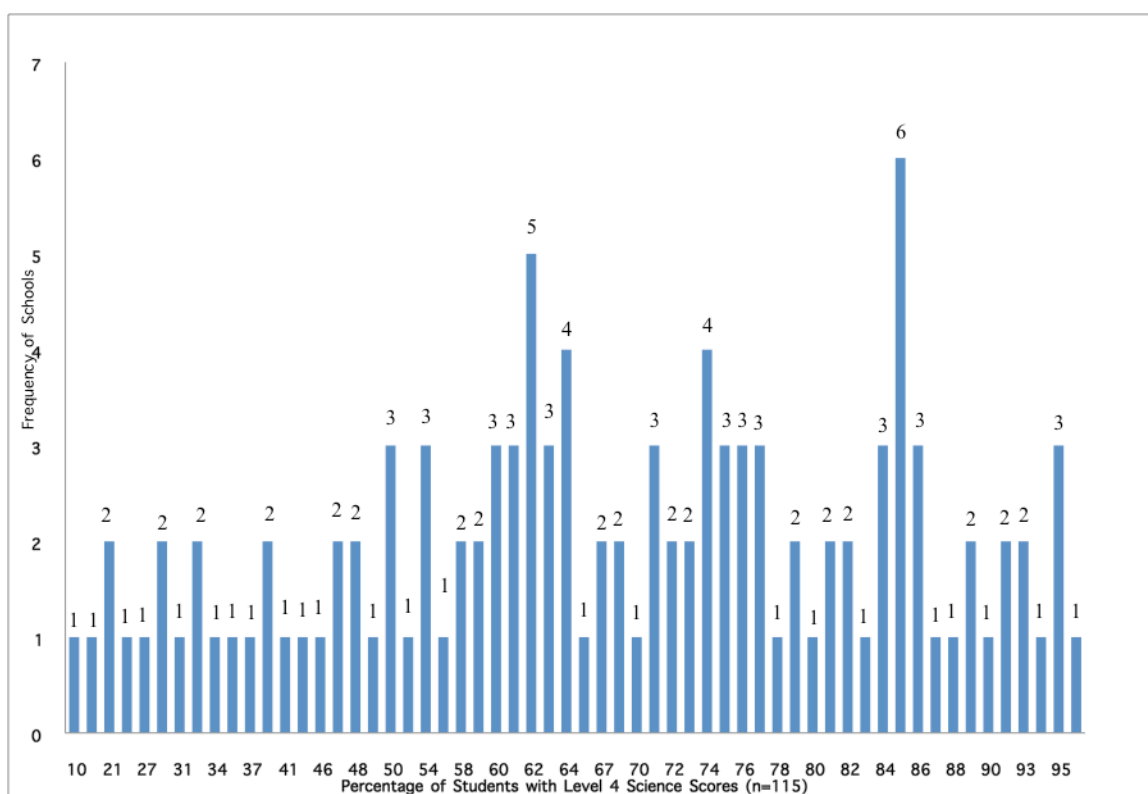

Figure 6. *Frequency Distribution of Percentage of Students with Level 4 Scores (n=115)*

Pearson Correlations

Table 5 displays correlations among continuous and dichotomous variables employed in multiple regression analysis. It is important to keep in mind that correlations do not imply cause and effect but rather simply measure the degree of association between two variables. Typically, an r value of 0.1 is interpreted as a low correlation, r value of 0.3 is a moderate correlation, and an r value of 0.5 is a high correlation (Cohen, 1988, 1992). This study revealed several significant moderate and high correlations. They include the following: (a) schools with non-white principals had the highest percentage of non-white students in their schools ($r = .486, p < .01$), had a higher percentage of students receiving free or reduced price lunch ($r = .448, p < .01$), and had a lower percentage of students with level 4 science scores ($r = .305, p < .01$), (b) schools with a larger proportion of white students had fewer students receiving free or reduced price lunch ($r = .684, p < .01$) and had a higher proportion of students with level four science scores ($r = .353, p < .01$), and (c) schools with more students receiving free or reduced price lunch had a lower proportion of students with level four science scores ($r = .657, p < .01$).

Table 5.

Pearson Correlation of Variables

	1	2	3	4	5	6	7	8	9	10
	Female	Non-White Principal	Years Teaching Experience	Years Principal Current School	Total Years Principal Experience	Percent White Students	Percent Students Free/Red Lunch	Percent Level 4 Science Scores	BARSTL	MOSART
1	1									
2	.145	1								
3	-.009	.104	1							
4	-.009	.014	.131	1						
5	-.170	-.006	-.052	.641**	1					
6	-.128	-.486**	-.057	.096	-.007	1				
7	-.035	.448**	.151	-.118	-.065	-.684**	1			
8	.002	-.305**	-.086	.047	.050	.353**	-.657**	1		
9	.164	-.047	-.048	.082	-.004	.200*	-.229*	.049	1	
10	-.219*	.052	.024	.191*	.185*	.172	-.053	.031	.144	1

* $p < .05$; ** $p < .01$.**Hierarchical Multiple Regression Results and Analysis**

In order to investigate how principals' beliefs about reformed science teaching and learning and science content knowledge predict students' science achievement scores when controlling for background (antecedent) variables, a hierarchical linear regression was performed. The hierarchical multiple regression analysis summary is presented in Table 6. Background (antecedent) variables such as principals' characteristics (gender, ethnicity, years experience as a teacher, subjects taught, grades taught, years at current school, total years experience as principal, degrees earned) and students' characteristics (SES, ethnicity, type of school) were initially entered into the regression equation alone. This was done to control for them as previous research highlights how leadership is shaped by these personal and contextual factors. When entered alone, the background variables significantly predicted student science outcomes, $F(15,99)=6.93$, $p = .000$, $R^2 = 52\%$. In step two of the hierarchy, principals' BARSTL scores were added to the model

and did not improve the prediction, $\Delta R^2 = .003$, $F(1,98) = .581$, $p = .448$, $R^2 = 52\%$. In the third and final step of the hierarchy, principals' MOSART scores were added to the model and also did not improve the prediction, $\Delta R^2 = .000$, $F(1,97) = .045$, $p = .832$, $R^2 = 52\%$.

The full model explained 52% of the variance in percentage of superior science scores, with free or reduced price lunch and school type as the only significant individual predictors in the model. Schools with a higher percentage of students who qualify for free or reduced price lunch have lower percentage of students in the superior science score range. Additionally, urban schools outperformed rural schools by 16 percentage points. This indicates that urban schools have higher percentage of students in the superior science score range than their rural counterparts. Furthermore, suburban schools also outperformed rural schools by 12 percentage points of students in the superior science score range. Both school types outperformed their rural counterparts by having higher percentage of students in the superior science score range.

Table 6.
Hierarchical Multiple Regression Analysis Summary for Principal' Science Content Knowledge and Beliefs About Reformed Science Teaching and Learning, Controlling for Antecedent Variables, Predicting Student' Superior Science Scores

Variable	<i>B</i>	<i>SEB</i>	β	R^2	ΔR^2
Step 1				0.512	0.512
Female	-3.028	3.213	-0.074		
Non-White Principal	-5.166	6.795	-0.066		
Post-Masters Cert.	-6.076	5.095	-0.148		
Masters Degree	-7.121	5.693	-0.162		
Years Teaching Exp.	0.199	0.216	0.070		
Taught K-6 Grades	10.155	5.907	0.213		
Taught 7-12 Grades	3.329	7.066	0.053		
Taught Elem. School Subject	-6.684	5.792	-0.160		
Taught Other Subjects	1.332	5.858	0.027		
Years Principal at Current School	-0.139	0.466	-0.029		
Total Years Principal Experience	0.112	0.302	0.036		
Urban School	17.035	6.920	0.390*		
Suburban School	12.867	6.218	0.312*		
Percent White Students	-0.054	0.078	-0.081		
Percent Students Free/Reduced Lunch	-0.525	0.097	-0.746**		
Constant	80.830	15.330			

Table 6.
Hierarchical Multiple Regression Analysis Summary for Principal' Science Content Knowledge and Beliefs About Reformed Science Teaching and Learning, Controlling for Antecedent Variables, Predicting Student' Superior Science Scores

Variable	<i>B</i>	<i>SEB</i>	β	R^2	ΔR^2
Step 2				0.515	0.003
Female	-2.502	3.293	-0.061		
Non-White Principal	-4.252	6.915	-0.054		
Post-Masters Cert.	-5.935	5.110	-0.145		
Masters Degree	-7.559	5.734	-0.172		
Years Teaching Exp.	0.186	0.217	0.065		
Taught K-6 Grades	8.938	6.131	0.188		
Taught 7-12 Grades	1.618	7.428	0.026		
Taught Elem. School Subject	-6.770	5.805	-0.162		
Taught Other Subjects	0.209	6.053	0.004		
Years Principal at Current School	-0.118	0.468	-0.024		
Total Years Principal Experience	0.100	0.303	0.032		
Urban School	16.584	6.960	0.380*		
Suburban School	12.545	6.246	0.304*		
Percent White Students	-0.047	0.079	-0.070		
Percent Students Free/Reduced Lunch	-0.526	0.097	-0.748**		
BARSTL	-0.260	0.341	-0.062		
Constant	102.874	32.741			

Table 6.
Hierarchical Multiple Regression Analysis Summary for Principal' Science Content Knowledge and Beliefs About Reformed Science Teaching and Learning, Controlling for Antecedent Variables, Predicting Student' Superior Science Scores

Variable	B	SEB	β	R^2	ΔR^2
Step 3				0.515	0.000
Female	-2.360	3.376	-.058		
Non-White Principal	-4.539	7.078	-.058		
Post-Masters Cert.	-5.975	5.138	-.146		
Masters Degree	-7.451	5.784	-.169		
Years Teaching Exp.	0.186	.218	.066		
Taught K-6 Grades	9.180	6.265	.193		
Taught 7-12 Grades	1.643	7.466	.026		
Taught Elem. School Subject	-6.856	5.847	-.164		
Taught Other Subjects	.188	6.083	.004		
Years Principal at Current School	-.127	.472	-.026		
Total Years Principal Experience	.097	.305	.031		
Urban School	16.308	7.113	.373*		
Suburban School	12.423	6.302	.302*		
Percent White Students	-.050	.081	-.075		
Percent Students Free/Reduced Lunch	-.526	.098	-.748**		
BARSTL	-.268	.344	-.064		
MOSART	.024	.114	.017		
Constant	114.615	30.753			

*p < .05; **p < .01.

Bivariate Analysis

Bivariate analyses were conducted to assess correlations among the three target variables. Specifically, they were performed to determine whether there was a relationship between principals' BARSTL scores and students' outcomes and principals' MOSART scores and students' outcomes. Results indicated that the two variables, principals' science beliefs and knowledge, are not linearly related to students' outcomes.

Research Question 2: Does principals' Content Knowledge in science Mediate the Effects of their Beliefs About Science Teaching and Learning in Predicting Students' Superior Science Outcomes Above and Beyond the Effect of Background Variables Such as Type of School, Student's Socioeconomic Status and Ethnicity, Principal's Gender, Ethnicity, Total Years of Experience as Principal, Number of Years Principal in Current School, Total Years Experience as Teacher, Subjects/Grades Taught, and Degrees Held

In order to test for mediation, core conditions have to be met (Baron & Kenny, 1986; Frazier et al., 2004). The predictor and mediator each should be related to the dependent variable. In this study, BARSTL scores represented the predictor variable, MOSART scores represented the mediating variable, and students' science outcomes represented the dependent variable. Simple regression analysis revealed no significant relationships among the variables. Further steps in establishing mediation were not conducted, as the core conditions were not met. Therefore it was concluded that principals' science content knowledge does not mediate the relationship between principals' beliefs about reformed science teaching and learning and students' superior science outcomes. The data failed to support the proposed mediation model for this study.

Summary of Chapter Four

Chapter Four presented the results of this study to determine if a relationship exists between elementary principals' content knowledge in science, beliefs about reformed science teaching and learning, and fourth grade students' science scores. The chapter was organized to present principals' survey data by research questions. In the analysis of this data, the following findings were revealed.

1. Principals' beliefs about reformed science teaching and learning and science subject matter knowledge did not contribute to predicting students' superior science scores.
2. Principals' science subject matter knowledge did not mediate the relationship between their reformed beliefs about science teaching and learning and superior science scores. There was no statistically significant variation among the variables. The data failed to support the proposed mediation model of this study.
3. There was 52% variance in percentage of students with superior science scores that was explained by school characteristics with free or reduced price lunch and school type as the only significant individual predictors.
4. Principals' mean BARSTL inventory score was neither traditional nor reformed based at 84.30 (83-85 \pm 4.72 SD).
5. Principals' mean K-4 Physical Science MOSART inventory score was low at 64.74 (62-67 \pm 14.28 SD).
6. There was no test effect on principals' beliefs and science knowledge based on the order of inventory in the two versions of the survey. This

indicates that versions A or B of the survey did not have any effect on principal's BARSTL or MOSART scores.

In the upcoming chapter, the significance of these findings will be discussed and placed within a context of current and future research and their implications.

CHAPTER FIVE

Discussion, Limitations, and Conclusions

Introduction

This chapter begins with a discussion of the findings of this study and compares them with previous research in this domain. It highlights how this study adds to the current knowledge base in science instructional leadership. This is followed by the limitations section that addresses the methodological strengths and limitations of this study and how the findings should be interpreted within the broader context of current literature. Finally, the conclusion section discusses recommendations for future research endeavors.

Discussion

Findings. The key findings in this study indicate that for this sample there is no relationship among principals' beliefs about science teaching and learning, principals' science subject matter knowledge, and superior science scores. This indicates that principals' science beliefs and knowledge have no influence on students' superior science scores. This also suggests that principals' science knowledge does not mediate the effects of their beliefs in predicting superior science scores. However, a 52% variance in the percentage of students with superior science scores is explained by school characteristics, with free or reduced price lunch and school type as the only significant individual predictors.

The results of this study indicate that schools with a higher percentage of students who qualify for free or reduced price lunch have a lower percentage of students in the superior science score range. This finding supports previous research that has established

that socioeconomic status is a strong predictor of student achievement (OECD, 2011; Rumberger & Palardy, 2005; Sirin, 2005). Sirin (2005) conducted a meta-analytic review of research on socioeconomic status and academic achievement published between 1990 and 2000. Student characteristics, such as grade level, race, and school location, were analyzed as moderators of the relationship between socioeconomic status and academic achievement. Grade level had a Mean ES of .28, minority status had a Mean ES of .24, and school location had a Mean ES of .25. Overall, the ES of the study reflected a medium level of association. Other studies have also highlighted that students with higher socioeconomic status tend to have higher scores on standardized tests and are more likely to pursue higher education (Blossfeld & Shavit, 1993).

Another independent variable, school type (urban, suburban, rural), provided insight into students' social and economic status and potential academic achievement. Although considerable research points to the challenges in academic achievement within urban schools at the student, teacher, and administrative level, this study revealed that urban schools outperformed rural schools by 16 percentage points and suburban schools outperformed rural schools by 12 percentage points in science outcomes. This suggests further research is needed regarding alternative contributing factors to student performance that go beyond school type or urbanicity. Exploring new constructs that may be more powerful shapers of student performance within urban and suburban districts could provide insight into mitigating the effects of school type.

For example, Goddard, Sweetland, and Hoy (2000) have demonstrated that academic emphasis was an important construct in improving mathematics and reading scores in urban elementary schools. Academic emphasis within a school consisted of

maintaining a climate shared by administrators, teachers, and students that focused on the importance of academics. Data were obtained from teachers and students from 45 elementary schools. Hierarchical linear modeling revealed that academic emphasis accounted for 47.4% and 50.4% of the between school variability in mathematics and reading, respectively.

Similarly, another construct, academic optimism, has also demonstrated gains in student achievement while controlling for socioeconomic status, previous achievement and urbanicity. Hoy, Tarter, and Hoy (2006) investigated academic optimism that consists of academic emphasis, collective efficacy beliefs, and faculty trust to create a unified positive academic environment. Confirmatory factor analysis via structural equation modeling revealed that academic optimism made a significant contribution to student achievement. The test of the model for mathematics and science achievement was an excellent fit to the data and overall the predictor variables accounted for 67% of the variance in student achievement. The models for reading, social studies, and writing achievement were also an excellent fit to the data and the predictor variables accounted for 54% of the variance in student achievement.

Another study examined the effect of the school and neighborhood climate on academic achievement among urban elementary school students (Milam, Furr-Hoden, & Leaf, 2010). A survey assessed students' perceptions of school and community safety, an observational assessment of neighborhood characteristics measured community violence and academic achievement was measured using standardized state exams. Linear regression models using perceived school and neighborhood safety had coefficients that ranged from 15.4 to 22.8%. Schools with higher perceived safety had a higher percentage

of students passing the reading and mathematics exam. Schools with higher violence ratings showed a decrease on academic performance. Each unit increase in the violence increase score was associated with a 4.2% ($p = 0.111$) decrease in the percentage of third grade students performing proficient or advanced on the reading exam. A decrease by 4.6% ($p = 0.070$) was seen in the reading performance among fourth graders and a decrease of 8.7% ($p < 0.001$) among fifth graders.

The above findings indicate that in order to fully understand academic achievement across school types, research should go beyond the typical school level characteristics or variables (Hoy et al., 2006). For example, characteristics such as parental involvement, after school programs, enthusiastic leadership, ongoing teacher professional development, instruction promoting active student learning and even student religious commitment have moderated the effects of school type challenges and improved academic achievement across disciplines (Hoy et al., 2006; Jeynes, 2003; Milam et al., 2010; Ruby, 2006; Teale & Gambrell, 2007).

It is plausible that the urban and suburban schools in this study may have had one of the above or other unexplored teacher, principal, and/or school level characteristics that mitigated the effects of school type. However, since I did not measure any of the above constructs, further research is needed to better understand factors that may contribute to student achievement above and beyond the typical characteristics. It is important to remember that schools are dynamic institutions with unique contexts that require and present a different set of challenges for principals, teachers, and students alike. As a result, there may not be a single set of identifiable characteristics that promote academic success across and within school types. Research attempting to identify specific

principal, teacher, or school characteristics and behaviors to promote discipline specific academic achievement may only be limiting our understanding of student success. An integrated research approach that incorporates all the constituencies operating within the school environment across all disciplines may provide a holistic paradigm to better understand overall leadership and student achievement.

Other findings in this study revealed principals' beliefs about science teaching, as measured by the BARSTL, and knowledge of science, as measured by the MOSART. The mean BARSTL score for principals in this study was 84.30 ($83-85 \pm 4.72$ SD) out of a possible 128 points. This score is slightly above the median of 80 on a traditional-reformed pedagogical science beliefs continuum. Reviewing the frequency distribution of scores reveals that principals' beliefs appear to be neither excessively traditional nor reformed based. The scores are concentrated around the middle of the continuum.

This indicates that in of itself, principals' beliefs about the teaching and learning of science are not consistent with the recommendations outlined in the National Science Education Standards. For example, a central theme in the standards advocates, "teaching should be consistent with the nature of scientific inquiry" (American Association for the Advancement of Science, 1989, p. 147). Learning science is seen as a social and active process and "is something students do, not something that is done to them" (National Research Council, 1996, p.22). High BARSTL scores most accurately reflect an understanding and embodiment of inquiry teaching that is consistent with the recommendations outlined in reform documents. Therefore, for the most part, principals in this study do not share beliefs about the teaching and learning of science that are consistent with the national reform movement in science education.

However, it is important to note that principals in this study also do not share the philosophical stance of traditional science teaching and learning. A traditional stance of teaching is reflective of didactic instruction where the teacher is the transmitter of knowledge. Emphasis is placed on lectures involving note taking where students answer questions posed by teachers (Sungur & Tekkaya, 2006). BARSTL scores reflective of embodying this stance tend to be low. Since principal's BARSTL scores were neither very low nor high indicates that they do not embody deeply ingrained traditional or reformed based science philosophical stances. They tend to remain in the middle of the continuum.

When compared with other published BARSTL scores, principal's scores were lower. For example, Sampson and Benton (2006) administered the inventory to a sample of 146 pre-service elementary teachers enrolled in a science methods course as part of an undergraduate elementary education degree. They used the scores from this sample to establish the reliability and validity of the instrument as well as provide a standard of performance against which to assess inventory scores achieved by others. The mean score for the pre-service elementary teachers was 94.4 (80-112 \pm 7.30 SD) out of a possible 128 points.

Establishing and further exploring principals' beliefs using the BARSTL in an integrated study incorporating teachers, students, and principals may be a valuable tool for principal preparation programs working in practical and research settings. Since beliefs are "the best indicators of the decisions individuals make throughout their lives" (Pajares, 1992, p. 307), supplementing the identification of principals' beliefs with open-ended interviews concerning science teaching and learning is recommended. This may

provide insight into the reasoning behind principals' decision-making related to selecting appropriate professional development, science textbooks, hiring and evaluating science teachers, and determining what and how science should be taught in their schools. The potential findings could lead to supporting principals by providing relevant professional development to keep them informed about best practices that are aligned to the national science reform movement.

Next, principals' science knowledge was also assessed using the MOSART. The mean K-4 Physical Science MOSART inventory score for principals was 64.74 (62-67 \pm 14.28 SD) out of a possible 100 points. Unlike the BARSTL, principal's MOSART scores were dispersed across a wider range. Although principal performance ranged from failing to an exceptional understanding of K-4 Physical Science content, the majority (n=65) earned a grade of either a D or F. This indicates a lack of fundamental understanding of K-4 Physical Science concepts and reflects poor or failing performance on recognizing or understanding common misconceptions. Furthermore, these grades suggest that principals themselves harbor prevalent misconceptions assessed in the inventory. Similarly, principals with a grade of C (n=28) also demonstrate a lack of recognition of common misconceptions despite being classified as having average understanding of content. Finally, of the remaining 22 principals, principals with a B (n=15) display having good or above average understanding of K-4 Physical Science concepts. Although they did not have mastery of the content or full awareness of common misconceptions as principals who earned an A (n=7), their conceptual understanding was acceptable.

Upon further analysis, identification of the most common misconceptions held by principals indicated that they were from Learning Standard Seven of the National Science Education Standards that states, “Sound is produced by vibrating objects. The pitch of the sound can be varied by changing the rate of vibration (National Research Council, 1996).” The MOSART adds common misconceptions as distracters within its assessment items in order to reveal them. Therefore, this finding suggests that principals have deep-rooted misconceptions in this topic. Physical science concepts tend to be more abstract in nature among the various science branches and can be particularly difficult for learners to understand (Stein, Larrabee, & Barman, 2008). They are also prevalent across a range of topics among elementary school teachers (Heller & Finley, 1992; Kruger, Summers, & Palacio, 1990; Lawrenz, 1986). While most misconceptions are common in children, they tend to be stable ideas that are not necessarily modified despite repeated instruction (Driver, Guesne, & Tiberghien, 1985). They have also been known to remain stable from childhood into adult life, alerting scholars to the importance of addressing science understanding prior to teaching in the classroom (Halloun & Hastenes, 1985; Stein et al., 2008). Therefore, it is not uncommon for teachers to hold the same misconceptions as their students (Apelman, 1984; Burgoon, Heddle, & Duran, 2011; Smith, 1987). Furthermore, one would not expect these physical science misconceptions to disappear in principals as most of them often ascend to their current position after being employed as classroom teachers (Baker, Punswick, & Belt, 2010).

Although the findings of this study did not support the proposed relationships among principals’ science beliefs, knowledge, and superior science scores, it is the first to

explore principals' science knowledge using the MOSART and highlights that fundamental science misconceptions are held by school leaders. This finding cannot be ignored in the field of educational leadership that is confronted with serious challenges in the 21st century. It is recommended that principals' science knowledge be further explored in their daily decision-making and interactions with teachers and students. Since principals are being inundated with responsibilities ranging from reading about instructional practice, being well-versed in successful strategies related to teaching and learning, conducting observations in classrooms, choosing relevant professional development for teachers, providing teachers opportunities to collaborate, and to track student test scores (Council of Chief State School Officers, 2008; Institute for Educational Leadership, 2000; National Association of Elementary & Secondary Principals, 2008; National Policy Board for Educational Administration, 2002; National Research Council, 1996, 2002; National Staff Development Council, 2000), future research incorporating a multi-disciplinary research approach should be implemented.

Finally, Pearson Correlations were also conducted among continuous and dichotomous variables employed in this research. Several high and moderate degrees of association were found among several variables. For example, schools with more students on free or reduced price lunch had a lower proportion of students with level four science scores ($r = .657, p < .01$). These results indicate that student science achievement is likely to worsen under conditions of lower socioeconomic status. In the 2000 U.S. National Assessment of Educational Progress (NAEP) report, also known as the Nation's Report Card, 70% of students attending high poverty urban schools rated Below Basic in science (O'Sullivan, Lauko, Grigg, Qian, & Zhang, 2003).

While there may be exceptions, high poverty and high minority student populations face greater challenges than their low poverty and low minority counterparts (Lippman, Burns, & McArthur, 1996). For example, this study found that schools with a larger proportion of white students had fewer students on free or reduced price lunch ($r = .684, p < .01$) and a higher proportion of students with level four science scores ($r = .353, p < .01$). Furthermore, other associations indicated that schools with non-white principals had the highest percentage of non-white students in their schools ($r = .486, p < .01$), had a higher percentage of students on free or reduced price lunch ($r = .448, p < .01$), and had a lower percentage of students with level 4 science scores ($r = .305, p < .01$).

Amid many factors, some of the differences in student achievement in science in the U.S. have existed due to characteristics of neighborhoods, teacher preparation, student backgrounds, and school resources (Lippman et al., 1996). While children in affluent suburban schools consistently achieve higher than their disadvantaged urban counterparts (United States Department of Education, 2000), this study highlights that there may be more powerful shapers of academic success that mitigate the effects of school type. In order to better understand student achievement in science and all disciplines, future research should employ a mixed methods approach and investigate overall student achievement. For example, teacher education, teacher characteristics, educational administration, leadership characteristics, and student characteristics should be studied across all content areas concomitantly. Interdisciplinary research has the potential to uncover hidden constructs that mitigate the effects of typical challenging characteristics and promote a better understanding of overall effective instructional leadership and student achievement.

Strengths and Limitations

Strengths

This study is the first to assess principals' beliefs about reformed science teaching and learning and science knowledge using the BARSTL and MOSART inventories, respectively. Since principals' science beliefs and understandings have been one of the least studied disciplines in instructional leadership (Burch & Spillane, 2001; Spillane, 2005), these findings provide a foundation to explore the nature of these constructs within principals' daily decision-making.

Limitations

The major limitations encountered in this study include a (a) low response rate, (b) the resulting sample was not representative of New York State population of principals and schools, (c) choice of inventories used, and (e) the most significant limitation and cause for concern was the availability of the dependent variable as a percentage rather than a continuous variable. As a result, this research was particularly constrained by measurement of the dependent variable.

Response rate. Using online survey methodology resulted in a response rate of only 7%. While this is not uncommon for online surveys (Sax et al., 2003), it may lead to inaccurate results due to the bias inherent in the participants that did and did not respond. While the respondents may have been limited to those with access to technology and time to complete the survey, the nature of bias associated with non-response could be attributed to a number of factors. Despite improved communication technologies allowing the incorporation of anonymous surveys, a lack of comfort or experience in using technology may still persist, leading to marking unintentional responses and/or

avoiding the survey altogether. Computer access may also be to blame as some schools may lack monetary resources for equipment and connectivity of the Internet. Other factors such as fear of being identified, particularly when respondents are answering assessment questions regarding personal beliefs and subject matter knowledge may exist. Consequently, it is unlikely that the results of this study provide credible statistics about the characteristics of the population studied as a whole.

Population. The sample of this study is clearly not representative of the New York State population of principals and schools. As displayed in Tables 3 and 4 in Chapter Four, when compared with New York State, a higher proportion of participating principals who completed the survey were female, white, and had Post-Masters degree certification. Similarly, higher proportions of schools in this study were comprised of suburban districts. Therefore, generalized propositions about this study cannot be made. The results of principals' beliefs and science knowledge assessed in this study are restricted to this sample.

Inventories. The BARSTL and MOSART inventories may not be the most effective tools for assessing principals' science beliefs and knowledge. Finding survey instruments that accurately captured these constructs in elementary school principals was challenging at best since they do not exist. The options were either to design a survey instrument specifically for elementary school principals or use one that was created for a population that most closely resembled them. Since most principals rise from the ranks of teachers and nearly 85% of all administrators in New York start their careers as teachers (Baker et al., 2010), survey instruments that were designed for elementary school teachers were used. The K-4 Physical Science MOSART was designed for elementary

school teachers and their students and the BARSTL was designed for pre and in-service elementary school teachers.

There is also no way of knowing whether using an instrument that assessed physical science knowledge versus knowledge of other science branches contributed to the low response rate. In order to maintain interest in the survey, astronomy and earth science MOSART inventories were not included in the survey. Since physical science misconceptions are some of the most prevalent among elementary school teachers (Lawrenz, 1986), the K-4 Physical Science MOSART was the logical choice.

Similarly, the BARSTL inventory may not be the best representation of principals' beliefs about reformed science teaching and learning as its target population is elementary school teachers.

Dependent variable. Of all the limitations, the dependent variable of percentage of students with superior science scores is the most limiting. Prior to 2006, New York State report cards listed students' science performance as counts of students, rather than percentage of students, achieving one of four levels. The four levels were reported independently and provided a straightforward understanding of students' science achievement.

However, after 2005 the format and distribution of performance levels were revised on the New York State report cards. Raw data were not available online or upon request for any given level of achievement. Therefore, although percentages are not naturally normally distributed and not likely to have consistent variation of the normal curve, percentage of students with superior science scores (Level 4) was used as the

dependent variable. This no doubt increases the type II error rate since a normal distribution analysis is being applied to a non-normal distribution.

Another limitation is the examination of association between principals' beliefs and knowledge and only superior science scores (Level 4). This limited the scope of the knowledge claim to characteristics of principals and schools that are associated with only superior science knowledge. The decision to use only level 4 scores was due to several factors. For example, incorporating all performance levels (1-4) would have provided the identification of principal and school characteristics associated with a wide range of students' science scores and be more sensitive to the differences. However, 88% of New York State students scored at or above level 3. Since the bulk of them were designated in this range, it would be challenging to determine a variance in their science scores.

Furthermore, New York State reports its science scores as percentages of students achieving one or more of four state designated levels: Level 1 has a final test score range of 0-44, Level 2 has a final test score range of 45-64, Level 3 has a final test score range of 65-84, and finally Level 4 has a final test score range of 85-100. However, when students' outcomes are reported in the Statewide Accountability Report (Appendix G), they are presented as percentages of students achieving one or more performance levels inclusive of Level 4. For example, percentages of students are listed under the following headings: Achieving Levels 2-4, Levels 3-4, and Level 4. Since Level 1 is not reported and all designations are inclusive of Level 4, it was challenging to accurately ascertain the percentage of students performing at each distinct level. Level 4 is the only performance indicator that is distinct from other levels and reported independently.

Additionally, the distribution of the science scores at level 4 is also problematic. A score range of 85-100 is not discriminatory in terms of determining students' science knowledge. This wide range does not accurately convey the performance of a students' level of science understanding as it encompasses letter grades of A and B. Traditionally, grades are divided into distinct levels of comprehension to illustrate specific student understandings.

Future Research

Within the present era of accountability, principal's work continues to be anchored in issues of supervision, learning, teaching, professional development, curriculum, assessment and student achievement (Chance & Anderson, 2003). Principals are expected to lead, enact, and support effective reform strategies recommended by national organizations. It can be agreed upon that this requires them to recognize as well as understand the recommendations of educational reform movements in order to lead teachers and hold them accountable for implementing best practices. School leadership research in mathematics and literacy instruction confirms principals' "subject matter specific thinking" leads their work and informs best practice (Burch & Spillane, 2001, 2003;1996; Spillane, 2005; Stein & Nelson, 2003). Therefore, if principals are being informed by their mathematics and literacy content knowledge, then why is this not occurring in science?

Consequently, we need to understand more about what's happening in New York State elementary schools. For example, as stated in Chapter Two, preliminary results from one of the largest math and science studies in the U.S., that compared Alabama Math, Science, and Technology Initiative (AMSTI) schools with non-AMSTI schools,

with approximately 30,000 students and 780 teachers in 82 schools, conducted over five years has indicated that improved science teaching in schools consecutively improves mathematics, ELA and science scores. The exploratory results showed a gain of 2.25 to 4.19 percentile rank points on standardized assessments across all subjects (State of Alabama Department of Education, 2012).

When comparing New York State's mathematics, ELA and science scores for the six most recent years ranging from 2005-2011, the percentage of students that scored at or above level 3 in science consistently outperformed mathematics and ELA. Mathematics and ELA scores have fluctuated over the years, whereas science scores are consistently exceptional. Table 7 displays the statewide performance of the three content areas over the past six years. Future research should be aimed at understanding why these discrepancies exist in New York elementary schools and the role of principals in these disciplines.

Furthermore, a mixed-methods approach is recommended for future research to better understand principals' influence in these domains. Incorporating observations and interviews of principals will provide a better understanding of their role. It is also highly recommended to attend one of the regularly scheduled monthly superintendent meetings in Albany to increase participation of New York principals across all school types. Gaining the support of district superintendents is likely to increase the participation of principals as well as determine the right time to implement research in busy schools.

Table 7.

2006 – 2011 New York Statewide Performance: Science, Math and ELA

Percentage of students that scored at or above level 3			
Year	Science	Mathematics	ELA
2010 - 2011	88	67	57
2009 - 2010	88	64	57
2008 – 2009	88	87	77
2007 - 2008	85	84	71
2006 - 2007	85	80	68
2005 - 2006	86	78	69

REFERENCES

- Abell, S., & Smith, D. (1994). What is science? Preservice elementary teachers' conceptions of the nature of science. *International Journal of Science Education*, 16, 475–487.
- American Association for the Advancement of Science. (1989). *Science for all Americans*. New York: Oxford University Press.
- American Association for the Advancement of Science. (1993). *Benchmarks for science literacy: Project 2061*. New York: Oxford University Press.
- Andre, T., Whigham, M., Hendrickson, A., & Chambers, S. (1999). Competency beliefs, positive attitudes, and gender stereotypes of elementary students and their parents about science versus other school subjects. *Journal of Research in Science Teaching*, 36(6), 719-147.
- Apelman, M. (1984). Critical barriers to the understanding of elementary science: Learning about light and color. In C. Anderson (Ed.), *Observing science classrooms: Observing science perspectives from research and practice*, AETS Yearbook (pp. 3–36). Columbus, OH: ERIC/SMEAC.
- Appleton, K. (2008). Developing science pedagogical content knowledge through mentoring elementary teachers. *Journal of Science Teacher Education*, 19, 523-545.
- Appleton, K., & Kindt, I. (2002). Beginning elementary teachers' development as teachers of science. *Journal of Science Teacher Education*, 13(1), 43-61.
- Baines, E., Blatchford, P., & Chowne, A. (2007). Improving the effectiveness of collaborative group work in primary schools: Effects on science attainment. *British Educational Research Journal*, 33(5), 663-680.
- Baker, B. D., Punswick, E., & Belt, C. (2010). School leadership stability, principal moves, and departures: Evidence from Missouri. *Educational Administration Quarterly*, 46(4), 523-557.
- Baldi, S., Jin, Y., Skemer, M., Green, P., & Herget, D. (2007). Highlights from PISA 2006: Performance of U.S. 15-year-old students in science and mathematics literacy in an international context. NCES 2008-016. *National Center for Education Statistics* (ERIC Document Reproduction Service No. ED 499184).
- Barron, R. M., & Kenny, D. A. (1986). The moderator-mediator variable distinction in social psychological research: Conceptual, strategic, and statistical Considerations. *Journal of Personality and Social Psychology*, 51, 1173-1182.

- Barth, R. (1986). Principal centered professional development. *Theory Into Practice*, 25, 156-160.
- Barth, R. (1990). *Improving schools from within*. San Francisco: Jossey-Bass.
- Blase, J., & Blase, J. (1999). Principals' instructional leadership and teacher development: Teacher perspectives. *Educational Administration Quarterly*, 35, 349-378.
- Blasé, J., & Kirby, P. (2000). *Bringing out the best in teachers. What effective principals Do*. Thousand Oaks, CA: Corwin Press.
- Blossfeld, H. P., & Shavit, Y. (1993). Persisting barriers: Changes in educational opportunities in thirteen countries. In Y. Shavit & H. P. Blossfeld (Eds.), *Persistent inequality* (pp. 1-24). Boulder, CO: Westview.
- Blumberg, A. (1984). *The craft of school administration and some other rambling thoughts*. *Educational Administration Quarterly*, 20(4), 24-40.
- Bossert, S., Dwyer, D., Rowan, B., & Lee, G. (1982). The instructional management role of the principal. *Educational Administration Quarterly*, 18(3), 34-64.
- Bottoms, G., & O'Neill, K. (2001). *Preparing a new breed of principals: It's time for action*. Atlanta, GA: Southern Regional Education Board.
- Boyan, N. (1988). Describing and explaining administrative behavior. In N. Boyan (Ed.), *Handbook of research in educational administration*. New York: Longman.
- Bransford, J., Brown, A., & Cocking, R. (2000). *How people learn: Brain, mind, experience, and school*. Washington, DC: National Academy Press.
- Bridges, E. (1982). Research on the school administrator: The state of the art, 1967-1980. *Educational Administration Quarterly*, 18, 12-33.
- Burch, P., & Spillane, J. P. (2001, April). *Subject matter and elementary school leadership: Leaders' thinking about mathematics and literacy in the context of their school reform initiatives*. Paper presented at the annual meeting of the American Educational Research Association, Seattle, WA.
- Burch, P., & Spillane, J. P. (2003). Elementary school leadership strategies and subject matter: Reforming mathematics and literacy instruction. *Elementary School Journal*, 103(5), 519- 535.

- Burgoon, J. N., Heddle, M. L., & Duran, E. (2011). Re-examining the similarities between teacher and student conceptions about physical science. *Journal of Science Teacher Education*, 22(2), 101-114.
- Bybee, R. W. (1993). Leadership, responsibility, and reform in science education. *Science Educator*, 2, 1-9.
- Bybee, R. W. (2007). Science teaching and international assessments. *The Science Teacher*, 74(8) 41-48.
- Calderhead, J. (1996). Teachers: Beliefs and knowledge. In D. Berliner, & R. Calfee (Eds.), *Handbook of educational psychology*, (pp. 709-725). New York: Macmillan Library Reference.
- Callahan, R. E. (1962). *Education and the cult of efficiency*. Chicago: University of Chicago Press.
- Callahan, R. E. (1966). *The superintendent of schools: A historical analysis*. Washington, DC, U. S. Office of Education, Department of Health, Education, and Welfare. (ERIC Document Reproduction Service No. RD 0104410).
- Camburn, E., Rowan, B., & Taylor, T. E. (2003). Distributed leadership in schools: The case of elementary schools adopting comprehensive school reform models. *Educational Evaluation and Policy Analysis*, 25, 347-373.
- Campbell, R. F., Fleming, T., Newell, L. T., & Bennion, J. W. (1987). *A history of thought and practice in educational administration*. New York: Teachers College Press.
- Carver, C. L. (2003, April). *Principals and mentors working together: A case of distributed expertise*. Paper presented at the annual meeting of the American Educational Research Association, Chicago, IL.
- Chance, P. L., & Anderson, R. B. (2003, April). *The principal's role in standards-based reform: Linking accountability to instructional improvement*. Paper presented at the annual meeting of the American Educational Research Association, Chicago, IL.
- Chang, C., & Barufaldi, J. P. (1999). The use of a problem-solving-based instructional model in initiating change in students' achievement and alternative frameworks. *International Journal of Science Education*, 21(4), 373-388.
- Clark, D., Martorell, P., & Rockoff, J. (2009). *School principals and school Performance*. Working Paper 38. Washington, DC: The Urban Institute.

- Clune, W. (1998). *Toward a theory of systemic reform: The case of nine NSF statewide Systemic initiatives*. Madison, WI: National Institute for Science Education.
- Cohen, E., & Miller, R. (1980). Coordination and control of instruction. *Pacific Sociological Review*, 23, 446-473.
- Cohen, J. (1988). *Statistical power analysis for the behavioral sciences* (2nd ed.). Hillsdale, NJ: Lawrence Erlbaum Associates.
- Cohen, J. (1992). A power primer. *Psychological Bulletin*, 112(1), 155-159.
- Cohen, J., Cohen, P., West, S. G., & Aiken, L. S. (2003). *Applied multiple regression/correlation analysis for the behavioural sciences* (3rd ed.). Mahwah, NJ: Erlbaum.
- Conderman, G. & Woods, C. S. (2008). Science instruction: An endangered species. *Kappa Delta Phi Record*, 44(2), 76.
- Copland, M. A. (1999). Problem-based learning, problem framing ability and the principal selves of prospective school principals (Administration). *Dissertation Abstracts International*, 60 (08) 2750A. (UMI No. 19943639).
- Cotton, K. (2003). *Principals and student achievement: What the research says*. Alexandria, VA: Association for Supervision and Curriculum Development.
- Council of Chief State School Officers. (2008). Interstate School Leaders Licensure Consortium. (2008). *Standards for School Leaders*. Retrieved March 3, 2010, from <http://www.ccsso.org>
- Couper, M. P., Traugott, M., & Lamias, M. (2001). Web survey design and administration. *Public Opinion Quarterly*, 65, 230-235.
- Crawford, S., Couper, M., & Lamias, M. (2001). Web surveys: Perceptions of burden. *Social Science Computer Review*, 19(2), 146-162.
- Cronin-Jones, J. J. (1991). Science teacher beliefs and their influence on curriculum implementation: Two case studies. *Journal of Research in Science Teaching*, 28, 235-250.
- Crow, G. M., Hausman, C. S., & Scribner, J. P. (2002). Reshaping the role of the school principal. In J. Murphy (Ed.), *The educational leadership challenge: Redefining leadership for the 21st century: 101st yearbook of the National Society for the Study of Education* (Vol. 101, Pt. 1, pp. 189-210). Chicago: University of Chicago Press.

- Crowson, R. L., & McPherson, R. B. (1987). The legacy of the theory movement: Learning from the new tradition. In J. Murphy & P. Hallinger (eds.), *Approaches to administrative training in education* (pp. 3-27). Albany: State University of New York Press.
- Culberston, J. A. (1965). Trends and issues in the development of a science of administration. In Center for the Advanced Study of Educational Administration (Ed.), *Perspectives on educational administration and the behavioral sciences* (pp. 3-22). Eugene, OR: University of Oregon.
- Culbertson, J. A. (1988). A century's quest for a knowledge base. In N. Boyan (Ed.), *Handbook of research in educational administration* (pp. 3-36). White Plains, New York: Longman.
- Daly, A. J. (2009). Rigid response in an age of accountability: The potential of leadership and trust. *Educational Administration Quarterly*, 45(2), 168-216.
- Darling-Hammond, L. (1997). *Doing what matters most: Investing in quality teaching*. New York: National Committee on Teaching and America's Future.
- Donmoyer, R. (1999). The continuing quest for a knowledge base: 1976-1998. In J. Murphy & K. S. Lewis (Eds.), *Handbook of research on educational administration* (2nd ed., pp. 25-43). San Francisco: Jossey-Bass.
- Driver, R., Asoko, H., Leach, J., Mortimer, E., & Scott, P. (1994). Constructing scientific knowledge in the classroom. *Educational Researcher*, 23, 5-12.
- Driver, R., Guesne, E., & Tiberghien, A. (1985). *Children's ideas in science*, Philadelphia: Open University Press.
- Edwards, A. (1957). *Techniques for attitude scale construction*. New York: Appleton-Century-Crofts.
- Elmore R. F. (1979) Backward mapping: Implementation research and policy decisions. *Political Science Quarterly*, 94(4), 601-616.
- Elmore, R. F. (2000). *Building a new structure for school leadership*. Washington, DC: Albert Shanker.
- Elmore, R. F. (2004). *School reform from the inside out: Policy, practice, and performance*. Cambridge, MA: Harvard Education Press.
- Elmore, R., Abelman, C., & Fuhrman, S. (1996). The new accountability in state education reform: From process to performance. In H. Ladd (Ed.), *Holding schools accountable: Performance-based reform in education* (pp. 65-98). Washington, DC: Brookings.

- English, F. W. (2006). The unintended consequences of a standardized knowledge base in advancing educational leadership preparation. *Educational Administration Quarterly*, 42(3), 461-472.
- Evans, A. E. (2007). School leaders and their sense making about race and demographic change. *Educational Administration Quarterly*, 43(2), 159-188.
- Everhart, R. (1988). Fieldwork methodology in educational administration. In N. Boyan (Ed.) *The handbook of research on educational administration*. New York: Longman.
- Farkas, S., Johnson, J., Duffett, A., & Foleno, T. (2001). *Trying to stay ahead of the game: Superintendents and principals talk about school leadership*. New York: Public Agenda.
- Firestone, W. (2009). Accountability nudges districts into changes in culture. *Phi Delta Kappan*, 90, 670-676.
- Firestone, W. A. & Riehl, C. (2005). *A new agenda: Directions for research on educational leadership*. New York: Teachers College Press.
- Firestone, W. A., & Wilson, B. L. (1985). Using bureaucratic and cultural linkages to improve instruction: The principal's contribution. *Educational Administration Quarterly*, 21(2), 7-30.
- Fowler, F. J. (2002). *Survey research designs*. Thousand Oaks, California: Sage Publications.
- Fowler, R. (1994, April). *Piagetian versus Vygotskian perspectives on development and education*. Paper presented at the annual meeting of the American Educational Research Association, Chicago, IL.
- Frazier, P. A., Tix, A. P., & Barron, K. E. (2004). Testing moderator and mediator effects in counseling psychology. *Journal of Counseling Psychology*, 51(1), 115-134.
- Frick, A., Bachtiger, M. T., & Reips, U. D. (1999). Financial incentives, personal information and drop-out rates in online studies. *Current Internet Science*. Retrieved March 22, 2010, from http://www.psychologie.unizh.ch/sowi/reips/books/tband99/pdfs/a_h/frick.pdf.
- Fullan, M. (2003). *The moral imperative of school leadership*. Thousand Oaks, CA: Corwin Press.
- Fullan, M., & Miles, M. (1992). Getting reform right: What works and what doesn't. *Phi Delta Kappan*, 73(10), 744-752.

- Geier, R., Blumenfeld, P., Marx, R., Krajcik, J., Fishman, B., Soloway, E., et al. (2008). Standardized test outcomes for students engaged in inquiry-based science curricula in the context of urban reform. *Journal of Research in Science Teaching*, 45(8), 922-939.
- Gentilucci, J. L., & Muto, C. C. (2007). Principals' influence on academic achievement: The student perspective. *NASSP Bulletin*, 9(3), 219-236.
- Getzels, J. W. (1977). Educational administration twenty years later, 1954-1974. In L. Cunningham, W. Hack, & R. Nystrand (Eds.), *Educational administration: The developing decades* (pp. 3-24). Berkeley, CA: McCutchan.
- Glasman, N. (1984). Student achievement and the school principal. *Educational Evaluation and Policy Analysis*, 6, 283-296.
- Glickman, C. D. (1992). *Supervision in transition*. Alexandria, VA: ASCD.
- Glickman, C. (1989). Has Sam and Samantha's time come at last? *Educational Leadership*, 46(8), 4-9.
- Goddard, R. D., Sweetland, S. R., & Hoy, W. K. (2000). Academic emphasis of urban elementary schools and student achievement in reading and mathematics: A multilevel analysis. *Educational Administration Quarterly*, 36(5), 683-702.
- Goldhammer, K. (1983). Evolution in the profession. *Educational Administration Quarterly*, 19(3), 249-272.
- Gonzales, P., Williams, T., Jocelyn, L., Roey, S., Kastberg, D., & Brenwald, S. (2008). *Highlights from TIMSS 2007. Mathematics and science achievement of U.S. fourth and eighth-grade students in an international context*. Washington, DC: IES, NCES.
- Grogan, M., & Andrews, R. (2002). Defining preparation and professional development for the future. *Educational Administration Quarterly*, 38(2), 233-256.
- Groves, R. M., Cialdini, R. B., & Couper, M. P. (1992). Understanding the decision to participate in a survey. *Public Opinion Quarterly*, 56, 475-95.
- Hale, E. L. & Moorman, H. N. (2003). *Preparing school principals: A national perspective on policy and program innovations*. Institute for Educational Leadership, Washington, DC and Illinois Education Research Council, Edwardsville, IL.
- Hallinger, P. (1992). The evolving role of American principals: From managerial to instructional to transformational leaders. *Journal of Educational Administration*, 30(3), 35-48.

- Hallinger, P. (2003). Leading educational change: Reflections on the practice of instructional and transformational leadership. *Cambridge Journal of Education*, 33(3), 329-351.
- Hallinger, P. (2007). *Leadership for learning*. Presentation at the annual conference of the Australian Council for Educational Research, Melbourne, Australia. Retrieved April 23, 2009 from www.acer.edu.au/documents/RC2007_Hallinger-Presentation.pdf
- Hallinger, P. (2008, March). *Methodologies for studying school leadership: A review of 25 years of research using the principal instructional management rating scale (Version 4.7, May 14, 2008)*. Paper prepared for presentation at the annual meeting of the American Educational Research Association, New York.
- Hallinger, P. (2011). A review of three decades of doctoral studies using the principal instructional management rating scale: A lens on methodological progress in educational leadership. *Educational Administration Quarterly*, 47(2), 271-306.
- Hallinger, P., Bickman, L., & Davis, K. (1996). School context, principal leadership, and student reading achievement. *The Elementary School Journal*, 96(5), 527-549.
- Hallinger, P. & Heck, R. (1996a). The principal's role in school effectiveness: An assessment of methodological progress, 1980-1995. In K. Leithwood, J. Chapman, P. Corson, P. Hallinger, & A. Hart. (Eds.), *International handbook of research in educational leadership and administration* (pp. 723-784). New York, NY: Kluwer.
- Hallinger, P. & Heck, R. (1996b) Reassessing the principal's role in school effectiveness: A review of empirical research, 1980-1995, *Educational Administration Quarterly*, 32(1), pp. 5- 44.
- Hallinger, P. & Heck, R. H. (1998) Exploring the principal's contribution to school effectiveness: 1980-1995. *School Effectiveness and School Improvement*, 9, 157-191.
- Hallinger, P., & Heck, R. H. (2005). The study of educational leadership and management: Where does the field stand today? *Educational Management Administration and Leadership*, 33(2), 229-244.
- Hallinger, P., & Leithwood, K. (1998). Unseen forces: The impact of social culture on school leadership. *Peabody Journal of Education*, 73(2), 126-151.
- Hallinger, P., & McCary, C. E. (1990). Developing the strategic thinking of instructional leaders. *The Elementary School Journal*, 91(2), 89-108.

- Hallinger, P., & Murphy, J. (1985a). Characteristics of highly effective elementary school reading programs. *Educational Leadership*, 52(5), 39-42.
- Hallinger, P., & Murphy, J. (1985b). Assessing the instructional management behavior of principals. *Elementary School Journal*, 86(2), 217-247.
- Hallinger, P., & Murphy, J. (1986a). Instructional leadership in school contexts. In W. Greenfield (Ed.), *Instructional leadership: Concepts, issues, and controversies*. Lexington, MA: Allyn & Bacon.
- Hallinger, P., & Murphy, J. (1986b). The social context of effective schools. *American Journal of Education*, 94, 328-355.
- Hallinger, P., & Murphy, J. (1987a). Assessing and developing principal instructional leadership. *Educational Leadership*, 45(1), 54-61.
- Hallinger, P., & Murphy, J. (1987b). Instructional leadership in the school context. In W. Greenfield (Ed.), *Instructional leadership: Concepts, issues, and controversies* (pp.179-203). Boston: Allyn & Bacon.
- Hallinger, P., Murphy, J., Weil, M., Mesa, R., & Mitman, A. (1983). Effective schools: The specific policies and practices of the principal. *National Association of Secondary School Principals Bulletin*, 67, 83-91.
- Halloun, I. A., & Hestenes, D. (1985). The initial knowledge state of college physics students. *American Journal of Physics*, 53(11), 1043-1048.
- Hardy, L. (2005). We have seen the future, and it isn't all we hoped. *The American School Board Journal*, 2-5.
- Harlen, W. (1997). Primary teachers' understanding in science and its impacts in the classroom. *Research in Science Education*, 27(3), 323-337.
- Harlen, W. (2000). *The teaching of science in primary schools*. David Fulton Publishers: London.
- Harlen, W., & Holroyd, C. (1997). Primary teachers' understanding of concepts of science: Impact on confidence and teaching. *International Journal of Science Education*, 19, 93-105.
- Heck, R. H. (1992). Principals instructional leadership and school performance: Implications for policy development. *Educational Evaluation and Policy Analysis*, 14(1), 21-34.

- Heck, R., & Marcoulides, G. (1989). Examining the generalizability of administrative allocation decisions. *The Urban Review*, 21(1), 51-62.
- Heller, P. M. & Finley, F. N. (1992). Variable uses of alternative conceptions: A case study in current electricity. *Journal of Research in Science Teaching*, 29(3), 259-275.
- Hess, F.M. (2003). *High stakes accountability in the states in no child left behind? The politics and practice of accountability*. Brookings Institute Press. Washington, D.C.
- Hess, F. M., & Kelly, A. P. (2007). Learning to lead: What gets taught in principal-preparation programs. *Teachers College Record*, 109(1), 1-28.
- Hightower, A. M., Knapp, M. S., Marsh, J. A., & McLaughlin, M. W. (Eds.). (2002). *School districts and instructional renewal*. New York, NY: Teachers College Press.
- Hoy, W. K., Tarter, C. J., & Hoy, A. W. (2006). Academic optimism of schools: A force for student achievement. *American Educational Research Journal*, 43(3), 425-446.
- Institute for Educational Leadership. (2000). *Leadership for student learning: Reinventing the principalship*. Retrieved January 23, 2010, from www.iel.org/programs/21st/reports/principal.pdf
- Iwanicki, E. F. (1999). ISLLC standards and assessment in the context of school leadership reform. *Journal of Personnel Evaluation in Education*, 13(3), 283-294.
- Jeynes, W. H. (2003). The effects of religious commitment on the academic achievement of urban and other children. *Education and Urban Society*, 36(1), 44-62.
- Johnson, B. & Christensen, L. (2010). *Educational research: Quantitative, qualitative, mixed approaches* (4th ed.). Thousand Oaks, California: Sage Publications Inc.
- Johnson, C. C., Kahle, J. B., & Fargo, J. D. (2006). A study of the effect of sustained, whole-school professional development on student achievement in science. *Journal of Research in Science Teaching*, 44(6), 775-786.
- Johnson, P. E., & Chrispeel, J. H. (2010). Linking the central office and its schools for reform. *Educational Administration Quarterly*, 46(5), 738-775.
- Joram, E., & Gabriele, A. (1998). Preservice teachers' prior beliefs: Transforming obstacles into opportunities. *Teaching and Teacher Education*, 14(2), 175-191.

- Kaplan, L.S., Owings, W.A., & Nunnery, J. (2005). Principal quality: A Virginia study connecting interstate school leaders licensure consortium standards with student achievement. *NASSP Bulletin*, 89(643), 28-44.
- Kiesler, S., & Sproull, L. S. (1986). Response effects in the electronic survey. *Public Opinion Quarterly*, 50, 402-413.
- Kowalski, T. (2009). Need to address evidence-based practice in educational administration. *Educational Administration Quarterly*, 45(3), 351-374.
- Kruger, C. J., Summers, M. K., & Palacio, D. J. (1990). An investigation of some english primary school teachers' understanding of the concepts force and gravity. *British Educational Research Journal*, 16(4), 383-397.
- Lawrenz, F. (1986). Misconceptions of physical science concepts among elementary school teachers. *School Science and Mathematics*, 86(8), 654-660.
- Lara-Alecio, R., Tong, F., Irby, B. J., Guerrero, C., Huerta, M., & Fan, Y. (2012). The effect of an instructional intervention on middle school English learners' science and English reading achievement. *Journal of Research in Science Teaching*, 49(8), 987-1011.
- Lee, C. A., & Houseal, A. (2003). Self-efficacy, standards, and benchmarks as factors in teaching elementary school science. *Journal of Elementary Science Education*, 15(1), 37-55.
- Lee, O., Buxton, C., Lewis, S., & LeRoy, K. (2006). Science inquiry and student diversity: Enhanced abilities and continuing difficulties after an instructional intervention. *Journal of Research in Science Teaching*, 43(7), 607-636.
- Leech, N. L., Barrett, K. C., & Morgan, G. A. (2008). *SPSS for intermediate statistics: Use and interpretation*. New York, NY: Taylor & Francis Group, LLC.
- Leiberman, A., & Miller, L. (1990). Restructuring schools: What matters and what works. *Phi Delta Kappan*, 71(10), 759-764.
- Leithwood, K. A. (1981). Managing the implementation of curriculum innovations. *Knowledge: Creation, Diffusion, Utilization*, 2(3), 341-360.
- Leithwood, K. (1994). Leadership for school restructuring. *Educational Administration Quarterly*, 30(4), 498-518.
- Leithwood, K. (1995). Cognitive perspectives on leadership. *Journal of School Leadership*, 5, 115-135.

- Leithwood, K., Begley, P. & Cousins, B. (1990). The nature, causes and consequences of principals' practices: Agenda for future research. *Journal of Educational Administration*, 28(4), 5-31.
- Leithwood, K., Begley, P. & Cousins, B. (1992). *Developing expert leaders for future schools*. Bristol, OA: Falmer.
- Leithwood, K., & Jantzi, D. (1990). Transformational leadership: How principals can help reform school cultures. *School Effectiveness and School Improvement*, 1(4), 249-280.
- Leithwood, K., & Jantzi, D. (2000). The effects of direct sources of leadership on student engagement in school. In L. Riley & K. Louis (Eds.), *Leadership for change and social reform* (pp. 50-66). London: Routledge.
- Leithwood, K., Jantzi, D., & Steinbach, R. (1999). *Changing leadership for changing times*. Philadelphia: Open University Press.
- Leithwood, K., Louis, K. S., Anderson, S., & Wahlstrom, K. (2004). *How leadership influences student learning: A review of research from the Leadership Project*. New York: Wallace Foundation.
- Leithwood, K., & Mascall, B. (2008). Collective leadership effects on student achievement. *Educational Administration Quarterly*, 44(4), 529-561.
- Leithwood, K. A., & Montgomery, D. J. (1982). The role of the elementary school principal in program improvement. *Review of Educational Research*, 52(3), 309-339.
- Levene, H. (1960). Contributions to Probability and Statistics. In I. Olkin (Ed.), *Essays in honor of Harold Hotelling* (pp. 278-292). Palo Alto, CA: Stanford University Press.
- Levin, H. M. (2005). Can research improve educational leadership? *Educational Researcher*, 35(8), 38-43.
- Lippman, L., Burns, S., & McArthur, E. (1996). *Urban schools: The challenge of location and poverty*. NCEES 96-184, Washington, DC: National Center for Education Statistics, U.S. Department of Education.
- Marks, H. M., & Printy, S. M. (2003). Principal leadership and school performance: integration of transformational and instructional leadership. *Educational Administration Quarterly*, 39(3), 370-397.

- Marx, R. W. & Harris, C. J. (2006). No child left behind and science education: Opportunities, challenges, and risks. *The Elementary School Journal*, 106(5), 467-477.
- Marshall, C., & McCarthy, M. (2002). School leadership reforms: Filtering social justice through dominant discourse. *Journal of School Leadership*, 12(5), 480-502.
- Matthews, M. R. (2002). Constructivism and science education: A further appraisal. *Journal of Science Education and Technology*, 11(2), 121-134.
- McDermott, L. C. (1989). A perspective on teacher preparation in physics and other sciences: The need for special science courses for teachers. *American Journal of Physics*, 58(8), 734- 742.
- McGhee, M. W. & Lew, C. (2007). Leadership and writing: How principals' knowledge, beliefs, and interventions affect writing instruction in elementary and secondary schools. *Educational Administration Quarterly*, 43(3), 358-380.
- McLeod, S., D'Amico, J., & Protheroe, N. (2003). *K-12 principals' guide to no child left behind*. Arlington, VA: Educational Research Service.
- Mechling, K. and Oliver, D. (1983). Who is killing your science program? *Science and Children*, 21(2), 15-18.
- Mehta, R., & Sivadas, E. (1995). Comparing response rates and response content in mail versus electronic surveys. *Journal of the Market Research Society*, 17(4), 429-440.
- Milam, A. J., Furr-Holden, C. D. M., & Leaf, P. J. (2010). Perceived school and neighborhood safety, neighborhood violence and academic achievement in urban school children. *Urban Review*, 42(5), 458-467.
- Minner, D. D., Levy, A. J., & Century, J. (2010). Inquiry-based science instruction-What is it and does it matter? Results from a research synthesis years 1984-2002. *Journal of Research in Science Teaching*, 47(4), 474-496.
- Mullholland, J., & Wallace, J. (2005). Growing the tree of teacher knowledge: Ten years of learning to teach elementary science. *Journal of Research in Science Teaching*, 42(7), 767-790.
- Murphy, J. (1988). Methodological, measurement, and conceptual problems in the study of instructional leadership. *Educational Evaluation and Policy Analysis*, 10(2), 117-139.

- Murphy, J. (1990). Principal instructional leadership. In R. S. Lotto & P. W. Thurston (Eds.), *Advances in educational administration: Changing perspectives on the school* (Vol. 1, Pt. B, pp. 163-200). Greenwich, CT: JAI.
- Murphy, J. (1992). *The landscape of leadership preparation: Reframing the education of school administrators*. Newbury Park, California: Corwin Press Inc.
- Murphy, J. (1995). The knowledge base in school administration: Historical footings and emerging trends. In R. Donmoyer, M. Imber, & J. J. Scheurich (Eds.), *The knowledge base in educational administration: Multiple perspectives* (pp. 62-73). Albany: State University of New York Press.
- Murphy, J. (2002). Reculturing the profession of educational leadership: New blueprints. *Educational Administration Quarterly*, 38(2), 176-191.
- Murphy, J. (2005). *Connecting teacher leadership and school improvement*. Thousand Oaks, CA: Corwin Press.
- Murphy, J., & Hallinger, P. (1985). Effective high schools: What are the common characteristics? *NASSP Bulletin*, 69(477), 18-22.
- Murphy, J., Hallinger, P., & Mitman, A. (1983). Research on educational leadership: Issues to be addressed. *Educational Evaluation and Policy Analysis*, 5(3), 297-305.
- Murphy, J., & Shipman, N. J. (1999). The interstate school leaders licensure consortium: A standards-based approach to strengthening educational leadership. *Journal of Personnel Evaluation in Education*, 13(3), 205-224.
- National Association of Elementary & Secondary Principals (2008). *Leading learning communities: Standards for what principals should know and be able to do*. Alexandria, Virginia: Author.
- National Center for Education Statistics (2011a). The nation's report card. Retrieved December 17, 2011, from <http://nces.ed.gov/nationsreportcard/pubs/main2009/2011451.asp>
- National Commission for Excellence in Education. (1983). *A nation at risk: The imperative for educational reform*. Washington, DC: Government Printing Office.
- National Institute of Child Health and Human Development - Early Child Care Research Network. (2005). A day in third grade: A large-scale study of classroom quality and teacher and student behavior. *Elementary School Journal*, 105, 305-323.

- National Policy Board for Educational Administration. (2002). *Standards for advanced programs in educational leadership*. Arlington, VA: National Council of Professors of Educational Administration.
- National Research Council. (1996). *National science education standards*. Washington, DC: National Academy Press.
- National Research Council. (2002). *Learning and understanding: Improving advanced study of mathematics and science in U.S. high schools*. Washington, DC: National Academy Press.
- National Research Council (2011). *A framework for k-12 science education: Practices, crosscutting, concepts, and core ideas*. Washington, DC: National Academy Press.
- National Science Foundation (NSF). (1996). *The learning curve: What we are discovering about U.S. science and mathematics education*. Washington, D.C.: NSF.
- National Staff Development Council. (2000). *Learning to lead, leading to learn: Improving school quality through principal professional development*. Oxford, OH.
- New York City Department of Education (2010). School portals. Retrieved March 6, 2010, from <http://schools.nyc.gov/NR/exeres/7ED625FD-7BCE-441B-A25D-29D8654EC47D.htm>
- New York State Education Department. (2010a). Glossary of statistics for public school districts. Retrieved February 11, 2010, from www.p12.nysed.gov/irs/chapter655/2001/V2_glossary_2001.pdf
- New York State Education Department (2010b). Report card home. Retrieved June 11, 2010, from <https://reportcards.nysed.gov/schools.php?district=all&year=2009>
- New York State Education Department. (2010c). Grade 4 elementary level science test conversion chart. Retrieved June 11, 2010, from <http://www.nysedregents.org/Grade4/Science/home.html>
- New York State Education Department. (2010d). Grade 4 elementary level science test rating guide. Retrieved June 11, 2010, from <http://www.nysedregents.org/Grade4/Science/home.html>
- New York State Education Department (2010e). 2008-2009 New York statewide report card. Retrieved June 11, 2010, from <https://reportcards.nysed.gov/view.php?county=yes&year=2009>

- No Child Left Behind Act of 2001, Public Law No. 107-110.
- O'Sullivan, C., Lauko, M., Grigg, W., Qian, J., & Zang, J. (2003, January). *The nation's report card: Science 2003*. NCES 2003-453. Washington, DC: U.S. Department of Education, Institute of Education Sciences, National Center for Education Statistics.
- Ogawa, R. T., & Hart, A. W. (1985). The effects of principals on the instructional performance of schools. *The Journal of Educational Research*, 23(1), 59-72.
- Orfield, G., Kim, J., Sunderman, G., & Greer, B. (2004). *No Child Left Behind: A federal, state, and district level look at the first year*. Civil Rights Project, Harvard University.
- Organization for Economic Cooperation and Development (2011). Program for international student assessment. Retrieved December 21, 2011 from www.oecd.org/edu/pisa/2009
- Orr, M. T., & Orphanos, S. (2011). How graduate-level preparation influences the effectiveness of school leaders: A comparison of the outcomes of exemplary and conventional leadership preparation programs for principals. *Educational Administration Quarterly*, 47(1), 18-70.
- Pajares. M. F. (1992). Teachers' beliefs and educational research: Cleaning up a messy construct. *Review of Educational Research*, 62, 307-332.
- Parkinson, P. (2009). Political economy and the NCLB regime: Accountability, standards, and high-stakes testing. *The Educational Forum*, 73, 44-57.
- Partlow, M. C. (2007). Contextual factors related to elementary principal turnover. *Planning and Changing*, 38(1), 60-76.
- Phillips, D. (1997). How, why, what, when, and where: Perspectives on constructivism in psychology and education. *Issues in Education*, 3, 151-194.
- Pink, W. (1984). Creating effective schools. *The Educational Forum*, 49(1), 91-107.
- Pitner, N. (1988). The study of administrator effects and effectiveness. In N. Boyan (Ed.), *Handbook of research in educational administration*. White Plains, NY: Longman.
- Plevyak, L. (2007). What do preservice teachers learn in an inquiry-based science methods course? *Journal of Elementary Science Education*, 19(1), 1-13
- Poole, W. (1995). *Reconstructing the teacher-administrator relationship to achieve systematic change*. (ERIC Document Reproduction Service, No. 384127)

- Printy, S. M. (2008). Leadership for teacher learning: A community of practice perspective. *Educational Administration Quarterly*, 44(2), 187-226.
- Reitzug, U. C., & Cross, B. (1993). *Deconstructing principal instructional leadership: From "super" vision to critical collaboration*. Paper presented at the annual conference of the University Council for Educational Administration, Houston, TX.
- Rhoton, J. (2001). School science reform: An overview and implications for the secondary school principal. *NASSP Bulletin*, 85(623), 10-23.
- Rice, R. C., & Islas, M. R. (2001). TIMSS and the influence of the instructional leader on mathematics and science instruction. *NASSP Bulletin*, 85(623), 5-9.
- Roach, V., Wes-Smith, L., & Boutin, J. (2011). School leadership policy trends and developments: Policy expediency or policy excellence? *Educational Administration Quarterly*, 47(1), 71-113.
- Robelen, E. W. (2009). Nuances of principalship explored. *Education Week*, 29(14), 1-2.
- Robinson, V. M. (2006). Putting education back into educational leadership. *Leading and Managing*, 12(1), 62-75.
- Robinson, V. M., Lloyd, C. A., & Rowe, K. J. (2008). The impact of leadership on student outcomes: An analysis of the differential effects of leadership types. *Educational Administration Quarterly*, 44(5), 635-674.
- Rowan, B., Dwyer, D., & Bossert, S. (1982). *Methodological considerations in the study of effective principals*. Paper presented at the Annual Meeting of the American Research Association, New York.
- Ruby, A. (2006). Improving science achievement at high-poverty urban middle schools. *Science Education*, 90(6), 1005-1027.
- Ruff, W. G., & Shoho, A. R. (2005). Understanding instructional leadership through the mental models of three elementary school principals. *Educational Administration Quarterly*, 41(3), 554-577.
- Rumberger, R., & Palardy, G. (2005). Does segregation still matter? The impact of student composition on academic achievement in high school. *Teachers College Record*, 107, 1999-2045.
- Sadler, P., & Cook-Smith, N. (2011, January). *MOSART: Misconceptions oriented standards-based assessment resource for teachers*. Conference paper presented at 2011 MSP Learning Network Conference.

- Sampson, V. & Benton, A. (2006, January). *Development and validation of the Beliefs About Reformed Science Teaching and Learning (BARSTL) questionnaire*. Paper presented at the Annual Conference of the Association of Science Teacher Education (ASTE). Portland, OR.
- Sanders, L. R., Borko, H., & Lockard, J. D. (1993). Secondary science teachers' knowledge base when teaching science courses in and out of their area of certification. *Journal of Research in Science Teaching*, 30, 723-736.
- Sarason, S. B. (2002). *Educational reform: A self-scrutinizing memoir*. New York: Teachers College Press.
- Sax, L. J., Gilmartin, S. K., & Bryant, A. N. (2003). Assessing response rates and nonresponse bias in web and paper surveys. *Research in Higher Education*, 44(4), 409-432.
- Scheurich, J. J. (1995). The knowledge base in educational administration: Postpositive Reflections. In R. Donmoyer, M. Imber, & J. J. Scheurich (Eds.), *The knowledge base in educational administration: Multiple perspectives* (pp. 17-31). Albany: State University of New York Press.
- Schwartz, R. S., Lederman, N. G., & Abd-El-Khalick, F. (2000). Achieving the reforms vision: The effectiveness of a specialists-led elementary science program. *School Science and Mathematics*, 100(4), 181-193.
- Sergiovanni, T. J. (1991). *Value-added Leadership: How to get extraordinary performance in Schools*. New York: Harcourt Brace Jonvanovich.
- Sheehan, K. (2001). E-mail survey response rates: A review. *Journal of Computer Mediated Communication*, 6(2).
- Sheehan, K. B., & Hoy, M. B. (1999). Using e-mail to survey internet users in the United States: Methodology and assessment. *Journal of Computer Mediated Communication*, 4(3). Retrieved March 31, 2010 from <http://jcmc.indiana.edu/vol4/issue3/sheehan.html>
- Sheehan, K. B., & McMillan, S. J. (1999). Response variation in e-mail surveys: An exploration. *Journal of Advertising Research*, 39(4), 45-54.
- Showers, B., & Joyce, B. (1996). The evolution of peer coaching. *Educational Leadership*, 53(6), 12-16.
- Shulman, L. S. (1986). Those who understand: Knowledge growth in teaching. *Educational Researcher*, 15(2), 4-14.

- Silver, P. F. (1982). Administrator preparation. In Mitzel Hem (Ed.), *Encyclopedia of educational research*, 5ed, (pp. 49-59). New York: Free Press.
- Sirin, S. R. (2005). Socioeconomic status and academic achievement: A meta-analytic review of research. *Review of Educational Research*, 75(3), 417-453.
- Smith, D. (1987). *Primary teachers' substantive, syntactic and pedagogical content knowledge*. Paper presented at the annual meeting of the National Association of Research in Science Teaching, Washington, DC.
- Smith, C. R., & Muth, R. (1985). *Instructional leadership and school effectiveness*. Paper presented at the annual meeting of the American Education Research Association. Chicago, IL.
- Smith, D. C., & Anderson, C. W. (1999). Appropriating scientific practices and discourses with future elementary teachers. *Journal of Research in Science Teaching*, 36(7), 755-776.
- Snyder, T. D. (2008). *Mini-Digest of Education Statistics, 2007* (NCES 2008-023). National Center for Education Statistics, Institute of Educational Sciences, U.S. Department of Education. Washington, D.C.
- Sparks, D., & Loucks-Horsley, S. (1990). Models of staff development. In Houston, W. R. (Ed.), *Handbook of research on teacher education* (pp. 234-250). New York: Macmillan.
- Spillane, J. (2005). Primary school leadership practice: How the subject matters. *School Leadership and Management*, 25(4), 383-397.
- Spillane, J. P., Diamond, J. B., Walker, L. J., Halverson, R., & Jita, L. (2001). Urban school leadership for elementary science instruction: Identifying and activating resources in an undervalued school subject. *Journal of Research in Science Teaching*, 38(8), 918-940.
- Spillane, J. P., Halverson, R., & Diamond, J. B. (2001). Investigating school leadership practice: A distributed perspective. *Educational Researcher*, 30(3), 23-28.
- Spillane, J. P., & Seashore-Louis, K. (2002). School improvement processes and practices: Professional learning for building instructional capacity. *Yearbook for the National Society for the Study of Education*, 101(1), 83-104.
- Spray, C. O (1969). Meaningful grade reporting. *The Clearing House*, 43(6), 338-341.
- State of Alabama Department of Education. (2012). *Five year, \$3 million study shows significant effectiveness of program*. Retrieved August 19, 2012 from <http://www.amsti.org/About/Evaluations/tabid/133/Default.aspx>

- Stein, M. K., & D'Amico, L. (2002). Inquiry at the crossroads of policy and learning: A study of a district-wide literacy initiative. *Teachers College Record*, 104, 1313-1344.
- Stein, M. K., & Nelson, B. S. (2003). Leadership content knowledge. *Educational Evaluation and Policy Analysis*, 25(4), 423-448.
- Stein, M., Larrabee, T.G., & Barman, C.R. (2008). A study of common beliefs and misconceptions in physical science. *Journal of Elementary Science Education*, 20(2), 1-11.
- Sunderman, G. L., Orfield, G., & Kim, J. S. (2006a). The principals denied by NCLB are central to visionary school reform. *The Education Digest*, 72(2), 19-24.
- Sunderman, G. L., Orfield, G., & Kim, J. S. (2006b). Flawed assumptions: How no child left behind fails principals. *Principal Leadership*, 6(8), 16-19.
- Sungur, S., & Tekkaya, C. (2006). Effects of problem-based learning and traditional instruction on self-regulated learning. *The Journal of Educational Research*, 99, 307-317.
- Teale, W. H., & Gambrell, L. B. (2007). Raising urban students' literacy achievement by engaging in authentic, challenging work. *The Reading Teacher*, 60(8), 728-739.
- Tilgner, P. J. (1990). Avoiding science in elementary school. *Science Education*, 74, 421-431.
- Timperley, H. S. (2006). Learning challenges involved in developing leading for Learning. *Educational Management Administration and Leadership*, 34, 546-563.
- Togneri, W., & Anderson, S. E. (2003). *Beyond islands of excellence: What districts can do to improve instruction and achievement in all schools*. Washington, DC: Learning First Alliance & Association for Supervision and Curriculum Development.
- Tse, A., Tse, K.C., Yin, C.H., Ting, C.B., Yi, K.W., Yee, K.P., & Hong, W.C. (1995). Comparing two methods of sending out questionnaires: E-mail versus mail. *Journal of the Market Research Society*, 37(4), 441-445.
- Tuten, T. L., Bosnjak, M., & Brandilla, W. (2000). Banner-advertised web-based surveys. *Marketing Research*, 11(4), 17-21.
- Tye, B. B. (2000). *Hard truths: Uncovering the deep structure of schooling*. New York: Teachers College Press.

- United States Department of Education, National Center for Education Statistics. (2000). *The Condition of Education 2000, NCES 2000-602*. Washington, DC: Government Printing Office.
- United States Department of Education. (2009). *MSP Performance period 2009 annual draft final report v2(3)*. Retrieved October 7, 2010, from <http://www.2.ed.gov/programs/mathsci/performance.html>
- Van Driel, J.H., Verloop, N., & de Vos, W. (1998). Developing science teachers' pedagogical content knowledge. *Journal of Research in Science Teaching*, 35(6), 673-695.
- Van Selm, M., & Jankowski, N. W. (2006). Conducting online surveys. *Quality & Quantity*, 40, 435-436.
- Victor, E., & Kellough, R. (2000). *Science for elementary and middle school*. Upper Saddle River, NJ: Prentice Hall.
- Von Glasersfeld. (1989). Cognition, construction of knowledge, and teaching. *Synthese*, 80(1), 121-140.
- Wahlstrom, K. L., & Seashore Louis, K. (2008). How teachers experience principal leadership: The roles of professional community, trust, efficacy, and shared responsibility. *Educational Administration Quarterly*, 44(4), 458-495.
- Waters, T., Marzano, R.J., & McNulty, B. (2003). *Balanced leadership: What 30 years of research tells us about the effect of leadership on student achievement*. Aurora, CO: Mid-Continent Research for Education and Learning (McREL).
- Weiss, I. R., Knapp, M. S., Hollweg, K. S., & Burrill, G. (2001). *Investigating the influence of standards: A framework for research in mathematics, science, and technology education*. Washington, DC: National Academies Press.
- Witziers, B., Bosker, R. J., Kruger, M. L. (2003). Educational leadership and student achievement: The elusive search for an association. *Educational Administration Quarterly*, 39(3), 398-425.
- Young, M. D., Petersen, G. J., & Short, P. M. (2002). The complexity of substantive reform: A call for interdependence among key stakeholders. *Educational Administration Quarterly*, 38(2), 137-175.
- Youngs, P. (2007). How elementary principals' beliefs and actions influence new teachers' experiences. *Educational Administration Quarterly*, 43(19), 101-137

Youngs, P., & King, M. B. (2002). Principal leadership for professional development to build school capacity. *Educational Administration Quarterly*, 38, 643-670.

APPENDIX A
Principal Survey

Principal Survey

Gender _____

Ethnicity _____

Total years experience as teacher ____

Subjects taught ____

Grades taught ____

Years principal at current school

Total years experience as principal

Degrees Held ____

Beliefs About Reformed Science Teaching and Learning

How People Learn About Science

The statements below describe different viewpoints concerning the ways students learn about science. Based on your beliefs about how people learn, indicate if you agree or disagree with each of the statements below using the following scale...

1: Strongly Disagree 2: Disagree 3: Agree 4: Strongly Agree

	SD	D	A	SA
1. Students develop many beliefs about how the world works before they ever study about science in school.	1	2	3	4
2. Students learn in a disorderly fashion; they create their own knowledge by modifying their existing ideas in an effort to make sense of new and past experiences.	1	2	3	4
3. People are either talented at science or they are not, therefore student achievement in science is a reflection of their natural abilities.	1	2	3	4
4. Students are more likely to understand a scientific concept if the teacher explains the concept in a way that is clear and easy to understand.	1	2	3	4
5. Frequently, students have difficulty learning scientific concepts in school because their beliefs about how the world works are often resistant to change.	1	2	3	4
6. Learning science is an orderly process; students learn by gradually accumulating more information about a topic over time.	1	2	3	4
7. Students know very little about science before they learn it in school.	1	2	3	4
8. Students learn the most when they are able to test, discuss, and debate many possible answers during activities that involve social interaction.	1	2	3	4

Lesson Design and Implementation

The statements below describe different ways science lessons can be designed and taught in school. Based on your opinion of how science should be taught, indicate if you agree or disagree with each of the statements below using the following scale...

1: Strongly Disagree 2: Disagree 3: Agree 4: Strongly Agree

	SD	D	A	SA
9. During a lesson, students should explore and conduct their own experiments with hands-on materials before the teacher discusses any scientific concepts with them	1	2	3	4
10. During a lesson, teachers should spend more time asking questions that trigger divergent ways of thinking than they do explaining the concept to students.	1	2	3	4
11. Whenever students conduct an experiment during a science lesson, the teacher should give step-by-step instructions for the students to follow in order to prevent confusion	1	2	3	4
12. Experiments should be included in lessons as a way to reinforce the scientific concepts students have already learned in class.	1	2	3	4
13. Lessons should be designed in a way that allows students to learn new concepts through inquiry instead of through a lecture, a reading or a demonstration.	1	2	3	4
14. During a lesson, students need to be given opportunities to test, debate and challenge ideas with their peers.	1	2	3	4
15. During a lesson, all of the students in the class should be encouraged to use the same approach for conducting an experiment or solving a problem.	1	2	3	4
16. Assessments in science classes should only be given after instruction is completed; that way the teacher can determine if the students have learned the material covered in class.	1	2	3	4

Characteristics of Teachers and the Learning Environment

The statements below describe different characteristics of teachers and classroom learning environments. Based on your opinion of what a good science teacher is like and what a classroom should be like, indicate if you agree or disagree with each of the statements below using the following scale...

1: Strongly Disagree 2: Disagree 3: Agree 4: Strongly Agree

	SD	D	A	SA
17. Students should do most of the talking in science classrooms.	1	2	3	4
18. Students should work independently as much as possible so they do not learn to rely on other students to do their work for them.	1	2	3	4
19. In science classrooms, students should be encouraged to challenge ideas while maintaining a climate of respect for what others have to say.	1	2	3	4
20. Teachers should allow students to help determine the direction and the focus of a lesson.	1	2	3	4
21. Students should be willing to accept the scientific ideas and theories presented to them during science class without question.	1	2	3	4
22. An excellent science teacher is someone who is really good at explaining complicated concepts clearly and simply so that everyone understands.	1	2	3	4
23. The teacher should motivate students to finish their work as quickly as possible.	1	2	3	4
24. Science teachers should primarily act as a resource person; working to support and enhance student investigations rather than explaining how things work.	1	2	3	4

The Nature of the Science Curriculum

The following statements describe different things that students can learn about in science while in school. Based on your opinion of what students should learn about during their science classes, indicate if you agree or disagree with each of the statements below using the following scale.

1: Strongly Disagree 2: Disagree 3: Agree 4: Strongly Agree

	SD	D	A	SA
25. A good science curriculum should focus on only a few scientific concepts a year, but in great detail.	1	2	3	4
26. The science curriculum should focus on the basic facts and skills of science that students will need to know later.	1	2	3	4
27. Students should know that scientific knowledge is discovered using the scientific method.	1	2	3	4
28. The science curriculum should encourage students to learn and value alternative modes of investigation or problem solving.	1	2	3	4
29. In order to prepare students for future classes, college, or a career in science the science curriculum should cover as many different topics as possible over the course of a school year.	1	2	3	4
30. The science curriculum should help students develop the reasoning skills and habits of mind necessary to do science.	1	2	3	4
31. Students should learn that all science is based on a single scientific method—a step- by-step procedure that begins with 'define the problem' and ends with 'reporting the results.'	1	2	3	4
32. A good science curriculum should focus on the history and nature of science and how science affects people and societies.	1	2	3	4

PHYSICAL SCIENCE TEST

For some questions, there may be more than one correct answer. However, each question has only one best answer. Choose the single best answer from the five choices for each question.

1. Each of the arrangements below includes a battery, light bulb, and wire. Which arrangement will light the bulb?

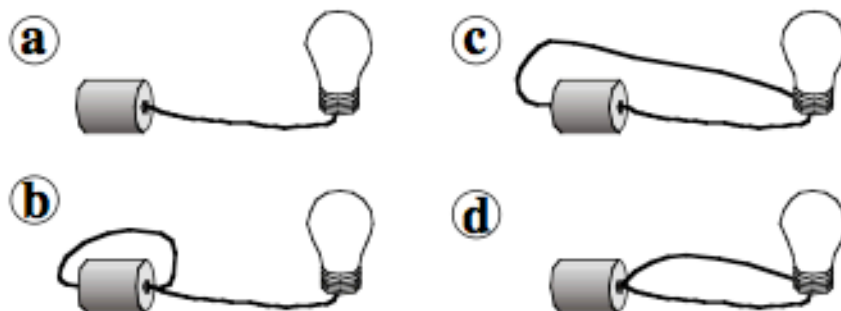

e More than one of the above.

2. A solid red block and a solid green block of the same size are placed in a container of water. The red block floats and the green block sinks. From this you know that:
- the two blocks are made of the same material.
 - the red block is heavier than the green block.
 - the green block is heavier than the red block.
 - the two blocks weigh the same.
 - You cannot say anything else about the blocks.
3. A metal pan of water is left on a counter. After a few days, there is less water in the pan. What most likely happened?
- Some water became part of the pan.
 - Movement of the air pulled water out of the pan.
 - Some water turned into oxygen and hydrogen.
 - Some water went into the air as a gas.
 - Some water no longer exists.

4. When a thrown baseball reaches the top of its path (see below), the main push or pull acting on it is:



- a. caused by Earth's magnetic field.
 - b. the force from the person throwing it.
 - c. due to Earth's rotation.
 - d. the pull of gravity.
 - e. No force is acting on the ball.
5. Look at the map below.

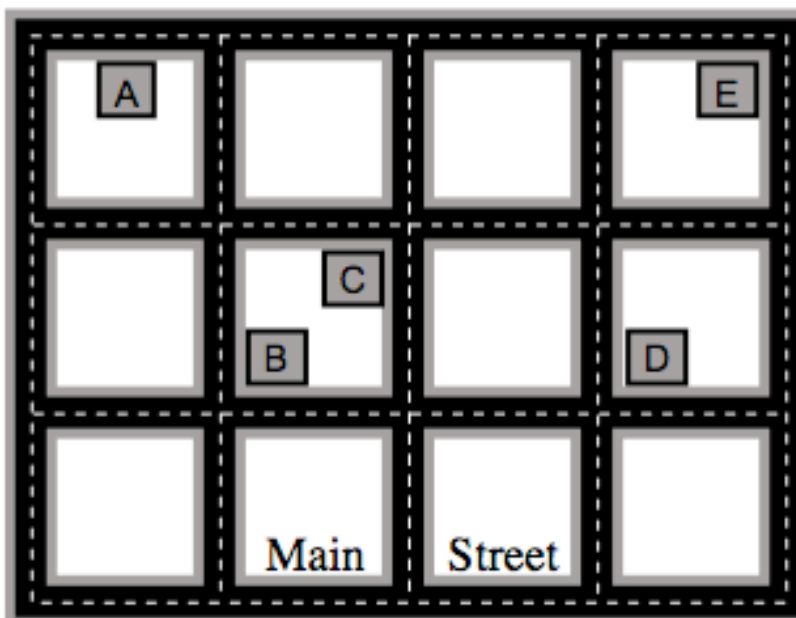

Which of the houses is located closest to House C along the streets?

- a. A
- b. B
- c. D
- d. E
- e. A and B

6. What is true about the source of any sound?
- A living thing had to be involved.
 - Something had to vibrate.
 - Air had to be involved.
 - More than one of the above.
 - None of the above.
7. Which of these tools is least like a ruler?
- A radio.
 - A clock.
 - A measuring cup.
 - A thermometer.
 - None of these is like a ruler.
8. Scientists say a metal doorknob indoors often feels cold to you because:
- cold from the doorknob goes into your hand.
 - heat from your hand goes into the doorknob.
 - cold moves from the doorknob to your hand.
 - heat is pulled from the doorknob by your hand.
 - metals are always colder than air.
9. Identical lights 1 and 2 are connected to the battery in the circuit below.

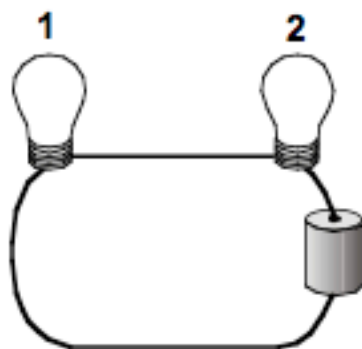

When connected as shown:

- light 1 is brighter than light 2.
- light 1 is dimmer than light 2.
- light 1 is the same brightness as light 2.
- one of the lights remains unlit and the other lights up.
- There is no way to tell if the lights' brightness would be the same or different.

10. On a hot day, Paul left a glass of ice water outside. After a while, the outside of the glass was wet because:
- the water in the glass seeped through the glass.
 - the ice in the glass became the water on the outside.
 - the water in the air became cooler and became liquid.
 - the ice in the glass melted and overflowed.
 - No one knows why the glass is wet.
11. Jon is walking on a path in a park. He slows down as he passes some flowers then resumes his normal pace. Which pattern of footprints below best represents John's footprints?

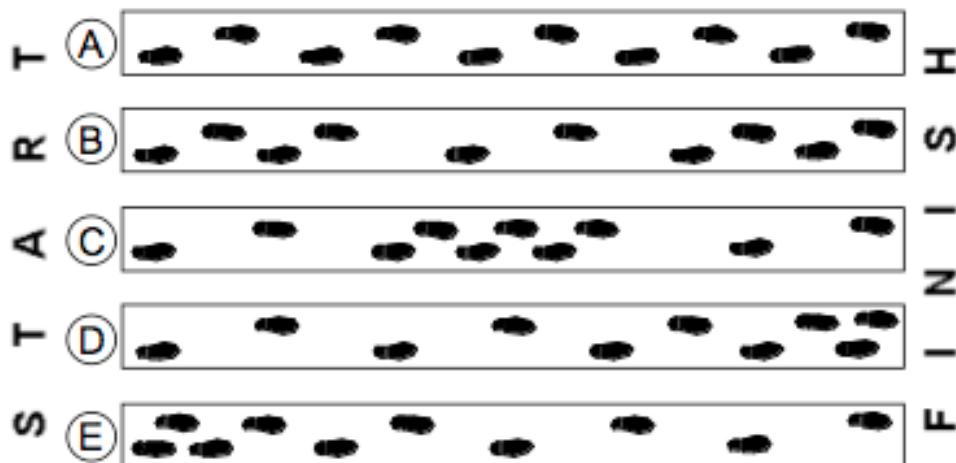

12. Michael made a low pitch sound on a horn (below) and wants to make a high pitch sound.



To make the high pitch sound, Michael must:

- a. cover more holes with his fingers.
 - b. blow into the horn with more force.
 - c. blow into the horn for a longer time.
 - d. make the air vibrate faster.
 - e. hold the horn more firmly.
13. If you cut a bar magnet in half, each half will:
- a. no longer attract objects.
 - b. attract from both ends.
 - c. attract objects only at one end.
 - d. have two north poles or two south poles.
 - e. be more powerful than the original.

14. Hot water in a sealed container is weighed on a scale.

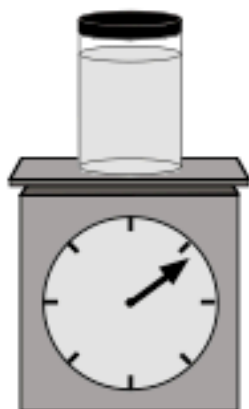

When the water cools to room temperature, the weight of the water:

- a. stays the same.
- b. will change.
- c. depends on how long it takes to cool.
- d. depends on its initial temperature.
- e. depends on the room temperature.

15. When you throw a rubber ball many times at the same spot on a wall, the ball bounces back farthest when you throw it:

- a. faster than the other times.
- b. slower than the other times.
- c. at the same speed every time.
- d. The speed you throw the ball does not matter.
- e. It depends upon how close you are to the wall.

16. If you place a drinking straw in a glass filled halfway with water, the straw looks like it is in two pieces (see picture). This is because water:



- a. changes the direction of light off the straw.
- b. reflects some light back into the straw
- c. increases the amount of light off the straw.
- d. actually bends the straw.
- e. dissolves light off the straw.

17. The first stack of bricks (stack 1) below is four times taller than the second stack (stack 2).

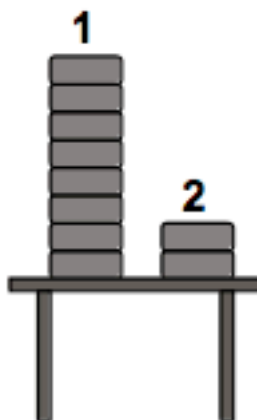

Which stack is being pushed on harder by the table?

- The table pushes harder on stack 1 than stack 2.
 - The table pushes equally on both stacks.
 - The table does not push on either stack.
 - The table pushes harder on stack 2 than stack 1.
 - It depends upon how closely the bricks are packed.
18. A clean brass rod is made mostly of two metals, copper and zinc. If you cut the rod in half and looked at a newly-cut end, it will look like:
- the brass outside.
 - bits of copper and bits of zinc.
 - copper.
 - zinc.
 - None of the above.
19. A balance is a tool used to directly measure:
- momentum
 - wright
 - density
 - volume
 - specific gravity

20. Look at the six objects below.

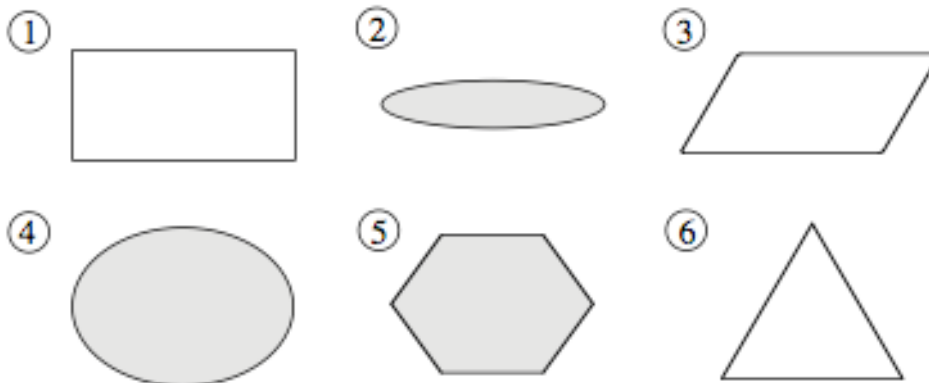

Which of the following pairs of objects are most alike in their shape?

- a. Objects 1 and 2.
- b. Objects 1 and 3.
- c. Objects 1 and 5.
- d. Objects 2 and 3.
- e. Objects 2 and 6.

Note. Instruments included: Demographic questionnaire. BARSTL from "Development and Validation of the Beliefs About Reformed Science Teaching and Learning (BARSTL) questionnaire," by V. Sampson and A. Benton, 2006, Paper presented at the Annual Conference of the Association of Science Teacher Education (ASTE), Portland, OR. & MOSART from "Project MOSART, NSF 0412382, Test Form 712," 2007, The President and Fellows of Harvard College.

APPENDIX B

**New York State Education Department
Conversion Chart for Determining a Student's
Final Science Test Score**

2009 Grade 4 ELS Conversion Chart for Determining a Student's Final Test Score

Grade 4 Elementary-Level Science Spring 2009 Performance Test Form A Raw Score																											
	26	25	24	23	22	21	20	19	18	17	16	15	14	13	12	11	10	9	8	7	6	5	4	3	2	1	0
45	100	99	98	98	97	96	96	95	95	94	94	93	92	92	91	90	90	89	88	87	85	84	83	81	79	77	75
44	99	98	98	97	96	96	95	94	94	93	93	92	92	91	90	90	89	88	87	86	85	83	82	80	78	76	74
43	98	97	96	95	95	94	93	93	92	92	91	91	90	90	89	88	87	86	85	84	83	82	80	79	77	75	73
42	97	96	95	95	94	93	93	92	92	91	91	90	89	89	88	87	87	86	85	84	82	81	80	78	76	74	72
41	96	95	94	93	92	92	91	91	90	90	89	88	88	87	87	86	85	84	83	82	81	80	78	76	75	73	71
40	95	94	93	92	92	91	90	90	89	89	88	88	87	87	86	85	84	83	82	81	80	79	77	76	74	72	70
39	93	92	92	91	90	90	89	88	88	87	87	86	86	85	84	84	83	82	81	80	79	77	76	74	72	70	68
38	93	92	91	90	89	89	88	88	87	87	86	85	85	84	84	83	82	81	80	79	78	77	75	73	72	70	68
37	91	90	89	89	88	87	87	86	86	85	85	84	83	83	82	81	81	80	79	78	76	75	74	72	70	68	66
36	90	89	89	88	87	87	86	85	85	84	84	83	83	82	81	81	80	79	78	77	76	74	73	71	69	67	65
35	89	88	87	86	86	85	84	84	83	83	82	82	81	81	80	79	78	77	76	75	74	73	71	70	68	66	64
34	87	86	86	85	84	84	83	82	82	81	81	80	80	79	78	78	77	76	75	74	73	71	70	68	66	64	62
33	86	85	84	83	83	82	81	81	80	80	79	79	78	78	77	76	75	74	73	72	71	70	68	67	65	63	61
32	84	83	83	82	81	81	80	79	79	78	78	77	77	76	75	75	74	73	72	71	70	68	67	65	63	61	59
31	83	82	81	80	80	79	78	78	77	77	76	76	75	75	74	73	72	71	70	69	68	67	65	64	62	60	58
30	81	80	79	78	77	77	76	76	75	75	74	73	73	72	72	71	70	69	68	67	66	65	63	61	60	58	56
29	79	78	77	77	76	75	75	74	74	73	73	72	71	71	70	69	69	68	67	66	64	63	62	60	58	56	54
28	77	76	75	74	74	73	72	72	71	71	70	70	69	69	68	67	66	65	64	63	62	61	59	58	56	54	52
27	75	74	74	73	72	72	71	70	70	69	69	68	68	67	66	66	65	64	63	62	61	59	58	56	54	52	50
26	74	73	72	71	71	70	69	69	68	68	67	67	66	66	65	64	63	62	61	60	59	58	56	55	53	51	49
25	71	70	69	68	68	67	66	66	65	65	64	64	63	63	62	61	60	59	58	57	56	55	53	52	50	48	46
24	69	68	68	67	66	66	65	64	64	63	63	62	62	61	60	60	59	58	57	56	55	53	52	50	48	46	44
23	67	66	65	65	64	63	63	62	62	61	61	60	59	59	58	57	57	56	55	54	52	51	50	48	46	44	42
22	65	64	63	62	62	61	60	60	59	59	58	58	57	57	56	55	54	53	52	51	50	49	47	46	44	42	40
21	63	62	61	60	59	59	58	58	57	57	56	55	55	54	54	53	52	51	50	49	48	47	45	43	42	40	38
20	60	59	59	58	57	56	55	55	54	54	53	53	52	51	51	50	49	48	47	46	44	43	41	39	37	35	33
19	58	57	56	56	55	54	54	53	53	52	52	51	50	49	48	48	47	46	45	44	43	42	41	39	37	35	33
18	56	55	54	53	53	52	51	51	50	50	49	49	48	48	47	46	45	44	43	42	41	40	38	37	35	33	31
17	54	53	52	51	50	50	49	49	48	48	47	46	46	45	45	44	43	42	41	40	39	38	36	34	33	31	29
16	51	50	50	49	48	48	47	46	46	45	45	44	44	43	42	42	41	40	39	38	37	35	34	32	30	28	26
15	49	48	47	47	46	45	45	44	44	43	43	42	41	41	40	39	39	38	37	36	34	33	32	30	28	26	24
14	48	47	46	45	44	44	43	43	42	42	41	40	40	39	39	38	37	36	35	34	33	32	30	28	27	25	23
13	45	44	44	43	42	42	41	40	40	39	39	38	38	37	36	36	35	34	33	32	31	29	28	26	24	22	20
12	43	42	41	41	40	39	39	38	38	37	37	36	35	35	34	33	33	32	31	30	28	27	26	24	22	20	18
11	41	40	39	38	38	37	36	36	35	35	34	34	33	33	32	31	30	29	28	27	26	25	23	22	20	18	16
10	39	38	38	37	36	36	35	34	34	33	33	32	32	31	30	30	29	28	27	26	25	23	22	20	18	16	14
9	37	36	35	35	34	33	33	32	32	31	31	30	29	29	28	27	27	26	25	24	22	21	20	18	16	14	12
8	36	35	34	33	32	32	31	31	30	30	29	28	28	27	27	26	25	24	23	22	21	20	18	16	15	13	11
7	34	33	32	32	31	30	30	29	29	28	28	27	26	26	25	24	24	23	22	21	19	18	17	15	13	11	9
6	33	32	31	30	29	29	28	28	27	27	26	25	25	24	24	23	22	21	20	19	18	17	15	13	12	10	8
5	31	30	29	29	28	27	27	26	26	25	25	24	23	23	22	21	21	20	19	18	16	15	14	12	10	8	6
4	30	29	28	27	26	26	25	25	24	24	23	22	22	21	21	20	19	18	17	16	15	14	12	10	9	7	5
3	28	27	26	26	25	24	24	23	23	22	22	21	20	20	19	18	18	17	16	15	13	12	11	9	7	5	3
2	27	26	26	25	24	24	23	22	22	21	21	20	20	19	18	18	17	16	15	14	13	11	10	8	6	4	2
1	26	25	24	23	23	22	21	21	20	20	19	19	18	18	17	16	15	14	13	12	11	10	8	7	5	3	1
0	25	24	23	23	22	21	21	20	20	19	19	18	17	17	16	15	15	14	13	12	10	9	8	6	4	2	0

APPENDIX C**New York State
Grade 4 Elementary-Level Science Test**

THE UNIVERSITY OF THE STATE OF NEW YORK

GRADE 4

ELEMENTARY-LEVEL SCIENCE TEST

WRITTEN TEST

SPRING 2009

Student Name _____

School Name _____

Print your name and the name of your school on the lines above.

The test has two parts. Parts I and II are in this test booklet.

Part I contains 30 multiple-choice questions. Record your answers to these questions on the separate answer sheet. Use only a No. 2 pencil on your answer sheet.

Part II consists of 10 open-ended questions. Write your answers to Part II in this test booklet.

You will have as much time as you need to answer the questions.

DO NOT TURN THIS PAGE UNTIL YOU ARE TOLD TO DO SO.

Copyright 2009
THE UNIVERSITY OF THE STATE OF NEW YORK
THE STATE EDUCATION DEPARTMENT
ALBANY, NEW YORK 12234

NO PART OF THIS TEST MAY BE REPRODUCED AND/OR TRANSMITTED BY ANY MEANS WITHOUT WRITTEN PERMISSION.

DIRECTIONS

There are 30 questions on Part I of this test. Each question is followed by three or four choices, labeled A–D. Read each question carefully. Decide which choice is the best answer. On the separate answer sheet, mark your answer in the row of circles for each question by filling in the circle that has the same letter as the answer you have chosen. Use a No. 2 pencil to mark the answer sheet.

Read Sample Question **S-1** below.

S-1 Frozen water is called

- A fog
- B ice
- C steam
- D vapor

The correct answer is **ice**, which is next to letter **B**. On your answer sheet, look at the box showing the row of answer circles for Sample Question **S-1**. See how the circle for letter **B** has been filled in.

Now do Sample Question **S-2**. Mark your answer on the answer sheet in the box showing the row of answer circles for Sample Question **S-2**.

S-2 Which animal has wings?

- A bird
- B frog
- C mouse
- D rabbit

The correct answer is **bird**, which is next to letter **A**. On your answer sheet, you should have filled in circle **A**.

Answer all 30 questions on Part I of this test. Fill in only one circle for each question. Be sure to erase completely any answer you want to change. You may not know the answers to some of the questions, but do the best you can on each one.

When you have finished Part I, go on to Part II. Answer all of the questions in Part II in the space for each question.

- 1 Windy, cloudy, rainy, and cold are words that help describe
 - A evaporation
 - B deposition
 - C matter
 - D weather

- 2 Which sense can be used to determine an object's ability to reflect light?
 - A sight
 - B hearing
 - C smell
 - D taste

- 3 A student drops a ball. Which force causes the ball to fall to the ground?
 - A electricity
 - B friction
 - C gravity
 - D magnetism

- 4 When an ice cube melts, its state of matter changes from a
 - A gas to a liquid
 - B solid to a liquid
 - C liquid to a solid
 - D solid to a gas

- 5 Which unit can be used to describe an object's length?
 - A grams
 - B minutes
 - C liters
 - D meters

Base your answers to questions 6 and 7 on the information below and on your knowledge of science.

A group of students completed a float or sink experiment. They put six objects into a bucket of water. The objects were made of three different materials: clay, plastic, and steel. The diagram below shows the results of the experiment.

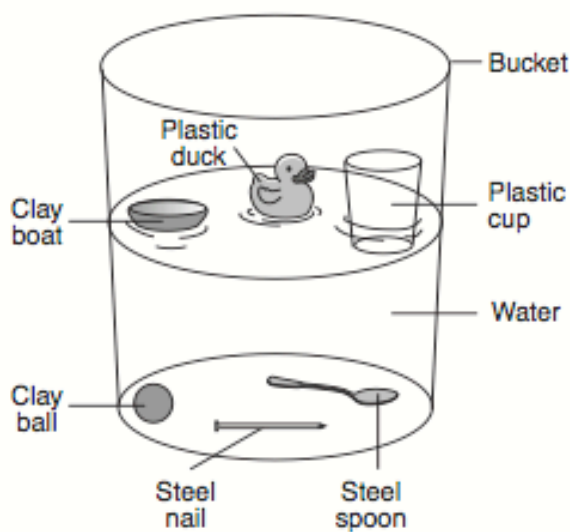

Note that question 6 has only three choices.

- 6** Which material always sank in this experiment?
- A clay
 - B plastic
 - C steel
- 7** The clay boat and clay ball have the same mass. Which property causes the boat to float and the ball to sink?
- A color
 - B mass
 - C shape
 - D texture

Note that question 8 has only three choices.

8 The diagram below shows a glass of water and a rock.

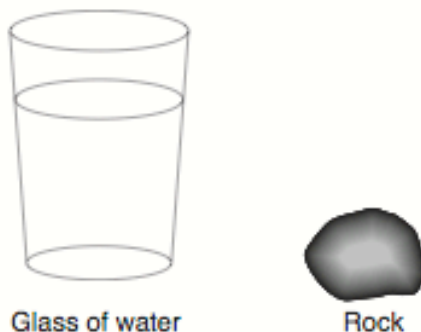

When the rock is placed into the glass, the water level will

- A decrease
 - B increase
 - C remain the same
- 9** How long does it take for Earth to rotate on its axis seven times?
- A one day
 - B one week
 - C one month
 - D one year
- 10** What form of energy is being used when a person pushes a wooden block across the floor?
- A mechanical
 - B magnetic
 - C sound
 - D electrical

11 The diagram below shows an electrical circuit.

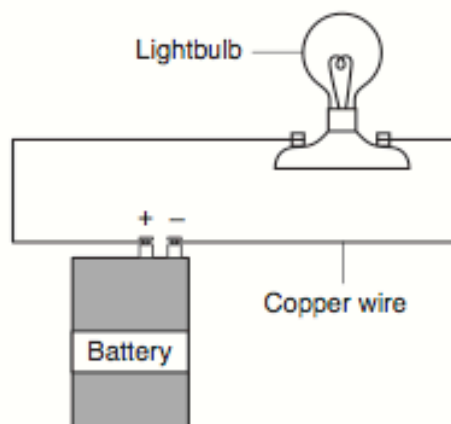

The purpose of the copper wire is to

- A conduct electricity
- B produce electricity
- C store electricity
- D stop the flow of electricity

Note that question 12 has only three choices.

- 12 A student measured the volume of water in a pan. The student boiled the water for thirty minutes and then measured the volume of the water again. The volume of water most likely
- A decreased
 - B increased
 - C remained the same

- 13 The diagram below shows the effect of a river on an area over many years.

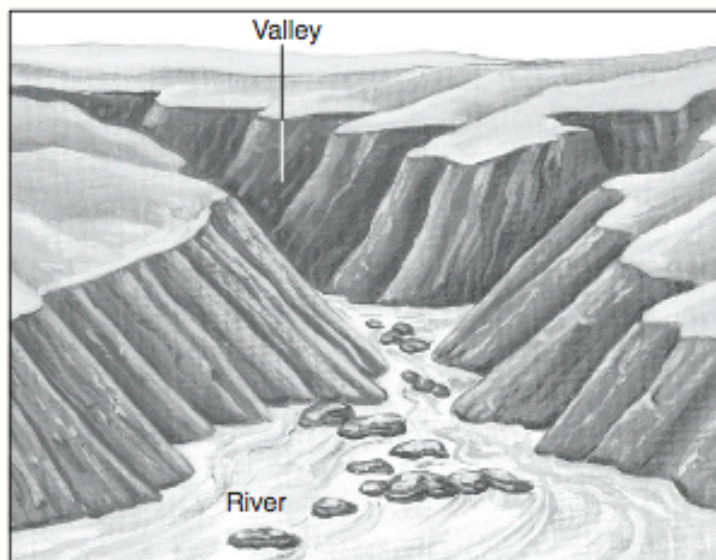

- Which process caused the valley to form?
- A condensation
 - B deposition
 - C erosion
 - D evaporation
- 14 Which physical structure would best help a bear to survive a winter in New York State?
- A big ears
 - B black nose
 - C thick fur
 - D brown eyes
- 15 What do all animals need in order to survive?
- A rocks, water, and soil
 - B water, air, and food
 - C air, rocks, and sunlight
 - D food, soil, and sunlight

16 The diagram below shows a lodge where beavers live.

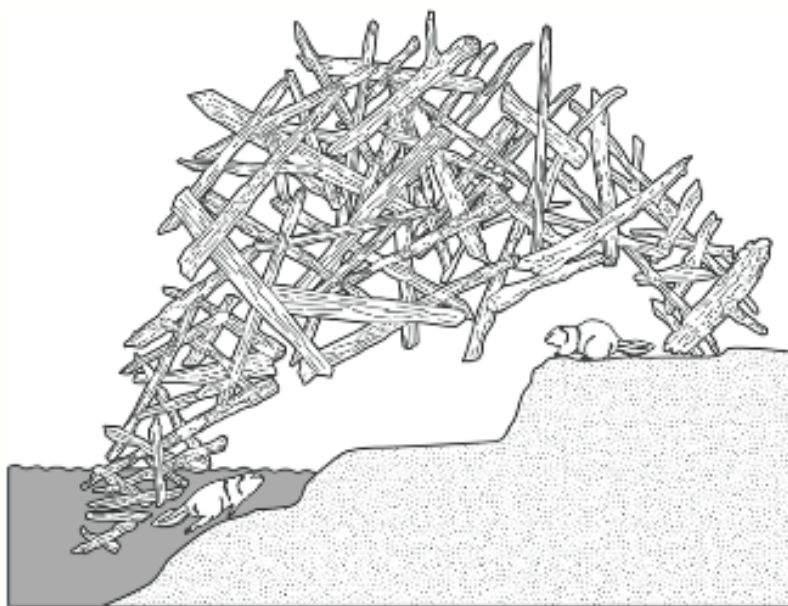

This diagram shows that beavers need trees for

- A air
- B water
- C sunlight
- D shelter

17 During winter, the white fur of an arctic fox blends in with the snow. This adaptation is called

- A hibernation
- B migration
- C camouflage
- D movement

18 The diagram below shows a fox and an owl both trying to catch a rabbit



(Not drawn to scale)

The fox and the owl are both

- A finding a mate
- B competing for food
- C seeking shelter
- D migrating for winter

19 Since green plants make their own food, they are called

- A predators
- B prey
- C decomposers
- D producers

20 Which structure of a bird is correctly paired with its function?

- A claws for obtaining food
- B wings for eliminating waste
- C feathers for breathing
- D eyes for growing

- 21 The diagram below shows the life cycle of a frog. Four stages of development are labeled *A*, *B*, *C*, and *D*.

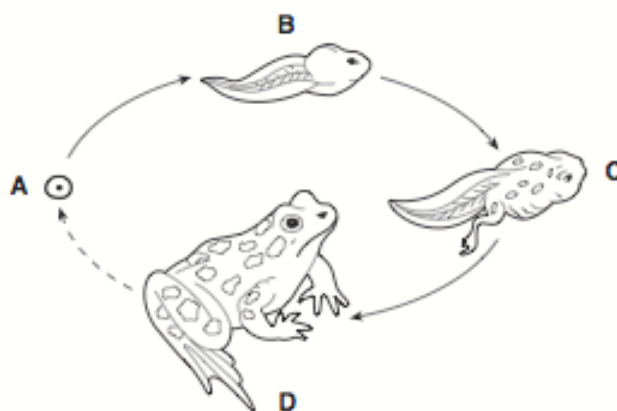

(Not drawn to scale)

Which letter shows the adult stage of development?

- A *A*
 - B *B*
 - C *C*
 - D *D*
- 22 Humans depend on which natural resource from the environment?
- A water
 - B houses
 - C electricity
 - D roads
- 23 Which characteristic can a puppy inherit from its parents?
- A muddy paws
 - B spotted fur
 - C broken foot
 - D scar on face

- 24** Many birds fly south for the winter. This adaptation is called
- A hibernation
 - B germination
 - C migration
 - D communication
- 25** Green plants get the energy they need to make food from
- A air
 - B sunlight
 - C water
 - D soil
- 26** When plants and animals die, which organisms help return nutrients to the food chain?
- A decomposers
 - B predators
 - C prey
 - D producers
- 27** Some butterflies live an average of two weeks. This period of time is called a life
- A process
 - B span
 - C change
 - D cycle
- 28** During an experiment, a student reports that a liquid turned green when mixed with another liquid. This is an example of
- A a measurement
 - B a prediction
 - C an explanation
 - D an observation

- 29 The data table below shows the height of a bean plant over a three-month period. The height of the plant is recorded in centimeters (cm).

Height of a Bean Plant

Month	Height
March	4 cm
April	9 cm
May	14 cm

If the pattern shown continues, the height of the plant in June will be

- A 6 cm
- B 12 cm
- C 14 cm
- D 19 cm

Note that question 30 has only three choices.

- 30 The diagram below shows a food chain.

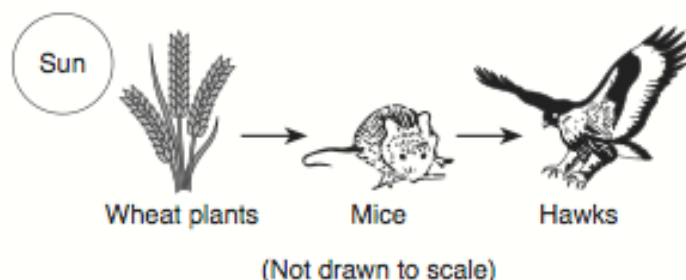

If the wheat plants died, the population of mice would most likely

- A decrease
- B increase
- C remain the same

GO RIGHT ON TO PART II ⇔

Part II

Directions (31–40): Record your answers in the space provided below each question.

- 31** The diagram below shows the water cycle. Four stages are labeled *A*, *B*, *C*, and *D*.

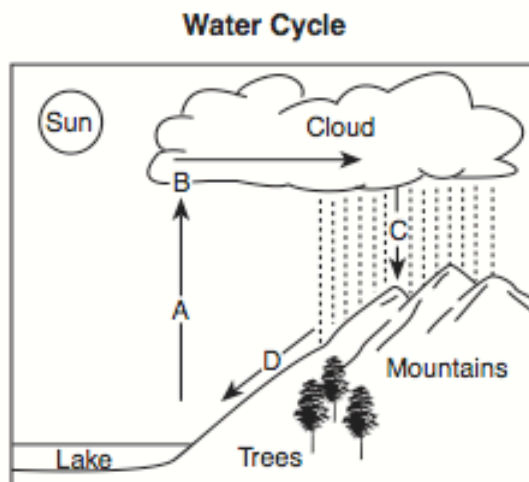

In the chart below, write the letter that represents each stage of the water cycle shown. [2]

Stage	Letter
condensation	
evaporation	
precipitation	
runoff	

Base your answers to questions 32 through 34 on the data table below and on your knowledge of science. The data table shows four properties of five different objects. The properties are labeled *A*, *B*, *C*, and *D*. Properties *A* and *B* are identified.

Data Table

Object	Property			
	A Mass	B Color	C _____	D _____
1	25 grams	red	smooth	sphere
2	35 grams	yellow	rough	cylinder
3	30 grams	green	smooth	cube
4	25 grams	red	rough	sphere
5	30 grams	blue	smooth	cube

32 Identify property *C*. [1] _____

33 Identify property *D*. [1] _____

34 Which **two** objects are both smooth cubes? [1]

Object number: _____

Object number: _____

- 35** Complete the chart below by identifying the scientific tool used to measure each of the physical properties listed. The scientific tool in the first row is shown. [2]

Some Properties Measured by Tools

Property	Scientific Tool
mass	pan balance
volume of a liquid	
temperature	



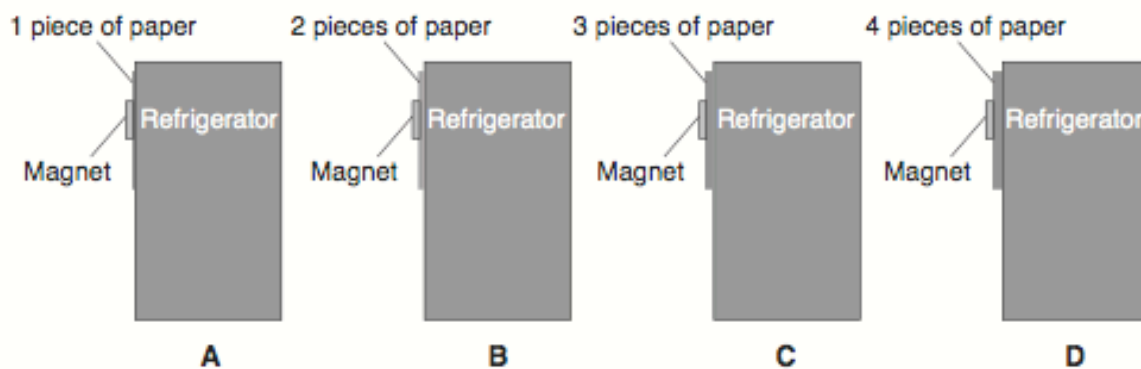

- 36** The diagrams below show identical magnets holding pieces of paper on a refrigerator. [1]



Explain why adding more paper to the refrigerator in diagram *D* might cause the magnet to fall off. [1]

- 37 The diagram below shows the growth and development of a bean seed into a plant.

Growth and Development of a Bean Seed into a Plant

Stage	A	B	C	D
Length (cm)	0.6 cm	2.0 cm	7.0 cm	11.0 cm
Appearance of Seed/Plant				

(Not drawn to scale)

How much has the bean plant grown from stage *B* to stage *D*? [1]

_____ cm

- 38 Complete the chart below by describing **one** way that some trees respond to each change in season listed. [2]

Ways that Some Trees Respond to Changes in Season

Change in Season	Way that Some Trees Respond
summer changing to fall	
winter changing to spring	

- 39 The diagram below shows an area before and after a housing development was built there.

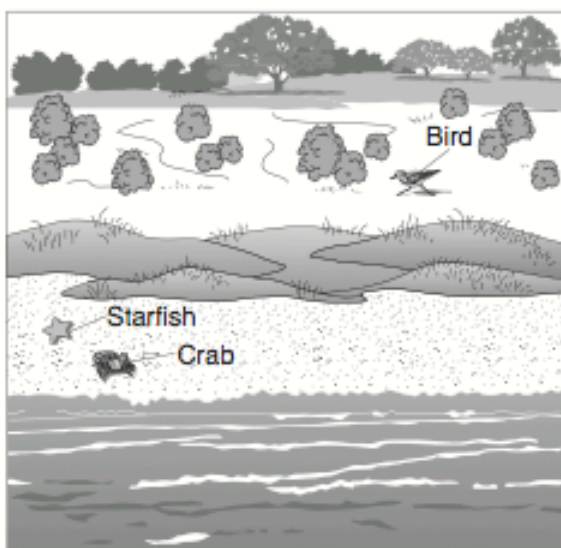

Before Development

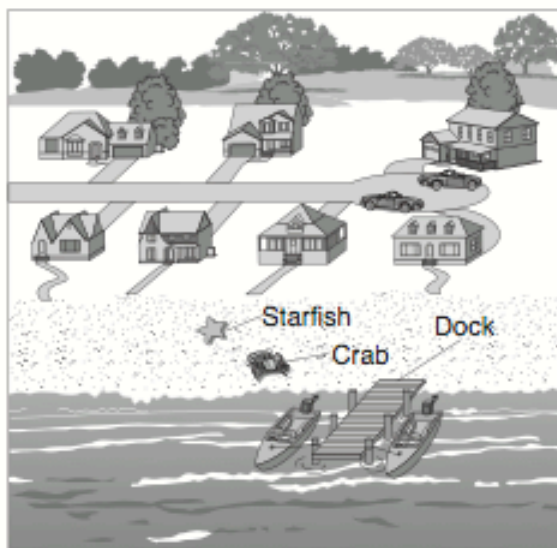

After Development

(Not drawn to scale)

Describe **two negative** ways that the animals living in the area have been affected by the changes shown in the diagram. [2]

(1) _____

(2) _____

- 40 The chart below shows the main functions of some green plant structures. Complete the chart by identifying the structure that performs **each** function. The green plant structure in the first row is shown. [2]

Main Functions of Some Green Plant Structures

Main Function	Green Plant Structure
supports the plant	stem
produces food for the plant	
takes in water and nutrients	
produces seeds	

APPENDIX D

**First Pre-Notification
Email Message For Principals**



SYRACUSE UNIVERSITY

DEPARTMENT OF SCIENCE TEACHING

Email Script: Pre-Notification Email and Mass Email Solicitation (they are the same)

Project Title: Investigating elementary principals' leadership content knowledge in science and its relationship to student outcomes

My name is Uzma Khan, and I am a doctoral student in Teaching and Curriculum in the School of Education at Syracuse University. If you are 18 years or older, I am inviting you to participate in a research study by completing an online survey. Involvement in the research is voluntary, so you may choose to participate or not. You will receive two additional emails from me regarding this survey. The next email will be sent to you after two days with a unique link to an online survey. If I do not receive your survey within four days, I will send you only one email reminder.

The survey will include questions that will allow me to understand the nature of elementary school principals' beliefs about science teaching and learning and their science subject matter knowledge. I am particularly interested in exploring the relationship between the context of schools, principals' beliefs about science teaching and learning, and principals' science subject matter knowledge to students' science outcomes.

The survey will take approximately 25-30 minutes and will include a progress bar at the bottom of each page to inform you of the number of pages out of the total that you have answered. You can only take the survey in one sitting. Therefore, if you think that you may be interested in taking the survey, please click on the link only when you think you may have time to take it. You will not be able to return to the survey once you have clicked on the link to take it and then log out. The survey consists of a few background questions, 32 questions regarding your beliefs about reformed science teaching and learning, and 20 science subject questions. In appreciation of your time, the surveys returned to me will be entered into a drawing for one of five \$200.00 Visa gift cards. The odds of winning a gift card are 1 in 90. If your name is drawn for one of the gift cards, you will be notified by email by July 1, 2010.

All information in the survey will be kept anonymous and confidential; your name will not appear anywhere and no one will know about your specific answers except me and my dissertation committee chair, Dr. Sharon Dotger. I will assign a number to your responses and I will have the key to indicate which number belongs to which participant. In any articles we write or any presentations that we make, we will not use any names or descriptive identifiers.

The benefit of this research is that you will be helping me to understand how multiple school contextual factors and principals' personal characteristics, beliefs, and science knowledge may influence students' science outcomes. Understanding the interaction of these multiple factors and

Syracuse University
IRB Approved

1

EXPIRES

MAR 30 2011

101 Heroy Geology Hall | Syracuse, New York 13244-1070 | 315-443-2586

complex role of the principal can help in improving principal preparation programs. The knowledge gained may also help improve reform efforts in principal leadership and science education.

As you take the survey, the benefits for you may include having time to reflect on the relationships between the multiple contexts of schools, your personal characteristics, your beliefs about science teaching and learning, your science knowledge and students' science outcomes. Your insights may also inform you on ways to improve science teaching in your schools and meet the challenges of the profession. The risks to you of participating in this research are minimal and may include being inconvenienced by having to devote time to complete the survey. You may also feel uncomfortable answering some of the questions.

If you do not want to take part in the survey, you have the right to refuse to take part, without penalty. If you decide to take part and later no longer wish to continue, you have the right to withdraw from the survey at any time, without penalty. If you have any questions about your rights as a research participant, concerns, or complaints that you wish to address, you may contact me, Uzma Khan at 315-443-4916 or umkhan@syr.edu. You may also contact Dr. Sharon Dotger at 315-443-9138 or sdotger@syr.edu. If you would like to speak to someone other than myself, Uzma Khan or Dr. Sharon Dotger, or if you cannot reach us, please contact the Syracuse University Institutional Review Board at 315-443-3013.

If you would like to take the survey, please click on your unique link (SurveyMonkey will have a unique link here), and the survey will appear in a new window. By continuing the survey, you agree to give consent. Please print a copy of this page for your records.

Thank you for your time.

Sincerely,

Uzma Khan
Graduate Student
Syracuse University

Syracuse University
IRB Approved

EXPIRES

MAR 30 2011

2

APPENDIX E

**Second Email Message
For Principals
(Unique Survey Link)**



SYRACUSE UNIVERSITY

DEPARTMENT OF SCIENCE TEACHING

Second Email: Includes link to the survey

Project Title: Investigating elementary principals' leadership content knowledge in science and its relationship to student outcomes

My name is Uzma Khan, and I am a doctoral student in Teaching and Curriculum in the School of Education at Syracuse University. I sent you an email two days ago inviting you to participate in my research by completing an online survey if you are 18 years or older. Involvement in the research is voluntary, so you may choose to participate or not.

The survey includes questions that will allow me to understand the nature of elementary school principals' beliefs about reformed science teaching and learning and science subject matter knowledge by examining their relationship to students' science achievement within the context of the school. The survey will take approximately 25-30 minutes of your time and includes a progress bar at the bottom of each page to inform you of the number of pages out of the total that you have answered. Please remember that you can only take the survey in one sitting. Therefore, if you think that you may be interested in taking the survey, please click on the link only when you think you may have time to take it. You will not be able to return to the survey once you have clicked on the link to take it and then log out.

The survey consists of a few background questions, 32 questions regarding your beliefs about reformed science teaching and learning, and 20 science subject questions. In appreciation of your time, the surveys returned to me will be entered into a drawing for one of five \$200.00 Visa gift cards. The odds of winning a gift card are 1 in 90. If your name is drawn for one of the gift cards, you will be notified by email by July 1, 2010.

All information in the survey will be kept anonymous and confidential; your name will not appear anywhere and no one will know about your specific answers except me and my dissertation committee chair, Dr. Sharon Dotger. I will assign a number to your responses and I will have the key to indicate which number belongs to which participant. In any articles we write or any presentations that we make, we will not use any names or descriptive identifiers. Data will be discussed in terms of the specific factors that influence students' science outcomes.

If you do not want to take part in the survey, you have the right to refuse to take part, without penalty. If you decide to take part and later no longer wish to continue, you have the right to withdraw from the survey at any time, without penalty. If you have any questions about your rights as a research participant, concerns, or complaints that you wish to address, you may

Syracuse University
IRB Approved

EXPIRES

MAR 30 2011

1

contact me, Uzma Khan at 315-443-4916 or umkhan@syr.edu . You may also contact Dr. Sharon Dotger at 315-443-9138 or sdotger@syr.edu. If you would like to speak to someone other than myself, Uzma Khan, or Dr. Sharon Dotger, or if you cannot reach us, please contact the Syracuse University Institutional Review Board at 315-443-3013.

If you would like to take the survey, please click on your unique link (SurveyMonkey will have a unique link here), and the survey will appear in a new window. By continuing the survey, you agree to give consent. Please print a copy of this page for your records.

In case you do not have time to look at the survey at this time, you will receive only one email reminder from me after four days.

Thank you for your time.

Sincerely,

Uzma Khan
Graduate Student
Syracuse University

Syracuse University
IRB Approved

EXPIRES

MAR 30 2011

APPENDIX F

Follow-Up Email Message



SYRACUSE UNIVERSITY

DEPARTMENT OF SCIENCE TEACHING

Third Email: Follow-up reminder if survey has not been returned.

Project Title: Investigating elementary principals' leadership content knowledge in science and its relationship to student outcomes

My name is Uzma Khan, and I am a doctoral student in Teaching and Curriculum in the School of Education at Syracuse University. This is a friendly reminder that I invited you to participate in my research study by completing an online survey if you are over the age of 18. I sent you an email with a link to the survey four days ago. Involvement in the research is voluntary, so you may choose to participate or not. You will not receive any additional emails from me regarding my research or survey.

The survey includes questions that will allow me to understand the nature of elementary school principals' beliefs about reformed science teaching and learning and science subject matter knowledge by examining their relationship to students' science achievement within the context of the school. It will take approximately 30 minutes of your time and consists of a few background questions, 32 questions regarding your beliefs about reformed science teaching and learning, and 20 science subject questions. In appreciation of your time, the surveys returned to me will be entered into a drawing for one of five \$200.00 Visa gift cards. The odds of winning a gift card are 1 in 90. If your name is drawn for one of the gift cards, you will be notified by email by July 1, 2010.

All information in the survey will be kept anonymous and confidential; your name will not appear anywhere and no one will know about your specific answers except me and my dissertation committee chair, Dr. Sharon Dotger. I will assign a number to your responses and I will have the key to indicate which number belongs to which participant. In any articles we write or any presentations that we make, we will not use any names or descriptive identifiers. Data will be discussed in terms of the specific factors that influence students' science outcomes.

If you do not want to take part in the survey, you have the right to refuse to take part, without penalty. If you decide to take part and later no longer wish to continue, you have the right to withdraw from the survey at any time, without penalty. If you have any questions about your rights as a research participant, concerns, or complaints that you wish to address, you may contact me, Uzma Khan at 315-443-4916 or umkhan@syr.edu. You may also contact Dr. Sharon Dotger at 315-443-9138 or sdotger@syr.edu. If you would like to speak to someone other than myself, Uzma Khan or Dr. Sharon Dotger, or if you cannot reach us, please contact the Syracuse University Institutional Review Board at 315-443-3013.

Syracuse University
IRB Approved

EXPIRES

MAR 30 2011

1

If you would like to take the survey, please click on your unique link (SurveyMonkey will have a unique link here), and the survey will appear in a new window. By continuing the survey, you agree to give consent. Please print a copy of this page for your records.

If you wish to complete this survey, but do not have time at the moment, I would appreciate it if you could return it to me within three days.

Thank you for your time.

Sincerely,

Uzma Khan
Graduate Student
Syracuse University

Syracuse University
IRB Approved

EXPIRES

MAR 30 2011

APPENDIX G*

**2008-2009 Statewide Accountability Report
For
New York State
(New York State Report Card)**

* Data relevant to elementary science included.

2 Statewide Accountability

Summary

On which accountability measures did the state make Adequate Yearly Progress (AYP) and which groups made AYP on each measure?

Student Groups	Elementary/Middle Level			Secondary Level		
	English Language Arts	Mathematics	Science	English Language Arts	Mathematics	Graduation Rate
All Students	✓	✓	✓	✓	✓	✓
Ethnicity						
American Indian or Alaska Native	✓	✓		✓ ^{SH}	✓	
Black or African American	✓	✓		✓ ^{SH}	✗	
Hispanic or Latino	✓	✓		✓ ^{SH}	✓ ^{SH}	
Asian or Native Hawaiian/Other Pacific Islander	✓	✓		✓	✓	
White	✓	✓		✓	✓	
Multiracial	✓	✓		✓	✓	
Other Groups						
Students with Disabilities	✓ ^{SH}	✓		✗	✗	
Limited English Proficient	✓ ^{SH}	✓		✗	✓ ^{SH}	
Economically Disadvantaged	✓	✓		✓ ^{SH}	✓	
Student groups making AYP in each subject	✓ 10 of 10	✓ 10 of 10	✓ 1 of 1	✗ 8 of 10	✗ 8 of 10	✓ 1 of 1

AYP Status























- ✓ Made AYP
- ✓^{SH} Made AYP Using Safe Harbor Target
- ✗ Did Not Make AYP
- Insufficient Number of Students to Determine AYP Status

2 Statewide Accountability



Elementary/Middle-Level Science

Accountability Measures 1 of 1 Student groups making AYP in science
 Made AYP

How did students in each accountability group perform on elementary/middle-level science accountability measures?

Student Group (Total, Continuous Enrollment) ¹	AYP		Participation		Test Performance		Performance Objectives	
	Status	Safe Harbor Qualification	Met Criterion	Percentage Tested	Met Criterion	Performance Index	State Standard	Progress Target 2008-09 2009-10
All Students (414,664:394,232)		Qualified		98%		176	100	
Ethnicity								
American Indian or Alaska Native (1,947:1,796)		Qualified		97%		170	100	
Black or African American (79,661:73,571)		Qualified		97%		154	100	
Hispanic or Latino (87,493:81,309)		Qualified		98%		157	100	
Asian or Native Hawaiian/Other Pacific Islander (31,347:29,782)		Qualified		99%		185	100	
White (213,267:206,986)		Qualified		99%		190	100	
Multiracial (949:788)		Qualified		98%		184	100	
Other Groups								
Students with Disabilities (69,305:63,785)		Qualified		96%		144	100	
Limited English Proficient ² (29,524:26,427)		Qualified		98%		129	100	
Economically Disadvantaged (207,077:193,811)		Qualified		98%		162	100	
Final AYP Determination		1 of 1						

AYP Status

-  Made AYP
-  Made AYP Using Safe Harbor Target
-  Did Not Make AYP
- Insufficient Number of Students to Determine AYP Status

NOTES

- ¹ These data show the count of students enrolled during the test administration period (used for Participation) followed by the count of continuously enrolled tested students (used for Performance). For accountability calculations, students who were excused from testing for medical reasons are not included in the enrollment count.
- ² If the count of LEP students is equal to or greater than 30, former LEP students are also included in the performance calculations.

3 Overview of Statewide Performance

Summary of 2008–09 Statewide Performance

Performance on the State assessments in English language arts, mathematics, and science at the elementary and middle levels is reported in terms of mean scores and the percentage of tested students scoring at or above Level 2, Level 3, and Level 4. Performance on the State assessments in ELA and mathematics at the secondary level is reported in terms of the percentage of students in a cohort scoring at these levels.

	Percentage of students that scored at or above Level 3			Total Tested
	0%	50%	100%	
English Language Arts				
Grade 3	76%			198,219
Grade 4	77%			195,827
Grade 5	82%			197,765
Grade 6	81%			197,931
Grade 7	80%			202,679
Grade 8	69%			207,409
Mathematics				
Grade 3	93%			200,184
Grade 4	87%			197,561
Grade 5	88%			199,452
Grade 6	83%			199,915
Grade 7	87%			204,585
Grade 8	80%			209,215
Science				
Grade 4	88%			196,825
Grade 8	68%			185,178

	Percentage of students that scored at or above Level 3			2005 Total Cohort
	0%	50%	100%	
Secondary Level				
English	77%			224,902
Mathematics	77%			224,902

About the Performance Level Descriptors

Level 1: Not Meeting Learning Standards. Student performance does not demonstrate an understanding of the content expected in the subject and grade level.

Level 2: Partially Meeting Learning Standards. Student performance demonstrates a partial understanding of the content expected in the subject and grade level.

Level 3: Meeting Learning Standards. Student performance demonstrates an understanding of the content expected in the subject and grade level.

Level 4: Meeting Learning Standards with Distinction. Student performance demonstrates a thorough understanding of the content expected in the subject and grade level.

3 Overview of Statewide Performance

Statewide Results in Grade 4 Science

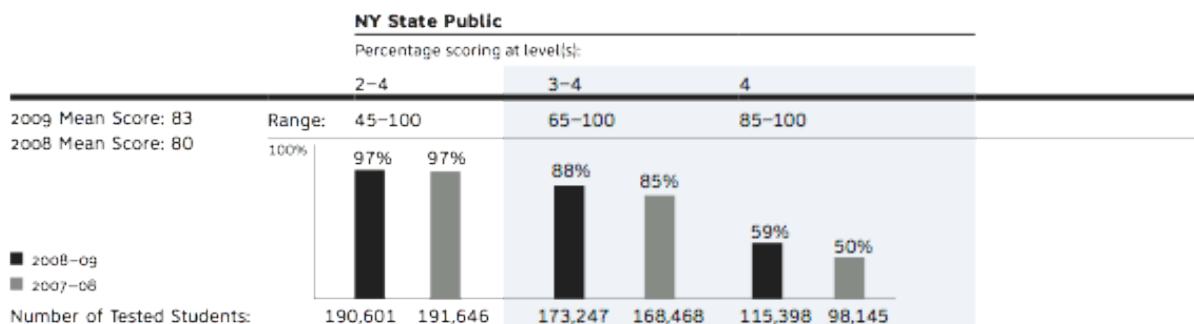

Results by Student Group

	2008-09 School Year				2007-08 School Year			
	Total Tested	Percentage scoring at level(s):			Total Tested	Percentage scoring at level(s):		
		2-4	3-4	4		2-4	3-4	4
All Students	196,825	97%	88%	59%	197,708	97%	85%	50%
Female	95,744	97%	88%	58%	96,828	97%	85%	49%
Male	101,081	97%	88%	59%	100,880	97%	85%	50%
American Indian or Alaska Native	891	96%	87%	51%	915	96%	81%	40%
Black or African American	37,424	94%	79%	40%	37,762	94%	72%	29%
Hispanic or Latino	42,319	94%	79%	41%	41,977	94%	73%	30%
Asian or Native Hawaiian/Other Pacific Islander	15,197	98%	93%	72%	14,780	98%	91%	62%
White	100,417	99%	95%	71%	102,018	99%	94%	64%
Multiracial	577	97%	90%	61%	256	96%	88%	52%
Small Group Totals	0	—	—	—	0	—	—	—
General-Education Students	166,025	98%	92%	64%	166,076	98%	89%	55%
Students with Disabilities	30,800	90%	69%	28%	31,632	90%	64%	20%
English Proficient	180,201	98%	90%	62%	181,376	98%	88%	53%
Limited English Proficient	16,624	87%	63%	22%	16,332	86%	55%	13%
Economically Disadvantaged	102,793	95%	81%	44%	100,257	95%	76%	33%
Not Disadvantaged	94,032	99%	95%	75%	97,451	99%	95%	67%
Migrant	60	92%	75%	25%	35	97%	74%	14%
Not Migrant	196,765	97%	88%	59%	197,673	97%	85%	50%

NOTE

The — symbol indicates that data for a group of students have been suppressed. If a group has fewer than five students, data for that group and the next smallest group(s) are suppressed to protect the privacy of individual students.

Other Assessments

	2008-09 School Year				2007-08 School Year			
	Total Tested	Number scoring at level(s):			Total Tested	Number scoring at level(s):		
		2-4	3-4	4		2-4	3-4	4
New York State Alternate Assessment (NYSAA): Grade 4 Equivalent	2,423	2,349	2,282	1,880	2,191	2,071	1,987	1,547

Uzma Khan
Department of Science Teaching
107 Heroy Geology Lab
Syracuse University
Syracuse, NY 13244-9134
umkhan@syr.edu

Education

Syracuse University PhD Teaching and Curriculum Specialization/Dissertation: Science Instructional Leadership	2012
Syracuse University Doctoral Student Teaching and Curriculum	2008 - 2009
Syracuse University, Syracuse, New York Master of Science, Science Education, December 2004	2004
State University of New York-Environmental Science & Forestry Syracuse, New York Masters in Professional Studies	2004
State University of New York at New Paltz New Paltz, New York Bachelor of Science, Biology	1993

Teaching Experience

Teaching Assistant Syracuse University Teaching and Learning Science in the Undergraduate Setting: Theory and Practice EDU 800	Spring 2010
Teaching Assistant Syracuse University Methods and Curriculum in Teaching Science SCE 413/613	Spring 2010

Teaching Assistant
Syracuse University
Curriculum Problems in Science Education
SCE 718
Fall 2009

Instructor
Syracuse University
Teaching Science in Early Childhood
EED 654
Summer 2009

Student Teacher Supervisor
Syracuse University
Candidacy and Full Time Student Teachers
SED 415/615
2008 - 2009

Teaching Assistant
Syracuse University
Teacher Development in Science
SED 415/615
Fall 2008

Graduate Assistant
Syracuse University
Math Science Partnership with Syracuse City Schools
2007 - 2008

Co-Instructor
Exploring Force & Motion
30 hour In-Service Course
Syracuse City School District, New York
January - May 2008

Teacher, Corcoran High School, Syracuse, New York
• Taught International Baccalaureate Biology
• Regents Living Environment
2004 - 2007

Graduate Assistant/Teaching Assistant
Syracuse University
Pedagogy of Peer Tutoring
EDU 400/600
2003 - 2004

Grants

Research & Creative Grant Competition
Syracuse University
Exploratory Investigation of Principal Knowledge of Science Inquiry
Spring 2009

\$660.00

Burstyn Collaborative Grant Proposal
Syracuse University
Integrating Inquiry, Writing, and Inclusion via Lesson Study
\$1000.00

Fall 2008

Awards and Honors

Berj Harootunian Award Outstanding Academic Achievement Meritorious Dissertation Research in Teacher Education Syracuse University	2010
Outstanding Teaching Assistant Award Syracuse University	2010
Future Professoriate Fellow Certificate in University Teaching Syracuse University	2010
<i>Nominated</i> to Address Fellow Graduates as School of Education Convocation Speaker MS, CAS, Ph.D. Graduates	2010
<i>Nominated</i> for Teaching Fellow Syracuse University Nominated by Dr. John Tillotson	2009
<i>Nominated</i> for Teaching Fellow Syracuse University Nominated by Dr. Marvin Druger	2008
Phi Kappa Phi Honor Society Member of Chapter of Syracuse University	2008
Bristol - Myers Squibb Scholarship Award Achievement in Science Teaching \$2000.00	2003

Service/ Professional Development Workshops

Dotger, S. & Khan, U. (2007). *Literacy strategies*. Workshop for Syracuse City School District Teachers. Elmcrest School, October 24, 2007.

Dotger, S. & Khan, U. (2007). *Identifying student misconceptions*. Workshop for Syracuse City School District Teachers. Elmcrest School, November 7, 2007.

Dotger, S. & Khan, U. (2007). *Using misconception data to plan instruction*. Workshop for Syracuse City School District Teachers. Elmcrest School, November 28, 2007.

Khan, U. (2008). *Unit planning: Pre-assessment design*. Workshop for Syracuse City School District Teachers. Elmcrest School, January, 23, 2008.

Khan, U. (2008). *Unit planning one*. Workshop for Syracuse City School District Teachers. Elmcrest School, February 27, 2008.

Khan, U. (2008). *Unit planning two: Self assessment*. Workshop for Syracuse City School District Teachers. Elmcrest School, March, 19, 2008.

Khan, U. (2008). *Peer coaching cycles*. Workshop for Syracuse City School District Teachers. Elmcrest School, April 23, 2008.

Khan, U. (2008). *Classroom observations* for Syracuse City School District Teachers. Elmcrest School, May 2, 2008.

Khan, U. (2008). *Post assessments: year end reflections*. Workshop for Syracuse City School District Teachers. Elmcrest School, June 11, 2008.

Khan, U. & Cherebin, J. (2008). *Collaboration in the classroom*. Workshop for Syracuse City School District Teachers. Dr. Martin Luther King Elementary School, October 31, 2008.

Dotger, S., Mcquitty, V. & Khan, U. (2009). *Science vocabulary workshop*. Workshop for Syracuse City School District Teachers. Salem Hyde Elementary School, February 5, 2009.

Dotger, S., Mcquitty, V. & Khan, U. (2009). *Lesson study: Inquiry as a stance*. Workshop for Syracuse City School District Teachers. Salem Hyde Elementary School, February 26, 2009.

Conference Presentations

LaTray, C., Young, M., & Khan, U. (November, 2010). Narrowing the gap between the ivory tower and K-12 educators: A practitioner centered professional development. Paper presented at the Science Teachers of New York Conference, Rochester, NY.

- Khan, U., Dotger, S., & McQuitty, V. (March, 2010). Identifying micro-steps for implementing inquiry-based science in the primary grades. Paper presented at the National Association for Research in Science Teaching, Philadelphia, PA.
- Dotger, S., Khan, U., & McQuitty, V. (March, 2010). Becoming an inclusive science teacher: exploring the intersection of inquiry and inclusion in the primary classroom. Paper presented at the National Association for Research in Science Teaching, Philadelphia, PA.
- McQuitty, V., Dotger, S., & Khan, U. (March, 2010). Exploring Primary Grade Teachers' Conceptions and Implementation of Science Notebook Writing. Paper presented at the National Association for Research in Science Teaching, Philadelphia, PA.
- McQuitty, V., Dotger, S., & Khan, U. (December, 2009). Writing science/science writing: A theoretical model of the writing/science process in the elementary grades. Paper presented at the National Reading Conference, Albuquerque, NM.
- Dotger, S., Khan, U., & McQuitty, V. (May, 2009). *Exploring lesson study as a mechanism for building relationships between teachers, students, and curriculum*. Workshop presented at the New York State Staff Development Council Annual Meeting, Liverpool, NY.
- Dotger, S., & Khan, U. (May, 2008). *Responding to the challenges of leadership for inquiry teaching & learning*. Workshop presented at the New York State Staff Development Council Annual Meeting, Syracuse, NY.

Publications

- McQuitty, V., Dotger, S., & Khan, U. (2010). One without the other isn't as good as both together: A theoretical framework of integrated writing/science instruction in the primary grades. In R. T. Jimenez, M. K. Hundley, V. J. Risko & D. W. Rowe (Eds.), *59th Yearbook of the National Reading Conference* (pp. 315-328). Oak Creek, WI: National Reading Conference.

Professional Services

- Member, Faculty Tenure Teaching Committee (2009), School of Education, Syracuse University

Professional Licenses/Certifications

College Reading and Learning Association, Certified Master Tutor, Level 3

International Baccalaureate Organization, Biology Certification

New York State Teacher Certification, Secondary Education in Science and Biology,7-12

Professional Memberships

National Association for Research in Science Teaching (NARST)