

Syracuse University

SURFACE

Marriage and Family Therapy - Dissertations

David B. Falk College of Sport and Human
Dynamics

12-2011

Fibromyalgia Syndrome: The Relationship between Alexithymia and Attachment Style on Couple Relationship

Ileana Ungureanu
Syracuse University

Follow this and additional works at: https://surface.syr.edu/mft_etd

 Part of the [Counseling Psychology Commons](#)

Recommended Citation

Ungureanu, Ileana, "Fibromyalgia Syndrome: The Relationship between Alexithymia and Attachment Style on Couple Relationship" (2011). *Marriage and Family Therapy - Dissertations*. 45.

https://surface.syr.edu/mft_etd/45

This Dissertation is brought to you for free and open access by the David B. Falk College of Sport and Human Dynamics at SURFACE. It has been accepted for inclusion in Marriage and Family Therapy - Dissertations by an authorized administrator of SURFACE. For more information, please contact surface@syr.edu.

ABSTRACT

The fibromyalgia syndrome (FMS) is the most frequent cause of chronic, widespread pain in North America and Europe. It is a non-inflammatory musculoskeletal syndrome predominantly found in the female middle-aged population with a ratio men/women of 1/4. Considered for decades an 'imaginary' or at best a psychosomatic disease, fibromyalgia gained its status as a diagnosable entity in the early 90s giving a 'voice' to the invisible suffering of people, the majority of them being women afflicted by it. While in general the research on psychosocial aspects of fibromyalgia is scarce, couple and family aspects are even less studied than individual aspects. In an attempt to shed more light on the quality of couple relationship of people suffering from FMS, this study looked at the mediation effect of alexithymia and attachment style on the relationship between the impact of fibromyalgia and couple satisfaction. This is a quantitative study that employed a Structural Equation Modeling statistical analysis. The findings from this study show that neither alexithymia nor a specific attachment style is a mediator of the relationship between fibromyalgia impact and couple satisfaction. The study also shows that fibromyalgia symptoms do not have a statistically significant impact on couple adjustment. A combination of the presence of alexithymia traits and an avoidant attachment style seems to have the most powerful impact on couple satisfaction in the population suffering from fibromyalgia. Several clinical implications are highlighted as a result of this study: couple therapists working with clients with fibromyalgia should familiarize themselves with the symptoms of this syndrome and how they affect the everyday life of the partners, as well as the impact of the alexithymia traits and an insecure attachment style on the couple relationship in this population. Due to its

emphasis on emotional experiences and its psychoeducational aspects in regards to processing feelings, Emotionally-Focused Therapy is proposed to be very well suited in working with fibromyalgia sufferers and their partners, especially those with alexithymia features and insecure attachment styles.

FIBROMYALGIA SYNDROME: THE RELATIONSHIP
BETWEEN ALEXITHYMIA AND ATTACHMENT STYLE ON
COUPLE RELATIONSHIP

BY

Ileana Ungureanu

M.D. Universitatea de Medicina si Farmacie, Timisoara, Romania, 1995

M.A. Syracuse University, 2006

DISSERTATION

Submitted in partial fulfillment of the requirements for the degree of Doctor
in Philosophy in Marriage and Family Therapy in the Graduate School of
Syracuse University

Syracuse University

December 2011

Copyright © Ileana Ungureanu 2011
All Rights Reserved

ACKNOWLEDGMENTS

First, I would like to thank my family for the ongoing and patient support throughout my long years of getting education. I thank you, Mom and Dad, for your unconditional support; I know that it is still unclear for you why I had to get a PhD on top of my other degrees... Even though it does not make too much sense, you were still there for me, encouraging me when I felt down, supporting me in countless ways. You are great parents! I also would like to thank my brother, Costin, and sister-in-law Codruta for being cheerleaders for me in this process. My nephew, Luca and niece, Maria, my two loves have been a source of great joy and relaxation, two much needed aspects when writing research-heavy pages. So, I thank them as well. Mimi, thank you for the love of knowledge you instilled in me from a very young age. I always knew you would be proud of me for getting as much education as I can. This thought motivated me throughout the years. I miss you...

A big thank you to my friends all over the world (Romania, Syracuse, Chicago, South Africa, England etc) who listened to my complaints, my whining and also excitement while writing this dissertation. And thanks to Skype for facilitating my communication with them...

I would like to thank the faculty in the Marriage and Family Therapy Department. They were always a source of inspiration and provided me with the support needed. Thank you, Linda for being such a great advisor, always ready when I needed clarifications, thorough and concise with your recommendations. I definitely could not have done it without your wise guiding. I would also like to thank all the members of my dissertation committee for the time and effort they put in the development of my dissertation.

A great 'thank you' to Dr. Zephon Lister for his invaluable help with the statistical analysis. A huge thank you for your great patience with me, buddy.

Last and most important, I will like to offer thanksgiving to my Heavenly Father. I strongly believe that all good things in my life came to be through Him. The present work is no exception.

TABLE OF CONTENTS

Abstract	i
Aknowledgments	v
Table of contents	vi
Chapter 1: Introduction	1
a. Purpose of the study	4
b. Specific goals	6
Chapter 2: Review of literature	7
a. Meet Emily	7
b. General aspects of the fibromyalgia syndrome	9
Definition and history of fibromyalgia	9
Diagnostic criteria	10
Other clinical features	11
Etiology	12
Genetic and environmental factors	13
Central pain processing	14
Hypothalamic-pituitary-adrenal axis dysfunction	14
Psychological factors	15
Treatment	17
Pharmacological treatment	17
Non-pharmacological treatment	18
c. The impact of fibromyalgia syndrome	20
Individual aspects	20
The process of diagnosis	21
The impact on daily life	22
Emotional impact	24
Interpersonal aspects	26
d. Alexithymia and fibromyalgia	30
Alexithymia: general aspects	30
Definition	30

Etiology	31
Interpersonal aspects	32
Alexithymia and health	34
Alexithymia and fibromyalgia	36
e. Couple satisfaction and fibromyalgia	42
f. Attachment theory	47
General aspects	47
Adult attachment	49
Attachment styles	50
Attachment and couple relationship quality	56
g. Alexithymia and attachment aspects	59
h. Attachment and chronic pain	64
Chapter 3: Methodology	69
a. Research design	69
b. Sample	69
c. Procedure	69
d. Measures	72
e. Analysis	75
Chapter 4: Results	80
a. Sample	80
b. Fibromyalgia Impact Questionnaire descriptive statistics	81
c. 20-item Toronto Alexithymia Scale descriptive statistics	82
d. Relationship Scale Questionnaire descriptive statistics	82
e. Revised Dyadic Adjustment Scale Questionnaire descriptive statistics	82
f. Structural equation modeling	83
g. Hypothesis 1	85
h. Hypothesis 2	87
i. Hypothesis 3	89
j. Hypothesis 4	92

Chapter 5: Discussion	94
a. Hypothesis 1	94
b. Hypothesis 2	97
c. Hypothesis 3 & 4	99
d. Who is Emily and how is this important for the findings of this study?	103
Gender, race and fibromyalgia	103
Aspects of education and class in fibromyalgia	105
population	
Relational characteristics	106
Chapter 6: Clinical implications and future research	108
a. Clinical implications	108
b. Limitations of the study	112
c. Future research	114
Appendices	117
a. Appendix A: Script for National Fibromyalgia Association site	117
b. Appendix B: Consent form	118
c. Appendix C: Fibromyalgia Impact Questionnaire	121
d. Appendix D: 20-item Toronto Alexithymia Scale	123
e. Appendix E: Relationship Scale Questionnaire	125
f. Appendix F: Revised Dyadic Adjustment Scale	127
g. Appendix G: Demographic Questionnaire	129
References	131
Curriculum Vitae	146

Chapter 1: INTRODUCTION

The fibromyalgia syndrome (FMS) is the most frequent cause of chronic, widespread pain and is estimated to affect 0.5% to 5.8% of people in North America and Europe (Hauser, Bernardy, Uceyler, & Sommer, 2009). FMS is second only to osteoarthritis as the most common cause of medical visits in rheumatology offices. FMS is a noninflammatory disease characterized by widespread pain and tenderness as well as fatigue, and nonrestorative sleep as the most frequent symptoms in which patients present. To date, there are no diagnostic tests for fibromyalgia. Rather, the American College of Rheumatology accepted criteria for diagnosis of the syndrome requires the spontaneous pain to be present for over 3 months along the spine in all four quadrants of the body, and pain upon digital palpation must be elicited in 11 out of 18 “tender points” (Wolfe, Yunus, Bennet, Bombardier, Goldenberg, Tugwell, Campbell, Abeles, Clark, Fam, Farber, Fiechtner, Franklin, Gatter, Hamaty, Lessard, Lichtbroun, Masi, McCain, Reynolds, Romano, Russel, & Sheon, 1990).

Even though not required as diagnostic criteria, individuals with a FMS diagnosis typically present with symptoms such as fatigue, subjective sleep disturbances, and “fibro fog” (difficulties with concentration and memory). In 20-40% of cases patients present also with an identifiable mood disorder such as depression and anxiety (Dadabhoy, & Clauw, 2008; Rao, Gendreau, Kranzler, 2007). FMS can result in severe disability despite the absence of “objective” laboratory findings (White, Specheley, Harth, & Ostbyte, 1999). With an estimated 2-4% of the population of the USA affected by this

condition, fibromyalgia has become a serious public health concern (Dadabhoy & Clauw, 2008).

FMS remains a controversial diagnosis more than 15 years after the establishment of the diagnostic criteria. It has been considered an unexplained medical condition, a psychosomatic illness or a functional somatic syndrome due to its more subjective clinical tableau than consistent tissue abnormalities. Recently, more empirical data has been accumulated on the etiology of this condition, even though there is no consensus among investigators on this subject. Two theories seem to have gained partisans in the medical community:

1. FMS is caused by abnormalities in the central pain processing
2. FMS is caused by a dysfunction of the hypothalamic-pituitary-adrenal axis.

Both research parties acknowledge the importance of the influence of genetic, environmental, and psychosocial factors on both the onset and progression of the syndrome.

The treatment for FMS is symptomatic, using both pharmacological and non-pharmacological methods. To date, the most used and accepted treatment protocol for FMS recommends a stepwise program emphasizing medical and psychological education, medication (e.g., anti-depressants, pain medication), exercise, and cognitive-behavioral therapy (Goldenberg, Burckhardt, & Crofford, 2004).

The research on the psychosocial aspects related to FMS has focused predominantly on the individual impact. Studies have been conducted on the process of diagnosis (Asbring & Narvanen, 2002; Cunningham & Jillings, 2006; Henriksson, 1995; Madden & Sim, 2006), the impact on daily life, and the emotional impact of the

syndrome (Affleck, Tennen, Urrrow, Higgins, Abeles, Hall, Karoly, & Newton, 1998; Arnold, Crofford, Mease, Burgess, Palmer, Abetz, & Martin, 2008; Cunningham & Jillings, 2006; Henriksson, 1995; Stuifbergen, Philips, Voelmeck, & Browder 2006). Interpersonal aspects have been investigated as well, with an emphasis on social network support, or coping strategies (Bolwjin, van Santen-Hoeufft, Baars, & van der Linden 1994; Bolwjin, van Santen-Hoeufft, Baars, Kaplan & van der Linden 1996; Arnold et al., 2008; Cunningham & Jillings, 2006; Henriksson, 1995; Stuifbergen et al., 2006), as well as on interpersonal stress (Murray, Murray, & Daniels, 2007). Little emphasis has been placed on the implications of FMS on couple or family functioning. Preece and Sandberg (2005) studied the concept of resilience in families with FMS, but to date very few studies addressed couple functioning when at least one partner is diagnosed with FMS (Bigatti & Cronan, 2002; Kool, Woertman, Prins, van Middendorp, & Geenen, 2006; Steinberg, 2007).

Fifteen percent of individuals with FMS present with alexithymia (Dadabhoy & Claw, 2008; Pedrosa Gil, Weigl, Wessels, Imich, Baumuller, & Winkelmann, 2008; Rao, Gendreau, & Kranzler, 2007), compared with the general population where alexithymia can be found in approximately 8-9% of males and 5% of females in a non-clinical population (Kokkonen, Karvonen, Veijola, Laksi, & Jokelainen, 2001; Posse, Hallstrom, & Backenroth-Ohsako, 2002). Alexithymia is a condition characterized by difficulties in identifying and describing feelings, as well as an externally oriented thinking (Bagby, Parker, & Taylor, 1994; Bagby & Taylor, 1997). Alexithymia has been found to have an important impact on the interpersonal relationships. Very few studies, however, have been conducted on the specific features of alexithymia in the fibromyalgia population

(Brosshot & Aarse, 2001; van Middendorp, Lumley, Jacobs, van Doornen, Bijlsma, & Geenen, 2007; Pedrosa Gil et al., 2008).

Moreover, patients with FMS seem to employ avoidant behaviors as strategies for coping (Brosshot & Aarse, 2001; Bolwjin et al., 1994; 1996; van Middendorp et al., 2007), and only two studies looked at the attachment style in fibromyalgia samples (Hallberg, Lillemor, Carlsson, 1998; Steinberg, 2007). Marital satisfaction is another variable that has only scarcely been investigated in this population (Chenhall, 1999).

To the best of my knowledge, no studies have been conducted on the relationship between alexithymia, marital satisfaction, and attachment style in people with fibromyalgia. It is my assertion based on the reviewed literature that the couple relationship may suffer when at least one of the partners struggles with FMS chronic pain, presents alexithymic features, and/or is insecurely attached.

Purpose of the study

The purpose of this dissertation study was to investigate the interrelation between alexithymia and attachment style for fibromyalgia patients, and their impact on marital quality.

Fibromyalgia takes its toll on the couple relationship through several of its characteristics. The literature reviewed shows that the ambiguity of the medical community about the etiology and the treatment of the syndrome leave individuals and their families with few ways to help alleviate the suffering. Unfortunately, the absence of medically objective findings can generate disbelief about the veracity of the symptoms for both family members and, at times, health care providers. This disbelief can have a particularly negative impact on the couple relationship. Even a supportive spouse can

have difficulties sustaining support in the face of a little understood condition as one of the participants in Henriksson's (1995) qualitative study reveals: "He's supportive, he knows he wants to be supportive but... it's really hard for him because our lives have changed... we've had some real tough times through this/.../ I think he has more to learn about it, he's not a very patient man, so it's been hard/.../ sometimes I think it would be a lot easier to do this alone..." (p.71).

The unpredictability of the symptoms makes it difficult for the couple to plan activities together and the entire family is impacted. The intense pain and fatigue can be debilitating and sometimes people with FMS are forced to reduce substantially or even quit working, creating a financial strain. In this situation, the well spouse may be forced to work more as a sole provider in addition to having to take on more of the household work that used to be the responsibility of the now ill spouse.

Given these circumstances, the couple relationship may be under a lot of stress. In addition, the sexual aspects of the relationship may suffer due to pain and fatigue and also an emotional unavailability that can be a result of these symptoms. In other situations, alexithymic features of the FMS suffering individuals and/or an insecure attachment style may contribute to marital distress and dissatisfaction. When these aspects come into play patients may believe as Henriksson's study (1995) participant stated: "sometimes I think it would be a lot easier to do this alone". Not only may the quality of the relationship suffers, there is a risk of relationship dissolution, which may deprive the ill spouse of support needed to fight fibromyalgia.

I investigated the quality of the marital relationship for people with fibromyalgia. Results stemming from such an inquiry may include the following: adding a more in-

depth understanding of the interpersonal transaction of this population; adding knowledge about the quality of the marital relationship in people suffering from FMS; advancing the knowledge of the interplay between alexithymia and adult attachment style in general; adding more information about the influence of alexithymic features and/or an insecure attachment style in the fibromyalgia population; and helping clinicians have a better understanding of the syndrome and its impact on the marital relationship in order to assist their clients to successfully manage FMS symptoms.

Specific goals

Goal 1:

To investigate the impact of fibromyalgia symptoms on the couple relationship.

Goal 2

To investigate the relationship between the adult attachment style and marital satisfaction when at least one partner is diagnosed with FMS.

Goal 3

To investigate the relationship between alexithymic features and marital satisfaction when at least one partner is diagnosed with FMS.

Goal 4

To assess the interplay of FMS symptoms, alexithymia, and adult attachment on the quality of couple relationship in fibromyalgia population.

Chapter 2: REVIEW of LITERATURE

Meet Emily

As mentioned earlier, this is a quantitative study of the impact of fibromyalgia symptoms on the couple relationship. As with all quantitative studies, it is hard to picture the people behind the numbers, who are they, how the chronic pain and fatigue impact their daily lives and their intimate relationships. In order to make the participants in my study more visible, I decided to introduce Emily to you.

Emily*, a 43-year old woman presents to her Primary Care Provider (PCP) with complaints such as pains all over her body, muscle stiffness, extreme fatigue, and memory loss. All these symptoms are worse in the morning, and improve in the early afternoon. The pain is the worst in her shoulder and neck, and quite intense in the knees, hips, elbows, and is worsened by the weather change or increased physical activity. It awakens her more than three times at night, and her husband complains that her constant moving around in bed disturbs his sleep. She previously worked full-time as a high school guidance counselor. She used to teach Sunday school, and was able to take long family bike rides and was involved in charity work at church. Emily has three children, ages 5, 8, and 12. She had to cut back to half-time at work one year ago due to pain and fatigue.

Emily's daily living activities are limited now. She has difficulties combing her hair because of the shoulder and elbow pain. Due to neck pain, she has difficulty turning her head while driving. Lately, she is unable to do the shopping and vacuuming and it is more and more difficult to keep up with her 5-year old daughter. Both Emily and her

* This case-scenario is not factual. It is a didactic synthesis meant to serve the purpose of this dissertation; it was inspired by personal conversations with FMS patients as well as cases reported on the American College of Rheumatology web-site (www.rheumatology.org).

husband are concerned that very soon their youngest child will not be safe at home alone with her. There are tensions in the couple because of the changes in the roles within the family. Her husband seems overwhelmed by having to work full-time, taking care of the house chores, making sure the children are safe and happy, and tending to a wife in constant pain. Moreover, since the pain worsened their sexual life has suffered, because it hurts Emily when she is touched. Unfortunately, Emily's husband doubts that the pain has the intensity his wife claims and says "she just wants to avoid sex". He seems to lack the understanding of the impact of her symptoms. She is very distressed by the progressing pain and activity limitations and feels she has lost control over her life. She is very concerned about her marital relationship and fears her husband will soon leave her. She does not feel she can talk to him about her symptoms and fears.

Emily is desperately looking for help as she sees her life is totally out of control and she feels at a loss intervening by herself. She tried over-the-counter Ibuprofen and Acetaminophen but these agents have not been helpful. She is now on a low dose antidepressant to help her with her sleep. All lab results are normal. Physical examination reveals that the range of motion (ROM) is within functional limits except for her neck and shoulder where ROM is limited to 50%, with pain occurring at overhead motions. Emily winces and withdraws to moderate pressure applied bilateral to the suboccipital region, the midpoint of the trapezi, the superior lateral quadrant of the buttocks, the greater trochanteric region, the second costochondral region, the lateral epicondyle, and around the medial aspect of the knee. This classifies her as positive in 14 out of 18 tender points, a diagnostic criterion of fibromyalgia syndrome (FMS).

Emily presents us with a common case scenario for FMS. Her struggles to keep a normal life can be considered every day struggles for people diagnosed with this chronic pain syndrome. In addition to their individual fighting of the disease, FMS patients' lives are affected in the relational, marital, family, and social aspects. Emily feels threatened that her husband is going to leave her and the children because of the constant pain and fatigue. Moreover, he seems to distrust the reality and intensity of her symptoms. She found solace in the FMS diagnosis, knowing that this is really happening to her, it is "not only in her head". However, her primary care physician (PCP) told her there is no cure for it; she will have to deal with the syndrome for the rest of her life with the help of pain medication, and some exercise. Also, the PCP mentioned psychotherapy if things are not changing with her husband.

General aspects of the fibromyalgia syndrome

Definition and history of fibromyalgia

FMS is the most frequent cause of chronic, widespread pain in the USA (Cymet, 2003; Dadabhoy & Clauw, 2008; Okifuji & Turk, 1999; Rao, Gendreau & Kranzler, 2007). It is a non-inflammatory musculoskeletal syndrome predominantly found in the female middle-aged population. For every one man diagnosed with FMS, four females are diagnosed (Dadabhoy & Clauw, 2008; Mease, 2008). The world-wide prevalence is estimated as ranging from 0.5% to 5% of the general population. In the United States, FMS affects 2-4% of the total population, approximately 6-12 million Americans (Dadabhoy & Clauw, 2008; Mease, 2008; Rao, Gendreau & Kranzler, 2007). FMS patients represent 5-6% of the general practice patients and 10-16% of the rheumatology

practice patients (Mease, 2008). This syndrome is diagnosed amongst all socio-economic classes in countries all over the world, and in all types of climates (Cymet, 2003).

Patients with FMS are high utilizers of health care. They see their PCP anywhere from 10-22 times a year and are admitted in the hospital for their symptoms once every three years (Cymet, 2003). The condition can be debilitating and can cause patients to reduce their work-load or even quit work all together.

The first case of muscular pain that limits activity of unknown origin was reported in 1736 by Guillaume de Baillou in his *Liber de Rheumatismo*, a case that is currently accepted as consistent with the diagnostic criteria of fibromyalgia (Cymet, 2003). In 1904, Gowers coined the term *fibrositis* to describe a musculo-skeletal condition of unknown etiology, but the medical community did little to advance knowledge of the condition for many years (Cymet, 2003; Mease, 2008). Until 1990, the name of the syndrome changed several times from pressure point syndrome, myofasciitis, muscular rheumatism, neuromyasthenia, myofascial pain syndrome, to fibrositis. In 1977, Smythe and Moldofsky were amongst the first physicians to propose diagnostic criteria for FMS and eventually in 1990, a multicenter committee of the American College of Rheumatology established the diagnostic criteria and coined the name of the syndrome in fibromyalgia (Wolfe et al., 1990).

Diagnostic criteria

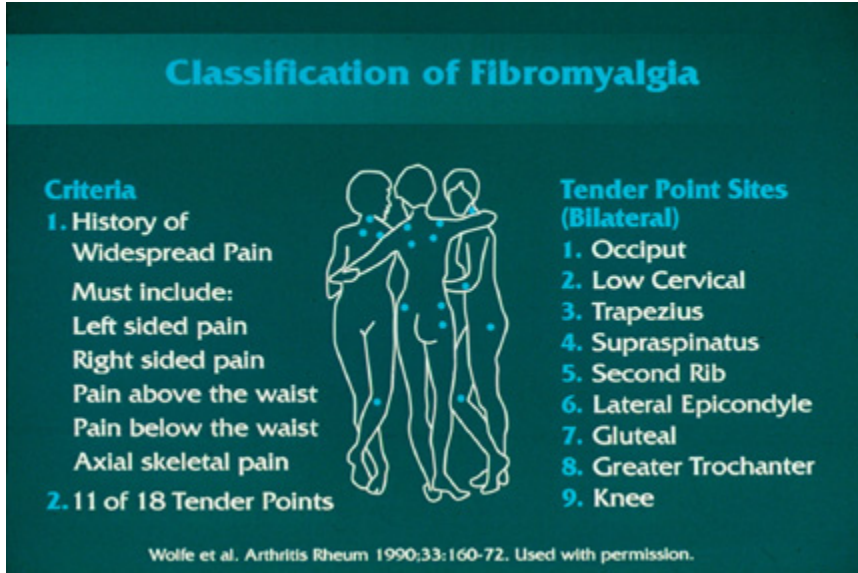

Figure 1: Diagnostic criteria for Fibromyalgia

Currently, the American College of Rheumatology (ACR) diagnostic of fibromyalgia requires that spontaneous pain be present for at least 3 months along the spine and in all four quadrants of the body in over 11 of 18 tender points as seen in Figure 1 (Wolfe et al., 1990). The members of the ACR committee highlighted that these criteria were never intended as diagnostic criteria for individual patients but rather as a general frame to help clinicians in their diagnostic attempts. As a result, almost half of the individuals who have the diagnosis do not fulfill the aforementioned criteria (Dadabhoy & Clauw, 2008).

Other characteristic clinical features

Even though not included in the ACR diagnostic criteria, there are other important clinical features of FMS that are present in the majority of patients (Cymet, 2003; Dadabhoy & Clauw, 2008; Mease, 2008; Rao, Gendreau & Kranzler, 2007). Patients with FMS show abnormalities in pain perception, in the form of both allodynia – pain even

from a non-painful stimulus, and hyperalgesia – pain is perceived with a higher intensity than would be by a non-FMS volunteer (Rao, Gendreau, & Kranzler, 2007).

The second most important symptom besides widespread pain, found in the vast majority of the FMS patients, is fatigue. Often times, fatigue constitutes the source of disability and activity limitations in these patients. Approximately three-quarters of the patients are affected by sleep disturbances, especially in the form of non-restorative sleep (Cymet, 2003; Dadabhoy & Clauw, 2008; Mease, 2008; Rao, Gendreau & Kranzler, 2008). Morning stiffness and migraine headaches are other characteristic features of this syndrome. A certain degree of cognitive impairment can be present. Patients complain of memory loss, and difficulties with concentration, a situation that has been called “fibro fog” and is one of the most bothersome symptoms (Cymet, 2003; Rao, Gendreau, & Kranzler, 2008). In addition, FMS patients have impaired social and occupational functioning (Cymet, 2003; Dadabhoy & Clauw, 2008; Mease, 2008; Rao, Gendreau & Kranzler, 2008).

The pain as well as other associated symptoms such as fatigue, sleep disturbances, and the “fibro fog” are present daily in the life of FMS patients. It is generally accepted that these symptoms are aggravated by rapid change in temperature, cold and humid weather, and especially stress (Cymet, 2003).

The most frequent comorbid disorders are depression and anxiety, which are present in 20-40% of the patients (Arnold et al., 2006; Dadabhoy & Clauw, 2008; Rao, Gendreau & Kranzler, 2007). The frequency of these comorbid disorders has led to a debate in the medical community about whether FMS is actually a psychiatric disorder that is related to depression, rather than a musculoskeletal disorder (Alfinci, Sigal, &

Landau, 1989). Other important comorbid symptoms and syndromes are: irritable bowel syndrome, temporomandibular joint dysfunction, interstitial cystitis, chronic fatigue syndrome, nondermatomal paresthesias, idiopathic low back pain, multiple chemical sensitivities, and noncardiac chest pain (Arnold et al., 2006; Cymet, 2003; Dadabhoy & Claw, 2008; Mease, 2008; Rao, Gendreau, & Kranzler, 2007).

Etiology

The etiology of fibromyalgia is relatively unknown. A number of attempts have been made to clarify the mechanisms that can explain its symptoms. Initially, FMS was believed to be an inflammatory, rheumatologic condition that affects joints and muscles. Due to the diffuse musculoskeletal pain, FMS was then believed to be caused by alterations in the muscle structure and metabolism (Mengshoel, Forre, & Komnaes, 1990). These peripheral hypotheses failed to explain the diffuse and generalized nature of pain in FMS. Currently, it is believed that FMS involves central mechanisms, and that the syndrome has a multi-factorial pathogeny (Dadabhoy & Claw, 2008; Mease, 2008; Okifuji & Turk, 1999; Rao, Gendreau, & Kranzler, 2007; Simon, 2008).

Recent research has shown that there are multiple mechanisms involved in the pathophysiology of FMS: genetic and environmental factors, central pain processing abnormalities, hypothalamic-pituitary-adrenal axis (HPA) disturbances, and psychological factors. The role of the muscular pathology has largely been discarded (Mease, 2008; Rao, Gendreau, & Kranzler, 2007).

Genetic and environmental factors

There is increasing evidence that supports the hypothesis of a genetic predisposition to FMS. The odds ratio for first degree relatives is higher than eight in FMS (Arnold et al, 2004). The genes that were found relevant in this process are: serotonin-transporter, dopamine-D-receptor, and catecholamine-O-methyltransferase. Dadabhoy and Claw (2008) highlighted that “notably, these polymorphisms all affect the metabolism or transport of monoamines, compounds that have a critical role in both sensory processing and the human stress response” (p. 90), suggesting that stress may have an important role in the pathophysiology of this syndrome.

In addition, many patients can relate the debut of FMS with some undercurrent stressors such as physical and/or emotional trauma (for i.e., car accidents, sexual assault), certain infections (for i.e., hepatitis C virus, Lyme disease), or other autoimmune disorders (Dadabhoy & Claw, 2008; Mease, 2008; Okifuji & Turk, 1999; Rao, Gendreau, & Kranzler, 2007). All of the disorders mentioned above are known to be influenced by the body’s stress reactions, making it more susceptible to develop the conditions mentioned or prolonging the healing process.

Central pain processing

Research has consistently demonstrated that FMS patients show a lower pain threshold than do control groups of non-FMS patients. It is not that FMS patients perceive pain at lower levels than control groups, it is that the point at which stimuli can cause pain is much lower (Kosek, Ekholm, & Hansson, 1996; Okifuji & Turk, 1999). FMS patients also seem to have a slower recovery from induced pain than their non-FMS counterparts (Kosek & Hansson, 1997). The medical community agrees that there are at

least two aspects of the pain processing that occur with FMS patients: central pain amplification, and a decreased descending analgesic activity (Dadabhoy & Claw, 2008; Mease, 2008; Okifuji & Turk, 1999).

Hypothalamic-pituitary-adrenal axis dysfunction

The HPA axis serves as a link between a stressor, such as pain, and the individual's endocrine, autonomic, and behavioral response. The findings of research on the HPA axis in FMS patients reveals lower basal cortisol levels than are found with healthy individuals, as well as abnormal reactivity to stressors (Crofford, Engleberg, & Demitrack, 1996). To date, the results of studies attempting to determine the specific HPA role in FMS have been confusing; the HPA dysfunction is not specific to fibromyalgia and may be more related to decreased mobility and negative affect than to generalized pain (Okifuji & Turk, 1999; Rao, Gendreau, & Krauzler, 2007).

Psychological factors

Due to the high prevalence rate of depression and anxiety in FMS patients some researchers hypothesized that the mood disorder was the mechanism underlying the syndrome. Alfici, Sigal, and Landau (1989) hypothesized that individuals can develop depressive disorders that are expressed somatically rather than emotionally in the form of pain. They considered FMS as a variant depressive disorder. Currently, this hypothesis has largely been debunked due to insufficient support through consequent studies (Okifuji & Turk, 1999).

Multiple studies have shown that an important percentage of female FMS patients have a history of being sexually assaulted implying a cause –effect relationship between sexual abuse and FMS (Van Houdenove & Egle, 2004; Boisset-Pioro, Esdaile, &

Fitzcharles, 1995; Taylor, Trotter, & Csuka, 1995). More recent studies support the idea that stress processing may play an important role in the development of FMS symptoms rather than a cause-effect relationship model. These researchers argue that individuals with a history of trauma have an increased risk to develop FMS, PTSD, and mood disorders due to a dysregulation of the physiological stress response, which can induce stress vulnerability and chronic stress that may function as mediators for the onset of FMS symptoms (Ciccone et al., 2005; Raphael, 2006; Seng, Clark, McCarthy, & Ronis 2006).

Dadabhoy and Claw (2008) suggested that in FMS, as well as in other rheumatic diseases there is interplay between pain and stress in which pain leads to stress and stress can lead to pain. “Pain and other symptoms of FMS may cause individuals to function less well in their various roles. They might have difficulties with family members and co-workers, which exacerbate symptoms and lead to maladaptive illness behavior such as cessation of pleasurable activities and reductions in activity and exercise” (p. 91).

In summary, there are not yet very explicit pathways to explain the underlying mechanisms of FMS symptoms. It seems that the central pain processing hypothesis has received the most support in later studies, and the stress component is viewed as a mediator rather than the cause of the syndrome. The multifactorial origin and the role that the environment seems to play in the maintenance of symptoms place FMS among the biopsychosocial disorders (Engel, 1977). Rao, Gendreau, and Kranzler (2007) proposed a model (see figure 2) where “in susceptible individuals, all of the symptoms and findings are reciprocally interconnected, and abnormalities in one element would ultimately result in perturbations in the others” (p. 39).

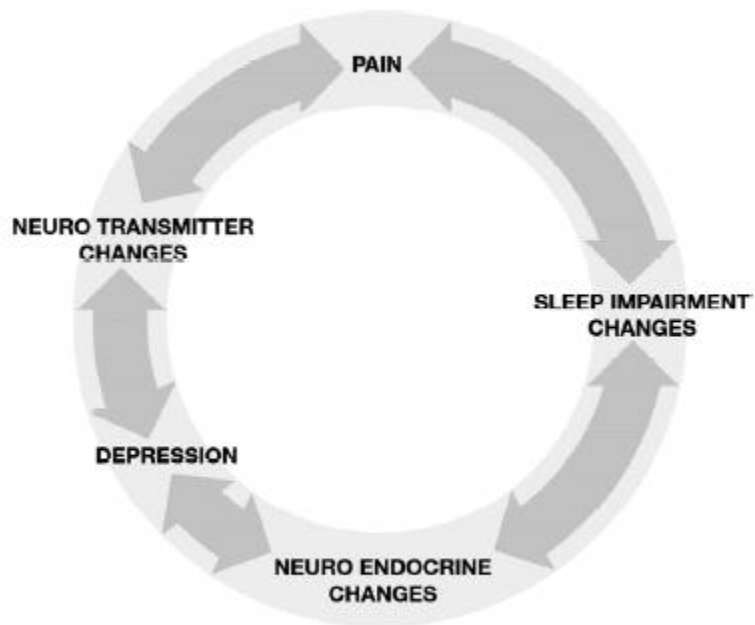

Rao, Gendreau, and Kranzler. *Psychopharmacology Bulletin*. Vol. 40. No. 4. 2007.

Source: Psychopharmacol Bull © 2007 MedWorks Media Global

Figure 2: The interdependence of symptoms and findings in FMS

Treatment

A variety of therapeutic modalities are used to treat FMS, both pharmacological and non-pharmacological. With progress in the understanding of this syndrome, treatment options improve over the time.

Pharmacological treatment

Currently, the most used pharmacological agents are antidepressants, analgesics and muscle relaxants, and anticonvulsants (Dadabhoy & Claw, 2008; Goldberg, Burckhardt, & Crofford, 2004; Mease, 2008; Okifuji & Turck, 1999; Rao, Gendreau, &

Kranzler, 2007). The antidepressant with strongest evidence for efficacy is amitriptyline which seems to improve sleep and overall well-being. For serotonin-reuptake and dual-reuptake inhibitors investigators were able to find only modest evidence for efficacy. Analgesics and muscle relaxants such as cyclobenzaprine and tramadol were proved to be very efficacious and to improve pain, as well as sleep (Goldberg, Burckhardt, & Crofford, 2004).

Evidence from a very recent meta-analysis (Hauser et al., 2009) of 18 randomized controlled clinical trials of antidepressants in the treatment of FMS shows that these drugs can improve pain, fatigue, sleep disturbance, and health-related quality of life. However, the authors recommend that before treatment is initiated, potential adverse effects from the drug should be considered, and alternate treatments such as psychotherapy or balneotherapy (treatment with baths) should be discussed with patients.

Non-pharmacological treatment

A large variety of non-pharmacological therapeutic options are used, such as: education, cardiovascular exercise, massage, chiropractic practice, balneotherapy, alternative medicine practices (acupuncture, elimination diet, magnetic therapy, zone therapy, pet therapy), cognitive-behavioral therapy, biofeedback, and hypnotherapy (Cymet, 2003; Dadabhoy & Claw, 2008; Goldberg, Burckhardt, & Crofford, 2004; Mease, 2008; Okifuji & Turck, 1999; Rao, Gendreau, & Kranzler, 2007).

Cardiovascular exercise has been shown to be effective in minimizing FMS symptoms as long as the person continues to exercise (Gowans et al., 1999; Goldbeg, Burckhardt, & Crofford, 2004). Efficacy is not maintained if the exercise stops. Patient education and cognitive-behavioral therapy (CBT), on the other hand, have both been

shown to show improvements that are sustained for months after the ending of the sessions (Goldberg, Burckhardt, & Crofford, 2004).

CBT for FMS patients basically refers to a “structured education program that focuses on teaching individuals skills that they can utilize to improve their illness” (Dadabhoy & Claw, 2008, p.92) such as relaxation and visual imagery techniques, focal point and visual distraction, cognitive restructuring, problem solving, and goal setting. Reviews have confirmed that CBT improved pain, fatigue, mood, and function (Williams, 2003; Rossy et al., 1992).

Turk, Okifuji, Sinclair, and Starz (1996) classified FMS patients in three groups based on their cognitive-behavioral responses to their symptoms: dysfunctional, interpersonally distressed, and adaptive copers. A subsequent study of the same investigators showed that treatment responses varied greatly across subgroups (Turk, Okifuji, Starz, and Sinclair, 1998). Individuals that were labeled “dysfunctional” with high levels of pain, poor coping, emotional distress, and perceived disability benefited most from CBT, “whereas those whose distress and disability were associated with their interpersonal problems did not improve, suggesting that an additional treatment component addressing the interpersonal issues may be needed” (Okifuji & Turck, 1999, p. 242) for this group of patients.

To date, only one study addressed couple therapy in the treatment of FMS patients. The authors assessed the effectiveness of two modalities of treatment: group psychomotor therapy and marital counseling (de Voogd, Knipping, de Blecourt, & van Rijswijk, 1993). The study failed to show significant differences between the two groups.

However, the attrition rate in this project was high (34%), which may limit the generalizability of the results.

There is strong evidence for the efficacy of multidisciplinary treatment in FMS. It seems that a combination of exercise, education, and CBT can significantly improve the well-being of patients, decrease the levels of pain, and improve sleep (Goldberg, Burckhardt, & Crofford, 2004; Gowans, Dehueck, Voss, & Richardson 1999; Okifuji & Turck, 1999; Rossy, Buckelew, Dorr, Haglund, Thayer, McIntosh, Hewett, & Johnson 1999). Rao, Gendreau, and Kranzler's model (2007, see Figure 2) seems to plead for the importance of addressing multiple symptoms by a multidisciplinary team of professionals. It appears that it is less likely that treating symptoms in isolation will be effective in treating the syndrome.

The impact of fibromyalgia syndrome

Individual aspects

Fibromyalgia affects an individual's whole biopsychosocial situation and becomes a health problem for society in general. For Emily in the vignette above, the chronic pain she had to fight every day affected her personally and interpersonally as well. In addition to the constant pain and the changes she had to make in her job, she could not be the mother, wife, or co-worker she used to be. Fibromyalgia is both an *illness* and a *disease* (Kleinman, 1988) as are other chronic disorders. In his ethnographic study on suffering and healing, Kleinman (1988) defines *disease* from a medical perspective: "Disease is what the practitioner creates in the recasting of illness in terms of theories of disorder. Disease is what the practitioners have been trained to see through the theoretical lenses of their particular form of practice" (p. 5). On the other hand, *illness*

“refers to how the sick person and the members of the family or wider social network perceive, live with, and respond to symptoms and disability” (p. 3). In this study fibromyalgia will be discussed as both with an emphasis on its *illness* aspects.

The process of diagnosis

The diagnostic process in the FMS is different than for other chronic diseases. Not long ago, the cluster of symptoms coined today as fibromyalgia were considered a non-diagnosis or at the best a psychosomatic disease, more of a variance of depression or related to a personality disorder than a medical entity. The pain or the intensity of pain is a subjective experience that is hard to quantify. The interplay between the two concepts (Kleinman, 1988), *illness/disease*, is apparent for these individuals, their suffering not being sustained by lab works or other types of medical investigations.

Many fibromyalgia patients report lengthy contacts, often for many years, with health care providers before they are diagnosed. In qualitative studies, this time is described as very difficult, the patients felt they were referred from one specialist to another, sometimes in extreme pain, while the medical community was unable to provide any relief (Asbring & Narvanen, 2002; Cunningham & Jillings, 2006; Henriksson, 1995; Madden & Sim, 2006). This period was described as one of intense anxiety, when hope for a tangible diagnosis was changed into a sense of hopelessness (Henriksson, 1995; Madden & Sim, 2006).

Another common reaction from health care providers as well as family and friends is disbelief (Asbring & Narvanen, 2002; Cunningham & Jillings, 2006; Henriksson, 1995; Madden & Sim, 2006). In his qualitative study of 40 women with fibromyalgia, Henriksson (1995) found that the “contradiction between one’s own

perception of pain and fatigue and the inability of the medical specialists to find any proof of disease is experienced as very frustrating, and even degrading. The patients experience lack of interest and empathy, or disbelief” (p. 70). Some of the participants in this study questioned the reality of their symptoms and therefore their mental sanity after being repeatedly told there is nothing wrong with them.

Being diagnosed with FMS brought a sense of relief for a majority of individuals (Asbring & Narvanen, 2002; Cunningham & Jillings, 2006; Henriksson, 1995; Madden & Sim, 2006). Their suffering became real and visible for the health care providers, family, friends, and co-workers. It helped them personally verify the truthfulness of their experience.

For others, the scientific community’s ambiguity that is still associated with the diagnosis of FMS, the lack of understanding of its pathogeny and a treatment that is not yet completely effective, does not provide the relief expected. Also, FMS is not very well known to the larger public, it is not public knowledge in the same way asthma or diabetes are. Thus, it fails to give a common language to explain the illness to family, friends, and co-workers, having a negative influence on FMS patients’ relationships. (Madden & Sim, 2006; Asbring & Narvanen, 2002).

The impact on daily life

In the clinical vignette presented above, Emily complained to her PCP about the extent of the impact FMS has had on her daily routines. She has difficulties taking care of herself and others in her family: combing her hair is a challenge because of the shoulder and elbow pain. Due to neck pain, she has difficulty turning her head while driving, she is unable to do the shopping, vacuuming and it is more and more difficult to keep up with

her 5-year old daughter. Both Emily and her husband are concerned that very soon her youngest child will not be safe at home alone with her. There are tensions in the couple because of the changes in the roles within the family. Emily had to reduce her time at work from full-time to part-time due to pain and fatigue, and renounce other activities that were enjoyable before (e.g., taking long bike trips with her husband and children). Research has shown that Emily's case is typical for patients with FMS.

Studies of the impact of the syndrome on daily lives revealed that individuals had difficulties performing household chores such as grocery shopping, housecleaning, or even self-care routines (e.g., showering) due to pain, fatigue, loss of energy, and depression symptoms (Affleck et al., 1998; Arnold et al., 2008; Cunningham & Jillings, 2006; Henriksson, 1995; Stuifbergen et al., 2006). Some research studies found that patients diagnosed with FMS could no longer pursue athletic-type of leisure activities such as jogging, bicycling, or pursue hobbies that they previously enjoyed. This forced renunciation of enjoyable activities contributed to the maintenance of depression symptoms (Arnold et al., 2008; Henriksson, 1995; Stuifbergen et al., 2006).

Participants in such research studies reported their careers and jobs being severely affected by their suffering. Some had to frequently change jobs, or drastically reduce the work hours due to pain, fatigue, difficulties with concentration and memory problems. In Arnold et al's (2008) study, half of the participants had to quit their jobs altogether, renouncing well-established careers and having to endure the financial and emotional repercussions of such decisions. In the same study, some participants reported having to quit pursuing higher education because of the inability to focus, and fatigue.

Henriksson (1995) describes two additional aspects of the impact on life of individuals with FMS: time-use and loss of future. Participants in his qualitative study of forty women with fibromyalgia reported a change in their time use: every activity they have to perform takes more time, the pace is slower, and they are not able to do the same amount of things they used to do in a day. Another aspect Henriksson describes is the loss of future. “The women are disappointed over their lost future: not being able to experience the satisfaction of physically demanding leisure activities, of taking a degree, or advancing in one’s chosen profession. Not being able to choose freely, but always having to consider the limitations that the symptoms impose on life” (p. 74).

One study assessed the daily impact of FMS symptoms on the pursuit of personal goals (Affleck et al., 1998). Fifty women were monitored for thirty consecutive days on how the pain, fatigue and non-restorative sleep affected their goal progress in two main areas: health/fitness (for example, maintain exercise routine, eat healthy, quit smoking) and social/interpersonal (for example, be more patient with co-workers, be less critical with spouse). The analysis of the day-to-day data showed that pain, fatigue and non-restorative sleep the night before predicted the following day’s ability to pursue the health/fitness goals, but not the interpersonal ones. However, on further analysis Affleck et al. (1998) found that women who reported more progress in their interpersonal goals also reported increase in positive mood, which was found to be an indirect pathway to improving FMS symptoms.

Emotional impact

Twenty-four percent of patients with FMS suffer with depression and anxiety, which are the most frequent comorbid disorders (Arnold, Hudson, Keck, Auchenbach,

Javaras, & Hess 2006; Dadabhoy & Claw, 2008; Rao, Gendreau & Kranzler, 2007).

Some patients also report panic attacks and/or levels of depression that are disruptive to their lives. Patients with FMS seem to describe either clinical depression or a mood condition that is secondary to living with constant pain and fatigue (Arnold et al., 2006; Cunningham & Jillings, 2006; Henriksson, 1995).

In addition to depressive and anxiety symptoms, FMS patients report feelings of frustration, embarrassment/stigma, shame, and guilt. They are frustrated with their inability to perform daily activities as they used to over their loss of cognitive abilities or loss of sexual intimacy. There is also a sense of guilt associated with having to burden their spouses or other members of the families with those things that they are no longer able to perform (Arnold et al., 2006; Henriksson, 1995; Kelley, 1998). The feelings of embarrassment, stigma, and shame are primarily related to the difficulty in being understood by health care providers, family, friends and co-workers (Arnold et al., 2006; Asbring & Narvanen, 2002; Henriksson, 1995; Stuifbergen et al., 2006).

Asbring and Narvanen's (2002) qualitative study of 12 women with chronic fatigue syndrome and 13 with fibromyalgia revealed that the participants experienced their morality questioned in interaction with others and also their suffering psychologized, especially by physicians. The diagnosis itself was a relief for some participants and a burden for others because of the ambiguity of the diagnosis. Strategies used by the women in this study in dealing with the stigma were keeping a distance from others, concealing, spreading and/or withholding information, withdrawing from and/or approaching patients with the same diagnosis.

Interpersonal aspects

The social life of fibromyalgia patients is deeply affected through their decreased ability to establish and maintain emotional and physical contact with those close to them. Participants in several qualitative studies (Arnold et al., Cunningham & Jillings, 2006; Henriksson, 1995; Stuifbergen et al., 2006) described that they lost friendships because they were unable to participate or even to plan social events because they could not anticipate how they would feel. They preferred to not make plans instead of being perceived as unreliable. Some of the fibromyalgia patients have to face doubt and reluctance from their co-workers, who do not believe they are in such pain that they have to reduce their work load, losing relationships with them.

Henriksson (1995) highlights another reason for the loss of social contact in patients with FMS: *disidentification*. “As a protective mechanism, persons in the surroundings might distance themselves from the person with pain, show lack of empathy, and even rejection” (p. 72). This can result in a decrease in the close social relationships for fibromyalgia patients.

The social network of people with fibromyalgia was found to be smaller than those of people diagnosed with other chronic pain condition like rheumatoid arthritis or healthy control groups (Bolwijn et al., 1994; Bolwijn et al., 1996). It seems that FMS patients rely more on their spouses and intimate friends, and networks that are geographically close to them. Bolwijn et al. (1994, 1996) noticed that patients with fibromyalgia lacked initiative to develop new friendships or maintain already existing relationships. On the other hand, increased social support was found to lessen symptoms of pain, fatigue and sleep disturbances in patients with fibromyalgia (Feldman, 2007;

Preece & Sandberg, 2005). Thus, interventions that help people with FMS to increase their social networks may be effective in decreasing the symptoms.

When compared with other chronic pain patients (for example, osteoarthritis), FMS patients reported poorer emotional and physical health, smaller social networks, and more frequent use of avoidant strategies in social interactions (Davies, Zautra, & Reich, 2001; Zautra, Hamilton, & Burk, 1999). Furthermore, these patients reported lower levels of perceived support which enhanced their experience of social conflict and in turn activated avoidant coping strategies.

Steinberg's (2007) qualitative study on the experience of relationships showed that only approximately 15% of the participants were able to maintain a long term intimate romantic relationships. Romantic relationships seemed to be too anxiety-charged and it was "safer to maintain an active internal fantasy world than to handle the anxiety triggered by real human contact. Some of the lower functioning respondents in this study live in almost complete isolation" (p. 78). Anxiety and stress is known to increase the level of pain and worsen other symptoms in FMS (Murray, Murray, & Daniels, 2007; Preece & Sandberg, 2005). Several participants in this study reported that while being in intimate relationships their FMS symptoms worsened. It can be implied that the anxiety related to intimacy may increase the pain and other symptoms of FMS triggering avoidant behaviors.

As stated above, family relationships are affected by fibromyalgia symptoms. Patients report having to reduce the time spent with family members, not being able to care for their children in the way they were able to before having fibromyalgia symptoms. The other adult members of the family have to take over the chores that the ill

member cannot manage anymore. This creates tension in the couple relationship for some patients with FMS (Arnold et al., 2006; Henriksson, 1995; Stuijbergen et al., 2002).

Furthermore, “problems in the relationship are reported by the participants to exacerbate symptoms such as sleep disorders and pain” (Henriksson, 1995, p. 71), which in turn creates more problems in the relationship.

Perceived interpersonal stress in the family was found to be the predictor variable that accounted the most for the variance associated with fibromyalgia symptoms (Murray, Murray, & Daniels, 2007). Researchers investigated the influence of stress and family functioning, measured by differentiation of self, on the severity of symptoms in FMS. The findings showed that participants’ level of symptoms’ intensity could be predicted by their level of differentiation, suggesting that family functioning and the level of stress in the family has an important impact on the quality of life of people with FMS.

While some studies show lack of support by family members of people with FMS, other studies show that FMS patients report receiving the support and understanding they need from relatives and friends. Family members trying to understand and gathering knowledge of what it means to live with muscular pain, is greatly appreciated by patients and contributes to developing empathy (Henriksson, 1995). The types of support patients report receiving in the family is represented by practical help with daily activities, emotional support, and taking over the role of the ill member in the family (Hallberg & Carlsson, 1998).

Preece and Sandberg’s (2005) study of 150 fibromyalgia patients showed that family hardiness and social support are associated with a decrease in health problems and functional disability. The same study revealed that family stressors and strains were

positively associated with the frequency of medication use. The researchers highlight the importance of family support and resilience as well as the importance of family therapy interventions in the management of FMS.

Fibromyalgia symptoms seem to have an impact on the well-being of spouses of FMS patients. In a study of 135 spouses of FMS patients who were compared with 153 spouses of healthy individuals, the FMS group reported lower physical and emotional health states and scored higher on depression and subjective perception on stress than their healthy counterparts (Bigatti & Cronan, 2002). Fibromyalgia, like other chronic pain conditions seems to impact the health of the entire family system not only the sufferer.

One of the most important interpersonal losses reported by participants in research studies is related to changes in sexuality (Arnold et al., 2006; Cunningham and Jillings, 2006; Henriksson, 1995; Kelley, 1998; Stuijberg et al., 2002). “Some participants mentioned that the most significant impact of fibromyalgia on their marital lives was that the constant pain and fatigue of fibromyalgia had greatly decreased their libido and desire for sexual intimacy” (Arnold et al., 2006, p. 118). On the one hand, spouses have to take on greater responsibilities in the family due to the patients restrictions to participate in the family life. On the other hand they are often denied sexual intimacy due to pain and fatigue. The interplay of these two aspects can create serious strains on the marital relationship.

Kool et al. (2006) investigated the relationship between marital satisfaction and sexual difficulties in 63 women with FMS. Their findings suggest that marital satisfaction weighs more than pain with respect to sexual functioning in this population. The results

also seem to suggest that fatigue may be a more important contributor than pain to the lower sexual activity in the sample.

In summary, fibromyalgia is a syndrome that impacts those afflicted on multiple levels. On the individual level, FMS patients are less able to perform their daily activities because of pain and fatigue. At the same time they are regarded with disbelief and doubt not only by family members, friends, and co-workers, but also by health care providers. They cannot enjoy the same leisure activities they were accustomed to and experience a loss of control of their lives, sometimes being forced to give up education, and careers. On the interpersonal level, FMS patients tend to have smaller social networks than their healthy counterparts or even other chronic pain sufferers. Moreover, they find it difficult to maintain the few relationships they have. As coping strategies, fibromyalgia patients seem to employ avoidant behaviors, contributing to the paucity of their relationships. Marital relations are affected because spouses are forced to take over more than their share of household tasks, and sexual contact is limited.

Alexithymia and fibromyalgia

Alexithymia: general aspects

Definition

The term alexithymia stems from the Greek words: *a* = lack, *lexis* = word, and *thymos* = mood/emotion, referring to a lack of words for feelings (Nemiah, Freyberg, & Sifneos, 1976; Sifneos, 1972). Sifneos (1972) was the first to coin the term that designated a group of affective and cognitive traits characteristic of many patients with psychosomatic disorders. It is important to notice that alexithymia is not a diagnosis *per se* that can be found in any manual of mental disorders. It is rather a set of characteristics

that can exist in people with mental disorders, physical illness, and in the nonclinical population.

Even though the concept of alexithymia has been around for more than three decades, it has recently received more attention with the development of a valid and reliable measurement tool, the Toronto Alexithymia Scale (TAS; Taylor, Bagby, & Parker, 1992). Currently, based on investigations conducted using the TAS, the definition of alexithymia comprises: a) difficulty identifying feelings and distinguishing feelings and physical sensations of emotional arousal; b) difficulty describing feelings to other people; c) reduced imaginative abilities, and d) an externally-oriented cognitive-style (Bagby, Parker, & Taylor, 1994; Bagby & Taylor, 1997; Helmes et al., 2008; Lumley, Beyer, & Radcliffe, 2008; Zackheim, 2007).

Etiology

There are differences in opinions regarding the underlying processes involved in alexithymia etiology. Two major directions emerged from the research addressing the condition: some investigators suggest that alexithymia is a stable personality trait reflecting deficits in cognitive and affective processing (Bagby & Taylor, 1997; Luminet, Rime, Bagby, & Taylor, 2004; Moormann, Bermond, Vorst, Bloemendaal, Teijn, & Rood, 2008). Other researchers hypothesize that the alexithymia features are actually defense mechanisms that are developed as a result of exposure to stressors in the life of alexithymic individuals. Helmes, McNeill, Holden, and Jackson (1998) studied the correlation between defense mechanisms, alexithymia, and social desirability. The findings of the study showed an “association between alexithymia and immature defenses suggesting that early developmental coping styles remain evident throughout adulthood”

(p. 328). Also, the aspects of social desirability that seem to be associated with alexithymia are those that are argued to operate at an unconscious level. These findings suggest that alexithymia may not be an innate individual feature, but rather, an immature coping mechanism learned by exposure to stress that remains operant through adulthood.

Interpersonal aspects

Alexithymia has consequences for the relationships of the people affected by it. The emotional deficits impact relationships, as alexithymics have difficulty understanding and relating to the emotions of others (Espina Eizaguire, 2002; Guttman & Laporte, 2002; Mallinckrodt, King, & Coble, 1998; Spitzer et al., 2005; Vanheule et al., 2007). In the literature on alexithymia's impact on relationships, the following behaviors are reported: cold interpersonal approaches (Vanheule, Desmet, Meganck, & Bogaerts 2007); lower capacity for empathy and a tendency to react with distress to other's negative experiences (Guttman & Laporte, 2002); poor capacity to create meaningful therapeutic relationships with health care providers (Mallinckrodt, King, & Coble, 1998); and almost no expectations from others and no personal initiative to fulfill others' expectations (Vanheule et al., 2007).

In a study on relationship patterns in the alexithymic individuals diagnosed with chronic fatigue syndrome, Vanheule, Desmet, Rosseel, Rhaege, & Meganck (2007) found that for people with alexithymia interactions with others do not have positive results and do not produce good and happy feelings. Using the Core Conflictual Relationship Theme (CCRT) method, the participants in this study were found to "not have faith in others: they do not believe that others are helpful and supporting, or that close interactions could produce feelings of well-being" (p. 96). Thus, they tend to not use relationships in their

coping with chronic fatigue syndrome, depriving themselves of an important source of support.

Spitzer, Siebel-Jurges, Barnow, Grabe, & Freyberger (2005) investigated interpersonal patterns in an inpatient group psychotherapy program with an alexithymic population using the Inventory of Interpersonal Problems. The findings suggest that high-alexithymic patients (TAS-20 scores >61) had significantly more interpersonal problems than low alexithymics (TAS-20 scores <50). From the three subscales of the TAS-20 (Difficulty identifying feelings, Difficulty describing feelings, and Externally-oriented thinking), the Difficulty identifying feelings subscale showed the highest correlation with interpersonal problems. The results in this study indicate that the interpersonal style of alexithymic individuals is characterized by cold and avoidant behavior, and a reduced ability to use relationships for affect regulation.

The couple relationship of people with alexithymia was examined by Espina Eizaguirre (2002) using the Dyadic Adjustment Scale (DAS). The findings in this study suggest that the alexithymic males in the study showed worse marital satisfaction than alexithymic females, showing probably that the difficulties in identifying and expressing emotions contribute to a reduced capacity in negotiating needs in the couple relationship. Multiple regressions showed that for alexithymic males the subscales Difficulty identifying feelings and Difficulty describing feelings were the most correlated with the DAS scores. Interestingly, for females there were no significant differences in the DAS scores between alexithymic and non-alexithymic individuals. Overall, the findings in this study indicate that TAS-20 scores can predict the total dyadic adjustment score and also the Satisfaction subscale score, alexithymia being correlated with a poorer adjustment

score. An important factor seems to be the difficulty in identifying feelings, which impairs negotiation and consensus in the dyadic relationship.

A more recent study on alexithymia and satisfaction in intimate relationships (Humpherys, Wood, & Parker, 2009) that used a path analysis approach, found a moderate negative relationship between alexithymia and satisfaction in relationships, including sexual satisfaction. The researchers found that high levels of alexithymia are correlated to low levels of satisfaction in the relationship.

Posse, Hallstrom, and Backenroth-Ohsako (2002) investigated alexithymia in the general, nonclinical female population using the 20 item- Toronto Alexithymia Scale (TAS-20). They applied the questionnaire to a total of 1023 women and received 864 completed tests. The prevalence of alexithymia in this population was 7.9%. The study showed a significant correlation between global TAS-20 as well as the subscales (Difficulty identifying feelings, Difficulty describing feelings, and Externally-oriented thinking) and lower social support. Actually, having a low level of social support was found to be 3.5 more frequent in the alexithymic part of the population. Furthermore, it was 2.6 times more common for women with alexithymia not to have someone to turn to for support. Alexithymics were found to have less social support than their counterparts even when stressful life events were present. These last two findings may be especially profound for alexithymics with chronic illnesses like fibromyalgia, exposing the vulnerability of this population in time of need.

Alexithymia and health

Since the concept of alexithymia became popularized in the early 70s, the condition has been associated primarily with physical illness. Research on alexithymia

flourished during the past 20 years due mainly to the development and promotion of the TAS and its revised version TAS-20 (Bagby, Parker, & Taylor, 1994; Taylor, Bagby, & Parker, 1992). An electronic search on PsycINFO using as search term *alexithymia* revealed that by the end of 2008 more than 1800 research articles have been published on alexithymia. However, there is not yet a consensus of opinions on the etiology of the condition nor on the mechanisms involved in the association between alexithymia and somatic illness.

In a thorough review of the literature, Lumley, Beyer, and Radcliffe (2008) attempted to answer the question: “Is alexithymia a risk factor for physical health problems?” (p. 44) and what are the pathways through which alexithymia has an impact on the somatic health of individuals affected by it. Synthesizing the literature, they found at least four explanations for the relationship between alexithymia and physical health.

“The first path shows that alexithymia *may cause or exacerbate somatic disease*.

If so, it should do so via one of two possible mechanisms (or subpaths):

alexithymia may induce *physiological changes* that lead to disease, or

alexithymia may contribute to *unhealthy behaviors* that support disease

processes. The second path suggests that alexithymia causes or prompts *illness*

behavior, but not necessarily somatic disease. This pathway also has two

subpaths: alexithymia leads to *somatization* (increased reporting of symptoms),

or alexithymia prompts *health care seeking*, resulting in higher levels of

alexithymia in patients with physical illnesses. The third path indicates that

alexithymia may result from, rather than contribute to, physical illness; that is,

alexithymia is *secondary to illness*. The fourth path is that *some third variable*

leads to both alexithymia and physical illness” (Lumley, Beyer, & Radcliffe, 2008, p. 46).

The first path is the traditional psychosomatic view, that alexithymia causes or exacerbates physical illness, a path that was not found to have important evidence to sustain it by Lumley, Beyer, & Radcliffe (2008). A subpath that may explain the relationship between alexithymia and somatic illness is that alexithymia causes physiologic changes. Two types of physiologic processes have been investigated: immune function and psychophysiological processes. Poor immune function was found to be significantly correlated with alexithymia in multiple studies, two of them highlighting this particular possible pathway (Todarello et al., 1994; Todarello et al., 1997). No sustainable evidence was found for the psychophysiological activity. The authors point out that the studies researched have limitations, one of them being related to the nature of stressors used. They suggest that “interpersonal stress- which we suspect is the most common and important type of stressors in people’s lives- activates the alexithymic person’s affective and physiologic systems in ways that isolated, interpersonally irrelevant stressors do not” (p. 48).

The second subpath proposes that alexithymia may cause somatic disease through unhealthy behaviors. Alexithymia leads to the failure to regulate affect and may prompt people to engage in unhealthy behaviors. The prevalence of alexithymia was found to be higher in individuals with eating disorders, alcohol and other substance abuse or dependence. It was also found in people with gambling tendencies as well as in those with unhealthy life styles. Lumley, Beyer, & Radcliffe (2008) argue that even though

alexithymia may prompt unhealthy behaviors in order to regulate affect, there is no conclusive research to verify this hypothesis and subpath.

The second path proposed was that alexithymia causes illness behavior but not somatic disease; this is to say that, in the fibromyalgia case, for example, alexithymia may be responsible for symptoms of pain and fatigue and functional disability but not necessarily for the pathogenesis of the disease. Alexithymia was found to be significantly correlated with the report of somatic symptoms, but it is not typically related to objective measures of diseases. However, it is still unclear how alexithymia is related to an increased report of somatic symptoms (Lumley, Beyer, & Radcliffe, 2008).

Another subpath of the second path claims that alexithymia causes health care seeking behavior and so it is detected more in the symptomatic population and hence the correlation with somatic illness. The authors argue that even though the difficulty identifying and describing feelings may prompt bodily complaints and increased health care use, the externally oriented thinking may actually divert individuals from bodily awareness and so decrease the use of health care. They suggest that the existing research does not support this subpath and that the future research should be more nuanced regarding the multiple facets of alexithymia.

The hypothesis of the third path is that alexithymia is caused by somatic disease, rather than the other way around. This path seems to support the idea that alexithymia is a learned defense mechanism rather than a personality trait. Numerous studies suggest that alexithymia is increased in people who experienced sexual abuse, and that there is a strong correlation between post-traumatic stress symptoms and alexithymia. Moreover,

patients with kidney failure, cancer, and HIV infection have elevated levels of alexithymia.

Lumley, Beyer, and Radcliffe (2008) argue that all these studies fail to confirm that alexithymia is caused by physical illness; they merely show that alexithymia is significantly correlated with some stressors. They conclude that there are cases in which alexithymia might be developed as a result of exposure to some stressors such as pain and life-threatening illnesses. Such cases highlight the need for more nuanced research in order for a cause-effect relationship to be established.

The fourth pathway states that both alexithymia and physical illness are due to a third variable. Some of the possible third variables mentioned by Lumley, Beyer, and Radcliffe (2008) are genetic vulnerabilities, temperamental features, socio-demographic factors, and neuroticism (e.g., anxiety or depression). By far the variable that has been the most investigated was neuroticism especially because of the frequent presence of symptoms of anxiety and depression in the alexithymic population. These authors found that in the current literature there is no consistent evidence for the “third variable” hypothesis; genetic, temperamental, and socio-economic variables are not sufficiently tested and the neuroticism studies show only a correlation between alexithymia and anxiety and/or depression and not a cause-effect relationship.

In summary, from Lumley, Beyer, and Radcliffe’s (2008) review of the literature it can be implied that alexithymia is related to altered physiology (e.g., poor immune functioning), and that the difficulties in processing emotions prompts unhealthy behaviors such as eating disorders and substance abuse. The authors also concluded that alexithymia is associated with and probably contributes to somatization and a heightened

perception of bodily sensations, especially pain. It also appears that alexithymia can be secondary to some stressors, especially life-threatening or painful conditions such as fibromyalgia.

Alexithymia and fibromyalgia

Clinical levels of alexithymia were reported in the literature to be found in 15% of fibromyalgia patients (Dadabhoy & Claw, 2008; Pedrosa et al., 2008; Rao, Gendreau, & Kranzler, 2007), compared with the general population where alexithymia can be found in approximately 8-9% of males and 5% of females in a non-clinical population (Kokkonen et al., 2001; Posse, Hallstrom, & Backenroth-Ohsako, 2002). It is not clear, however, if alexithymia is a pre-existent condition or is a response to symptoms of the condition such as pain or fatigue. As described previously, in the case of fibromyalgia, alexithymia can either contribute to an intensified perception of pain or it can be secondary to the continuous and sometimes severe pain characteristics of the syndrome, or both (Lumley, Beyer, & Radcliffe, 2008).

Reviewing the research literature, I was able to find three studies that connected FMS and alexithymia. One investigated the relationship between alexithymia and emotional avoidance in individuals with FMS (van Middendorp et al., 2008). The second study investigated the relationship between parenting styles in the family-of-origin and alexithymia in the fibromyalgia population (Pedrosa Gil et al., 2008). The third study looked at the attribution of emotional arousal to somatic causes (Brosschot & Aarsse, 2001) in the same population.

In the first study, van Middendorp et al. compared 403 women diagnosed with FMS with 196 women in a non-clinical group. The researchers investigated emotion

regulations and symptoms of fibromyalgia using self-report questionnaires. The findings showed a large deviation from normal for the TAS scale “Difficulty identifying feelings” and it also showed that after controlling for other variables, only this score seems to differentiate FMS patients from the control group. The researchers excluded the scale “Externally-oriented thinking” keeping only emotion-focused scales. Participants with fibromyalgia in this study were also found to make more use of emotionally avoidant strategies than their non-clinical counterparts. Positive affect was not found to have a buffer effect between pain and negative affect. The study supported the hypothesis that in fibromyalgia patients “affect intensity is related to more severe pain only in combination with the inability to process or verbalize emotions, suggesting that the intense experiencing of emotions is not necessarily maladaptive as long as these emotions are adequately processed” (van Middendorp et al., 2008, p. 165). Thus, the authors suggest that individuals with fibromyalgia may benefit from open discussions and emotion processing not only to improve their relationships but also to improve their FMS-related symptoms. Moreover, interventions that reduce emotional avoidance may lead to a reducing of pain in women with fibromyalgia.

In the second study integrating FMS and alexithymia, Pedrosa Gil et al. investigated 40 women with FMS for alexithymia using the TAS-20 scale and parental bonding style. They found clinically significant alexithymia in 15% of the participants. They also found that father’s indifference was significantly correlated with high scores on the “Difficulty identifying feelings” subscale of the TAS, while mother’s abusive behavior was correlated with high global levels of alexithymia. The findings in this study seem to support the hypothesis that alexithymia is a defense mechanism, a behavior

learned as a result of a problematic parental bonding style. It also seems to suggest that alexithymia in FMS patients is a pre-morbid condition, without necessarily establishing a cause-effect relationship between alexithymia and fibromyalgia.

The third study found that connects FMS with alexithymia was conducted by Brosschot and Aarsse (2001). The hypothesis of this study was that patients with fibromyalgia, due to a restriction in the ability to process emotions, attribute emotional arousal to somatic rather than psychological causes. Affective responses and heart rate were monitored continually for 16 women with fibromyalgia and 17 non-clinical women. FMS patients were found to have a combination of high defensiveness and high anxiousness, to be more alexithymic than the control group and also to have a higher affective-autonomic dissociation, attributing bodily sensation more to somatic than emotional causes. The findings in this study suggest that individuals with fibromyalgia have a restricted ability to process emotions, which is probably related to alexithymia traits of difficulty in identifying and describing feelings. The researchers regard these findings as proof of somatization in FMS. The High defensive/High anxiety trait found in FMS patients suggest that the avoidance strategies used by individuals in this population may be related more to interpersonal anxiety, probably learned in early experiences, than to a repressed relational style.

In summary, the literature to-date shows that alexithymia has a higher prevalence in people with fibromyalgia than in the general population. Similarly with general studies on alexithymia, it is not clear if the fibromyalgia sufferers have alexithymic features prior to the onset of the syndrome, or if alexithymia is developed as a consequence of living with pain. Moreover, in the case that alexithymia is present as a personality trait, it cannot

be implied from the existing research that it can be considered a cause of the fibromyalgia syndrome. It also appears that fibromyalgia patients have difficulties in processing emotions and also that they tend to employ avoidant behavior coping strategies, but it is not clear how the avoidant behaviors are related or not with either the chronic pain or alexithymia.

Couple satisfaction and fibromyalgia

Only a very limited number of studies directly address the quality of the couple relationship among fibromyalgia patients. In fact, using *PsychInfo* search engine only two results were found, both unpublished dissertations, with one of them studying the spouses of fibromyalgia patients rather than the patients themselves. The findings of the one dissertation that focused on family functioning and marital satisfaction in women with fibromyalgia (Chenhall, 1999) suggest that there are no differences in marital satisfaction between the fibromyalgia population studied and the non-clinical (pain-free and chronic illness-free) control group, contradicting a large body of literature on chronic pain couples' relational satisfaction. On the other hand, Bigatti's (2000) doctoral dissertation on spouses of fibromyalgia patients found that the population studied showed lower levels of social support, scored higher on depression, loneliness and subjective stress, and lower on marital satisfaction than control group subjects, being more in accordance with the general literature.

Due to the scarcity of research studies on the quality of the couple relationship in patients with fibromyalgia, I extended my literature search to include marital satisfaction in couples with chronic pain since fibromyalgia meets the criteria for chronic pain. According to the International Association for the Study of Pain (1986), chronic pain is

defined as pain that persists beyond the expected time of healing, 3 months being considered the division between acute and chronic pain, which is consistent with the ACR fibromyalgia definition presented above.

In general, the existing research indicates that couples' scores on marital satisfaction tend to decline after the onset of pain conditions and also that marital satisfaction is associated with pain severity, the presence of physical disability, and depression in patients diagnosed with chronic pain (Cano, Weisberg, & Gallagher, 2000; Cano, Gillis, Heinz, Geisser, & Foran, 2004; Flor, Turk, & Scholz, 1987).

In a comprehensive review of the literature on chronic pain in a couple context, Leonard, Cano, & Johansen (2006) synthesized the existing psychosocial models of pain into four categories: the cognitive-behavioral model, the transactional model, a positive/negative marital functioning model, and the psychological distress model. In the cognitive-behavioral model (Sullivan, Tripp, & Santor, 2000; Sullivan, Thorn, Haythornthwaite, Keefe, Bradley, & Lefebvre, 2001; Turk, Meichenbaum, & Genest, 1983) the evaluation and interpretation of pain is emphasized. Patients and spouses own attitudes and beliefs about pain influence their pain behaviors or the treatment, contributing to behaviors, cognitions, and feelings. In turn their behaviors, cognitions and feelings influence their marital satisfaction. In the case of fibromyalgia, a husband might not fully support his wife's treatment and the change of roles in the household thinking this is not a real problem. The wife, in turn might escalate the expression of pain in order to get the husband's attention and care, both of these attitudes contributing to a low marital satisfaction for both spouses.

Turk and Kerns (1985) proposed a transactional model of health integrating theories such as family systems, cognitive-behavioral models, and coping theories. Basically, this model maintains that couple's appraisals of the situation as well as the available resources determine if a situation is problematic or not. Borrowing from systems theory, in this model emphasis is placed not only on individuals with chronic pain and their spouses but on their relationship and the influence they have on each other.

Burman and Margolin (1992) and Kiecolt-Glaser and Newton (2001) looked specifically at marital functioning and suggested that positive or negative marital interaction might be responsible for health outcomes through variables such as life style, individual differences, and consequent changes in cardiovascular, metabolic, or neurologic systems. In a fourth model of integrating chronic pain, interpersonal tenets, and psychological distress, Banks and Kerns (1996) suggested that people with a psychological diathesis develop depression when they are confronted with stressors, and chronic pain is one such stressor as are stressful relationships. All the models presented identify marital satisfaction, spousal support, and/or marital interaction as being relevant for the experience of chronic pain.

In the same critical review of the literature, Leonard, Cano, and Johansen (2006) looked at pain variables as pain severity, physical disability and activity limitation, pain behaviors, and psychological distress and their relation to marital satisfaction through an important number of empirical studies. Pain severity was not found to be directly related to marital satisfaction in studies by Cano, Weisberg, and Gallagher (2000) or Cano et al. (2004), whereas in others (Flor, Turk & Rudy, 1989; Kerns, Haythornthwaite, Southwick, & Giller, 1990) less pain was associated with lower satisfaction. Many other

studies on chronic pain and couples simply did not report correlations between pain severity and marital satisfaction (see Leonard, Cano, & Johansen, 2006). The reviewers concluded that “there was little evidence for a relationship between pain severity and general marital functioning (i.e, marital satisfaction, positive spousal support). However, marital satisfaction appeared to be an important contextual variable that influenced the relationship between pain-specific marital functioning and pain severity” (p. 381).

Moreover, the relationship between physical disability and marital satisfaction was found inconsistent throughout the studies reviewed. Findings in a couple of studies suggest that disability is positively related to marital satisfaction (Block & Boyer, 1984; Masheb, Brondolo, & Kerns, 2002), while in others the same variables are negatively correlated (Romano, Turner, & Clancy, 1989; Romano, Turner, & Jensen, 1997; Saarijarvi, Rytokoski, & Karppi, 1990). It seems that in the case of physical disability as with pain severity, marital satisfaction can be considered an important contextual variable that affects the degree to which pain and disability are related.

Romano, Turner, & Clancy (1989) and Romano, Turner, & Jensen (1997) suggested that there is a negative correlation between marital satisfaction and pain behaviors. Similarly, Schwartz, Slater, and Birchler (1994) highlighted that chronic pain patients respond more by exhibiting pain behaviors than by active and direct responses in an artificially-created marital conflict situation.

Leonard, Cano, and Johansen (2006) found that the most strong and consistent correlation was shown between marital satisfaction and psychological distress in the chronic pain population. An important number of studies have demonstrated a negative correlation between marital satisfaction and depressive symptoms in this population

Cano, Weisberg, & Gallagher, 2000; Cano et al., 2004; Kerns et al., 1990; Romano, Turner, & Jensen, 1997; Saarjivari, Rytokoski, & Karppi, 1990; Schwartz, Slater, & Birchler, 1996). Moreover, Cano et al. (2004) found that married individuals with chronic back pain that were also diagnosed with depressive disorders reported significantly more marital dissatisfaction than those without depression. The findings of this review strongly suggest that the relationship between chronic pain and marital satisfaction are not modulated by pain severity, physical disability, or pain behaviors, but rather by the psychological distress either caused by pain or prior to the onset of pain.

A more recent study (Johansen & Cano, 2007) investigated the relation between affective marital interaction and depressive symptoms in both patients and spouses and pain severity in the chronic pain patient. The findings suggest that expressing humor was positively related to marital satisfaction in both spouses, whereas sadness and anger were related with greater depressive symptoms and more pain severity in the chronic pain population. Interestingly, when both partners in the couple were chronic pain patients expressing sadness was related to fewer depressive symptoms and less pain severity. This particular finding suggests that partners without a chronic pain condition may fail to empathize with their spouses in pain and thus, preventing effective affective interaction.

Newton-John and de C Williams (2006) used mixed methods (qualitative and quantitative) to investigate patient-spouse interactions in detail in a chronic pain couples population. Their qualitative analysis showed twelve categories describing spousal ways of relating to individuals with chronic pain; provide help, offer help, observe only, discourage pain talk, encourage pain talk, encourage task persistence, shield, express frustration, ignore, problem-solve, hostile-solicitous, and distraction. The quantitative

statistical methods (two-ways ANOVA) showed that marital satisfaction was significantly higher in patients who rated themselves as talking more frequently about their pain. On the other hand, spouses' perceived frequency of pain talk was not related to spouse marital satisfaction. There were no gender differences in marital satisfaction in this study. The findings in this study suggest that patients should be encouraged to discuss pain management with their spouses as this aspect of marital interaction can have a positive effect on the quality of their relationship.

In summary, the studies reviewed in this section suggest that marital satisfaction in couples with chronic pain depends more on psychological well-being or distress and the quality of marital interaction than on variables related to the condition such as pain severity, physical disability, or pain behaviors. In the case of the alexithymic segment of the fibromyalgia population, which is the targeted population for the current study, one may hypothesize that the reported scores for marital satisfaction would be lower than their counterparts with fibromyalgia and without alexithymic features, independent of pain variables.

Attachment theory

General aspects

The present study will be conducted from an adult attachment theory perspective on couple dynamics in which at least one of the partners is diagnosed with fibromyalgia. This theory provides a suitable framework for understanding couple processes in the case of chronic illness and has been used as such (Schmidt, Nachtigall, Wuetrich-Martone, & Strauss, 2002; Stiell, 2007; Williamson, Walters, & Shaffer, 2002). Attachment processes have been studied as linked to different health problems such as unexplained

physical symptoms (Taylor, Mann, White, & Goldberg, 2000), satisfaction with weight and nutrition, level of exercise (Feeney, 1995), ulcerative colitis (Maunder et al., 2000), outcomes in diabetes (Turan, Osar, Turan, Ilkova, & Damci 2003), and likelihood of developing breast cancer in woman (Tacon, 2003). Moreover, attachment-based couple therapy models were found to be effective in working with couples dealing with chronic illnesses (Kowal, Johnson, & Lee, 2003; Stiell, Naaman, & Lee, 2007).

In Bowlby's (1982) original conceptualization, the purpose of the attachment system is to maintain closeness to a primary caretaker in order to ensure safety in situations of perceived. This attachment system will be promptly activated in conditions such as anxiety, fear, and in life-threatening situations. Bowlby noticed that in such conditions infants display so called *attachment behaviors* meant to re-establish proximity with the caregiver, the *attachment figure* and to restore a sense of security. Bowlby argued that the child's confidence in the availability of an attachment figure is essentially determined by the child's early experiences with the primary caregiver. According to Bowlby (1982), proximity maintenance, which includes proximity seeking and separation protest, safe haven, and secure base are the three defining features as well as the main functions of an attachment relationship.

Ainsworth (1978) expanded Bowlby's conceptualization of the secure base as having only the role of protection from predators. For Ainsworth, the attachment system functions continuously to provide a *secure base* from which the infant can engage in exploration of the world. Ainsworth and her colleagues studied individual differences in the infants' security of attachment through the well-known laboratory experiment called

the “Strange Situation” (Ainsworth, Blehar, Waters, & Wall, 1978). The researchers noted that the goal of the attachment system is to maintain a sense of *felt security*.

Based on the infants’ responses to separation and reunion episodes, Ainsworth identified three patterns of interaction displayed by infants toward their parents. The first category is that of the *securely attached* infants. These children welcome their parents return, and when distressed seek proximity and get comforted by it. The second category is that of the *anxious-resistant* infants. These infants are not comforted by the parents return and, generally display ambivalent behavior toward the caregivers. The third category is *avoidant* attachment, where infants do not seem very distressed during the separation from their caregivers, and they avoid proximity when the caregiver returns.

For Bowlby, the importance of attachment it is not limited to childhood. He noted that “childhood attachment underlies the later capacity to make additional bonds, as well as a whole range of adult dysfunctions, including marital problems, and troubles with children as well as neurotic symptoms and personality disorders“ (1977, p. 206) showing the importance of attachment disturbances throughout the developmental stages. Even though Bowlby’s main focus was on describing how infants become emotionally attached to their primary caregivers and emotionally distressed when separated, he also contended that “attachment behavior characterizes human beings from cradle to grave” (1979, p.129). Moreover, he highlighted that the strongest human emotions, either positive or negative, typically arise within meaningful relationships, which he calls attachment relationships (Bowlby, 1982).

Adult attachment

Attachment styles

A comprehensive definition of adult attachment is provided by Montebanocci, Codispoti, Baldaro, and Rossi (2004). The researchers defines adult attachment as “the stable tendency of an individual to make substantial efforts to seek and maintain proximity to and contact with one or a few specific individuals, who provide the subjective potential for physical and psychological safety and security” (Montebanocci et al., 2004, p. 499). The same authors define attachment styles as referring to “particular internal working models of attachment that determine people’s behavioral responses to real or imagined separation and reunion from their attachment figures” (p. 500).

Research on adult attachment as a framework for understanding close relationships started to flourish in the late 1980s. Hazan and Shaver (1987, 1994), Shaver and Hazan (1988), and Shaver, Hazan, and Bradshaw (1988) conceptualized romantic love as an attachment process and also developed the first attachment self-report questionnaire to be applied to adults. In two studies using this self-report tool, they tested the key concepts of attachment theories as developed by Bowlby and Ainsworth on young adults in an attempt to translate the concepts from infants to adult relationships. The translation centered on the three attachment styles found in infancy: secure, avoidant, and anxious-resistant. The findings suggest that the “relative prevalence of the three attachment styles is roughly the same in adulthood as in infancy, the three kinds of adults differ predictably in the way they experience romantic love, and attachment style is related in theoretically meaningful ways to mental models of self and social relationships

and to relationship experiences with parents” (Hazan & Shaver, 1987, p. 511). Their research was ground-breaking and paved the way for the other seminal work in the field.

Hazan and Shaver (1987, 1994), Shaver and Hazan (1988) and Shaver, Hazan, and Bradshaw (1988) consider close adult relationships as involving the integration of three behavioral systems: attachment, caregiving, and the sexual system. In their 1988 article on love as an attachment process, Shaver and Hazan explain how an individual caregiving and sexual behavior is influenced by the attachment style, since the attachment system is the first of the three behavior systems to appear in the course of development. Thus, securely attached individuals are usually comfortable with giving and receiving care, being able to give the kind of care the other person wants and needs, and at the time when it is wanted or needed. Securely attached adults tend to use sexual behavior for mutual intimacy and pleasure. Persons with avoidant attachment styles have supposedly less experience in receiving care, which predicts less willingness to provide care. The same aversion to closeness translates in the sexual behavior of avoidant individuals, who maintain emotional distance and may be promiscuous.

Anxious/ambivalent adults experienced inconsistent caregiving during childhood. As a result, they give care in a compulsive way, not necessarily when the other person needs or wants it. They tend to be dissatisfied with the care they receive. Anxiously/ambivalent adults experience intense sexual desire and try to satisfy their needs for love and intimacy through sexual behavior.

One of the classic articles in the attachment research is Bartholomew’s (1990) work on adult attachment style, a theoretical article which was followed by a research study that tested the four styles described in the initial work (Bartholomew & Horowitz,

1991). In her article on adult avoidance of intimacy, Bartholomew (1990) proposes a four-style model of adult attachment based on internal representations of self and other as presented in figure 3.

The *secure* style in the Hazan and Shaver (1987) study corresponds to Bartholomew's (1990) *secure* model, whereas the *anxious/ambivalent* style becomes the *preoccupied* style in Bartholomew's research. Hazan and Shaver's *avoidant* style has two correspondents in Bartholomew's four-category model: *dismissing* and *fearful*, with the *fearful* model being closer to Hazan and Shaver's conceptualization of avoidance. The main difference between the *dismissing* and *fearful* styles stems from their different models of self: *dismissing* individuals deny the need to be close to others and are self-reliant, whereas *fearful* adults want intimacy but avoid it for fear of rejection (Bartholomew & Horowitz, 1991)

		MODEL OF SELF (ANXIETY)	
		Positive (Low)	Negative (High)
MODEL OF OTHER (AVOIDANCE)	Positive (Low)	SECURE High self-worth, believes that others are responsive, comfortable with autonomy and in forming close relationships with others.	PREOCCUPIED A sense of self-worth that is dependent on gaining the approval and acceptance of others.
	Negative (High)	DISMISSING Overt positive self-view, denies feelings of subjective distress and dismisses the importance of close relationships.	FEARFUL Negative self-view, lack of trust in others, subsequent apprehension about close relationships and high levels of distress.

Figure 3: Styles of adult attachment (Bartholomew, 1990)

Using Bowlby’s and Ainsworth’s observations, Bartholomew investigated the patterns of adult avoidance of intimacy. She states that “adult avoidance of intimacy can be understood as a disturbance in the capacity to form interpersonal attachments which stems from the internalization of early adverse experiences within the family.” (Bartholomew, 1990, p. 149) Satisfying intimate relationships are perceived by Bartholomew as being “the most important source of happiness and sense of meaning in life” for most people. Based on the attachment theories mentioned above and building on models of self and others, this author conceptualized four styles of adult attachment (1999): secure, preoccupied, dismissing, and fearful (see figure 3).

A *secure* attachment style springs from a warm and responsive parenting, which enables the formation of positive aspects of self and other that ensures fulfilling adult

relationships. This style is characterized by low avoidance and low anxiety. A person with a *preoccupied* attachment style has low avoidance and high anxiety. They were children who experienced inconsistent and insensitive parenting and became adults with an “insatiable desire to gain other’s approval and a deep-seated feeling of unworthiness.” (Bartholomew, 1990, p. 163). In adulthood, *preoccupied* adults show strong dependency needs, reaching out to their partners in a compulsive way in order to fulfill these needs. They do not avoid relationships; they are rather enmeshed in interpersonal interaction as a way of decreasing their high anxiety.

Bartholomew’s (1990) study focused on the two newly developed avoidant styles of attachment: *fearful and dismissing*. The *fearful* style is characterized by high anxiety and high avoidance. These individuals learned in their primary relationships that they are unlovable and that others are unavailable and uncaring. As adults, they desire close relationships but they cannot trust their partners; they fall in love very easily, are extremely jealous, they have an obsessive preoccupation with the responsiveness of their partner and assert their own needs without regarding adequately their partner’s feelings and needs. As a result, such individuals avoid social situation and/or intimate relationships in which they may experience rejection, depriving themselves of the very opportunities where they can modify early attachment representations. The *fearful* individuals have difficulties with both autonomy and intimacy as they seem to be caught in a getting close – avoidance conflict.

The last style of attachment, the *dismissing*, is characterized by low anxiety and high avoidance. Practically, individuals with this attachment style have the attachment system deactivated: they avoid close relationships, and value independence and

assertiveness. As opposed to the *fearful* individuals, the *dismissing* adults have a sense of self-worth and they achieved autonomy, based on models of self and others that minimize the importance of close relationships. Their avoidance of intimacy is a defensive mechanism against the anxiety inherent in any close relationships; they either do not engage in intimate relationships or have a tendency to maintain distance in “close” relationships. Even though *dismissing* adults had troubled early attachment experiences, they managed to separate affective reactions from the cognitive images of childhood events and developed an autonomous, independent model of self that does not need to rely on others. When asked about childhood relationships they use idealized descriptions but are unable to provide supporting examples. *Dismissing* individuals are judged to be hostile by their peers and are prone to engage in uncommitted sexual relationships and to use alcohol and other substances in order to reduce anxiety (Hazan & Shaver, 1994).

In social terms, the *dismissing and fearful* groups show avoidance of intimate relationships, and on the other hand, the *preoccupied and fearful* groups show strong dependency needs. Bartholomew (1990) noted that “individuals with a *dismissing* and *fearful* attachment style are expected to choose social environments and partners and to exhibit interactive patterns that confirm their disinterest in or fear of establishing close attachments. The two groups are hypothesized to differ in degrees of social dominance, with the *fearful* avoidant adopting a more passive introverted stance and the *dismissing* a more hostile controlling stance” (p. 173).

Bartholomew and Horowitz (1991) tested the four-style model of adult attachment. Each participant’s degree of correspondence with each style was assessed through a semistructured interview concerning the person’s peer relationships and early

attachments in the family of origin. Multiple regression analysis confirmed the validity of the theoretical four-category model of attachment. Since then, researchers have increasingly adopted the four-group model of adult attachment.

Attachment and couple relationship quality

A significant number of research studies attest to the link between adult attachment style and the quality of the couple relationship. Usually, secure attachment style is linked with high levels of trust, commitment, and satisfaction, while avoidant or anxious styles are reported as negatively related to these variables. These findings are consistent with the basic tenets of attachment theory.

Some studies have found gender-specific differences in the relationship between attachment style and marital satisfaction. For example, Collins and Read (1990) showed that women's relationship anxiety was positively correlated with jealousy and low levels of closeness and marital satisfaction. For men, comfort with closeness seemed to have the most important negative impact on marital satisfaction. As Feeney (2008) noted, "these findings may reflect sex-role stereotypes, whereby women are socialized to value emotional closeness and men are socialized to value self-reliance. Given that relationships are rated negatively when the woman is anxious about relationships and when the man is uncomfortable with intimacy, it seems that extreme conformity with sex-role stereotypes may be detrimental to relationship quality (p. 466).

An important body of research linked attachment aspects to relationship quality (e.g., Banse, 200; Feeney, 2002; Kobak & Hazan, 1991; Meyers & Landsberger, 2002). These studies showed that secure attachment style is positively correlated with higher marital satisfaction, less rejection, and more support during periods of stress. Studies

which address the issue of communication in evaluating the impact of attachment security on relationship quality found similar results. For example, in a study on newlyweds, Feeney, Noller, and Callan (1994) assessed avoidance and anxiety in marital relationship and three dimensions of communication (quality of daily interactions, nonverbal accuracy, and conflict styles). Their findings suggest that husbands' comfort with closeness is linked with their ratings of involvement, self-disclosure, and satisfaction, whereas wives' relationship anxiety was linked with dissatisfaction, and conflict. More recent research (Anders & Tucker, 2000) found that avoidance and anxiety are linked to lower levels of communication competence.

Given the strong relationship between attachment features and marital satisfaction, researchers started to study what the mechanisms are which link these interrelated aspects. Research has shown that insecure individuals use more dysfunctional coping strategies to deal with psychological distress (Lussier, Sabourin, & Turgeon, 1997), whereas secure individuals use more problem-focused strategies, or support-seeking strategies to manage conflict and relationship anxiety (Feeney, 1998; Mikulincer & Florian, 1988). Moreover, securely attached adults use social support as a coping mechanism more often than insecurely attached individuals. Davis, Morris, and Kraus's (1998) findings suggest that insecurely attached adults have lower levels of global support, family support, and support from friends or partners compared to those with a secure attachment style. More recently, Meyers and Landsberger (2002) investigated whether psychological distress and social support mediate or moderate the relationship between attachment style and marital satisfaction. Using a self-report questionnaire with a community-based sample of married women, the researchers findings suggest that

social support functions as a mediator in the relation between avoidant attachment and marital satisfaction, while psychological distress mediates the relation between secure attachment and marital satisfaction. Psychological distress moderates the relationship between both secure and avoidant style and marital satisfaction. The authors highlighted the importance of social support for marital satisfaction: “the overarching social isolation attendant to avoidant attachment is truly associated with marital dissatisfaction rather than with attributes of the attachment style per se. Moreover, avoidant attachment connotes lower levels of assistance and reassurance from friends and all family members rather than solely implying withdrawal from marital relationships” (Meyers & Landsberger, 2002, p. 168).

Feeney (2008) summarized other key aspects of relationship quality associated with attachment dimensions found significant in research studies. Discomfort with closeness (avoidance) was found correlated to relationship dissatisfaction through distrust of partner, low commitment, low interdependence, low level of support, low levels of self-disclosure, low tendency to forgive, and low interpersonal competence. Relationship anxiety and relationship satisfaction were mediated by distrust of partners, jealousy, high levels of conflict, distress and hurt due to conflict, coercive and dominating conflict tactics, maladaptive attributions for negative partner behavior, low tendency to forgive, and interpersonal competence (p. 471).

As mentioned above, Hazan and Shaver (1987, 1994), Shaver and Hazan (1988) and Shaver, Hazan, and Bradshaw (1988) consider intimate adult relationships as involving the integration of three behavioral systems: attachment, caregiving, and the

sexual system. For the purpose of the current study, research on attachment and caregiving are reviewed based on the assumption of the relation between the two factors.

Carnelley, Pietromonaco, and Jaffe (1996) studied the relation between attachment and caregiving, and its implication for marital satisfaction. Secure individuals were found to be able to provide more appropriate and beneficial care to their partners than insecurely attached adults. Furthermore, individuals' own attachment style, partners' attachment style, and partners' provision of care all contributed to marital satisfaction. Supporting this finding, Feeney (1996) found that secure attachment style is linked to beneficial caregiving to the spouse. More specifically, comfort with closeness and low relationship anxiety was related to appropriate and less compulsive caregiving. In the same study, marital satisfaction was found to be higher for securely attached individuals and for those whose partners reported more beneficial caregiving.

Feeney and Collins (2004) have developed an expanded conceptualization of caregiving by distinguishing between the "safe haven" and "secure base" aspects of it. The "safe haven" caregiving refers to responding to the partner's distress when needed, and has been the focus of the caregiving research so far. The second aspect has been researched less often; the "secure base" concept, which involves encouraging and supporting the partners' growth even in situations of stress. These authors developed a model by integrating these processes, which acknowledges the complementary roles of caregiving and care receiving.

Alexithymia and attachment aspects

A significant body of research has focused on the relationship between adult attachment behavior and alexithymia. Overall, these studies show that insecurely attached

individuals are more prone to have alexithymic features than their securely attached counterparts. This finding follows the early development of the attachment theory when theorists suggested that affect regulation and quality of attachment are closely linked (Bowlby, 1979; Bowlby, 1982; Hazan & Shaver, 1987; Shaver and Hazan, 1988).

Troisi et al. (2001) hypothesized that alexithymia as a personality trait is correlated with insecure attachment in young men diagnosed with mood disorders symptoms (depression, anxiety, or mixed features). The findings of this study suggest that alexithymic features are more present in participants with patterns of insecure attachment and who reported more severe symptoms of separation anxiety in childhood, independently of the severity of their affective symptoms. Among the insecure attached participants, those with fearful and preoccupied styles of attachment showed a higher prevalence of alexithymia than those with a dismissing style. These results show that early attachment events may play a role in the etiology of alexithymia and also that the condition tends to be more prevalent in the insecurely attached population. These findings were consistent with those from another study of an Italian team of researchers (Montebarocci et al., 2004). They found moderate correlations between the Difficulty in Identifying and Communicating feelings subscales of the TAS-20 and the ASQ (Attachment Style Questionnaire; Feeney, Noller, & Hanrahan, 1994), and only a low correlation between the Externally Oriented Thinking subscale of TAS-20 with the ASQ subscales.

Another research with findings that support a positive correlation between attachment insecurity and alexithymia features is Picardi, Toni, and Caroppo's (2005) study on the correlation between alexithymia and the 'Big Five' personality traits,

temperament, character, and attachment style. According to Goldberg (1992), the ‘Big Five’ personality traits are openness, conscientiousness, extraversion, agreeableness, and neuroticism. In addition to linking insecure attachment to high levels of alexithymia, this study confirmed that depression, anxiety, and alexithymia are distinct constructs that can be measured independently since neither the Big Five factors nor character or attachment dimensions uniquely explained more than 20% of TAS total variance. The authors concluded that “alexithymia should occupy a distinct place among personality constructs” (Picardi, Toni, & Caroppo, 2005, p. 376).

De Rick and Vanheule (2006) investigated the relationship between alexithymia as a stable personality trait on the one hand, and attachment style and perceived parenting in an alcoholic population in Belgium. The study showed that in this population avoidant attachment was differentiating between high and low alexithymics, so that individuals with high alexithymic scores showed an avoidant style of attachment. Participants in this subgroup – high alexithymia scores, avoidant attachment – seem to have experienced a lack of emotional warmth from the father during childhood. The methodology used in this study – multiple regression analysis – do not allow the investigators to establish a cause-effect relation between the cold emotional parenting received from the father on the one hand, and alexithymia and avoidant attachment on the other hand.

In a complex methodological study, Malinckrodt and Wei, 2005 used structural equation modeling to explain the correlation between attachment anxiety, avoidance as independent variables, and perceived social support and psychological distress as outcomes. Social self-efficacy was hypothesized to be a mediator for attachment anxiety, and alexithymia to be a mediator only for avoidant attachment. The study showed that

both attachment anxiety and avoidance were positively associated with psychological distress and negatively associated with social support. Furthermore, the researchers found that both attachment anxiety and avoidance were positively associated with alexithymia. Persons with high attachment anxiety tend to rate themselves low in their ability to identify and communicate feelings to others suggesting that they do not have a nuanced awareness of their own feelings even though they exhibit intense distress on the activation of the attachment system. Besides the positive correlation between avoidant behavior and alexithymia, for persons with high avoidance the correlation with social self-efficacy proved to be significant. These individuals seem to perceive themselves as relatively unable to form new friendships or to be proactive in improving their social network. Malinckrodt and Wei (2005) conclude that both alexithymia and deficits in social competency explain a “significant portion of the link between adult attachment insecurity and interpersonal problems” (p. 366).

Testing the association between adult attachment style and health outcomes, with alexithymia as mediator, Wearden, Cook, and Vaughan-Jones (2002) reported that insecure attachment was associated with alexithymia independent of its association with negative affectivity. Multiple regression analyses showed that the association between avoidant attachment and symptom reporting and emotional preoccupation with the disease was mediated by alexithymia and negative affectivity. This study suggests that adult attachment style *per se* does not necessarily explain the health outcomes studied, but rather the presence or absence of alexithymic features. In a further development of this study, Wearden, Lambertson, Crook, & Walsh (2004) tested the four category model of attachment in the relation between adult attachment and symptom reporting. The

findings in this study suggest that both fearful and preoccupied attachment as well as high levels of alexithymia are significantly correlated with increased symptom reporting, while the dismissing style is not. Multiple regression analysis showed that the correlation between fearful attachment and symptom reporting was partially mediated by alexithymia, whereas the correlation between preoccupied attachment and symptom reporting was mediated mainly by negative affectivity.

In summary, the studies reviewed in this section seem to suggest that insecure attachment is positively correlated with alexithymia. In another words, individuals who score high on TAS-20 are usually among those found insecurely attached using different scales for measuring attachment. More specifically, findings of at least two studies (Troisi, D'Argenio, Peracchi, & Petti, 2001; Wearden et al., 2004) revealed that between the two styles of avoidant attachment (Bartholomew, 1990; Bartholomew & Horowitz, 1991) *fearful* attachment proved to be strongly correlated with high score of alexithymia, suggesting that individuals with both high relationship anxiety and avoidance have more difficulties in identifying and describing feelings than those with a *dismissing* style of attachment (high avoidance, low anxiety). The *preoccupied* style of attachment, which is characterized by high anxiety and low avoidance, was found to be positively correlated with alexithymia, suggesting that the attachment trait that counts for the relation between attachment style and alexithymia is anxiety. Another finding of this review is related to health outcomes; it appears that both insecure attachment and high alexithymia levels are related to increase of symptom reporting and emotional preoccupation with the disease as a way of coping.

Attachment and chronic pain

I was only able to find two research studies that addressed directly or indirectly fibromyalgia and attachment issues (Hallberg, Lillemor, Carlsson, 1998; Steinberg, 2007). Both of these studies were reviewed earlier in this literature review. The syndrome studied here is essentially a chronic pain syndrome and the literature review will be extended to studies that looked at chronic pain and attachment issues.

Attachment mechanisms are activated under threat and when facing stressors (Bowlby, 1977). Mikulincer and Florian (1998) reviewed studies on populations facing a variety of serious stressors such as war, military training, transition to parenthood, pregnancy, divorce, and chronic pain. Chronic pain is considered to be stressful and thus, to activate the attachment system. The authors referred to a study conducted by their team, which assessed the impact of attachment style on coping and adjustment to chronic low back pain. Findings of this study suggest that attachment style moderated the impact of chronic pain on psychological well-being. Only the avoidant and anxious-ambivalent participants with low back pain showed higher levels of psychological distress than their non-clinical counterparts, whereas secure individuals suffering from chronic pain scored better than their healthy counterparts with insecure attachment styles. Moreover, this study showed that attachment style seems to be relevant in the process of coping with chronic pain: securely attached persons appraised their condition in less threatening terms and considered themselves more able to deal with the pain than their insecurely attached counterparts.

Mikulincer and Florian (1998) concluded that “adult attachment style is a valid predictor of the way in which people cope with stressful events. In the vast majority of

studies, the working models of people, in which significant others are available when needed to bring relief and comfort, are manifested in the tendency to seek support when coping with stressful experiences” (p.161). The authors also describe avoidant individuals as inhibiting emotional display, denying negative affects and memories, and devaluing events that may cause painful feelings (Hazan & Shaver, 1987; Mikulincer, Florian, & Tolmacz, 1990), whereas anxious-ambivalent persons are seen as having high reliance on passive, contemplative, and emotion-focused coping.

Anderson and Hines (1994) proposed that attachment theory provides a sound theoretical framework for the study of what they called “psychogenic pain”, suggesting that some chronic pain is a masked plea for assistance in dealing with past attachment traumas. These authors noted that for those with attachment injuries, chronic pain may be not only a source of considerable distress but it can prevent them from being part of relationships that may have been supportive and comforting. Anderson and Hines highlighted that insecurely attached individuals have a tendency to evoke negative responses in others, consistent with their internal models of others, creating a vicious cycle that is harmful in their recovery.

Mikail, Henderson, and Tasca (1994) and Mikail (2006) also proposed attachment theory as a model for understanding the development and adaptation to chronic pain, emphasizing the increased vulnerability to stress of insecure individuals. Their study suggested that securely attached adults would be less susceptible in developing chronic pain and would cope more effectively with chronic pain once diagnosed. Patients with a dismissing style were predicted to avoid reporting problematic pain until the advanced stages, and to perceive others as unavailable to help. Health care professionals will

perceive them as either effectively coping with their condition or unlikely to be cooperative and thus discharge them from care. Fearful patients were predicted to ask for help only when desperate, being perceived by the health care professionals as helpless and hopeless, and being referred to psychological interventions, which in turn would be perceived as rejection by the patients. Finally, the preoccupied category would most likely seek care and to initially idealize the health care professionals. Due to the characteristic ambivalence of this attachment style, patients would feel rejected and would have the tendency to reject or even sabotage treatment.

Only a few studies have empirically investigated the link between the attachment pattern and chronic pain. All of these studies compared secure with insecure adults with chronic pain of diverse etiologies and locations. Some of the most important findings of these studies suggest that insecurely attached individuals describe their pain as more threatening and themselves as less able to cope (Meredith, Strong, & Feeney, 2005; Mikulincer & Florian, 1998) report greater pain intensity and disability (McWilliams, Cox, & Enns, 2000), more distress related to pain (Pearce, Creed, & Cramond, 2001), more physical symptoms in general (Schmidt, Nachtigall, Wuetrich-Martone, & Strauss 2002; Schmidt, 2005), and more anxiety and depression associated with chronic pain (Meredith, Strong, & Feeney, 2005; Meredith, Strong, & Feeney, 2007).

In their study on attachment and coping with chronic disease, Schmidt et al., (2002) found that anxious-ambivalent individuals show more maladaptive emotion-focused coping strategies such as catastrophizing, while avoidant persons utilize maladaptive diverting and denial strategies. In addition, Meredith, Ownsworth, and Strong (2008) suggested that securely attached individuals with high levels of comfort

with closeness and low relationship anxiety show more support-seeking behavior than their insecure counterparts. Moreover, Meredith, Strong and Feeney (2007) found that comfort with closeness is the main moderator between psychosocial and pain variables in a chronic pain population.

Overall, this review of the literature on attachment aspects in chronic pain population showed that insecurely attached individuals are at greater risk of developing chronic pain, greater risk for poor adjustment and coping with, and poor outcomes in the face of this condition. This population has a tendency to perceive pain as more threatening, to have more negative perceptions about social support and to not seek support, to have more maladaptive coping strategies, and exhibit more psychological distress (depression and anxiety) than its securely attached counterpart.

Evidenced by this literature review, there is still a scarcity of research studies on fibromyalgia and its impact on the quality of the couple relationship. From the qualitative research on the impact of the condition at an interpersonal level, FMS patients tend to have smaller social networks than their healthy counterparts or even when compared with other chronic pain sufferers (i.e., osteoarthritis, rheumatoid arthritis). Moreover, they do not seem to be motivated to work hard on maintaining the relationships they have. As coping strategies, fibromyalgia patients seem to employ avoidant behaviors, contributing to the paucity of their relationships. These characteristic are more likely to influence marital interactions. Furthermore, marital relations seem to be affected through the strains of the spouses being forced to take over some of the specific roles of the ill member as well as the negative impact on the sexual aspects of the relationship.

In addition, for the segment of the fibromyalgia patients with alexithymia features marital quality might be affected by the difficulty they have in describing and identifying feelings, which are characteristics of this condition. From the review of the literature on chronic pain, marital satisfaction, and attachment styles, it can be implied that insecurely attached individuals will have more difficulties adjusting and coping with chronic pain and the changes in the roles it implies, as well as a tendency to report lower scores on marital satisfaction. Fearful attachment style, with both high anxiety and high avoidance, seem to be the attachment style that situates adults at the greatest risk for the situations described. Moreover, alexithymia research shows that fearful adult attachment style seems to be the one style the most present in the alexithymic population. Based on this literature review the present study will investigate the correlations between the fibromyalgia impact, attachment style, and marital satisfaction in the alexithymic segment of the fibromyalgia population using a methodology and measurement tools described in chapter three.

Going back to Emily, from her difficulties in talking to her husband about her emotional experiences both with her pain and limitations imposed by fibromyalgia, and also her avoiding sexual contact, one can surmise that she may have alexithymic features or even an insecure attachment style that may play a role in her marital difficulties. These traits can pose difficulties for the couple in addition to the changes that occur with the progression of the disease. They also can strain the couple relationship even when pain is manageable. All these facts are important and may be vital information for Emily's couple therapist. If she has alexithymic traits and/or a fearful attachment, the course of the therapeutic work will most likely be different than when the clinician has to focus

only on the impact of FMS on the members of the couple and their everyday life. Most likely, Emily's therapist would be even more helpful to her and her husband if s/he would have access to some empirical data about the interplay of all these characteristics (FMS impact, alexithymia, attachment style) on the quality of couple relationship.

Chapter 3: METHODOLOGY

Research design

This study employed a quantitative cross-sectional research design with one independent variable (impact of fibromyalgia), two mediator variables (levels of alexithymia and adult attachment style,) and one dependent variable (couple satisfaction). The main purpose of this study was to investigate how alexithymia and adult attachment style, both singly and in combination, are mediating the relationship between the impact of symptoms of FMS and couple satisfaction for the partner with FMS.

Sample

The sample included males and females diagnosed with FMS. Inclusion criteria require that the participants have a diagnosis of fibromyalgia and are in a long-term romantic relationship. Participation in this study implies access to the internet and fluency in English. Participants were selected using a data base provided by the National Fibromyalgia Association and they constitute a convenience sample. In accordance with the recommendations for the sample size for the method that used, structural equation modeling (Bollen & Lennox, 1991), at least 200 participants must complete the research study (10-20 participants per variable).

Procedure

Potential participants were identified using the above recruitment process. Participants were contacted via the Internet. The study was advertised on the National Fibromyalgia Association (NFA) website (see Appendix A). In order to get permission to post the study, I contacted the web-site administrators. The advertisement was posted on the Research/Clinical Trials page of the aforementioned website. The advertised inclusion criteria were: having a FMS diagnosis and being in a long-term intimate relationship. In the message I explained the purpose of the study and the inclusion criteria. Participation was voluntary and optional, and participants had the option to stop completing the survey anytime. Potential participants were informed about the confidential nature of the study. At the end of the advertising message a link to the actual survey was provided. The questionnaires were sent via Internet through surveymonkey.com. The consent form (see Appendix B) was the first page to appear on the screen. In the consent form I explained the purpose of the study, explaining its confidentiality and anonymity. One follow-up message was sent via email to remind possible participants of the opportunity to participate in the research study.

Surveymonkey.com is a website design to administer, collect and analyze surveys. It offers the option of having data collection not be connected with a particular participant so that anonymity is insured. The option I used by posting the link of my survey on the NFA webpage is the Web Link collector. This method does not track anything and as the responses come into the Analyze section of the website, there are no names or emails associated with them. The only email addresses I had access to, were the addresses provided by the participants to be introduced in a raffle. Upon completion of

the survey, participants willing to enter a raffle for three \$50 gift cards for a massage session were asked to provide their email addresses. The internet network is not 100% secure. To make sure anonymity and confidentiality are insured, I asked the surveymonkey.com administrators about their security measures. It was explained to me that the administrators at surveymonkey.com employ multiple layers of security to make sure that the account and the data remains private and secure. They employ a third-party firm to conduct daily audits of the security, and the data resides behind the latest in firewall and intrusion prevention technology, to insure that the data is collected in an encrypted environment.

In the consent form, I explained that as a result of completing the study some emotional distress may occur related to the subject. If any such discomforts arose I offered to identify local agencies that provide psychotherapeutic services. No such incident was reported to me. Due to the Internet administration of this study, a signature was not required. By clicking on the 'Start Survey' option, participants showed that they agreed to participate, they read and understood the description of the study, and that they were 18 or older.

The survey began with the demographic data. Participants indicated their age, gender, race/ethnicity, religion, sexual orientation, education, relationship status, years since symptoms started and diagnosis, income level, job status, and treatment (see Appendix G). The first questionnaire to be completed was *Fibromyalgia Impact Questionnaire* (Bennett, 2005; Burckhardt, Clark, & Bennett, 1991). The second questionnaire was the *20-item Toronto Alexithymia Scale* (Bagby, Parker, & Taylor, 1994) followed by the *Relationship Scale Questionnaire* (Bartholomew & Horowitz,

1991). The last questionnaire to be administered was the *Revised Dyadic Adjustment Scale* (Busby, Christensen, Crane, & Larson, 1995). All four questionnaires are described in more detail below.

Measures

Four scales were included in the questionnaire that the participants completed via the Internet: *Fibromyalgia Impact Questionnaire* (Bennett, 2005; Burckhardt, Clark, & Bennett, 1991), *20-item Toronto Alexithymia Scale* (Bagby, Parker, & Taylor, 1994) *Relationship Scale Questionnaire* (Bartholomew & Horowitz, 1991), and the *Revised Dyadic Adjustment Scale* (Busby, Christensen, Crane, & Larson, 1995).

The *Fibromyalgia Impact Questionnaire* (FIQ; see Appendix C) was originally developed by Burckhardt, Clark, and Bennett (1991) and is used extensively in studies of the impact of fibromyalgia. As a result of experience in using the questionnaire, the original version of this instrument was revised in 1997 and 2002 and the scoring system was modified. Throughout studies, the internal consistency coefficients varied between 0.62 and 0.95, while the test-retest reliability varied between 0.46 – 0.81 and 0.78 – 0.96 (Bennett, 2005).

The FIQ is scored from 0 to 100 with the larger numbers indicating more severe symptomatology. The average score for fibromyalgia patients in rheumatology offices is 50, and severely affected patients are usually at 70 or more (Bennett, 2005).

The FIQ consists of 10 items. The first item contains 11 questions related to physical functioning – each question is rated on a 4 point Likert-type scale. Items 2 and 3 ask the patient to mark the number of days they felt well and the number of days they were unable to work (including housework) because of fibromyalgia symptoms. Items 4

through 10 are horizontal lines on which the patient rates symptoms such as anxiety, depression, pain, stiffness, work difficulty, and fatigue. Each of the 10 items has a maximum possible score of 10.

The *20-item Toronto Alexithymia Scale* (TAS-20; see Appendix D) is a twenty-item self-report survey composed of three subscales: Difficulty Identifying Feelings, Difficulty Describing Feelings, and Externally Oriented Thinking. It was developed by Bagby, Parker, and Taylor (1994) to measure alexithymia. Both exploratory and confirmatory factor analyses have supported the construct validity of the three subscales (Taylor, Bagby, & Parker, 1997). Previous studies (Taylor, Bagby, & Parker, 1997; Parker, Taylor, & Bagby, 2003) showed that the TAS-20 has good internal consistency (Cronbach's $\alpha = 0.81$) and a test-retest reliability over a 3-week period ($r = 0.77$)

Items in the TAS-20 are rated on a 5-point likert-type scale ranging from 1 (strongly disagree) to 5 (strongly agree). Sample items include the following: "I have feelings that I can't quite identify" (Difficulty Identifying Feelings), "It is difficult for me to find the right words for my feelings" (Difficulty Describing Feelings), and "I prefer talking to people about their daily activities rather than their feelings" (Externally Oriented Thinking). The TAS-20 is the most widely used and validated alexithymia self-report measure (Bagby, Parker, & Taylor, 1994; Bagby, Taylor, & Parker, 1994; Parker, Taylor, & Bagby, 2003). A score of 61 or higher on the total scale is a conventional cutoff for classifying individuals as alexithymic; a score of 51 or less is a recommended cutoff for a nonalexithymic classification (Taylor, Bagby, & Parker, 1997).

The *Relationship Scale Questionnaire* (RSQ; see Appendix D) measures adult attachment style according to a four-category model developed by Bartholomew (1990).

It is a 30 item self-report measure of adult attachment styles in intimate adult relationships. The sub-scales are: Secure (5 items), Fearful (4 items), Preoccupied (4 items), and Dismissing (5 items). Griffin and Bartholomew (1994) reported that in previous research the α s for the Preoccupied, Fearful, and Dismissing scales were not lower than 0.65, whereas the Secure subscale was found at the lowest reliability, with coefficients ranging from 0.58 to 0.65 due to the small number of the items per scale. Fraley, Waller, and Brennan (2000) found that test-retest reliabilities for the four subscales ranged from 0.58 to 0.78. Participants rate the items of the RSQ using a 5-point likert-type scale (1- not at all like me, 5- very much like me). Sample items include the following: “I find it easy to get emotionally close to others” (Secure), “I find it difficult to depend on other people” (Fearful), “It is very important to me to feel independent” (Dismissing), and “I find that others are reluctant to get as close as I would like” (Preoccupied).

The *Revised Dyadic Adjustment Scale* (RDAS; see Appendix F) is a 14-item self-report questionnaire. Busby, Christensen, Crane, and Larson (1995) revised the Dyadic Adjustment Scale (Spanier, 1976) because two of its subscales (Dyadic Satisfaction and Affectional Expression) were found problematic. It is also shorter than the original version, which consisted of 32 items, and shows an internal consistency of 0.80 or above on the subscales and the total scale (Busby et al., 1995). The RDAS has three subscales: Dyadic Consensus (6 items), Dyadic Satisfaction (4 items), and Dyadic Cohesion (4 items). Sample items include, “Making major decisions” and “Sex relations” for the Dyadic Consensus subscale, “How often do you and your partner quarrel?” for the Dyadic Satisfaction subscale, and “Work together on a project” for the Dyadic Cohesion

subscale. The items are scored on a Likert-type scale with scores ranging from 0 to 70. The cutoff between distressed and non-distressed couples is considered to be 48, with distressed couples scoring 48 or below (Crane, Middleton, & Bean, 2000).

Analysis

The purpose of the present study was to test the proposition that alexithymia and adult attachment style would explain, partially or totally, the impact of the symptoms of fibromyalgia on the quality of the participants' romantic relationships.

Hypotheses

Hypothesis 1 (partially mediated model): I hypothesized that distress in a couple relationship where at least one of the partners is suffering from fibromyalgia symptoms, is at least partially due to the presence of alexithymic features in the FMS partner. In statistical terms, I hypothesized that the impact of fibromyalgia would influence couple satisfaction for the partner with FMS, both directly and indirectly, through the presence of alexithymia (see Fig.4). Thus, the paths from fibromyalgia impact to alexithymia (path a), and to marital satisfaction (path c), as well as the path from alexithymia to marital satisfaction (path b) were hypothesized to be statistically significant.

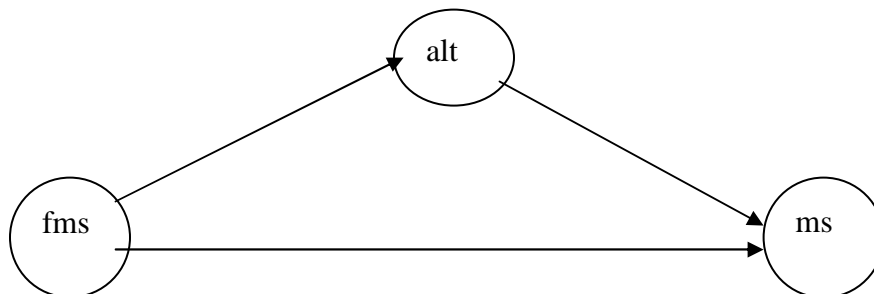

Fig. 4. Hypothesis 1 (path a: fms-alt; path b: alt-ms; path c: fms-ms)

Hypothesis 2 (partially mediated model): I hypothesized that the relationship between fibromyalgia impact and couple satisfaction for the partner with FMS is mediated by adult attachment style. Moreover, based on the literature reviewed, I hypothesized that an avoidant attachment style would be the strongest mediator between the two variables. In another words, I hypothesize that the impact of fibromyalgia will influence couple satisfaction for the partner with FMS, through adult attachment style (see Fig.5). Thus, the paths from fibromyalgia impact to adult attachment style (path d), and to couple satisfaction (path c), as well as the path from adult attachment style to couple satisfaction (path e) were hypothesized to be statistically significant.

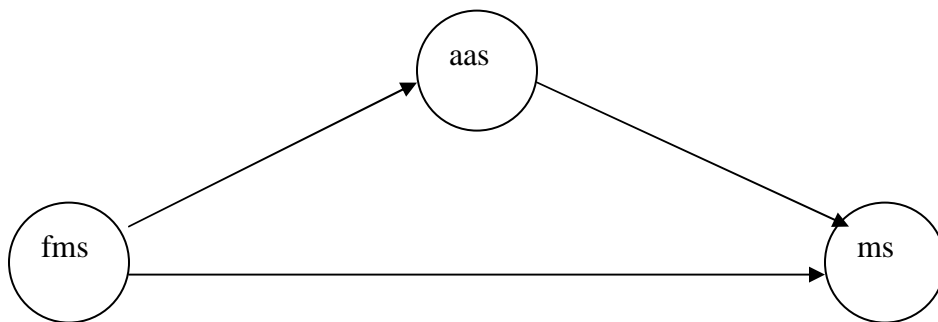

Fig. 5. Hypothesis 2 (path d: fms-aas; path e: aas-ms; path c: fms-ms)

Hypothesis 3 (partially mediated model): Another hypothesis I tested through this study was that the relationship between fibromyalgia impact and couple satisfaction for the partner with FMS is mediated by a combination of alexithymia and adult attachment style.

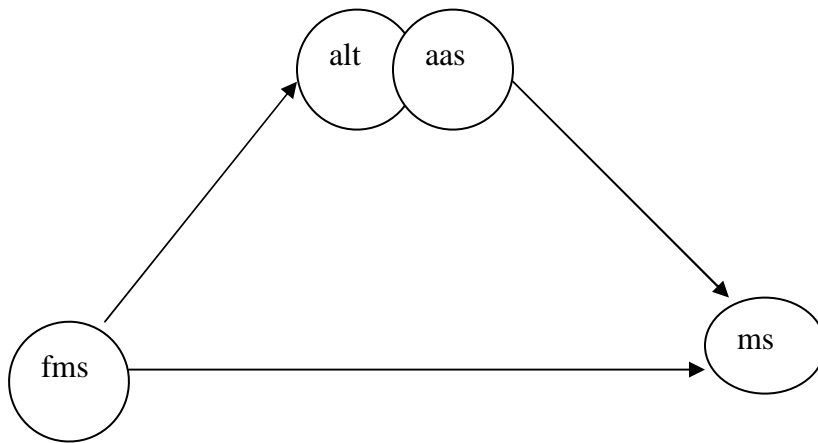

Fig. 6. Hypothesis 3 (path f: fms-alt+aas; path g: alt+ aas- ms; path c: fms-ms)

Hypothesis 4(fully mediated model): The alternate hypothesis proposed was that fibromyalgia symptoms influence the couple relationship for the partner with FMS *only* through the mediation of alexithymia and/or adult attachment style. In statistical terms, I hypothesized that the paths from fibromyalgia impact and alexithymia (path a), between alexithymia and couple satisfaction (path b), between fibromyalgia and adult attachment style (path d), and the path between adult attachment style and couple satisfaction (path e) would be significantly different from zero, while the direct path between fibromyalgia impact and couple satisfaction would not be statistically significant.

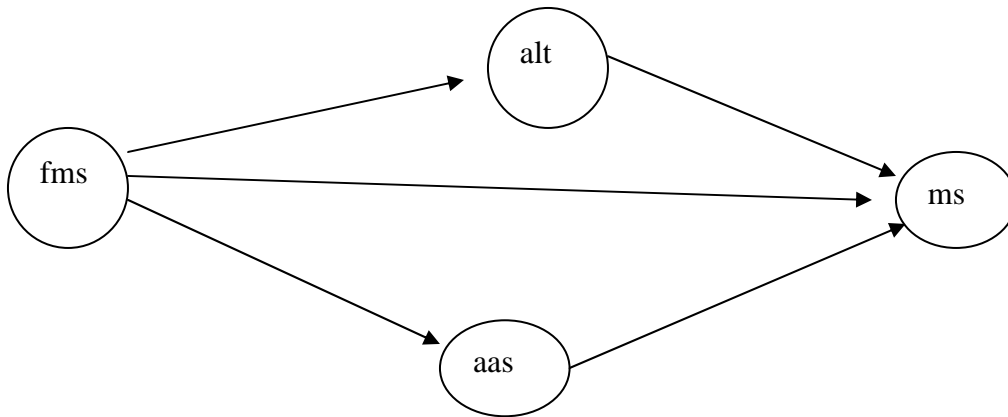

Fig. 7. Hypothesis 4: the overall model (path a: fms—alt; path b: alt—ms; path c: fms—ms; path d: fms—as; path e: as—ms; fms – fibromyalgia impact; ms – marital satisfaction; alt – alexithymia; as – adult attachment style)

The statistical method that is employed to test these hypotheses is the structural equation modeling (SEM). This method was used because it allows the analysis of complex relationships between variables, so that theoretical models can be confirmed or discarded. As Baron and Kenny (1986) highlighted, this method has several advantages over the traditional correlation methods: “all the relevant paths are directly tested and none are omitted as in ANOVA; complications of measurement error, correlated measurement error, and even feedback are incorporated directly into the model” (p. 1177). Moreover, Byrne (2001) highlighted two advantageous aspects of using SEM: “(1) the casual processes under study are represented by a series of structural (i.e., regression) equations, and (2) these structural relations can be modeled pictorially to enable conceptualization of the theory under study” (p. 3). I used the SPSS software to analyze the data obtained and to generate the SE model. Each hypothesis can be tested simultaneously for all the variables to analyze the model. Arbuckle and Wothke (1999)

recommended a critical ratio of 1.96 ($p < 0.05$) and higher to show a significant relationship between two variables.

As recommended by Anderson and Gerbing (1988), the first step in this model is to use confirmatory factor analysis to develop a measurement model with an acceptable fit to the data. An adequate goodness of fit supports the hypothesized model, whereas an inadequate fit rejects the hypothesized relationship between variables. The model fit was tested using indices as goodness of fit (GFI), adjusted goodness of fit (AGFI), comparative index fit (CFI), the root mean square error of approximation (RMSEA), and chi-squares. Byrne (2001), and Kenny, Kashy, and Cook (2005) consider that for a perfect model fit, GFI, AGFI, and CFI should be 1.00, with values above 0.90 acceptable as indicative for a good model fit. For RMSEA, a value of 0 indicates a perfect model fit, while values of less than 0.05 are considered indicative of an adequate model fit. Non-significant chi-squares show that the hypothesized model and the perfect fit are not different. After an acceptable measurement model is developed, the structural equation model can be tested.

Chapter 4: RESULTS

Sample

A total of 208 individuals participated in this study. Of this total sample, 186 identified as White (89.4%), followed by Latino/Latina (4.3%), and Native American and Black/African-American (each 3%). One hundred and ninety eight (95.2%) of the participants are females and 10 participants are males. Twenty-nine percent of the participants were between 46 and 55 years of age, 27% were between 25 and 35, and another 27% were between 36 and 45 years of age.

The majority of the participants identified as heterosexual (91.7%), followed by bisexual (7.2%), and homosexual (1%). Fifty nine percent of the participants identified as religious and another 19% identified themselves as non-religious. From the participants who identified themselves as religious, 85.3% specified various Christian religious affiliation (Christian Orthodox, Roman Catholic, Presbyterian, Protestant, Methodist, Lutheran, Assembly of God, LDS, Church of Christ etc), followed by Buddhist (3.2%) and Pagan (3.2%).

Thirty nine percent of this sample had some college education and 33.2% held a college degree. Another 15% of the participants had graduate level degrees, and 12% had a high-school education. Sixty nine participants in this study (33.2%) worked full-time, another 25.5% were unemployed at the time of the study, followed by 9.1% who worked part-time and 4.3% that were retired. One participant reported being in active military duty at the time of the study. Twenty-two percent of the participants had household income between \$40,000-59,000/year, followed by 17.8% with a household income of 20,000-39,000/year. Those with an income of >20,000/year and 60,000-79,000/year

shared a percentage of 15.4%, while participants with an income of over \$100,000 were at a percentage of 14.9%, and those with an income/year of 80,000-99,000 at 13%.

Relationship statistics showed that 68.3% of the participants were married, 14.8% were living with their partners, while 14.4% described their relationship status as 'in an intimate relationship'. The average amount of time participants indicated being in their current relationship was 12 years (SD=11 years, range: 1-54 years).

Statistics referring to Fibromyalgia indicated that the participants, suffered from symptoms of this syndrome an average of 11 years (SD=8.3 years), and were diagnosed an average of 6 years (minimum time since diagnosis was 1 month). Participants used a variety of treatment options. The most used treatment in this sample was pain medication (70.7%), followed by antidepressants (66.3%), exercise (52%), muscle relaxants (49.5%), massage (33.6%), physical therapy (30%), chiropractic services (27.4%), psychotherapy (20%), and alternative treatments (15.3%). Only 7% of the sample indicated that they were not using any treatment at the time of the study.

Fibromyalgia Impact Questionnaire (FIQ) descriptive statistics

The FIQ is scored from 0 to 100 with the larger numbers indicating more severe symptomatology. The average score for patients diagnosed with fibromyalgia in the literature is 50, and severely affected patients are usually at 70 or more (Bennett, 2005). In this study, scores ranged from 16.06 to 95.28, and 89 participants (43%) scored 70 or more, thus qualifying for the severely afflicted category. Only 10 participants (4.8%) scored less than 50 on the FIQ, the remaining 52% (109 participants) scored between 50 and 70, thus moderately afflicted by their fibromyalgia symptoms.

20-item Toronto Alexithymia Scale (TAS) descriptive statistics

For this questionnaire, a score of 61 or higher on the total scale is a conventional cutoff for classifying individuals as alexithymic; a score of 51 or less is a recommended cutoff for a nonalexithymic classification (Taylor, Bagby, & Parker, 1997). The participants' scores ranged from 29 to 87, with 52% of them (109) scoring 61 or higher (alexithymic) and 48 participants (23%) scoring 51 or less (non-alexithymic).

Relationship Scale Questionnaire (RSQ) descriptive statistics

The Relationship Scale Questionnaire (Bartholomew & Horowitz, 1991) was not originally designed to be a categorical measure of attachment, but as a continuous rating of each of the four attachment patterns (secure, preoccupied, dismissive, and fearful). Therefore no official cutoff has been designated for the various subscales of the measure. However, in order to standardize results, research studies have used mean calculations to standardize scores according to the methodology proposed by the authors of this scale (Bartholomew, 2011). This study used a similar approach by identifying the mean scores of each of the subscales in order to identify the strongest attachment pattern among each participant. Fifty-four percent of the participants were identified as having secure traits of attachment. The most prevalent attachment style in this sample proved to be the dismissing attachment style (75%), followed by fearful attachment (38%) and preoccupied style (33%). These findings suggest that the participants in this study scored more toward the avoidance end of the attachment continuum (anxiety-avoidance).

Revised Dyadic Adjustment Scale (RDAS) descriptive statistics

The RDAS items are scored on a Likert-type scale with scores ranging from 0 to 70. The cutoff between distressed and non-distressed couples is considered to be 48, with

distressed couples scoring 48 or below (Crane, Middleton, & Bean, 2000). The scores of the participants in this study ranged from 8 to 69. Forty percent of the sample (84 participants) scored 48 or below in the category of distressed couples, and the rest of the participants qualified as non-distressed on the RDAS scale.

Bivariate correlations were used as an initial test to address potential multiple collinearity issues between the RDAS and RSQ scales. While some correlations were found between RDAS and different attachment styles (for i.e., dismissing attachment style/RDAS = - 0.178, $p < 0.05$; fearful attachment style/RDAS = -0.362, $p < 0.01$), these correlations are considered low in the literature. Researchers (Grewal, 2004) suggest that multiple collinearity becomes an issue when correlations reach 0.6 - 0.8. Because in this case the intercorrelations between RDAS and different attachment styles are < 0.6 , potential multiple colinearity was ruled out as an issue of concern.

Structural Equation Modeling

The statistical method that was employed to test these hypotheses is the structural equation modeling (SEM). This method was used because it allows the analysis of complex relationships between variables, so that theoretical models can be confirmed or discarded. As Baron and Kenny (1986) highlighted, this method has several advantages over the traditional correlation methods: “all the relevant paths are directly tested and none are omitted as in ANOVA; complications of measurement error, correlated measurement error, and even feedback are incorporated directly into the model” (p. 1177). The SPSS software (SPSS 19, 2010) was used to analyze the data obtained and to generate the SE models.

To date, SEM is one of the most widely used statistical techniques in the social science field. SEM is a confirmatory statistical analysis, a hypothesis-testing approach methodology. Each hypothesized model in the present study was tested statistically to determine the extent to which it is consistent with the data (Byrne, 2001). I used a variety of statistical indices that were obtained using SPSS software for all variables in the models. In SEM, if there is an adequate goodness of fit then the model supports the theoretical hypothesis proposed. On the other hand, if the fit is inadequate then the hypothesized relationship between variables is rejected. Researchers proposed three different models of analysis within SEM (Joreskog, 1998): strictly confirmatory analysis, alternative models and model-generating applications. In the strictly confirmatory analysis, the one model hypothesized is accepted or rejected based on the fit of the data (Kline, 2005). The alternative model refers to situations where more than one models are tested. The last situation, the model-generating application is used when the initial model does not fit the data and is altered or 'trimmed' by the researcher (Kline, 2005). For the purpose of this study, I used the alternative model to test the fit to the data collected because I was testing more than one hypotheses (4 models).

The model of fit was tested using indices as goodness of fit (GFI), adjusted goodness of fit (AGFI), comparative index fit (CFI), the root mean square error of approximation (RMSEA), and chi-squares. Byrne (2001), and Kenny, Kashy, and Cook (2005) consider that for a perfect model fit, GFI, AGFI, and CFI should be 1.00, with values above 0.90 acceptable as indicative of a good model fit. For RMSEA, a value of 0 indicates a perfect model fit, while values of less than 0.05 are considered indicative of an adequate model fit and values as high as 0.08 are reported to indicate adequate model

fit (Byrne, 2001). Non-significant chi-squares show that the hypothesized model and the perfect fit are not different. After an acceptable measurement model was developed, the structural equation model was tested.

Before testing the four hypothesis described above, Pearson correlations were conducted to study the potential impact of the control variables in the models. All of the remaining variables (demographic data, relationship status, length of relationship, duration of symptoms, time from diagnosis, type of treatment) were tested and the correlations were found to be statistically non-significant. This finding suggests that the relationship between the variables tested in this study (fibromyalgia impact, alexithymia, attachment style and couple satisfaction) were not influenced by the control variables and that most probably the relationship found between them is due to their own interactions, strengthening the initial hypothesis.

Hypothesis 1 (partially mediated model).

Hypothesis 1 stated that distress in a couple relationship where at least one of the partners is suffering from fibromyalgia symptoms, is at least partially due to the presence of alexithymic features in the FMS partner. In statistical terms, I hypothesized that the impact of fibromyalgia would influence couple satisfaction for the partner with FMS, both directly and indirectly, through the presence of alexithymia. Findings indicated that the initial model demonstrated a weak fit to the data (GFI= 0.820, AGFI = 0.723, $\chi^2_{(11)} = 267$ ($p < 0.001$), CFI =0.6, RMSEA = 0.16 (Figure 8). In this first model the alexithymia variable was described by its three subscales: Difficulty Identifying Feelings ($b = .94$, $p < .05$), Difficulty Describing Feelings ($b = .74$, $p < .05$), and Externally Oriented Thinking ($b = .0$, $p < .05$). In this particular study, the subscale that seems to not have a direct

contribution to describing alexithymia is EOT (Externally Oriented Thinking), while the subscales addressing managing feelings proved to be significant. These aspects were taken into consideration in testing the following hypothesis as it will be discussed later. However, the overall model was not verified, showing a weak fit to the data and it was discarded (path FM-AL: $b = 0.41, p < .05$; path AL-MS, $b = -0.38, p < .05$).

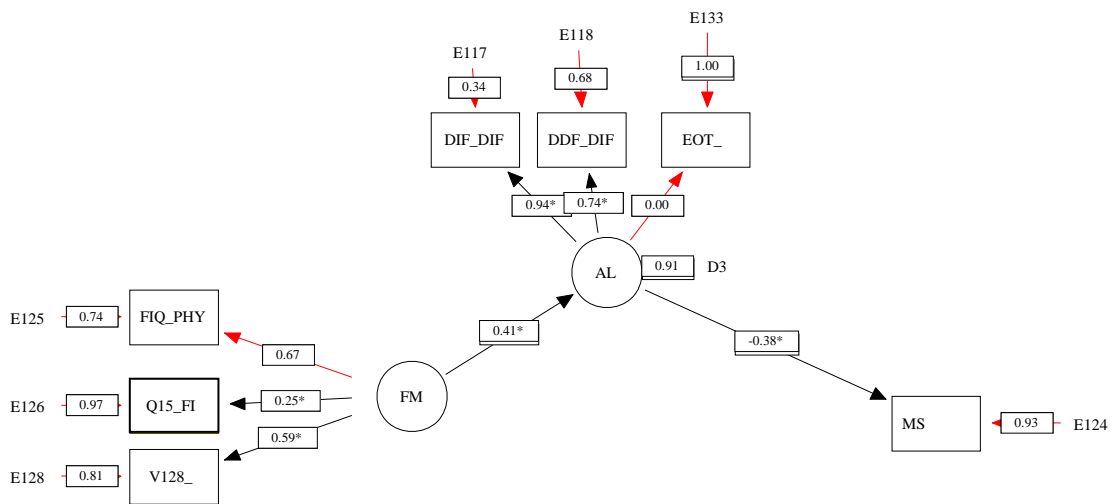

EQS 6 direct alex Chi Sq.=267.00 P=0.00 CFI=0.60

Figure 8: Model 1: partially mediated by alexithymia

Hypothesis 2 (partially mediated model).

In hypothesis 2, I suggested that the relationship between fibromyalgia impact and couple satisfaction for the partner with FMS would be mediated by adult attachment style. In another words, I hypothesized that the impact of fibromyalgia would influence couple satisfaction for the partner with FMS, through adult attachment style. Findings indicated that the initial model demonstrated a weak fit to the data (GFI= 0.811, AGFI = 0.711, $\chi^2_{(11)} = 266$ ($p < 0.001$), CFI =0.6, RMSEA = 0.16) (see Figure 9). In this model, the attachment style variable was a composite of secure ($b = 0.6$, $p < .05$), fearful ($b = 0.9$, $p < .05$), dismissive ($b = 0.5$, $p < .05$), and preoccupied ($b = 0.28$, $p < .05$) types of attachment. In this study, the one attachment style that showed the strongest impact was fearful. The overall hypothesis was not confirmed in this model (path FM-AS, $b = 0.36$, $p < .05$; path AS-MS, $b = -0.46$, $p < .05$).

The testing for hypothesis one and two shows that neither alexithymia alone nor attachment style alone explained the relationship between the impact of fibromyalgia and couple satisfaction. In other words, the fact that a person suffering from fibromyalgia is also alexithymic was not necessarily significant in determining couple satisfaction. Also, the relationship between fibromyalgia's impact and marital satisfaction was not mediated by the individual's attachment style, according to this study.

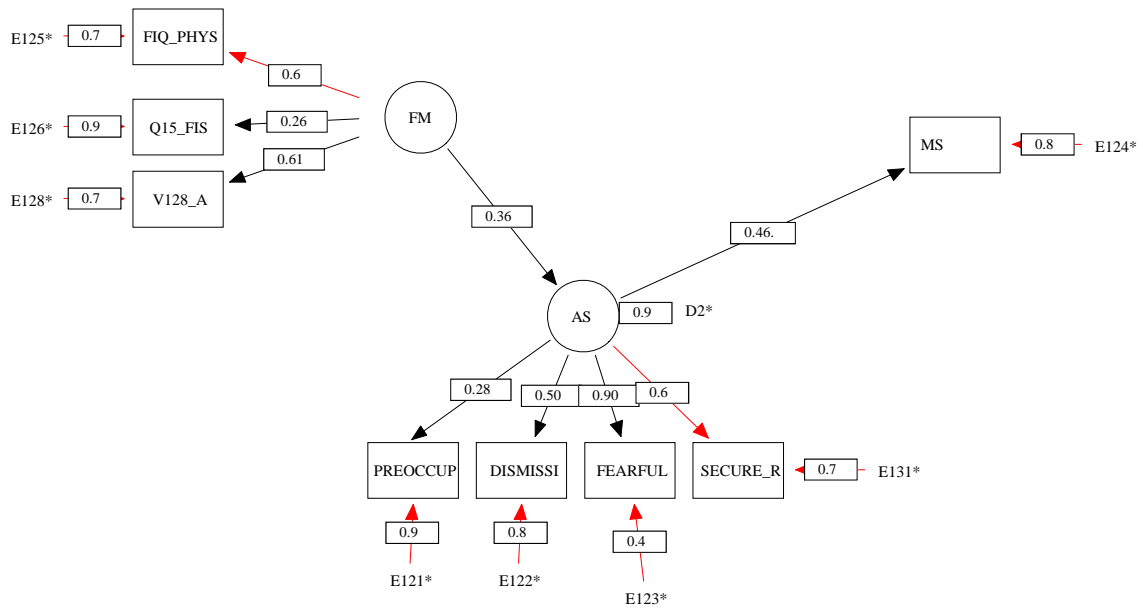

EQS 6 direct attachment Chi Sq.=266.08 P=0.00 CFI=0.60

Figure 9: Model 2, partially mediated by attachment style

Hypothesis 3 (fully mediated model)

In hypothesis 3, I hypothesized that the relationship between fibromyalgia impact and couple satisfaction for the partner with FMS would be mediated by a combination of alexithymia and adult attachment style. The findings for this model proved to be stronger than for the previous two models, but did not show a statistically significant goodness of fit (GFI= 0.887, AGFI = 0.816, $\chi^2_{(11)} = 171$ ($p < 0.001$), CFI =0.77, RMSEA = 0.13) (see Figure 10). As discussed above, EOT (the externally oriented thinking subscale of the alexithymia scale) was tested to determine whether it contributed to the alexithymia variable, and during analysis multiple colinearity was found between EOT and the DIF and DDF variables, suggesting a similar latent construct. Accordingly, the EOT was removed from this model. Likewise in this model, multiple collinearity was found with secure attachment and insecure styles of attachment (preoccupied, fearful, and dismissive), suggesting a similar latent construct. [†] The removal of these two subscales does not change the tested model theoretically. It only had a statistical significance, making the model statistically stronger while the model had the same theoretical significance as it will be discussed in the following chapter.

Hypothesis 3 was then tested without the secure subscale in the attachment style variable and EOT in the alexithymia variable. This new model showed a strong goodness of fit (GFI= 0.963, AGFI = 0.928, $\chi^2_{(11)} = 34.55$ ($p < 0.001$), CFI =0.97, RMSEA = 0.05) (see Figure 10) and confirmed the hypothesis that a combination of the presence of alexithymia and attachment style when individuals had problems processing feelings and were insecurely attached (especially fearful attachment styles) mediated the impact of

[†] These findings may have been due to the fact that individuals who are fearful, preoccupied, or dismissive are less likely to have secure traits. Therefore, the secure attachment was removed from the model to address multiple colinearity issues.

fibromyalgia symptoms on the couple satisfaction for the partners afflicted by this syndrome. In addition, the model showed a correlation between the alexithymia and attachment variables ($b = 0.58, p < 0.05$). In other words, the model showed that for example insecurely attached participants were more alexithymic than securely attached individuals.

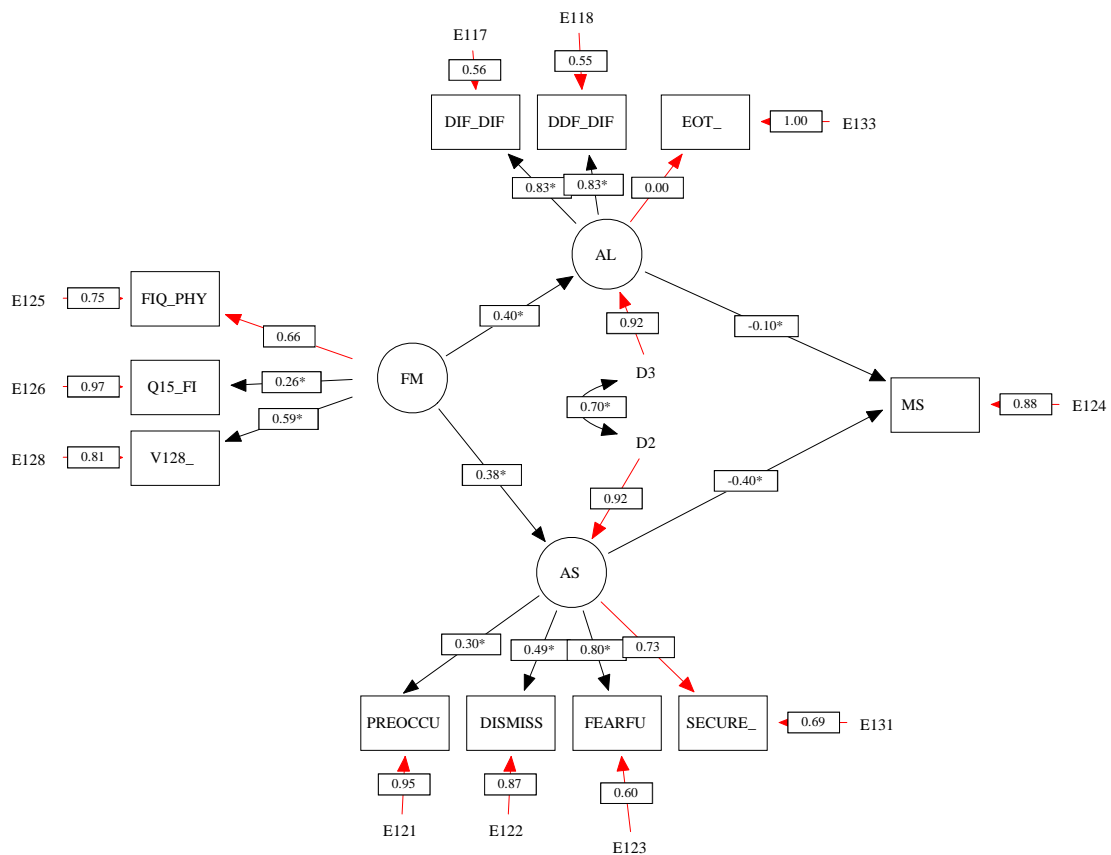

EQS 6 mm 2 mediation with secure and eot Chi Sq.=171.20 P=0.00 CFI=0.77

Figure 10. Model 3, fully mediated model with EOT and secure style included

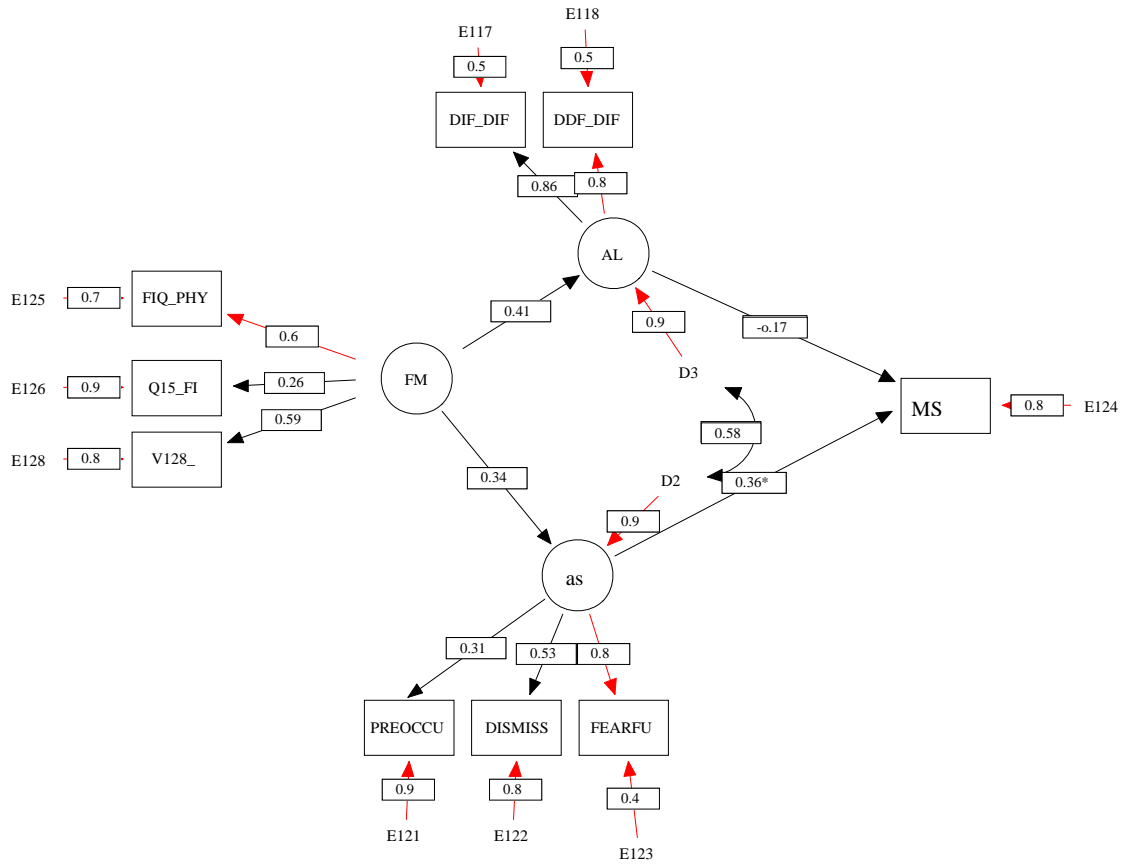

EQS 6 mm cleaned Chi Sq.=34.55 P=0.06 CFI=0.97RMSEA=

Figure 11: Model 4, fully mediated without EOT and secure variable

Hypothesis 4 (fully mediated model).

In order to study the hypothesis that fibromyalgia symptoms influenced the couple relationship for the partner with FMS *only* through the mediation of alexithymia and/or adult attachment style, I tested the direct impact of fibromyalgia symptoms on the couple satisfaction.

The results of testing this hypothesis showed a statistically weak fit to the data (GFI= 0.892, AGFI = 0.805, $\chi^2_{(11)} = 109.14$ ($p < 0.001$), CFI =0.76, RMSEA = 0.13) (see Figure 12). This last model proves that for the sample studied, there is no direct impact of fibromyalgia symptoms on couple satisfaction. Moreover, it shows that the relationship between these two variables is mediated by a combination of the presence of alexithymia and an insecure attachment style, as hypothesized in hypothesis 4.

The model represented in figure 11 that shows how alexithymia and attachment style mediates the relationship between fibromyalgia impact and couple satisfaction provided the best fit for the data, and therefore was used as the foundational model for the discussions that follow.

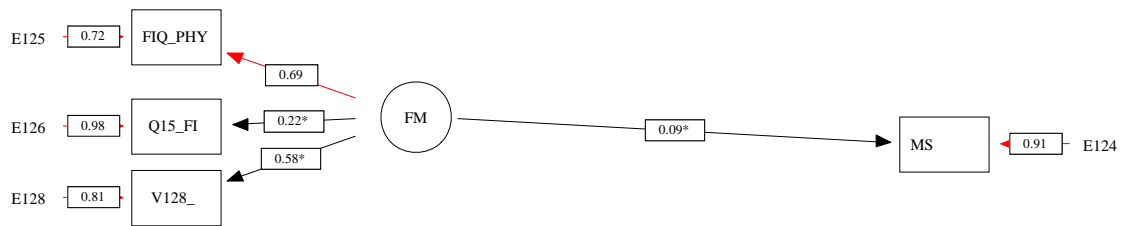

EQS 6 m1 direct paths Chi Sq.=109.14 P=0.00 CFI=0.76

Figure 12. Direct path between Fibromyalgia impact and couple satisfaction

Chapter 5: DISCUSSION

The overall goal of the present study was to examine the impact of fibromyalgia symptoms on the couple satisfaction of individuals afflicted by this syndrome. In particular, this study examined the mediation effect of alexithymic traits and of the attachment style on the relationship between fibromyalgia impact and couple satisfaction. A structural equation modeling statistical analysis was employed in order to assess the relationships between these variables. In this chapter I will discuss possible reasons some of the models I proposed were rejected and reasons why one was accepted as a statistical good fit of the data.

Hypothesis 1

As stated previously, testing hypothesis 1 showed that for this sample alexithymia did not have a mediation role for the relationship between fibromyalgia impact and couple satisfaction in individuals suffering from fibromyalgia. The structural equation modeling analysis did not prove a good fit for the data. In other words, the results showed that having difficulties describing or identifying feelings does not have a significant impact on the perceived satisfaction with relationships for people diagnosed with this syndrome.

Fifty-two percent of the participants scored 61 or higher on the 20 item-Toronto Alexithymia Scale (TAS, 1994), suggesting the presence of alexithymia features. This percentage is higher than the percentages found in previous research which showed only 15% of fibromyalgia patients presenting with alexithymia features (Dadabhoy & Claw, 2008; Pedrosa Gil, Weigl, Wessels, Imich, Baumuller, & Winkelmann, 2008; Rao, Gendreau, & Kranzler, 2007). The present study findings may be explained by the

methodology of the data collection. In the other studies data was collected by a paper and pencil method and in my study I utilized an internet survey. It could be that people find the anonymity of taking the survey on a computer screen more conducive to being more truthful and less concerned with having their data identified by anybody. It could also be that people who spend a lot of time on the computer (those who responded to my requests for research) may have had more problems dealing with their emotions than people who prefer face to face relationships. These are only assumptions and in this technology era we all live in this would constitute an interesting research study. Another assumption is the correlation between high alexithymia scores and high scores on the fibromyalgia impact questionnaire (43% of the sample) even though they were not proven to be statistically significant in this study.

In this study, the two subscales that proved to contribute to the alexithymia construct were Difficulty Identifying Feelings (DIF) and Difficulty Describing Feelings (DDF), while the Externally Oriented Thinking (EOT) did not contribute. This finding is in accordance with previous research on alexithymia characteristics in people with fibromyalgia (van Middendorp et al., 2008; Brosschot and Aarsse, 2001), suggesting that for this population being in touch with their own emotions and describing them, as well as identifying others emotions has more impact than the cognitive processes measured by the EOT subscale. As van Middendorp and her colleagues (2008) suggested when working with these patients an emphasis on processing emotions rather than on cognitive processes might help.

Overall, the mediation relationship in this hypothesis was not supported even after removing the EOT subscale. This finding correlates with previous research in a non-

clinical population (Espina Eizaguirre, 2002). An interesting finding in the Espina Eizaguirre study was that males who scored high in alexithymia reported less marital satisfaction than females with high alexithymia scores. According to the author this finding possibly shows that the difficulties in identifying and expressing emotions for men contribute to a reduced capacity in negotiating needs in the couple relationship, and subsequently leads to low marital satisfaction. Espina Eizaguirre found that for females in his study there were no significant differences in the Dyadic Adjustment Scale scores between alexithimic and non-alexithymic individuals, while for males alexithymia had a significant impact. In my study, the majority of the participants were females, and only 4% were males. The lack of alexithymia mediation in the relationship between fibromyalgia impact and the dyadic adjustment for alexithymic females in my study may be due to this factor. The comparison of my study with Espina Eizaguirre's (2002) study seems to show that there is no difference between non-clinical populations and fibromyalgia populations regarding the relationship between alexithymia and couple satisfaction. This aspect will be addressed later when the direct pathway between fibromyalgia impact and the dyadic adjustment will be discussed.

In summary, the statistical analysis of hypothesis 1 revealed two important aspects:

- a. alexithymia is better described by difficulties in processing emotions than by cognitive processes in the fibromyalgia population studied and
- b. by itself, this difficulty in processing emotions cannot explain poor couple satisfaction for people afflicted by this syndrome.

Hypothesis 2

Findings of the present study showed that the attachment style did not have a mediation role for the relationship between the fibromyalgia impact and couple satisfaction in individuals afflicted by fibromyalgia. The structural equation modeling did not prove a good fit for the data in analyzing this hypothesis. In other words, the results showed that being insecurely attached by itself does not have a significant impact on the perceived satisfaction with relationships for people diagnosed with this syndrome.

As stated in the literature review section, I was not able to find studies that directly addressed the interplay between attachment style and couple satisfaction in this specific population. From the review of the literature on chronic pain, marital satisfaction, and attachment style, it can be implied that insecurely attached individuals will have more difficulties adjusting and coping with chronic pain, a tendency to report lower scores on marital satisfaction as well as more symptoms of anxiety and depression associated with their chronic pain than the general, non-clinic population (Meredith, Strong, & Feeney, 2005; Mikulincer & Florian, 1998; McWilliams, Cox, & Enns, 2000; Pearce, Creed, & Cramond, 2001; Schmidt, Nachtigall, Wuetrich-Martone, & Strauss 2002; Schmidt, 2005). Fearful attachment style, with both high anxiety and high avoidance, seem to be the attachment style that characterizes adults at a greater risk for the situations described above. According to Brosschot and Aarsse (2001), this attachment style is one of the most prevalent in the fibromyalgia population. In another study, van Middendorp and her colleagues (2008) found that avoidance traits are more present than anxiety traits in patients suffering from symptoms of FMS.

In the present study, multiple collinearity issues were found between the secure attachment subscale and the insecure attachment subscales suggesting a similar latent construct. As explained above, this may be due to the fact that individuals who are fearful, preoccupied, or dismissive are less likely to have secure traits. Consequently, the secure subscale was removed from the model and the focus was narrowed in on the insecure subscales. In accordance with the literature on fibromyalgia (Brosschot & Aarsse, 2001) the fearful attachment style was the scale that proved to have the most statistically significant impact on the construct of attachment style in this sample. The same attachment style proved to be the most present in alexithymic individuals in other studies (Montebarocci et al., 2004; Troisi et al., 2001). In the present study, more than half of the sample had poignant alexithymic features. This might explain why fearful attachment traits were found to be the most statistically significant even though the dismissing attachment style was found to be the more frequent attachment style.

Fearful attachment style implies high anxiety and high avoidance (Bartholomew & Horowitz, 1991), placing fearful individuals more at risk for inter-relational troubles. However, this hypothesis was not supported by the statistical analysis, which showed that attachment style by itself is not a mediator of the relationship between fibromyalgia impact and couple satisfaction. Even though this hypothesis was rejected, there was one important finding that emerged from testing it and it deserves highlighting: in the fibromyalgia population avoidance traits are the most prevalent traits (the dismissing and fearful attachment styles are both defined by high avoidance), with fearful attachment style being the most statistically significant. This finding raises some interesting questions: is it that individuals who have predominantly avoidant traits are more prone to

fibromyalgia, or is it that persons with fibromyalgia develop avoidant behaviors as a coping mechanism in dealing with chronic pain? Are these two aspects, having fibromyalgia and avoidant traits concurrent and influence each other? Future research about the impact of an avoidant attachment style on fibromyalgia patients can offer some answers to the questions raised above.

Hypothesis 3 & 4

Through hypothesis 4, I tested the assumption that fibromyalgia may have a direct impact on couple adjustment and satisfaction independent of the other two variables studied (attachment style and alexithymia). The structural equation modeling method showed that fibromyalgia symptoms by themselves do not have a direct impact on perceived satisfaction in my sample and could not explain the distress these individuals experience in their intimate relationships.

Eighty-nine participants (43%) in this study are severely afflicted by fibromyalgia and the scores of 84 participants (40%) showed that they were involved in distressed relationships at the time they completed the questionnaires. Overall, this sample seems to be severely affected by the disease and also somewhat unsatisfied with their intimate relationships. However, according to the statistical analysis, it seems that their suffering from fibromyalgia alone cannot explain their couple situation; the implications are that there are other variables that have to be taken into account in order to explain the dissatisfaction.

This result is consistent with findings from previous studies. As mentioned in the literature review section, there is a scarcity of research on this particular topic. However, the only study found on the relationship between fibromyalgia and marital satisfaction

showed no difference between the clinical and non-clinical population defined as pain-free and chronic illness-free (Chenall, 1999) probably suggesting that the actual syndrome does not have an impact *per se* on relationship satisfaction. Moreover, in an extensive review of the literature on chronic pain and couple satisfaction, Leonard, Cano, and Johansen (2006) found that there is little evidence for the relationship between pain severity and couple adjustment, as well as for the relationship between physical disability and the aforementioned variable. The authors did reveal that the most consistent correlation was found between couple satisfaction and psychological distress in the chronic pain population, which seems to sustain my hypothesis that there are other variables involved. The literature shows that 20-40% of the patients diagnosed with FMS are also diagnosed with depression and/or anxiety (Arnold et al., 2006; Dadabhoy & Claw, 2008; Rao, Gendreau & Kranzler, 2007). Even though there are no direct statistical correlations between fibromyalgia symptoms and couple satisfaction, it could be implied that the psychological distress this population usually reports might be related to having to manage almost daily the pain, fatigue, and other physical limitations associated with their illness.

The model that proved to have the best fit for the data collected was the one proposed in hypothesis 3, in which a combination of alexithymia and attachment style was hypothesized to mediate the relationship between the fibromyalgia impact and couple satisfaction. Based on this statistical model, it can be inferred that people diagnosed with fibromyalgia that have difficulties processing feelings and have an insecure attachment style (especially if it is the fearful attachment style) tend to perceive a lower couple satisfaction.

The literature on the social life of this population shows that fibromyalgia patients have a decreased ability to establish and maintain close emotional and physical contact with their intimate others (Arnold et al., 2008; Cunningham & Jillings, 2006; Henriksson, 1995; Stuifbergen et al., 2006), and have smaller social networks than healthy control groups (Bolwijn et al., 1994, 1996) or patients with other types of chronic pain (Davies, Zautra, & Reich, 2001; Zautra, Hamilton, & Burk, 1999). They also employ avoidant behaviors to deal with the stress of relationships (Davies, Zautra, & Reich, 2001; Geenen & van Middendorp, 2006; van Middendorp et al., 2008; Zautra, Hamilton, & Burk, 1999). The findings from the present study suggest that all these characteristics may be due to a combination of alexithymia features and insecure attachment style rather than due to fibromyalgia symptoms. If we are considering an individual who is in pain most of the time, fatigued and also having difficulties processing feelings, as well as being fraught by high anxiety and high avoidance, one can almost predict difficulties in intimate relationships, which require an ability to be open, make oneself vulnerable and stay engaged. According to the results of my study, in the case of fibromyalgia patients the impact on the relationship seems to be explained by a combination of difficulties processing feelings and high avoidance and anxiety more than the daily battling of fibromyalgia symptoms in and of themselves.

It can be argued that the combination of alexithymia and insecure attachment style can have an impact on couple satisfaction even in a non-clinical population. I believe that the high prevalence of alexithymia in the fibromyalgia population, proven to be double than in the control groups (Kokkonen et al., 2001; Posse, Hallstrom, & Backenroth-

Ohsako, 2002), and associated with a prevalence of insecure attachment styles makes it even more important to be assessed and addressed clinically.

Another finding in this study shows that there is an important correlation between the two mediating variables, alexithymia and adult attachment style, especially between the DIF (difficulty identifying feelings) and DDF (difficulty describing feelings) subscales of the alexithymia scale and insecure attachment styles. In other words, the results reveal that fibromyalgia patients who have problems identifying and describing feelings have a higher probability to have an insecure attachment style. This finding concurs with results from other studies either in symptom-free populations or in persons with mood disorders or alcoholism (De Rick & Vanheule, 2006; Malinckrodt & Vei, 2005; Montebanocci et al., 2004; Picardi, Toni, & Caroppo, 2005; Troisi et al., 2001). Moreover, in the fibromyalgia population van Middendorp and her collaborators (2008) found a positive correlation between a difficulty in processing feelings and avoidant behaviors, which can suggest the same implication. What could not be explained in my research or in general in the literature is what came first: was alexithymia first, as a personality trait that people were born with and this contributed to the development of an insecure attachment style, or rather these two aspects evolve together throughout the life span of an individual, influencing each other? And in the case of FMS, are individuals with alexithymia and insecure attachment style more prone to developing fibromyalgia or not? These are questions waiting to be answered in future studies.

Who is Emily and how is this important for the findings of this study?

I would like to go back to Emily, the woman in my introduction who suffers from fibromyalgia. According to this study, Emily seems to be a White woman, over forty years of age, heterosexual, who declares herself religious and part of a Christian denomination. She has some college education and used to work fulltime before her symptoms forced her to reduce her workload. Her household income is somewhere between \$40,000 and \$59,000. She just celebrated her 12 year marriage anniversary. Emily was diagnosed with fibromyalgia 6 years ago but experienced the symptoms longer than that, approximately for 11 years. She tried all kinds of treatments: pain medication, antidepressants, exercise, massage, some of which worked better than others but none of them provided full relief.

Even though Pearson correlation tests showed no statistically significant associations between the variables studied and the demographic data in this sample, I would like to make some observations about the make up of my sample.

Gender, Race and Fibromyalgia

The vast majority of the participants studied are women (92%). This finding is consistent with other research on this syndrome (Mease, 2008; Rao, Gendreau, & Kranzler, 2007; White, Speechley, Harth, & Ostbyte, 1999) which shows a much higher incidence of women than men suffering from fibromyalgia. We do not know yet why this difference exists. To date no specific relations between female hormonal status and fibromyalgia were identified. Some authors suggest that men may be less prone to report symptoms of pain or fatigue that can make them look ‘weak’, which is perceived as

socially unacceptable. This may be one of the reasons why men were reluctant to complete the survey for the present study.

Eighty-nine percent of the participants in this study identified themselves as White, followed by 10% Latino/Latina, 3% African-American and 3% Native-American participants. In general, studies on fibromyalgia could not identify a specific race/ethnicity with a higher morbidity for this syndrome (Hauser, Bernardy, Uceyler, & Sommer, 2009; Rao, Gendreau, Kranzler, 2007; Mease, 2008).

Some of the reasons the respondents to my research project were mainly White could be related to the administering methodology. This survey was administered via an internet posting on the National Fibromyalgia Association. In order to have access to it, the participants were supposed to have good web navigation skills, be aware of the existence of this association and its presence on the internet and then be curious enough to access the website's Research page. It may be that for African-American and Native-American people, an inclination not to trust research which has been used by white people in the past to further oppress people of color, adds to their wariness of participating in internet surveys. It may also be that these communities lean toward communal rather than individualistic life styles and would be more open to participating in research with face-to-face contact. Also, being able to read English proficiently was essential for all the steps mentioned as well as for taking the actual survey. This could explain the weak participation of a part of the Hispanic population which may not have a good command of the English language.

Aspects of education and class in fibromyalgia population

There is little data on the socio-economic status and education of fibromyalgia patients so it is difficult to present these numbers in that context. Sixty-five percent of the participants have a household income per year of \$40,000 suggesting that they come from households that are middle class or higher. This finding may be also correlated with the level of education found amongst the participants.

The majority of the subjects in this study (72%) had at least some college education if not a college degree, and another 15% had a graduate level education. This is another characteristic that was not necessarily addressed in epidemiological studies. These two aspects may be directly correlated to the administration of this survey on the internet. As mentioned previously, in order to take the survey, the potential participants needed to have good computer skills, access to a computer and to the internet. Unfortunately, it can be reasonably inferred that lower income and less educated fibromyalgia patients did not have equal access to taking this survey.

Thus, it make sense that a woman with Emily's characteristics would be likely to participate in the present study, especially now being home a lot, after she was forced to work only part-time due to her increasing pain and fatigue. Coming from a typical middle-class household, it is also likely that Emily would have a computer at home and access to internet.

Another explanation could be that due to social desirability people reported being more educated and situated themselves in a higher household income bracket than they really are. The latter seems less probable due to the anonymity of this study and the fact

that I actually had no contact with the participants. This issue will be addressed in the section discussing the limitations of this study.

Relational characteristics

One of the two requirements for participating in this study was to be in a long-term intimate relationship. I left the definition of what constitutes intimate and long-term purposefully open so that the participants would feel free to evaluate for themselves if they qualified for this study, since different individuals have different understandings of these concepts. The other, more precise variable was having a diagnosis of fibromyalgia.

In my sample, 68% of the participants were married and the average time in the relationship was 12 years, with the longest relationship being 54 years. The large majority identified themselves as heterosexual (92%) and the rest as either bisexual (7%) or homosexual (1%). Based on their RDAS scores, 84 participants (40%) were involved in distressed relationships at the time of the study. According to the model that proved to be a good fit for the data (see fig 12), this relatively high percentage may be explained by the high percentage of participants who have scores that place them in the alexithymia spectrum (52%), as the relationship between alexithymia and couple satisfaction is a negative one (higher alexithymia scores correlate with lower RDAS scores/distressed relationships). The combination between alexithymia and an insecure attachment style can explain this relationship even stronger. However, my sample scored as generally more satisfied than the participants in Steinberg's (2007) study, in which only 15% were able to maintain a long-term relationship. The differences can be due to the small sample size in Steinberg's (2007) study (12 participants) which makes the results less generalizable.

It seems that even though 95% of the sample scored as being moderately and severely afflicted by fibromyalgia, this fact alone cannot explain the high percentage of distressed couples in this sample. The explanation seems to reside in the impact of the combination of the two mediating variables (alexithymia and attachment style). It would be interesting to see if the same correlations can be found in a sample that scores lower on fibromyalgia impact since in the present study I found a positive path between fibromyalgia impact and alexithymia and attachment style (more severely afflicted individuals seem to have higher levels of alexithymia as well as an insecure attachment style).

Another aspect that needs addressing is the high percentage of participants that scored 61 and higher on the alexithymia scale, placing them in the alexithymic population. In my study I found that 52% of the sample can be considered alexithymic. This is a much higher percent than those reported in the literature where only 15% of the fibromyalgia patients were found to be alexithymic (Dadabhoy & Claw, 2008; Pedrosa et al., 2008; Rao, Gendreau, & Kranzler, 2007). I have a few possible explanations for this characteristic of the present sample: being an internet survey and the probability to identify the patients is very minimal, and the participants felt freer to be honest than in a pen and paper administered test where there is more contact with individuals involved in studies. This implies that the actual percentage of alexithymia in the fibromyalgia population may be higher.

Another explanation related to the same aspect of the methodology is that people who are more alexithymic are more prone to spending time on the computer. De Berardis and his colleagues (2009) found that alexithymic individuals spend more time on the

computer and are more at risk for Internet addiction than their non-alexithymic counterparts. Moreover, from the literature on alexithymia and fibromyalgia it can be noticed that this fraction of the population tends to employ avoidant behaviors (van Middendorp et al., 2008). Part of these behaviors may be avoiding direct relationship contact through spending time on the computer.

In this context, it would be very important that Emily's couple therapist assesses the presence of alexithymia and also her attachment style. This would help contextualize some of her husband's complains about her avoiding sexual relations, complains mentioned in the introductory vignette, especially if she is severely affected by fibromyalgia symptoms.

Chapter 6: Clinical Implications and Future Research

Clinical Implications

In my introductory vignette, Emily's PCP suggested she should seek couple counseling if the problems with her husband persist. Let's say that Emily becomes more and more frustrated with her relationship and decides to get help from a couple's therapist. Her PCP's suggestion seems to be the correct one, especially because studies have shown repeatedly the positive impact of social support on health outcomes in people with fibromyalgia in both qualitative and quantitative research (Bolwijn et al., 1994, 1996; Davies, Zautra, & Reich, 2001; Henriksson, 1995; Preece & Sandberg, 2005; Steinberg, 2007; Stuifbergen et al., 1996). Moreover, some of these studies have demonstrated that patients with fibromyalgia rely mostly on their families and close friends and have small support groups compared with those afflicted by other chronic pain conditions (Bolwijn et al., 1994, 1996). All these findings support the importance and stringency of addressing couple concerns of patients with fibromyalgia. In addition, there are several clinical implications that stem directly from this study that Emily's couple therapist should be aware of.

First of all, mental health professionals working with clients afflicted by this syndrome, including couple's therapists, should be aware of what a diagnosis of fibromyalgia entails (pain, fatigue, 'fibro fog', loss of memory, and sleep disturbances) and how these symptoms can affect one's daily routines and relational lives. These professionals should also be aware of the significant co-morbidity with anxiety and depression, which are present in 20% to 40% of the cases (Arnold et al., 2006; Dadabhoy & Claw, 2008; Rao, Geandreau, & Kranzler, 2007) and should actively assess for

symptoms of these disorders. Furthermore, couple therapists should also be aware of studies that show the impact of the syndrome on the spouses' well-being (Bigatti & Cronan, 2002). This knowledge would provide mental health professionals with a better understanding of their clients' experiences, paving the foundation for an effective therapeutic relationship.

Second, Emily's couple therapist should familiarize her/himself with the results of this study in order to understand the interaction between alexithymia features and attachment style in determining couple satisfaction for fibromyalgia patients. According to this study, it would be particularly relevant if Emily would be found to have difficulties processing feelings and a fearful attachment style. The interplay between her challenges in describing to her husband how she is feeling and picking up clues about how he is feeling, as well as the 'dance' between wanting to be close to her loved one but being afraid of being hurt and consequently withdrawing (fearful attachment style), can pose problems even in relationships that are not plagued by fibromyalgia. When there is pain, fatigue, and sleepless nights added to this emotional 'dance', the pressure on the intimate relationship may be even greater.

However, the results of this study have suggested that the distress in the couple relationship of fibromyalgia patients cannot be blamed on their FMS symptoms. It is rather correlated with the presence of alexithymia and insecure attachment styles. This piece of knowledge can be very important when working with Emily and her husband because the focus of the sessions should be on the emotional aspects of the relationship rather than the day to day management of fibromyalgia for a successful outcome. Thus, I

would suggest that an emotionally-focused couple therapist would be a very good fit for working with Emily and her husband.

Emotionally Focused Therapy (EFT) is an empirically supported, attachment based therapeutic model that integrates systemic/humanistic and experiential approaches to clinical work with couples (Johnson, 2004). It also integrates an intrapsychic focus on how individuals process their experience with the relational aspect. EFT uses attachment theory as the basis for understanding adult love. Four important tenets of this model are:

- a) The key issue in marital conflict is the security of the emotional bond.
- b) Emotions are the key organizing principle for attachment behaviors and the way the self and others are experienced in intimate relationships.
- c) The attachment needs and desires of individuals are essentially healthy and adaptive
- d) Change is associated with the accessing and reprocessing of the emotional experience underlying each partner's position in the relationship (Johnson, 2004).

“The main focus of EFT is to help couples create bonding moments where core attachment needs (closeness, connection, safety/security) are met for both partners. The pathway to attachment needs is through emotion; therefore, the clinician's job is to help couples identify and access unacknowledged emotions that lie at the root of negative interactional cycles. Once a partner is able to access and describe her/his own emotional experience and attachment needs, the therapist helps the client ask her/his partner for the closeness and connection needed” (Ungureanu & Sandberg, 2010, p. 314).

Due to its emphasis on emotional experiences and its psychoeducational aspects in regards to processing feelings, this approach to couple's therapy seems to be very well suited in working with fibromyalgia sufferers and their partners, especially those with alexithymia features and insecure attachment styles. Moreover, EFT was proposed to be a useful intervention in couples dealing with chronic illness (Stiell, Naaman, & Lee, 2007) because securely bonded couples in satisfying relationships are afforded numerous physical and mental health benefits (Burman & Margolin, 1992; Kiecolt-Glaser & Newton, 2001; Stiell, Naaman, & Lee, 2007).

Limitations of the study

Although this study is an important contribution to the field because it provides information about unique mediation processes of alexithymia and attachment style on couple adjustment in the fibromyalgia population, there are still important limitations of my research that need to be addressed. The most important limitation includes the difficulty to generalize findings beyond the white female population afflicted by this syndrome. The vast majority of the participants (92%) were females and the majority of them (93%) identified themselves as White. It is obvious there is a need for a more diverse sample. Epidemiological studies have not shown that fibromyalgia is related to the White genotype (Mease, 2008; Rao, Gendreau, & Kranzler, 2007), but that the disease afflicts equally other races and ethnicities. The convenience sampling used in this study limits its external validity and reliability and contributes to the generalizing difficulties. Thus, future research should address this issue. One way to address this problem may be changing the methodology of collecting the data. Data collected from

participants approached at Fibromyalgia Clinics around the country may offer a better racial representation.

Another limitation is related to the relatively small number of participants. Although the number employed in my study was statistically appropriate for the analysis used (SEM; Kline, 2005), it is probably not enough to apply the findings to the general fibromyalgia population, especially when considering the homogeneity of the sample. Future researchers should make every effort to employ a larger and more diverse sample in order to ensure the generalizability of the findings.

Using exclusively self-report questionnaires has its own limitations, especially related to issues of validity (Stone, Bachrach, Jobe, Kurtzman, & Cain, 1999). One of them is the social desirability bias. Even though I used scales that are widely used in research and their reliability and validity are strong, the self-report questionnaires will also be plagued by the social desirability bias: we all have a tendency to give answers that seem more socially acceptable. Participants also can forget some details about their experiences and so give a skewed answer. Furthermore, the answers to a self-report questionnaire are influenced by the person's feelings and state of mind at the time of taking the survey: if the respondents feel well, their answers will be more positive, if the respondents do not feel so positive at the time of taking the survey, the answers can be more negative (Stone et al., 1999). In the fibromyalgia population this aspect can be particularly relevant due to the characteristic of the symptomatology: chronic pain, fatigue, and 'fibro fog'.

One of the ways to improve limitations related to the analysis method would be the use of control groups. In my study one of the limitations is related to the focus on

alexithymic and insecure attached individuals diagnosed with fibromyalgia. A comparison of this segment with fibromyalgia suffering people that do not have alexithymia features and are securely attached would provide more information on how these two variables mediate the relationship between the FMS impact and couple satisfaction. Furthermore, comparing this sample with the general, non-clinic population would show even more of the effects of alexithymia and attachment style on the dyadic adjustment.

Future research

As Campbell stated in his comprehensive article on family interventions for physical disorders, “we are just beginning to understand what family characteristics are important in physical health and how they influence health” (Campbell, 2003, p. 275). I would add that we are just beginning to understand the influence of physical disorders on couple and family dynamics as well. My study was a survey research project on the influence of fibromyalgia on couple relationships and how this relationship is mediated or not by emotional features of the patient with the syndrome. While my study contributed to the expansion of knowledge on characteristics of marital relations there is still much work to be done in order to have a clearer picture of the dynamics of couple relationship in this population to help us, marriage and family therapists provide them with the best services.

Future research that would offer further insight into couple satisfaction in the fibromyalgia population needs to include more diversity. In my study the majority of the participants were White middle class heterosexual females. Future studies should make

sure to include participants with different races, ethnicities, social class, and sexual orientation.

Because fibromyalgia is much more frequent in women than in men, research like mine that uses a convenience sampling method usually ends up with a majority of female participants. It would be interesting to study specifically how men suffering from FMS perceive their couple relationship and in what ways it is different (or not) than women with the same symptoms perceive it. It would also be interesting to study if the percentages of alexithymic patients would be the same or different for men than for women, as it is known that in the general population that alexithymia is more prevalent in men than in women (Kokkonen, Karvonen, Veijola, Laksi, & Jokelainen, 2001; Posse, Hallstrom, & Backenroth-Ohsako, 2002).

Another way of furthering the knowledge would be to employ a mixed methodology for analyzing the data (quantitative and qualitative). In addition to the data processed quantitatively, qualitative questionnaires with open ended questions about the participants' lived experiences of their symptoms and their impact on the couple relationship, as well as questions related to processing feelings and attachment styles could provide a more nuanced insight into the couple's life of fibromyalgia afflicted people. Qualitative interviews could also provide more specificity and detail about the day to day juggling of chronic pain and its impact on intimate relationships.

An even clearer idea about the couple relationship can be obtained through dyadic data analysis (Kenny, Kashy, & Cook, 2000) where questionnaires are applied to both fibromyalgia patients and their partners and then the data obtained is processed

conjointly. In this way, the findings would reflect a combined perception of both partners and arguably a more realistic state of the affairs in the dyads.

There is a definite need for more interventional research in the field of marriage and family therapy (Campbell, 2003). It would be useful to know if couples therapy would improve the scores on the RDAS. An experiential design, measuring especially this variable before and after the intervention could clarify the effectiveness of couple therapy in this population. Furthermore, measuring the FIQ scores before and after the intervention could show if a better dyadic adjustment has an impact on health outcomes as well.

As stated previously, EFT would be one of the couple therapy models that seems a good fit especially for the fibromyalgia patients with an insecure attachment style and alexithymia features. In addition to measuring the RDAS scores it would be interesting to know if EFT can improve the scores on alexithymia through its psychoeducational aspects related to processing feelings, and if in turn this would have an impact on the health outcomes.

In conclusion, there are many more facets of the interplay between alexithymia features and an insecure attachment style in the lives of couples dealing with fibromyalgia symptoms on a daily basis, that await to be studied. The present study was only a step forward in the journey of a comprehensive understanding of the couple's life of people afflicted by this syndrome.

APPENDIX A

Script for National Fibromyalgia Association website: Project title: Fibromyalgia syndrome: The relationship between alexithymia and attachment style on couple relationship.

Description:

This study will evaluate the quality of committed relationship in couples where at least one of the partners is diagnosed with fibromyalgia. We will look into how alexithymia (a condition that affects our ability to recognize and describe emotions) and attachment style (how people behave in intimate relationships) influence couple satisfaction when fibromyalgia symptoms are present in the daily life events.

APPENDIX B

CONSENT FORM

Project title: Fibromyalgia syndrome: The relationship between alexithymia and attachment style on couple relationship.

My name is Ileana Ungureanu, and I am a doctoral student at Syracuse University. I also hold an MD from the University of Medicine and Pharmacy, Timisoara, Romania. I am inviting you to participate in a research study. Involvement in this study is voluntary. Therefore, you may refuse to take part in the survey and you may withdraw at any time without penalty. I will explain the study in this consent form and I encourage you to ask any questions you may have over email at iungurea@syr.edu. I am interested in learning about the quality of committed relationship in couples where at least one of the partners is diagnosed with fibromyalgia. You will be asked to answer questions in four questionnaires. The first is an evaluation of the impact of fibromyalgia symptoms on your daily life. The second evaluates alexithymia (a condition that affects our ability to recognize and describe emotions), while the third one is an adult attachment style questionnaire, which is designed to show how people behave in intimate relationships. The fourth questionnaire evaluates the quality of your long-term relationship. As a reward for your participation in this study, you will be entered into a raffle to receive one of three \$50 gift certificates to a local massage clinic. The approximate odds of receiving one of the four gift certificates are 1/50. If you are one of the winners, you will receive the gift certificate via email to the address you specified entering the raffle. Only participants that complete the study will be entered in the raffle for the gift cards.

Taking the survey will take approximately 30 minutes. This survey is anonymous. The data collection method used on surveymonkey.com does not allow responses to be connected with a particular participant. The only email addresses I will have access to, are the addresses provided by you to be introduced in the raffle. However, the internet network is not 100% secure. The administrators at surveymonkey.com employ multiple layers of security to make sure that the account and the data remains private and secure. They employ a third-party firm to conduct daily audits of the security, and the data resides behind the latest in firewall and intrusion prevention technology, to insure that the data is collected in an encrypted environment.

You will be asked to provide some demographic data (gender, age, race, occupation, religion). The benefit of this research is that you may help advance the knowledge of the impact of fibromyalgia symptoms, a domain where little is known to date. Through this study you may help fibromyalgia suffering people be more visible. A possible risk of taking this survey might be emotional discomfort with the subject. Should any such discomfort arise, you can stop taking the survey, and you can email me. I will do my best to identify local agencies that provide psychotherapeutic services.

Please feel free to contact me or my advisor with any questions. I can be reached by phone at 315-443-3023 or by email at iungurea@syr.edu. My advisor, Linda Stone Fish can be reached by phone at 315-443-3024 or by email at flstone@syr.edu.

The Syracuse University Institutional Review Board (IRB) has approved this research study. If you wish, you may contact them with questions regarding your rights as participants. If you have questions, concerns, or complains, or if you want to talk to

someone other than the investigators please call 315-443-3013 to speak with an IRB representative.

Please print a copy of this consent script for your records.

Clicking bellow indicates that I have read the description of the study, I am 18 or older, and I agree to participate.

APPENDIX C

Fibromyalgia Impact Questionnaire (Burckhardt, Clark, & Bennett, 1997)

1. For questions ‘a’ through ‘k’, please check the option that best describes how you did overall, for the past week. If you normally don’t do something that is asked, place an ‘X’ in the ‘Not Applicable’ box.

Where you able to:	always				never	N/A
	0	1	2	3		
a. Do shopping	0	1	2	3		
b. Do laundry with a washer and dryer?	0	1	2	3		
c. Prepare meals?	0	1	2	3		
d. Wash dishes by hand?	0	1	2	3		
e. Vacuum a rug?	0	1	2	3		
f. Make beds?	0	1	2	3		
g. Walk several blocks?	0	1	2	3		
h. Visit friends or relatives?	0	1	2	3		
i. Do yard work?	0	1	2	3		
j. Drive a car?	0	1	2	3		
k. Climb stairs?	0	1	2	3		

2. Of the 7 days in the past week, how many days did you feel good?

3. How many days last week did you miss work, including housework, because of fibromyalgia?

For the remaining items, mark the point that best indicates how you felt overall for the past week:

4. When you worked how much did pain or other symptoms of your fibromyalgia interfere with your ability to do work, including housework?

No problem with work Great difficulty
0 ----- 10

APPENDIX D

20-item Toronto Alexithymia Scale (Bagby, R.M., Parker, J.D.A., & Taylor, G.J., 1994):

Please read each of the following statements and rate the extent to which you believe they best describe you:

	Strongly disagree				Strongly agree
1. I am often confused about what emotion I am feeling	1	2	3	4	5
2. It is difficult for me to find the right words for my feelings	1	2	3	4	5
3. I have physical sensations that even doctors do not understand	1	2	3	4	5
4. I am able to describe my feelings easily	1	2	3	4	5
5. I prefer to analyze problems rather than just describe them	1	2	3	4	5
6. When I am upset I do not know if I am sad, frightened, or angry	1	2	3	4	5
7. I am often puzzled by sensations in my body	1	2	3	4	5
8. I prefer to just let things happen rather than to understand why they turned out that way	1	2	3	4	5
9. I have feelings that I can't quite identify	1	2	3	4	5
10. Being in touch with emotions is essential	1	2	3	4	5
11. I find it hard to describe how I feel about	1	2	3	4	5

people

- | | | | | | |
|--|---|---|---|---|---|
| 12. People tell me to describe my feelings more | 1 | 2 | 3 | 4 | 5 |
| 13. I don't know what's going on inside me | 1 | 2 | 3 | 4 | 5 |
| 14. I often don't know why I am angry | 1 | 2 | 3 | 4 | 5 |
| 15. I prefer talking to people about their daily activities rather than their feelings | 1 | 2 | 3 | 4 | 5 |
| 16. I prefer to watch 'light' entertainment shows rather than psychological dramas | 1 | 2 | 3 | 4 | 5 |
| 17. It is difficult for me to reveal my innermost feelings, even to close friends | 1 | 2 | 3 | 4 | 5 |
| 18. I can feel close to someone, even in moments of silence | 1 | 2 | 3 | 4 | 5 |
| 19. I find examination of my feelings useful in solving personal problems | 1 | 2 | 3 | 4 | 5 |
| 20. Looking for hidden meanings in movies or plays distracts from their enjoyment. | 1 | 2 | 3 | 4 | 5 |

APPENDIX E

Relationship Scales Questionnaire (Griffin & Bartholomew, 1994)

Please read each of the following statements and rate the extent to which you believe they best describes you in close relationships.

	Not at all				Very like me
	Like me				
1. I find it difficult to depend on other people	1	2	3	4	5
2. It is very important to me to feel independent	1	2	3	4	5
3. I find it easy to get emotionally close to others	1	2	3	4	5
4. I want to merge completely with another person	1	2	3	4	5
5. I worry that I will be hurt if I allow myself to become too close to others	1	2	3	4	5
6. I am comfortable without close emotional relationships	1	2	3	4	5
7. I am not sure that I can always depend on others to be there when I need them	1	2	3	4	5
8. I want to be completely emotionally intimate with others	1	2	3	4	5
9. I worry about being alone	1	2	3	4	5
10. I am comfortably depending on other people	1	2	3	4	5
11. I often worry that romantic partners don't really love me	1	2	3	4	5
12. I find it difficult to trust others completely	1	2	3	4	5
13. I worry about others getting too close to me	1	2	3	4	5
14. I want emotionally close relationships	1	2	3	4	5
15. I am comfortable having other people depend on me	1	2	3	4	5

16. I worry that others don't value me as much as I value them	1	2	3	4	5
17. People are never there when you need them	1	2	3	4	5
18. My desire to merge completely sometimes scares people away	1	2	3	4	5
19. It is very important to me to feel self-sufficient	1	2	3	4	5
20. I am nervous when anyone gets too close to me	1	2	3	4	5
21. I often worry that romantic partners won't want to stay with me	1	2	3	4	5
22. I prefer not to have other people depend on me	1	2	3	4	5
23. I worry about being abandoned	1	2	3	4	5
24. I am uncomfortable being close to others	1	2	3	4	5
25. I find that others are reluctant to get as close as I would like	1	2	3	4	5
26. I prefer not to depend on others	1	2	3	4	5
27. I know that others will be there when I need them	1	2	3	4	5
28. I worry about having others not accept me	1	2	3	4	5
29. Romantic partners often want me to be closer than I feel comfortable being	1	2	3	4	5
30. I find it relatively easy to get close to others	1	2	3	4	5

APPENDIX F

Revised Dyadic Adjustment Scale (Busby, Crane, Larson, & Christensen, 1995)

Most persons have disagreements in their relationships. Please indicate below the approximate extent of agreement or disagreement between you and your partner for each item on the following list.

	Always agree			Always disagree		
1. Religious matters	5	4	3	2	1	0
2. Demonstration of affection	5	4	3	2	1	0
3. Making major decisions	5	4	3	2	1	0
4. Sex relations	5	4	3	2	1	0
5. Conventionality (correct or proper behavior)	5	4	3	2	1	0
6. Career decisions	5	4	3	2	1	0
	All the time			Never		
7. How often do you discuss or have you considered divorce, separation, or terminating your relationship?	0	1	2	3	4	5
8. How often do you and your partner quarrel?	0	1	2	3	4	5
9. Do you ever regret that you married (or lived together)?	0	1	2	3	4	5
10. How often do you and your mate 'get on each other's nerves'?	0	1	2	3	4	5

	every day				never	
	4	3	2	1	0	
11. Do you and your mate engage in outside interests together?						
How often would you say the following events occur between you and your mate?						

	Never				Often	
	0	1	2	3	4	5
12. Have a stimulating exchange of ideas						
13. Work together on a project						
14. Calmly discuss something						

APPENDIX G

DEMOGRAPHIC QUESTIONNAIRE

1. Please list your e-mail address if you wish to be entered into a drawing for one of the three \$50 gift certificates to a local massage clinic (your email address will be used ONLY for the raffle selection purposes).
2. Age:
 - a) 18-24
 - b) 25-35
 - c) 36-45
 - d) 45-55
 - e) 56- older
3. Gender
 - a) Female
 - b) Male
4. Race/ethnicity:
 - a) Native American
 - b) Black
 - c) White
 - d) Latino/Latina
 - e) Native Hawaiian or other Pacific Islander
 - f) Other – Please specify
5. Are you religiously affiliated? If so what affiliation?
6. Sexual orientation:
 - a) Heterosexual
 - b) Homosexual
 - c) Bisexual
 - d) Not sure
7. Occupation status:
 - a) Full-time work
 - b) Part-time work
 - c) Student
 - d) Unemployed
 - e) Retired
 - f) Active military duty
 - g) Other – please specify

8. Education status:
 - a) Less than high-school
 - b) High-school
 - c) Some college education
 - d) College degree
 - e) Graduate level

9. Relationship status:
 - a. Never married
 - b. Married
 - c. Living with someone
 - d. In a intimate relationship

10. Months/years in the present relationship:

11. Household Income:
 - a) Bellow 20,000
 - b) 20,000-39,000
 - c) 40,000-59,000
 - d) 60,000-79,000
 - e) 80,000-99,000
 - f) 100,000 or more

12. Duration of FM symptoms (months/years)

13. Months/Years since diagnosis with FM

14. Treatment for FM:
 - a. None
 - b. Pain medication
 - c. Muscle relaxants
 - d. Antidepressants
 - e. Exercise
 - f. Massage
 - g. Physical therapy
 - h. Chiropractic
 - i. Alternative medicine (acupuncture, zone therapy, etc)
 - j. Psychotherapy

REFERENCES

- Ainsworth, M.D.S., Blehar, M.C., Waters, E. & Wall, S. (1978). *Patterns of attachment: A psychological study of the strange situation*. Hillsdale, NJ: Erlbaum.
- Alfieri, S., Sigal, M., & Landau, M (1989). Primary fibromyalgia syndrome: A variant of depressive disorder. *Psychotherapy and Psychosomatics*, 51, 156-1961.
- Affleck, G., Tennen, H., Urrows, S., Higgins, P., Abeles, M., Hall, C., Karoly, P., & Newton, C. (1998). Fibromyalgia and women's pursuit of personal goals: A daily process analysis. *Health Psychology*, 17, 40-47.
- Anders, S.L., & Tucker, J.S. (2000). Adult attachment style, interpersonal communication competence, and social support. *Personal Relationships*, 7, 379-389.
- Anderson, D.J., & Hines, R.H. (1994). Attachment and pain. In R.C. Grzesiak & D.S. Ciccone (Eds), *Psychosocial vulnerability to chronic pain (137-152)*. New York: Springer.
- Arbuckle, J.L., & Wothke, W. (1999). *AMOS 4.0: User's guide*. Chicago: Smallwaters.
- Arnold, L.M., Hudson, J. I., Keck, P. E., Auchenbach, M. B., & Pope, H.G. (2004). Family study of fibromyalgia and affective spectrum disorders. *Biological psychiatry*, 56 (11), 884-891.
- Arnold, L. M., Hudson, J. I., Keck, P. E., Auchenbach, M. B., Javaras, K. N., & Hess, E. V. (2006). Comorbidity of fibromyalgia and psychiatric disorders. *Journal of Clinical Psychiatry*, 67(8), 1219-1225.
- Arnold, L.M., Crofford, L.J., Mease, P.J., Burgess, S.M., Palmer, S.C., Abetz, L., & Martin, S.A. (2008). Patient perspectives on the impact of fibromyalgia. *Patient Education and Counseling*, 73, 114-120.
- Asbring, P., & Narvanen, A-L. (2002). Women's Experiences of stigma in relation to chronic fatigue syndrome and fibromyalgia. *Qualitative Health Research*, 12(2), 148-160.
- Bagby, R.M., Parker, J.D.A., & Taylor, G.J. (1994). The twenty-item Toronto Alexithymia Scale-I. Item selection and cross-validation of the factor structure. *Journal of Psychosomatic Research*, 38, 23-32.
- Bagby, R.M., & Taylor, G.J. (1997). Affect dysregulation and alexithymia. In G.J. Taylor. In R.M Bagby, & J.D.A Parker (Eds). *Disorders of affect regulation: Alexithymia in medical and psychiatric illness*(26-45). Cambridge, UK: Cambridge University Press.

- Banks, S.M., Kerns, R.D. (1996). Explaining high rates of depression in chronic pain: A diathesis-stress framework. *Psychological Bulletin*, 119, 95-110.
- Banse, R (2004). Adult attachment and marital satisfaction. Evidence for dyadic configuration effects. *Journal of Social and Personal Relationships*, 21, 273-282.
- Bartholomew, K. (1990). Avoidance of intimacy: An attachment perspective. *Journal of Social and Personal Relationships*, 7, 147-178.
- Bartholomew, K., & Horowitz, L.M. (1991). Attachment styles among young adults: A test of a four-category model. *Journal of Personality and Social Psychology*, 61(2), 226-244.
- Bartholomew, K., & Moretti, M. (2002). The dynamics of measuring attachment. *Attachment & Human Development*, 4(2), 162-165.
- Bartholomew, K. (2011). Frequently Asked Questions. Retrieved March 25, 2011, <http://www.sfu.ca/psyc/faculty/bartholomew/faq.htm>.
- De Berardis, D., D'Albenzio, A., Gambi, F., Sepede, G., Valchera, A., Conti, C.M., Fulcheri, M., Cavuto, M., Ortolani, C., Salerno, R.M., Serroni, N., & Ferro, F.M. (2009). Alexithymia and its relationships with dissociative experiences and Internet addiction in a non-clinical sample. *CyberPsychology & Behavior*, 12(1), 67-69.
- van Berlo, W.T.M., Vennix, P., Rasker, J.J., van Rijswijk, M.H., Taal, E., & Schultz, W.C.M.W. (1999). Rheumatic disease and sexuality: A review of the literature. *Rheumatology in Europe*, 28, 113-117.
- Bigatti, S.M (2000). Relationships between perceived burdens, physical health, and health care use among spouses of people with fibromyalgia syndrome. *Dissertation Abstracts International; Section B; The Sciences and Engineering*; vol. 61(5-B), p. 2746.
- Bigatti, S.M., & Cronan, T.A. (2002). An examination of the physical health, health care use, and psychological well-being of spouses of people with fibromyalgia syndrome. *Health Psychology*, 21(2), 157-166.
- Block, A.R., & Boyer, S.L (1984). The spouse's adjustment to chronic pain: Cognitive and emotional factors. *Social Science & Medicine*, 19(12), 1313-1317.
- Boisset-Pioro, M.H., Esdaile, J.M., & Fitzcharles, M. A. (1995). Sexual and physical abuse in women with fibromyalgia syndrome. *Arthritis and Rheumatism*, 30(2), 235-241.

- Bowlby, J. (1977). The making and breaking of affectional bonds. *British Journal of Psychiatry*, 130, 201-210.
- Bowlby, J. (1979). *The making and breaking of affectional bonds*. London: Tavistock.
- Bowlby, J. (1982). *Attachment and loss: Vol. I. Attachment*(2nd). New York: Basic Books.
- Bolwijn, P.H., van Santen-Hoeufft, M.H.S., Baars, H.M.J., Kaplan, C.D., & van der Linden, S. (1996). The social network characteristics of fibromyalgia patients compared with healthy controls. *Arthritis Care and Research*, 9(1), 18-26.
- Bolwijn, P.H., van Santen-Hoeufft, M.H.S., Baars, H.M.J., & van der Linden, S. (1994). Social network characteristics in fibromyalgia or rheumatoid arthritis. *Arthritis Care and Research*, 7(1), 46-49.
- Borman, P. (1999). A comparative analysis of quality of life in rheumatoid arthritis and fibromyalgia. *Journal of Musculoskeletal Pain*, 7(4), 5-14.
- Brosschot, J.F., & Aarsse, H.A. (2001). Restricted emotional processing and somatic attribution in fibromyalgia. *International Journal of Psychiatry in Medicine*, 31(2), 127-146.
- Burman, B., & Margolin, G. (1992). Analysis of the association between marital relationships and health problems: An interactional perspective. *Psychological Bulletin*, 112, 39-63.
- Busby, D.M., Crane, D.R., Larson, J.H., & Christenses, C. (1995). A revision of the Dyadic Adjustment Scale for use with distressed and nondistressed couples: Construct hierarchy and multidimensional scales. *Journal of Marital and Family Therapy*, 21(3), 289-308.
- Byrne, B.M. (2001). *Structural equation modeling with AMOS: Basic concepts, applications, and modeling*. New Jersey: Lawrence Erlbaum Associates.
- Campbell, T.L. (2003). The effectiveness of family interventions for physical disorders. *Journal of Marital and Family Therapy*, 29(3), 263-281.
- Cano, A., Weisberg, J.N., & Gallagher, R. M. (2000). Marital satisfaction and pain severity mediate the association between negative spouse responses to pain and depressive symptoms in a chronic pain patient sample. *Pain Medicine*, 1, 35-43.
- Cano, A., Gillis, M., Heinz, W., Geisser, M., Foran, H. (2004). Marital functioning, chronic pain, and psychological distress. *Pain*, 107, 99-106.

- Carnelley, K.B., Pietromonaco, P.R., & Jaffe, K. (1996). Attachment, caregiving, and relationship functioning in couples: Effects of self and partner. *Personal Relationships, 3*, 257-277.
- Cassidy, J., & Shaver, P.R. (2008). *Handbook of attachment: Theory, research, and clinical applications*. New York: The Guilford Press.
- Chenhall, P.J (1999). Family functioning and marital satisfaction reported by women with fibromyalgia, their spouses, and control groups. *Dissertation Abstracts International; Section B; The Sciences and Engineering; vol. 59 (10-B)*, p. 5572.
- Ciccone, D. S., Elliott, D. K., Chandler, H. L., Nayak, S., & Raphael, K.G. (2005). Sexual and physical abuse in women with fibromyalgia syndrome: A test of the trauma hypothesis. *Clinical Journal of Pain, 21 (5)*, 378-386.
- Collins, N.L., & Read, S.J. (1990). Adult attachment, working models, and relationship quality in dating couples. *Journal of Personality and Social Psychology, 58*, 644-663.
- Crane, D.R., Middleton, K.C., & Bean, R.A. (2000). Establishing criterion scores for the Kansas Marital Satisfaction Scale and the Revised Dyadic Adjustment Scale. *American Journal of Family Therapy, 28*, 53-60.
- Cunningham, M.M., & Jillings, C. (2006). Individuals' description of living with fibromyalgia. *Clinical Nursing Research, 15(4)*, 258-273.
- Cymet, T. C. (2003). A practical approach to fibromyalgia. *Journal of the National Medical Association, 95(4)*, 278-285.
- Dadabhoy, D., & Clauw, D. J. (2008). The fibromyalgia syndrome. In J. H Klippel, J. H Stone, L.J Crofford, & P. H White (Eds). *Primer on the Rheumatic Diseases (87-93)*. New York: Springer.
- Davis, M.W., Morris, M.M., & Kraus, I.A. (1998). Relationship-specific and global perceptions of social support, association with well-being, and attachment. *Journal of Personality and Social Psychology, 74*, 468-481.
- Davis, M.C., Zautra, A.J., & Reich, J.W. (2001). Vulnerability to stress among women in chronic pain from fibromyalgia and osteoarthritis. *Annals of Behavioral Medicine, 23(3)*, 215-226.
- De Rick, A., & Vanheule, S. (2006). The relationship between perceived parenting, adult attachment style and alexithymia in alcoholic inpatients. *Addictive Behaviors, 31*, 1265-1270.

- Engel, G. L. (1977). The need for a new medical model: A challenge for biomedicine. *Science*, 196 (4286), 129-136.
- Espina Eizaguirre, A. (2002). Alexitmia y relaciones de pareja. *Psicothema*, 14(4), 760-764.
- Feeney, J.A. (1996). Attachment, caregiving, and marital satisfaction. *Personal Relationships*, 3, 401-416.
- Feeney, J.A. (1998). Adult attachment and relationship-centered anxiety: Response to physical and emotional distancing. In J.A Simpson and W.S. Rholes (Eds). *Attachment theory and close relationships* (189-218). New York: The Guilford Press.
- Feeney, J.A. (2002). Attachment, marital interaction, and relationship satisfaction: A diary study. *Personal Relationships*, 9, 39-55.
- Feeney, J.A. (2008). Adult romantic attachment: Developments in the study of couple relationships. In J. Cassidy & P.R. Shaver (Eds). *Handbook of attachment: Theory, Research, and Clinical Applications*(456-481). New York: The Guilford Press
- Feeney, J.A., Noller, P., & Callan, V.J. (1994). Attachment style, communication, and satisfaction in the early years of marriage. In K. Bartholomew & D. Perlman (Eds.). *Advances in personal relationships: vol. 5, Attachment processes in adulthood* (269-308). London: Jessica Kingsley.
- Feeney, J.A., Noller, P., & Hanrahan, M. (1994). Assessing adult attachment. In M.B. Sperling & W.H Berman (Eds). *Attachment in adults. Clinical and developmental perspectives*. New York: The Guilford Press.
- Feeney, J.A., & Ryan, S.M. (1994). Attachment style and affect regulation: Relationships with health behavior and family experiences of illness in a student sample. *Health Psychology*, 13(4), 334-345.
- Feeney, J.A. (1995). Adult attachment, coping style, and health locus of control as predictors of health behavior. *Australian Journal of Psychology*, 47, 171-177.
- Feeney, B.C., & Collins, N.L. (2004). Interpersonal safe haven and secure base caregiving processes in adulthood. In W.S Rholes & L. Simpson (Eds). *Adult attachment: Theory, research, and clinical implications* (300-338). New York: The Guilford Press.
- Feldman, M P (2007). Fibromyalgia and social support: An overlooked connection. *Dissertation Abstracts International; Section B; The Sciences and Engineering*; vol. 68(3-B), p.1923

- Flor, H., Turk, D.C., & Scholtz, O.B. (1987). Impact of chronic pain on the spouse: Marital, emotional, and physical consequences. *Journal of Psychosomatic Research, 31*(1), 63-71.
- Flor, H., Turk, C.D., & Rudy, T.E. (1989). Relationship of pain impact and significant other reinforcement of pain behaviors: the mediating role of gender, marital status and marital satisfaction. *Pain, 38*, 45-50.
- Geenen, R., & van Middendorp, H. (2006). The ostrich strategy towards affective issues in alexithymic patients with fibromyalgia. *Patient Education and Counseling, 60*, 97-99.
- Goldberg, L.R. (1992). The development of markers for the Big-Five factor structure. *Psychological assessment, 4*(1), 26-42.
- Goldenberg, D.I., Burckhardt, C., Crofford, L.J. (2004). Management of fibromyalgia syndrome. *Journal of American Medical Association, 292* (19), 2388-2395.
- Gowans, S.E., Dehueck, A., Voss, S., Richardson, M. (1999). A randomized control trial of exercise and education for individuals with fibromyalgia. *Arthritis Care Research, 12*, 120-128.
- Grewal, R. (2004). Multicollinearity and measurement error in structural equation models: Implications for theory testing. *Marketing Science, 23*(4), 519-529.
- Griffin, D.W., & Bartholomew, K. (1994). The metaphysics of measurement: The case of adult attachment. *Advances in Personal Relationships, 5*, 17-52.
- Guttman, H., & Laporte, L. (2002). Alexithymia, empathy, and psychological symptoms in a family context. *Comprehensive Psychiatry, 43*, 448-455.
- Hallberg, L. R-M., & Carlsson, S.G. (1998). Psychosocial vulnerability and maintaining forces related to fibromyalgia: In-depth interview with twenty-two female patients. *Scandinavian Journal of Caring Sciences, 12*, 95-103.
- Hauser, W., Bernardy, K., Uceyler, N., Sommer, C. (2009). Treatment of fibromyalgia syndrome with antidepressants: A meta-analysis. *Journal of the American Medical Association, 301*(2), 198-209.
- Hazan, C., & shaver, P.R. (1987). Romantic love conceptualized as and attachment process. *Journal of Personality and Social Psychology, 3*, 511-524.
- Hazan, C., & Shaver, P.R. (1994). Attachment as an organizational framework for research on close relationships. *Psychological Inquiry, 5*(1), 1-22.

- Helmes, E., McNeill, P.D., Holden, R.R., & Jackson, C. (2008). The construct of alexithymia: Associations with defense mechanisms. *Journal of Clinical Psychology, 64*(3), 318-331.
- Henriksson, C.M. (1995). Living with continuous muscular pain: Patient perspectives. Part I: Encounters and consequences. *Scandinavian Journal of Caring Sciences, 9*, 67-76.
- Humphreys, T.P., Wood, L. M., & Parker, J.D.A. (2009). Alexithymia and satisfaction in intimate relationships. *Personality and Individual Differences, 46*, 43-47.
- van Houdenove, B., Egle, U. T (2004). Fibromyalgia: A stress disorder? Piecing the biopsychosocial puzzle together. *Psychotherapy and psychosomatics, 73*(5), 267-275.
- International Association for the Study of Pain, Subcommittee on taxonomy. (1986). Classification of chronic pain: Descriptions of chronic pain syndromes and definitions of pain terms. *Pain, (suppl. 3)*, S1-S225.
- Johansen, A.B., & Cano, A. (2007). A preliminary investigation of affective interaction in chronic pain couples. *Pain, 132*, 586-595.
- Johnson, S.M (2004). *The Practice of Emotionally Focused Couple Therapy: Creating Connections*. New York: Brunner/Mazel.
- Joreskog, K.G. (1998). Interaction and nonlinear modeling: Issues and approaches. In R.E Schumacker & G.A Marcoulides (Eds): *Interaction and nonlinear effects in structural equation modeling* (239-250). Mahwah, NJ: Lawrence Erlbaum Associates Publishers.
- Kelley, P. (1998). Loss experienced in chronic pain and illness. In J Harvey (Ed). *Perspectives on loss: A sourcebook* (201-211). New York: Routledge.
- Kenny, D.A., Kashy, D.A., & Cook, W.L., & Simpson, J.A. (2006). *Dyadic data analysis*. New York: The Guilford Press.
- Kerns, R.d., Haythornthwaithe, J., Southwick, S, & Giller, E.L. (1990). The role of marital interaction in chronic pain and depressive symptom severity. *Journal of Psychosomatic Research, 34*, 401-408.
- Kiecolt-Glaser, J., Newton, T. (2001). Marriage and health: His and hers. *Psychological Bulletin, 127*, 472-503.
- Kleinman, A. (1988). *The illness narratives: Suffering, healing, and the human condition*. New York: Basic Books.

- Kline, R. (2004). *Principles and practice of structural equation modeling (Methodology in social science)*. New York: The Guilford Press.
- Kobak, R.R., & Hazan, C. (1991). Attachment in marriage: Effects of security and accuracy of working models. *Journal of Personality and Social Psychology*, *60*, 861-869.
- Kokkonen, P., Karvonen, J.T., Veijola, J., Laksy, K., Jokelainen, J. (2001). Prevalence and socio-demographic correlates of alexithymia in a population sample of young adults. *Comprehensive Psychiatry*, *42*(6), 471-476.
- Kool, M.B., Woertman, L., Prins, M.A., van Middendorp, H., & Geenen, R. (2006). Low relationship satisfaction and high partner involvement predict sexual problems of women with fibromyalgia. *Journal of Sex and Marital Therapy*, *32*, 409-423.
- Kossek, E., Ekholm, J., & Hansson, P. (1996). Sensory dysfunction in fibromyalgia patients with implications for pathogenic mechanisms. *Pain*, *68*, 375-383.
- Kossek, E., & Hanson, P. (1997). Modulatory influence on somatosensory perception from vibration and heterotopic noxious conditioning in fibromyalgia patients and healthy subjects. *Pain*, *70*, 41-51.
- Kowal, J., Johnson, S.m., & Lee, A. (2003). Chronic illness in couples: A case for emotionally focused therapy. *Journal of Marital and Family Therapy*, *29*(3), 299-310.
- Leonard, M.T., Cano, A., & Johansen, A.B (2006). Chronic pain in a couples context: A review and integration of theoretical models and empirical evidence. *The Journal of Pain*, *7*(6), 337-390.
- Luminet, O., Rime, B., Bagby, R.M., & Taylor, G.J. (2004). A multimodal investigation of emotional responding in alexithymia. *Cognition Emotion*, *18*, 741-766.
- Lumley, M.L., Beyer, J., & Radcliffe, A. (2008). Alexithymia and physical health problems: A critique of potential pathways and a research agenda. In J.J.M Vingerhoets, I Nyklicek, & J Denollet (Eds). *Emotion Regulation: Conceptual and Clinical Issues* (43-68). New York: Springer.
- Lussier, Y., Sabourin, S., & Turgeon, C. (1997). Coping strategies as moderators of the relationship between attachment and marital adjustment. *Journal of Social Personal Relationships*, *14*(6), 777-791.
- Madden, S., & Sim, J. (2006). Creating meaning in fibromyalgia syndrome. *Social Science & Medicine*, *63*, 2962-2973.

- Malinckrodt, B., King, J.L., Coble, H.M. (1998). Family dysfunction, alexithymia, and client attachment to therapist. *Journal of Counseling Psychology, 45*, 497-504.
- Malinckrodt, B., & Wei, M. (2005). Attachment, social competencies, social support, and psychological distress. *Journal of Counseling Psychology, 52*(3), 358-367.
- Masheb, R.M., Brondolo, E., & Kerns, R.d. (2002). A multidimensional, case-control study of women with self-identified chronic vulvar pain. *Pain Medicine, 3*(3), 253-259.
- McWilliams, I.A., Cox, B.J., & Enns, M.W. (2000). Impact of adult attachment styles on pain and disability associated with arthritis in a nationally representative sample. *Clinical Journal of Pain, 16*, 360-364.
- Mease, P. (2008). Recognizing fibromyalgia syndrome as a true disease entity. *Medscape*. Retrieved September 10, 2008 from <http://www.medscape.com/viewarticle/579696>.
- Mengshoel, A. M., Forseth, K. O., Haugen, M., Walle-Hansen, R., & Forre, O. (1995). Multidisciplinary approach to fibromyalgia: A pilot study. *Clinical Rheumatology, 14*, 165-170.
- Meredith, P., Ownsworth, T., & Strong, J. (2008). A review of the evidence linking adult attachment theory and chronic pain: Presenting a conceptual model. *Clinical Psychology Review, 28*, 407-429.
- Meredith, P.J., Strong, J., & Feeney, J.A. (2005). Evidence of a relationship between adult attachment variables and appraisals of chronic pain. *Pain Research and Management, 10*, 191-200.
- Meredith, P.J., Strong, J., & Feeney, J.A. (2007). Adult attachment variables predict depression before and after treatment in chronic pain. *European Journal of Pain, 11*, 164-170.
- Meyers, S.A., & Landsberger, S.A. (2002). Direct and indirect pathways between adult attachment style and marital satisfaction. *Personal Relationships, 9*, 159-172.
- van Middendorp, H., Lumley, M.A., Jacobs, J.W.G., van Doornen, L.J.P., Bijlsma, J.W.J., & Geenen, R. (2008). Emotions and emotional approach and avoidance strategies in fibromyalgia. *Journal of Psychosomatic Research, 64*, 159-167.
- Mikail, S.F., Henderson, P.R., & Tasca, G.A. (1994). An interpersonally based model of chronic pain: An application of attachment theory. *Clinical Psychology Review, 14*, 1-16.

- Mikulincer, M., Florian, V., & Tolmacz, R. (1990). Attachment styles and fear of personal death: A case study of affect regulation. *Journal of Personality and Social Psychology*, *58*, 273-280.
- Mikulincer, M., & Florian, V. (1998). The relationship between adult attachment styles and emotional and cognitive reactions to stressful events. In J.A. Simpson & W.s Rholes (Eds). *Attachment theory and close relationships*(143-165). New York: The Guilford Press.
- Mikulincer, M., & Shaver, P.R. (2008). Adult attachment and affect regulation. In J. Cassidy & P.R. Shaver (Eds). *Handbook of attachment: Theory, Research, and Clinical Applications*(503-531). New York: The Guilford Press.
- Montebarocci, O., Codispoti, M., Baldaro, B., & Rossi, N. (2004). Adult attachment style and alexithymia. *Personality and Individual Differences*, *36*, 499-507.
- Moorman, P.P., Bermond, B., Vorst, H.C.M., Bloemendaal, A.F.T., Teijn, S.M., & Rood, L. (2008). New avenues in alexithymia research: The creation of alexithymia types. In J.J.M Vingerhoets, I Nyklicek, & J Denollet (Eds). *Emotion Regulation: Conceptual and Clinical Issues* (27-42). New York: Springer.
- Murray, T.L., Murray, C.E., & Daniels, M.H. (2007). Stress and family relationship functioning as indicators of the severity of fibromyalgia symptoms: A regression analysis. *Stress and Health*, *23*, 3-8.
- Nemiah, J.C., Freyberger, H., & Sifneos, P.E. (1976). Alexithymia: A view of the psychosomatic process. In O.W Hill (Ed). *Modern trends in psychosomatic medicine* (vol. 3, 430-439). London: Butterworths.
- Newton-John, T.R., de C Williams, A.C. (2006). Chronic pain couples: Perceived marital interactions and pain behaviors. *Pain*, *123*, 53-63.
- Okifuji, A., & Turk, D.C. (1999). Fibromyalgia: Search for mechanisms and effective treatments. In r. J. Gatchel & D. C Turk (Eds). *Psychosocial factors in pain* (227-246). New York: The Guilford Press.
- Pearce, S., Creed, P., & Cramond, T. (2001). Attachment style and chronic pain syndrome. *Australian Pain Society Newsletter*, *2-4*.
- Pedrosa Gil, F., Weigl, M., Wessels, T., Irnich, D., Baumuller, E., & Winkelmann, A. (2008). Parental bonding and alexithymia in adults with fibromyalgia. *Psychosomatics*, *49*, 115-122.
- Picardi, A., Toni, A., & Caroppo, E. (2005). Stability of alexithymia and its relationships with the 'Big Five' factors, temperament, character, and attachment style. *Psychotherapy and Psychosomatics*, *74*, 371-378.

- Posse, M., Hallstrom, T., & Backenroth-Ohsako, G. (2002). Alexithymia, social support, psycho-social stress, and mental health in a female population. *Nordic Journal of Psychiatry*, *56*, 329-334.
- Preece, J.C., & Sandberg, J.G. (2005). Family resilience and the management of fibromyalgia: Implications for family therapists. *Contemporary Family Therapy*, *27*(4), 559-576
- Raphael, K. G. (2006). Fibromyalgia syndrome: A role for sexual abuse and other traumatic events. *Primary Psychiatry*, *13*(9), 61-65.
- Rao, S. G., Gendreau, J. F., & Kranzler, J.D. (2007). Understanding the fibromyalgia syndrome. *Psychopharmacology Bulletin*, *40*(4), 24-56.
- Reich, J.W., & Olmsted, M. (2007). Partner's social control effects on relationship satisfaction in fibromyalgia patients: Illness uncertainty and bodily pain as moderators. *Journal of Social and Clinical Psychology*, *26*(5), 623-639.
- Romano, J.M., Turner, J.A., & Clancy, S.L. (39). Sex differences in the relationship of pain and patient dysfunction to spouse adjustment. *Pain*, *39*(3), 289-295.
- Romano, J.M., Turner, J.A., & Jensen, M.P. (1997). The family environment in chronic pain patients: Comparison to controls and relationship to patient functioning. *Journal of Clinical Psychology in Medical Settings*, *4*(4), 383-395.
- Rossy, L. A., Buckelew, S. P., Dorr, N., Haglund, K. J., Thayer, J.F., McIntosh, M. J., Hewett, J. E., & HJohnson, J. C. (1999). A meta-analysis of fibromyalgia treatment interventions. *Annals of Behavioral Medicine*, *21*(2), 180-191.
- Saarjivari, S., Rykotoski, U., Karppi, S. Marital satisfaction and distress in chronic low-back pain patients and their spouses. *Clinical Journal of Pain*, *6*, 148-152.
- Schlesinger, L. (1996). Chronic pain, intimacy and sexuality: A qualitative study of women who live with pain. *The Journal of Sex Research*, *33*, 249-256.
- Schmidt, S. (2005). Attachment and coping. In A.V Lee (Ed), *Psychology of Coping*. Nova Science Publishers.
- Schmidt, S., Nachtigall, C., Wuetrich-MArtone, O, & Strauss, B (2002). Attachment and coping with chronic disease. *Journal of Psychosomatic Research*, *53*(3), 763-773.
- Schwartz, L., & Ehde, D.M. (2000). Couples and chronic pain. In K.B Schmaling & T. G Sher (Eds), *The psychology of couples and illness: Theory, research, & practice*. Washington, DC: American Psychological Association.

- Schwartz, L., Slater, M.A., & Birchler, G.R. (1994). Interpersonal stress and pain behaviors in patients with chronic pain. *Journal of Consulting and Clinical Psychology, 62*(4), 861-864.
- Seng, J.S., Clark, M. K., McCarthy, A. M., Ronis, D. L. (2006). PTSD and physical comorbidity among women receiving Medicaid: Results from service-use data. *Journal of Traumatic Stress, 19*(1), 45-46.
- Shaver, P.R., Hazan, C. (1988). A biased overview of the study of love. *Journal of Social and Personal Relationships, 5*, 473-501.
- Shaver, P.R., Hazan, C., & Bradshaw, D. (1988). Love as attachment: The integration of three behavioral systems. In R.J. Sternberg & M. Barnes (Eds). *The Psychology of Love*. New Haven, CT: Yale University Press
- Sifneos, P.E. (1972). The prevalence of 'alexithymic' characteristics in psychosomatic patients. *Psychotherapy & Psychosomatics, 22*, 255-262.
- Smythe, H.A., & Moldofsky, H. (1977-1978). Two contributions to understanding of the "fibrositis" syndrome. *Bulletin of the Rheumatic Diseases, 28*(1), 928-931.
- Spitzer, C., Siebel-Jurges, U., Barnow, S., Grabe, H.J., & Freyberger, H.J. (2005). Alexithymia and interpersonal problems. *Psychotherapy and Psychosomatics, 74*, 240-246.
- Steinberg, D.P. (2007). The experience of relationships: Twelve people with fibromyalgia. *Dissertation Abstracts International; Section B; The Sciences and Engineering; vol. 68 (3-A)*, 1163.
- Stiell, K., Naaman, S.C., & Lee, A (2007). Couple and chronic illness: An attachment perspective and emotionally focused therapy interventions. *Journal of Systemic Therapies, 26*(4), 59-74.
- Stone, A.A., Bachrach, C.A., Jobe, J.B., Kurtzman, H.S., & Cain, V.S. (1999). *The science of self-report: Implications for research and practice*. Psychology Press.
- Stuifbergen, A.K., Philips, L., Voelmeck, W., & Browder, R. (2006). Illness perceptions and related outcomes among women with fibromyalgia syndrome. *Women's health issues, 16*, 353-360.
- Sullivan, M.J.L., Trip, D.a., Santor, D. (2000). Gender differences in pain and pain behavior: The role of catastrophizing. *Cognitive Theory and Research, 24*(1), 121-134.

- Sullivan, M.J.L., Thorn, B., Haythornthwaite, J.A., Keefe, F., Martin, M., Bradley, L.A., & Lefebvre, J.C. (2001). Theoretical perspectives on the relationship between catastrophizing and pain. *Clinical Journal of Pain, 17*(1), 52-64.
- Tacon, A (2003). Attachment experiences in women with breast cancer. *Family and Community Health, 26*, 147-156.
- Taylor, G.J (1984). Alexithymia: Concept, measurement, and implications for treatment. *American Journal of Psychiatry, 141*, 725-732.
- Taylor, G.J., Bagby, R.M., & Parker, J.d.A. (1992). The revised Toronto Alexithymia Scale: Some reliability, validity and normative data. *Psychotherapy & Psychosomatics, 57*, 34-41.
- Taylor, M.L., Trotter, D. R., & Csuka, M.E. (1995). The prevalence of sexual abuse in women with fibromyalgia. *Arthritis and Rheumatism, 38*(2), 229-234.
- Taylor, R.E., Mann, A.H., White, N.J., & Goldberg, D.P. (2000). Attachment style in patients with unexplained physical complaints. *Psychological Medicine, 30*, 931-941.
- Todarello, O., Casamassima, A., Marinaccio, M., La Pesa, M.W., Caradonna, L., Valentino, L., et al. (1994). Alexithymia, immunity and cervical intraepithelial neoplasia: A pilot study. *Psychotherapy and Psychosomatics, 61*, 199-204.
- Todarello, O., Casamassima, A., Daniele, S., Marinaccio, M., Fanciullo, F., Valentino, L., et al. (1997). Alexithymia, immunity and cervical intraepithelial neoplasia: replication. *Psychotherapy and Psychosomatics, 66*, 208-213.
- Troisi, A., D'Argenio, A., Peracchi, F., & Petti P. (2001). Insecure attachment and alexithymia in young men with mood symptoms. *Journal of Nervous and Mental Disease, 189*(5), 311-316.
- Turan, B., Osar, Z., Turan J.M., Ilkova, H., & Damci, T. (2003). Dismissing attachment and outcome in diabetes: The mediating role of coping. *Journal of Social and Clinical Psychology, 22*(6), 607-626.
- Turk, D.C., Kerns, R.D. (1985). The family in health and illness. In .C Turk & R.d Kerns (Eds), *Health, Illness, and Families: A life Span Perspective* (1-22). New York: Wiley
- Turk, D.C., Meichenbaum, D., Genest, M. (1983). *Pain and behavioral medicine: A cognitive-behavioral perspective*. New York: The Guilford Press

- Turk, D. C., Okifuji, A., Sinclair, J. D., & Starz, T. W. (1996). Pain, disability, and physical functioning in subgroups of patients with fibromyalgia. *Journal of Rheumatology*, *23*, 1255-1262.
- Turk, D. C., Okifuji, A., Sinclair, J. D., & Starz, T. W. (1998). Differential responses by psychosocial subgroups of fibromyalgia syndrome patients to an interdisciplinary treatment. *Arthritis Care and Research*, *11*, 397-404.
- Turk, D.C. (2002). Suffering and dysfunction in fibromyalgia syndrome. *Journal of Musculoskeletal Pain*, *10*(1/2), 85-96.
- Ungureanu, I, & Sandberg, J.G. (2010). "Broken Together": Spirituality and religion as coping strategies for couples dealing with death of a child: A literature review with clinical implications. *Contemporary Family Therapy*, *32*(3), 302-319.
- Vanheule, S., Desmet, M., Meganck, R., & Bogaerts, S. (2007). Alexithymia and interpersonal problems. *Journal of Clinical Psychology*, *63*, 10-117.
- Vanheule, S., Desmet, M., Rosseel, Y., rhaege, P., Meganck., R. (2007). Relationship patterns in alexithymia: A study using the Core Conflictual Relationship Theme (CCRT) method. *Psychopathology*, *40*, 14-21.
- Vanheule, S., Vanderbergen, J., Desmet, M., Rosseel, Y., & Inslegheers, R. (2007) Alexithymia and core conflictual relationship themes: A study in a chronically fatigued population. *International Journal of Psychiatry in Medicine*, *37*(1), 87-98.
- de Voogd, J. N., Knipping, A. A., de Blecourt, A. C. E., & van Rijswijk, M. H. (1993). Treatment of fibromyalgia syndrome with psychomotor therapy and marital counseling. *Journal of Musculoskeletal Pain*, *1*(3-4), 273-281.
- Wearden, A. J, Cook, L., & Vaughan-Jones, J. (2002). Adult attachment, alexithymia, symptom reporting, and health-related coping. *Journal of Psychosomatic Research*, *55*, 341-347.
- Wearden, A.J., Lamberton, N., Crook, N., & Walsh, V. (2004). Adult attachment, alexithymia, and symptom reporting: An extension to the four category model of attachment. *Journal of Psychosomatic Research*, *58*, 279-288.
- White, K.P., Specheley, M., Harth, M., & Ostbye, T (1999). Comparing self-reported function and work disability in 100 community cases of fibromyalgia syndrome versus controls in London, Ontario: The London Fibromyalgia Epidemiology Study. *Arthritis in Rheumatology*, *42*(1), 76-83.

- Williams, D.A. (2003). Psychological and behavioral therapies in fibromyalgia and related syndromes. *Best Practices in Research and Clinical Rheumatology*, 17, 649-665.
- Williamson, G.M., Walters, A.S., Schaffer, D.R. (2002). Caregiver models of self and others, coping and depression: Predictors of depression in children with chronic pain. *Health Psychology*, 21(4), 405-410.
- Wolfe, F., Smythe, J.A., Yunus, M.B., Bennett, R.M., Bombardier, C., Goldenberg, D.J., Tugwell, P., Campbell, S.M., Abeles, M., Clark, P., Fam, A. G., Farber, S. J., Fiechtner, J. J., Franklin, C.M., Gatter, R.A., Hamaty, D., Lessard, J., Lichtbroun, A. S., Masi, A.T., McCain, G.A., Reynolds, W.J., Romano, T.J., Russel. I. J., & Sheon, R. P (1990). The American College of Rheumatology 1990 criteria for the classification of fibromyalgia: Report of the multicenter criteria committee. *Arthritis and Rheumatism*, 36, 160-172.
- Zackheim, L. (2007). Alexithymia: The expanding realm of research. *Journal of Psychosomatic Research*, 63, 345-347.
- Zautra, A.J., Hamilton, N.a., & Burke, H.M. (1999). Comparison of stress responses in women with two types of chronic pain: Fibromyalgia and osteoarthritis. *Cognitive Therapy and Research*, 23(2), 209-230.

ILEANA UNGUREANU

Syracuse University, Syracuse, New York
Adler School of Professional Psychology, Chicago, Illinois
E: iungureanu@adler.edu
T: 312/662-4314

EDUCATION

Syracuse University, Syracuse, NY, USA
M.A. Marriage & Family Therapy, December, 2006
MFT PhD candidate Fall 2006- present

“Victor Babes” University of Medicine and Pharmacy, Timisoara, Romania.

- MD, September, 1995
- Residency- Family Medicine, 1996-2000.

WORK

EXPERIENCE

Clinical experience

- Chicago Center for Family Health, University of Chicago, Chicago
Doctoral Fellow 2009-present
- Goldberg Couple & Family Therapy Center, Syracuse University
Marriage and Family Therapist 2005-2008
- Center for Children’s Cancer and Blood Disorders, SUNY Upstate Medical
University, University Hospital
Marriage and Family Therapist 2005- 2007
- Office of Student Services, College of Human Ecology, Syracuse University.
Academic Counselor 2005-2009
- Areopagus Regional Center for Social Integration and Human Development,
Timisoara, Romania.
Group Facilitator 2000-2004
- Chosen Foundation Romania, Timisoara.
Family counselor, group facilitator. 2002-2004
- Oncology Department of Children’s Hospital “Louis Turcanu”, Timisoara, Romania
Family counselor
- Cabinet medical “Dr. Radu”, Timisoara, Romania.
Family Physician. 2000-2004

Teaching experience:

- *Life cycle and diversity issues in Marriage and Family Therapy*, Adler School of Professional Psychology, Fall 2011, Chicago
- *Effective Marital and Family Therapy Models*, Adler School of Professional Psychology, Spring 2010, Chicago.
- *Basic skills in psychotherapy*, Adjunct Faculty, Adler School of Professional Psychology, Fall 2010, Fall 2011, Chicago.
- *Life Span Development*, Adjunct Faculty, Adler School of Professional Psychology, Fall 2010, Chicago.
- *Overview of Marriage and Family Therapy Models – blended version*. Adjunct Faculty, Adler School of Professional Psychology, Summer 2010, Fall 2010, Spring 2011, Chicago
- *Solution- Focused Family Therapy*. Postgraduate course taught on-line, Areopagus Institute of Family Therapy and Systemic Practice, Timisoara, Romania, July 2010.
- *A family model in understanding psychosocial issues related to genetic counseling*. Guest lecturer, Genetic Counseling Program, Feinberg School of Medicine, Northwestern University, April 2005, Chicago.
- *Structural Family Therapy*. Postgraduate course taught at the Areopagus Institute of Family Therapy and Systemic Practice, June 2009, Timisoara, Romania.
- *Loss issues in the family system*. Postgraduate course taught at the Areopagus Institute of Family Therapy and Systemic Practice, July 2008, Timisoara, Romania.
- *Medical Family Therapy*. Postgraduate seminar taught at the Areopagus Institute of Family Therapy and Systemic Practice, July 2008, Timisoara, Romania.
- *Assessment in Family Therapy*. Master level course co-taught at Syracuse University, May-June 2008, Syracuse, NY.

Research experience:

- *Fibromyalgia Syndrome: The Relationship Between Alexithymia and Adult Attachment Style on Couple Relationship*. Quantitative research. Syracuse University, 2011.
- *Caring for dying children: costs and rewards*. Qualitative research. Syracuse University, 2006.
- *The impact of childhood and adolescent cancer on the family*. Qualitative research. University of Medicine and Pharmacy, Timisoara, Romania, 2000.
- *Carbamazepine in the long-term treatment of mood disorders*. Quantitative research. Graduate Dissertation, University of Medicine and Pharmacy, Timisoara, Romania, 1995.

Manuscripts published.

- Ungureanu, I., & Sandberg, J.G (2010). "Broken Together" - Spirituality and religion as coping strategies for couples dealing with the death of a child: A literature review with clinical implications. *Contemporary Family Therapy*, 32 (3), 302-319.
- Ungureanu, I., & Sandberg, J.G. (2008). Caring for dying children and their families: MFTs working at the gates of the Elysian Fields. *Contemporary Family Therapy*, 30(2), 75-91
- Ungureanu, I (2008). The transgenerational transmission of the communist trauma: The Romanian experience. *Terapia sistematica/Systemic Therapies*, 1, 5-10.

Academic presentations.

- Ungureanu, I., & Lister, Z. Developing a psychosocial integrative component in an existing diabetes treatment program: Reflections and recommendations for interdisciplinary collaboration. 12th Collaborative Family Healthcare Association Annual Conference. Louisville, Kentucky, October, 2010.
- Ungureanu, I., & Sandberg, J.G. *Losing a child: An EFT perspective on couples' experience*. 67th American Association for Marriage and Family Therapy Annual Conference. Sacramento, California, October, 2009.
- Rogobete, I., & Ungureanu, I. Transgenerational transmission of political trauma in families living under repressive regimes: A comparative study between apartheid and totalitarian communism, The 15th Congress of Psychology, Cape Town, South-Africa, September, 2009.

- Ungureanu, I., & Sandberg, J.G. *Caring for dying children: The MFT experience*. 65th American Association for Marriage and Family Therapy Annual Conference. Long Beach, California, October, 2007.
- Ungureanu, I., & Sandberg, J.G. *Caring for dying children: costs and rewards*. 2nd International Conference of Family Psychotherapy and Systemic Practice. Timisoara, Romania, November 2006.
- McKay, R., Ungureanu, I., & Kortz, M. *Care for the caregiver*. Pediatric Palliative Care workshop. SUNY Upstate Medical University, February 2006.
- Ungureanu, I. *Psychological defense mechanisms in the families with a child with cancer*. 6th Romanian-Hungarian Scientific Reunion in Oncopediatrics. Buzias, Romania, May 2003.
- Ungureanu I. *Family- "First-hand" community resource for medical practice*. 13th National Conference of the Christian Medical Association. Paltinis, Romania, September, 2002.
- Ungureanu, I. *Cancer- a challenge for the family, a challenge for Family Therapy*. First National Conference in Family Therapy. Timisoara, Romania, June 2002.
- Ungureanu, I. *A systemic view on psychosomatic pathology*. 3th National Conference in Psychotherapy. Gataia, Romania, September 2001.

Awards

Irving B. Harris Fellowship, Chicago Center for Family Health, January 2010

FULBRIGHT scholarship, October 2003.

Graduate Assistantships, Syracuse University, 2005- 2008

Professional Affiliation

American Association for Marriage and Family Therapy, student member, 2004 – present

International Family Therapy Association, student member, 2009 – present

Collaborative Family HealthCare Association, 2010-present.

Romanian Family Therapy and Systemic Practice Association, founding member, 2000 – present

Special interests

Couples therapy, Medical Family Therapy, loss, trauma, spirituality.

Languages

Romanian, English, French, Serbian.