

South Dakota State University
**Open PRAIRIE: Open Public Research Access Institutional
Repository and Information Exchange**

Electronic Theses and Dissertations

2018

Compaction Testing of Granular Material

Jason Jerome Weber
South Dakota State University

Follow this and additional works at: <https://openprairie.sdstate.edu/etd>

 Part of the [Civil Engineering Commons](#), and the [Transportation Engineering Commons](#)

Recommended Citation

Weber, Jason Jerome, "Compaction Testing of Granular Material" (2018). *Electronic Theses and Dissertations*. 2488.
<https://openprairie.sdstate.edu/etd/2488>

This Thesis - Open Access is brought to you for free and open access by Open PRAIRIE: Open Public Research Access Institutional Repository and Information Exchange. It has been accepted for inclusion in Electronic Theses and Dissertations by an authorized administrator of Open PRAIRIE: Open Public Research Access Institutional Repository and Information Exchange. For more information, please contact michael.biondo@sdstate.edu.

COMPACTION TESTING OF GRANULAR MATERIAL

BY

JASON JEROME WEBER

A thesis submitted in partial fulfillment of the requirements of the

Master of Science

Major in Civil Engineering

South Dakota State University

2018

COMPACTION TESTING OF GRANULAR MATERIAL

JASON JEROME WEBER

This thesis is approved as a creditable and independent investigation by a candidate for the Master of Science degree and is acceptable for meeting the thesis requirements for this degree. Acceptance of this thesis does not imply that the conclusions reached by the candidate are the conclusions of the Civil Engineering department.

Allen L. Jones, Ph.D. ~~U~~P.E. Date
 Thesis Advisor
 Civil & Environmental Engineering Department

Nadim I. Wehbe, Ph.D, P.E. Date
 Department Head
 Civil & Environmental Engineering Department

Dean, ~~U~~ Graduate School Date

ACKNOWLEDGEMENTS

Funding for this study was provided by the South Dakota Department of Transportation (SDDOT). The support of the SDDOT is gratefully acknowledged. Dr. Allen Jones and Dr. Nadim Wehbe are gratefully acknowledged for their guidance and support. Also acknowledged is the SDDOT technical panel for their feedback throughout this process. My family's support is always appreciated.

TABLE OF CONTENTS

ABBREVIATIONS	viii
LIST OF FIGURES	ix
LIST OF TABLES	xii
ABSTRACT.....	xvi
1.0 INTRODUCTION	1
1.1 PROBLEM DESCRIPTION.....	1
1.2 RESEARCH OBJECTIVES	3
1.3 TASK DESCRIPTIONS.....	5
2.0 LITERATURE REVIEW.....	9
2.1 FUNDAMENTALS.....	9
2.1.1 <i>Granular Materials</i>	9
2.1.2 <i>Semi Draining and Free Draining Granular Materials</i>	13
2.2 EFFECTIVE LABORATORY COMPACTION TEST METHODS	16
2.2.1 <i>Impact Compaction Methods</i>	16
2.2.2 <i>Vibratory Compaction Methods</i>	21
2.3 TRADITIONAL IN-SITU COMPACTION TEST METHODS	22
2.3.1 <i>Families of Compaction Curves</i>	22
2.3.2 <i>In-Situ Compaction Verification Using Traditional Sand-Cone Test Method</i>	31

2.3.3	<i>In-Situ Compaction Verification Using Traditional Rubber-Balloon Test Method</i>	33
2.3.4	<i>Nuclear Density Gauge Review</i>	35
2.4	ALTERNATIVE DENSITY-BASED MEASUREMENT TEST METHODS	37
2.4.1	<i>Moisture Density Indicator</i>	37
2.4.2	<i>Electric Density Gauge</i>	39
2.4.3	<i>Soil Density Gauge</i>	39
2.5	STIFFNESS / STRENGTH MEASUREMENT TESTS METHODS	40
2.5.1	<i>Clegg Hammer</i>	41
2.5.2	<i>GeoGauge</i>	41
2.5.3	<i>Light Weight Deflectometer</i>	42
2.5.4	<i>Dynamic Cone Penetrometer</i>	42
2.6	DEVICE COST	49
2.7	INTELLIGENT COMPACTION	49
2.8	CURRENT SDDOT PRACTICES	50
2.8.1	<i>Materials Encountered and Gradation Requirements</i>	51
2.8.2	<i>Methods of Base Course and Subbase Compaction Quality Control</i>	52
2.8.3	<i>Methods of Recycled and Salvaged Compaction Quality Control</i>	54
3.0	DATA COLLECTION AND ANALYSIS	56
3.1	ANALYSIS GOALS	56
3.2	DATA COLLECTION AND CONDITIONING	57
3.3	LINES OF OPTIMUMS COMPARISON	68
3.4	DETERMINING ADEQUACY OF FAMILIES OF CURVES	71

3.5	SUMMARY OF SURVEY RESULTS	84
4.0	DISCUSSION OF ALTERNATIVES	87
4.1	ALTERNATIVES COMPARISON.....	87
4.2	DISCUSSION OF SCORING.....	90
4.2.1	<i>Current SDDOT (Density-Based) Devices</i>	90
4.2.2	<i>Density-Based Devices</i>	91
4.2.3	<i>Stiffness / Strength Based Devices</i>	91
5.0	FINDINGS AND CONCLUSIONS	93
5.1	LITERATURE FINDINGS	93
5.2	SURVEY FINDINGS	94
5.3	DATA ANALYSIS FINDINGS.....	95
5.4	RESEARCH CONCLUSIONS	95
6.0	RECOMMENDATIONS AND IMPLEMENTATION.....	98
6.1	THE SDDOT BASE AND SUBBASE MOISTURE DENSITY CURVES	98
6.2	THE DYNAMIC CONE PENETROMETER.....	108
6.3	IMPLEMENTATION PLAN.....	108
7.0	RESEARCH BENEFITS	111
	APPENDIX A: PREPARED PROCEDURES, METHODS, AND SUPPLEMENTAL SPECIFICATIONS	113
	149
	APPENDIX B: DATA ANALYSIS	150

APPENDIX C: SURVEYS 243

8.0 REFERENCES..... 249

ABBREVIATIONS

AASHTO	American Association of State Highway and Transportation Officials
ASTM	American Society for Testing Materials
CBR	California Bearing Ratio
CH	Clegg Hammer
CIV	Clegg Impact Value
DCP	Dynamic Cone Penetrometer
DOT	Department of Transportation
DPI	DCP Penetration Index
EDG	Electric Density Gauge
EIS	Electromagnetic Impedance Spectroscopy
ERDC	Engineering Research and Development Center
FDR	Full Depth Reclamation
GPS	Global Positioning System
HMA	Hot Mix Asphalt
LWD	Light Weight Deflectometer
MDI	Moisture Density Indicator
NCHRP	National Cooperative Highway Research Program
NDG	Nuclear Density Gauge
NRC	Nuclear Regulatory Commission
ODOT	Ohio Department of Transportation
OMC	Optimum Moisture Content
PCC	Portland Concrete Cement
pcf	Pounds per Cubic Foot
PDA	Personal Digital Assistant
PI	Primary Investigator
PIV	Penetration Index Value
RAP	Reclaimed Asphalt Pavement
RTK	Real-Time Kinematic
SDDOT	South Dakota Department of Transportation
SDG	Soil Density Gauge
TDR	Time Domain Reflectometry

LIST OF FIGURES

FIGURE 1: AASHTO M 145 GROUP INDEX CHART (AASHTO, 2015A).....	12
FIGURE 2: THE MOISTURE DENSITY RELATIONSHIP FOR FREE DRAINING GRANULAR SOIL (DRNEVICH, 2007).	15
FIGURE 3: THE PROCESS OF SHEEP FOOT ROLLER “WALK OUT”	17
FIGURE 4: MOISTURE DENSITY RELATIONSHIP COHESIVE FINE GRAIN SOILS (DRNEVICH, 2007).	18
FIGURE 5: PARAMETER COMPARISON OF STANDARD VERSES MODIFIED LABORATORY COMPACTION TESTS (FELT, 1958).	20
FIGURE 6: TYPICAL EMBANKMENT CONTROL CURVES, SET A (JOSLIN, 1958).....	24
FIGURE 7: OHIO HIGHWAY DEPARTMENT’S TYPICAL MOISTURE DENSITY CURVES, SET C, MAY 1949 (JOSLIN, 1958).	26
FIGURE 8: TYPICAL CURVE CIRCULAR SLIDE RULE (JOSLIN, 1958).	27
FIGURE 9: OHIO HIGHWAYS DEPARTMENT’S TYPICAL MOISTURE DENSITY CURVES, SET C WITH INTERPOLATED CURVES (SDDOT, 2015A)	29
FIGURE 10: IN-SITU SAND CONE DENSITY TEST APPARATUS (LIU AND EVETT, 2000).	32
FIGURE 11: SCHEMATIC DRAWING OF CALIBRATED VESSEL INDICATING PRINCIPLE (LIU AND EVETT, 2000).	34
FIGURE 12: THE NDG OPERATION IN BOTH BACKSCATTER AND DIRECT TRANSMISSION (NAZZAL, 2014).	36
FIGURE 13: PROBE PATTERN FOR THE MDI (NAZZAL, 2014).	38
FIGURE 14: DCP SCHEMATIC.	45
FIGURE 15: PLOTTED POINTS USED IN THE ANALYSIS.	62

FIGURE 16: OBSERVED SKEWED CURVE PHENOMENON.	64
FIGURE 17: LINE OF OPTIMUMS FOR NEW FAMILY OF COMPACTION CURVES (RED LINE).67	
FIGURE 18: LINES OF OPTIMUMS USED IN COMPARISON ANALYSIS.....	69
FIGURE 19: DRY UNIT WEIGHT DISTRIBUTION	72
FIGURE 20: OMC DISTRIBUTION	73
FIGURE 21: FITTED REGRESSION LINES FOR GRANULAR MOISTURE DENSITY RELATIONS.	74
FIGURE 22: RESIDUAL PLOT FOR THE LINEAR REGRESSION MODEL.....	75
FIGURE 23: RESIDUAL PLOT FOR THE THIRD DEGREE POLYNOMIAL MODEL.....	76
FIGURE 24: RESIDUAL PLOT FOR THE EXPONENTIAL MODEL.	76
FIGURE 25: STANDARDIZED RESIDUAL PLOT FOR THE LINEAR MODEL.....	76
FIGURE 26: STANDARDIZED RESIDUAL PLOT FOR THE THIRD-DEGREE POLYNOMIAL MODEL.	77
FIGURE 27: STANDARDIZED RESIDUAL PLOT FOR THE EXPONENTIAL MODEL.	77
FIGURE 28: PREDICTION INTERVAL FOR SOUTH DAKOTA GRANULAR SUBBASE AND BASE COURSE MATERIALS.	81
FIGURE 29: LINE OF OPTIMUMS PLOTTED WITHIN THE 95 PERCENT PREDICTION INTERVAL.....	83
FIGURE 30: THE SDDOT BASE AND SUBBASE MOISTURE DENSITY CURVES.	102
FIGURE 31: LINES OF OPTIMUM COMPARISON PLOTTED WITHIN PREDICTION INTERVAL.	103
FIGURE 32: THE PLOTTED EXAMPLE USING THE SDDOT MOISTURE DENSITY CURVES.	107

FIGURE 33: DOT-3 WORKSHEET (SIEVE ANALYSIS).	150
FIGURE 34: DOT-28 WORKSHEET (TEST STRIP).....	151
FIGURE 35: DOT-40 WORKSHEET (FOUR-POINT LABORATORY COMPACTION TEST)...	152
FIGURE 36: DOT-41 WORKSHEET (FIELD DENSITY TEST).....	153

LIST OF TABLES

TABLE 1: AASHTO CLASSIFICATION OF SOIL-AGGREGATE MIXTURES FOR GRANULAR MATERIALS.	11
TABLE 2: TABLE OF TARGET PIV AND SEATING REQUIREMENTS.....	48
TABLE 3: COST ESTIMATES FOR DEVICES SUMMARIZED.	49
TABLE 4: SDDOT SPECIFIC REQUIREMENTS FOR AGGREGATE ACCEPTANCE (SDDOT, 2015A).....	52
TABLE 5: DEFINED SDDOT DATA FORMS.....	59
TABLE 6: CURVE COEFFICIENTS.....	65
TABLE 7: SUMMARY OF NEW FAMILY OF COMPACTION CURVES.....	66
TABLE 8: SAMPLES USED FOR LINES OF OPTIMUMS COMPARISON.....	71
TABLE 9: T-TEST STATISTICS.....	71
TABLE 10: ADDITIONAL REGRESSION MODEL STATISTICS.	79
TABLE 11: SURVEY RECIPIENTS.	84
TABLE 12: SURVEY RESPONSE INFORMATION OF INTEREST.	86
TABLE 13: DECISION CRITERIA.	88
TABLE 14: CRITERIA SCORING SCHEME.....	89
TABLE 15: ESTIMATED IMPLEMENTATION COSTS.	97
TABLE 16: DATA FIELDS FOR DOT-3 WORKSHEET (SIEVE ANALYSIS).....	154
TABLE 17: DATA FIELDS FOR DOT-28 WORKSHEET (TEST STRIP).	158
TABLE 18: THE DATA FIELDS FOR DOT-40 WORKSHEET (FOUR-POINT LABORATORY COMPACTION TEST).....	161
TABLE 19: THE DATA FIELDS FOR DOT-41 WORKSHEETS (FIELD DENSITY TEST).	163

TABLE 20: DOT-40 POINTS USED FOR COMPACTION CURVES WITH A MAXIMUM DRY UNIT WEIGHT BELOW 118 PCF.....	166
TABLE 21: DOT- 40 POINTS USED FOR COMPACTION CURVES WITH A MAXIMUM DRY UNIT WEIGHT BETWEEN 118 PCF TO 120 PCF.	166
TABLE 22: DOT-40 POINTS USED FOR COMPACTION CURVES WITH A MAXIMUM DRY UNIT WEIGHT BETWEEN 120 PCF TO 122 PCF.....	169
TABLE 23: DOT-40 POINTS USED FOR COMPACTION CURVES WITH A MAXIMUM DRY UNIT WEIGHT BETWEEN 122 PCF TO 124 PCF.....	171
TABLE 24: DOT-40 POINTS USED FOR CURVES WITH A MAXIMUM DRY UNIT WEIGHT BETWEEN 124 PCF TO 126 PCF.....	173
TABLE 25: DOT-40 POINTS USED FOR COMPACTION CURVES WITH A MAXIMUM DRY UNIT WEIGHT BETWEEN 126 PCF TO 128 PCF.....	175
TABLE 26: DOT-40 POINTS USED FOR COMPACTION CURVES WITH A MAXIMUM DRY UNIT WEIGHT BETWEEN 128 PCF TO 130 PCF.....	177
TABLE 27: DOT-40 POINTS USED FOR COMPACTION CURVES WITH A MAXIMUM DRY UNIT WEIGHT BETWEEN 130 PCF TO 132 PCF.....	182
TABLE 28: DOT-40 POINTS USED FOR COMPACTION CURVES WITH A MAXIMUM DRY UNIT WEIGHT BETWEEN 132 PCF TO 134 PCF.....	191
TABLE 29: DOT-40 POINTS USED FOR COMPACTION CURVES WITH A MAXIMUM DRY UNIT WEIGHT BETWEEN 134 PCF TO 136 PCF.....	201
TABLE 30: DOT-40 POINTS USED FOR COMPACTION CURVES WITH A MAXIMUM DRY UNIT WEIGHT BETWEEN 136 PCF TO 138 PCF.....	210

TABLE 31: DOT-40 POINTS USED FOR COMPACTION CURVES WITH A MAXIMUM DRY UNIT WEIGHT BETWEEN 138 PCF TO 140 PCF.....	217
TABLE 32: DOT-40 POINTS USED FOR COMPACTION CURVES WITH A MAXIMUM DRY UNIT WEIGHT BETWEEN 140 PCF TO 142 PCF.....	221
TABLE 33: DOT-40 POINTS USED FOR COMPACTION CURVES WITH A MAXIMUM DRY UNIT WEIGHT BETWEEN 142 PCF TO 144 PCF.....	224
TABLE 34: OMC AND MAXIMUM DRY UNIT WEIGHT DETERMINATIONS LESS THAN 118 PCF.....	226
TABLE 35: OMC AND MAXIMUM DRY UNIT WEIGHT DETERMINATIONS BETWEEN 118 PCF AND 120 PCF.	227
TABLE 36: OMC AND MAXIMUM DRY UNIT WEIGHT DETERMINATIONS BETWEEN 120 PCF AND 122 PCF.	228
TABLE 37: OMC AND MAXIMUM DRY UNIT WEIGHT DETERMINATIONS BETWEEN 122 PCF AND 124 PCF.	229
TABLE 38: OMC AND MAXIMUM DRY UNIT WEIGHT DETERMINATIONS BETWEEN 124 PCF AND 126 PCF.	230
TABLE 39: OMC AND MAXIMUM DRY UNIT WEIGHT DETERMINATIONS BETWEEN 126 PCF AND 128 PCF.	231
TABLE 40: OMC AND MAXIMUM DRY UNIT WEIGHT DETERMINATIONS BETWEEN 128 PCF AND 130 PCF.	232
TABLE 41: OMC AND MAXIMUM DRY UNIT WEIGHT DETERMINATIONS BETWEEN 130 PCF AND 132 PCF.	234

TABLE 42: OMC AND MAXIMUM DRY UNIT WEIGHT DETERMINATIONS BETWEEN 132 PCF AND 134 PCF.	235
TABLE 43: OMC AND MAXIMUM DRY UNIT WEIGHT DETERMINATIONS BETWEEN 134 PCF AND 136 PCF.	237
TABLE 44: OMC AND MAXIMUM DRY UNIT WEIGHT DETERMINATIONS BETWEEN 136 PCF AND 138 PCF.	239
TABLE 45: OMC AND MAXIMUM DRY UNIT WEIGHT DETERMINATIONS BETWEEN 138 PCF AND 140 PCF.	240
TABLE 46: OMC AND MAXIMUM DRY UNIT WEIGHT DETERMINATIONS BETWEEN 140 PCF AND 142 PCF.	241
TABLE 47: OMC AND MAXIMUM DRY UNIT WEIGHT DETERMINATIONS BETWEEN 142 PCF AND 144 PCF.	242
TABLE 48: DETAILED RESPONSES TO SURVEY FORM 1.....	247
TABLE 49: DETAILED RESPONSES TO SURVEY FORM 2.....	248

ABSTRACT

COMPACTION TESTING OF GRANULAR MATERIAL

JASON JEROME WEBER

2018

The South Dakota Department of Transportation SDDOT uses the Ohio Highway Department's Typical Moisture Density Curves for performing compaction quality control on granular soil materials in junction with standard moisture density relations. The SDDOT also uses the Nuclear Density Gauge NDG, Sand Cone, and Rubber Balloon methods to conduct in-situ density tests. Compaction quality control of recycled pavements is conducted using test strips. The test strip method works well for large areas but becomes problematic for small areas. The ODOT Materials Manual states "Moisture-Density proctor curves and controls were originally developed to be used on cohesive (clays and silts) soils. Errors or complications arise when trying to extrapolate these principals to granular materials" (ODOT, 1998). The SDDOT has also been using more materials recycled from PCC pavements and asphalt concrete pavements as subbase and base courses. For these reasons the SDDOT wishes to reevaluate its current methods compaction quality control of granular materials.

A research synthesis report published by the National Cooperative Highway Research Program (NCHRP) has summarized alternative methods used by other DOTs for compaction quality control of granular materials (Nazzal, 2014). The research presented within this report includes the development of a new family of curves for SDDOT encountered base and subbase granular materials and also recommends Dynamic Cone Penetrometer (DCP) methods for compaction quality control of granular materials.

The research conducted included a literature review of various alternative forms of granular compaction quality control and analysis of the adequacy of using families of moisture density curves for granular compaction of base and subbase granular materials encountered by the SDDOT. The results of the research indicated that the currently used Ohio Highway Department's Typical Moisture Density Curves may be over predicting the maximum dry unit weight of base and subbase materials encountered

by the SDDOT. The results of an alternatives analysis also indicated that the DCP device may be the best alternative in-situ compaction testing device to meet the needs of the SDDOT.

1.0 INTRODUCTION

1.1 Problem Description

The SDDOT and other state DOT's have used the Ohio Highway Department's Typical Moisture Density Curves for the compaction of granular soils. However, the Ohio Department of Transportation (ODOT) Materials Manual states the curves and controls were originally developed to be used on cohesive (clays) soils. Errors or complications arise when trying to extrapolate these principals to granular materials (ODOT, 2017). Therefore, the SDDOT requests further information be gathered about the Ohio Highway Department's Typical Moisture Density Curves and an evaluation be conducted to determine the adequacy of their use with South Dakota's granular material.

The SDDOT is also using materials recycled from PCC and HMA as base course and subbase material (SDDOT, 2015a). Recycled materials are placed using the test strip method to determine the effective amount of effort needed to achieve acceptable levels of compaction. The method used for test strips by the SDDOT requires at least 500 feet in length for test strip construction. Test strips work well for large areas but become problematic for small areas (SDDOT, 2015a). New compaction quality control methods may need to be implemented that not only function efficiently for virgin materials but that can also be utilized effectively in a wide range of granular materials used in base course and subbase material applications.

SDDOT has identified a need to reevaluate how they determine whether granular material has been adequately compacted. Granular compaction quality control testing by the SDDOT has been conducted by determining target densities and OMCs through standard moisture density relations. In-situ testing is performed using the NDG or traditional sand cone method. Often target density and OMC values do not correlate to in-situ test values. This is due to a variety of factors such as differences in compaction effort and differences in the energy transfer to the soil between the field and laboratory compaction process. Density-based quality control is also relatively dependent on the person conducting the test. Results can vary dependent on the operator creating errors during density-based testing. These differences can contribute greatly to problems expressed by the SDDOT when conducting density-based compaction quality control of granular materials. These problems may be reduced by the implementation of new compaction quality control methods that do not rely on density measurements

but rather can be correlated to strength parameters of the material such as the California Bearing Ratio (CBR).

Some DOT's have started using new methods such as the LWD and DCP with success. These methods are easily correlated with various strength and stiffness parameters. Other states have been working with Intelligent Compaction (IC) technologies that relate strength parameters of the compacted material in real time from the construction compaction equipment. As other DOT's implement new compaction quality control methods, the SDDOT wishes to examine how other DOT's determine proper levels of compaction in granular subbase and base course. The SDDOT also wishes to determine whether the current Ohio Highway Department's Typical Moisture Density Curves are adequate for their needs or should be updated. It may be determined that the SDDOT needs to use different test methods to establish acceptable levels of granular compaction.

1.2 Research Objectives

The study has been designed to accomplish three main research objectives:

1) Evaluate the adequacy of using the Ohio Highway Department's Typical Moisture Density Curves for granular materials.

This objective was accomplished in several ways. An extensive literature review was conducted to gather knowledge of the Ohio Highway Department's Typical Moisture Density Curves. This included gathering information about how the curves were created and their history of use. Surveys were also utilized to gather information from surrounding DOT's. The surveys primary goal was to determine the extent of use of families of curves by surrounding DOT's. The surveys were also compared to results of the National Cooperative Highway Research Program (NCHRP) survey (Nazzal, 2014). Compaction data provided by the SDDOT was obtained to study the compaction characteristics of granular material types encountered by the SDDOT. The data collected was compared to the Ohio Highway Department's Typical Moisture Density Curves. Statistical analyses were performed to compare the data to the Ohio Highway Department's Typical Moisture Density Curves. The analyses are summarized in Chapter 3 of this report.

2) Identify existing and possible alternatives for determining target density of granular bases.

This objective was accomplished by conducting a thorough literature review. The literature was abundant with current studies that contain information that adequately addressed this research objective. Surveys were also sent to surrounding DOT's to gather information on alternative compaction testing methods. A detailed summary of the reviewed literature is presented in Chapter 2 of this report. Chapter 3 presents a summary of the survey results.

3) Determine whether an alternative method of testing compaction of unprocessed and recycled granular material should be used.

Based on the findings of the first two objectives, alternatives were identified that could be beneficial to the SDDOT. The methods that showed the most promise relied on measurements related to stiffness and strength modulus. The determination of the most appropriate methods was selected based on an abbreviated alternatives analysis. The comparison criteria included accuracy, precision, ease of

use, repeatability, reliability of data, safety, test time, and the level of expertise required. The team also considered impacts to construction specifications and correlation of device measurement results to material properties (e.g., density, modulus, stiffness, moisture content). Calibration, durability, and compatibility of each method with various granular materials was also considered. Advantages and disadvantages of each device was presented in Chapter 2 of this report. Chapter 4 presents the analysis used to recommend the most desirable alternative field testing device to meet the SDDOT's needs.

1.3 Task Descriptions

The research project was divided into 10 tasks. The following section briefly describes each task and in what chapter of this report the results are presented. A listing of each task along with explanation of activities involved follows.

Task 1: *Meet with the technical panel to review the project scope and work plan.*

A kick off-meeting occurred on August 27, 2015 at the SDDOT office in Pierre, South Dakota. The research team prepared a presentation on the scope and work plan for the project. The meeting also served to gather detailed information on the needs of the SDDOT in terms of compaction of new and recycled granular materials. It was important to the research team to obtain additional details of the SDDOT's testing methods and specifications as it pertains to granular compaction.

Task 2: *Review and summarize literature pertinent to compaction testing of granular material.*

A comprehensive literature review was conducted on compaction testing of granular materials as it applies to SDDOT compaction testing. The review focused on both project development and compaction testing of granular materials relative to current SDDOT methods and specifications. Alternative compaction testing methods were summarized with advantages and disadvantages to each as it relates to the SDDOT's current needs.

Although this task was mainly a review of the published literature, understanding current SDDOT practices was also important to the project. Therefore, an additional meeting occurred with selected SDDOT technical panel members at the South Dakota State University main campus in Brookings, South Dakota on June 21, 2016. The meeting was conducted to gather information about current SDDOT methods and specifications. It was important to the research to understand additional details of the SDDOT's difficulties as it pertains to their current granular compaction testing methods. The results of the literature search were used as the basis for completing follow-on research tasks as well as the development of recommendations. The information gathered from this task was evaluated relative to the Research Objectives and are summarized in Chapter 2 of this report.

Task 3: *Survey other state DOT's and federal agencies to document their methods, testing frequencies, procedures, equipment, and training requirements for granular compaction testing.*

A NCHRP study (Nazzal, 2014) conducted a comprehensive survey of most state DOT's regarding compaction quality control of unbound materials. Additional information needed from DOT's beyond that study were Identified to benefit this study. This information was collected through direct survey. Two additional surveys were created to collect needed information to discern the aspects and processes by which they conduct compaction quality control. One survey was sent to surrounding DOT's that did not participate in the NCHRP survey and another was sent to states that did participate to avoid unneeded repetition. The surveys were reviewed by the SDDOT technical panel before being forwarded to state DOT's for their responses. The results of the surveys are summarized in Chapter 3.

Task 4: *Compile data from past SDDOT granular material density tests and compare it to Ohio Curves to determine whether the curves can be used, new curves are needed or the department shouldn't use the curves and move to using a different method.*

This task required the research team, through the SDDOT Office of Research, to obtain existing data of compaction testing. Data was compiled by the SDDOT after the June 21, 2016 meeting. The data was taken from several SDDOT sources that pertained to granular compaction testing and was provided in a spreadsheet format. The data was then conditioned, analyzed, and compared to the Ohio Highway Department's Typical Moisture Density Curves. This included statistical analyses of the data to determine the adequacy of using the Ohio Highway Department's Typical Moisture Density Curves for granular compaction quality control. It also included the creation of a new family of compaction curves to complete the comparative analyses. The lines of optimum for each family were compared to determine if a significant difference existed. A detailed summary of the analyses is presented in Chapter 3 of this report.

Task 5: *Determine the most appropriate compaction testing method for virgin granular materials and granular materials incorporating recycled materials by analyzing the survey and SDDOT density data.*

Based on the information gathered in Task 1 through Task 4, methods for verifying compaction of granular materials were analyzed relative to the SDDOT needs. The team then compared alternatives summarized in Chapter 2 to recommend which alternatives best matched the needs identified. The needs considered for each alternative were accuracy, precision, ease of use, repeatability, reliability of data, safety, and test time. Calibration, durability, and compatibility also were considered.

These aspects of each alternative were compared with the relative cost of each alternative presented in the literature. Advantages and disadvantages of each alternative are summarized in Chapter 2.

Recommendations are presented and summarized in Chapter 6. It was the goal of the research team that the recommended new methods be applicable in a wide range of granular and recycled materials and increase on-site testing efficiency.

Task 6: *Meet with technical panel to review work completed on previous tasks and to present recommendations on adequacy of using Ohio Curves and new compaction testing equipment or procedures.*

A meeting between the research team and the technical panel was held in Pierre, South Dakota on April 11, 2017. The meeting was conducted to present the initial results of the study. That included a summary of the literature review, survey results, tabulated data, analysis methods, and analysis results. The research team also presented recommendations for alternatives for granular compaction quality control and/or a new family of compaction curves. The technical panel confirmed the findings and recommendations, and directed the research team to finalize the project work.

Task 7: *Prepare policies, procedures, or specifications needed to adopt new or revised compaction testing methods.*

Based on the methods recommended by the research team and confirmed by the technical panel, the research team prepared the necessary technical documents for the SDDOT implementation. The documents included a DCP procedure, methods for use of the DCP in a variety of material types and applications, and supplemental specifications. A revised method for using the new family of compaction curves was also created. The documents were created to follow current SDDOT formats. These documents were based on existing compaction testing methods gathered in the literature search. The produced documents were sent to the SDDOT Technical Panel for review and comment. The documents are presented in Appendix A.

Task 8: *Estimate the cost, including personnel and equipment, of changing from current compaction methods.*

Based on the procedure, methods, and specifications produced in Task 7, costs the SDDOT will incur to implement the recommended changes were determined. These costs included necessary personnel and equipment costs for implementation. Unit personnel costs were provided by the SDDOT and used to estimate administrative implementation, technical training of field personnel for implementation, and technical support costs. Equipment costs were also estimated and included the necessary field and laboratory equipment to implement the revised and new compaction testing methods. Costs were developed in end-of-project dollars and can be escalated for the year of implementation. Costs are summarized in Chapter 6 of this final report.

Task 9: *In conformance with Guidelines for Performing Research for the SDDOT, prepare a final report summarizing the research methodology, findings, conclusions, and recommendations.*

The report documents the project results including compaction methods and survey results, findings, conclusions, and recommendations. This report also includes an implementation plan that will guide the SDDOT in maximizing the benefits from the research. This implementation plan is presented in Chapter 6. The final report was submitted to the SDDOT Technical Panel for review and revisions were made to incorporate comments.

Task 10: *Make an executive presentation to the SDDOT Research Review Board and the conclusion of the project.*

An executive presentation will be made by the Principal Investigator (PI) to the SDDOT Research Review Board in Pierre, South Dakota at the conclusion of the study. The presentation will summarize the research activities that were accomplished in this project and all conclusions and recommendations that resulted from the research.

2.0 LITERATURE REVIEW

This chapter presents a review of literature relevant to the compaction testing of granular soil materials used by the SDDOT. The review covers literature relevant to compaction fundamentals, field and laboratory compaction, and compaction testing of granular soils. This review also summarizes the suitability of different types of granular families of curves. Additionally, the review documents new technologies developed to establish proper compaction of granular and recycled materials.

2.1 Fundamentals

Granular materials have engineering properties that influence their performance and vary with gradation. For granular materials, the key functional properties are stiffness and strength, which are measures directly related to their structural performance (Nazzal, 2014). Stiffness and strength of soils are used in the mechanistic design of pavement thickness (Christopher et. al, 2006). The main purpose of compaction is to increase the stiffness and strength of materials by increasing dry unit weight and decreasing the void ratio. The dry unit weight of soil material is used as a measure or proxy of the engineering properties of that soil, but there is no unique relationship between moisture-density measurements and the soil stiffness or strength (Reid, 2001). Thus, there is no direct connection between the design process and compaction quality control of a fill.

Furthermore, the SDDOT currently relies on the Ohio Highway Department's Typical Moisture-Density Curves Set C, Figure 7 for development of target densities. Although this family of compaction curves works well for clays for which they were developed, they become problematic when determining target densities of granular materials. The next two sections will include a comprehensive definition of granular materials.

2.1.1 Granular Materials

The definition of granular materials differs among different classification systems AASHTO M 145 (AASHTO, 2015a) and ASTM D 2487-11 (ASTM, 2016a). The American Association of State Highway and Transportation Officials (AASHTO) system used by the SDDOT defines a granular material as a material in which less than 35 percent of the material by weight passes the No. 200 (0.075-mm) sieve. AASHTO M 145 also groups different soil classifications by sieve analysis particle

distributions and ranks them on their suitability for subgrade construction. Granular materials are classified under groups A1, A2, and A-3. Table 1 presents the sieve analysis specifications for granular material according to AASHTO standards. It was constructed in close relation to tables presented in AASHTO M 145-2 of the AASHTO Standards Specifications for Transportation Materials and Methods of Sampling and Testing and AASHTO Provisional Standards Manual (AASHTO, 2015a). The table describes the gradation characteristics and typical constituent materials for each granular material AASHTO grouping. Notice that the group classification for A-2 granular materials is divided into four subgroups or index groups from A-2-4 to A-2-7. The last number of this group classifications is known as a partial group index.

Table 1: AASHTO classification of soil-aggregate mixtures for granular materials.

General Classification	Granular Materials (35 percent or less passing No. 200)						
Group Classification	A-1		A-3	A-2			
	A-1-a	A-1-b		A-2-4	A-2-5	A-2-6	A-2-7
Sieve Analysis, percent passing							
2.00 mm (No.10)	50 max
0.425 mm (No. 40)	30 max	50 max	51 min
0.075 mm (No. 200)	15 max	25 max	10 max	35 max	35 max	35 max	35 max
Usual types of significant constituent materials	Stone fragments, gravel, and sand		Fine sand	Silty or clayey gravel and sand			

The particles that pass the No. 200 sieve are referred to as fines and often consist of small plastic and / or non-plastic particles. The range of granular materials can be divided into classifications of free draining and semi-draining based on their interaction with moisture. Drnevich, (2007) characterized free draining material as one that consists of less than 35 percent non-plastic fines or less than 15 percent plastic fines. AASHTO differentiates between plastic and non-plastic fines for granular material through a group index formula. The index formula chart is shown in Figure 1 and relies on the liquid limit and plasticity index of a material to determine the partial group index number. For granular material between A-2-4 and A-2-7 only the plasticity index is used in the calculation. A-2-4 and A-2-5 materials contain a majority non-plastic particles within the fines content and are classified as silty granular material. A-2-6 and A-2-7 soils contain a majority of plastic fines and are classified as clayey granular material.

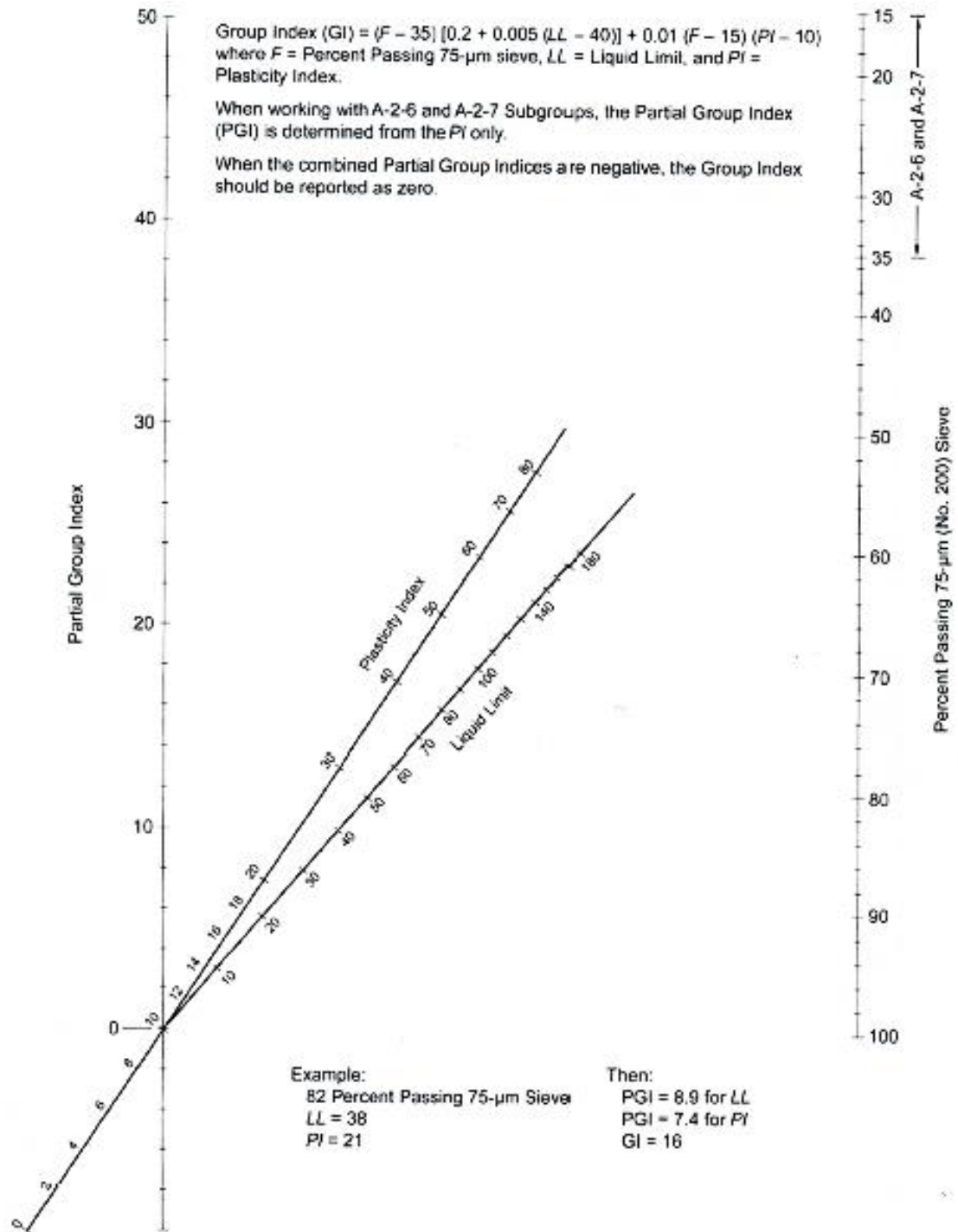

Figure 1: AASHTO M 145 Group Index Chart (AASHTO, 2015a).

Semi-draining materials defined by Drnevich (2007) contain small portions of fine particles from 15 to 35 percent and develop fairly-well defined maximum dry unit weights and OMCs through

traditional laboratory impact compaction testing. For free draining granular materials, a lack fine particles results in poorly defined maximum dry unit weights. Often relative compaction results for these materials do not correlate well with the materials engineering properties (Drnevich, 2007). This is due to the effect of moisture on materials of differing gradation, which will be discussed with more detail in the following section.

2.1.2 Semi Draining and Free Draining Granular Materials

Drnevich (2007) presented that when compacting granular materials, the effects of moisture content vary between semi-draining and free-draining granular materials. He states that since free-draining materials are constantly draining, two moisture contents can be observed. The first moisture content can be measured immediately before compaction and the second after compaction. For cohesive soils and most semi-draining materials these two moisture contents are relatively close together but for free-draining material these measurements are of greater separation. Moisture content prior to compaction is the most important moisture measurement to establish effective rearrangement of soil particles during compaction. However, the moisture content is typically measured in the field after compaction. Drnevich (2007) states that after compaction the moisture content will decrease due to the draining characteristics of free-draining materials and potential evaporation depending on weather conditions.

Free-draining materials, however, behave much differently when laboratory impact compaction methods are utilized at varying moisture contents. Figure 2 shows the irregularity of the curve can be contributed to capillary stresses that exist under low moisture contents. The moisture contents in which these capillary stresses develop are referred to as bulking moisture contents Drnevich (2007). At these bulking moisture contents, a curved surface develops at the water-air interface due to the difference between the air and water pressures. Rathje (2006), states difference in pressure can be referred to as matric suction, which creates tension stresses that hold soil particles in place and resist the compaction effort. The curved water surface between particles possess tension that draw particles together and increases sliding friction. These capillary stresses are reduced when moisture is removed or the soil approaches saturation. Ba (2013) presents a correlation between matric suction and the resilience

modulus of granular materials. They concluded that the resilience modulus correlates better with matric suction than with the compacted moisture content because in-situ matric suction and the resilience modulus both depend on the same stress state.

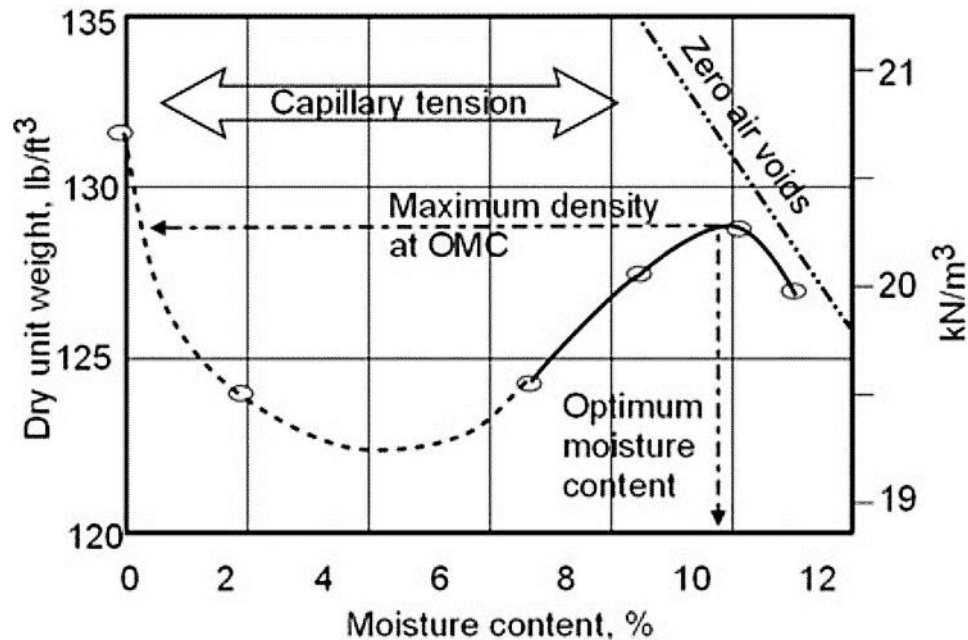

Figure 2: The moisture density relationship for free draining granular soil (Drnevich, 2007).

Drnevich (2007) explained that for many granular materials, the maximum dry unit weight occurs at either the oven-dry or nearly saturated condition. It has been observed that the maximum dry unit weights at saturated conditions are limited to free-draining materials, but effective laboratory compaction at oven-dry condition worked well for materials with up to as much as 30 percent fines. The complete removal of water from a free draining granular material is rather unrealistic for field applications. Therefore, free draining granular soils require thorough wetting prior to effective compaction.

It has been summarized that water contents can have varying effects on the engineering properties of materials with different gradations. The most common form of laboratory compaction verification specifies that all soil classifications (clays, silts, granular, etc.) effectively compact in a similar fashion at varying moisture contents. It has also been shown that for differing material gradations, the compaction energy can be delivered by more effective methods within a laboratory. These differing methods of delivering compaction energy are also more relatable to compaction

energies observed in the field. The methods of delivering effective compaction energy as they relate to testing proper compaction of granular soils are summarized in the following section.

2.2 Effective Laboratory Compaction Test Methods

Compaction is the densification of a soil through the expelling of air voids by the application of energy. There are four types of compaction efforts used to measure soil compaction: impact compaction, pressure compaction, kneading compaction, and vibratory compaction. These compaction methods are all useful for both laboratory tests and in-situ compaction using a variety of equipment. Impact compaction tests are the most common compaction verification effort used throughout the engineering industry (Nazzal, 2014). This is most likely because it stems from the first standardized “compaction test” widely accepted by the engineering industry. It is important that laboratory test methods be summarized within this report as they may be influencing problems with the current SDDOT field compaction test methods for granular materials. Therefore, this section will focus on summarizing traditional laboratory impact compaction test methods and laboratory vibratory compaction test methods as they relate to granular compaction.

2.2.1 Impact Compaction Methods

The “standard” laboratory impact compaction test used today is known as AASHTO T 99 (AASHTO, 2015b). For the remainder of this report it will be referred to as the standard laboratory compaction tests. This method is also known throughout the industry as the “Standard Proctor Compaction Test” and was originally developed based on studies performed in the 1930s by R. R. Proctor (Nazzal, 2014). Proctor’s study performed penetration resistance tests to determine the indicated saturation resistance for several compacted earth fills. The test was originally designed to simulate the action of a sheep foot roller as a penetration resistance measurement test for fine grained soils such as clays for dam construction. The tests development was influenced by a common on-site method used to evaluate soil compaction at the time known as roller “walk out” in which the feet of the sheep foot roller would begin to move up out of the soil layer upon effective compaction. To illustrate the idea Figure 3 shows roller “walk out” was due to an increase in soil bearing capacity due to the compaction and kneading efforts of the roller. However, due to a printing error, the test was adopted by

many organizations as a standard compaction test (Nazza, 2014). Due to the error, soil dry density is now used as a standard of soil compaction testing for most organizations rather than penetration resistance (bearing capacity).

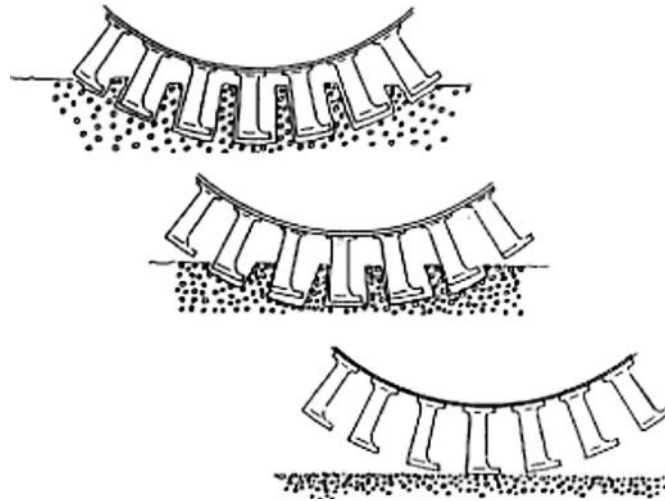

Figure 3: The process of sheep foot roller “walk out”.

From Proctor's work, scientists identified a relationship between soil particles and moisture content. Researchers compacted clay samples isolating only moisture content, keeping all other compaction variables constant. By imparting impact energy at varying moisture contents, they discovered that at certain moisture contents called the OMC, a maximum dry unit weight was determined. It was theorized that the moisture between these clay particles acts as lubrication that allow the imparted energy to more easily rearrange fine soil particles into a denser arrangement, however, this was not correct (Drnevich, 2007). Moisture creates hydrogen bonding between clay particles pulling the particles closer together, increasing not only the unit weight but also the strength of the soil. In soil materials that do not contain clay particles such as granular unbound materials, this reaction does not occur. Figure 4 shows this traditional relationship between moisture content and dry unit weight.

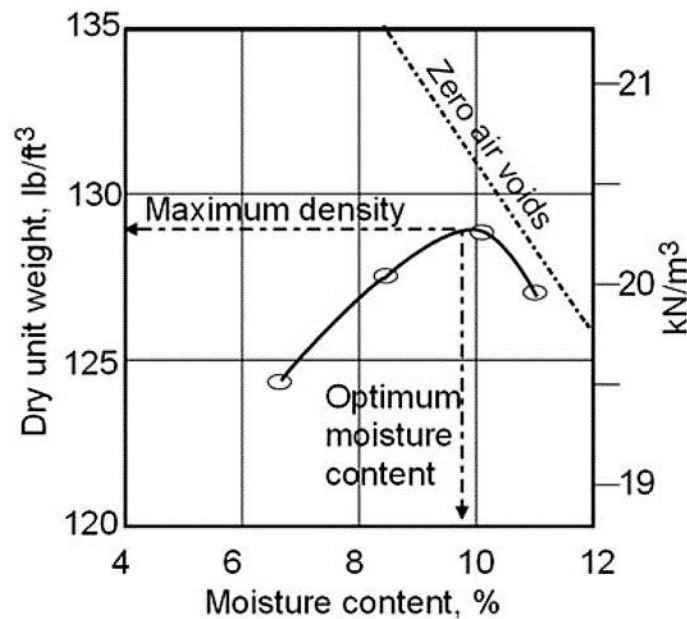

Figure 4: Moisture density relationship cohesive fine grain soils (Drnevich, 2007).

The standard laboratory compaction test involves imparting energy by means of a drop rammer, hence its classification as an impact compaction test method. For cohesive soils, impact compaction is an effective method of delivering compaction effort due to the kneading process that each impact imparts on the soil particles. The kneading process facilitates moisture penetration into soil allowing hydrogen bonding between clay particles to occur. The standard laboratory compaction test also compacts fine grain soils in a similar fashion to the way they are compacted in the field with the use of a sheep foot roller. When tests are performed at varying moisture contents, a clear peak in the curve develops for cohesive soils.

If the material type or imparted energy in the field differs significantly from the reference material or compaction effort in the lab, the computed relative compaction will not be meaningful and valid (Drnevich, 2007). The compaction energy imparted on fills today is much different than those of the 1930s due to the advancements in compaction equipment used on construction projects today. This presents a problem when relating field compaction measurements to target density values created in the laboratory using impact compaction equipment not designed to be similar in compaction energy.

However, changing the number of rammer drops per layer, the weight of the rammer, and the height of each drop modifies the imparted energy.

This problem was addressed to better represent the compaction effort required on large airfields. The U.S. Army Corps of Engineers in 1958 developed a modified proctor test known as AASHTO T 180 (AASHTO, 2015c). For the remainder of this report, this laboratory compaction method will be referred to as the modified laboratory compaction tests. The modified laboratory compaction test uses a larger mold with more layers, a heavier drop rammer at a longer drop height, and more drops per lift. The modified laboratory compaction test uses compaction effort approximately 4.5 times greater than that of the standard laboratory compaction test. The differences in parameters between the two tests are shown in Figure 5. There is a difference of 4.5- lb in rammer weight between the two tests and a drop height difference of 6-in. The modified laboratory compaction test also uses five compaction layers unlike the standard laboratory compaction test which only specifies three compaction layers. Many problems still arise however, when performing the modified compaction test on granular materials.

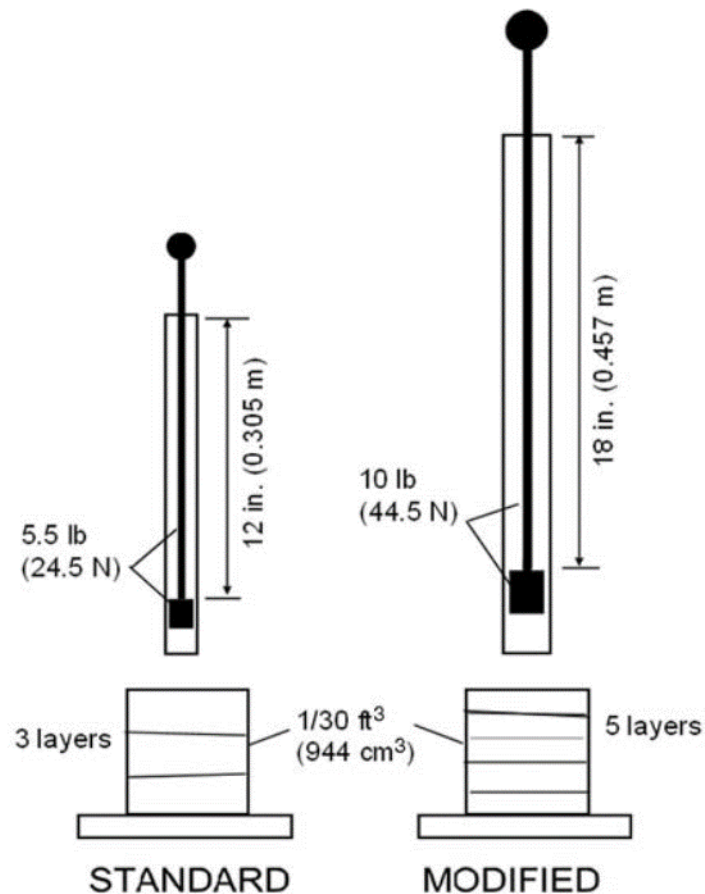

Figure 5: Parameter comparison of standard versus modified laboratory compaction tests (Felt, 1958).

Felt (1958) states impact compaction is not an appropriate compaction mechanism for compaction of granular soils. Without cohesion of fine clay particles, soil particles displace with each rammer drop when traditional impact compaction tests are performed. As previously discussed, due to the gradation of these soils, the engineering behavior is much different, therefore, laboratory compaction methods must address these differences.

Vibrating roller technology is used to effectively compact granular material in the field although the laboratory compaction tests use impact compaction. Drnevich (2007) states that sixty percent of state DOT's specify only 95 percent of Standard Proctor maximum dry unit weight for compaction control. Drnevich (2007) also observed differences in compaction effort between the field and the laboratory while studying relative compaction in the field. He observed that contractors do not have difficulty achieving required relative compaction in the field, even when moisture contents are not

optimum. This could be an indication that the maximum dry unit weight achieved by the standard laboratory compaction tests are inappropriate. It has also been observed that excessive settlement often occurs in granular materials where the specified field compaction is based on standard compaction tests maximum dry unit weights. These observations support addressing laboratory compaction methods for granular materials.

2.2.2 Vibratory Compaction Methods

Drnevich (2007) conducted an evaluation of alternative laboratory test methods for granular soil compaction to address the problems with laboratory testing for maximum dry unit weight of granular materials. The main objective of the evaluation was to assess a laboratory vibrating hammer compaction test as an alternative to the standard laboratory impact compaction test for granular soils. Another main objective of the testing was to develop a better definition of granular soil based upon compaction behavior. Defining a range of soils appropriate for each type of laboratory compaction test both impact and vibratory was important to the research.

The testing performed various compaction tests on soils classified by both the AASHTO M 145 (AASHTO, 2015a) and the American Society for Testing Materials ASTM D 2487-11 (ASTM, 2016a) classification systems. The compaction tests performed included vibrating hammer tests, standard laboratory compaction tests modified laboratory compaction tests, vibrating table compaction tests ASTM D 4253-16 (ASTM, 2016b), and minimum unit weight determinations. The vibrating table method standard state that the test be performed on granular soils with less than 15 percent passing the No. 200 sieve (fines). However, to compare the various test methods to the vibration hammer compaction method, soils were compacted regardless of the amount of fines present.

Based on compaction curves obtained by the vibrating hammer tests, a normalized family of compaction curves was developed. As moisture contents increased, peaks in dry unit weight did not develop until the ratio of moisture content to saturated moisture content (w/w_{ZAV}) was between 0.8 and 1.0. A maximum dry unit weight was obtainable for granular soil samples with moisture contents between 80 percent and 100 percent of saturation. Therefore, performing one vibrating hammer

compaction test on an oven-dry sample will provide a maximum dry unit weight that can be used to calculate the moisture content range in which effective compaction will occur in the field.

The procedure is similar to the vibrating table test ASTM D 4253-16 (2016b) in which maximum dry unit weight is determined at oven dry or saturated conditions. However, the maximum dry unit weight when using the vibrating hammer tests usually occurs at the oven-dry condition. The vibrating table test, ASTM D 4253-16 (2016b), also does not provide a moisture content range, which is critical for compaction in the field.

In conclusion, a pilot implementation project showed that the vibrating hammer method of compaction can be used when evaluating compaction of aggregate bases. The vibrating hammer test provides a range of moisture contents for the time of compaction to achieve efficient compaction assuming compaction equipment delivers energy similar to laboratory vibrating hammer compaction test (Drnevich 2007).

2.3 Traditional In-Situ Compaction Test Methods

Traditional field compaction test methods have been used for all classifications of soils for decades. These methods include sand-cone test methods, balloon test methods, and NDG test methods. These field test methods have both AASHTO and ASTM standard test methods and versions of these tests methods are all currently in use by the SDDOT. The SDDOT along with several other state agencies also have test specifications for the use of family of compaction curves in conjunction with traditional field compaction test methods. These families of compaction curves are created from individual moisture-density relations. One-point density determinations of dry unit weight are plotted with a family of compaction curves to determine target density. Traditional field compaction tests are then compared with target density to determine adequate levels of compaction. The next few sections will summarize traditional field compaction methods and the use of families of compaction curves.

2.3.1 Families of Compaction Curves

As previously discussed laboratory compaction curves that can relate moisture content and dry unit weight have been used for decades to provide engineers the ability to facilitate quality control of

compaction on soil construction projects. These curves also can provide useful information on a given soils sensitivity to water (Horpibulsuk, 2009).

Target field density and OMC is most commonly determined using impact compaction tests. In a survey of 41 DOT's conducted in 2014, most use the standard compaction test method AASHTO T 99 (AASHTO, 2015b) and the modified compaction tests method AASHTO T 180 (AASHTO, 2015c) or a modified version of those standards to establish the target field density value (Nazzal, 2014). However, the SDDOT along with two other state DOT's (Delaware and Ohio) indicated that they use the Family of Curves-One-point Proctor Method AASHTO T 272-15 (2015f) based on families of curves that they have developed or adopted to determine the target field density value (Nazzal, 2014).

The Family of Curves-One-Point Method AASHTO T 272-15 (2015f) is an impact compaction test that was developed to determine maximum density and OMC of materials utilizing only one point measurement of density and moisture content. The method uses the same standard laboratory compaction test standards as the standard laboratory compaction test previously discussed to determine the density of a field sample at moisture content assumed to be near optimum. The moisture density relation is then plotted with a family of compaction curves and the closest curve to the point is assumed to be the compaction curve for that material. The curves are predetermined compaction curves with similar shape and geometry of various soils tested.

The SDDOT currently uses a modification of the Ohio Highway Department's Typical Moisture Density Curves Set C to establish target moisture density values. The Ohio Department of Highways created the first set of curves as it became apparent that individual moisture density curves used in one part of the state could be used by another part. Provided the curves were made of soils of similar weight, regardless of the source of supply (Joslin, 1958). Initial set of curves developed by K. B. Woods, were divided by 5-lb intervals of dry unit weight starting at 80 pounds per cubic foot (pcf) and ending at 144-pcf. Divisions were also made for each 2 percent moisture. The wet unit weight, dry unit weight and penetration resistance values were all recorded and then averaged and plotted on graph paper (Joslin, 1958). The first set of curves was created in 1936 from the results of 461 soil embankment samples. The first set of curves, Set A, can be seen in Figure 6.

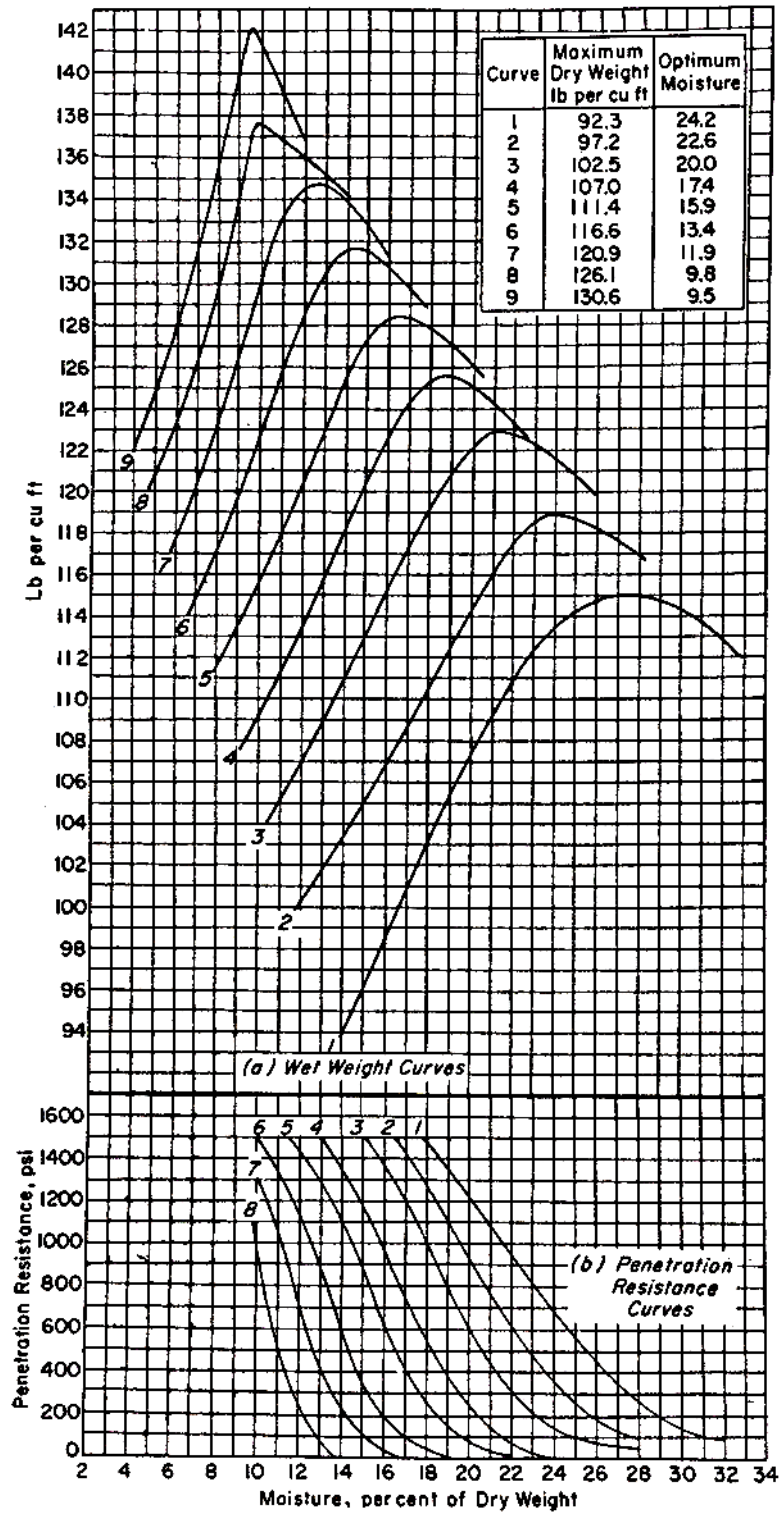

Figure 6: Typical embankment control curves, set A (Joslin, 1958).

Additional compaction data was added to the original curves seen in Figure 6 to create two updated sets of typical curves with the most extensive and accurate being the final set, set C shown in Figure 7. In set C, created in 1949, a total of 26 typical curves with dry weights ranging from 81-pcf to 142-pcf and were the result of 10,149 tests (Joslin, 1958). Figure 7 illustrates set C along with the 26 typical curves labeled from A to Z and includes 13 interpolated curves. The accumulation of curve data was collected from 1935 to 1949 and ended when data no longer improved the typical moisture density curves (Joslin, 1958). When determining the correct typical curve, the penetration resistance curve was also used to correlate the correct curve. For soils that penetration resistance tests could not be conducted such as granular soils, the penetration resistance tests were not recommended to aid in the determination of the correct curve. A Typical Curve Circular Slide Rule was created to increase the efficiency of using the curves in the field seen in Figure 8. This allowed engineers in the field to more rapidly select the proper curve of each soil.

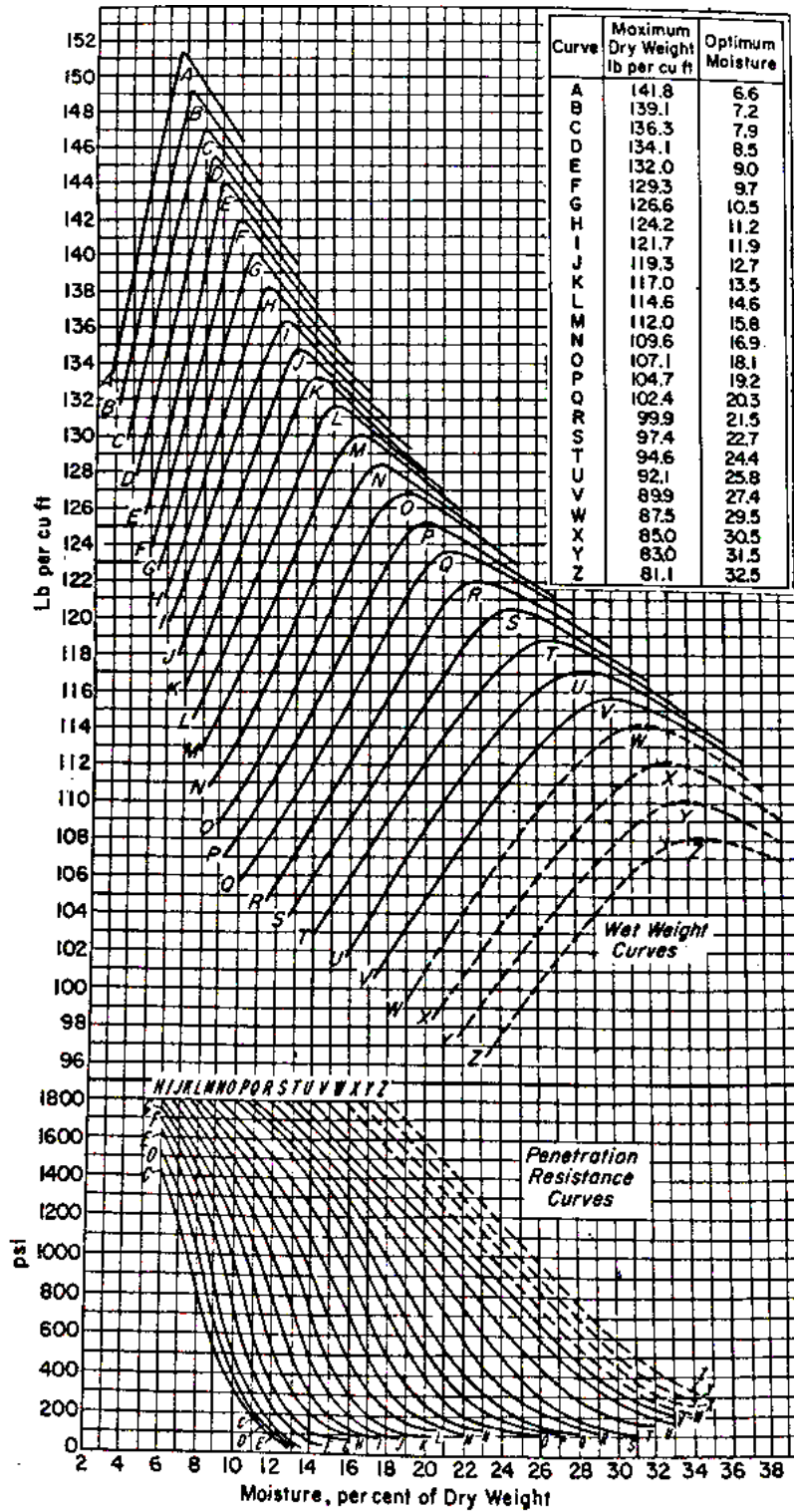

Figure 7: Ohio Highway Department's Typical Moisture Density Curves, Set C, May 1949 (Joslin, 1958).

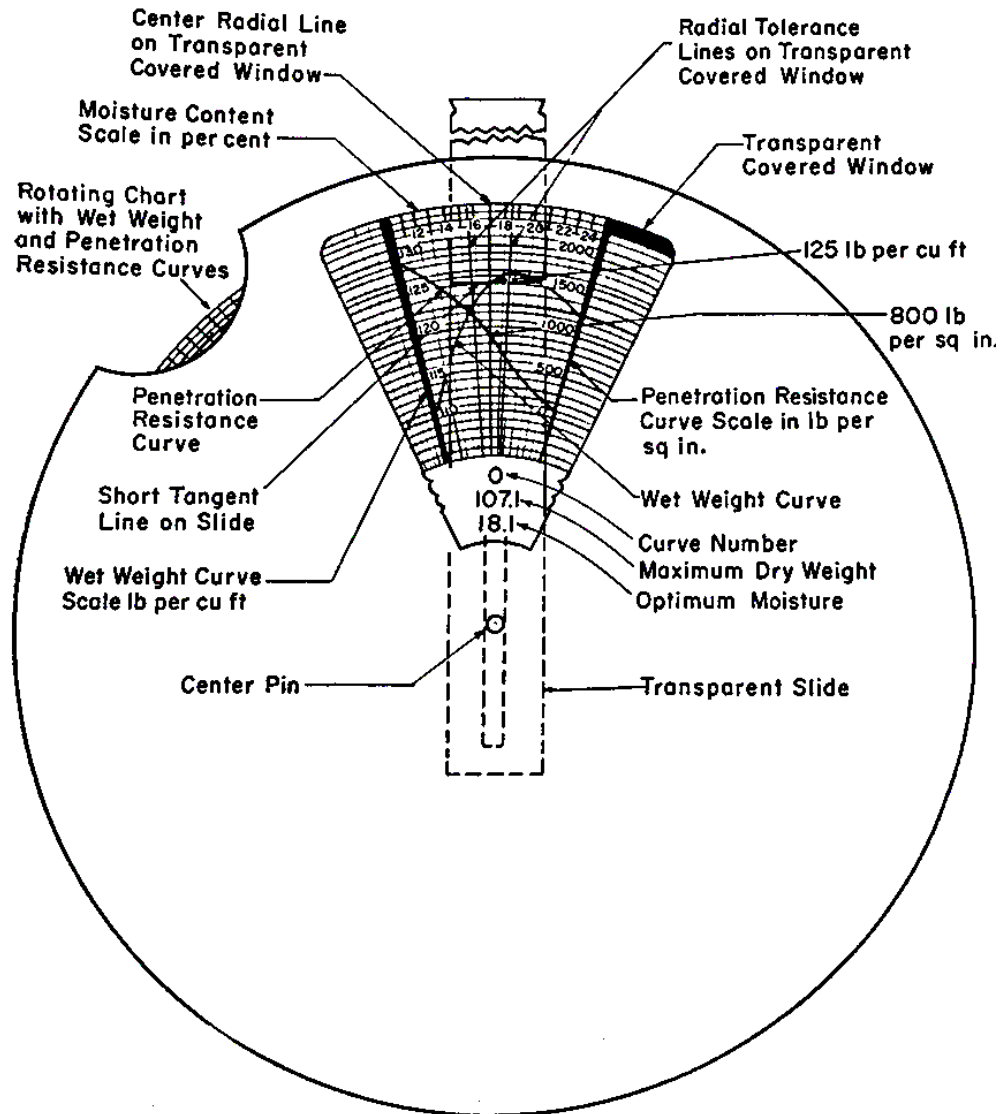

Figure 8: Typical Curve Circular Slide Rule (Joslin, 1958).

The SDDOT adopted Ohio Highway Department's Typical Moisture Density Curves Set C and added an additional 26 interpolated curves to the model which doubled the number of typical curves from 26 to 52 typical curves as seen in Figure 9. The SDDOT also does not conduct penetration resistance tests to aid in the determination of the correct curve, rather the resulting moisture density relations of standard laboratory compaction tests are compared with the selected curve to verify the use of the compaction curves for each material to be tested. This method is referred to as an end-products method of material testing. Reid (2001) described this method of constantly establishing a target density as time consuming to project inspectors. Additionally, contractors are constantly waiting on feedback

from the inspectors, which can delay projects. Reid (2001) also states that in some cases it can take up to an hour to complete just a single one point determination of dry unit weight.

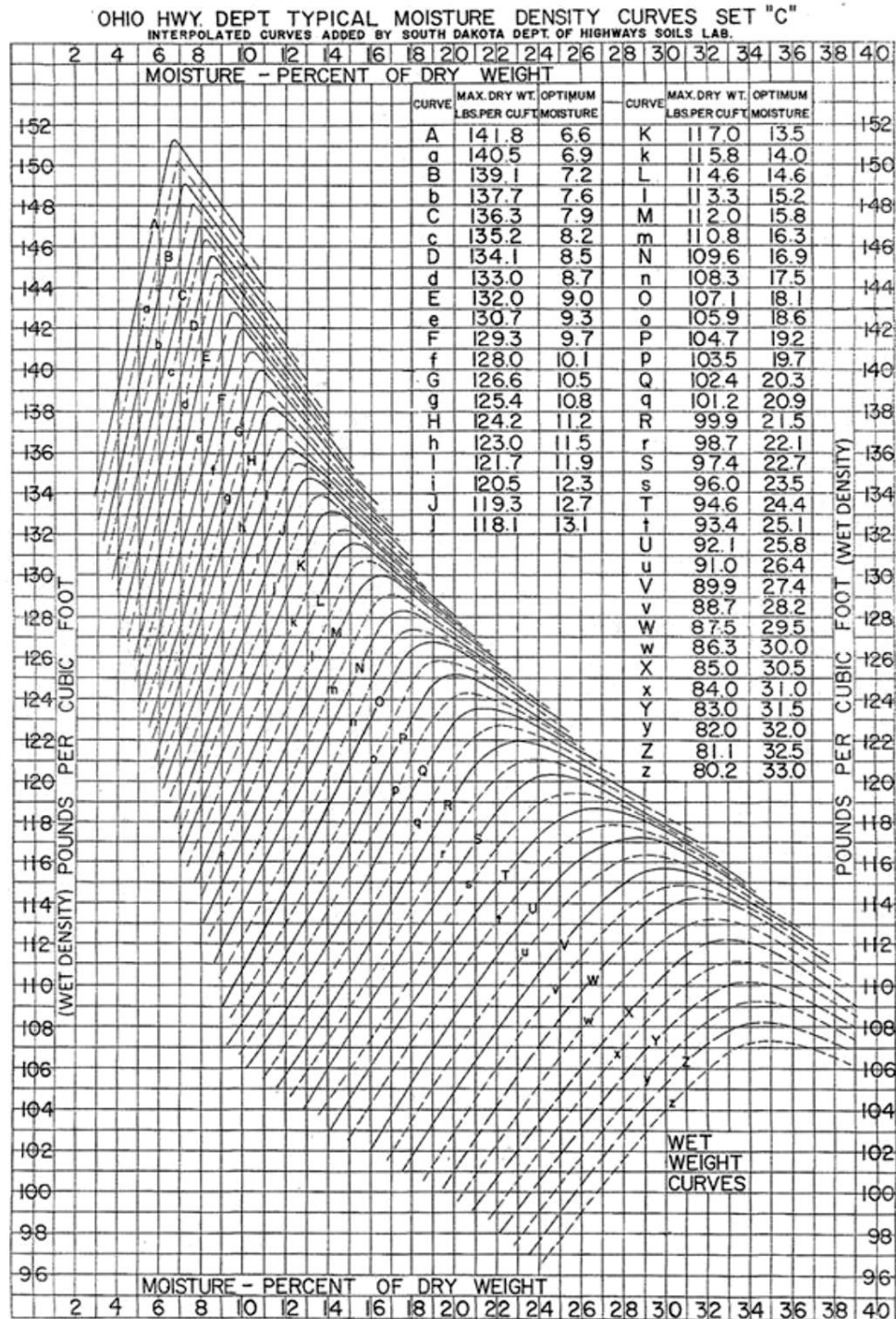

Figure 9: Ohio Highways Department's Typical Moisture Density Curves, Set C with interpolated curves (SDDOT, 2015a)

According to AASHTO T 272-15 (2015f), the family of compaction curves used to obtain moisture density relationships must adequately represent the entire mass range and all soil types of material for which the family is to be used. If soil types that differ greatly and are not represented on one general family of compaction curves, a separate family of compaction curves can be developed. Furthermore, materials with widely varying geological origins must be carefully checked to determine if separate families are required.

The AASHTO T 272-15 also outlines that the accuracy of a family of compaction curves can be verified by comparing the maximum density and OMC from an individual moisture density relationship with that obtained using the family of compaction curves and the one-point methods. The difference between these values represents the maximum variance expected when the family of compaction curves and the one-point methods are used for the given individual material. Based on the results of the comparison, adjustments to the curve may be needed or certain material types may not be applicable of the given family of compaction curves. A family of compaction curves with fewer moisture density relationships should be examined more closely (AASHTO, 2015f).

2.3.2 In-Situ Compaction Verification Using Traditional Sand-Cone Test Method

The standard method for the determination of in-place soil density by means of a sand-cone is performed in accordance with the AASHTO T 191-14 (AASHTO, 2015d). The method is known as a volume replacement test method and is destructive in nature. The procedure requires a small hole be excavated in the compacted soil. The hole is then filled with sand of a predetermined density. The volume of the hole is then measured, and the material extracted is weighed to determine the density of the compacted layer. Figure 10 shows the sand-cone apparatus.

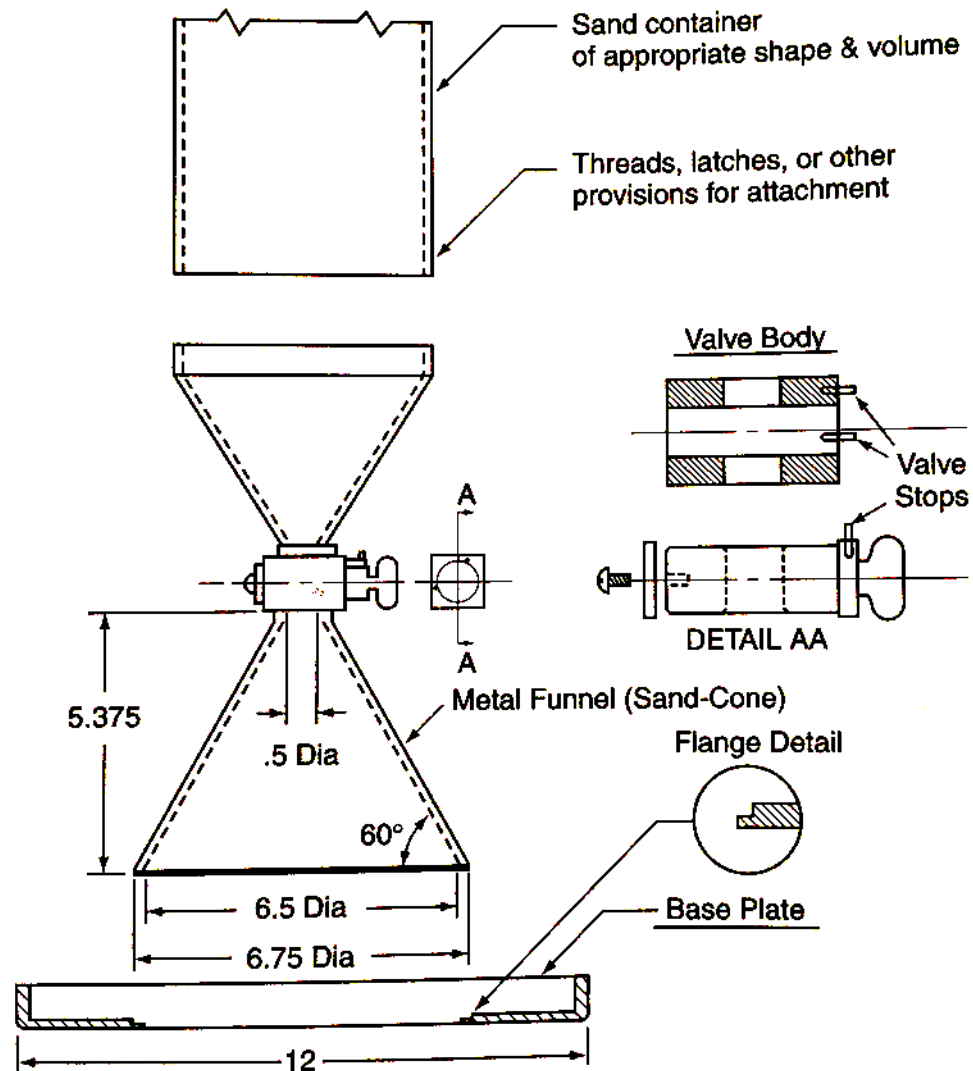

Metric Equivalents

in.	mm
.5	12.5
5.375	136.5
6.5	165.1
6.75	171.5
12	304.8

No Scale

Figure 10: In-situ sand cone density test apparatus (Liu and Evett, 2000).

The accuracy has been found to depend on the experience of the operator. Therefore, it was not found to be repeatable for use as a compaction control tool in the field (Farrag, 2005). Ernest et. al (2013) found that traditional sand cone tests work effectively with a few limitations. Ernest et. al (2013) state that the sand cone method was limited to soils with a particle diameter size of less than one inch in

effective diameter. They also state it is difficult to conduct tests in cohesionless materials. Methods that replace the sand with steel shot of a known density has also been evaluated and were found to be even less effective than the traditional sand cone (Ernest et. al, 2013).

2.3.3 In-Situ Compaction Verification Using Traditional Rubber-Balloon Test Method

The standard method for the determination of in-place soil density by means of a rubber-balloon is performed in accordance with the ASTM D 2167-66 (ASTM, 2016f). The rubber-balloon test method is similar to the sand cone test method in that it is a destructive volume replacement test method. The rubber-balloon method differs primarily from the sand cone method in the manner in which the volume of compacted soil removed is determined. In the rubber-balloon method, a quantity of compacted soil is removed and weighed, while the volume is found by measuring the volume of water required to fill the excavated hole. A thin flexible membrane is fitted in the excavated hole and the calibrated rubber-balloon apparatus is then fitted over the hole and filled with water. The volume indicator of the apparatus is then used to find the volume of the hole as seen in Figure 11.

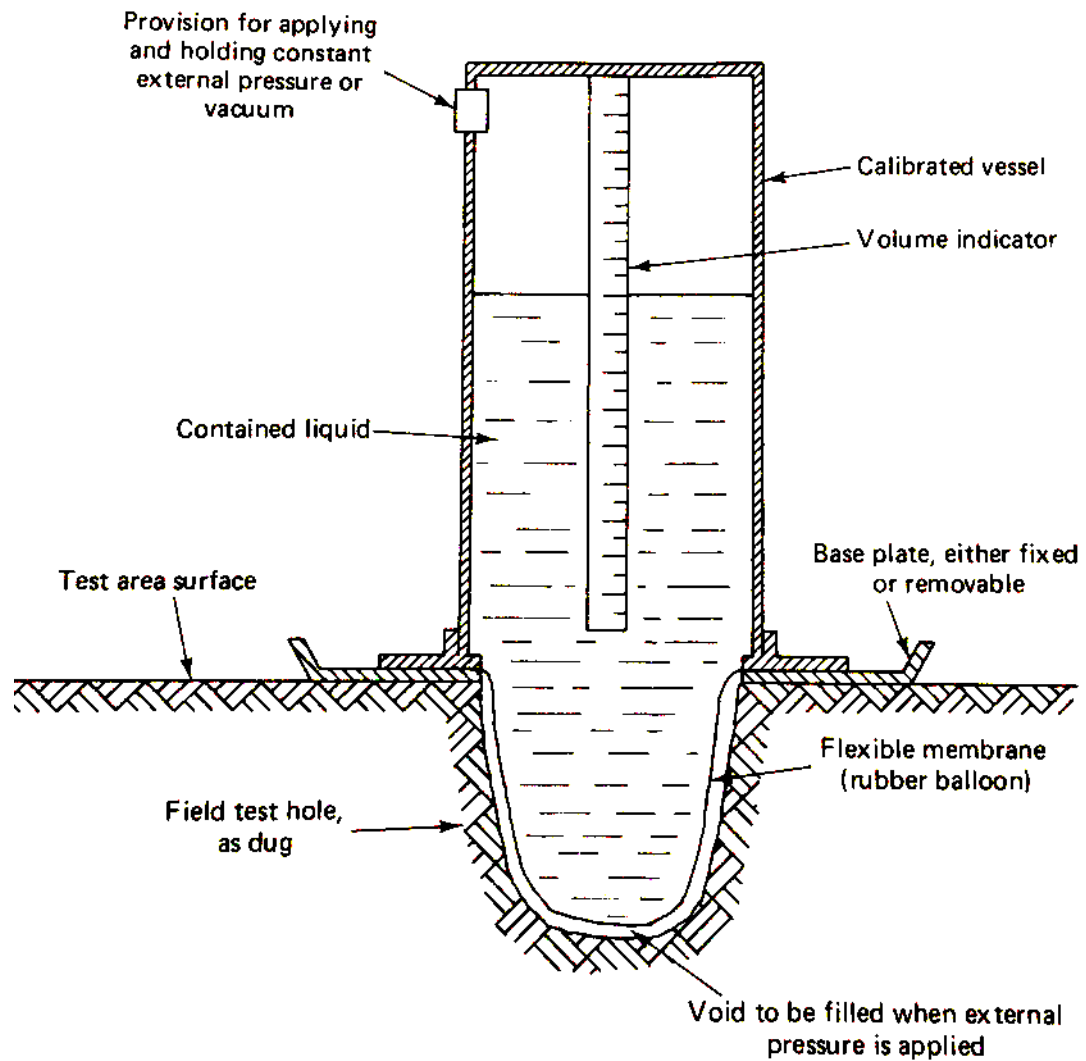

Figure 11: Schematic drawing of calibrated Vessel indicating principle (Liu and Evett, 2000).

The main advantage of the rubber-balloon method is that it has been used for decades with success. The disadvantage of the rubber-balloon test method is that the balloon is prone to bursting on jagged aggregates such as granular material. This compromises the test and test hole as it becomes saturated. The test accuracy is also dependent on the experience of the operator which can prove to be problematic.

2.3.4 Nuclear Density Gauge Review

The NDG is the most widely used method to determine in-situ unit weight and moisture content by DOT's (Rathje, 2006). The NDG functions by emitting gamma radiation into the material to be tested through a drop down rod inserted into the compacted material. Detectors in the device read the reflected gamma radiation to determine its wet density (Nazzal, 2014). Denser materials contain more electrons with which the photons of the gamma radiation interact; therefore, they reflect a lower number of photons back to the detectors (Nazzal, 2014). The number of detected photons is used to calculate the density of the tested material based on calibrated relationships.

The NDG also can measure the moisture content of compacted soil as well. The NDG contains a separate americium / beryllium high-energy source and a thermal neutron detector. The high-energy neutrons are retarded as they collide with hydrogen atoms present in moist compacted material. The thermal neutron detector counts the retarded neutrons. This count is proportional to the soil's moisture content. The gauge calculates the moisture content, subtracts it from the soil's in-place wet density, and reports the soil's dry density.

The NDG can be utilized in two different modes, both backscatter and direct transmission mode. The radiation source is placed within the soil layer being tested and radiation then travels through the soil back to the detectors located on the bottom the NDG in direct transmission. The radiation source emits radiation into the soil layer from the surface where it then reflects back to the detectors in back scatter mode. Figure 12 depicts how the NDG operates in both backscatter and direct transmission modes.

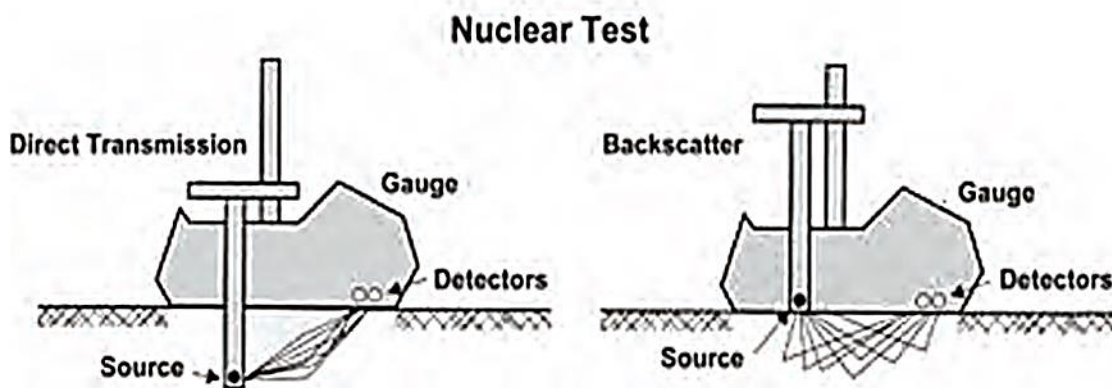

Figure 12: The NDG operation in both backscatter and direct transmission (Nazzal, 2014).

According to Rathje (2006) the neutrons used to measure water content will eventually reach thermalization, which means farther collisions with hydrogen atoms will not slow down the neutrons. This will result in lower moisture content reading of compacted fills. It was also noted that the NDG might be affected by the chemical composition of the soil tested. This is especially significant when measuring the moisture content of recycled pavement materials commonly used today, where hydrated water molecules are present in the cement (Nazzal, 2014). Therefore, it is not recommended to be used in recycled pavement materials.

Rathje (2006) also states that the NDG requires an initial calibration before each day of use but does not require a soil specific calibration. The calibration uses a reference block and is quick and simple (AASHTO, 2015e). The NDG advantage over other traditional density measurement devices previously discussed such as the sand cone or rubber-balloon method is that test can be conducted rapidly. The holes created when the NDG is used in direct transmission is also much smaller than the excavated holes created using other methods. This decreases the disturbance of compacted layers and results in a more uniform compacted fill.

The main disadvantage to the NDG is also what makes it unique among density measurement devices in that it uses radiation. Due to the potential health and environmental risks associated with using radiation, the Nuclear Regulatory Commission (NRC) requires strict controls over NDG devices. This increases the cost to own and operated the device (Rathje, 2006). Many state agencies now are willing to move to new alternatives to the NDG.

It has become a challenge of many researchers to find a suitable replacement for the NDG. Recent studies (Ernest et. al, 2013) have worked to find a suitable replacement for the NDG with a wide range of new technologies in development and some are being implemented by state agencies making it clear that replacements are near. The Engineering Research and Development Center (ERDC) began a broad ranging study of these new technologies to determine density. These will be discussed in the next section along with summaries of newly developed devices to measure compaction of granular materials (Ernest et. al, 2013).

2.4 Alternative Density-Based Measurement Test Methods

The NCHRP conducted a study of non-nuclear methods for compaction control of unbound materials (Nazzal, 2014). As part of this study, they collected information from 41 DOT's and Canada on various types of non-nuclear methods for compaction testing of unbounded materials that have been evaluated or implemented. The study also summarized detailed reviews of recent technologies used to measure both in-situ density or the stiffness and strength modulus of unbound soils. The study divides the new technologies into two separate categories: non-nuclear methods for density measurements of unbound materials and non-nuclear methods for in situ stiffness and/or strength of unbound materials. This study forms the basis for the following discussion. Section 2.4 summarizes density-based measurement test methods and Section 2.5 summarizes stiffness / strength measurement test methods.

The study highlights that the implementation of new non-nuclear testing methods for density measurements would not require significant changes to existing specifications because density-based specifications already exist and have been used for decades by the SDDOT. The integration of new testing methods, which involve stiffness and strength however, would require the development of new standard specifications for these new testing methods.

2.4.1 Moisture Density Indicator

The Moisture Density Indicator (MDI) consists of four metal spike probes encased in a single probe head. The probe head is connected by a coaxial cable to a Time Domain Reflectometry (TDR) pulse generator. TDR analysis is conducted with the transmission of an impulse into the system and the subsequent observation of energy reflected back to the system. The generator is connected to a personal digital assistant (PDA). During a given test, the spikes are driven into the ground in a triangular fashion with a single probe in the center as shown in Figure 13. The center probe acts as a central conductor while the outside probes act as a theoretical coaxial cable. The probes send out electromagnetic waves into the surrounding in-situ soil, which acts as an insulator. The waves then reflect off the soil and return to the probes. The PDA contains software to determine the density and moisture content of the surrounding compacted soil. The device does not currently have an AASHTO standard designation.

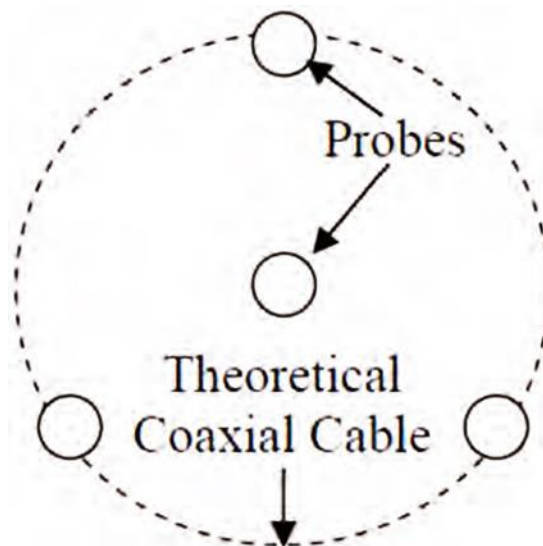

Figure 13: Probe pattern for the MDI (Nazzal, 2014).

The MDI has two operation modes, the first being the one-step mode which measures bulk electrical conductivity and dielectric constant values together for a given soil used to determine the dry density and moisture content. The two-step mode first measures the dielectric constant values of in-situ soil and a soil sample excavated from the field and compacted in a standard laboratory compaction mold. The density of the in-situ soil is then determined by comparing the dielectric constants and the known density of the soil in the compacted mold (Nazzal, 2014). Ernest (2013) evaluated non-nuclear alternatives to the NDG and found that the Soil Density Indicator was the best electrical device overall and had the best combination of accuracy and precision when compared to the NDG. Calibration of the MDI requires determining constants for specific soils which is performed by measuring the dielectric constants for several samples compacted using standard laboratory compaction tests at varying moisture contents. The obtained data are plotted with these constants versus moisture content to determine calibration constants of a specific soil (Nazzal, 2014).

The MDI has advantages in that studies have indicated that the device is repeatable. Rathje et al. (2006) reported a coefficient of variation measurements was less than 15 percent. They also stated that moisture content measurements were very close to those obtained using the oven dry method. The MDI is also much safer than the NDG as it does not use radiation, which also reduces operational cost of the device. Jackson (2007) indicated problems driving and removing the spikes and reported test

times of more than 15 minutes. It was also reported that spikes could bend in base coarse materials. They also reported that although moisture content measurements obtained by the MDI were closely related to NDG measurements, the dry density measurements were consistently lower for the MDI when compared to those of the NDG. Another disadvantage to the MDI is the need to calibrate the MDI for varying materials when using the two-step mode.

2.4.2 Electric Density Gauge

The Electric Density Gauge (EDG) uses high frequency radio waves to measure the density and moisture content of soils (Nazzal, 2014). The EDG device and calibration procedure has many similarities when compared to the MDI. The EDG uses four probes driven into the soil to measure the electrical dielectric properties similarly to the MDI which uses three. Constants required by the device need to be calibrated by measuring the soil compacted in a standard laboratory compaction test mold at varying moisture contents for compacted soil of interest. The EDG determines the dry density and moisture content of the tested material through a transmitted radio frequency. The EDG test is conducted in accordance with an ASTM D 7830 (ASTM, 2016c) standard but does not currently have an AASHTO standard designation.

The EDG shares the same advantages and disadvantages with the MDI. The EDG also does not use nuclear radiation, making it a much safer option over the NDG. The EDG calibration process was found to be complex and time consuming and spikes were found to be difficult to drive into and remove from granular material (Rathje, 2006 and Brown, 2007). The numerous parts associated with the EDG were also found to be cumbersome in the field resulting in additional time to complete the tests. There was no general consensus among studies of reliability and accuracy of measurements when using the EDG (Nazzal, 2014).

2.4.3 Soil Density Gauge

The Soil Density Gauge (SDG) is a self-contained unit that uses Electromagnetic Impedance Spectroscopy (EIS) to measure the density and moisture content of various unbound materials (Nazzal, 2014). Much like the two previous devices for determining density, the SDG measures the dielectric properties to soil to determine the density and moisture content. A central ring generates a radio

frequency ranged electromagnetic field into the soil and an outer ring receives and measures the dielectric properties (Nazzal, 2014). The SDG also requires calibration for specific compacted soils of interest. This is completed in a similar fashion as the MDI and EDG. Soil samples are compacted in a standard laboratory compaction mold at varying moisture contents and the SDG is then used to measure the dielectric properties. The field testing of unbound materials with the SDG requires five tests to obtain a density and moisture measurement (Nazzal, 2014). The standard method for use of the SDG is ASTM D 7830 (ASTM, 2014). There currently is no AASHTO standard designation for this test method.

Previous studies have indicated that the SDG density and moisture content measurements were repeatable and close to measurements made by the NDG (Nazzal, 2014). The device does not involve driving spikes which increases the ease of use of the SDG. However, the SDG requires five separate tests to obtain a single density and moisture reading making testing more time consuming. The main advantage of the SDG is that it can provide accurate and repeatable moisture and density measurements if the operators of the SDG have extensive knowledge of this device (Ernest et al., 2013). Ernest et al. (2013) evaluated non-nuclear alternatives to the NDG and found that the Soil Density Indicator was the most practical electrical device and had the highest ranked combination of accuracy and precision when compared to the NDG.

2.5 Stiffness / Strength Measurement Tests Methods

It has been previously discussed that moisture density relations are currently used extensively by DOT's for compaction quality control. However, these methods do not directly reflect the engineering properties of granular unbound materials required to establish optimum pavement performance. The main properties used to specify the degree of compaction in the design process are stiffness and strength. These properties are considered measurements of the soil layers stability and resistance to deformation under load (Nazzal, 2014). It was stated by White et al. (2007) that even small variations in density can have relatively large effects on stiffness and strength. Therefore, errors introduced during traditional density-based compaction quality control can produce potential significant differences in the performance of compacted unbound granular material.

A shift from empirical to mechanistic empirical pavement design procedures has resulted in an increased interest in compaction control specifications that rely on stiffness and strength measurements. This section summarizes stiffness and strength measurement tests methods that have been developed to measure these properties for in-situ compacted unbound granular material. The NCHRP study forms the basis for these methods.

2.5.1 Clegg Hammer

The Clegg Hammer (CH) has been utilized since the 1960s and was developed in Australia to measure the stiffness of in-situ soils. The device consists of a flat-end hammer within a guide tube. The basic operation for the CH is to measure the deceleration of a free-falling mass from a set height onto a soil surface (Nazzal, 2014). There are several hammer weights available for use. The standard method for the use of the CH is ASTM D 5874-16 (ASTM, 2016d) and there currently is no AASHTO standard designation. An accelerometer attached to the hammer generates a Clegg Impact Value (CIV) upon impact. A target CIV must first be established by compacting a soil of interest in a modified laboratory compaction mold at varying moisture contents. The CH is then used to test the soil at these varying moisture contents to find the maximum CIV, which becomes the target CIV. The process can be time consuming for field inspection. CIV values can be related to the elastic modulus based on elastic plate bearing theory. An advantage of the CH is that it is simple to use and requires minimal training. Farrag (2005) evaluated the CH found considerable variation in the results when the CH was used on granular unbound materials and was not recommend in these soils.

2.5.2 GeoGauge

The GeoGauge device generates a very small dynamic force at varying frequencies to determine the stiffness of a given in-situ soil. These frequencies are smaller than that of operational equipment and other vibration interference. The GeoGauge rests on the soil surface on a ring-shaped foot and weighs approximately 22-lbs (10-kg). The force applied to the soil is measured across a flexible plate by two velocity sensors (Nazzal, 2014). The GeoGauge can be utilized to determine dry density of soils but research has indicated poor correlations (Nazzal, 2014).

The GeoGauge offers quick measurement of the in-situ stiffness of compacted soil (less than 2 minutes), which provides an advantage over other devices. The GeoGauge is also simple to use and requires minimal training (Nazzal, 2014). There is also no current AASHTO standard for the GeoGauge. The GeoGauge was evaluated by Farrag (2005) and was found to produce rapid results but was sensitive to seating procedure and had poor correlations in granular materials, in that it is difficult to seat the device in granular material. Another disadvantage of the GeoGauge is that the small applied loads used during a test do not represent stress levels encountered as a result of traffic loads and therefore require correction.

2.5.3 Light Weight Deflectometer

The LWD uses the release of a falling weight from a standard height onto a loading plate (Nazzal, 2014). According to Nazzal (2014) the central deflection of the loading plate upon impact of the falling weight is measured using two methods. The first method integrates the velocity measurements obtained from a velocity transducer to find LWD modulus. The second method uses double integration of the acceleration data obtained from the accelerometer to determine the LWD modulus. Several factors may influence the LWD modulus such as the falling mass, drop height, plate size, plate contact stress, and load transducer (White et al. 2004). The LWD modulus is comparable to the surface modulus of layered system having homogeneous properties, assuming constant loading on an elastic half space (Nazzal, 2014). The test currently does not have a standard AASHTO method for granular materials.

The main advantage of the LWD was that it has a relatively quick setup and test time. Indiana and Minnesota DOT's have developed standard test procedures for the LWD. It was also noted that previous research of the LWD had indicated more accurate testing of a larger range of soils such as granular unbound materials (Nazzal, 2014). A disadvantage of the LWD is its low repeatability. Nazzal (2003) reported poor repeatability when testing weak cohesive materials or layers with uneven surfaces.

2.5.4 Dynamic Cone Penetrometer

The DCP has been in use since the 1970s and has been used internationally to evaluate in-situ soil layers. The device consists of a rod, drop weight, and a cone penetrator. The basic operation

involves dropping a weight from a standard height of 575-mm and recording the number of blows versus depth. The Penetration Rate (PR) or the Penetration Index Value (PIV) is then calculated in millimeters or inches per blow. Materials with small rates of penetration will have better compaction. The first two blows are referred to as the SEAT and evaluate the top of a compacted layer where there is often less confinement of compacted material. The final 3 blows when conducting a test measure the PR of the compacted soil deeper in the layer. The equations used to calculate the PIV and SEAT are provided (2.1 and 2.2).

$$\text{PIV} = \frac{A - B}{3} \quad (2.1)$$

Where,

PIV = Penetration Index Value (mm/blow)

A = Penetration reading after 5 blows (mm)

B = Penetration reading after 2 blows (mm)

$$\text{SEAT} = A - B \quad (2.2)$$

Where,

A = Penetration reading after 2 initial blows (mm)

B = Penetration reading before 2 initial blows (mm)

The test can be performed in accordance with the ASTM D 6951 (ASTM, 2016e), however, there is currently no AASHTO standard test method. The DCP can be used to conduct compaction quality control on recycled materials as well as virgin base and subbase materials making it more versatile than the NDG. The research has developed supplemental specifications and a procedure for utilizing the DCP in granular compaction quality control along with field data worksheets. These documents are presented in Appendix A. The DCP schematic is shown here in Figure 14.

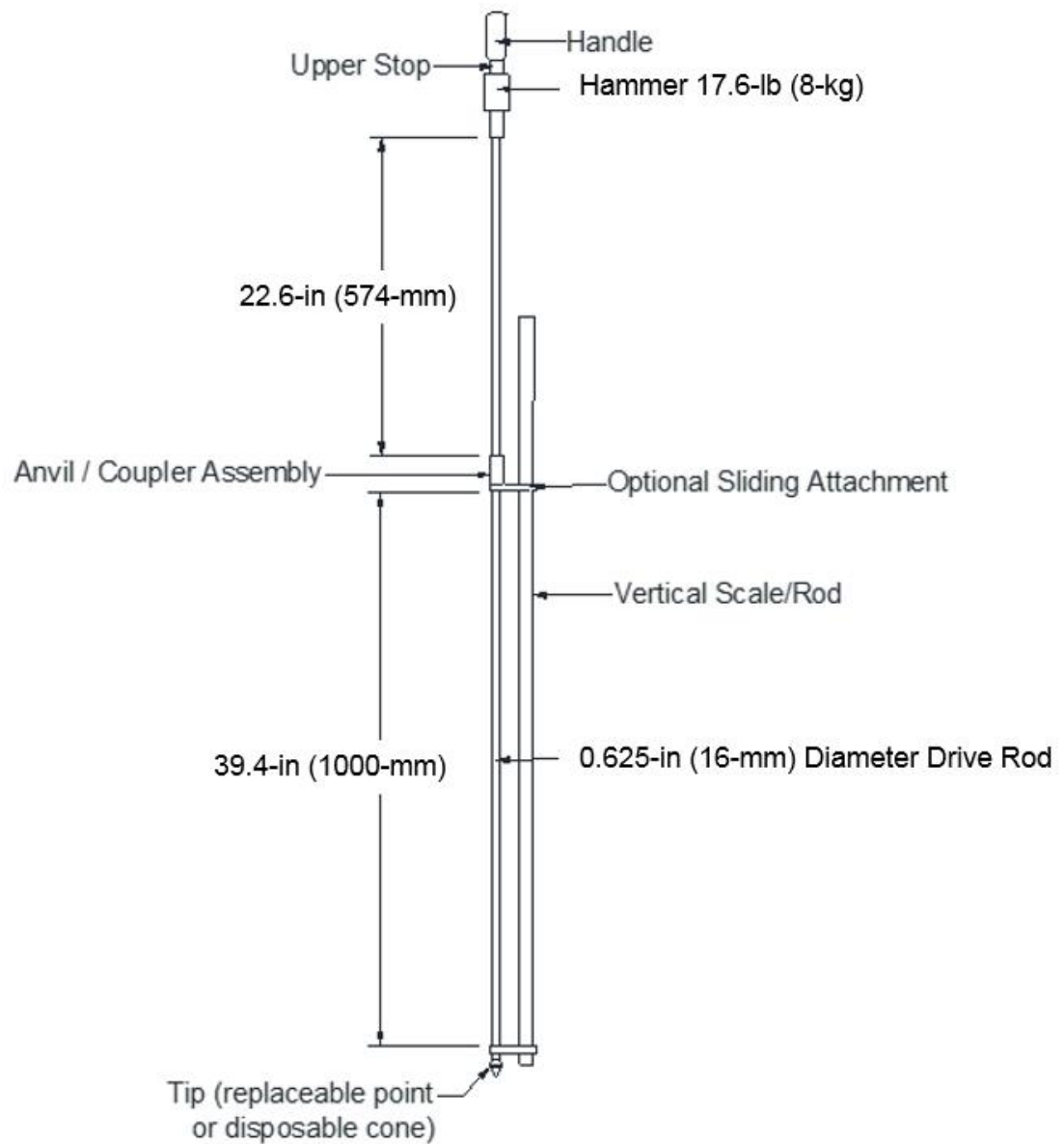

Figure 14: DCP schematic.

Amini (2003) summarized that the DCP can be correlated with various modulus and strength based values. Ese et al (1995) stated that the DCP could estimate the CBR for aggregate base course. Ese et al (1995) developed Equation 2.3 for correlating the PIV to the CBR of an aggregate base course. George and Uddin (2000) developed a simple relation between the PIV and the resilience modulus (M_R) of both fine grained (Equation 2.4) and coarse grained soils (Equation 2.5).

$$\log(\text{CBR}) = 2.44 - 1.07 \log(\text{PIV}) \quad (2.3)$$

$$M_R = 532.1 * \text{PIV}^{-0.492} \quad (2.4)$$

$$M_R = 235.3 * \text{PIV}^{-0.475} \quad (2.5)$$

The device has been field evaluated by Farrag (2005) and was found to be economical and simple to use with minimal training requirements. Farrag (2005) also showed that the DCP produced better results in silty-clay soils than in other soils. Dai and Kremer (2006) indicated that the DCP test is repeatable and the results were considered accurate. The only reported limitation to the DCP found in the literature was that it should be limited to use in materials with a maximum particle size of 2 inches (Nazzal, 2014).

According to the Standard Test Method for the Use of the DCP in Shallow Pavement Applications ASTM D 2487-11, the US Army Corps of Engineers has developed correlations between the PIV and the materials CBR. Equation 2.6 for a PIV in millimeters / blow and Equation 2.7 for a PIV in inches / blow present these correlations. These correlations could be used to estimate PIV target values for various granular materials by conducting laboratory CBR tests to determine the CBR at OMC.

$$\text{CBR} = \frac{292}{\text{PIV}^{1.12}} \quad (2.6)$$

$$\text{CBR} = \frac{292}{(\text{PIV} * 25.4)^{1.12}} \quad (2.7)$$

The Minnesota Department of Transportation (MnDOT) has recently implemented the use of the DCP for compaction quality control in their state and has been field testing the DCP as an acceptance tool for the compaction of pavement edge drain trenches since 1993 (Siekmeier et al, 1998). This included methods and specifications for the use of the DCP to conduct compaction quality control of granular subbase and base course and full depth reclamation. MnDOT also has published a User Guide for DCP, which it uses as a test procedure for their operations. MnDOT also uses PIV values which they refer to as the DCP Penetration Index (DPI) that measures the rate of penetration per blow (MnDOT, 2016). MnDOT uses a correlation between the PIV or DPI and the modulus of the soil to develop target PIVs or DPIs. The correlation is presented in Equation 2.8. The correlation was derived

from a South African research organization, Transportek (Lockwood et al., 1992) (Siekmeier et al., 2009).

$$E_{PIV} = 10^{3.04758 - [1.06166 \log(PIV)]} \quad (2.8)$$

MnDOT used this modulus correlation to develop target PIV for the DCP. The moisture content and the soil type have a significant influence on the DCP PR (Siekmeier et al., 2009). Therefore, the MnDOT developed a table of target values based on the in-situ moisture content and a mechanistic-based description of soil type. This table of target values is presented in Table 2. The Grading Number (GN) is calculated from the sieve analysis information for the material tested. The equation for calculating the GN is presented in Equation 2.9.

Table 2: Table of target PIV and Seating requirements.

Grading Number	MC (%)	Maximum Allowable Seating (mm) *	Maximum Allowable PIV (mm/blow)	Grading Number	MC (%)	Maximum Allowable Seating (mm) *	Maximum Allowable PIV (mm/blow)
3.1 – 3.5	< 5.0	40	10	4.6 – 5.0	< 5.0	65	15
	5.0 – 8.0	40	12		5.0 – 8.0	75	19
	> 8.0	40	16		> 8.0	85	23
3.6 – 4.0	< 5.0	40	10	5.1 – 5.5	< 5.0	85	17
	5.0 – 8.0	45	15		5.0 – 8.0	95	21
	> 8.0	55	19		> 8.0	105	25
4.1 – 4.5	< 5.0	50	13	5.6 – 6.0	< 5.0	100	19
	5.0 – 8.0	60	17		5.0 – 8.0	115	24
	> 8.0	70	21		> 8.0	125	28

$$GN = \frac{1'' + \frac{3}{4}'' + \frac{3}{8}'' + \#4 + \#10 + \#40 + \#200}{100}$$

(2.9)

Where,

Sieve numbers = percent passing each sieve

2.6 Device Cost

Table 3 contains the estimated device cost for both density-based devices and stiffness / strength based devices previously discussed. These estimates were summarized in the NCHRP study (Nazza, 2014). These cost estimates are for the devices only. The most expensive device was the CH and the least expensive was the DCP.

Table 3: Cost estimates for devices summarized.

Measurement Method	Device	Estimated Device Cost
Density-Based Devices	Moisture Density Indicator (MDI)	≈ \$6,000
	Electrical Density Gauge (EDG)	≈ \$11,500
	Soil Density Gauge (SDG)	≈ \$10,000
	Nuclear Density Gauge (NDG)	≈ \$6600
Stiffness / Strength Based Devices	Clegg Hammer (CH)	Device ≈ \$3,000, Complete System ≈ \$20,000
	GeoGauge	≈ \$5,500
	Light Weight Deflectometer (LWD)	Varies among manufactures. Humboldt Deluxe Model HD-4129.3F ≈ \$7,285
	Dynamic Cone Penetrometer (DCP)	≈ \$1,500

2.7 Intelligent Compaction

IC is a compaction technology used for the compaction testing of various materials including soils, aggregates, and asphalt mixtures. The system is attached to construction compaction equipment and typically uses a Real-Time Kinematic (RTK), Global Positioning Systems (GPS), a roller-integrated measurement system (normally accelerometer-based), feedback controls, and onboard real-time display of all IC measurements (Chang et. al, 2011). This type of compaction quality control has been used in Europe since the 1970's and about 80 percent of all compaction rollers sold in Europe have some type of continuous compaction control system installed (Zambrano et. al, 2006). However, interest in IC in the United States has only become apparent in recent years. These systems main advantage are that they have the ability to make the requirements for field spot testing and laboratory test unnecessary (Zambrano et. al, 2006).

Briaud and Seo (2003) compiled a list of IC research needs. The list included the need to demonstrate IC as a more effective method of compaction verification over other conventional compaction verification methods. Also on the list was a study of effective depth of compaction and a study of draft standard specifications and test methods. Most of the researcher's needs have currently been met and many states are now field testing IC systems. (Chang et. al, 2011) reported the results of sixteen field demonstrations performed over a three-year span between multiple states including Minnesota and North Dakota. The goals of the demonstrations were to develop an experienced and knowledgeable IC expertise base within DOT's, assist in developing quality control specifications for compaction of roadway materials, and identify and prioritize ongoing research needs for IC equipment and data analysis.

In 2009, field studies in Springville, NY evaluated the Caterpillar CS683 and the Bomag BW213-DH IC rollers comparing the IC measurement values with various in-situ point measurement values. Various point measurement devices used were the LWD, FWD, DCP, NDG, and SDG. Weak correlations were found between IC measurements and the various point measurements when stiffness / strength devices were used (White, 2009). IC measurements generally correlated better with modulus/stiffness measurements and CBR point measurement than did dry density point measurements (White, 2009). The results of this study provided new information that demonstrated the potential advantages of implementing IC roller operations and various in-situ testing methods into earthwork construction quality control practice (White, 2009).

2.8 Current SDDOT Practices

The following section summarizes the SDDOT's current compaction practices. This includes materials encountered, methods of base course and subbase compaction quality control, and recycled and salvage material compaction quality control. The current SDDOT Standard Specifications for Roads and Bridges SDDOT (2015a) and interviews with selected members of the SDDOT Technical Panel (SDDOT, 2016) were utilized as the basis for this section.

2.8.1 Materials Encountered and Gradation Requirements

The requirements for acceptance of Aggregates for granular bases are defined in Sections 882.1 to 882.3 of the South Dakota Department of Transportation Standard Specifications (SDDOT, 2015a). Specific requirements for grain size distribution are provided in Table 4. The SDDOT use SD 103 to classify materials according to the AASHTO M 145 classification system.

Table 4: SDDOT Specific Requirements for Aggregate Acceptance (SDDOT, 2015a).

Requirements	Subbase	Gravel Cushion	Aggregate Base Course	Limestone Ledge Rock (Base Course)
Sieve	Percent Passing			
6 inch				
2 inch	100			
1 inch	70 - 100	100	100	100
3/4 inch		80 - 100	80 - 100	80 - 100
1/2 inch		68 - 91	68 - 91	68 - 90
# 4	30 - 70	46 - 70	46 - 70	42 - 70
# 8	22 - 62	34 - 58	34 - 58	29 - 53
# 40	10 - 35.0	13 - 35	13 - 35	10 - 28
# 200	0.0 - 15.0	3.0 - 12.0	3.0 - 12.0	3.0 - 12.0

Specific requirements for various milled, reclaimed and salvaged material are found in Section 884.2 of the South Dakota Department of Transportation Standard Specifications (SDDOT, 2015a). Reclaimed Asphalt Pavement (RAP) along with Salvaged materials such as subbase, base course, and gravel surfacing all have the same required specific grain size distribution requirements of 100 percent must pass the 1.5 inch sieve and 95-100 percent must pass the 1 inch sieve.

According to the SDDOT Minimum Sample and Test Requirements (MSTR), when quality tests are required by specification, one sample per 50,000 tons shall be submitted to the SDDOT's Laboratory for testing. Aggregate production from the same source used by one or more projects at the same time only require a single minimum test frequency for quality assurance. The sample size is specified as 120 pounds in 4 bags. Tests are not required for quantities less than 100 ton per day or 500 ton per project (SDDOT, 2015a).

2.8.2 Methods of Base Course and Subbase Compaction Quality Control

SDDOT's current methods for compaction control of various granular material is defined in Section 260.3 of the South Dakota Department of Transportation Standard Specifications (SDDOT, 2015a). Base Course material is to be compacted to 97 percent of maximum dry density. The maximum dry density is determined by the SD 104 Method 4 (SDDOT, 2015b) which has close relation to the

AASHTO T 272-15 (AASHTO, 2015c). This method is known as a one-point determination used for more rapid determination of target density when compared to the AASHTO T 180 (AASHTO, 2015c), which is the four-point equivalent. The method requires compacting a single point at approximately optimum moisture in a standard 6-in mold in similar manner to the AASHTO T 99 (AASHTO, 2015b). A wet density and moisture is determined for the single point and is entered into the family of compaction curves. The curve that is closest to the wet density and optimum moisture is then adopted as the family curve for that material. The corresponding dry density is then adopted as the target density for the material tested. The SDDOT currently requires a one-point determination for every in-place density tests conducted to establish an individual target density for each test. The one-point determination uses material from or adjacent to the hole for each in-place test. If the one-point moisture content deviates from optimum (for the curve selected) by more than 2 percentage points below or 1 percentage point above, a second one-point is required at or nearer to optimum and within the stated tolerance stated by the SD 104 (SDDOT, 2015b).

Prior to the first in-place density test, a single four-point determination of maximum dry density and optimum moisture is determined for the base course materials to be tested. The four-point determination is conducted in accordance with the SD 104 Method 3 (SDDOT, 2015b). A four-point determination is required to verify if the family of compaction curves is suitable for the material. Once a four-point determination of dry density and optimum moisture is determined, it is compared to the one-point determinations required for each in-place density. When the one-point determination deviates more than 3 pounds from the four-point results, another one-point determination is conducted. Similarly, if moisture in the one-point determination deviates more than 2 percentage points below or 1 percentage point above optimum moisture, another one-point (nearer to optimum moisture) or a new four-point determination should be conducted.

In-situ field density of base course and subbase is determined by one of the following methods:

- 1.) SD 105: Density of soils / Granular Material In-place by Sand-Cone Method (SDDOT, 2015c)
- 2.) SD 110: Density of Granular Material by Modified Sand-Cone Method for Thin Layers (SDDOT, 2015d)

3.) SD 114: Determination of In-place Density of Soils and Aggregates by Nuclear Method
(SDDOT, 2015e)

The most common test method for base course materials in South Dakota is SD 105 (SDDOT, 2015c). Each of SDDOT's four regions contains six NDG totaling 24 gauges in all (SDDOT, 2016). In-place density tests are conducted every mile, per lift, per roadbed surface just prior to application of prime or subsequent course according to the SDDOT MSTR (SDDOT, 2015a).

2.8.3 Methods of Recycled and Salvaged Compaction Quality Control

A growing practice of the SDDOT is recycling or reclamation of pavement surfaces, bases courses and subbases. Materials classified as recycled materials can be placed into a stockpile while materials classified as reclaim remain in place and are used to form the new road bed. FDR is defined by the processing and blending the asphalt mix and granular base material and placing, watering, shaping, and compacting the material to the typical section (SDDOT, 2015a). The materials are to meet the standard specifications of asphalt mix and granular base materials outlined in Section 884.3 of the South Dakota Department of Transportation Standard Specifications (SDDOT, 2015a). The FDR process is outlined in Section 280 of the SDDOT Standard Specifications, Section 280.B, and states that material is to be placed in a minimum of two lifts and lift thickness shall not exceed 4-in in depth (SDDOT, 2015a).

“Section 280.3.C. Compaction and Density Requirements” states that each compacted layer shall meet a minimum of 95 percent of the target dry density established by Method SD 219 (SDDOT, 2015f) and material shall have a minimum moisture content of 4 percent uniformly blended throughout the depth of the lift of material (SDDOT, 2015a).

Method SD 219 requires use of a test strip with a minimum length of 500 feet. Four tests sites are selected throughout the test strip (typically in the middle 300 feet). A NDG calibrated and standardized in accordance with SD 114 (2015e) is used to determine the wet density at each test location within the test trip. The test rod of the NDG is inserted into the material so that it is as close to the bottom of the lift as possible but not within 1 inch of the bottom of the layer. Once density is measured, a roller makes four passes over the test strip “one series”. After completion of four passes or

one series, the NDG is again used to measure wet density at each test location. The average wet density of each series is recorded on the DOT-28 test form. This process is repeated for each series until the increase in average wet density is less than 1.0-pcf. At this time, samples of the material directly below the four NDG test locations are immediately placed in an airtight container for moisture testing. SD 108, is an oven drying method used to determine the moisture content of the material (SDDOT, 2015g). The target dry density is then determined by averaging the four dry density measurements. A minimum of one test strip is performed for each lift. However, the field technician can require additional test strips when there is a significant change in aggregate type, weather conditions, or other controlling factors to check target density. The test strip becomes part of the constructed roadway upon completion of the work (SDDOT, 2015a).

In-place density determinations using Method SD 219 is performed using the NDG. These tests are conducted in the same manner as those previously discussed to determine dry density of the test strip. Moisture determination is conducted for each in-place density test using Method SD 108: Oven Drying Method and the dry density and percent compaction is subsequently calculated (SDDOT, 2015a).

3.0 DATA COLLECTION AND ANALYSIS

The SDDOT currently uses both four-point moisture density relations and one-point moisture density determinations when conducting granular compaction quality control. The one-point moisture density determinations are plotted on the Ohio Highway Department's Typical Moisture-Density Curves, Set C to obtain target density and OMC as previously discussed in Chapter 2. These curves were the third iteration of a family of compaction curves originally developed for a similar one-point method utilized by the Ohio Highway Department when working with cohesive soils. The SDDOT has since adopted this family of compaction curves and added additional interpolated compaction curves.

During typical granular base and subbase compaction quality control by the SDDOT, four-point moisture density relations are used to verify the use of the family of compaction curves. Then the one-point method described in Chapter 2 is utilized with the Ohio's Highway Department's Typical Moisture Density Curves Set C to determine target densities. The SDDOT wishes to know if this family of compaction curves is adequate for predicting target density and OMC values for base and subbase granular materials encountered in South Dakota.

3.1 Analysis Goals

The development of the Ohio Highway Department's Typical Moisture-Density Curves, Set C was documented in Section 2.3.1 and their use by the SDDOT was documented in Section 2.8.2. This chapter presents the analysis of SDDOT data used to evaluate the Ohio Highway Department's Typical Moisture Density Curves. This chapter also summarizes the results of a survey administered to other states DOT to learn more about other DOT's compaction practices. Information obtained from the analysis helped evaluate the following questions:

- Should the SDDOT continue to use the Ohio Highway Department's Typical Moisture Density Curves?
- Should new curves be used by the SDDOT?
- Should other methods other than those currently used by the SDDOT be utilized in determining target density of granular materials?

Therefore, the goal of the data analysis was to provide input that would support answers to these questions. It was first necessary to create a family of compaction curves based solely on four-point compaction data provided by the SDDOT. From these curves, a line of optimums was created allowing for an evaluation of the Ohio Highway Department's Typical Moisture Density Curves. The new curves were created using data provided by the SDDOT from laboratory moisture density relations of base course and subbase granular soils encountered in South Dakota. The line of optimums of these new compaction curves was then compared with the line of optimums of the Typical Moisture Density Curves, Set C. This provided a comparison of the differences between maximum dry unit weight and OMC of South Dakota base course and subbase granular material testing and the line of optimums of the Ohio Highway Department's Typical Moisture-Density Curves, Set C. The difference in the corresponding dry unit weight of the two lines of optimums were then statistically tested for differences. The magnitude of this difference could then be quantified.

Standard statistical modeling in engineering usually limits error rates at 5 to 10 percent. Therefore, a 95 percent prediction interval on the maximum dry unit weight and OMC of base course and subbase granular materials encountered in by the SDDOT was also developed. The prediction interval indicated a region in which 95 percent of all base course and subbase granular maximum dry unit weights and OMCs observed by the SDDOT would likely plot. This interval was constructed to provide evidence that would support the adequacy or inadequacy of using the Ohio Highway Department's Typical Moisture Density Curves. The interval could also provide evidence for the adequacy or inadequacy of any family of compaction curves for which a comparison is made. Lines of optimums that fall within this region may be more adequate when utilized for granular compaction quality control by the SDDOT.

3.2 Data Collection and Conditioning

The data used for the analysis was provided by the SDDOT and presented in Appendix B. The data consisted of records of both field and laboratory material testing data. Discarded data included data with unidentifiable errors and incomplete data as will be discussed. This resulting data set provided a

representation of actual SDDOT testing results and provided sampling of South Dakota granular materials.

The SDDOT provided data contained on the DOT-3, DOT-28, DOT-40, and DOT-41 forms from the years 2001 to 2016. The data forms provided are defined in Table 5 with examples of each form provided in Appendix B. The data was imported into a spreadsheet format for further analysis. The data fields were evaluated for use in the analysis which was then reviewed by the SDDOT. A table was created for the various data fields along with a general description, definitions, and if the data was deemed useful for this study. These tables can be found in Appendix B. The data was then conditioned by removing data not used in evaluating the goals of the research.

Table 5: Defined SDDOT Data Forms.

Data Form	Definition
DOT - 3	Sieve analysis data for all material types.
DOT - 28	Test strip data for recycled material.
DOT - 40	Moisture density relations for all materials.
DOT - 41	In-situ density testing data utilizing all testing methods.

Data pertaining to moisture density relations created from base course and subbase materials were of primary interest to this research. Moisture density relations are currently used by the SDDOT to verify the use of a family of compaction curves. Sieve analysis data may have provided general information indicating the drainage parameters of the various granular materials. This could have provided difference between field moisture contents before and after field compaction. Section 2.1.2 discusses the differences in moisture content between semi-draining and free-draining granular materials in further detail. However, given the format of the data, individual sieve analysis information could not be accurately related to individual moisture density relations. This made incorporating sieve analysis data into the analysis impossible. The nature of the test strip data did not allow for the development of compaction curves but may have provided a range of expected maximum density values for recycled materials encountered by the SDDOT. However, this information would be of little value to the current practices of the SDDOT. The SDDOT also does not use test strip data in junction with moisture density curves (SDDOT, 2015a). Therefore, the test strip data was not usable in the analysis.

Extensive data conditioning was conducted on the data pertaining to moisture density relations. The conditioning was necessary for several reasons. The research focused on granular materials and the provided data consisted of moisture density relations of all material types. Unrelated data types were deleted. The data did not contain wet and dry unit weight values and moisture contents for individual moisture density relations. However, the data contained all necessary information to calculate these values. To compare the data to the Ohio Highway Department's Typical Moisture Density Curves these

missing values were calculated. The data also contained duplicated moisture density relations. This is likely the result of the SDDOT's use of the same moisture density relations on various project sites when the same material is used (SDDOT, 2015a). The duplicated relations were removed to ensure there was no data skew. The data also contained various levels of data input errors. These errors consisted of unreasonable numbers contained in the data or missing data all together that made accurate determinations of wet and dry density or moisture content impossible. Data with more than 6 moisture density points were removed from the analysis as it would add unnecessary complications to the determination of maximum dry density and optimum moisture content. Careful consideration was also made regarding various comments provided for some of the data points provided. Comments that indicated voided or discarded test points were removed when possible. The technical panel also informed the research team that several moisture density relations were examples only and did not reflect real tests. These example tests were also removed. The conditioning prepared the data for comparison to the Ohio Highway Department's Typical Moisture Density Curves.

The data conditioning process was conducted using Microsoft Excel 2016 with the utilization of Visual Basic Application (VBA) Macro Programming. The moisture density relation data was imported to a filter table for preliminary data conditioning and the data header "Material Group" was used to filter out all data that did not consist of base course or subbase materials. Salvaged base course and subbase materials were also included. Sample identifiers such as headers "Main PCN", "Contract ID", "Sample ID", and "Test #" were used to organize data origins if necessary. All data not required to calculate the wet unit weight, dry unit weight, and moisture content for each point was removed from the data set. A VBA macro was used to search and eliminate duplicate data. The macro searched through the column labeled "Sequence Number" and removed entire rows of data which had two consecutive same numbers, indicating a duplicate. The conditioned data set was checked for quality by manually verifying 10 percent of the data set.

Wet and dry unit weights were calculated for 2506 moisture density points resulting in 474 moisture density compaction curves. The next step in the conditioning process was to determine the maximum dry unit weight and OMC of each laboratory moisture density relation. The data was then reorganized into groups of increasing maximum dry unit weight. The majority of the relations based on

four points. However, there were also several moisture density relations based on five points. According to SD 104 (SDDOT, 2015b), a smooth curve is to be drawn to connect points established by plotting the results of four or more test points. Therefore, to produce the large number of four point laboratory moisture density relations, a third degree polynomial was utilized to fit each curve for determination of the maximum dry unit weight. This would result in a coefficient of determination of 1.0 and the average coefficient of determination value for five point relations at 0.9575. Various statistics were calculated for each fitted curve including:

- Standard Error values for coefficients, and constants,
- Coefficient of Determination,
- F-statistic,
- Degrees of Freedom,
- Regression Sum of Squares, and
- Residual Sum of Squares.

The curve fitting coefficients were then used to calculate the maximum dry unit weight of each moisture density relation. From the coefficients, the local maximum of the fitted curve was calculated. The derivative of each equation with its calculated coefficients and moisture density points were used to determine the maximum point on the curve or peak. VBA macros were created to streamline processing.

The creation of a family of compaction curves was done by grouping laboratory moisture density relations data by two pcf increments of maximum dry unit weight. Two pcf was recommended by the AASHTO T 272-15 Family of Curves-One-Point Method (AASHTO, 2015f). Figure 15 shows all 2506 data points organized into increments of maximum dry unit weight ranging from 118-pcf to 144-pcf. The data points in each increment were then used to construct a curve representing each increment and create a line of optimums.

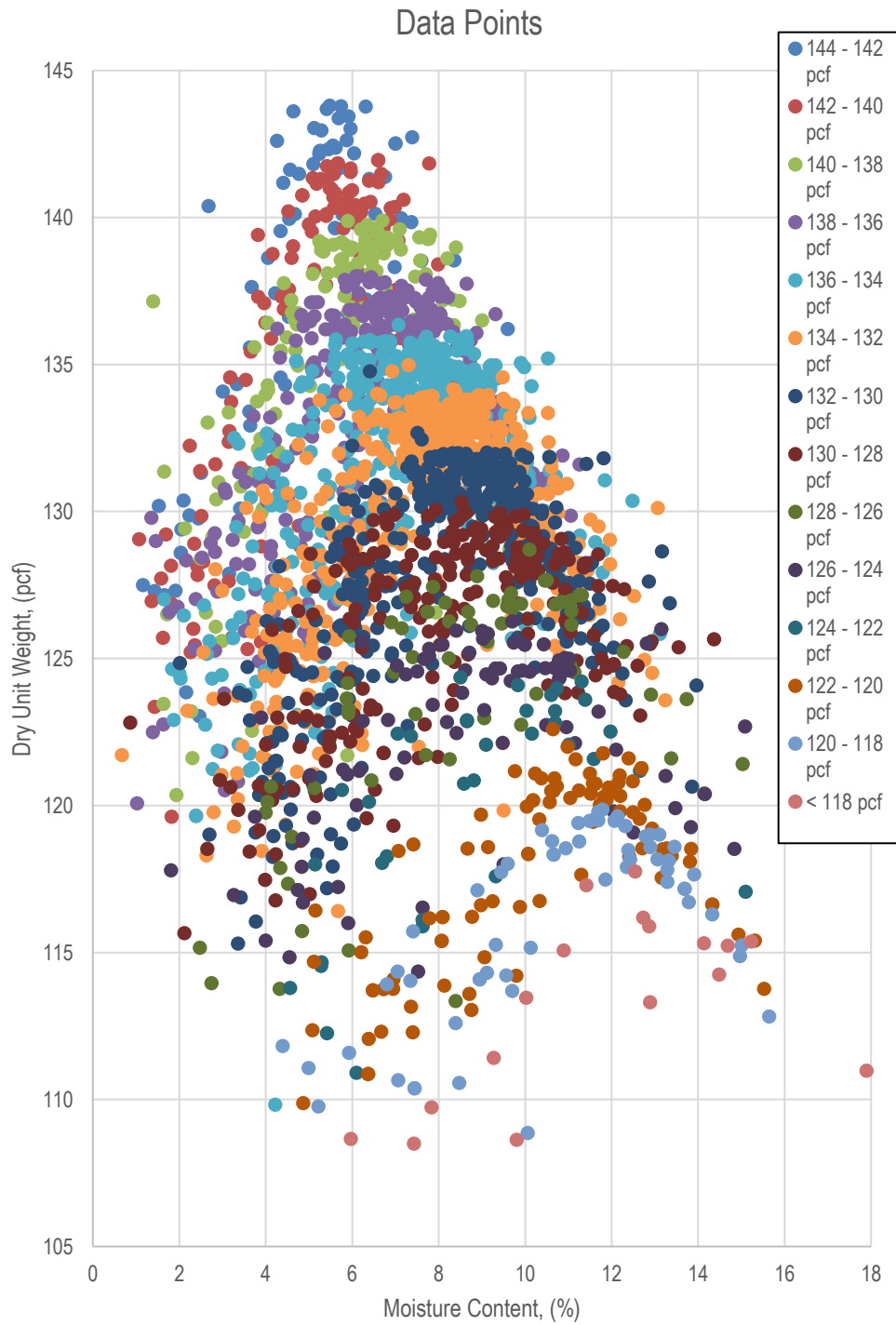

Figure 15: Plotted points used in the analysis.

Once separated into two pcf increments a third degree polynomial regression curve was used to construct a typical compaction curve for each increment of two pcf of dry unit weight. A third degree

polynomial was determined to have the most appropriate shape characteristics for fitting moisture density curves. The third-degree regression line also provided the smallest square error, indicating a good fit for the data points. The curves were fitted using the least square error method.

It was observed that the maximum point on each typical compaction curve was slightly below a large majority of the individual moisture density relations maximum values. This observation contributed to the data points on either side of the maximums skewing the fit of the curve downward as shown in Figure 16. The figure shows the fitted regression curve for moisture density relations with maximum dry unit weights between 128-pcf to 130-pcf. The orange points are the maximum dry unit weights of the various moisture density relations and the green point represents the average of all the maximum dry unit weight. If the vertex of each constructed typical curve was used as the target density and OMC, it may under estimate the required compaction. Therefore, if the constructed typical curves are to be used in compaction quality control, the fitted typical curves shall act as the boundaries between each incremental region. The average maximum dry unit weight and OMC for each bounded region was utilized as the target density and OMC for field testing.

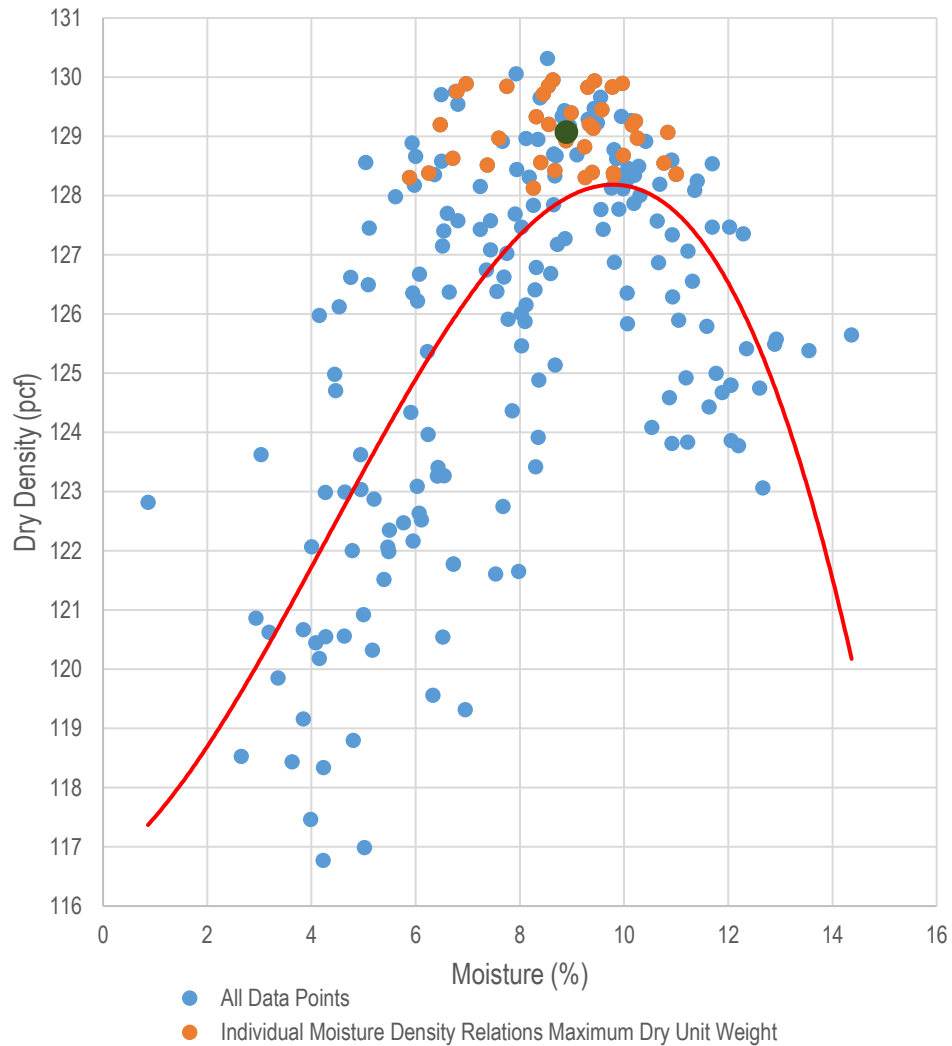

Figure 16: Observed skewed curve phenomenon.

The new family of compaction curves contained 14 typical compaction curves ranging in maximum dry unit weights between 118-pcf to 144-pcf and the OMC ranged from 6.52 percent to 13.86 percent. Each curve was designated a letter from A to N. As previously stated, the new curves were created using a third order polynomial in the following form with the following coefficients, $\gamma_d = aMC^3 + bMC^2 + cMC + d$. The coefficients for each curve are presented in Table 6. Table 7 summarizes the family of compaction curves developed in the analysis which includes the total number of data points, total number of moisture density relations, along with regression coefficients for each fitted curve. These curves were then plotted together to form a line of optimums to be compared to the

Ohio Highway Department's Typical Moisture Density Curves line of optimums. The new curves line of optimums is shown in red on Figure 17.

Table 6: Curve Coefficients.

Dry Unit Weight Curve		Curve Coefficients			
Designation	Dry Unit Weight Range, pcf	<i>a</i>	<i>b</i>	<i>c</i>	<i>d</i>
A	144-142	-0.0432	0.0125	5.3458	118.28
B	142-140	-0.0975	0.8383	1.5279	121.69
C	140-138	-0.0912	0.9955	-0.6101	125.21
D	138-136	-0.0546	0.6085	0.3052	122.28
E	136-134	-0.0182	0.0211	3.2200	115.85
F	134-132	-0.0291	0.3078	1.3122	116.58
G	132-130	-0.0190	0.1073	2.8738	109.52
H	130-128	-0.0182	0.2360	0.6080	116.68
I	128-126	-0.0063	-0.0573	3.1698	106.51
J	126-124	-0.0120	0.1615	0.5673	114.41
K	124-122	-0.0158	0.2058	1.2603	105.23
L	122-120	-0.0457	1.1763	-8.4413	131.32
M	120-118	-0.0496	1.3462	-10.438	135.94
N	< 118	-0.0192	0.5216	-3.4001	113.58

Table 7: Summary of new family of compaction curves.

Constructed Family of Compaction Curves Data Summary								
Maximum Dry Unit Weight Range	Curve Letter	Maximum Dry Unit Weight of Fitted Curve	Optimum Moisture Content of Fitted Curve	Average Maximum Unit Weight of Individual Moisture Density Relations	Average Optimum Moisture Content of Individual Moisture Density Relations	Number of Plotted Data Points	Number of Moisture Density Relations	Regression Coefficient of Fitted Curve
142 - 144	A	141.7	6.52	143.1	5.89	78	15	0.7342
140 - 142	B	140.3	6.53	141.1	5.98	128	25	0.7494
138 - 140	C	138.4	6.96	139.0	6.36	145	28	0.6023
136 - 138	D	135.8	7.67	136.9	7.13	306	59	0.5564
134 - 136	E	133.6	8.08	135.0	7.51	409	79	0.4641
132 - 134	F	132.1	8.77	133.1	8.18	454	88	0.5394
130 - 132	G	130.3	9.23	131.1	8.7	400	76	0.6097
128 - 130	H	128.2	9.78	129.1	8.89	220	40	0.4934
126 - 128	I	126.2	10.27	127.0	9.35	66	12	0.5905
124 - 126	J	124.3	10.48	125.1	9.5	86	15	0.417
122 - 124	K	123.0	11.08	123.1	10.18	34	6	0.6198
120 - 122	L	120.4	12.05	120.8	11.56	100	17	0.7319
118 - 120	M	118.9	12.47	119.3	12.18	63	11	0.7227
< 118	N	115.6	13.86	116.4	13.5	17	3	0.7341
Average Regression Coefficient of Fitted Curves								0.6118
Total Data Points Plotted								2506
Total Moisture Density Relations Plotted								474

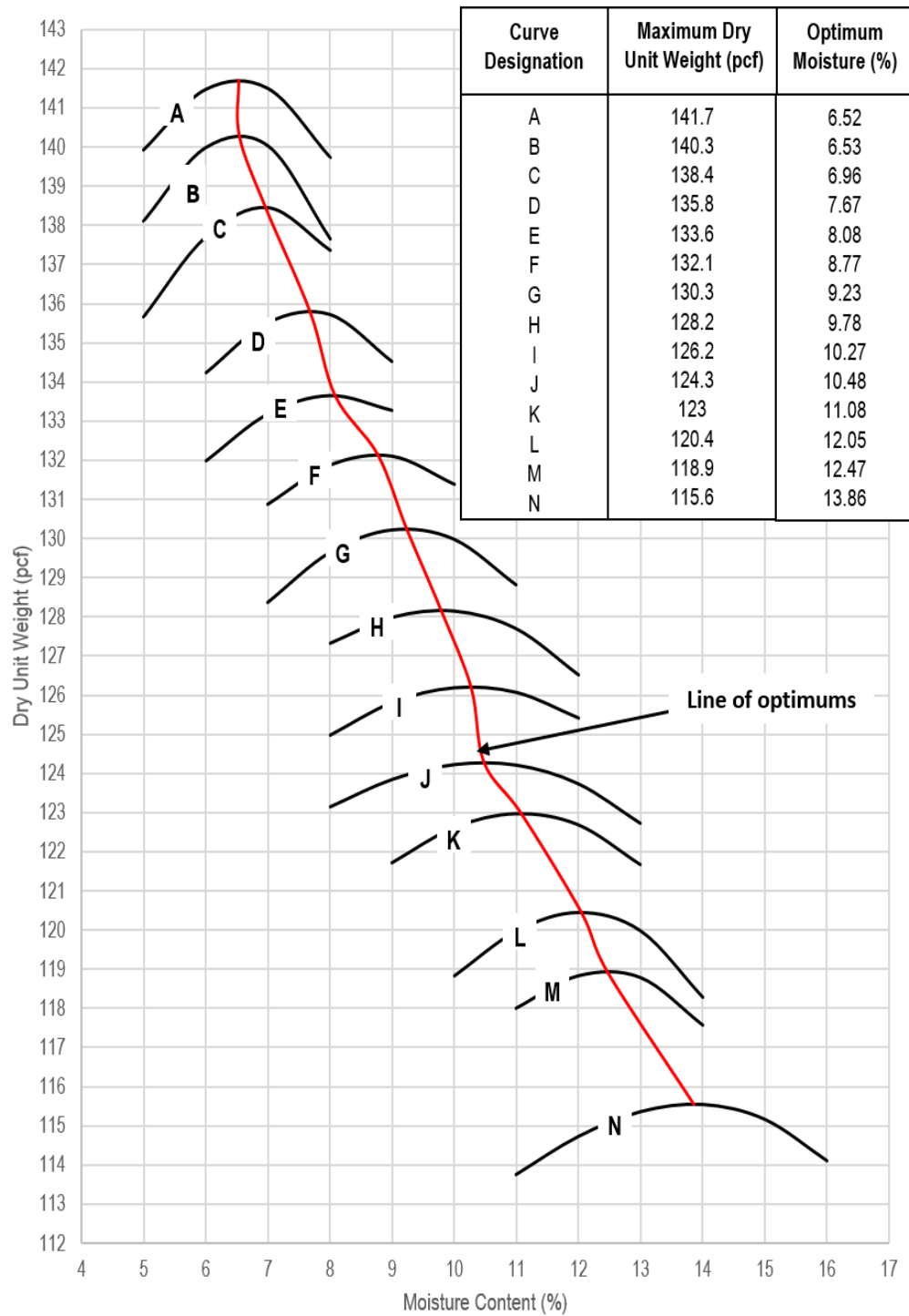

Figure 17: Line of optimums for new family of compaction curves (red line).

3.3 Lines of Optimums Comparison

The following section documents the statistical analysis used to analyze the relationship between the Ohio Highway Department's Typical Moisture Density Curves, base course, and subbase granular materials encountered by the SDDOT. This consisted of determining the magnitude of difference in the line of optimums of the Ohio Highway Department's Typical Moisture-Density Curves and the line of optimums determined by base course and subbase granular materials encountered by the SDDOT. Figure 18 shows the lines of optimums in the comparison. Although, there is a visual difference between the lines, they were statistically tested for significances and magnitude. From visual observation, the Ohio Highway Department's Moisture Density Curves may overestimate compaction. Section 3.4E of the SDDOT Materials Manual Method 104 states that if the maximum density determined by the Ohio Highway Department's Typical Moisture Density Curves deviates more than 3-pcf from the four-point range, the Region Materials Engineer shall be contacted(SDDOT, 2015b). Therefore, Figure 18 also presents dotted lines representing ± 3 -pcf from line of optimums created from four-point compaction data of SDDOT granular material. The line of optimums of the Ohio Highway Department's Typical Moisture Density Curves plots outside of this range from 125-pcf to 132.5-pcf and follows just slightly inside this range from 132.5-pcf to 141-pcf. This may indicate that the Ohio Highway Department's Typical Moisture Density Curves may not be adequate for SDDOT granular material.

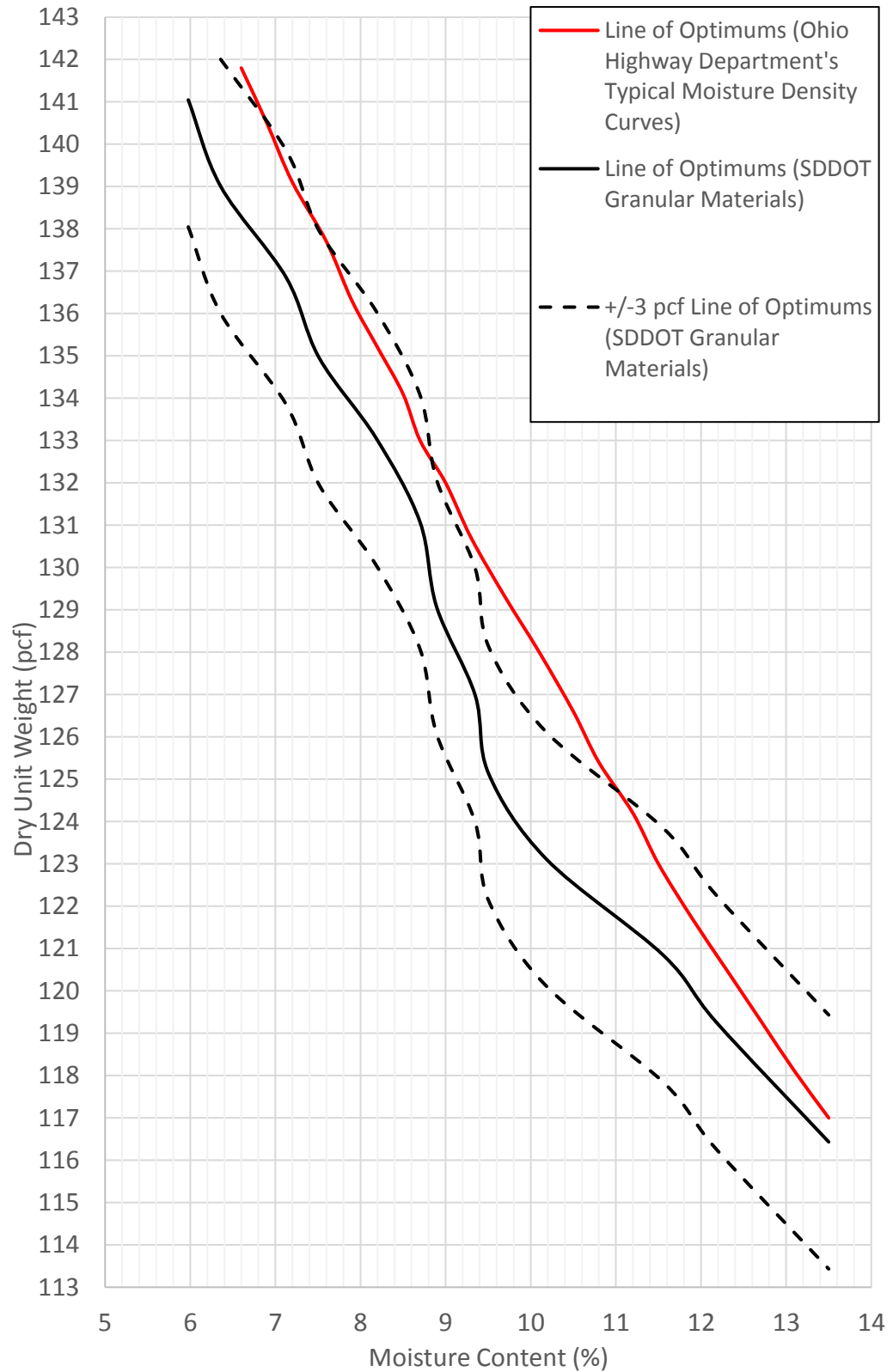

Figure 18: Lines of Optimums Used in Comparison Analysis.

A standard t-test was utilized to determine if there was a significant difference in the line of optimums of the Ohio Highway Department's Typical Moisture-Density Curves and the line of optimums of the newly created curves. A t-test is a statistical hypothesis test used to determine if two sets of data are significantly different from each other. Dry unit weights on each line of optimums were obtained at randomly selected moisture contents. The difference in maximum dry unit weight were averaged and statistically compared to zero. The following hypotheses was used to test if the average difference, μ was significant.

$$H_0: \mu = 0$$

$$H_1: \mu \neq 0$$

The null hypothesis, H_0 stated that the average difference was not significantly different than zero at a 95 percent confidence level. The analysis was to disprove the null hypotheses by providing evidence that indicates a significant difference. Table 8 presents the moisture contents and dry unit weights sampled including the calculated difference in dry unit weight between the lines of optimums. Moisture contents sampled ranged from 7 to 13 percent. The observed difference in dry unit weight ranged from 1.0-pcf to 4.8-pcf. The mean difference was 2.8-pcf which was statistically proven to be different than zero at a 95 percent confidence level. The t-statistic was 6.38-pcf which was within the rejection region of ± 2.44 pcf. The test statistics are shown in Table 9.

Table 8: Samples used for lines of optimums comparison.

Predictor Values Moisture Content, %	Ohio Dry Density Line of Optimums (Maximum Dry Unit Weight, pcf)	SD Materials Line of Optimums (Maximum Dry Unit Weight, pcf)	Difference in Maximum Dry Unit Weight, (pcf)
7	140	137.2	2.8
8	136	133.6	2.4
9	132	128.8	3.2
10	128.4	123.6	4.8
11	124.9	121.7	3.2
12	121.8	119.6	2.2
13	118.5	117.5	1

Table 9: T-Test Statistics.

Test Statistics				
Mean Difference (pcf)	Sample Variance (pcf)	Number of Samples	T-Statistic (pcf)	Rejection Region (pcf)
2.8	1.34676025	7	6.38	±2.4469

The test had $n-1$ degrees of freedom and a 95 percent confidence level was selected. As previously stated, the calculated test statistic was within the determined rejection region. Therefore, the null hypotheses was rejected at a 95 percent confidence level. This indicates that on average, the line of optimums of the Ohio Highway Department's Typical Moisture Density Curves may be overestimating the level of compaction required for adequate levels of compaction by nearly three pcf. This would contribute to a 2 to 2.5 percent difference in maximum dry unit weight predictions. The results would require over compaction in the field in order to meet target densities determined by the currently used Ohio Highway Department's Typical Moisture Density Curves.

3.4 Determining Adequacy of Families of Curves

The SDDOT currently compares the maximum unit weight and the OMC of four-point compaction data to the Ohio Highway Department's Typical Moisture Density Curves to determine if the curves are valid to be used. Therefore, this study was interested in constructing a region or

prediction interval in which 95 percent of all maximum dry unit weights of base course and subbase materials encountered by the SDDOT would occur. The line of optimums of any family of compaction curves could then be plotted with this interval. Families of compaction curves line of optimums that plot within this region may be considered potentially valid for use with the South Dakota granular base course and subbase materials.

The creation of a prediction interval for South Dakota granular material requires the data be normally distributed. Therefore, histograms were created for all the maximum dry unit weights and OMCs. This data was obtained from all the previously used moisture density relations which included base course and subbase granular material. The histograms are presented in Figure 19 and Figure 20. Although the data representing dry unit weights appears to have a slight rightward skew, the data does appear to be normally distributed.

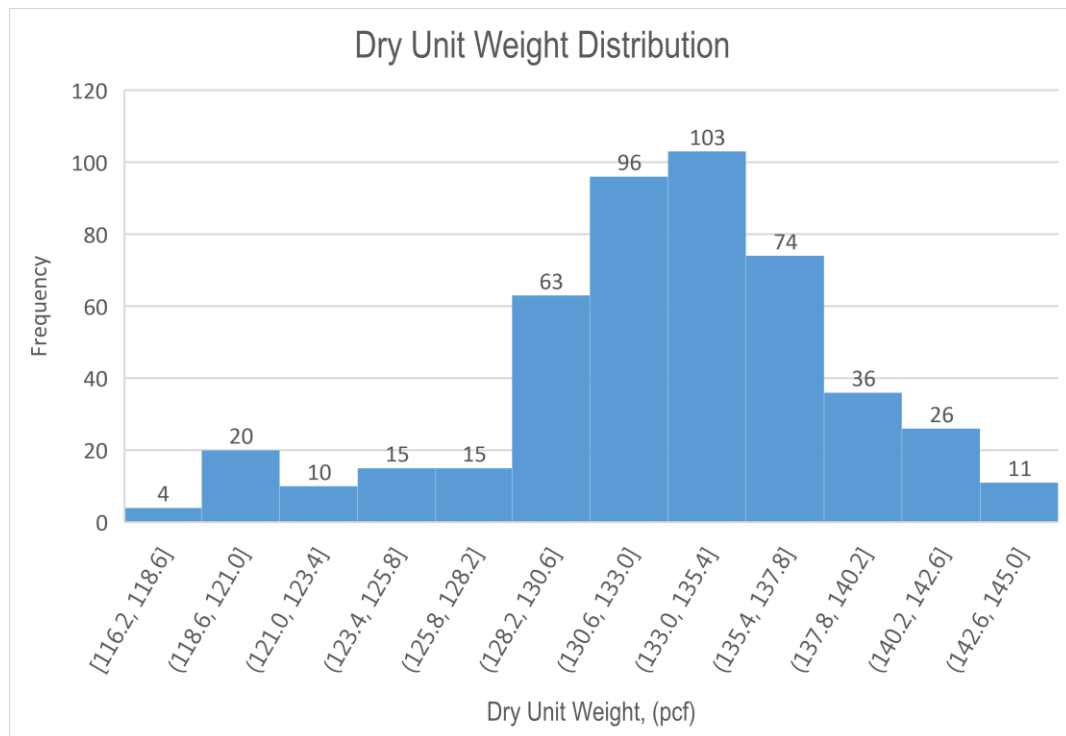

Figure 19: Dry Unit Weight Distribution

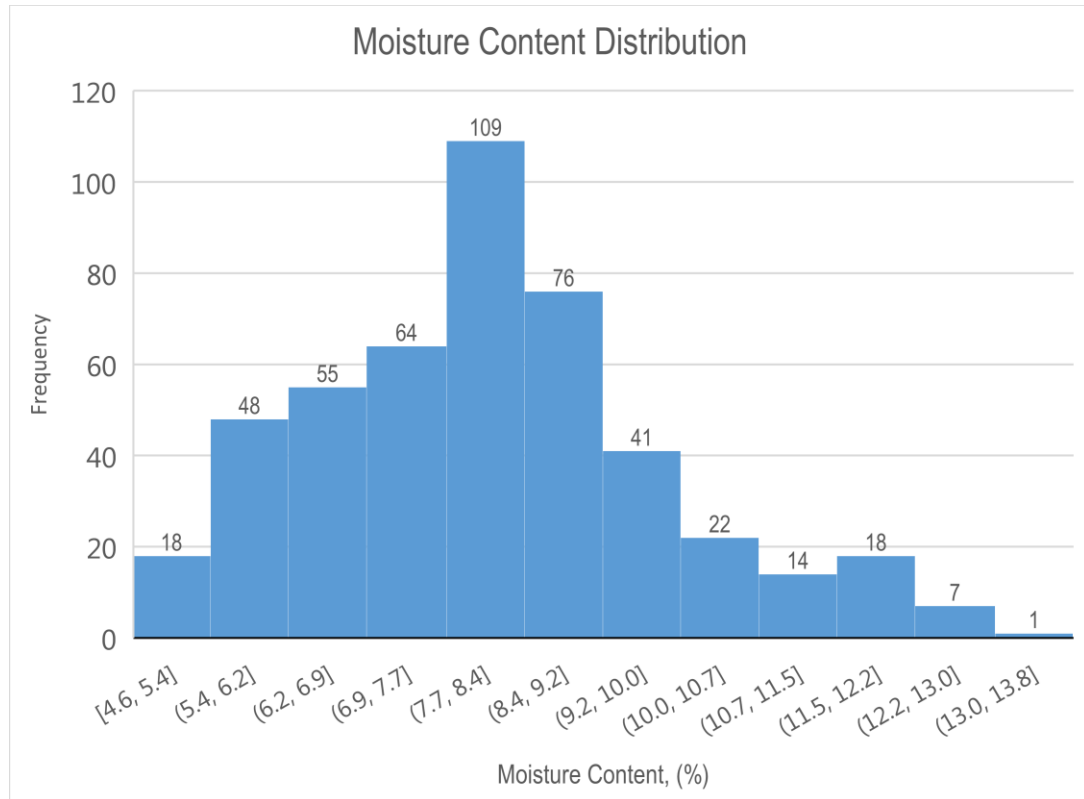

Figure 20: OMC Distribution

The data was then plotted and fitted with several regression models. The regression lines were fitted using the least squares method. It was found that linear, third degree polynomial, and exponential regression models all had low standard and residual standard errors with adjusted coefficients of determination all above 0.60. Each of the regression models are presented in Figure 21 along with the equation for the model and the coefficients of determination. The blue points represent the maximum dry unit weights and OMCs of 474 granular base course and subbase SDDOT moisture density relations used to develop the family of compaction curves. The coefficients of determination for the various models ranged from 0.6407 to 0.6641. The coefficient of determination measures the proportional reduction in variability about the average resulting from the fitting of the regression model.

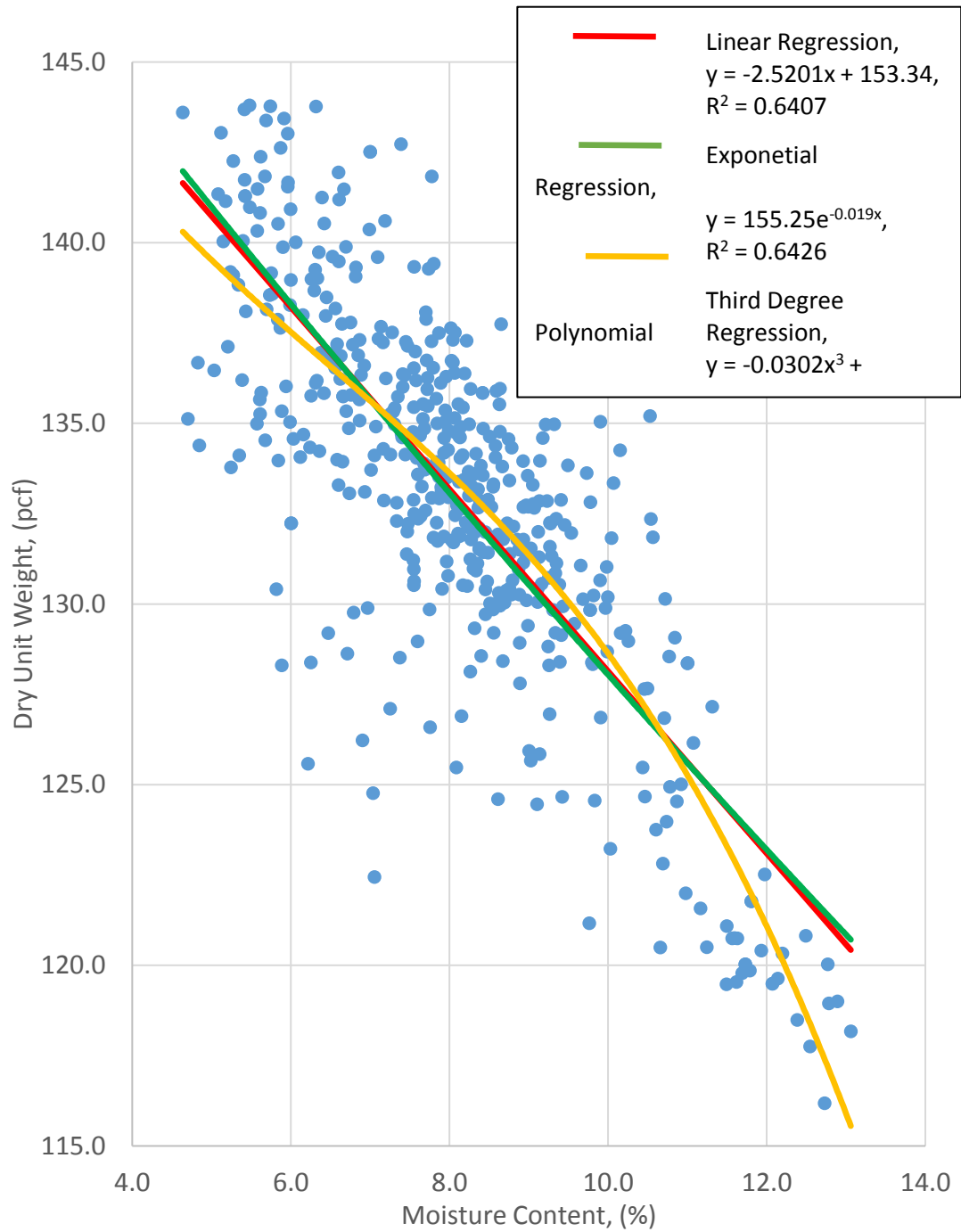

Figure 21: Fitted regression lines for granular moisture density relations.

The residual and standardized residual plots were also analyzed for each model. The residuals represent the measured difference between the observed and predicted dependent variable which for this case was dry unit weight. The residual plots are presented in Figure 22 through Figure 24 and the

standardized residual plots are presented in Figure 25 through Figure 27. The plots were examined to confirm that the residuals were random and not conforming to any observed structure or trend within the data. Observed trends or structures would indicate an invalid model was fit for the data. The orange points shown in the standardized residual plots are considered outliers because they are outside three standard deviations.

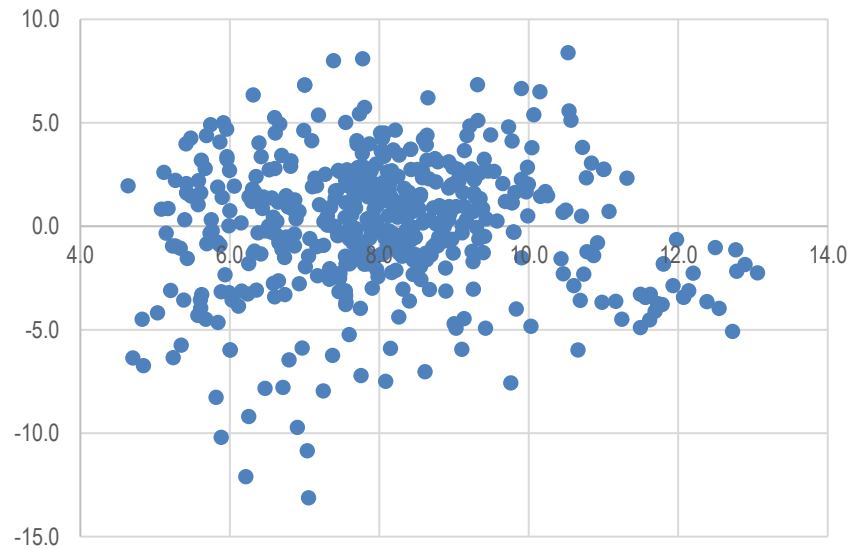

Figure 22: Residual plot for the linear regression model.

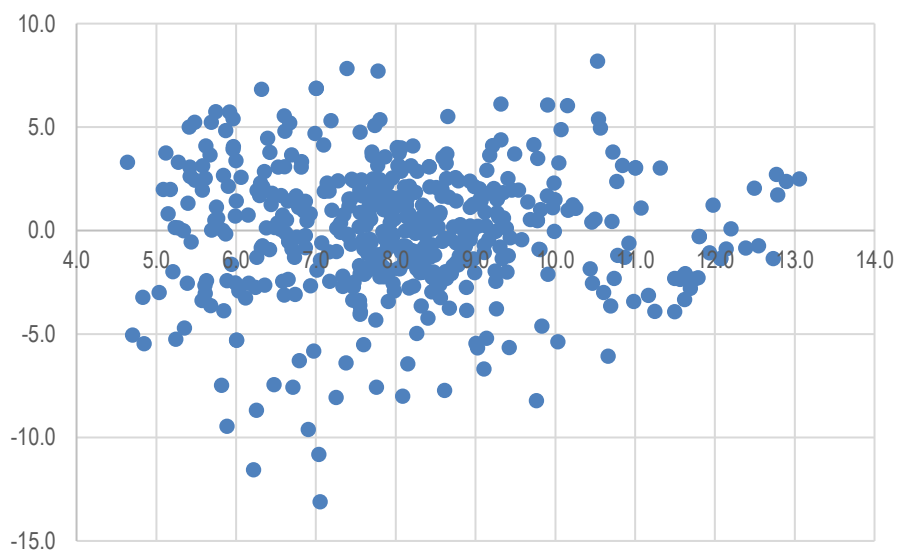

Figure 23: Residual plot for the third degree polynomial model.

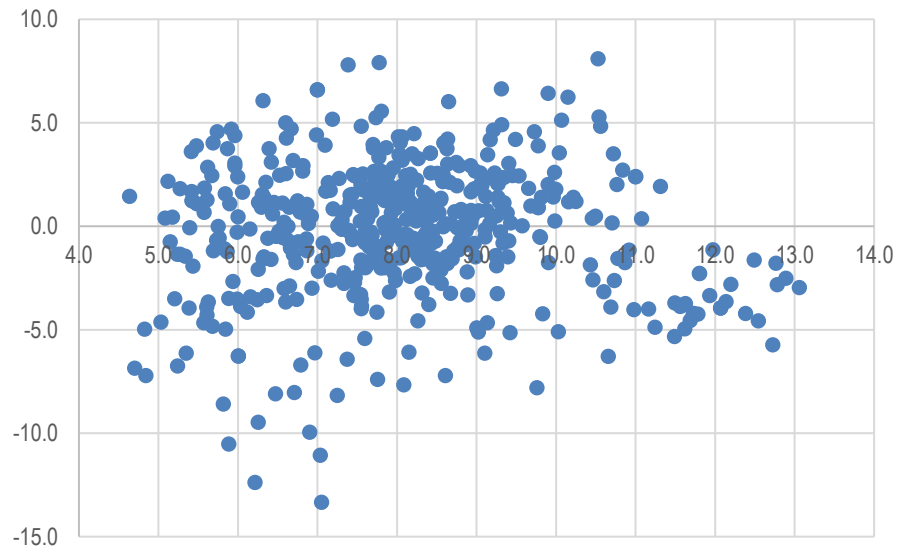

Figure 24: Residual plot for the exponential model.

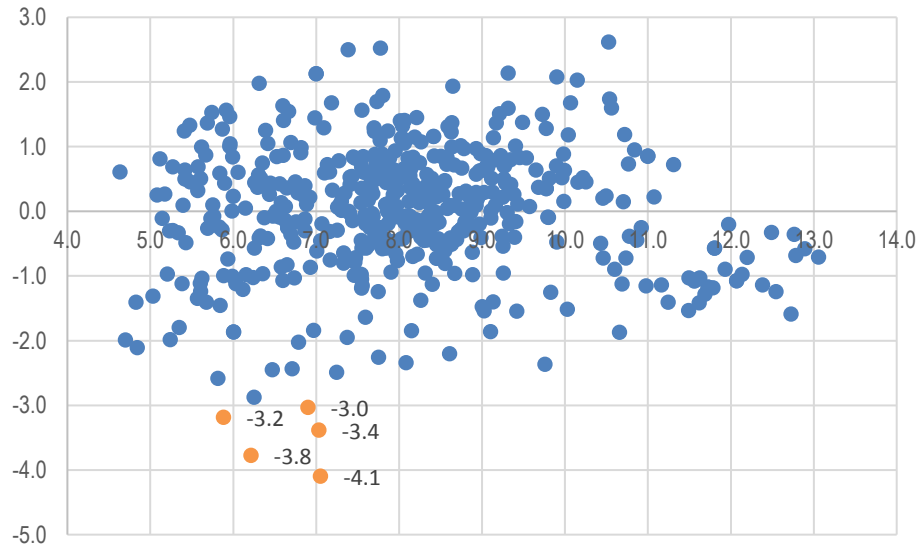

Figure 25: Standardized residual plot for the linear model.

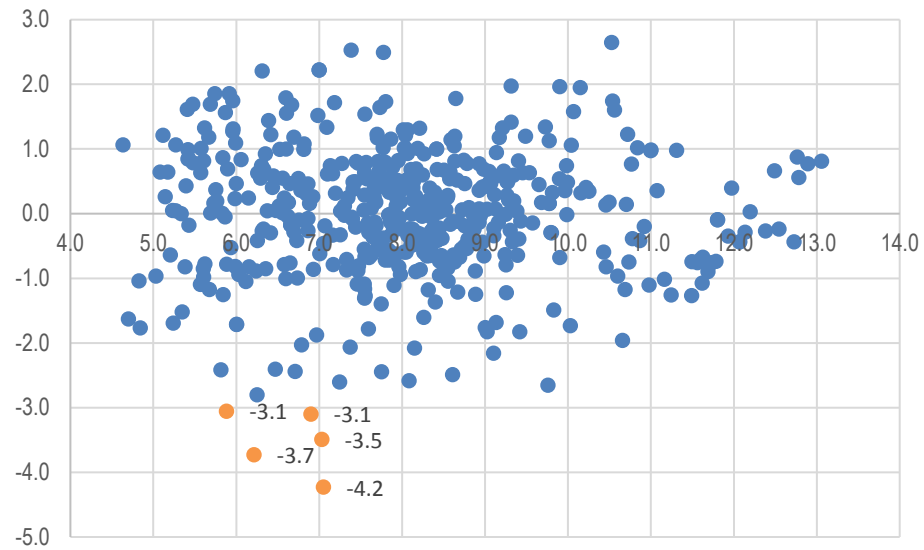

Figure 26: Standardized residual plot for the third-degree polynomial model.

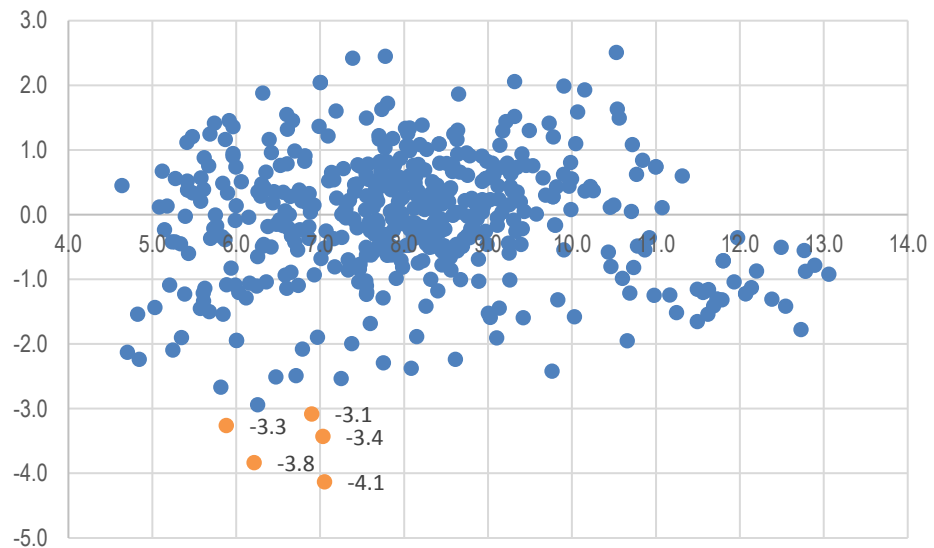

Figure 27: Standardized residual plot for the exponential model.

The residual and standardized residual plots did not indicate a preferred model. Table 10 presents the adjusted coefficient of determination, standard error, and residual standard deviation of each model. The adjusted coefficient of determination provides a proportional reduction in the mean square error rather than in the sum of squared errors. This balances the model fit against its complexity. The number of predictor variables in the model increases the models complexity. The residual standard

deviation may be a better indication of the fit of a model than the coefficient of determination. The residual standard deviation for each model was calculated using Equation 3.3 where n was the number of samples. Therefore, based on the adjusted coefficient of determination, the polynomial model was selected for the creation of a prediction interval.

Table 10: Additional regression model statistics.

	Standard Error	Residual Standard Error	Adjusted Coefficient of Determination
Linear Model	3.206	3.206	0.640
Polynomial Model	3.103	3.103	0.662
Exponential Model	3.015	3.236	0.642

$$S = \sqrt{\frac{\sum(X-X_m)^2}{n-2}} \quad (3.3)$$

where,

S = residual standard deviation

n = number of data points used

X = individual moisture contents for each point used

X_m = mean moisture content of the fitted regression curve

The prediction interval was calculated using Equation 3.4. The prediction interval is a range of values that based on the selected polynomial model creates a region in which 95 percent of the maximum dry unit weights and optimum moistures should lie. This region therefore has a 5 percent error rate. Note that determined alpha level, t_α was 1.96 for a 95 percent confidence. The value n , was the number of data points used, 473. The standard error, SE was calculated to be 3.103. The sum of squared error, SS_{XX} and was calculated to be 1359. The mean moisture content, X_m was found to be 8.1. When an error occurs, the maximum dry unit weight and optimum moisture will lie outside the region created by the prediction interval. The prediction interval is presented in yellow in Figure 28 along with the fitted polynomial regression model in red.

$$Yp = Y \pm t_\alpha SE \sqrt{1 + \frac{1}{n} + \frac{(X-X_m)^2}{SS_{XX}}} \quad (3.4)$$

Where,

Yp = calculated dry unit weight boundaries of the interval

Y = known dry unit weight of the fitted regression curve

t_{α} = alpha level (based on selected confidence level)

SE = standard error

n = number of data points used

SS_{XX} = sum of squared error

X = known moisture contents for the fitted regression curve

X_m = mean moisture content

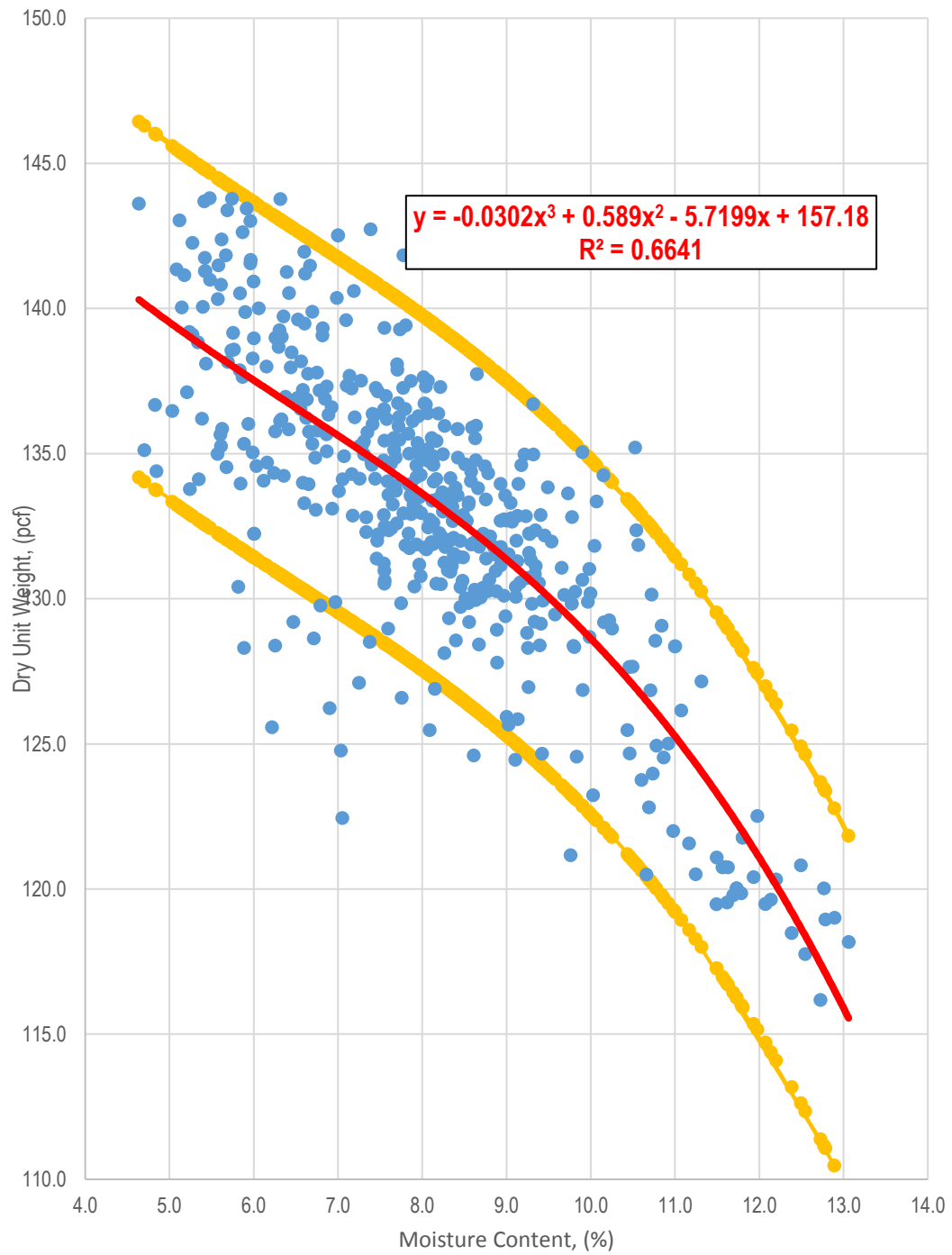

Figure 28: Prediction interval for South Dakota granular subbase and base course materials.

The Ohio Highway Department's Typical Moisture Density Curves line of optimums was also plotted within the prediction interval and regression model to determine if they may be considered potentially valid for use with South Dakota granular base course and subbase materials. The resulting plot is shown on Figure 29. The Ohio Highway Department's Typical Moisture Density Curves are presented in green. The fitted regression line is presented in red and the prediction interval is presented in yellow. The resulting plot indicates that the Ohio Highway Department's Typical Moisture density Curves line of optimums does plot inside the prediction interval. This provides evidence that they may be considered valid for use with South Dakota granular base course and subbase materials. It is important to note that the line of optimums follows the fitted regression line relatively close for dry unit weight values from approximately 121-pcf to 130-pcf. This may indicate that South Dakota base course and subbase materials with maximum dry unit weights within this range may be accurately predicted by the Ohio Highway Department's Typical Moisture Density Curves. However, the line of optimums trends upward away from the fitted regression for dry unit weights greater than 130-pcf and less than 121-pcf. This could result in overestimation of maximum dry unit weights for South Dakota granular subbase and base course materials within these ranges.

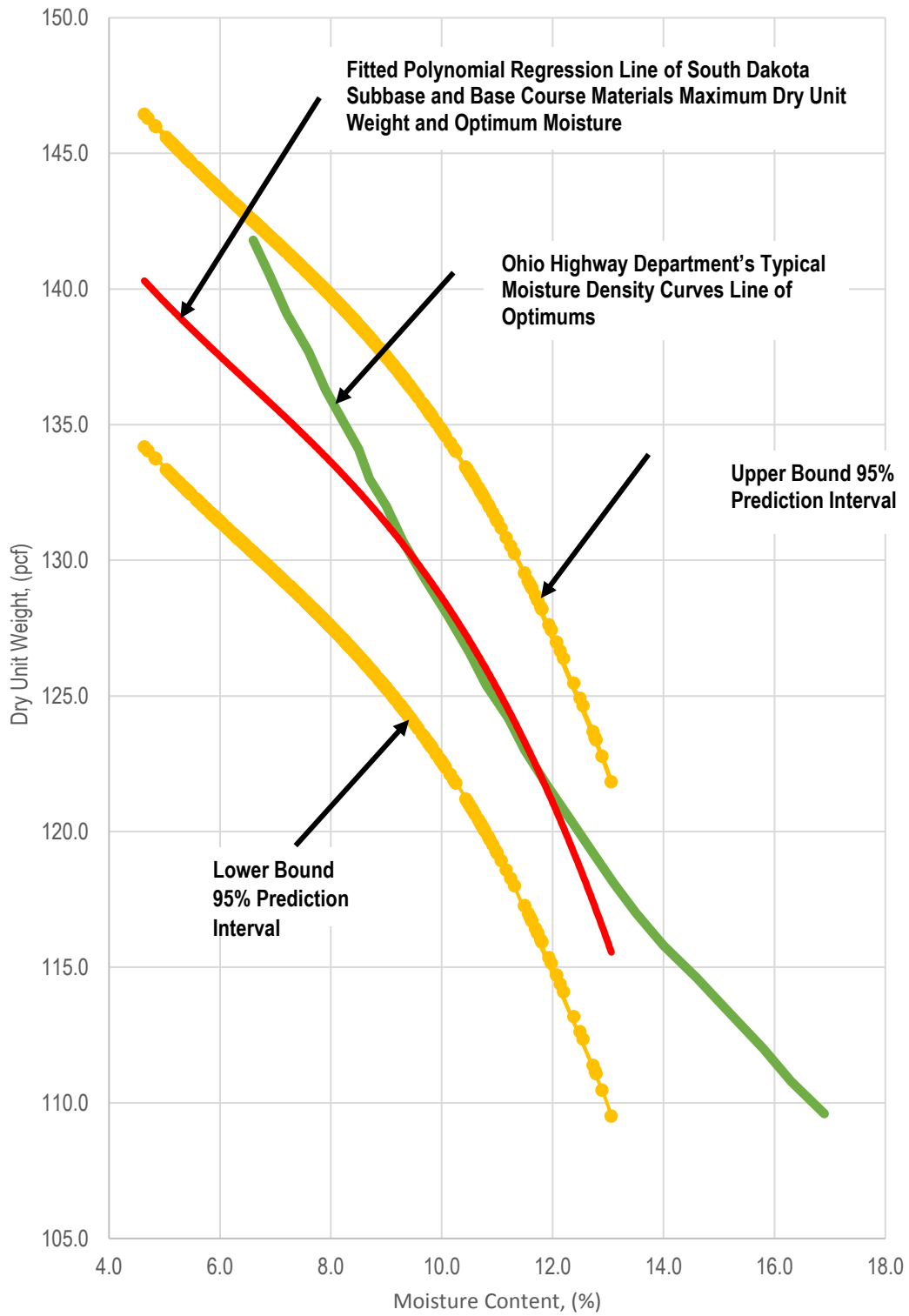

Figure 29: Line of optimums plotted within the 95 percent prediction interval.

3.5 Summary of Survey Results

This research conducted a survey of other state DOT's to document their methods, procedures, equipment, and training requirements for granular compaction testing. The survey also intended to collect data on alternative testing methods utilized by surrounding DOT's and DOT's utilizing families of compaction curves through the literature review. The NCHRP conducted a comprehensive survey of state DOT's to document compaction methods and practices (Nazzal, 2014). Therefore, to avoid generating duplicated information, two separate but similar questionnaires were created to gather new information. One questionnaire (Form 1) was sent to DOT's that had responded to the NCHRP Synthesis survey and the other questionnaire (Form 2), was sent to those who did not respond to the NCHRP Synthesis Survey. Survey Questionnaire Form 1 is present first followed by Survey Questionnaire Form 2 in Appendix C. Table 11 lists the states that received a questionnaire, which form was sent, and those who replied. The response rate for the surveys was 44 percent.

Table 11: Survey recipients.

State DOT's Recipients	Form Received	Responded
North Dakota	Form 1	No
Montana	Form 1	No
Minnesota	Form 1	Yes
Nebraska	Form 1	No
Indiana	Form 1	No
Ohio	Form 1	Yes
Wyoming	Form 2	No
Iowa	Form 2	Yes
Texas	Form 2	Yes
Response Rate		44%

The questionnaires consisted of 14 questions designed to be answered quickly to increase the response rate. Table 12 presents relevant information from the surveys. Detailed responses can be found in Appendix C. Minnesota was the only state to use a strength measurement device, the DCP. All other respondents used density measurement devices to conduct compaction quality control. All of the respondents except for Texas have implemented families of curves on granular material for field projects. The survey provided several options of the various DOTs to select when asked their

experience using families of curves. Options were: implemented in field projects, demonstrated in usage, evaluated, and not used. The intent of the options was to gauge how extensively each DOT has used families of curves. Those that have specifications and test procedures were to select the option “Implemented in Field Projects.” DOTs that have selected “Demonstrated Usage” are those that have implemented families of curves in pilot projects. DOTs that have evaluated families of curves while conducting research would select the option “Evaluated.” It was also noted that all respondents used field microwave, NDG, and oven or stovetop methods to determine moisture content. The Minnesota DOT also used Speedy Moisture Testers. Compaction quality control on HMA and PCC recycled materials is performed by all the responding states except Iowa.

Table 12: Survey response information of interest.

State	Compaction Test Method	Compaction Specification	Usage of Families of Curves	Materials Utilized by Curves
Minnesota	Dynamic Cone Penetrometer	1-points and 4-points	Implemented in field projects and demonstrated in usage	sands, gravels, and limestone
Iowa	Sand Cone and Balloon	1-points and 4-points	Implemented in field projects	Sands
Ohio	Nuclear Density Gauge	1-points and test strips	Implemented in field projects	sand and gravels
Texas	Sand Cone, Electric Density Gauge, Soil Density Indicator, and Nuclear Density Gauge	4-point	Not used or Evaluated	N/A

4.0 DISCUSSION OF ALTERNATIVES

An objective of the research was to determine whether an alternate method of testing compaction of unprocessed and recycled granular material should be used. These alternatives are presented in this chapter. The various compaction testing methods have been divided into two general categories: density-based and stiffness / strength based. These categories relate to what parameter is measured when performing a test. Density-based methods depend on obtaining a measure of dry unit weight and moisture content to determine acceptable levels of compaction. Stiffness / strength-based methods measure soil resistance to dynamic and static loading and correlate directly to engineering input into the design such as mechanistic empirical pavement design. The following section will discuss and present the alternatives comparison used.

4.1 Alternatives Comparison

A criteria list was developed to rank test devices based on the list of alternatives presented in Chapter 2. These criteria are presented in with general descriptions for each. The alternatives were ranked from 1 to 3 relative to the other alternatives. For example, a relatively inexpensive test device would receive a rank of 1 for relative cost. An expensive test device would receive a 3, with moderately expensive devices receiving a 2. The devices were scored relative to the other alternatives. This scheme was used for the criteria listed in Table 13. The criteria list was then used to score the test devices. The scoring of each test devices was based on information presented in the literature review and survey results previously presented in Chapter 2 and Chapter 3.

Table 13: Decision Criteria.

Criteria List	Description of Criteria
Relative Cost	Relates the cost of the device relative to the other alternatives.
Ease of Use	This is a measure of how easy it is to operate the device.
Repeatability	This is a measure of how repeatable results are.
Reliability	A measure of the structural and technical reliability of the device.
Accuracy	How well the device measures actual soil properties. This is generally a measure of possible device testing error.
Safety	A measure of how safe the device to operate.
Test Time	A measure of how long does it takes to conduct a test.
Correlations	A comparison of the number of correlations between measurements and soil properties.
Expertise Level	A measure of the level of technical ability required to operate the equipment.

The results of the scoring are presented in Table 14 with the lowest scores representing the most desirable options. The devices were grouped into three categories. The first category was for devices currently used by the SDDOT, which are all density-based. The second category was for other density-based devices from the literature review. The final category was for stiffness / strength based devices. The lowest score from currently used SDDOT devices was the NDG with the sand cone device scoring close in comparison. The DCP scored the lowest overall score.

Table 14: Criteria Scoring Scheme

Device Category		Relative Cost	Ease of Use	Repeatability	Reliability	Accuracy	Safety	Test Time	Correlations	Expertise Level	Total Score
Current SDDOT (Density-Based)	Sand Cone	1	1	3	2	3	2	3	3	1	19
	Rubber Balloon	1	3	3	2	3	2	3	3	1	21
	Nuclear Density Gauge (NDG)	3	1	2	1	2	2	1	3	2	17
Density-Based	Moisture Density Indicator (MDI)	2	3	1	3	2	2	3	3	3	22
	Electric Density Gauge (EDG)	3	3	1	3	2	2	3	3	3	23
	Soil Density Gauge (SDG)	3	3	1	2	2	2	3	3	3	22
Stiffness / Strength-Based	Clegg Hammer (CH)	3	2	3	1	3	1	3	2	1	19
	GeoGauge	2	3	3	1	3	2	2	3	2	21
	Light Weight Deflectometer (LWD)	2	2	1	1	2	1	1	1	2	13
	Dynamic Cone Penetrometer (DCP)	1	1	1	2	2	1	1	1	1	11

4.2 Discussion of Scoring

Considerations for each criterion were carefully examined. Most of the criteria are considered linked in one form or another. “Relative Cost” considerations include not only the cost of the device but also the cost to implement and training of operators. Training and implementation are also considered when scoring the criteria “Level of Expertise” and “Ease of use”. The following subsections discuss in detail how each device was scored.

4.2.1 Current SDDOT (Density-Based) Devices

The category presented in Table 14 as Current SDDOT Devices presents three density-based devices currently used by the SDDOT. These devices were the Sand Cone, Rubber Balloon, and NDG. The relative cost to own and operate the Sand Cone and Rubber Balloon are low compared to other methods. However, the cost of owning and operating a NDG includes cost to own, store, and operate as well as inspector certification which cost much more than other alternatives. The Sand Cone and Rubber Balloon received scores of 2 because of the need to kneel on the job site to operate these devices and therefore increases the risk of being unseen by passing construction equipment, and the traveling public.

The results obtained from the Sand Cone and Rubber Balloon have been previously shown to be operator dependent. Therefore, these devices received high scores for repeatability, reliability, and accuracy. The NDG scored slightly better in these categories as the results are not as reliant on the operator. The NDG does not perform well in recycled materials and therefore received a 2 for accuracy. The NDG also has been found to be a durable device that can be used with limited maintenance throughout its lifetime, hence the low reliability score.

All the devices currently used by the SDDOT require a relatively low level of expertise to operate. It is important to note however, that the operator must have regulatory mandated training to operate the NDG. Results are obtained relatively quickly when using the NDG which makes it very attractive to some DOT’s. The Sand Cone has a time-consuming calibration process and test results require considerable time. The Rubber Balloon was noted in studies to break in rock materials resulting in a failed test. These findings make the Rubber Balloon device a relatively undesirable option as tests can be difficult to perform in granular material.

4.2.2 Density-Based Devices

The category presented in Table 14 Density-Based Devices presents three alternative density-based devices currently not used by the SDDOT. These devices include the MDI, the EDG, and the SDG. All of these devices received moderate cost scores due to the fact that they do not require training to own and operate. These devices are still expensive when compared to other devices such as the Sand Cone or DCP. These devices also require the operator to kneel on the job site, putting the operator at risk of injury from construction equipment or the traveling public.

The literature found that all three of these devices when operated correctly can produce results similar to the NDG and therefore received a 2 for accuracy. The literature review also found these three devices to be repeatable. Reliability of these devices varied between studies, however a common criticism was the bending of spike probes in densely compacted granular materials. Therefore, these devices all scored high for reliability.

It was reported that there was a high level of expertise required to operate all three of these devices and performing testing was a time consuming and complicated process. This resulted in high scores for expertise level, ease of use, and test time. These findings resulted in these devices being relatively undesirable alternatives. It is also important to note that wide-spread use of these devices by other DOT's was not found although some have evaluated their use. This may be an indication of disadvantages associated with these devices.

These devices, along with those currently used by the SDDOT, do not have direct correlations to soil properties and therefore received high scores for correlations. The lack of correlations between density-based methods and soil properties presents disadvantages to these devices. Pavement design uses mechanistic empirical design criteria that use soil properties such as resilience modulus to determine pavement thickness as input.

4.2.3 Stiffness / Strength Based Devices

The last category presented in Table 14 is Stiffness / Strength-Based devices. This category included the CH, the GeoGauge, the LWD, and the DCP. The relative cost of owning and operating these devices varied. The least expensive to own and operate was the DCP with a cost to own of approximately

\$1,500. The CH was approximately \$20,000 making it the most expensive device to own. The LWD and GeoGauge were found to have moderate cost values relative to the other devices. A summary of approximate device costs for all the devices summarized was shown Section 2.6. All of the devices in this category other than the GeoGauge can be operated from a standing position and none of them require the use of radiation to obtain measurements. Therefore, these devices received low safety scores. The GeoGauge does require the operator to kneel on the job site which is the reason for a higher safety score.

The CH and GeoGauge were found to be difficult to seat on granular material therefore, resulting in high scores for repeatability and accuracy. The LWD and DCP were found to obtain repeatable and accurate results. The DCP scored higher for reliability when compared to the alternative devices. The DCP has cone tips that must be replaced after each test increasing its reliability score. The other three stiffness / strength devices all received low reliability scores.

The level of expertise required to operate these devices is relatively low. The GeoGauge and LWD require understanding the built-in operating systems to correctly perform tests. However, the CH and DCP both require minimal training to operate effectively. Test times for these devices are moderately low with the exception of the CH which requires the operator to obtain test values from laboratory compaction molds prior to its use in the field. The LWD and DCP are able to rapidly obtain test data in granular material making them desirable options. The DCP is also easy to operate in both granular and recycled materials scoring low for ease of use. The literature review noted that the CH GeoGauge, and LWD had difficulties performing tests in granular material. The difficulties usually stemmed from the seating of the devices on surface of granular materials. The GeoGauge and CH were also found to be rather heavy and difficult to maneuver around job sites.

The main advantage of stiffness / strength devices is their ability to obtain data that can be easily and effectively correlated to design criteria. All of these devices have the ability to correlate their data to the engineering properties of the soil such as the CBR and resilience modulus. These engineering properties are also used in mechanistic empirical pavement design, thus providing a link between the design of pavement sections and the quality control of pavement support.

5.0 FINDINGS AND CONCLUSIONS

Throughout the research process, numerous findings were obtained that resulted in the recommendations that are presented in Chapter 6. The findings of the research were produced in three general areas. The literature review documented many findings from previous research reports and aided in the understanding of current SDDOT practices and issues when conducting compaction quality control on granular materials. The surveys conducted coupled with the NCHRP synthesis survey, provided feedback from surrounding DOT's current compaction quality control methods. The surveys also provided valuable information on the types of alternative devices evaluated by other DOT's. A data analysis was performed on compaction data provided by the SDDOT. The data analysis provided an evaluation of the Ohio Highway Department's Typical Moisture Density Curves as well as provides a new set of curves, the SDDOT Base and Subbase Moisture-Density Curves. These new curves were developed from the same data analyses. The following sections will present a summary of the major findings from each of the three general areas.

5.1 Literature Findings

The literature review found that granular materials compact and drain fundamentally different than clays and silts. Studies found that when granular materials are compacted using the standard laboratory compaction test with standard compaction molds, the resulting maximum dry density maybe underestimated. Further studies indicated that granular material can be compacted to a higher maximum dry density under laboratory vibratory compaction. The vibrating laboratory compaction method compacts granular material in a similar manner to how it is compacted in the field using a vibrating roller. Effective laboratory compaction of granular material is essential in ensuring adequate density-based compaction in the field. It was also found that density-based compaction quality control results do not directly correlate to the soil properties used in pavement design.

The literature review also reviewed the use of families of compaction curves. It was found that families of curves were originally designed for cohesive soil material such as clay and silty clay. These curves used both wet density and penetration resistance to select proper curve fits. The Ohio Highway

Department's Typical Moisture Density Curves, Set C that are now used by the SDDOT do not include penetration resistance measurements to select the proper curve fit.

There were 10 compaction testing devices researched and summarized in the literature review. The devices were divided into three categories: Current SDDOT (Density-Based), Density-Based, and Stiffness / Strength-Based. The current SDDOT devices were the Sand Cone, the Rubber Balloon, and the NDG. The density-based devices were the MDI, EDG, and SDG. The stiffness / strength based devices were the CH, GeoGauge, LWD, and DCP. Summarized literature found that although the CH was the most expensive to purchase, the NDG was the most expensive to own and operate. That stated, most DOT's still use the NDG for compaction quality control. The various alternatives to the NDG all had issues obtaining quick, repeatable, reliable, and accurate test results. Stiffness / strength based devices were found to provide quicker testing times and required less expertise to operate. These devices also did not depend on the experience of the operator in contrast to the Sand Cone and Rubber Balloon. Studies did show problems seating the CH, GeoGauge, and LWD on granular materials. The summary of each device can be found in Sections 2.4 and 2.5. The scoring evaluation is presented in Chapter 4.

5.2 Survey Findings

The research team conducted a survey of other state DOT's to document their methods, procedures, equipment, and training requirements for granular compaction testing. The survey also aimed to collect data on alternative testing methods utilized by surrounding DOT's and DOT's found to be utilizing families of curves through the literature review. Of the nine DOT's surveyed, four responded: Minnesota, Iowa, Ohio, and Texas. The survey results found that Texas was currently using the Sand Cone, EDG, SDI, and NDG. This indicates that Texas is still focused on density-based compaction quality control along with Iowa and Ohio. The Minnesota DOT has implemented the DCP for compaction quality control and recommended its use for granular materials. All the respondents with exception to Texas indicated that they also use families of curves in projects that use sands and gravels. A copy of the surveys and survey results are presented in Appendix C. A summary of the survey results can be found in Section 3.5.

5.3 Data Analysis Findings

The goal of the data analysis task was to provide analysis that would aid in the evaluation of the Ohio Highway Department's Typical Moisture Density Curves adequacy in determining target dry unit weight. It was first necessary to compare the line of optimums of the Ohio Highway Department's Typical Moisture Density Curves to the line of optimums created from granular subbase and base course materials encountered by the SDDOT. The results of the comparison indicated that the Ohio Highway Department's curves may be overestimating the maximum density in the field by nearly three pcf. This would contribute to a 2 to 2.5 percent difference in maximum dry unit weight.

A 95 percent prediction interval on the maximum dry unit weight and optimum moisture of granular subbase and base course materials encountered by the SDDOT was also constructed to evaluate the families of curves. Both the Ohio Highway Department's Typical Moisture Density Curves and the newly created SDDOT Base and Subbase Moisture-Density Curves fit within the 95 percent prediction interval. This indicated that the both families of curves may be considered valid for compaction quality control of granular materials. The SDDOT Base and Subbase Moisture-Density Curves were developed using base and subbase materials encountered by the SDDOT. The Ohio Highway Department's Typical Moisture Density Curves were proven to be statistically different than the SDDOT granular material line of optimums by approximately 2.8-pcf. Current SDDOT methods state target densities determined by a family of compaction curves should range within 3-pcf of the maximum dry unit weight from modified laboratory compaction tests. The analysis process was documented in Chapter 3. The data used during the analysis is presented in Appendix B. Procedures, Methods, and Specifications for the SDDOT Base and Subbase Moisture-Density Curves are presented in Appendix A.

5.4 Research Conclusions

The findings of the research have found that there are many disadvantages associated with density-based compaction quality control. Density-based compaction quality control also does not provide a direct link between the design process and construction quality control of granular material compaction. It was found that many state DOT's still use density-based devices, and some are currently implementing new devices for measuring density. However, previous studies of new density-based quality control devices

have noted the unsuitability of these devices in granular material. Minnesota has studied new stiffness and strength measurement devices and are implementing methods, procedures, and specifications for the use of the LWD and DCP. The review of previous studies indicates that the DCP is a viable option for the SDDOT to increase efficiency and reduce the problems encountered using density-based devices on granular base and subbase materials.

The use of families of curves for granular materials is currently in use by surrounding DOT's. The SDDOT currently uses the Ohio Highway Department's Typical Moisture Density Curves to aid in the determination of maximum dry unit weight and optimum moisture of granular materials. The data analysis has found that this may be leading to approximately 2.8-pcf overestimation in maximum unit weight. This could indicate that compacted fills in the field may be overly compacted leading to unnecessary construction costs. The analysis also indicates that the Ohio Highway Department's Typical Moisture Density Curves may still be considered valid for use in compaction quality control of granular materials. Therefore, it would be an advantage for the SDDOT to consider using the new SDDOT Base and Subbase Moisture Density Curves for future construction projects.

The conclusions resulting from the research should be implemented by the SDDOT in an incremental process. The DCP can be implemented as a compaction quality control device for granular base and subbase materials. Methods, procedures, and specifications for the device are presented in Appendix A. The use of the Ohio Highway Department's Typical Moisture Density Curves should be used alongside the new SDDOT Base and Subbase Moisture Density Curves on part of a future project. This would allow the SDDOT to evaluate and compare both families of curves relative to each other. The pilot project would also serve to verify the usage of the DCP as an alternative to field quality control testing. A discussion of these recommendations and the implementation process is presented in Chapter 6. Estimated costs for the recommendations to be implemented are summarized in Table 15 based on SDDOT estimates (SDDOT, 2016). These costs include the integration of the new testing reports and forms along with the cost of training and purchasing of the DCP devices.

Table 15: Estimated Implementation Costs.

	Quantity	Cost	Total
SDDOT Base and Subbase Moisture Density Curves	20 hours	\$69.00	\$1,380.00
3 New Forms for DCP	60 hours	\$69.00	\$4,140.00
New Reports for DCP	10 hours	\$69.00	\$690.00
DCP Purchase	24 each	\$1,000.00	\$24,000.00
Training	1 each	\$2,000.00	\$2,000.00
Grand Totals	114 hours	\$3,207.00	\$31,589.00

6.0 RECOMMENDATIONS AND IMPLEMENTATION

This chapter presents the research team's recommendations to the SDDOT based on the research findings and conclusions. The research team recommends that the new methods, procedures, and specifications recommended be reviewed through an implementation pilot project before full implementation. This pilot project is considered the third recommendation.

6.1 The SDDOT Base and Subbase Moisture Density Curves

The research team recommends that the SDDOT use the newly developed SDDOT Base and Subbase Moisture Density Curves from this research for determining the maximum dry unit weight and optimum moisture of granular base and subbase materials.

The research developed a new family of compaction curves to be utilized in base and subbase material compaction quality control. These moisture density curves will be referred to as the SDDOT Base and Subbase Moisture Density Curves. Moisture density relations of base and subbase material types described by the SDDOT were analyzed in the creation of the curves and originated from the curves presented in Figure 17 in Section 3.2. The SDDOT Base and Subbase Curves are represented in

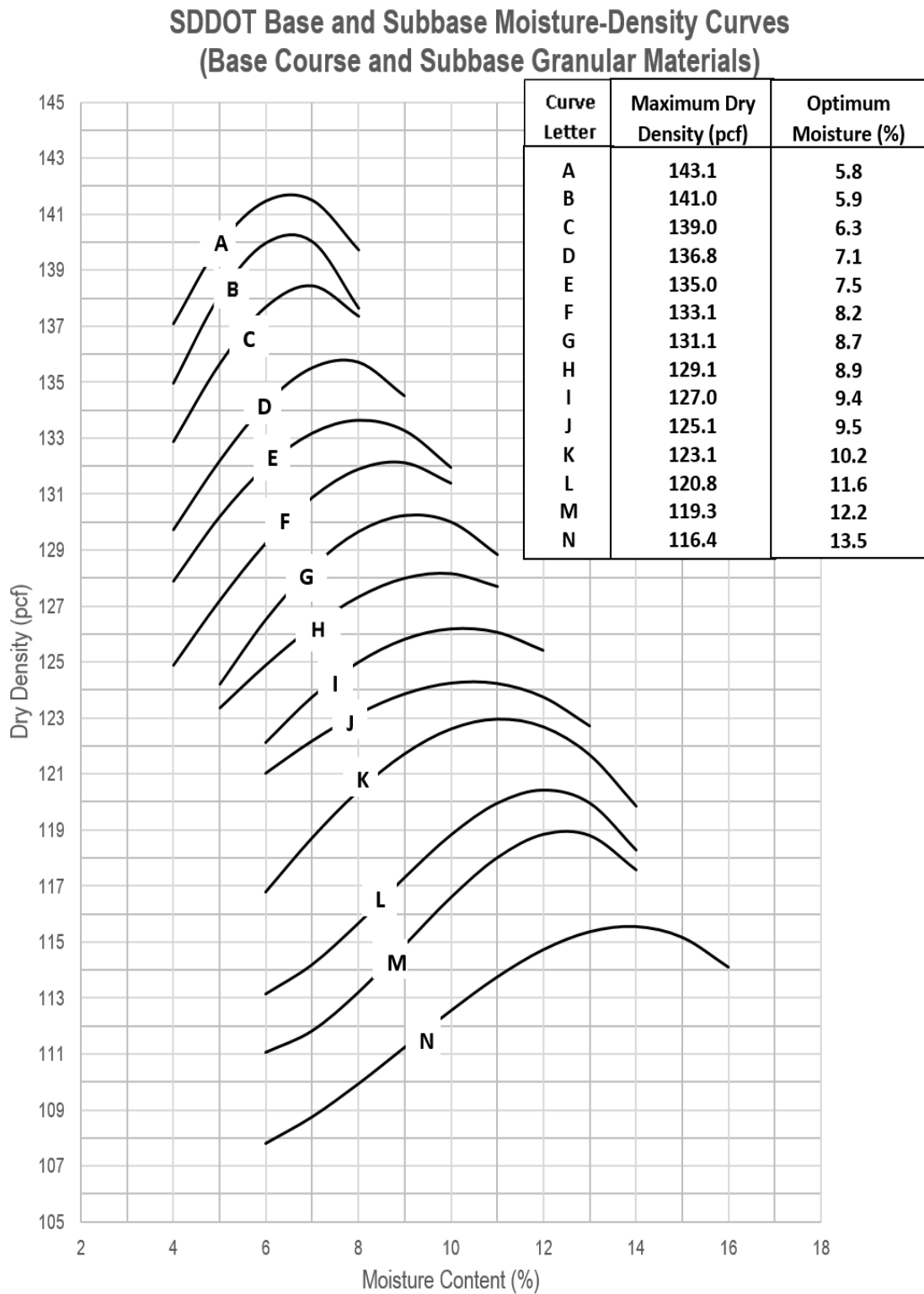

Figure 30. These curves were plotted with the regression model discussed in Chapter 3. The SDDOT Base and Subbase Moisture Density curves line of optimums shown in

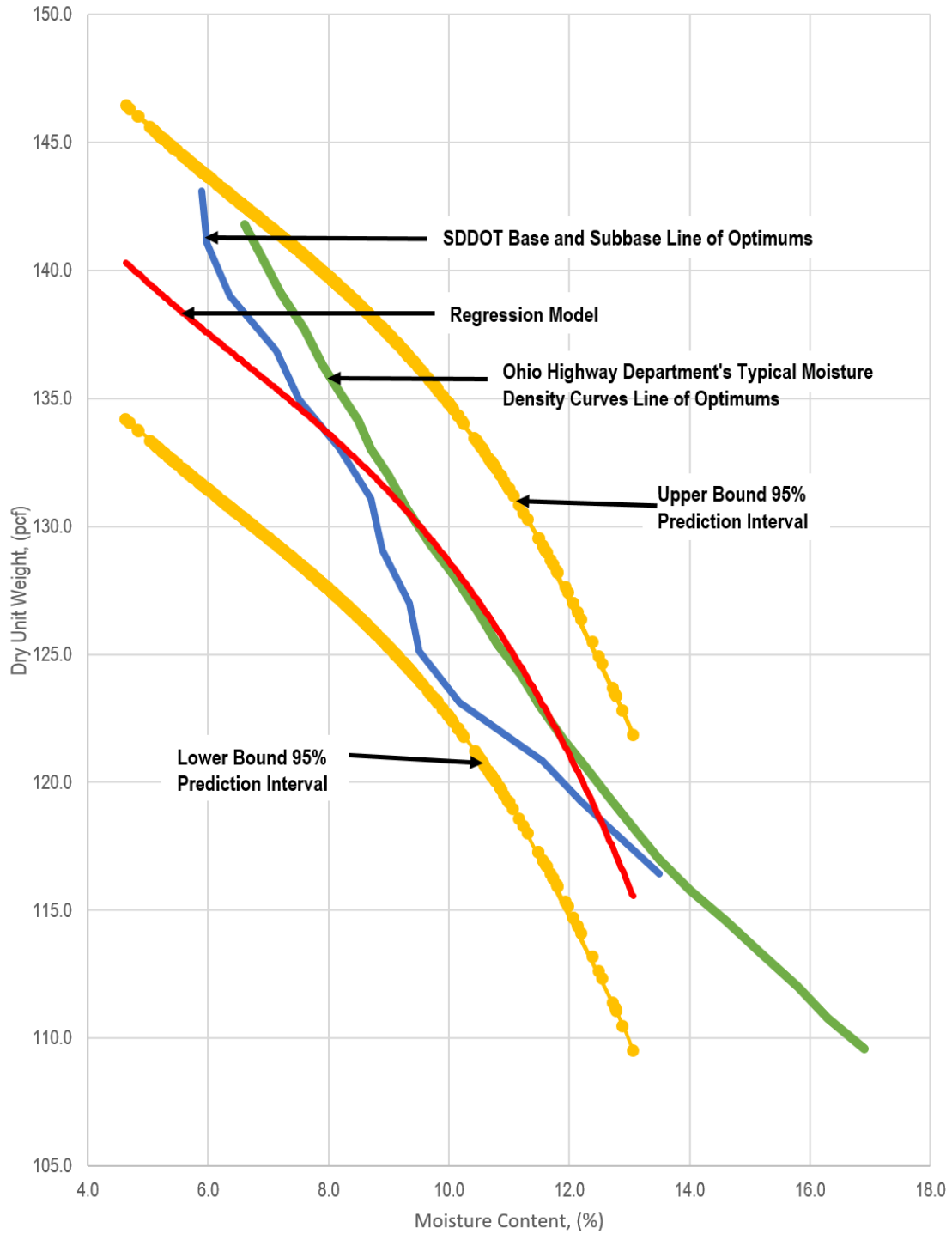

Figure 31 (combination of Figure 18 and Figure 28) in blue did slightly follow a more effective regression model than the previously plotted Ohio Highway Departments Typical Moisture Density Curves shown in green. Of particular note is that the new curves have been created from moisture density relations of granular materials encountered by the SDDOT thus making them a more desirable option. The new family

of compaction curves also does not deviate outside the 95 percent prediction interval, therefore indicating that they may be considered valid in predicting base and subbase maximum dry densities and optimum moistures. Please note that creating the new family of curves was not in the defined scope of work; they were created as part of satisfying other portions of the defined work for this project. Therefore, their use and implementation will need to be vetted as described in this chapter to be considered for standard field use.

SDDOT Base and Subbase Moisture-Density Curves (Base Course and Subbase Granular Materials)

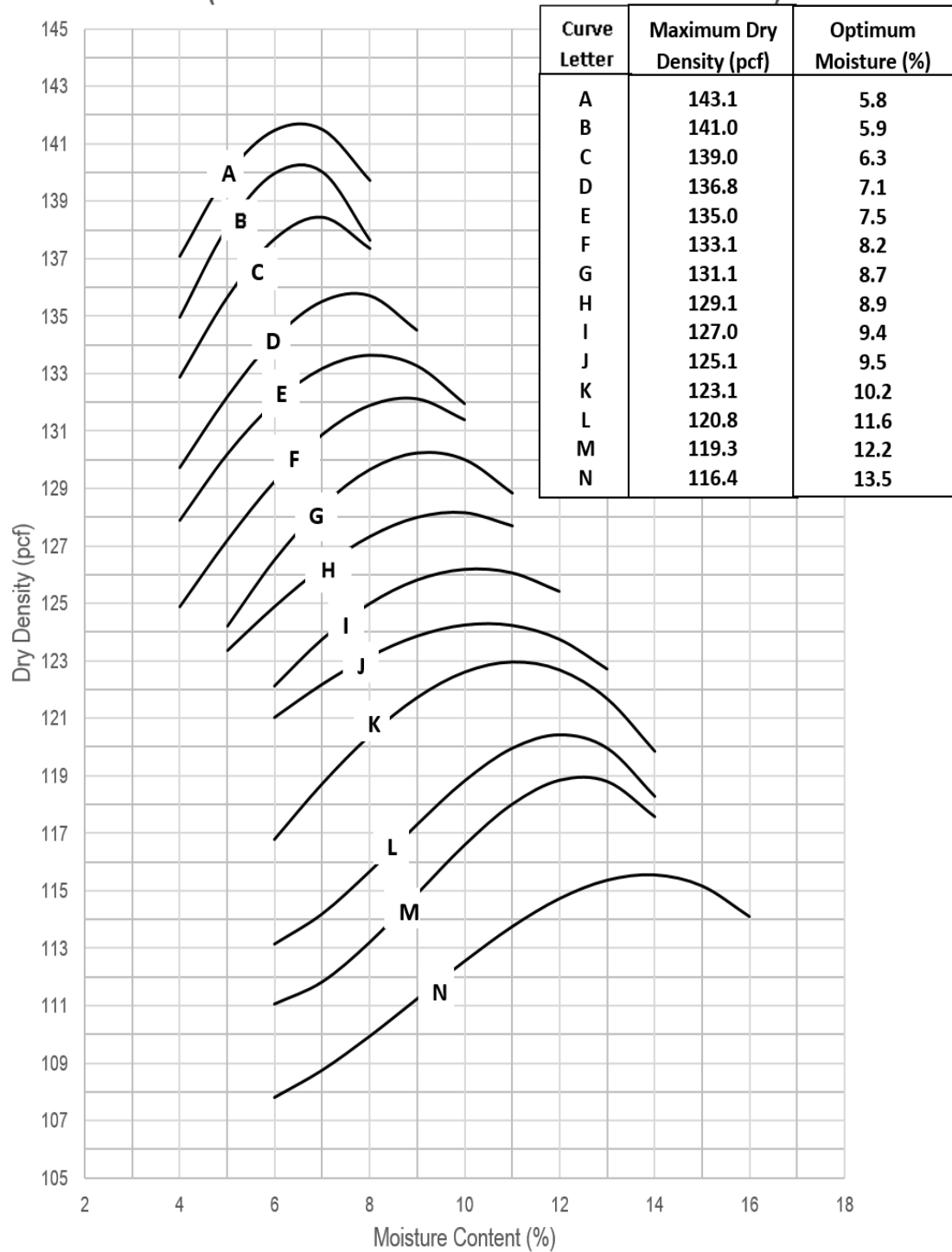

Figure 30: The SDDOT Base and Subbase Moisture Density Curves.

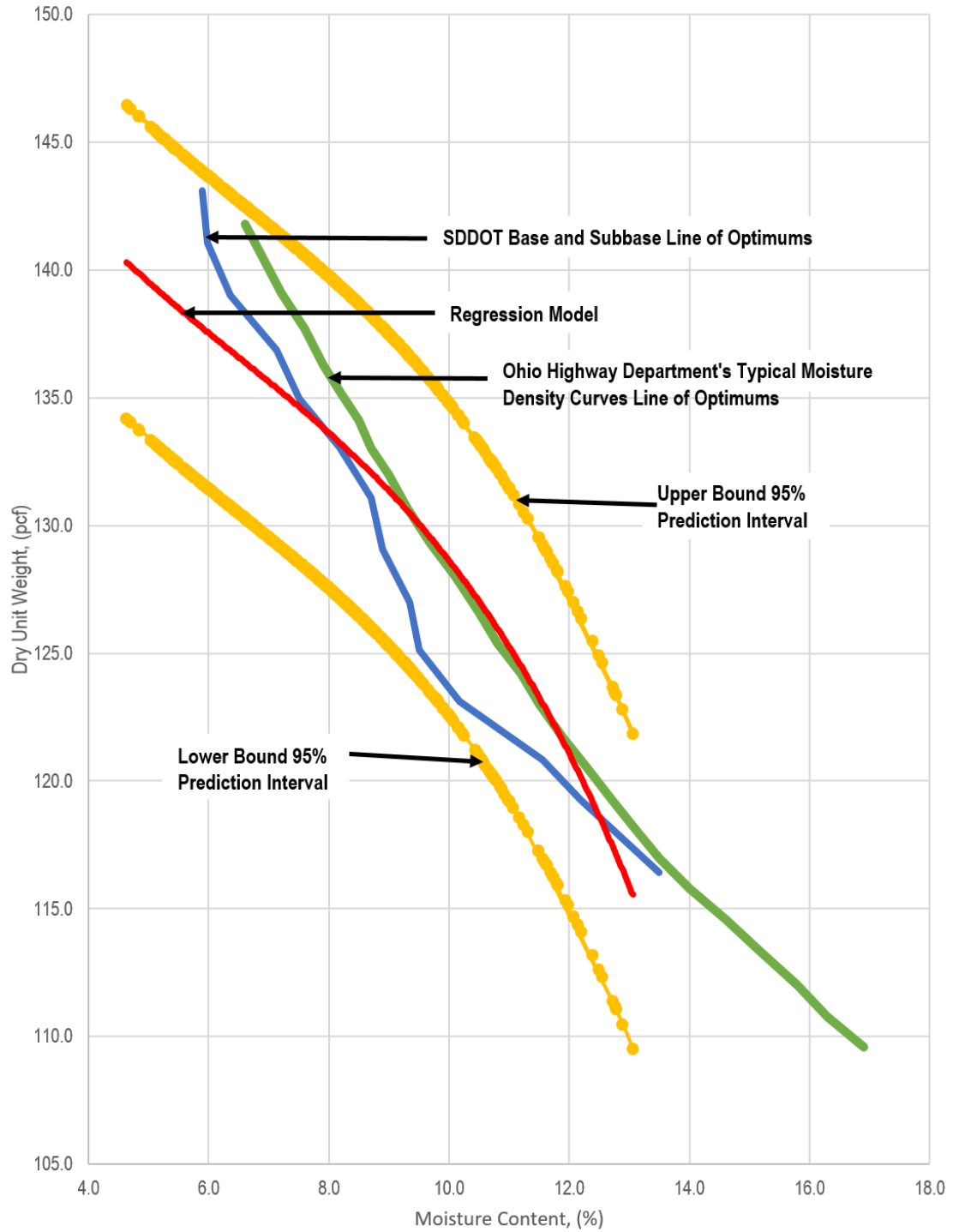

Figure 31: Lines of optimum comparison plotted within Prediction Interval.

The method the SDDOT uses to reduce laboratory data computes the “wet” unit weight as a function of the weight of the mold, the weight of the “wet” material, and a mold factor from a standard

proctor test using the SD 104 methods. The dry unit weight is computed from the “wet” unit weight and the moisture content using Equation 6.1.

$$\gamma_w = [(w_w + w_m) - (w_m)] * MF \quad (6.1)$$

Where,

γ_w = wet unit weight, pcf

w_w = weight of wet material, lbs

w_m = weight of mold, lbs

MF = Mold factor (typically 13.28 to 13.46 depending upon the mold)

The dry unit weight is subsequently computed using Equation 6.2.

(6.2)

$$\gamma_d = \frac{\gamma_w * 100}{MC + 100}$$

Where,

γ_d = dry unit weight, pcf

MC = moisture content, %

The research team used dry unit weight for creating the family of curves for several reasons. First, the entire premise of using moisture unit weight relations correlates dry unit weight with moisture content, therefore, we plotted the curves as dry unit weight curves as they were a function of the moisture content. Second, the terminology and use of “wet” densities for compaction testing has substantially been reduced since the SDDOT adopted the use of the family of curves method. Third, the term use is not technically a wet unit weight implying saturation, it is a total unit weight implying the material has some moisture content; as such, moist (total) unit weight does not correlate with moisture content in terms of compaction. Fourth, AASHTO T 272-15 Standard Method of Test for Family of Curves-One-Point Method specifies the use of a family of curves using dry unit weight rather than “wet” unit weight. This method was followed

during the construction of the new family of curves. Fifth, SDDOT method 104 specifies the use of dry unit weight. Note that all terms should technically be “unit weight”, not “density”, however those terms are commonly used interchangeably.

Although the Ohio Highway Department’s Typical Family of Curves are presented as “wet” unit weight curves, each curve is based on a correlation to a maximum dry unit weight and optimum moisture content. The research team supported by the literature found this to be confusing and misleading, and could lead to misinterpretation of the curves and errors. Therefore, dry unit weight curves were selected to be used for the new curves.

The use of this new family of compaction curves may help alleviate problems comparing field in-situ density tests to target densities obtained from the one-point method. This is because the new set of curves provides an expected maximum dry density and optimum moisture rather than providing a fitted curve. The SDDOT Base and Subbase Moisture Density Curves depend on the laboratory determination of maximum dry unit weight and optimum moisture to plot within a region defined between two curves. Within each region, an average maximum dry unit weight and OMC was determined. This average maximum dry unit weight and OMC was determined by averaging all the encountered laboratory moisture density curves in each region or increment as it is referred to in Chapter 3. If the SDDOT decides to use this new family of compaction curves they may have less tendency to over predict maximum dry density of South Dakota base and subbase materials. This would likely save the SDDOT considerable time and cost on projects by reducing the amount of time needed to compact granular materials. The following is a summary of a theoretical example of the recommended new SDDOT Base and Subbase Moisture Density Curves in practice:

- A base course sample has been determined to be granular through a sieve analysis,
- A portion of the sample is compacted and the “1-point determination” for dry density is determined to be 134.0 pcf and a moisture content of approximately 7.6 percent,
- Entering the SDDOT Base and Subbase Moisture Density Curves, the point plots in the region defined by curve D and Curve E as presented in

SDDOT Base and Subbase Moisture-Density Curves (Base Course and Subbase Granular Materials)

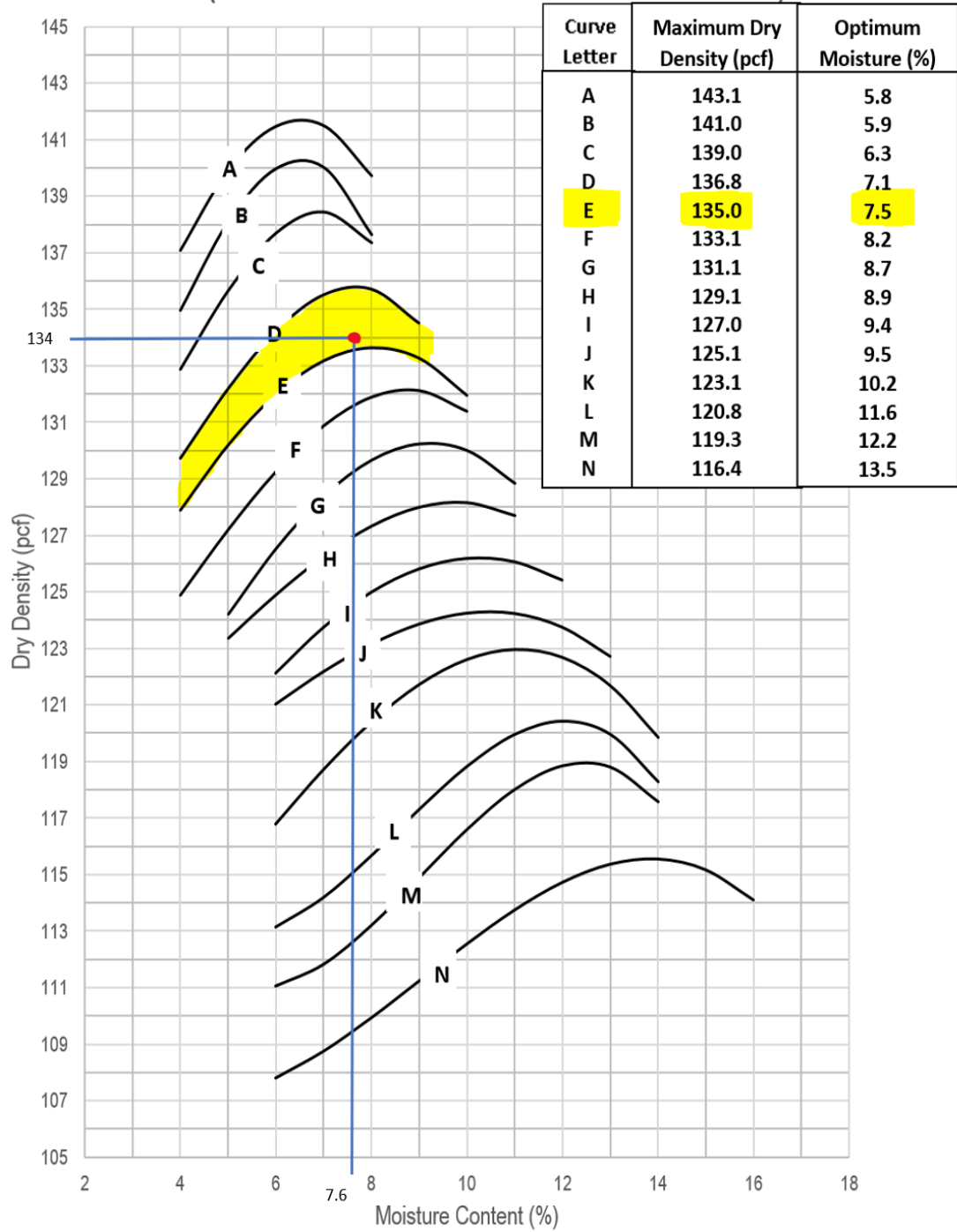

Figure 32,

- The point does not plot directly on either curve, therefore the curve below the point is selected, curve E,

- According to the table in the upper right-hand corner of

SDDOT Base and Subbase Moisture-Density Curves (Base Course and Subbase Granular Materials)

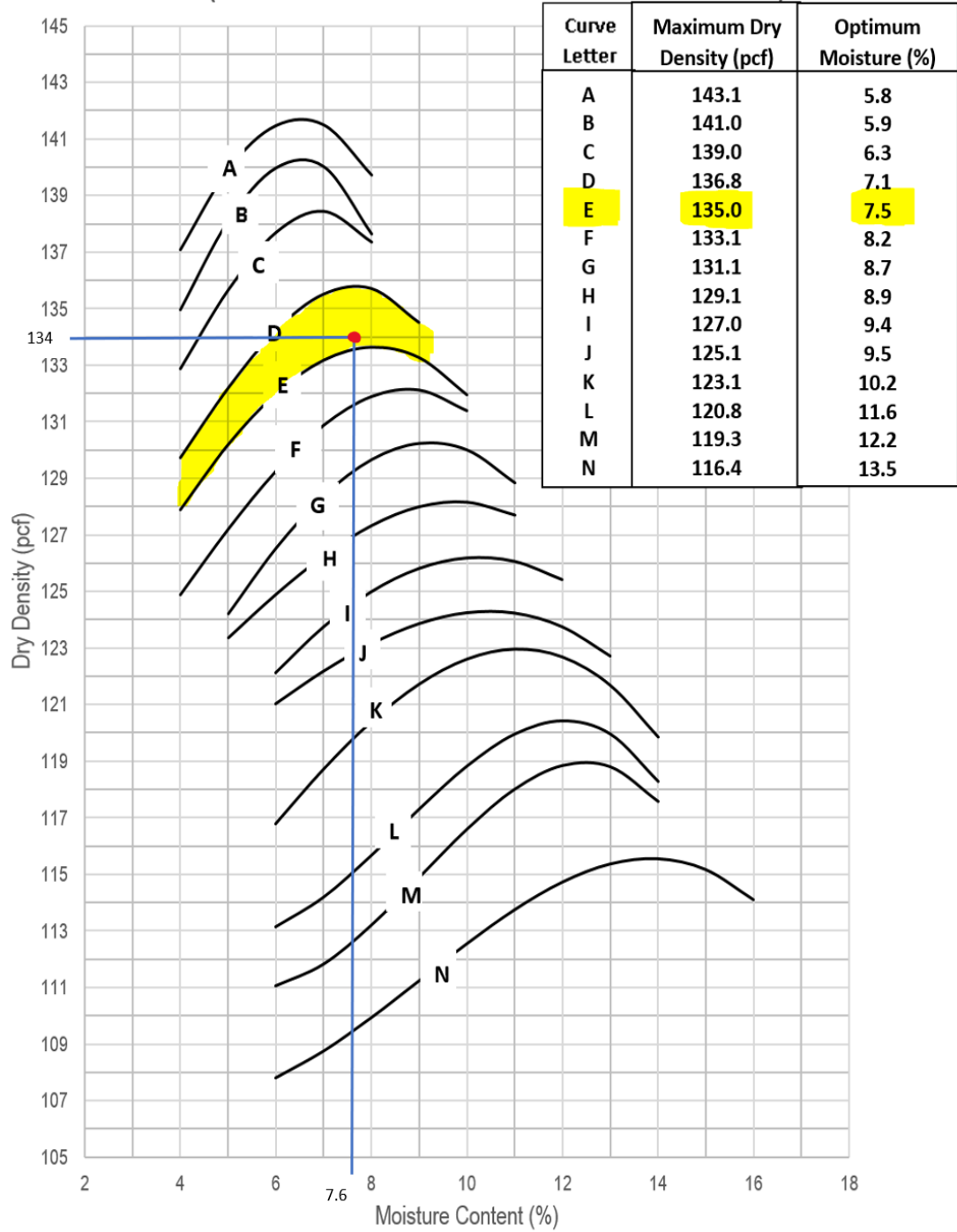

Figure 32 the predicted “target” maximum dry density and optimum moisture are 135 pcf and 7.5 percent. These values will be used as the target values for field testing.

SDDOT Base and Subbase Moisture-Density Curves (Base Course and Subbase Granular Materials)

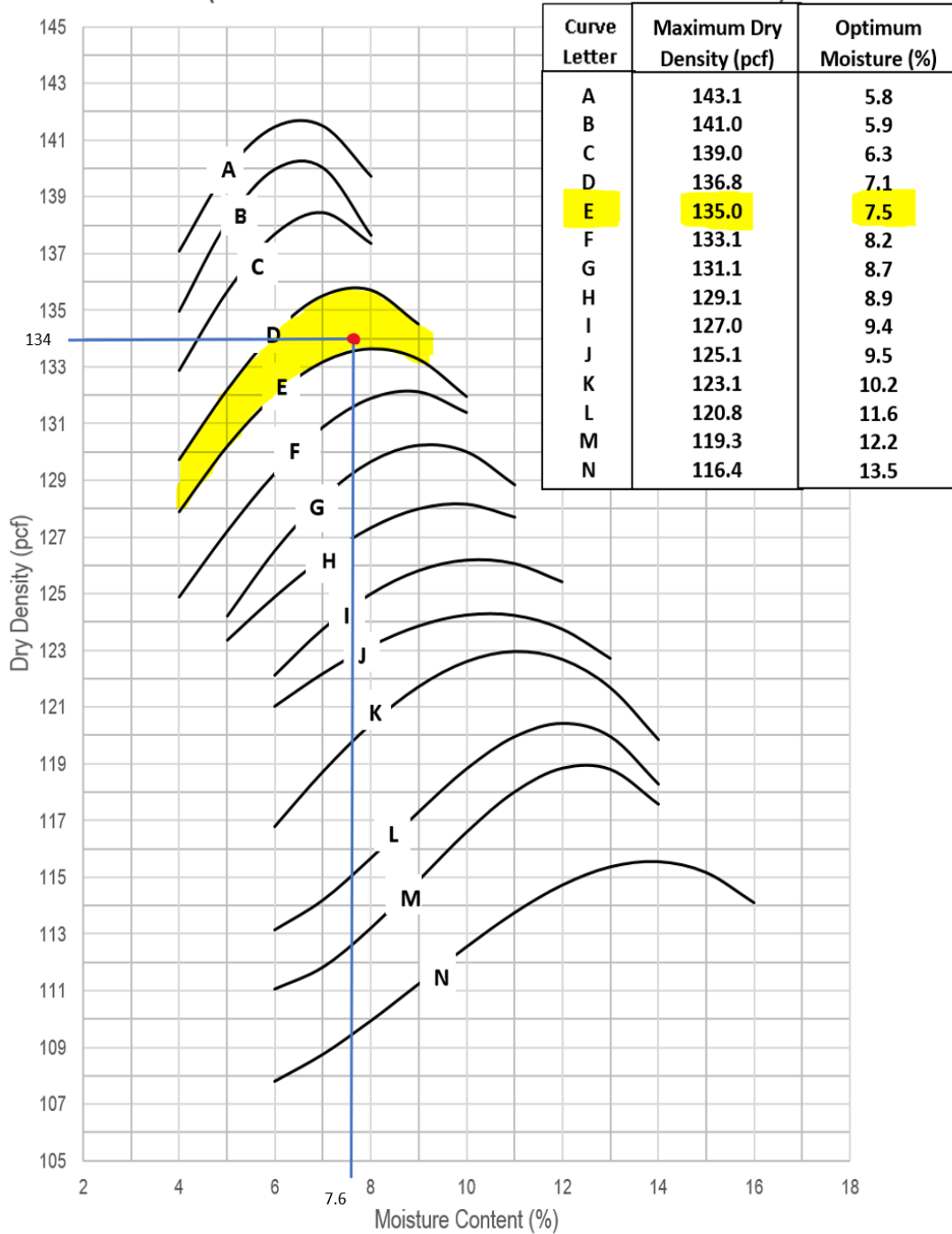

Figure 32: The plotted example using the SDDOT Moisture Density Curves.

6.2 The Dynamic Cone Penetrometer

The research team recommends that the SDDOT use the DCP for compaction quality control of granular base and subbase materials as well as milled, reclaimed, salvaged, and FDR materials all with maximum particle size of less than or equal to 1.5 inches.

The DCP was determined to be the most desirable alternative to current density-based granular compaction quality control. The device was well documented in the literature review and can be correlated to the CBR and resilience modulus of various material types. These correlations were presented in Section 2.4.5. The DCP costs much less than other alternatives with a price to own at approximately \$1,500 per device. Cost estimates for the implementation of the DCP device are present in Section 5.4. The DCP when properly implemented, could save project inspectors considerable time and result in increased efficiency of field compaction quality control.

This research has presented two methods for compaction quality control using the DCP. A method was presented for determining adequate compaction of base and subbase granular materials with a maximum particle size of less than or equal to 1.5 inches. The second method is intended to be utilized with milled, reclaimed, salvaged and FDR materials with a maximum particle size of less than or equal to 1.5 inches. These methods were developed to be similar to methods already being used with success in other DOT's and are presented in Appendix A.

6.3 Implementation Plan

It is recommended that the SDDOT implement the New SDDOT Base and Subbase Moisture Density Curves and the methods proposed for the Dynamic Cone Penetrometer (DCP) using an incremental approach as applied to a pilot study.

The implementation of the SDDOT Base and Subbase Moisture Density Curves and the methods proposed for the Dynamic Cone Penetrometer (DCP) can be approached incrementally using a pilot study. The approach is outlined as follows:

- Both new methods should be assessed individually side-by-side with existing SDDOT methods for evaluating compaction. This will allow for the SDDOT to evaluate which methods work best in

achieving their field quality control goals. This will also identify any potential problems with the recommendations that may need to be addressed before full implementation.

- The pilot project should be a project that requires comparison with at least 30 test points. The project should include granular base / subbase granular materials. Note that for projects that use recycled materials, the same number of points should initially be used for assessing these types of materials.
- The pilot study inspectors and engineers should perform current compaction test methods for the various materials encountered alongside the new methods. They should then perform the recommended test methods using the SDDOT Base and Subbase Moisture Density Curves and the DCP. The various test methods should all be conducted within a 5 foot radius to ensure that test results are from similarly compacted materials. The results of the tests should then be compared considering time and cost.
- The results of the currently used Ohio Highway Department's Moisture Density Curves should also be compared with the results of the recommended SDDOT Base and Subbase Moisture Density Curves. The SDDOT should compare the laboratory compaction test results with the target density and OMC determined from each family of compaction curves. The family of compaction curves that determine target density and OMC closest to the laboratory compaction test results will be the more desirable family of compaction curves. The results of the density-based in-situ tests methods should be compared to the acceptable PIV values recommended for each method. This comparison will ensure that the specified acceptable PIV values correlate to adequate levels of compaction for South Dakota granular materials. The acceptable PIV values may need to be adjusted depending on the results.
- Finally, based on the comparison results, the SDDOT can then implement the methods, procedures, and specifications into their Construction and Specification manuals. This will include purchase of DCP equipment and training project inspectors and engineers. Training should include the fundamentals and use of the DCP device (various components and assembly for job site use). The training would also present the methods, procedures and specifications to project engineers

and how those results would be used to evaluate acceptance of compacted granular materials.

Various costs for implementation are presented in Section 5.4.

7.0 RESEARCH BENEFITS

Potential implementation of the SDDOT Base and Subbase Moisture Density Curves may decrease the time required to obtain target density and OMC associated with assessing compacted granular materials. These compaction curves have been developed using the same granular base and subbase materials encountered in the field by the SDDOT. This may lead to better approximations in achieving acceptable percentages of the target density when conducting in-situ field testing. The process of over compacting granular material can add considerable time to the compaction process and increase the budget.

The cost savings and test time efficiency of the using the recommended DCP test methods are the main benefits of the research. The implementation of the DCP would eliminate laboratory standard compaction tests after pilot studies have been completed and assessed. The DCP method would also reduce the reliance of the NDG for the compaction verification of base and subbase granular material. The NDG has strict regulations due to radioactive components. These regulations increase the yearly cost to own and operate the device estimated at approximately \$9400/year/device. The DCP will only require replacement of cone tips, a much lower yearly maintenance cost. This should decrease the cost of compaction verification of granular materials.

The time required to perform a test using the DCP test methods takes approximately 2 minutes to complete.

The current methods for testing granular materials used by the SDDOT depend on determining target dry density and OMC. It may take over an hour to construct a single 4-point standard moisture density curve to verify the use of the Ohio Highway Department's Typical Moisture Density Curves. Then it takes additional time to conduct a 1-point standard moisture density determination to obtain a target density and OMC. The SDDOT has stated that often when conducting these methods, project inspectors experience delays in verification of the compacted granular material. The DCP would greatly reduce these inefficiencies and simplify the verification process.

The DCP measures the soils resistance to penetration which is directly related to the resilience modulus of the material. The correlations presented in this report can be used to link the design criteria used during mechanistic-empirical pavement design to the construction compaction verification process. This is unlike the current density-based methods that lack a direct link to the design process of the

pavement. Implementing the DCP would familiarize project inspectors and engineers to the benefits of stiffness / strength-based compaction verification.

Appendix A: Prepared Procedures, Methods, and Supplemental Specifications

Determination of the Penetration Index Value for Granular Material In-place by the Dynamic Cone Penetrometer Test Methods

1. Scope:

The methods presented are for determining the in-place Penetration Index Value (PIV) for granular material with a maximum particle size of ≤ 1.5 inches. PIV values are used to assess adequate compaction of granular materials. Two methods are presented for different specified material types.

Definitions.

Compaction: The use of equipment to compress soil, aggregate, or mixture into a smaller volume, thus increasing its dry unit weight and improving its engineering properties; strength and stability.

Dynamic Cone Penetrometer (DCP): The device utilized to determine the in-place Penetration Index Value of granular material layers. The device apparatus within this Method and within the SD ### (DCP Procedure). The procedure for using the device is outlined in detail in SD ### (DCP Procedure).

Penetration Index Value (PIV): The measurement obtained during testing utilizing the DCP. The measurement is the amount of penetration per blow and is calculated in increments of 3 blows. The measurement is recorded in units of mm/blow or inches/blow. The calculation is the reading on the DCP measurement rod in mm or in. after 3 standard test blows minus the reading prior to the standard test blows divided by the 3 standard test blows. This measurement can be correlated to various laboratory strength test such as the California Bearing Ratio Test.

$$\text{PIV} = \frac{\text{Reading after 5 blows} - \text{Reading after 2 blows}}{3}$$

SEAT: The SEAT refers to the initial seating of the DCP cone tip. This requires two initial standard blows. The SEAT is the measurement of penetration measurement in mm or in. after the two initial blows.

2. Apparatus:

2.1 The 17.6-lb (8-kg) DCP is shown schematically in Figure 1 with replaceable cone schematic shown in Figure 2. It consists of the following components: a 16-mm (5/8-in.) diameter steel drive rod with a replaceable point, a 17.6-lb (8-kg) rammer which is dropped from a fixed height of 575 mm (22.6 in.). The apparatus is typically constructed of stainless steel, with the exception of the replacement point tip, which may be

constructed from hardened tool steel or a similar material resistant to wear.

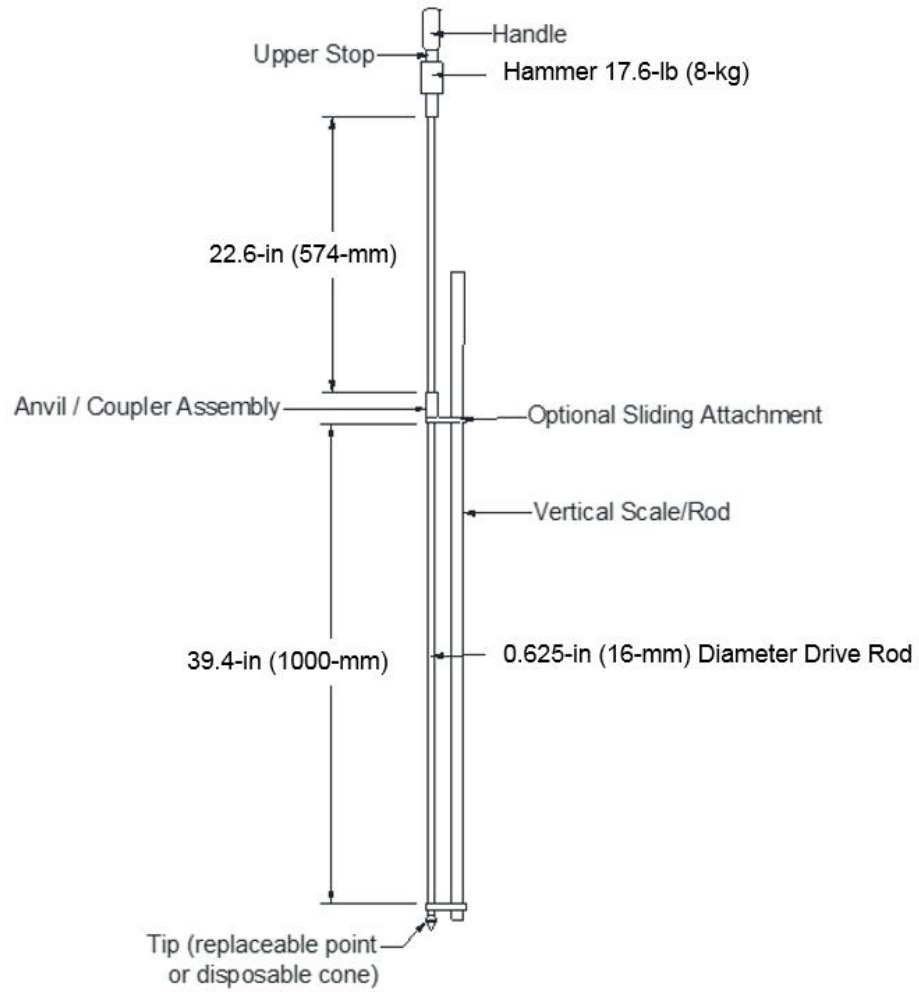

Figure 1 Schematic of DCP

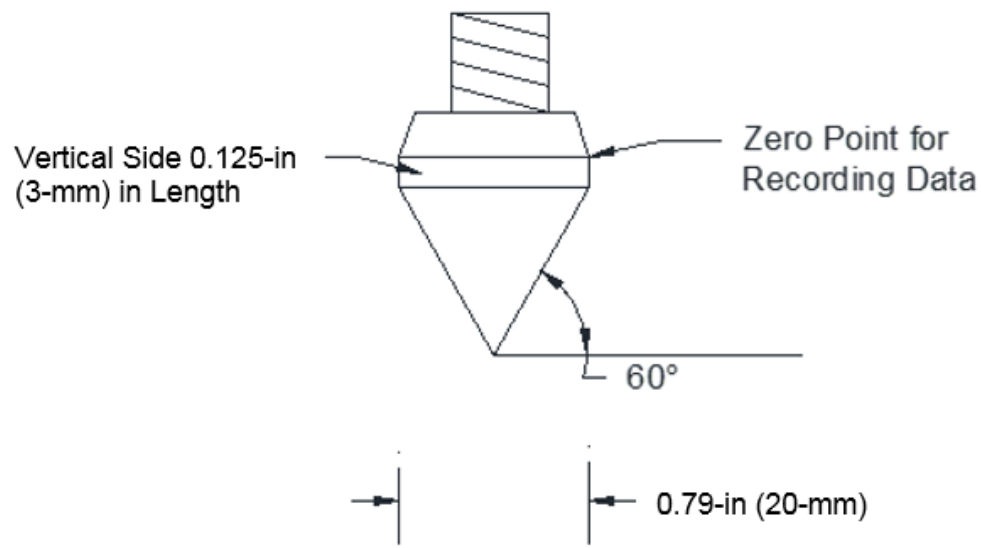

Figure 2. Replaceable Point Tip

- 2.2 The following tolerances are recommended for the apparatus: Hammer weight-measurement of 17.6-lb (8.0-kg); tolerance is 0.02-lb (0.01-kg), Drop of rammer-measurement of 575 mm (22.6 in.), tolerance is 1.0 mm (0.04 in.), Tip angle measurement of 60 degrees included angle; tolerance is 1 degree, and Tip base diameter measurement of 20 mm (0.79 in.); tolerance is 0.25 mm (0.01 in.).
- 2.3 In addition to the DCP, the following equipment is needed: Tools for assembling the DCP, Lubricating Oil, Thread Locking Compound, and PIV Data Worksheet for recording data (See Attached).
- 2.4 Depending on the circumstances, the following equipment may also be needed or is recommended: A vertical scale graduated using increments of 1.0 mm (0.04 in.), or measuring rod longer than the longest drive rod if the drive rod(s) are not graduated, an optional sliding attachment for use with a separate scale or measuring rod, and extraction jack. The extraction jack can be seen in Figure 3 below.

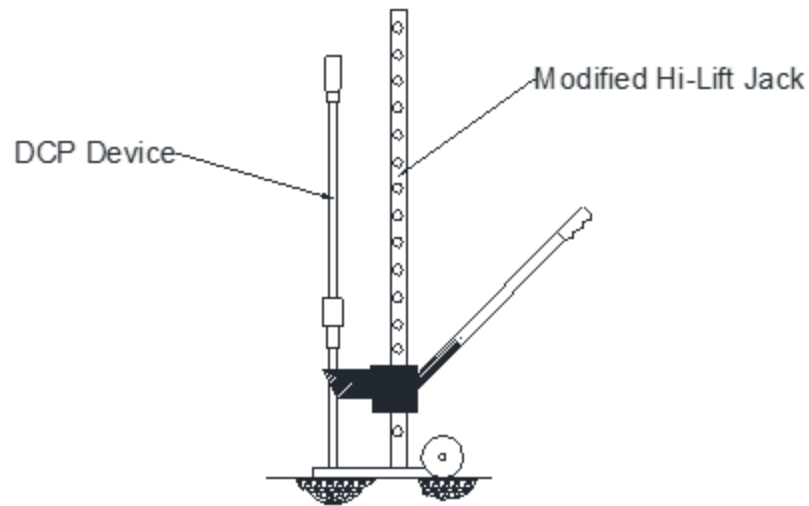

Figure 3 Optional Extraction

3. Procedure:

- Method 1 For testing virgin aggregate that meets the specific requirements of Subbase, Base Course, Gravel Cushion, and Gravel Surfacing as specified by Section 882.2 of SDDOT Standard Specifications for Roads and Bridges.
- Method 2 For testing salvaged materials that meet the specific requirements of Milled and Reclaimed as specified by Section 884.2 of SDDOT Standard Specifications for Roads and Bridges. This method is also used when testing Full Depth Reclamation (FDR) asphalt. This method may also be used for materials classified by the SDDOT Standard Specifications for Roads and Bridges as recycled materials.

3.1 Method 1 (Subbase and Base Course)

- A. Obtain most recent Sieve Analysis (DOT-3) results for granular material being tested to determine Grading Number (GN). If a sieve analysis has not been previously conducted for the material, conduct a sieve analysis in accordance with SD 202 to obtain results for the GN determination. The analysis shall include the following sieve sizes: 1", 3/4", 3/8", #4, #10, #40, #200. Record the percent passing each sieve and sample ID on DCP Penetration Index Value Worksheet Method 1 under Gradation Data.
- B. Calculate the GN to determine SEAT and PIV test acceptance requirements. The GN is calculated by summing the percent passing each of the sieves shown below and dividing the sum by 100. Record GN on DCP Penetration Index Value Worksheet Method 1 under Gradation Data.

$$(\text{GN}) = \frac{1" + 3/4" + 3/8" + \#4 + \#10 + \#40 + \#200}{100}$$

- C. Determine the Moisture Content (MC), SEAT, and PIV test acceptance requirements for the calculated GN.

Table 1: SEAT and PIV requirements.

Grading Number	MC (%)	Maximum Allowable Seating (mm)	Maximum Allowable PIV (mm/blow)	Grading Number	MC (%)	Maximum Allowable Seating (mm)	Maximum Allowable PIV (mm/blow)
3.1 – 3.5	< 5.0	40	10	4.6 – 5.0	< 5.0	65	15
	5.0 – 8.0	40	12		5.0 – 8.0	75	19
	> 8.0	40	16		> 8.0	85	23
3.6 – 4.0	< 5.0	40	10	5.1 – 5.5	< 5.0	85	17
	5.0 – 8.0	45	15		5.0 – 8.0	95	21
	> 8.0	55	19		> 8.0	105	25
4.1 – 4.5	< 5.0	50	13	5.6 – 6.0	< 5.0	100	19
	5.0 – 8.0	60	17		5.0 – 8.0	115	24
	> 8.0	70	21		> 8.0	125	28

- D. Equipment Check: Before beginning a test, the DCP device shall be inspected for fatigue-damaged parts, in particular the coupler and handle, and excessive wear of the drive rod and replacement point tip. All joints must be securely tightened including the coupler assembly and the replaceable point tip (or the adapter for the disposable cone tip) to drive rod.
- E. Locate a level, undisturbed area.
- F. To determine the in-situ material SEAT and PIV perform the test in accordance with SD ### (DCP Test Procedure).
- G. Record test results on DCP Penetration Index Value Worksheet Method 1 (DOT- ##). If test results do not meet test acceptance requirements, moisture condition the material and compact again before conducting another test.
- 3.2 Method 2 (Milled, Reclaimed, Salvaged, and FDR)
- A. Equipment Check: Before beginning a test, the DCP device shall be inspected for fatigue-damaged parts, in particular the coupler

and handle, and excessive wear of the drive rod and replacement point tip. All joints must be securely tightened including the coupler assembly and the replaceable point tip (or the adapter for the disposable cone tip) to drive rod.

- B. Locate a level, undisturbed area.
- C. To determine the in-situ material SEAT and PIV perform the test in accordance with SD ### (DCP Test Procedure).
- D. Record test results on DCP Penetration Index Value Worksheet Method 2 (DOT - ##). If the SEAT value exceeds 20 mm (0.80 in.) relocate to the test site at least 300 mm (12 in.) from previous test site and reseal the cone. If the second test site fails the above criteria, compaction is not acceptable, and the area being tested shall be moisture conditioned and compacted again. If the resulting PIV is 15 mm/blow or less, the test passes.

4. Report:

4.1 Calculations.

A. Grading Number (GN)

$$(GN) = \frac{1" + \frac{3}{4}" + \frac{3}{8}" + \#4 + \#10 + \#40 + \#200}{100}$$

Where the percent passing each sieve is used.

B. SEAT value:

$$SEAT = A - B$$

where:

A = DCP penetration reading after 2 standard blows in mm or inches.

B = DCP penetration reading before 2 standard blows in mm or inches.

SEAT= DCP Seating value in mm or inches.

C. Penetration Index Value (PIV):

$$PIV = \frac{A - B}{3}$$

Where:

A = DCP penetration reading after 5 standard blows in mm or inches.

B = DCP penetration reading after 2 standard blows in mm or inches.

PIV = Penetration Index Value in mm/blow or inches/blow.

4.2 Report.

- A. Report the moisture content to the nearest 0.1 percentage point.
- B. Report the SEAT value to the nearest 0.1 mm.
- C. Report the PIV value to the nearest 0.1 mm/blow.
- D. Provided required information on the DCP Penetration Index Value Worksheet.

5. References:

ASTM D6951

DOT - 3

DOT - ## (DCP Penetration Index Value Worksheet Method 1)

DOT - ## (DCP Penetration Index Value Worksheet Method 2)

SD 108

SD ### (DCP Procedure)

Determination of the Penetration Index Value for Granular Material In-place by the Dynamic Cone Penetrometer Test Procedure

1. Scope:

This test is for determining the in-place Penetration Index Value (PIV) for granular material with a maximum particle size of ≤ 1.5 inches and have a non-compacted layer thickness of 6" or less. PIV values are used to assess adequate compaction of granular materials.

2. Apparatus:

2.1 The 17.6-lb (8-kg) DCP is shown schematically in Figure 1 with replaceable cone schematic shown in Figure 2. It consist of the following components: a 16-mm (5/8-in.) diameter steel drive rod with a replaceable point, an 17.6-lb (8-kg) rammer which is dropped a fixed height of 575 mm (22.6 in.). The apparatus is typically constructed of stainless steel, with the exception of the replacement point tip, which may be constructed from hardened tool steel or a similar material resistant to wear.

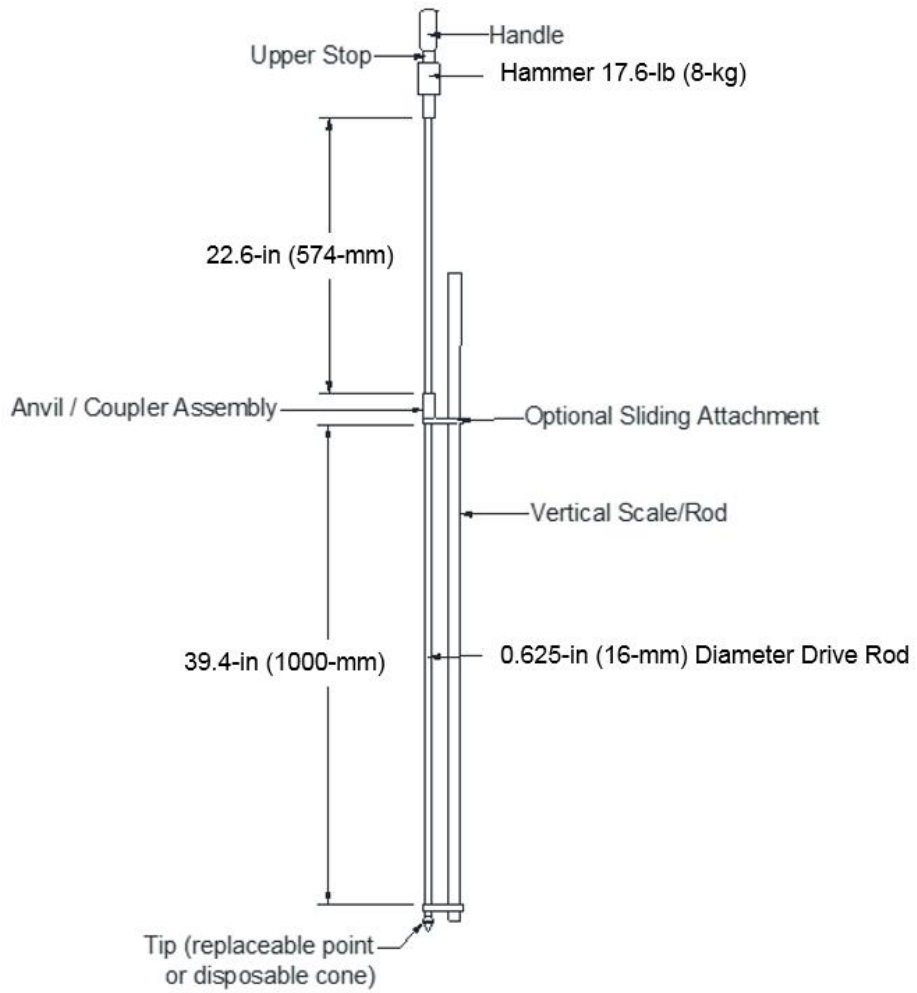

Figure 1 Schematic of DCP

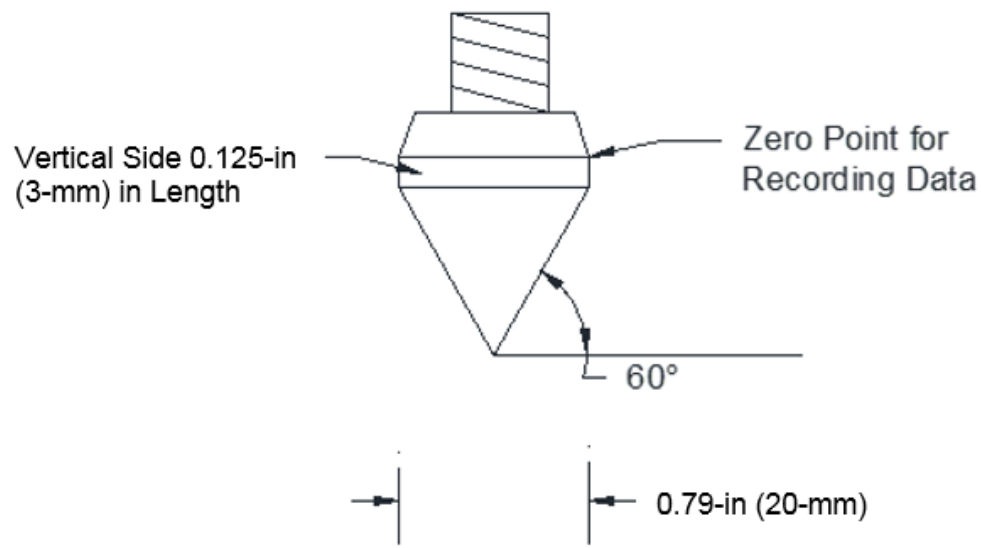

Figure 2. Replaceable Point Tip

- 2.2 The following tolerances are recommended for the apparatus: Hammer weight-measurement of 17.6-lb (8.0-kg); tolerance is 0.02-lb (0.01-kg), Drop of rammer-measurement of 22.6-in (575-mm), tolerance is 0.04 in (1.0-mm), Tip angle measurement of 60 degrees included angle; tolerance is 1 degree, and Tip base diameter measurement of 0.79-in (20-mm); tolerance is 0.01-in (0.25-mm).
- 2.3 In addition to the DCP, the following equipment is needed: Tools for assembling the DCP, Lubricating Oil, Thread Locking Compound, and PIV Data Worksheet for recording data (See Attached).
- 2.4 Depending on the circumstances, the following equipment may also be needed or is recommended: A vertical scale graduated using increments of 0.04-in (1.0-mm), or measuring rod longer than the longest drive rod if the drive rod(s) are not graduated, An optional sliding attachment for use with a separate scale or measuring rod, and Extraction jack. The extraction jack can be seen in Figure 3 below.

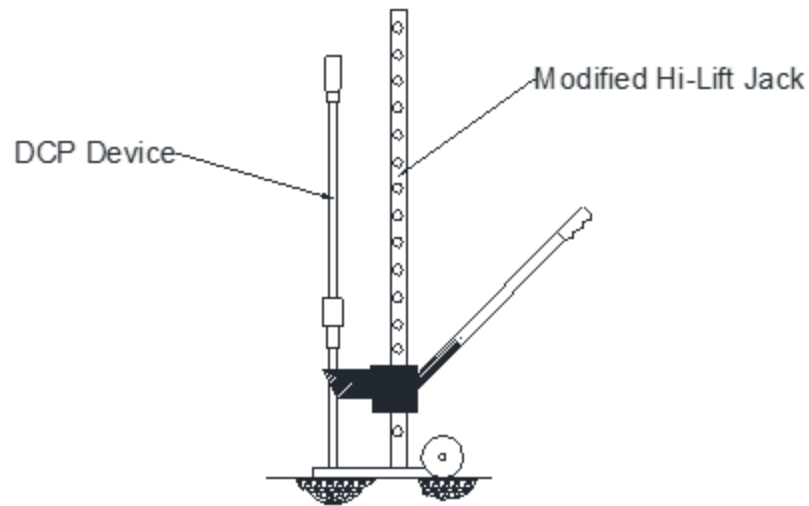

Figure 3 Optional Extraction

3. Procedure:

3.1 Basic Operation

- A. The operator holds the device by the handle in a vertical position and lifts and releases the rammer from the standard drop height. The recorder measures and records the total penetration for a given number of blows or the penetration per blow. A single operator can perform both tasks concurrently if required.

3.2 Equipment Check

- A. Before beginning a test, the DCP device shall be inspected for fatigue-damaged parts, in particular the coupler and handle, and excessive wear of the drive rod and replacement point tip. All joints must be securely tightened including the coupler assembly and the replaceable point tip (or the adapter for the disposable cone tip) to drive rod.

3.3 Initial Reading and Seating for Testing Granular Materials

- A. Locate a level, undisturbed area.
- B. The DCP is held vertically and the tip seated such that the top of the widest part of the tip is flush with the surface of the material to be tested. Take an initial reading and record it on the PIV Worksheet. The distance is measured to the nearest 0.04-in (1-mm). Some sliding reference attachments allow the

scale/measuring rod to be set/marked at zero when the tip is at the zero point shown in Figure 2.

- C. Raise the rammer until it meets the handle, then release the rammer under its own weight and allow it to impact the anvil coupler assembly. Repeat this process one more time for a total of 2 initial drops to complete the seating process. The corresponding penetration is recorded on the PIV Data Worksheet. The distance is measured to the nearest 0.04-in (1-mm).

NOTE: The operator raises the rammer until it makes only light contact with the handle.

3.4 Testing Sequence.

- A. Carefully raise the rammer until it meets the handle, then release the rammer under its own weight. Repeat the process two more times for a total of five blows.
- B. Measure and record the final penetration measurement after 5 blows on the PIV Data Worksheet.
- C. The DCP is extracted from the test hole. An extraction jack may be used to aid in this process.
- D. Collect a representative sample from the test hole for a moisture content determination. Weigh the material to the nearest 0.1 g and dry it to a constant weight as per SD 108. Record the moisture content on the PIV Data Worksheet.

NOTE: The presence of large aggregates or rock strata will either stop further penetration or deflect the drive rod. If after 5 blows, the device has not advanced more than 0.08-in (2-mm) or the handle has deflected more than 3-in (75-mm) from the vertical position, the test shall be aborted and the device moved to another test location. The new test location shall be a minimum of 12-in (300-mm) from the prior location to minimize test error.

4. Report:

4.1 Calculations

- A. The SEAT measurement is calculated by subtracting the initial reading from the reading after 2 blows.

- B. The PIV value is a the reading obtained after 5 blows minus the reading after 2 blows divided by the number of blows (3) as seen in the equation below.

$$\text{PIV} = \frac{\text{Reading after 5 blows} - \text{Reading after 2 blows}}{3}$$

4.2 Report

- E. Report the moisture content to the nearest 0.1 percentage point.
- F. Report the SEAT value to the nearest 0.1 mm.
- G. Report the PIV value to the nearest 0.1 mm.
- H. Provided required information on the DCP Penetration Index Value Worksheet.

5. References:

ASTM D6951
SD 108

**STATE OF SOUTH DAKOTA
DEPARTMENT OF
TRANSPORTATION**

**SUPPLEMENTAL SPECIFICATIONS TO
2015 STANDARD SPECIFICATIONS FOR ROADS AND**

BRIDGES October 6, 2017

All items included in this Supplemental Specification will govern over the Supplemental Specifications for Errata.

MAKE THE FOLLOWING CHANGES TO THE INDICATED SECTIONS:

Section 260.3 B – Page 119 – Delete section and replace with the following:

In Section B:

Subbase and Base Course: Each layer shall be compacted to the specified Penetration Index Value PIV and DCP seating requirements before the next lift is placed and shall be rolled until a uniform and stable surface is obtained. The requirements for acceptance are specified according the materials Grading Number (GN) as described in SD ### (DCP PIV Method 1). In-situ tests shall be conducted in accordance with SD ### (DCP Procedure).

Section 260.3 C – Page 119 – Delete section and replace with the following:

In Section C:

Subbase, Salvaged and Base Course, Salvaged: Each layer shall be compacted to obtain a Penetration Index Value (PIV) of 15 mm/blow or less and shall not have a SEAT in excess of 20 mm. Test shall be conducted in accordance with SD ### (DCP Procedure) and SD ### Method 2 (DCP Methods).

1. Material shall have a minimum of 4% moisture uniformly blended throughout the depth of the lift of material. The percent moisture may be adjusted by the Engineer.

Section 280.3 C – Page 124 – Delete section and replace with the following:

In Section C:

Compaction Requirements: The entire lift shall be compacted to obtain Penetration Index Values (PIV) of 15 mm/blow or less. The lift shall not have a SEAT Value more than 20 mm. The Entire lift shall be tested in accordance with SD ### (DCP Procedure) and SD ### Method 3 (DCP Methods).

1. Material shall have a minimum of 4% moisture uniformly blended throughout the depth of the lift of material. The percent moisture may be adjusted by the Engineer.

*

*

Moisture-Density Relations of Soils, Aggregates, and Specified Mixtures

1. Scope:

This test is to establish the moisture-density relationship of soils, aggregates and mixtures.

NOTE: Before field control of compaction can be exercised, it is required that the optimum moisture, maximum density values (4-point Method) be determined for the materials prior to, or at the time field compactions are measured.

The purpose of the 4-point determination is to verify if a family of curves is usable for the material. Changing from one family of curves to the other family of curves requires a 4-point determination to validate the change.

Definitions.

Compaction: The act of increasing the unit weight of the soil, aggregate or mixture, by mechanically compressing the material into a closer state of contact. For a given compaction effort, the density of the material tested will normally increase until optimum moisture content is reached, then the density will begin to decrease. It should be noted that there have been cases where the apparent decrease in density was followed by another increase in density. These secondary or "False" plateaus in the moisture-density curve should always be checked to determine the valid data.

The Percent Compaction: This is the ratio of the density of the material, as placed during construction, to the maximum density of a representative specimen of the same material.

Density: The density of a material is the weight per unit volume, in lbs./ft³ in dry condition.

One-Point (Standard) Test: A rapid test where the wet density or dry density and moisture content measurements for the test material are used to select a curve from a family of curves to be the standard.

Four-Point (Standard) Test: The results of four or more moisture-density tests are plotted with density values as the ordinate or vertical scale and the moisture content (Percentage) as the abscissas or horizontal scale. When the plotted points are joined by a smooth curve, the maximum density at optimum moisture may be determined. (Figure 2, 3, 7 and 8) The moisture content corresponding to the peak of the curve shall be termed "Optimum Moisture" of the material. The dry density in lbs./ft³ at optimum moisture content shall be termed the "Maximum Density".

Optimum Moisture: The moisture content corresponding to the maximum density.

Maximum Density: The highest value for density, calculated on the basis of dry weight of material per cubic foot, shown on the moisture density curve.

2. Apparatus:

2.1 Molds. A 4" diameter or 6" diameter mold meeting the requirements of AASHTO T 99.

2.2 Rammer. A 5.5 lb. rammer conforming to AASHTO T 99.

NOTE: A mechanical rammer may be used, if approved by the Chief Materials and Surfacing Engineer.

2.3 Sample extruder (Optional) such as a jack, frame, or other device adapted for extruding compacted specimens from the mold.

2.4 Scale or balance having the capacity to weigh any sample which may be tested utilizing this procedure and readable to the nearest 0.01 lb. and also one that is readable to the nearest 0.1 gram.

2.5 Sieves and screens. A 3/4" and a #4 sieve. A #4 rough screen shall be approximately 12" x 18" in size. #4 sieves intended for use in sieve analysis testing shall not be used for pushing wet material through as shown in paragraph 3.2 B.

2.6 Oven.

A. An oven, for determining moisture content, capable of maintaining a temperature of $230^{\circ} \pm 9^{\circ}\text{F}$.

B. An oven for drying soil samples at a temperature not exceeding 140°F .

NOTE: Other methods of moisture determination shown in SD 108 may be used.

2.7 Containers for moisture content samples.

2.8 Steel straightedge at least 12" in length.

2.9 Miscellaneous: Tools, plastic bags, beakers, cans, pails, shovel, spatula, knife, spoons and trowel.

3. Procedure:

Method 1 Four Point - For testing materials passing a #4 sieve using a 4" mold. Method 2 One Point - For testing material passing a #4 sieve using a 4" mold. Method 3 Four Point - For testing material passing a 3/4" sieve using a 6" mold. Method 4 One Point - For testing material passing a 3/4" sieve using a 6" mold.

NOTE: The method used for determining the 4-point will establish the method used for the 1-point, i.e., if the 4" mold is used for the 4-point, (Method 1) the 4" mold must be used for the 1-point (Method 2). If it is requested to change mold size, a 4-point using that size mold must be completed. The mold without the collar shall be weighed to the nearest 0.01 lb., prior to beginning the test.

3.1 Method 1 (Soil).

- A. Obtain a sample of soil weighing approximately 30 lbs.
- B. Dry the sample in an oven at a temperature not exceeding 140°F.
- C. Using the apparatus described in SD 101, break the sample down to pass the #4 sieve. Care must be taken not to break any rock retained on the #4 sieve. Sieve the sample on a #4 sieve and discard any granular material retained.
- D. Reduce the sample to 5 specimens, weighing approximately 5 lbs. each.
- E. Thoroughly mix one of the specimens with a measured amount of water to dampen it to approximately 4 to 6 percentage points below optimum.
- F. Place the specimen in a plastic bag and seal the top to prevent moisture loss. Allow the specimen to cure for a minimum of 12 hours.
- G. Mix the remaining specimens in the same manner as shown in paragraphs E. and F., increasing the measured water by approximately 2 percentage points over the preceding specimen. The percent of increase should be at a uniform rate.
- H. The test specimen is then formed in the 4" mold, with collar attached, in three approximately equal layers, to a total

compacted depth of approximately 5". Compact each layer using 25 uniformly distributed blows from the rammer dropping free from a height of 12" above the surface of the soil in the mold. Clean rammer head prior to compacting the next layer to ensure the calibrated rammer head is still 5.5 lbs.

NOTE: During compaction, the mold shall rest firmly on a dense, uniform rigid and stable foundation. The following are satisfactory as a base on which to rest the mold during compaction: a block of concrete weighing at least 200 lbs., a sound concrete floor, concrete box culverts, bridges and PCC pavement.

- I. Immediately following compaction, remove the extension collar, carefully trim the compacted material even with the top edge of the mold with a knife and straightedge. Holes in the surface of the molded material caused by removal of coarse particles shall be patched with finer material removed in trimming.

Weigh the mold and compacted moist specimen in lbs. to the nearest 0.01 lb. Record the weight on the DOT-40 as "Weight of mold and wet specimen".

- J. Remove the moist specimen from the mold, slice vertically through the center of the specimen and take a representative sample from one of the cut faces for moisture determination.

Weigh a moisture test specimen of at least 100 g to the nearest 0.1 g and dry in an oven at $230^{\circ} \pm 9^{\circ}\text{F}$ to a constant weight as per SD 108.

Other methods of moisture determination shown in SD 108 may be used.

- K. After drying, weigh and record the weight of the moisture samples to the nearest 0.1 gram.
- L. Test each of the remaining specimens, as shown in paragraphs H. thru K.

NOTE: Continue this series of determinations until there is either a decrease or no change in the wet unit weight per cubic foot. If the plotted points of either the dry density or wet density do not form a curve, additional determinations will be performed to form the curve.

- M. Complete the calculations on the DOT-40 as shown in figure 1.
- N. Results of the calculations (Moisture content and corresponding wet and dry densities) are plotted on the graph (DOT-40) using density values as ordinates and moisture contents as abscissas. Draw a smooth curve connecting the points established by plotting results of four or more tests, figure 2 & 3.

The moisture content corresponding to the peak of the dry density curve shall be termed "Optimum Moisture" for the compacted material.

- O. The dry unit weight density lbs./ft³ of the compacted material at optimum moisture content shall be termed "Maximum Density".
- P. Validation of the family of curves: Prior to using any family of pre- drawn curves, it shall be checked using project material and the 4- point system. This can be done by comparison of wet density curves.
 1. Determine the maximum dry density and optimum moisture from the 4-point dry density curve. This should be at the peak of the dry density curve.
 2. Select a moisture content 1 1/2 to 2 percentage points below optimum moisture.
 3. Using this moisture content, find the corresponding wet density on the wet density curve of the 4-point.
 4. Plot this wet density and moisture content on the family of curves proposed for use on the project to determine the curve to be used for the standard.

Select the curve nearest the plotted point. If the plotted point is between 2 curves and there is doubt as to which curve is closest, use the curve below the plot.

The maximum dry density from this curve must be within 3 lbs. of the 4-point maximum dry density. If the curves fail to check within this tolerance, contact the Region Materials Engineer as the family of curves may not be reliable for this material.

3.2 Method 2 (Soil).

- A. Obtain a sample of approximately 5 lbs. of soil.
- B. Break up the sample using fingers, a trowel or a pine board to push the sample through a #4 rough screen.
- C. If the sample appears to be above optimum moisture, dry it sufficiently in an oven at a temperature not exceeding 140° F to bring it to approximately optimum.

If the sample appears too dry, add and mix sufficient water to bring it near optimum.
- D. Mold and take a moisture sample, as shown in paragraphs 3.1 H through 3.1 J. (Use form DOT-35 for moisture tests and DOT-41 for density tests.)

- E. Using the “1-point determination” wet density and the “1-point” moisture determination, enter the family of curves, figure 4 or figure 5, to obtain the maximum density and optimum moisture. The family of curves must be the one identified by the 4-point determination. (See “NOTE” on page 1 of this procedure.)

Select the curve nearest the plotted point. If the plotted point is between 2 curves and there is doubt as to which curve is closest, use the curve below the plot.

NOTE: If the 1-point moisture content deviates from optimum (for the curve selected) by more than 2 percentage points below or 1 percentage point above, a second 1-point shall be made at or nearer optimum and within the tolerance shown.

3.3 Method 3 (Soils / Granular Material).

- A. Obtain a sample of approximately 60 lbs. in accordance with SD 201.

NOTE: The tester may elect to obtain more material and mix individual samples at varying percentages of moisture. If so elected, follow the procedure shown in method 1 and obtain samples approximately 15 lbs. each and use a 3/4" sieve and a 6" mold.

- B. Dry the sample in an oven at a temperature not exceeding 140° F.
- C. Sieve the sample on a 3/4" sieve, discarding the material retained.
- D. Weigh the sample and add sufficient water to bring it to approximately 4 percentage points below optimum.
- E. The test specimen is then formed in the 6" mold in three approximately equal layers to a total depth of approximately 5". Compact each layer using 56 uniformly distributed blows from the rammer dropping 12" above the surface of the material in the mold. Clean rammer head prior to compacting the next layer to ensure the calibrated rammer head is still 5.5 lbs.

NOTE: During compaction, the mold shall rest firmly on a dense, uniform, rigid and stable foundation. The following are satisfactory bases on which to rest the mold during compaction: A block of concrete weighing at least 200 lbs., a sound concrete floor, concrete box culverts, bridges and PCC pavement.

- F. Immediately following compaction, remove the extension collar and carefully trim the compacted material even with the top edge of the mold with a straightedge. Holes in the surface of the molded material

caused by removal of coarse particles shall be patched with finer material removed in trimming.

Weigh the mold and compacted moist specimen in lbs. to the nearest 0.01 lb. Record on a DOT-40 as "Weight of mold and wet specimen".

- G. Remove the specimen from the mold, slice vertically through the center of the specimen and take a representative sample from one cut face for moisture determination.

Weigh a moisture test specimen of at least 100 grams for soil and 500 grams for granular material to the nearest 0.1 g and dry in an oven at a temperature of $230^{\circ} \pm 9^{\circ}\text{F}$ to a constant weight as per SD 108.

Other methods of moisture determination as shown in SD 108 may be used.

- H. After drying, weigh and record the weights of the moisture sample to the nearest 0.1 gram.
- I. Complete the calculation on the DOT-40 as shown in figure 6.
- J. Thoroughly break up the remaining portion of the specimen until it will pass a 3/4" sieve, and add it to the remaining portion of the sample being tested. Add sufficient water to increase moisture content of the sample between 1 and 2 percentage points and repeat the procedure in paragraphs 3.3 E. through 3.3 I.

NOTE: Continue this series of determinations until there is either a decrease or no change in the wet unit weight per cubic foot. If the plotted points of either the dry density or wet density do not form a curve, additional determinations will be performed to form the curve.

- K. Results of calculations (Moisture content and corresponding wet and dry densities) are plotted on the graph using density values as ordinates and moisture contents as abscissas. Draw a smooth curve connecting the points established by plotting results of 4 or more tests. (Figure 7 & 8).
- L. The moisture content corresponding to the peak of the dry density curve shall be termed "Optimum Moisture" for the compacted material.
- M. The dry unit weight corresponding to the peak of the dry density curve shall be termed "Maximum Density" of the compacted material.
- N. Prior to using any family of pre-drawn curves, it shall be checked, using project material and the 4-point system. This can be done by comparison of the dry density curves.

1. Determine the maximum dry density and optimum moisture from the 4-point dry density curve. This should be at the peak of the dry density curve.
2. Locate the dry density and moisture content on the family of curves proposed for use on the project to determine the curve to be used for the standard.

Select the curve nearest the point. If the point is between 2 curves and there is doubt as to which curve is closest, use the curve below the point.

The maximum dry density from this curve must be within ± 3 lbs./cu. ft. of the 4-point maximum dry density. If the curves fail to check within this tolerance, contact the Region Materials Engineer as the family of curves may not be reliable for this material.

3.4 Method 4 (Soils / Granular Material).

- A. Obtain a sample of approximately 15 lbs.
- B. Sieve the sample on a 3/4" sieve and discard any material retained.
- C. If the sample appears to be above optimum moisture, dry it sufficiently in an oven at a temperature not exceeding 140° F to bring it to approximately optimum.

If the sample appears dry, add and mix sufficient water to bring it near optimum.

- D. Mold and take a moisture sample, as shown in paragraphs 3.3 E. through 3.3 I. (Use the DOT-41 for density tests.)
- E. Using the "1-point determination" dry density and the "1-point" moisture determination, enter the family of curves Figure 9 to obtain the target maximum dry density and optimum moisture.

The family of curves must be the one identified by the 4-point determination. (See "NOTE" on page 1 of this procedure.)

Select the curve nearest the plotted point. If the plotted point is between 2 curves and there is doubt as to which curve is closest, use the curve below the plot.

NOTE: The peak of the curves presented in Figure 9 are not to be used as the target maximum dry density and optimum moisture. Use the table values corresponding for each curve letter for target values when conducting in-situ density testing. The maximum dry density provided by the table for the selected curve by the 1-point ("U" on the DOT- 41) shall not deviate from the maximum dry density determined by the 4-point curve established for the material by more than +/- 3 lbs./cu. Ft. The moisture content of the 1-point specimen will be no more than 1 percentage point above, or 2 percentage points below optimum moisture provided in the table for the curve selected. If either of these conditions exist, a second 1-point, closer to optimum will be made.

When changes in gradation occur which may affect density results, additional 4-point determinations shall be made, as directed by the Region Materials Engineer.

- 3.5 When Methods 2 and 4 are used in conjunction with SD 105 and SD 106, the material for testing is taken from or adjacent to the in-place density test hole and the DOT-41 form is used.

4. Report:

4.1 Calculations.

Calculate the moisture content and corresponding dry unit weight in lbs./ft³ as follows:

$$w = \frac{A - B \times 100}{B - C}$$

and

$$W = \frac{W_1 \times 100}{w + 100}$$

Where:

w = Percentage of moisture in specimen, based on dry weight of soil.

A = Weight of container and wet soil/granular material.

B = Weight of container and dry soil/granular material.

C = Weight of container.

W = Dry weight in lbs./ft³ of compacted material.

W₁ = Wet weight in lbs./ft³ of compacted material.

4.2 Report.

A. Report the following:

- (1) The optimum moisture content, as a percentage, to the nearest 0.1.
- (2) The maximum density in lbs./ft³ to the nearest 0.1 lb.
- (3) Test results will be reported on form DOT-40.

5. References:

AASHTO T 99
SD 101
SD 105
SD 106
SD 108
SD 201

DOT-40

9-14

File No. 16

SOUTH DAKOTA
DEPARTMENT OF
TRANSPORTATION

DENSITY SHEET

PROJECT IM 090-7(14)125 COUNTY Washington PCN _____
 OPERATOR Marv C. Cleason CHECKED BY RJH DATE _____
 _____ 8/8/96

Specimen Number	1	2	3	4	5	
Can Number	9	3	2	8	4	
Weight of Can and Wet Material	164.7	192.7	142.0	121.7	133.2	
Weight of Can and Dry Material	151.0	174.2	127.0	107.2	117.0	
Weight Loss (Moisture) Speedy Reading	13.7	18.5	15.0	14.5	16.2	
Weight of Can	14.0	16.0	17.5	13.9	15.8	
Weight of Dry Material	137.0	158.2	109.5	93.3	101.2	
Percent Moisture	10.0	11.7	13.7	15.5	16.0	

Weight of Mold and Wet Specimen	13.83	14.10	14.21	14.11	13.96	
Weight of Mold	9.71	9.71	9.71	9.71	9.71	
Weight of Wet Specimen	4.12	4.39	4.50	4.40	4.25	
Factor of Mold No. <u>2-90</u>	29.98	29.98	29.98	29.98	29.98	
Wet Density Wet Wt. x Factor	123.5	131.6	134.9	131.9	127.4	
Dry Density PCF	112.3	117.8	118.6	114.2	109.8	

PLOT WET AND DRY CURVES ON
REVERSE SIDE

Figure 1

DENSITY SHEET
File # 16

COUNTY Washington PROJECT I 96-7 (14) 513 PCN 7140
FIELD NO. 2 LAB NO. 278 DATE 8-8-96
SOURCE Borrow Pit #6 TYPE OF MATERIAL Clay
4-POINT DATA: OPTIMUM MOISTURE 13.1 MAXIMUM DENSITY 118.8
CURVE VALIDATION: FAMILY Ohio CURVE Small J MAX. DENSITY 118.1
GRANULAR MATERIAL 4-POINT RANGE _____ TO _____

(SEE REVERSE SIDE FOR CALCULATIONS)

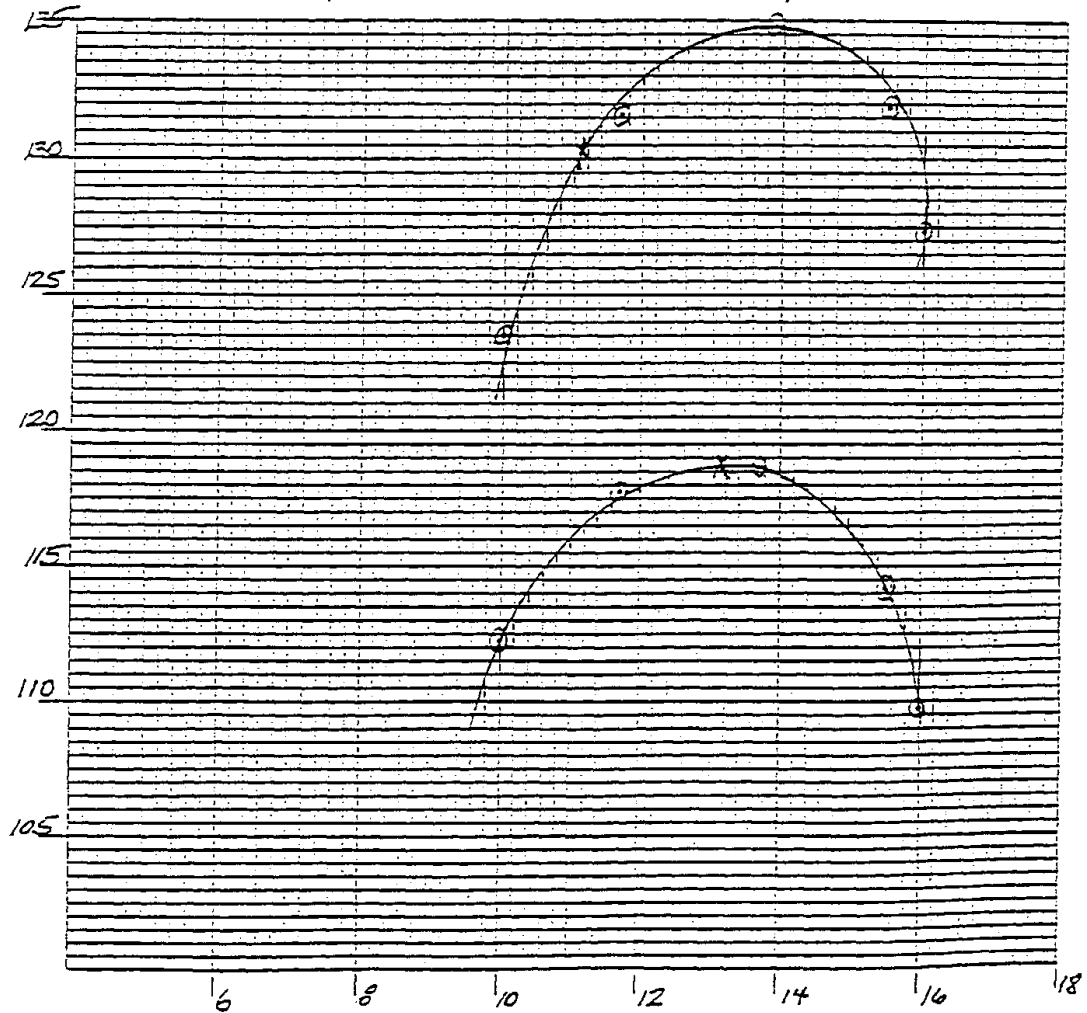

Figure 2

Sample ID 2204757
File No.

Density Sheet

DOT - 40
(09/2004)

County Aurora, Ziebach PCN/PROJECT B015 PH 0066(00)15
Field # 01 Tested By Tester, One Date Tested 04/22/2015 12:00 am
Checked By Tester, Two
Source Borrow #6 Material Type Unclassified Excavation
Comment

Specimen Number	1	2	3	4	5	6	7
Weight of Can and Wet Material	164.70	192.7	142.00	121.70	133.20		
Weight of Can and Dry Material	151.00	174.20	127.00	107.20	117.00		
Weight Loss (Moisture) Speedy Reading	13.7	18.5	15.0	14.5	16.2	0.0	0.0
Weight of Can	14.0	16.0	17.5	13.9	15.8		
Weight of Dry Material	137.0	158.2	109.5	93.3	101.2		
Percent Moisture	10.	11.7	13.7	15.5	16.		

Weight of Mold and Specimen	13.83	14.10	14.21	14.11	13.96		
Weight of Mold	9.71	9.71	9.71	9.71	9.71	9.71	9.71
Weight of Wet Specimen	4.120	4.390	4.500	4.400	4.250		
Factor of Mold No. 2.90	29.980	29.980	29.980	29.980	29.980	29.980	29.980
Wet Density $\frac{\text{Wet Wt.} \times \text{Factor}}{\text{Kg/m}^3 \text{ or PCF } 1000 \text{ for metric}}$	123.5	131.6	134.9	131.9	127.4		
Dry Density $\frac{\text{Kg/m}^3 \text{ or PCF}}$	112.3	117.8	118.6	114.2	109.8		

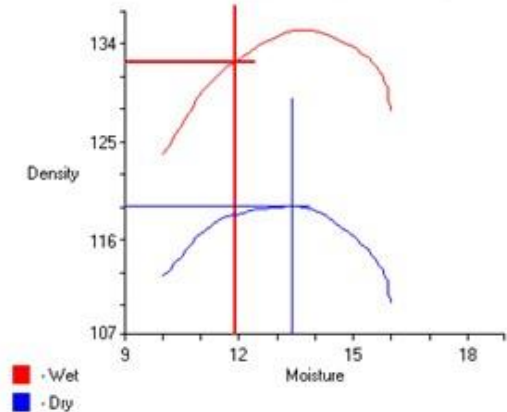

Wet Density:	132.0	Wet Moisture:	11.9
Dry Maximum Density:	118.7	Dry Optimum Moisture:	13.4
Four-Point Range:	115.7 - 121.7	Curve and Family:	J

Figure 3

OHIO HWY. DEPT TYPICAL MOISTURE DENSITY CURVES SET "C"
 INTERPOLATED CURVES ADDED BY SOUTH DAKOTA DEPT. OF HIGHWAYS SOILS LAB.

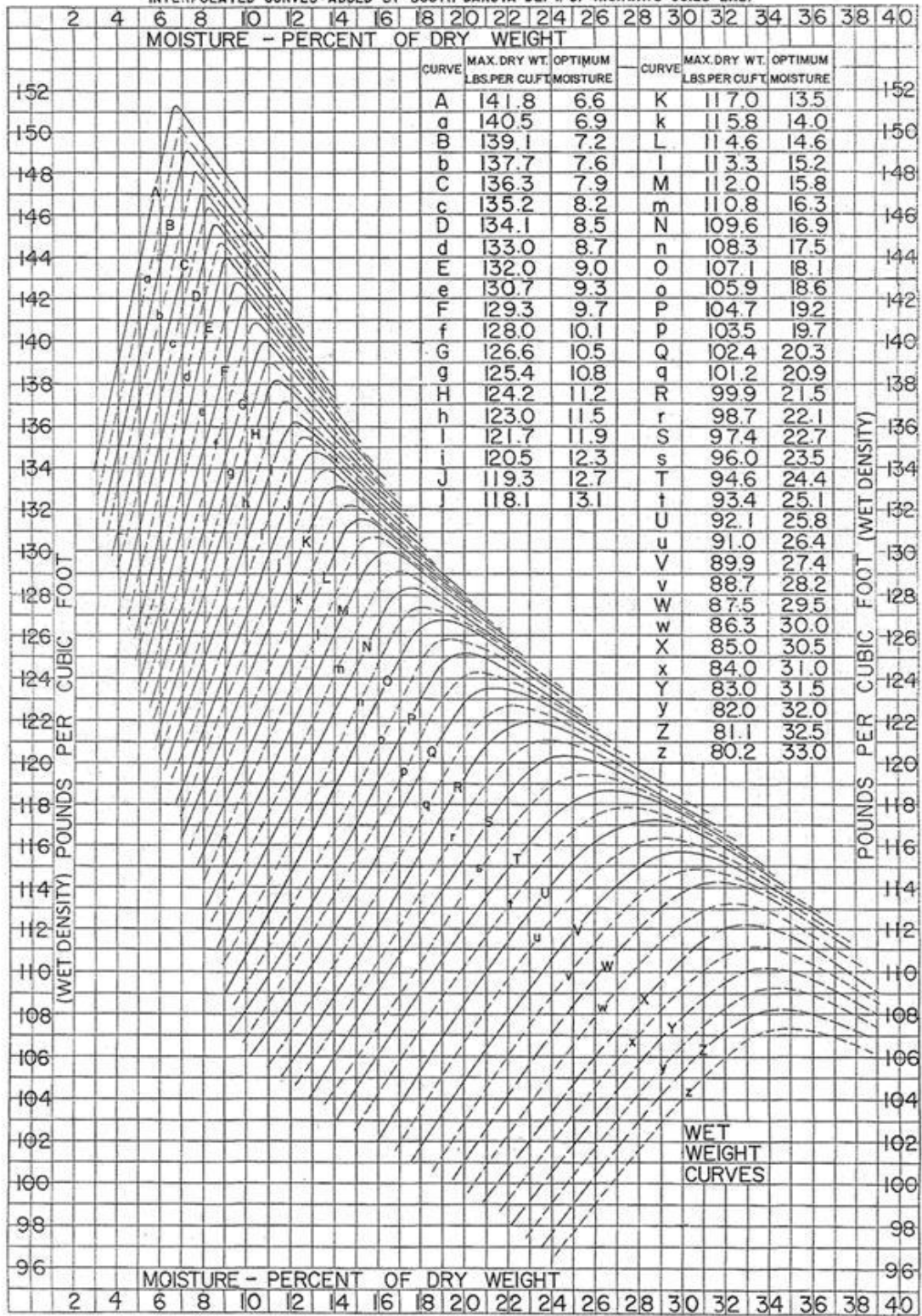

Figure 4

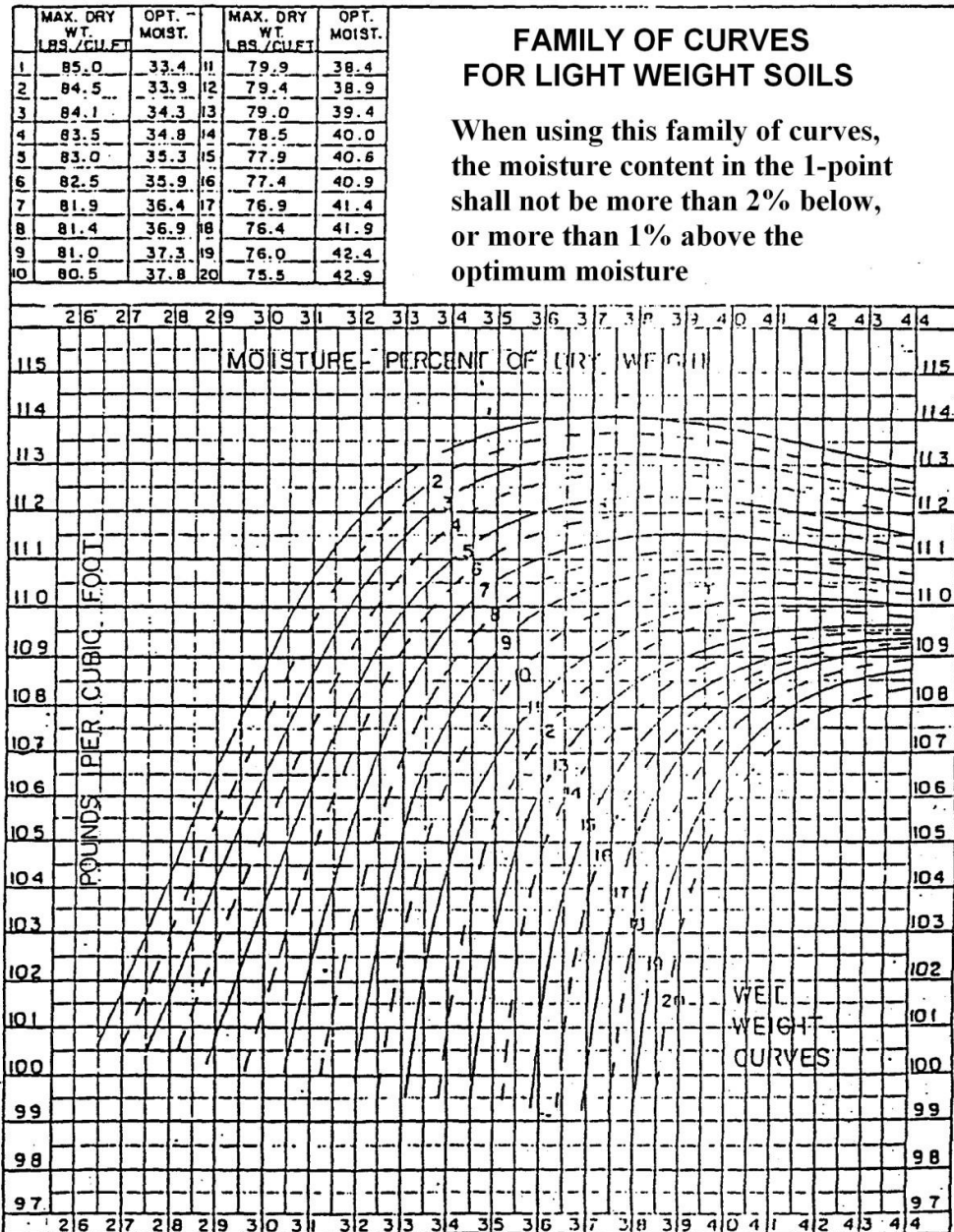

Figure 5

DOT-40
1-55

DENSITY SHEET
File # 17.2

COUNTY Washington PROJECT I 96-4 (14) 111 PCN 1423
FIELD NO. 6 LAB NO. H 92-46 DATE 8-8-96
SOURCE Plans Dit #2 TYPE OF MATERIAL Base Course
4-POINT DATA: OPTIMUM MOISTURE 8.6 MAXIMUM DENSITY 131.1
CURVE VALIDATION: FAMILY Ohio CURVE Little d MAX. DENSITY 133.0
GRANULAR MATERIAL 4-POINT RANGE 128.1 TO 134.1

(SEE REVERSE SIDE FOR CALCULATIONS)

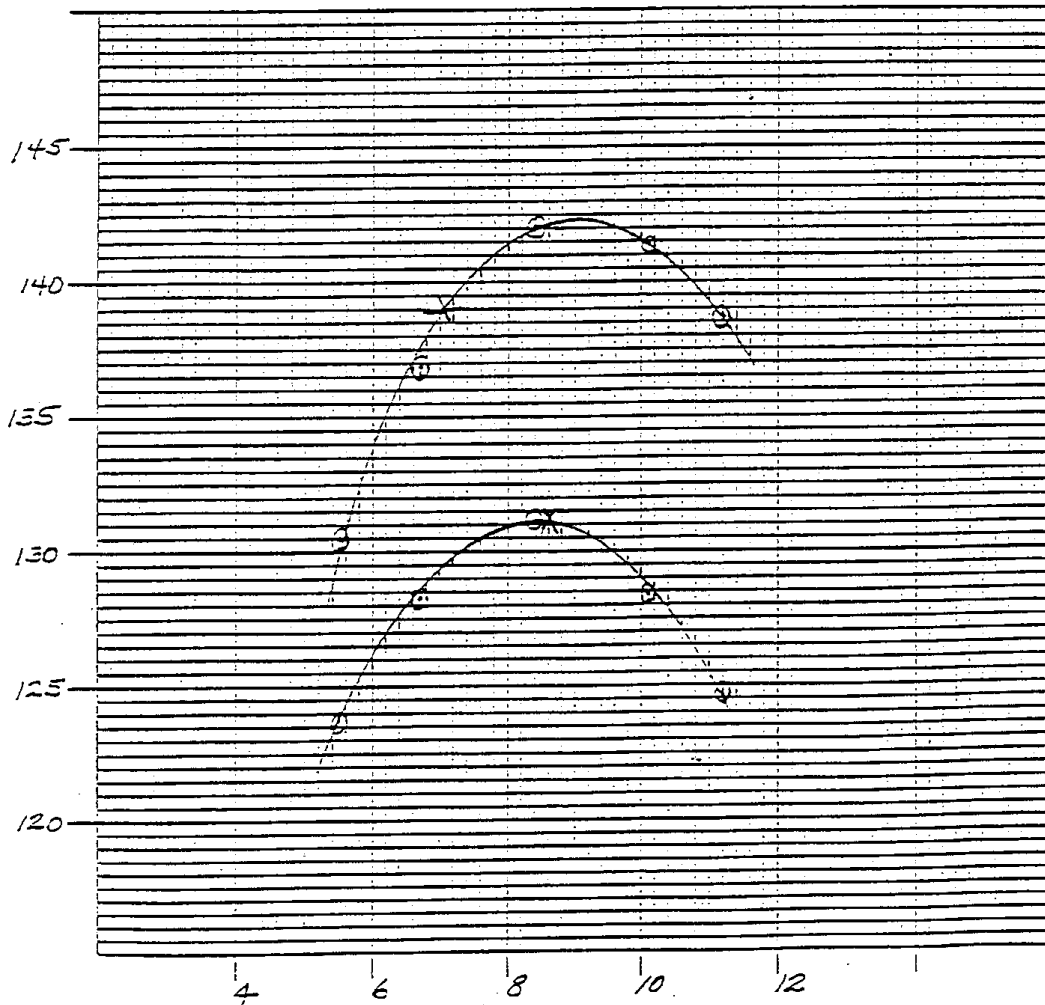

(Reverse side of DOT-40)

Figure 7

Sample ID 2204758
File No.

Density Sheet

DOT - 40
9-15

County Aurora, Ziebach PCN/PROJECT B015 PH 0066(00)15
Field # 01 Tested By Tester, One Date Tested 04/22/2015
Checked By Tester, Two
Source Jones Pit Material Type Base Course
Comment

Specimen Number	1	2	3	4	5	6	7
Weight of Can and Wet Material	631.4	654.9	651.3	625.0	669.1		
Weight of Can and Dry Material	602.5	619.0	607.2	574.9	610.0		
Weight Loss (Moisture) Speedy Reading	28.9	35.9	44.1	50.1	59.1	0.0	0.0
Weight of Can	76.3	83.7	81.9	79.1	81.4		
Weight of Dry Material	526.2	535.3	525.3	495.8	528.6		
Percent Moisture	5.5	6.7	8.4	10.1	11.2		

Weight of Mold and Specimen	22.58	23.06	23.45	23.40	23.19		
Weight of Mold	12.72	12.72	12.72	12.72	12.72	12.72	12.72
Weight of Wet Specimen	9.86	10.34	10.73	10.68	10.47		
Factor of Mold No. <u>2-67</u>	13.24	13.24	13.24	13.24	13.24	13.24	13.24
Wet Density <u>Wet Wt. x Factor</u>	130.5	136.9	142.1	141.4	138.6		
Dry Density	123.7	128.3	131.1	128.4	124.6		

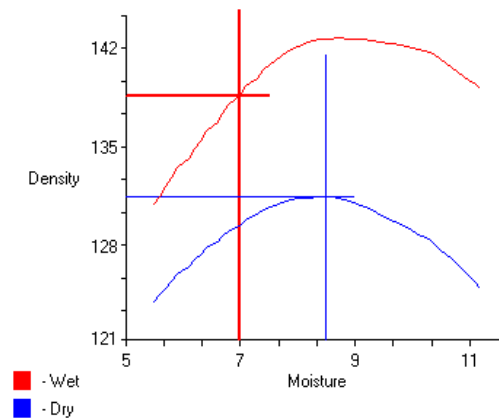

Wet Density: Wet Moisture:
 Dry Maximum Density: Dry Optimum Moisture:
 Four-Point Range: Curve and Family:

Figure 8

SDDOT Base and Subbase Moisture-Density Curves (Base Course and Subbase Granular Materials)

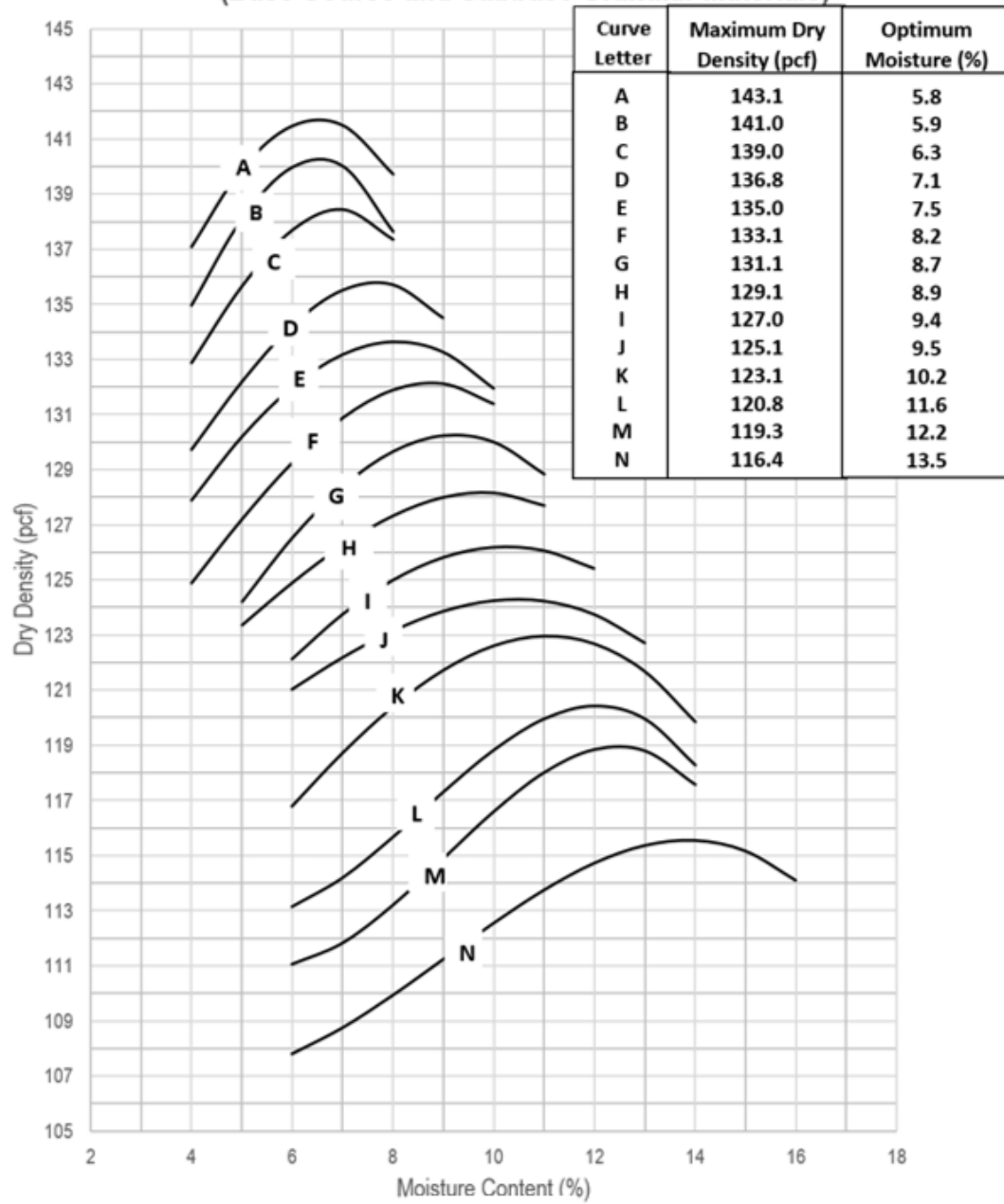

Figure 9

Appendix B: Data Analysis

Examples of each of the DOT data forms are provided in Figure 33 through Figure 36.

Sample ID 2203565 **Sieve Analysis and P.I. Worksheet** **DOT - 3 (Combined)**
File No. **9-14**

PROJECT PH 0066(00)15 **COUNTY** Aurora, Ziebach **PCN** B015

Charge to (If not above project)

Field No. 01 **Date Sampled** 03/10/2015 **12:00 am** **Date Tested** 03/10/2015 **12:00 am**

Sampled By Tester, One **Tested By** Tester, One **Checked By** Tester, Two

Material Type Base Course **Source** Richland Pit
Taken @ 180.5 tons **Lot No.** **Sublot No.**

Weight Ticket Number or Station Ticket #76427, Sta. 28+25 **Lift** 1 **of** 3

% moist. = (wet wt. - dry wt.) / dry wt. x 100 =

Original Dry Sample Wt. (0.1g) **7318.0**

Sieve Size	F.M.	Retained (.1g)	% total ret.(0.1%)	% pass. (0.1%)	% pass. (rounded)	Spec Req.
100	4					
75	3					
62.5	2 1/2					
50	2					
37.5	1 1/2					
31.5	1 1/4					
25	1	0.0	0.0	100.0	100	100-100
19	3/4	167.6	2.3	97.7	98	80-100
16	5/8	240.6	3.3	94.4	94	
12.5	1/2	351.7	4.8	89.6	90	68-91
9.5	3/8	338.8	4.6	85.0	85	
6.25	1/4	625.2	8.5	76.5	77	
4.75	#4	566.2	8.0	68.5	69	46-70
Pan		5006.1	68.4			
Total		7318.2				

+ #4 Gradation Check: within 0.3% of original dry wt. **0.0**

Sieve Size	retained (0.1g)	% total ret.(0.1%)	% total X % pa.#4(0.1%)	% pass. (0.1%)	% pass. (rounded)	Spec Req.
3.35	6					
2.36	8	136.5	21.6	14.8	53.7	54
2.00	10	28.2	4.5	3.1	50.6	51
1.70	12					
1.18	16	67.1	10.6	7.3	43.3	43
0.850	20	62.7	9.9	6.8	36.5	37
0.600	30	75.8	12.0	8.2	28.3	28
0.425	40	61.4	9.7	6.6	21.7	22
0.300	50	55.6	8.8	6.0	15.7	16
0.180	80	34.4	5.4	3.7	12.0	12
0.150	100	4.6	0.8	0.5	11.5	12
0.075	200	10.6	1.7	1.2	10.3	3.0-12.0
PAN dry		1.7	95.1	10.3		631.9
PAN wash		93.4	15.1			538.5
TOTAL		632.20		loss from washing (-#200)		93.4

Coarse x % Retain/Design =: **- #4 Gradation check:**
Chip x % Retain/Design =: within 0.3% of the
Fine x % Pass/Design =: wt. before washing **0.1**

Total/Combined - #200

Natural Sand	.00	Natural Fines	.00	Na. Rock	.00
Ma.Sand	.00	Filler	.00	Cr.Rock	.00
Cr.Fines	.00	Add Rock	.00		.00

Liquid Limit
a. can number **45** **P.L.** **19**
b. wt. can + wet soil (01g) **29.87** **28.34**
c. wt. can + dry soil (01g) **28.14** **27.11**
d. wt. of water (b - c) (01g) **1.73** **1.23**
e. wt. of can (01g) **19.92** **20.17**
f. wt. of dry soil (c - e) (01g) **8.22** **6.94**
g. Liquid Limit (d/f x j x 100) (0.1) **21.2** **N.P.**
h. Plastic Limit (d/f x 100) (0.1) **N.A.** **17.7**
i. P. I. (g - h) (0.1) **3.5**
Liquid Limit **N.C.** (g. rounded) **21** **N.A.**
Plasticity Index (i. rounded) **4**
j. corr. # blows **26** **22 = 0.9846, 23 = 0.9899, 24 = 0.9952**
25 = 1.0000, 26 = 1.0050, 27 = 1.0100, 28 = 1.0138
wt. - #40 **181.40** / wt. - #4 **611.20** x % pass.#4 = **20.3**
(± 3.0% VARIABLE of Acc. % pass. (0.1%) on the #40)

SPECIFICATION L.L. **0-25**
SPECIFICATION P.L. **0-6**

+ #4 % Particles less than 1.95 SP. GR.
Specific gravity of solution (1.95 ± 0.01) **.**
wt. of lightweight particles (0.1 g) **.**
weight of + #4 material (0.1 g) **.**
% lightweight particles **.**
SPECIFICATION **.**

- #4 % Particles less than 1.95 SP. GR.
Specific gravity of solution (1.95 ± 0.01) **.**
wt. of lightweight particles (0.1 g) **.**
weight of - #4 material (0.1 g) **.**
% lightweight particles **.**
SPECIFICATION **.**

Crushed Particles Test
weight of crushed particles **447.0**
weight of total + #4 sample **1015.9**
percent of crushed particles **44**
SPECIFICATION **1** or more FF. min. **30-100**

Figure 33: DOT-3 worksheet (Sieve Analysis).

Sample ID 2205425
File No.

Test Strip Worksheet

DOT - 28
9-14

PROJECT PH 0066(00)15 COUNTY Aurora, Ziebach PCN B015
 Test No. 02 Test Date 04/29/2016 Lift 2 of 3 Thickness 4"
 Tested By Tester, One Checked By Tester, Two
 Nuclear Gauge No. MQ 778 Test Mode 2" DIRECT TRANSMISSION

NUCLEAR GAUGE WET DENSITY lb/ft³

	STATION 32+50	STATION 33+50	STATION 34+50	STATION 35+50	AVERAGE
1st Reading Total Passes <u>4</u>	125.7	131.5	130.9	128.6	128.7
2nd Reading Total Passes <u>8</u>	128.5	133.8	133.1	130.2	131.4
3rd Reading Total Passes <u>12</u>	131.4	134.2	133.6	132.0	132.8
4th Reading Total Passes <u>16</u>	132.4	134.7	134.5	131.9	133.4
5th Reading Total Passes _____					
6th Reading Total Passes _____					
7th Reading Total Passes _____					

MOISTURE AND DRY DENSITY DETERMINATION

A. Final Wet Density	132.4	134.7	134.5	131.9
B. Weight of Can and Wet Material	2643.3	2476.9	2701.7	2519.8
C. Weight of Can and Dry Material	2524.4	2368.4	2584.1	2407.0
D. Weight of Moisture (B - C)	118.9	108.5	117.6	112.8
E. Weight of Can	452.4	344.3	574.8	311.9
F. Weight of Dry Material (C - E)	2072.0	2024.1	2009.3	2095.1
G. % Moisture (D x 100) / F	5.7	5.4	5.9	5.4
H. Dry Density (A x 100) / (100 + G)	125.3	127.8	127.0	125.1

Average Dry Density 126.3

Figure 34: DOT-28 worksheet (Test Strip).

Sample ID 2204758
File No.

Density Sheet

DOT - 40
9-15

County Aurora, Ziebach PCN/PROJECT B015 PH 0066(00)15
Field # 01 Tested By Tester, One Date Tested 04/22/2015
Checked By Tester, Two
Source Jones Pit Material Type Base Course
Comment

Specimen Number	1	2	3	4	5	6	7
Weight of Can and Wet Material	631.4	654.9	651.3	625.0	669.1		
Weight of Can and Dry Material	602.5	619.0	607.2	574.9	610.0		
Weight Loss (Moisture) Speedy Reading	28.9	35.9	44.1	50.1	59.1	0.0	0.0
Weight of Can	76.3	83.7	81.9	79.1	81.4		
Weight of Dry Material	526.2	535.3	525.3	495.8	528.6		
Percent Moisture	5.5	6.7	8.4	10.1	11.2		

Weight of Mold and Specimen	22.58	23.06	23.45	23.40	23.19		
Weight of Mold	12.72	12.72	12.72	12.72	12.72	12.72	12.72
Weight of Wet Specimen	9.86	10.34	10.73	10.68	10.47		
Factor of Mold No. 2.67	13.24	13.24	13.24	13.24	13.24	13.24	13.24
Wet Density $\frac{\text{Wet Wt.} \times \text{Factor}}$	130.5	136.9	142.1	141.4	138.6		
Dry Density	123.7	128.3	131.1	128.4	124.6		

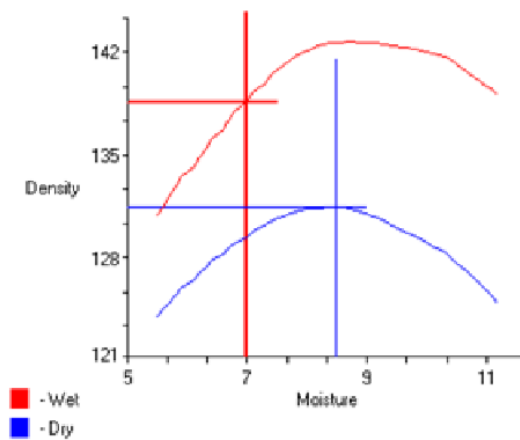

Wet Density: Wet Moisture:
 Dry Maximum Density: Dry Optimum Moisture:
 Four-Point Range: Curve and Family:

Figure 35: DOT-40 worksheet (Four-Point Laboratory Compaction Test)

Sample ID 2205560 **Density Report** DOT - 41
 File No. 9-16

County Aurora, Ziebach PCN/PROJECT B015 PH 0066(00)15

Station 47+15 Dist. From CL 13' L Width (Gravel) 52.00

Depth 4" (from top of Subgrade or Pipe) (Hole - Gravel) Field # 07

Tested By Tester (TEST), One Checked By Tester (TEST), Two Date 05/01/2015

 WORK AREA REPRESENTED (Circle what applies)

EMBANKMENT STA. TO STA. (per half mile, for each roadbed)
 Zone 1(0-1 ft.) Zone 2(1-3 ft.) Zone 3(3-5 ft.) Zone 4(5 ft. to base, 1 per 5 ft.)

BRIDGE END STA. TO STA.
 EMBANKMENT 1 per zone within plan limits 3 equal zones when backwall is less than 7 ft. 4 equal zones when backwall is 7 ft. or greater
 Zone 1 Zone 2 Zone 3 Zone 4

BERM STA. TO STA. (100 ft. from Bridge End)
 Zone 1(0-1 ft.) Zone 2(1-3 ft.) Zone 3(3-5 ft.) Zone 4(5 ft. to base, 1 per 5 ft.)

CROSS 24" or Smaller undercut (1/2 way up) (0-2 ft. Above)
 PIPE STORM 30" to 72" undercut (Lower 1/2) (Upper 1/2) (0-2 ft. Above)

INTERSECTION 72" or more undercut (Bottom 1/3) (Middle 1/3) (Top 1/3) (0-2 ft. Above)

After Minimum for size pipe installation 1 per 3 ft. of backfill beginning at 2' above top of pipe

SUBBASE STA. TO STA. LIFT

BASE COURSE STA. TO STA. 36+00 to 67+50 LIFT 2 of 3

Curve Used	Maximum Density	Optimum Moisture	Granular Material 4-Point Range	SPECIFICATION	95	%
	U. 126.3	%		% Obtained 100 X (G/U)	97	%

Balloon Method		Sand Density		Nuclear Method	
B. Wt. Undried Matl. from Hole	_____	A. Std. Sand PCF	_____	Meter No.	MQ 778
C. Volumeter Reading in Hole	_____	B. Wt. Undried Matl. from Hole	_____	Test Mode	2" DIRECT TRANSMISSION
D. Initial Volumeter Reading	_____	C. Initial Wt. Sand	_____	A. Wet Density from Gauge	128.70
E. Volume of Test Hole (C - D)	_____	D. Final Wt. Sand Plus Cone Sand	_____	± Corr. *	_____ = 128.7
F. Wet Density (B / E)	_____	E. Volume of Test Hole (C - D) / A	_____	B. Dry Density	122.0
G. Dry Density F / (100 + M) x 100	_____	F. Wet Density (B / E)	_____	A / (100 + M-Field) x 100	_____
		G. Dry Density F / (100 + M) x 100	_____		

1-Point Density Determination		Moisture Determinations		Rock Determination	
		1-Point	Field		
O. Weight of Mold & Specimen	_____	H. Wt. of Wet Matl. and Container	3120.4	A. Total Sample Weight	_____
P. Weight of Mold	_____	I. Wt. of Dry Matl. and Container	3009.9	B. Weight of Material Retained on 3/4" Sieve	_____
Q. Wet Wt. of Molded Specimen (O - P)	_____	J. Wt. of Moisture (H - I)	110.5	C. Percent Retained On 3/4" Sieve (B x 100)/A	_____
R. Factor of Mold No. Used in Test	_____	K. Wt. of Container	990.2		
S. Wet Density (Q x R)	_____	L. Wt. of Dry Matl. (I - K)	2019.7		
T. Dry Density S / (100 + M [1-PT]) x 100	_____	M. Percent Moisture Field (J x 100) / L	5.5		

* Correction from DOT-39. If there is no correction or, if the correction has been applied to the meter show "NA".

1-Point Not Made this Test, Refer to Test Strip Maximum Density: 126.30

Figure 36: DOT-41 worksheet (Field Density Test).

The data field definitions for each of the four DOT data forms are provided in Table 16 through Table 19.

Table 16: Data fields for DOT-3 worksheet (Sieve Analysis).

Data Field	Definition	Comment
Main PCN	Main Project Contract Number	Useful. Main PCN will be used to organize and link data from the various forms together.
Contract ID	Contract Identification Number	Useful. Contract ID will also be used to organize and link data from the various forms together.
Sample ID	Sample Identification Number	Useful. Used to track problematic or irregular samples within the data sets.
Sample Comment	Sample Comment	Useful. May provide additional information about samples.
Source_Desc	Description of source Location	Useful. May provide information about the sample variance observed among different regions.
Lift_Min	Lift tested	Ignored for DOT-40. Not particularly relevant to 4-Point testing.
Lift_Max	Total number of lifts to be tested.	Ignored for DOT-40. Not particularly relevant to 4-Point testing.
Lot_Nbr	Used for only asphalt concrete paving	Not used.
Sub_Lot_Nbr	Used for only asphalt concrete paving	Not used.
Station_Desc	Station location on project.	Not used.
Mat_Type_Name	Material type	Useful. Provides information that is key to grouping samples together.
Producer_Addr_Desc	Used on DOT-1 for material that was shipped to the project. Provides quarry location. Seldom used	Not used.
Requirement Type	Type of test run.	Useful.
Purpose	Reason for running test.	Useful.
DOT Form	The DOT form used for test (DOT-3).	Useful.
Test #	Test number	Useful.
Material Group	Material group of material tested.	Useful. Provides information that is key to grouping samples together.
Material	Type of material tested.	Useful. Provides information that is key to grouping samples together.
Item_Qty	Comes from CM&P. Quantity of the material to be used on the project. Tons or cubic yard.	Not used.
SBI_Nbr	Special Bid Item number	Not used.
SBI_Desc	Special Bid Item Description	Not used.
Test_DateTime	Date and Time of test.	Useful. May provide insight into sample variance.
Prepared_Ind	Check box used to show if the test is prepared (final) or draft. I would not use any unprepared tests.	Useful.
Test Form Comment	Comments on test form.	Useful. May provide additional information about samples.
File_Nbr	File Number.	Not used.

Data Field	Definition	Comment
IA_Observed_Ind	Check box used when the Independent Assurance test is done by observation. No actual testing done. Ignore these tests.	Useful.
Specification Group	Type of specifications used for test.	Useful.
Tolerance Group	Tolerance used between the acceptance and independent assurance test. Ignore	Not used.
Test -->	Course sieves analysis.	Useful.
Measure_Unit	Measurement unit. In this case grams, g.	Useful.
Sample_Wgt	Sample weight retained.	Useful.
4 in. sieve	Sample weight retained.	Ignored. Not required for Base Course or Salvage.
3 in. sieve	Sample weight retained.	Ignored. Not required for Base Course or Salvage.
2 1/2 in. sieve	Sample weight retained.	Ignored. Not required for Base Course or Salvage. Recycled PCC has 100% passing the 2 1/2" sieve.
2 in. sieve	Sample weight retained.	Ignored. Not required for Base Course or Salvage. Subbase has 100% passing the 2" sieve.
1 1/2 in. sieve	Sample weight retained.	Ignored. Not required for Base Course or Salvage. Salvage has a 100% passing the 1 1/2" sieve.
1 1/4 in. sieve	Sample weight retained.	Useful.
1 in. sieve	Sample weight retained.	Useful.
3/4 in. sieve	Sample weight retained.	Useful.
5/8 in. sieve	Sample weight retained.	Useful.
1/2 in. sieve	Sample weight retained.	Useful.
3/8 in. sieve	Sample weight retained.	Useful.
1/4 in. sieve	Sample weight retained.	Useful.
#4 sieve	Sample weight retained.	Useful.
Upper Pan	Sample weight retained.	Useful.
Sample_Before_Wash_Wgt	Sample weight before wash.	Useful.
Sample_After_Wash_Wgt	Sample weight after wash.	Useful.
Wet_Sample_Wgt	Wet sample weight.	Useful.
Combined_Minus_200_Ind	Used for determining the combined - #200. Not used for base course or salvage. Mainly for AC, PCC & chip seals	Not used.
Upper Sieves Waivered	Waiver of upper sieves.	Useful. Base course should not have sieves waived. A waiver means that the percent passing is not compared to the specs.
Test -->	Fine sieves.	Useful.
Sample_Before_Wash_Wgt	Sample weight before wash.	Useful.
Sample_After_Wash_Wgt	Sample weight after wash.	Useful.
#6 sieve	Sample weight retained.	Useful.
#8 sieve	Sample weight retained.	Useful.
#10 sieve	Sample weight retained.	Useful.

Data Field	Definition	Comment
#12 sieve	Sample weight retained.	Useful.
#16 sieve	Sample weight retained.	Useful.
#20 sieve	Sample weight retained.	Useful.
#30 sieve	Sample weight retained.	Useful.
#40 sieve	Sample weight retained.	Useful.
#50 sieve	Sample weight retained.	Useful.
#80 sieve	Sample weight retained.	Useful.
#100 sieve	Sample weight retained.	Useful.
#200 sieve	Sample weight retained.	Useful.
Lower Pan	Sample weight retained.	Useful.
3/8 in. sieve	Sample weight retained.	Useful.
1/4 in. sieve	Sample weight retained.	Useful.
#4 sieve	Sample weight retained.	Useful.
Combined_Minus_200_Ind	Used for determining the combined - #200. Not used for base course or salvage. Mainly for AC, PCC & chip seals	Not used.
Lower Sieves Waivered	Waiver of upper sieves.	Useful. Base course should not have sieves waived. A waiver means that the percent passing is not compared to the specs.
Test -->	Liquid Limit Test	Useful. Key to analyzing moisture sensitivity.
Liquid_Limit_Blow_Qty	Number of test blows required.	Useful. Key to analyzing moisture sensitivity.
Can_Nbr	Can Number.	Useful. Key to analyzing moisture sensitivity.
Can_Plus_Wet_Soil_Wgt	Can weight plus wet soil weight.	Useful. Key to analyzing moisture sensitivity.
Can_Plus_Dry_Soil_Wgt	Can weight plus dry soil weight.	Useful. Key to analyzing moisture sensitivity.
Sample_Minus_4_Wgt	Used to determine if there is enough - #40 material. SD 207. Ignore	Not used.
Sample_Minus_40_Wgt	Used to determine if there is enough - #40 material. SD 207. Ignore	Not used.
Can_Wgt	Weight of can.	Useful. Key to analyzing moisture sensitivity.
Non_Controllable_Ind	Check box used if the material is uncontrollable in the LL machine. SD 207	Not used.
Skip_Acceptability_Ind	Used for soils only. Ignore	Not used.
Liquid Limit Waivered	Waiver Liquid Limit Test.	Useful. Key to analyzing moisture sensitivity.
Test -->	Plastic Limit Test	Useful. Key to analyzing moisture sensitivity.
Can_Nbr	Can Number.	Useful. Key to analyzing moisture sensitivity.
Can_Plus_Wet_Soil_Wgt	Can weight plus wet soil	Useful. Key to analyzing moisture sensitivity.
Can_Plus_Dry_Soil_Wgt	Can weight plus dry soil	Useful. Key to analyzing moisture sensitivity.

Data Field	Definition	Comment
Can_Wgt	Can weight.	Useful. Key to analyzing moisture sensitivity.
Non_Plastic_Ind	Check box used if the material cannot be rolled. Non-plastic. SD 207	Not used.
Plastic Limit Waivered	Waiver of Plastic Limit.	Useful. Key to analyzing moisture sensitivity.
Test -->	Crushed Particles Test.	Useful.
Sample_Wgt	Sample weight	Useful.
Crushed_Pieces_Wgt	Weight of crushed pieces.	Useful.
Fractured_Faces_Nbr	Number of fractured faces.	Useful.
Crushed Particles Waivered	Waiver of Crushed Particles test.	Useful.
Test -->	Light weight particles test. + #4	Not used.
Plus_4_Sample_Wgt	Weight of sample.	Not used.
Plus_4_Lt_Particles_Wgt	Weight of the floating Lt. Wgt. Particles	Not used.
Plus_4_Specific_Gravity	Specific Gravity.	Not used.
Light Weight Particles +#4 Waivered	Waiver of light weight particles test.	Not used.
Test -->	Light weight particles test. - #4	Not used.
Minus_4_Sample_Wgt	Weight of sample.	Not used.
Minus_4_Lt_Particles_Wgt	Weight of the floating Lt. Wgt. Particles	Not used.
Minus_4_Specific_Gravity	Specific Gravity.	Not used.
Light Weight Particles -#4 Waivered	Waiver of light weight particles test.	Not used.
Test -->	Not an actual test. The values are the % passing the +4 sieves and what is retained on the - #4 sieves. There is nothing shown for base course.	Not used.
Fine_Aggregate_Pct	Percent Fine aggregate in sample.	Useful.
Coarse_Aggregate_Pct	Percent coarse aggregate in sample.	Useful.
Combined Minus 200 Waivered	Waiver of minus 200	Useful.

Table 17: Data fields for DOT-28 worksheet (Test Strip).

Data Field	Definition	Comments
Main PCN	Main Project Contract Number	Useful. Main PCN will be used to organize and link data from the various forms together.
Contract ID	Contract Identification Number	Useful. Contract ID will also be used to organize and link data from the various forms together.
Sample ID	Sample Identification Number	Useful. Used to track problematic or irregular samples within the data sets.
Sample Comment	Sample Comment	Useful. May provide additional information about samples.
Source_Desc	Description of source Location	Useful. May provide information about the sample variance observed among different regions.
Lift_Min	Lift tested	Not used for DOT-40. Not particularly relevant to 4-Point testing.
Lift_Max	Total number of lifts to be tested.	Not used for DOT-40. Not particularly relevant to 4-Point testing.
Lot_Nbr	Used for only asphalt concrete paving	Not used.
Sub_Lot_Nbr	Used for only asphalt concrete paving	Not used.
Station_Desc	Station location on project.	Not used.
Mat_Type_Name	Material type	Useful. Provides information that is key to grouping samples together.
Producer_Addr_Desc	Used on DOT-1 for material that was shipped to the project. Provides quarry location. Seldom used	Not used.
Requirement Type	Type of test run.	Useful.
Purpose	Reason for running test.	Useful.
DOT Form	The DOT form used for test (DOT-28).	Useful.
Test #	Test number	Useful.
Material Group	Material group of material tested.	Useful. Provides information that is key to grouping samples together.
Material	Type of material tested.	Useful. Provides information that is key to grouping samples together.
Item_Qty	Comes from CM&P. Quantity of the material to be used on the project. (Tons or cubic yards)	Not used.
SBI_Nbr	Special Bid Item number	Not used.
SBI_Desc	Special Bid Item Description	Not used.
Test_DateTime	Date and Time of test.	Useful. May provide insight into sample variance.
Prepared_Ind	Check box used to show if the test is prepared (final) or draft. I would not use any unprepared tests.	Useful.
Test Form Comment	Comments on test form.	Useful. May provide additional information about samples.
File_Nbr	File Number.	Not used.
IA_Observed_Ind	No Independent Assurance. Will always be N. Ignore.	Not used.
Specification Group	There is not one for test strips	Not used.

Data Field	Definition	Comments
Tolerance Group	No actual tolerances for DOT-28. Ignore	Not used.
Gauge Desc	Type of Nuclear Density Gauge used.	Useful. All gauges will be Troxler 3430 or 3440.
Nuclear Test Type	Type of Nuclear Density test conducted and depth of transmission.	Useful.
Std_Cnt	Standard Count recorded by Nuclear Density Gauge prior to testing.	Useful. This has no value. Ignore
Passes_Nbr_1	Number of roller passes at reading 1	Useful.
Passes_Nbr_2	Number of roller passes at reading 2	Useful.
Passes_Nbr_3	Number of roller passes at reading 3	Useful.
Passes_Nbr_4	Number of roller passes at reading 4	Useful.
Passes_Nbr_5	Number of roller passes at reading 5	Useful.
Passes_Nbr_6	Number of roller passes at reading 6	Useful.
Passes_Nbr_7	Number of roller passes at reading 7	Useful.
Seq_Nbr	This signals that the following data can be found under the first column on the SD 219. The following data would be that of the first test station in the test strip.	Useful.
Density_Pct_1	Wet Density reading 1 at station 1	Useful.
Density_Pct_2	Wet Density reading 2 at station 1	Useful.
Density_Pct_3	Wet Density reading 3 at station 1	Useful.
Density_Pct_4	Wet Density reading 4 at station 1	Useful.
Density_Pct_5	Wet Density reading 5 at station 1	Useful.
Density_Pct_6	Wet Density reading 6 at station 1	Useful.
Density_Pct_7	Wet Density reading 7 at station 1	Useful.
Wet_Mat_Plus_Container_Wgt	Wet material and container weight of first test station.	Useful.
Dry_Mat_Plus_Container_Wgt	Dry material and container weight of first test station.	Useful.
Container_Wgt	Container weight of first test station.	Useful.
Seq_Nbr	This signals that the following data can be found under the second column on the SD 219. The following data would be that of the second test station in the test strip.	Useful.
Density_Pct_1	Wet Density reading 1 at station 2	Useful.
Density_Pct_2	Wet Density reading 2 at station 2	Useful.
Density_Pct_3	Wet Density reading 3 at station 2	Useful.
Density_Pct_4	Wet Density reading 4 at station 2	Useful.
Density_Pct_5	Wet Density reading 5 at station 2	Useful.
Density_Pct_6	Wet Density reading 6 at station 2	Useful.
Density_Pct_7	Wet Density reading 7 at station 2	Useful.

Data Field	Definition	Comments
Wet_Mat_Plus_Container_Wgt	Wet material and container weight of second test station.	Useful.
Dry_Mat_Plus_Container_Wgt	Dry material and container weight of second test station.	Useful.
Container_Wgt	Container weight of second test station.	Useful.
Seq_Nbr	This signals that the following data can be found under the third column on the SD 219. The following data would be that of the third test station in the test strip.	Useful.
Density_Pct_1	Wet Density reading 1 at station 3	Useful.
Density_Pct_2	Wet Density reading 2 at station 3	Useful.
Density_Pct_3	Wet Density reading 3 at station 3	Useful.
Density_Pct_4	Wet Density reading 4 at station 3	Useful.
Density_Pct_5	Wet Density reading 5 at station 3	Useful.
Density_Pct_6	Wet Density reading 6 at station 3	Useful.
Density_Pct_7	Wet Density reading 7 at station 3	Useful.
Wet_Mat_Plus_Container_Wgt	Wet material and container weight of third test station.	Useful.
Dry_Mat_Plus_Container_Wgt	Dry material and container weight of third test station.	Useful.
Container_Wgt	Container weight of third test station.	Useful.
Seq_Nbr	This signals that the following data can be found under the fourth column on the SD 219. The following data would be that of the fourth test station in the test strip.	Useful.
Density_Pct_1	Wet Density reading 1 at station 1	Useful.
Density_Pct_2	Wet Density reading 2 at station 1	Useful.
Density_Pct_3	Wet Density reading 3 at station 1	Useful.
Density_Pct_4	Wet Density reading 4 at station 1	Useful.
Density_Pct_5	Wet Density reading 5 at station 1	Useful.
Density_Pct_6	Wet Density reading 6 at station 1	Useful.
Density_Pct_7	Wet Density reading 7 at station 1	Useful.
Wet_Mat_Plus_Container_Wgt	Wet material and container weight of fourth test station.	Useful.
Dry_Mat_Plus_Container_Wgt	Dry material and container weight of fourth test station.	Useful.
Container_Wgt	Container weight of fourth test station.	Useful.

Table 18: The data fields for DOT-40 worksheet (Four-Point Laboratory Compaction Test).

Data Fields	Definition	Comments
Main PCN	Main Project Contract Number	Useful. Main PCN will be used to organize and link data from the various forms together.
Contract ID	Contract Identification Number	Useful. Contract ID will also be used to organize and link data from the various forms together.
Sample ID	Sample Identification Number	Useful. Used to track problematic or irregular samples within the data sets.
Sample Comment	Sample Comment	Useful. May provide additional information about samples.
Source_Desc	Description of source Location	Useful. May provide information about the sample variance observed among different regions.
Lift_Min	Lift tested	Not used for DOT-40. Not particularly relevant to 4-Point testing.
Lift_Max	Total number of lifts to be tested.	Ignored for DOT-40. Not particularly relevant to 4-Point testing.
Lot_Nbr	Used for only asphalt concrete paving	Not used.
Sub_Lot_Nbr	Used for only asphalt concrete paving	Not used.
Station_Desc	Station location on project.	Useful.
Mat_Type_Name	Material type	Useful. Provides information that is key to grouping samples together.
Producer_Addr_Desc	Used on DOT-1 for material that was shipped to the project. Provides quarry location. Seldom used	Not used.
Requirement Type	Type of test run.	Useful.
Purpose	Reason for running test.	Useful.
DOT Form	The DOT form used for test (DOT-40).	Useful.
Test #	Test number	Useful.
Material Group	Material group of material tested.	Useful. Provides information that is key to grouping samples together.
Material	Type of material tested.	Useful. Provides information that is key to grouping samples together.
Item_Qty	Comes from CM&P. Quantity of the material to be used on the project. (Tons or cubic yards)	Not used.
SBI_Nbr	Special Bid Item number	Not used.
SBI_Desc	Special Bid Item Description	Not used.
Test_DateTime	Date and Time of test.	Useful. May provide insight into sample variance.
Prepared_Ind	Check box used to show if the test is prepared (final) or draft. I would not use any unprepared tests.	Useful.
Test Form Comment	Comments on test form.	Useful. May provide additional information about samples.

Data Fields	Definition	Comments
File_Nbr	File Number.	Not used.
IA_Observed_Ind	No Independent Assurance. Will always be N. Ignore.	Not used.
Specification Group	Type of specifications used for test.	Useful.
Tolerance Group	No actual tolerances for DOT-40. Ignore	Not used.
Density Curve Letter	Density curve letter designation for material tested.	Useful. Will be key in analyzing the effectiveness of the Ohio Curves.
Density Curve Family	Density curve family designation for material tested.	Useful. Will be key in analyzing the effectiveness of the Ohio Curves.
Seq_Nbr	This defines which specimen number the following data belongs to. (defines the data column on the DOT-40)	Useful.
Mold_Nbr	Mold number used for test.	Useful.
Mold_Wgt	Weight of the mold used for the test.	Useful.
Mold_Factor	Mold factor number used for the test.	Useful.
Mold_Plus_Wet_Mat_Wgt	Weight of the mold and wet material.	Useful.
Wet_Mat_Plus_Container_Wgt	Weight of wet material and container.	Useful.
Dry_Mat_Plus_Container_Wgt	Weight of dry material and container.	Useful.
Container_Wgt	Container weight.	Useful.

Table 19: The data fields for DOT-41 worksheets (Field Density Test).

Data Fields	Definition	Comments
Main PCN	Main Project Contract Number	Useful. Main PCN will be used to organize and link data from the various forms together.
Contract ID	Contract Identification Number	Useful. Contract ID will also be used to organize and link data from the various forms together.
Sample ID	Sample Identification Number	Useful. Used to track problematic or irregular samples within the data sets.
Sample Comment	Sample Comment	Useful. May provide additional information about samples.
Source_Desc	Description of source Location	Useful. May provide information about the sample variance observed among different regions.
Lift_Min	Lift tested	Not used for DOT-40. Not particularly relevant to 4-Point testing.
Lift_Max	Total number of lifts to be tested.	Not used for DOT-40. Not particularly relevant to 4-Point testing.
Lot_Nbr	Used for only asphalt concrete paving	Not used.
Sub_Lot_Nbr	Used for only asphalt concrete paving	Not used.
Station_Desc	Station location on project.	Not used.
Mat_Type_Name	Material type	Useful. Provides information that is key to grouping samples together.
Producer_Addr_Desc	Used on DOT-1 for material that was shipped to the project. Provides quarry location. Seldom used	Not used.
Requirement Type	Type of test run.	Useful.
Purpose	Reason for running test.	Useful.
DOT Form	The DOT form used for test (DOT-40).	Useful.
Test #	Test number	Useful.
Material Group	Material group of material tested.	Useful. Provides information that is key to grouping samples together.
Material	Type of material tested.	Useful. Provides information that is key to grouping samples together.
Item_Qty	Comes from CM&P. Quantity of the material to be used on the project. Tons or cubic yards.	Not used.
SBI_Nbr	Special Bid Item number	Not used.
SBI_Desc	Special Bid Item Description	Not used.
Test_DateTime	Date and Time of test.	Useful. May provide insight into sample variance.
Prepared_Ind	Check box used to show if the test is prepared (final) or draft. I would not use any unprepared tests.	Useful.

Data Fields	Definition	Comments
Test Form Comment	Comments on test form.	Useful. May provide additional information about samples.
File_Nbr	File Number.	Not used.
IA_Observed_Ind	No Independent Assurance. Will always be N. Ignore.	Not used.
Specification Group	Type of specifications used for test.	Useful.
Tolerance Group	No tolerances. Ignore	Not used.
Wet_Mat_Wgt	Weight of wet material.	Useful.
Initial_Volumeter	Initial volumeter reading.	Useful.
Hole_Volumeter	Volumeter reading in hole.	Useful.
Balloon Method Waivered	Waiver of Balloon Method.	Useful.
Std_Sand_Density	Density of test sand used for the test.	Useful.
Wet_Mat_Wgt	Weight of wet material from test hole.	Useful.
Initial_Sand_Wgt	Initial weight of sand in sand cone and sand cone apparatus.	Useful.
Final_Sand_Wgt	Final weight of sand in sand cone and sand cone apparatus.	Useful.
Cone_Sand_Wgt	Weight of sand cone apparatus	Useful.
Sand Method Waivered	Waiver of sand cone method.	Useful.
Wet_Density_Correction_Factor	Wet Density Correction factor used for test.	Useful.
Moisture_Pct_Correction_Factor	Percent moisture correction factor used for test.	Useful. You probably will not see any correction factors after 06
Std_Cnt	Standard count recorded prior to testing.	Not used.
Std_Moisture_Cnt	Moisture standard count recorded prior to testing.	Not used.
Nuclear Test Type	Type of Nuclear Density test conducted and depth of transmission.	Useful.
Nuclear Gauge	Type of Nuclear Density Gauge used.	Useful. All gauges will be Troxler 3430 or 3440.
Corrected_Moisture	Quit using Nuclear moisture for the in place density in 06.	Useful.
Waiver_Ind	I think that this was used to waive the nuclear moisture. Before 06?	Useful.
Wet_Density_Amt	Wet Density recorded from Gauge.	Useful.
Moisture_Pct	Percent moisture recorded from Gauge. (not used)	Useful.
Dry_Density_Amt	Dry Density recorded from Gauge. (not used)	Useful.
Dry_Density_From_Gauge_Ind	Dry Density from Gauge used. (no)	Useful.

Data Fields	Definition	Comments
Density_Waiver_Ind	Waiver of Nuclear Method.	Useful.
Density Curve Letter	Density curve letter designation for material tested.	Useful. Will be key in analyzing the effectiveness of the Ohio Curves.
Density Curve Family	Density curve family designation for material tested.	Useful. Will be key in analyzing the effectiveness of the Ohio Curves.
Mold_Nbr	Mold number used for test.	Useful. Will be key in analyzing the effectiveness of the Ohio Curves.
Mold_Wgt	Weight of Mold used for test.	Useful. Will be key in analyzing the effectiveness of the Ohio Curves.
Mold_Factor	Mold factor used for test.	Useful. Will be key in analyzing the effectiveness of the Ohio Curves.
Mold_Plus_Wet_Mat_Wgt	Weight of mold and wet material used for test.	Useful. Will be key in analyzing the effectiveness of the Ohio Curves.
Wet_Mat_Plus_Container_Wgt	Weight of wet material and container.	Useful. Will be key in analyzing the effectiveness of the Ohio Curves.
Dry_Mat_Plus_Container_Wgt	Weight of dry material and container.	Useful. Will be key in analyzing the effectiveness of the Ohio Curves.
Container_Wgt	Weight of container	Useful. Will be key in analyzing the effectiveness of the Ohio Curves.
Test_Strip_Val	This is the dry density from the test strip DOT-28	Useful.
Wet_Mat_Plus_Container_Wgt	Weight of wet material and container.	Useful.
Dry_Mat_Plus_Container_Wgt	Weight of dry material and container.	Useful.
Container_Wgt	Weight of container	Useful.
Field Moisture Waivered	Waiver of field moisture.	Useful.
Sample_Wgt	Weight of total sample.	Useful.
Nbr4_Sieve_Wgt	Weigh of sample retained on the #4 sieve.	Useful.
Rock Determination Waivered	Waiver of rock determination.	Useful.

The data selected to be used in the analysis presented in Chapter 3 was collected from DOT-40 worksheets. The data points are presented in Table 20 through Table 33.

Table 20: DOT-40 points used for compaction curves with a maximum dry unit weight below 118 pcf.

Main PCN	Contract ID	Sample ID	Test #	Seq_Nbr	Wet Density (pcf)	Dry Density (pcf)	Moisture Content (%)
6394	2144	1441023	IA01	1	119.3	108.6	9.8
6394	2144	1441023	IA01	2	127.9	113.3	12.9
6394	2144	1441023	IA01	3	132.2	115.2	14.7
6394	2144	1441023	IA01	4	130.8	111.0	17.9
6250	4529	2191541	01	1	115.1	108.7	6.0
6250	4529	2191541	01	2	118.3	109.7	7.8
6250	4529	2191541	01	3	124.8	113.5	10.0
6250	4529	2191541	01	4	130.7	117.3	11.4
6250	4529	2191541	01	5	131.6	115.3	14.1
03W1	4835	2209280	01	1	116.6	108.5	7.4
03W1	4835	2209280	01	2	121.7	111.4	9.3
03W1	4835	2209280	01	3	127.6	115.1	10.9
03W1	4835	2209280	01	4	130.8	115.9	12.9
03W1	4835	2209280	01	5	130.8	114.2	14.5

Table 21: DOT- 40 points used for compaction curves with a maximum dry unit weight between 118 pcf to 120 pcf.

Main PCN	Contract ID	Sample ID	Test #	Seq_Nbr	Wet Density (pcf)	Dry Density (pcf)	Moisture Content (%)
1230	1511	1127153	07	1	132.8	118.2	12.4
1230	1511	1127153	01	2	119.9	110.6	8.5
1230	1511	1127153	07	3	124.7	113.7	9.7
1230	1511	1127153	01	4	131.5	118.5	10.9
6180	2104	1467173	01	1	116.6	111.1	5.0
6180	2104	1467173	01	2	124.3	115.7	7.4
6180	2104	1467173	01	3	128.9	117.7	9.4
6180	2104	1467173	01	4	133.4	119.5	11.6
00QD	2177	1416832	IA01	1	119.8	108.9	10.1
00QD	2177	1416832	IA01	2	134.5	118.6	13.5
00QD	2177	1416832	IA01	4	134.0	117.7	13.9
00QD	2177	1416832	IA01	5	133.0	116.3	14.3

Main PCN	Contract ID	Sample ID	Test #	Seq_Nbr	Wet Density (pcf)	Dry Density (pcf)	Moisture Content (%)
01QT	3332	2154783	01	1	124.7	114.3	9.1
01QT	3332	2154783	01	2	131.4	117.5	11.9
01QT	3332	2154783	01	3	132.5	117.9	12.3
01QT	3332	2154783	01	4	130.5	112.8	15.6
6662	3499	2108075	01	1	118.5	110.6	7.1
6662	3499	2108075	01	2	125.1	114.2	9.6
6662	3499	2108075	01	3	131.4	118.8	10.6
6662	3499	2108075	01	4	133.0	117.4	13.3
6662	3499	2108075	01	5	132.1	114.9	15.0
6662	3499	2115708	02	1	116.7	111.8	4.4
6662	3499	2115708	02	2	121.7	113.9	6.8
6662	3499	2115708	02	3	127.5	117.1	8.9
6662	3499	2115708	02	4	131.5	119.2	10.4
6662	3499	2115708	02	5	134.6	119.0	13.1
0254	3772	2135210	02	1	115.5	109.8	5.2
0254	3772	2135210	02	2	122.4	114.0	7.3
0254	3772	2135210	02	3	129.3	118.0	9.6
0254	3772	2135210	02	4	133.5	119.5	11.7
0254	3772	2135210	02	5	133.5	117.8	13.3
037K	4539	2190975	03	1	118.6	110.4	7.4
037K	4539	2190975	03	2	124.3	114.1	9.0
037K	4539	2190975	03	3	130.9	118.3	10.7
037K	4539	2190975	03	4	134.0	119.3	12.3
037K	4539	2190975	03	5	133.2	117.2	13.7
027U	4553	2190978	01	1	118.2	111.6	5.9
027U	4553	2190978	01	2	122.0	112.6	8.4
027U	4553	2190978	01	3	126.8	115.2	10.1
027U	4553	2190978	01	4	132.1	118.8	11.2
027U	4553	2190978	01	5	133.9	118.1	13.3
027U	4553	2190978	01	6	132.5	115.2	15.0
04UK	4715	2195561	01	1	118.6	110.4	7.4
04UK	4715	2195561	01	2	124.3	114.1	9.0
04UK	4715	2195561	01	3	130.9	118.3	10.7
04UK	4715	2195561	01	4	134.0	119.3	12.3
04UK	4715	2195561	01	5	133.2	117.2	13.7

Main PCN	Contract ID	Sample ID	Test #	Seq_Nbr	Wet Density (pcf)	Dry Density (pcf)	Moisture Content (%)
02RX	4838	2210956	03	1	122.4	114.3	7.1
02RX	4838	2210956	03	2	126.0	115.3	9.3
02RX	4838	2210956	03	3	132.8	119.4	11.2
02RX	4838	2210956	03	4	133.9	118.6	12.9
02RX	4838	2210956	03	5	132.8	116.7	13.8

Table 22: DOT-40 points used for compaction curves with a maximum dry unit weight between 120 pcf to 122 pcf.

Main PCN	Contract ID	Sample ID	Test #	Seq_Nbr	Wet Density (pcf)	Dry Density (pcf)	Moisture Content (%)
3834	743	1023635	01	1	120.5	114.7	5.1
3834	743	1023635	01	2	122.8	115.5	6.3
3834	743	1023635	01	3	128.8	118.5	8.7
3834	743	1023635	01	4	133.6	120.6	10.7
3834	743	1023635	01	5	132.9	118.3	12.4
5946	1679	1263658	02	1	122.1	115.0	6.2
5946	1679	1263658	02	2	127.5	118.7	7.4
5946	1679	1263658	02	3	133.5	121.1	10.2
5946	1679	1263658	02	4	133.6	118.5	12.7
5946	1679	1293294	01	1	121.5	113.2	7.4
5946	1679	1293294	01	2	126.4	116.2	8.8
5946	1679	1293294	01	3	132.8	120.1	10.6
5946	1679	1293294	01	4	134.9	120.5	12.0
5946	1679	1293294	01	5	134.1	118.5	13.2
5666	1710	1255868	002	1	125.2	116.2	7.8
5666	1710	1255868	002	2	132.0	120.0	10.0
5666	1710	1255868	002	3	135.5	120.8	12.2
5666	1710	1255868	002	4	134.1	118.3	13.4
6555	1865	1428545	01	1	115.2	109.9	4.9
6555	1865	1428545	01	2	119.2	112.1	6.4
6555	1865	1428545	01	3	123.5	113.6	8.7
6555	1865	1428545	01	4	130.9	117.6	11.3
6555	1865	1428545	01	5	136.7	121.6	12.4
6555	1865	1428545	01	6	133.1	115.4	15.3
5996	2149	1474202	01	1	121.4	113.7	6.7
5996	2149	1474202	01	2	129.4	118.6	9.1
5996	2149	1474202	01	3	133.8	120.9	10.7
5996	2149	1474202	01	4	134.6	119.2	12.9
5996	2149	1474202	01	5	131.4	113.8	15.5
00RV	2449	2082105	01	1	122.4	116.4	5.2
00RV	2449	2082105	01	2	126.8	118.4	7.1
00RV	2449	2082105	01	3	130.4	119.7	9.0
00RV	2449	2082105	01	4	135.6	122.6	10.6
00RV	2449	2082105	01	5	135.8	121.0	12.2
021E	3268	2125943	03	1	122.0	114.1	7.0
021E	3268	2125943	03	2	127.1	116.6	9.0
021E	3268	2125943	03	3	133.5	120.9	10.4

Main PCN	Contract ID	Sample ID	Test #	Seq_Nbr	Wet Density (pcf)	Dry Density (pcf)	Moisture Content (%)
021E	3268	2125943	03	4	134.5	120.3	11.9
021E	3268	2125943	03	5	134.4	119.8	12.2
6179	3335	2108010	01	1	121.7	113.8	6.9
6179	3335	2108010	01	2	127.5	116.7	9.2
6179	3335	2108010	01	3	133.3	120.5	10.6
6179	3335	2108010	01	4	134.5	120.2	11.9
6179	3335	2108010	01	5	133.0	117.5	13.2
00GR	3504	2124079	03	1	122.9	113.0	8.8
00GR	3504	2124079	03	2	128.8	116.7	10.3
00GR	3504	2124079	03	3	134.5	120.3	11.8
00GR	3504	2124079	03	4	134.4	118.1	13.8
6666	3780	2140984	Field02	1	118.1	112.4	5.1
6666	3780	2140984	Field02	2	119.8	112.3	6.7
6666	3780	2140984	Field02	3	123.1	113.9	8.1
6666	3780	2140984	Field02	4	128.1	116.5	9.9
6666	3780	2140984	Field02	5	133.3	119.4	11.6
6666	3780	2140984	Field02	6	135.0	120.6	11.9
02D0	3912	2138565	01	1	125.4	114.2	9.8
02D0	3912	2138565	01	2	133.5	120.3	11.0
02D0	3912	2138565	01	3	134.7	119.8	12.5
02D0	3912	2138565	01	4	132.9	115.6	14.9
02PL	4069	2179351	01	1	120.6	112.3	7.4
02PL	4069	2179351	01	2	125.2	114.8	9.1
02PL	4069	2179351	01	3	131.9	119.5	10.3
02PL	4069	2179351	01	4	134.7	119.5	12.6
02PL	4069	2179351	01	5	134.9	118.5	13.8
02RX	4838	2203985	01	1	117.9	110.9	6.4
02RX	4838	2203985	01	2	124.7	115.4	8.1
02RX	4838	2203985	01	3	132.4	120.2	10.2
02RX	4838	2203985	01	4	136.7	121.3	12.7
02RX	4838	2203985	01	5	133.3	116.6	14.3
02RX	4838	2204566	02	1	121.1	113.7	6.5
02RX	4838	2204566	02	2	125.6	116.2	8.1
02RX	4838	2204566	02	3	130.3	118.3	10.1
02RX	4838	2204566	02	4	134.3	120.4	11.5
02RX	4838	2204566	02	5	134.3	118.5	13.3
035Z	4892	2203783	01	1	117.9	110.9	6.4
035Z	4892	2203783	01	2	124.7	115.4	8.1
035Z	4892	2203783	01	3	132.4	120.2	10.2

Main PCN	Contract ID	Sample ID	Test #	Seq_Nbr	Wet Density (pcf)	Dry Density (pcf)	Moisture Content (%)
035Z	4892	2203783	01	4	136.7	121.3	12.7
035Z	4892	2203783	01	5	133.3	116.6	14.3
035Z	4892	2204479	02	1	121.1	113.7	6.5
035Z	4892	2204479	02	2	125.6	116.2	8.1
035Z	4892	2204479	02	3	130.3	118.3	10.1
035Z	4892	2204479	02	4	134.3	120.4	11.5
035Z	4892	2204479	02	5	134.3	118.5	13.3

Table 23: DOT-40 points used for compaction curves with a maximum dry unit weight between 122 pcf to 124 pcf.

Main PCN	Contract ID	Sample ID	Test #	Seq_Nbr	Wet Density (pcf)	Dry Density (pcf)	Moisture Content (%)
02KH	3139	2099125	01	1	119.0	113.8	4.6
02KH	3139	2099125	01	2	127.5	120.5	5.8
02KH	3139	2099125	01	3	131.4	122.4	7.4
02KH	3139	2099125	01	4	131.5	120.9	8.8
3151	1438	1077471	02	1	120.6	114.5	5.3
3151	1438	1077471	02	2	126.3	118.3	6.8
3151	1438	1077471	02	3	131.1	120.7	8.6
3151	1438	1077471	02	4	136.3	124.1	9.8
3151	1438	1077471	02	5	135.5	122.1	11.0
5893	1860	1432788	IA02	1	124.1	118.0	5.1
5893	1860	1432788	IA02	2	127.8	120.1	6.4
5893	1860	1432788	IA02	3	133.5	122.9	8.7
5893	1860	1432788	IA02	4	137.7	123.6	11.4
6651	2517	1467440	01	1	120.7	114.7	5.3
6651	2517	1467440	01	2	125.9	118.0	6.7
6651	2517	1467440	01	3	133.2	122.1	9.1
6651	2517	1467440	01	4	138.2	124.2	11.3
6651	2517	1467440	01	5	136.5	121.2	12.7
6666	3780	2149071	Field03	1	118.3	112.2	5.4
6666	3780	2149071	Field03	2	124.7	115.9	7.6
6666	3780	2149071	Field03	3	134.9	122.4	10.2
6666	3780	2149071	Field03	4	135.7	121.6	11.6
6666	3780	2149071	Field03	5	134.7	117.1	15.1
I2WD	4511	2177719	01	1	117.7	110.9	6.1
I2WD	4511	2177719	01	2	125.0	116.1	7.6
I2WD	4511	2177719	01	3	128.6	117.6	9.3

Main PCN	Contract ID	Sample ID	Test #	Seq_Nbr	Wet Density (pcf)	Dry Density (pcf)	Moisture Content (%)
I2WD	4511	2177719	01	4	136.4	123.2	10.7
I2WD	4511	2177719	01	5	134.9	124.4	8.5

Table 24: DOT-40 points used for curves with a maximum dry unit weight between 124 pcf to 126 pcf.

Main PCN	Contract ID	Sample ID	Test #	Seq_Nbr	Wet Density (pcf)	Dry Density (pcf)	Moisture Content (%)
6124	978	1024902	Field # 01	1	120.8	117.0	3.3
6124	978	1024902		2	125.7	119.6	5.1
6124	978	1024902	Field # 01	3	131.3	122.9	6.8
6124	978	1024902		4	136.2	124.2	9.7
6124	978	1024902	Field # 01	5	136.1	122.7	11.0
6124	978	1024902		6	134.2	119.8	12.0
6553	1403	1086354	01	1	124.6	118.9	4.9
6553	1403	1086354	01	2	128.6	121.2	6.2
6553	1403	1086354	01	3	132.8	122.5	8.4
6553	1403	1086354	01	4	138.4	124.9	10.8
6553	1403	1086354	01	5	137.4	120.4	14.2
5893	1860	1430366	IA01	1	133.1	123.4	7.9
5893	1860	1430366	IA01	2	135.8	124.3	9.2
5893	1860	1430366	IA01	3	137.1	124.5	10.1
5893	1860	1430366	IA01	4	138.3	124.6	11.0
5893	1860	1430366	IA01	5	136.1	119.9	13.5
6947	1990	1439066	01	1	122.4	116.7	4.9
6947	1990	1439066	01	2	129.6	121.1	7.0
6947	1990	1439066	01	3	136.1	125.2	8.7
6947	1990	1439066	01	4	137.0	121.0	13.2
6947	1990	1439066	01	5	136.1	118.5	14.8
01AW	2385	1462410	01	1	123.9	117.2	5.7
01AW	2385	1462410	01	2	130.4	121.6	7.2
01AW	2385	1462410	01	3	136.3	124.7	9.3
01AW	2385	1462410	01	4	135.7	122.1	11.2
0122	2415	1468287	01	1	122.9	116.0	5.9
0122	2415	1468287	01	2	133.5	122.9	8.7
0122	2415	1468287	01	3	137.0	124.6	9.9
0122	2415	1468287	01	4	135.8	119.3	13.8
6865	4888	2207946	01	1	122.7	117.1	4.7
6865	4888	2207946	01	2	130.5	122.9	6.2
6865	4888	2207946	01	3	134.4	123.8	8.5
6865	4888	2207946	01	4	138.0	124.7	10.7
6865	4888	2207946	01	5	137.6	123.2	11.7
3096	1332	1071758	01	1	119.9	117.8	1.8
3096	1332	1071758	01	2	127.8	123.0	3.9
3096	1332	1071758	01	3	131.9	125.2	5.4

Main PCN	Contract ID	Sample ID	Test #	Seq_Nbr	Wet Density (pcf)	Dry Density (pcf)	Moisture Content (%)
3096	1332	1071758	01	4	133.9	124.6	7.5
6689	1666	1256991	01	1	120.1	114.8	4.6
6689	1666	1256991	01	2	128.2	121.1	5.9
6689	1666	1256991	01	3	134.6	125.0	7.7
6689	1666	1256991	01	4	137.8	125.5	9.7
6555	1865	1449851	04	1	122.9	114.3	7.5
6555	1865	1449851	04	2	129.2	118.0	9.5
6555	1865	1449851	04	3	135.6	122.7	10.5
6555	1865	1449851	04	4	141.6	125.5	12.8
6555	1865	1449851	04	5	141.2	122.7	15.1
1189	2148	1416560	IA01	1	127.1	121.0	5.0
1189	2148	1416560	IA01	2	135.1	125.3	7.8
1189	2148	1416560	IA01	3	138.0	125.5	10.0
1189	2148	1416560	IA01	4	137.7	124.3	10.8
5996	2149	1474911	02	1	125.4	116.5	7.6
5996	2149	1474911	02	2	133.7	122.1	9.5
5996	2149	1474911	02	3	136.6	121.9	12.1
5996	2149	1474911	02	4	134.0	119.1	12.5
5967	2172	1414274	IA01	1	127.1	121.0	5.0
5967	2172	1414274	IA01	2	134.8	125.1	7.8
5967	2172	1414274	IA01	3	138.0	125.5	10.0
5967	2172	1414274	IA01	4	137.7	124.3	10.8
02NG	3488	2102415	01	1	124.1	119.6	3.8
02NG	3488	2102415	01	2	128.2	121.2	5.8
02NG	3488	2102415	01	3	132.9	122.8	8.2
02NG	3488	2102415	01	4	138.5	126.3	9.7
02NG	3488	2102415	01	5	138.8	125.0	11.0
000U	3773	2128124	01	1	120.0	115.4	4.0
000U	3773	2128124	01	2	123.6	117.9	4.8
000U	3773	2128124	01	3	127.3	120.0	6.1
000U	3773	2128124	01	4	133.5	124.5	7.2
000U	3773	2128124	01	5	136.5	125.9	8.4
000U	3773	2128124	01	6	134.4	123.2	9.1

Table 25: DOT-40 points used for compaction curves with a maximum dry unit weight between 126 pcf to 128 pcf.

Main PCN	Contract ID	Sample ID	Test #	Seq_Nbr	Wet Density (pcf)	Dry Density (pcf)	Moisture Content (%)
0566	952	1077254	01	1	123.0	117.9	4.3
0566	952	1077254	01	2	130.6	123.3	5.9
0566	952	1077254	01	3	134.3	125.0	7.4
0566	952	1077254	01	4	122.9	113.3	8.4
6124	978	1019292	02	1	126.8	120.6	5.1
6124	978	1019292	02	2	136.4	126.6	7.7
6124	978	1019292	02	3	137.0	125.6	9.1
6124	978	1019292	02	4	136.5	123.8	10.3
4793	1053	1030365	02	1	132.3	123.1	7.5
4793	1053	1030365	02	2	139.0	126.7	9.7
4793	1053	1030365	02	3	141.0	127.0	11.1
4793	1053	1030365	02	4	140.6	125.2	12.3
5637	1193	1043515	01	1	118.7	113.8	4.3
5637	1193	1043515	01	2	121.9	115.1	5.9
5637	1193	1043515	01	3	131.6	121.6	8.3
5637	1193	1043515	01	4	138.1	126.2	9.5
5637	1193	1043515	01	5	138.5	124.8	11.0
5637	1193	1043515	01	6	137.9	121.6	13.4
5881	1197	1054567	1	1	118.0	115.2	2.5
5881	1197	1054567	1	2	124.4	118.9	4.6
5881	1197	1054567	1	3	133.2	124.5	7.0
5881	1197	1054567	1	4	138.9	126.8	9.6
5881	1197	1054567	1	5	138.4	124.5	11.1
1245	1847	1404333	01	1	122.6	117.3	4.5
1245	1847	1404333	01	2	128.6	120.8	6.4
1245	1847	1404333	01	3	135.3	125.0	8.2
1245	1847	1404333	01	4	140.6	126.6	11.1
1245	1847	1404333	01	5	137.4	120.4	14.1
4460	2416	1478797	03	1	121.3	115.7	4.8
4460	2416	1478797	03	2	134.1	123.0	9.1
4460	2416	1478797	03	3	140.7	126.9	10.8
4460	2416	1478797	03	4	139.7	123.8	12.9
022E	4074	2188570	01	1	117.1	114.0	2.7
022E	4074	2188570	01	2	124.5	119.8	4.0
022E	4074	2188570	01	3	133.2	125.7	5.9
022E	4074	2188570	01	4	136.7	126.3	8.2
04D0	4548	2188262	IA01	1	130.9	123.6	5.9

Main PCN	Contract ID	Sample ID	Test #	Seq_Nbr	Wet Density (pcf)	Dry Density (pcf)	Moisture Content (%)
04D0	4548	2188262	IA01	2	135.0	126.0	7.1
04D0	4548	2188262	IA01	3	137.6	126.6	8.7
04D0	4548	2188262	IA01	4	134.9	122.7	9.9
5858	1218	1046249	01	1	131.1	121.7	7.7
5858	1218	1046249	01	2	139.5	127.2	9.7
5858	1218	1046249	01	3	140.6	123.6	13.7
5858	1218	1046249	01	4	139.7	121.4	15.0
021K	3882	2155027	01	1	125.6	120.6	4.1
021K	3882	2155027	01	2	130.4	123.1	5.9
021K	3882	2155027	01	3	137.5	127.4	7.9
021K	3882	2155027	01	4	139.2	127.0	9.6
021K	3882	2155027	01	5	138.0	124.7	10.7
02QR	4524	2189354	01	1	125.0	120.1	4.0
02QR	4524	2189354	01	2	131.5	124.2	5.9
02QR	4524	2189354	01	3	137.2	126.1	8.7
02QR	4524	2189354	01	4	141.7	128.7	10.1
02QR	4524	2189354	01	5	141.4	127.1	11.2

Table 26: DOT-40 points used for compaction curves with a maximum dry unit weight between 128 pcf to 130 pcf.

Main PCN	Contract ID	Sample ID	Test #	Seq_Nbr	Wet Density (pcf)	Dry Density (pcf)	Moisture Content (%)
5636	911	1017378	02	1	130.0	121.8	6.7
5636	911	1017378	02	2	139.8	128.7	8.7
5636	911	1017378	02	3	142.6	128.6	10.9
5636	911	1017378	02	4	139.8	124.8	12.0
6440	912	1007190	1	1	127.8	122.0	4.8
6440	912	1007190	1	2	135.2	128.0	5.6
6440	912	1007190	1	3	134.8	126.4	6.6
6440	912	1007190	1	4	130.8	121.6	7.5
5635	955	1019413	01	1	130.0	121.8	6.7
5635	955	1019413	01	2	139.8	128.7	8.7
5635	955	1019413	01	3	142.6	128.6	10.9
5635	955	1019413	01	4	139.8	124.8	12.0
5956	1146	1039485	01	1	133.2	125.4	6.2
5956	1146	1039485	01	2	138.6	128.4	7.9
5956	1146	1039485	01	3	142.4	127.5	11.7
5956	1146	1039485	01	4	143.6	128.5	11.7
5956	1146	1039485	01	5	143.7	125.6	14.4
5856	1152	1038741	01	1	131.4	121.6	8.0
5856	1152	1038741	01	2	139.7	127.4	9.6
5856	1152	1038741	01	3	142.9	128.2	11.4
5856	1152	1038741	01	4	141.7	125.5	12.9
5854	1169	1049158	02	1	125.2	120.2	4.2
5854	1169	1049158	02	2	131.7	124.0	6.2
5854	1169	1049158	02	3	137.7	127.5	8.0
5854	1169	1049158	02	4	140.9	127.9	10.2
5854	1169	1049158	02	5	138.9	124.4	11.6
5627	1363	1100342	02	1	121.7	116.8	4.2
5627	1363	1100342	02	2	129.4	122.2	6.0
5627	1363	1100342	02	3	136.4	126.6	7.7
5627	1363	1100342	02	4	140.6	128.1	9.8
5627	1363	1100342	02	5	138.9	124.9	11.2
4699	1614	1277909	01	1	118.1	115.7	2.1
4699	1614	1277909	01	2	125.3	120.7	3.8
4699	1614	1277909	01	3	132.6	126.6	4.8
4699	1614	1277909	01	4	135.8	128.2	6.0
4699	1614	1277909	01	5	135.7	125.9	7.8
5946	1679	1253892	01	1	123.3	118.3	4.2

Main PCN	Contract ID	Sample ID	Test #	Seq_Nbr	Wet Density (pcf)	Dry Density (pcf)	Moisture Content (%)
5946	1679	1253892	01	2	131.3	123.3	6.5
5946	1679	1253892	01	3	139.9	128.7	8.7
5946	1679	1253892	01	4	140.4	126.9	10.7
5946	1679	1253892	01	5	137.7	123.8	11.2
5558	1742	1261606	01	1	128.4	120.5	6.5
5558	1742	1261606	01	2	136.4	126.2	8.1
5558	1742	1261606	01	3	141.2	128.3	10.1
5558	1742	1261606	01	4	138.8	123.9	12.1
6555	1865	1442944	02	1	123.9	119.8	3.4
6555	1865	1442944	02	2	129.7	123.6	4.9
6555	1865	1442944	02	3	136.5	128.9	5.9
6555	1865	1442944	02	4	137.1	127.6	7.4
6555	1865	1442944	02	5	138.3	127.2	8.7
6555	1865	1442947	03	1	122.1	117.5	4.0
6555	1865	1442947	03	2	126.1	120.6	4.6
6555	1865	1442947	03	3	131.3	123.4	6.4
6555	1865	1442947	03	4	136.5	127.1	7.4
6555	1865	1442947	03	5	138.4	127.8	8.3
5586	2103	1467177	01	1	123.9	122.8	0.9
5586	2103	1467177	01	2	127.4	123.6	3.0
5586	2103	1467177	01	3	134.0	127.4	5.1
5586	2103	1467177	01	4	136.7	127.4	7.2
003T	2145	1416841	IA01	1	121.7	118.5	2.6
003T	2145	1416841	IA01	2	128.7	123.0	4.6
003T	2145	1416841	IA01	3	136.1	127.7	6.6
003T	2145	1416841	IA01	4	138.1	124.6	10.9
00S3	2165	1461515	01	1	122.7	118.4	3.6
00S3	2165	1461515	01	2	129.5	122.5	5.8
00S3	2165	1461515	01	3	136.9	127.0	7.8
00S3	2165	1461515	01	4	141.4	128.5	10.1
00S3	2165	1461515	01	5	140.5	124.7	12.6
4460	2416	1476917	02	1	127.0	120.9	5.0
4460	2416	1476917	02	2	131.7	124.3	5.9
4460	2416	1476917	02	3	138.8	128.3	8.2
4460	2416	1476917	02	4	140.4	127.8	9.9
5649	2427	2068606	Field01	1	128.7	122.1	5.5
5649	2427	2068606	Field01	2	135.5	125.5	8.0
5649	2427	2068606	Field01	3	141.4	128.8	9.8
5649	2427	2068606	Field01	4	138.9	123.8	12.2

Main PCN	Contract ID	Sample ID	Test #	Seq_Nbr	Wet Density (pcf)	Dry Density (pcf)	Moisture Content (%)
00Z6	3246	2086228	01	1	128.2	123.0	4.3
00Z6	3246	2086228	01	2	134.4	126.7	6.1
00Z6	3246	2086228	01	3	140.4	130.1	7.9
00Z6	3246	2086228	01	4	141.3	128.6	9.9
00Z6	3246	2086228	01	5	140.1	126.3	10.9
I1MU	3248	2083448	01	1	127.6	119.3	7.0
I1MU	3248	2083448	01	2	134.3	123.9	8.4
I1MU	3248	2083448	01	3	141.2	128.0	10.3
I1MU	3248	2083448	01	4	142.8	127.5	12.0
01KY	3342	2091131	01	1	125.7	120.5	4.3
01KY	3342	2091131	01	2	131.2	123.3	6.4
01KY	3342	2091131	01	3	138.9	127.8	8.6
01KY	3342	2091131	01	4	140.9	128.1	10.0
01KY	3342	2091131	01	5	139.7	125.0	11.8
02NP	3490	2103796	01	1	131.8	126.1	4.5
02NP	3490	2103796	01	2	138.4	129.5	6.8
02NP	3490	2103796	01	3	140.9	129.4	8.9
02NP	3490	2103796	01	4	141.0	128.3	9.9
5656	3556	2120459	IA01	1	130.5	123.1	6.0
5656	3556	2120459	IA01	2	136.9	126.4	8.3
5656	3556	2120459	IA01	3	140.7	129.2	9.0
5656	3556	2120459	IA01	4	137.2	124.1	10.5
010Q	3608	2141800	01	1	127.1	119.6	6.3
010Q	3608	2141800	01	2	136.1	125.9	8.1
010Q	3608	2141800	01	3	141.7	129.5	9.4
010Q	3608	2141800	01	4	140.9	126.6	11.3
01D9	3638	2108446	01	1	124.5	120.6	3.2
01D9	3638	2108446		2	129.3	122.9	5.2
01D9	3638	2108446	01	3	135.9	126.4	7.6
01D9	3638	2108446		4	140.7	129.3	8.8
01D9	3638	2108446	01	5	139.8	125.9	11.0
01T6	3662	2135692	01	1	130.5	125.0	4.4
01T6	3662	2135692	01	2	135.7	127.4	6.5
01T6	3662	2135692	01	3	140.5	129.6	8.4
01T6	3662	2135692	01	4	141.5	128.7	9.9
01T6	3662	2135692	01	5	141.3	127.1	11.2
033V	3827	2155333	01	1	129.1	123.0	4.9
033V	3827	2155333	01	2	136.4	128.7	6.0
033V	3827	2155333	01	3	138.5	129.8	6.8

Main PCN	Contract ID	Sample ID	Test #	Seq_Nbr	Wet Density (pcf)	Dry Density (pcf)	Moisture Content (%)
033V	3827	2155333	01	4	137.3	126.8	8.3
021K	3882	2155028	02	1	126.5	120.3	5.2
021K	3882	2155028	02	2	134.1	124.4	7.9
021K	3882	2155028	02	3	141.3	129.3	9.3
021K	3882	2155028	02	4	137.3	123.8	10.9
0255	3915	2145668	01	1	133.7	123.4	8.3
0255	3915	2145668	01	2	142.3	128.9	10.4
0255	3915	2145668	01	3	143.0	127.4	12.3
0255	3915	2145668	01	4	141.8	125.6	12.9
00D0	3980	2173471	01	1	124.4	120.9	2.9
00D0	3980	2173471	01	2	130.3	124.7	4.5
00D0	3980	2173471	01	3	136.9	128.6	6.5
00D0	3980	2173471	01	4	135.3	124.9	8.4
034S	4176	2202584	01	1	127.0	122.1	4.0
034S	4176	2202584	01	2	133.9	126.4	5.9
034S	4176	2202584	01	3	139.7	128.9	8.3
034S	4176	2202584	01	4	141.4	128.3	10.2
034S	4176	2202584	01	5	140.9	125.4	12.3
6963	4322	2169903	IA01	1	135.0	128.6	5.0
6963	4322	2169903	IA01	2	135.4	127.1	6.5
6963	4322	2169903	IA01	3	137.4	128.2	7.2
6963	4322	2169903	IA01	4	139.4	129.0	8.1
6963	4322	2169903	IA01	5	138.5	125.8	10.1
01RP	4426	2205871	IA01	1	129.1	122.3	5.5
01RP	4426	2205871	IA01	2	138.8	128.9	7.7
01RP	4426	2205871	IA01	3	140.4	128.7	9.1
01RP	4426	2205871	IA01	4	139.3	126.9	9.8
036J	4432	2188548	01	1	125.4	120.4	4.1
036J	4432	2188548	01	2	130.0	122.5	6.1
036J	4432	2188548	01	3	136.1	126.0	8.0
036J	4432	2188548	01	4	140.0	127.8	9.6
036J	4432	2188548	01	5	142.6	128.1	11.4
036J	4432	2188548	01	6	142.4	125.4	13.5
037L	4435	2189535	01	1	131.2	126.0	4.2
037L	4435	2189535	01	2	136.5	128.4	6.4
037L	4435	2189535	01	3	141.4	130.3	8.5
037L	4435	2189535	01	4	141.7	128.5	10.3
037L	4435	2189535	01	5	138.6	123.1	12.7
038X	4518	2185993	01	1	122.9	117.0	5.0

Main PCN	Contract ID	Sample ID	Test #	Seq_Nbr	Wet Density (pcf)	Dry Density (pcf)	Moisture Content (%)
038X	4518	2185993	01	2	132.2	122.7	7.7
038X	4518	2185993	01	3	138.6	127.3	8.9
038X	4518	2185993	01	4	141.5	129.2	9.5
038X	4518	2185993	01	5	141.9	128.2	10.7
038X	4518	2185993	01	6	139.5	124.7	11.9
041D	4570	2201706	01	1	124.5	118.8	4.8
041D	4570	2201706	01	2	133.8	126.2	6.0
041D	4570	2201706	01	3	137.6	126.7	8.6
041D	4570	2201706	01	4	142.4	129.3	10.1
041D	4570	2201706	01	5	140.4	125.8	11.6
041D	4570	2202223	02	1	130.1	122.6	6.1
041D	4570	2202223	02	2	137.8	127.7	7.9
041D	4570	2202223	02	3	142.0	129.7	9.6
041D	4570	2202223	02	4	141.2	127.3	10.9
6488	4587	2220342	IA01	1	123.7	119.2	3.8
6488	4587	2220342	IA01	2	128.7	122.0	5.5
6488	4587	2220342	IA01	3	136.3	127.6	6.8
6488	4587	2220342	IA01	4	136.0	125.1	8.7
035E	5109	2225302	IA01	1	132.9	126.5	5.1
035E	5109	2225302	IA01	2	138.1	129.7	6.5
035E	5109	2225302	IA01	3	139.5	128.3	8.7
035E	5109	2225302	IA01	4	139.1	126.4	10.1
04F8	5521	2230390	01	1	128.1	121.5	5.4
04F8	5521	2230390	01	2	136.1	126.7	7.4
04F8	5521	2230390	01	3	142.2	129.3	9.9
04F8	5521	2230390	01	4	141.1	127.6	10.6

Table 27: DOT-40 points used for compaction curves with a maximum dry unit weight between 130 pcf to 132 pcf.

Main PCN	Contract ID	Sample ID	Test #	Seq_Nbr	Wet Density (pcf)	Dry Density (pcf)	Moisture Content (%)
4084	910	1011274	1	1	136.8	127.4	7.4
4084	910	1011274	1	2	140.9	129.5	8.8
4084	910	1011274	1	3	143.4	129.9	10.4
4084	910	1011274	1	4	140.7	126.0	11.7
5636	911	1008686	01	1	131.6	124.3	5.9
5636	911	1008686	01	2	141.4	130.8	8.1
5636	911	1008686	01	3	144.2	131.9	9.3
5636	911	1008686	01	4	142.4	128.7	10.6
5823	967	1009253	IAS01	1	136.8	127.4	7.4
5823	967	1009253	IAS01	2	140.9	129.3	8.9
5823	967	1009253	IAS01	3	143.5	130.0	10.4
5823	967	1009253	IAS01	4	141.0	126.1	11.8
077N	968	1020592	01	1	135.6	127.6	6.2
077N	968	1020592	01	2	138.1	129.1	7.0
077N	968	1020592	01	3	143.6	131.5	9.2
077N	968	1020592	01	4	143.7	130.6	10.0
597M	1004	1020707	Field-01	1	129.2	124.7	3.6
597M	1004	1020707	Field-01	2	136.0	128.7	5.6
597M	1004	1020707	Field-01	3	142.6	132.7	7.5
597M	1004	1020707	Field-01	4	143.3	130.5	9.8
597M	1004	1020707	Field-01	5	142.9	128.2	11.5
4793	1053	1029175	01	1	133.4	126.1	5.7
4793	1053	1029175	01	2	139.1	130.0	7.0
4793	1053	1029175	01	3	142.5	131.1	8.7
4793	1053	1029175	01	4	141.5	128.8	9.9
5994	1078	1035175	01	1	130.8	124.5	5.1
5994	1078	1035175		2	136.4	128.3	6.4
5994	1078	1035175	01	3	125.0	120.4	3.8
5994	1078	1035175		4	141.0	130.7	7.8
5994	1078	1035175	01	5	142.2	130.0	9.4
5837	1134	1053354	02	1	128.8	122.3	5.3
5837	1134	1053354	02	2	138.3	129.1	7.1
5837	1134	1053354	02	3	143.6	131.3	9.4
5837	1134	1053354	02	4	142.0	127.6	11.3
5837	1134	1058909	03	1	126.7	120.5	5.1
5837	1134	1058909	03	2	133.7	125.1	6.9
5837	1134	1058909	03	3	141.6	130.4	8.6
5837	1134	1058909	03	4	141.5	127.8	10.7

Main PCN	Contract ID	Sample ID	Test #	Seq_Nbr	Wet Density (pcf)	Dry Density (pcf)	Moisture Content (%)
5626	1162	1116208	01	1	127.3	120.9	5.3
5626	1162	1116208	01	2	135.2	127.2	6.3
5626	1162	1116208	01	3	140.9	130.7	7.8
5626	1162	1116208	01	4	140.1	127.6	9.8
6241	1200	1057515	01	1	136.2	128.4	6.1
6241	1200	1057515	01	2	140.6	130.5	7.8
6241	1200	1057515	01	3	143.0	131.3	9.0
6241	1200	1057515	01	4	143.3	129.1	11.0
5624	1222	1124681	01BC	1	130.5	124.7	4.6
5624	1222	1124681	01BC	2	137.2	129.1	6.3
5624	1222	1124681	01BC	3	142.6	131.8	8.2
5624	1222	1124681	01BC	4	141.0	128.0	10.2
3731	1352	1092195	Field # 1	1	128.1	123.7	3.5
3731	1352	1092195	Field # 1	2	136.5	129.1	5.7
3731	1352	1092195	Field # 1	3	142.0	131.1	8.3
3731	1352	1092195	Field # 1	4	141.7	128.1	10.6
5627	1363	1096632	01	1	124.6	119.3	4.5
5627	1363	1096632	01	2	133.6	125.4	6.5
5627	1363	1096632	01	3	141.4	130.4	8.4
5627	1363	1096632	01	4	142.5	130.2	9.5
5627	1363	1096632	01	5	140.5	126.5	11.1
5627	1363	1127524	03	1	126.1	120.9	4.3
5627	1363	1127524	03	2	134.5	126.6	6.2
5627	1363	1127524	03	3	141.2	130.0	8.6
5627	1363	1127524	03	4	141.3	128.8	9.7
5627	1363	1260941	04	1	126.7	121.5	4.2
5627	1363	1260941	04	2	133.7	126.1	6.0
5627	1363	1260941	04	3	140.9	130.1	8.3
5627	1363	1260941	04	4	141.2	128.3	10.1
5627	1363	1260941	04	5	139.5	126.2	10.5
5622	1404	1078612	01	1	130.1	123.6	5.3
5622	1404	1078612	01	2	137.0	128.5	6.6
5622	1404	1078612	01	3	142.2	130.7	8.8
5622	1404	1078612	01	4	140.2	127.3	10.1
519N	1532	1131150	01	1	126.6	119.4	6.0
519N	1532	1131150	01	2	137.0	127.6	7.3
519N	1532	1131150	01	3	137.2	127.1	8.0
519N	1532	1131150	01	4	144.3	131.3	9.9
519N	1532	1131150	01	5	144.0	127.6	12.9
4824	1598	1272903	IA01	1	134.8	127.1	6.0

Main PCN	Contract ID	Sample ID	Test #	Seq_Nbr	Wet Density (pcf)	Dry Density (pcf)	Moisture Content (%)
4824	1598	1272903	IA01	2	138.8	130.1	6.7
4824	1598	1272903	IA01	3	142.3	131.8	8.0
4824	1598	1272903	IA01	4	140.4	128.6	9.2
0370	1801	1412746	IA01	1	124.5	117.9	5.6
0370	1801	1412746	IA01	2	139.7	128.2	9.0
0370	1801	1412746	IA01	3	138.1	125.7	9.8
0370	1801	1412746	IA01	4	139.5	125.8	10.9
00FG	1814	1328572	01	1	134.5	125.4	7.3
00FG	1814	1328572	01	2	141.3	130.4	8.4
00FG	1814	1328572	01	3	142.0	128.6	10.4
00FG	1814	1328572	01	4	142.0	128.2	10.7
5992	1845	1403763	01	1	126.1	120.6	4.6
5992	1845	1403763	01	2	134.5	126.7	6.2
5992	1845	1403763	01	3	142.4	131.4	8.4
5992	1845	1403763	01	4	143.3	130.1	10.2
5992	1845	1403763	01	5	140.7	126.4	11.3
00S0	2074	1435861	02	1	133.6	125.7	6.3
00S0	2074	1435861	02	2	141.6	130.8	8.3
00S0	2074	1435861	02	3	144.1	131.5	9.6
00S0	2074	1435861	02	4	142.7	128.5	11.0
00S0	2074	1451148	01	1	139.5	130.9	6.5
00S0	2074	1451148	01	2	142.8	131.7	8.4
00S0	2074	1451148	01	3	143.9	131.3	9.5
00S0	2074	1451148	01	4	142.3	128.5	10.7
5632	2111	1445811	01	1	120.9	116.9	3.4
5632	2111	1445811	01	2	131.4	124.4	5.7
5632	2111	1445811	01	3	138.1	128.1	7.8
5632	2111	1445811	01	4	143.8	131.1	9.7
5632	2111	1445811	01	5	139.8	124.8	12.1
00KY	2125	2096314	IA01	1	130.4	124.6	4.7
00KY	2125	2096314	IA01	2	139.8	130.6	7.0
00KY	2125	2096314	IA01	3	143.3	132.0	8.6
00KY	2125	2096314	IA01	4	142.0	128.6	10.5
001D	2135	1422646	Field01	1	126.2	121.3	4.1
001D	2135	1422646	Field01	2	133.0	124.4	6.9
001D	2135	1422646	Field01	3	143.4	134.8	6.4
001D	2135	1422646	Field01	4	144.3	131.6	9.7
001D	2135	1422646	Field01	5	142.2	127.5	11.5
4168	2171	1463126	01	1	125.7	120.7	4.2
4168	2171	1463126	01	2	132.0	124.4	6.1

Main PCN	Contract ID	Sample ID	Test #	Seq_Nbr	Wet Density (pcf)	Dry Density (pcf)	Moisture Content (%)
4168	2171	1463126	01	3	139.7	129.7	7.8
4168	2171	1463126	01	4	141.7	129.2	9.7
4168	2171	1463126	01	5	139.9	125.7	11.3
00UU	2178	1445640	IA01	1	141.5	131.1	7.9
00UU	2178	1445640	IA01	2	142.3	129.4	10.0
00UU	2178	1445640	IA01	3	146.6	131.6	11.4
00UU	2178	1445640	IA01	4	145.6	128.6	13.2
6194	2284	1483414	01	1	126.6	121.5	4.2
6194	2284	1483414	01	2	136.0	128.1	6.2
6194	2284	1483414	01	3	142.5	132.4	7.6
6194	2284	1483414	01	4	143.3	131.0	9.4
6194	2284	1483414	01	5	142.8	128.2	11.4
6194	2284	1483686	01	1	126.1	120.5	4.6
6194	2284	1483686	01	2	133.2	125.2	6.3
6194	2284	1483686	01	3	141.3	130.6	8.2
6194	2284	1483686	01	4	142.7	129.5	10.2
6194	2284	1483686	01	5	141.2	126.8	11.4
010U	2304	1438089	01	1	123.9	119.0	4.2
010U	2304	1438089	01	2	135.0	127.2	6.1
010U	2304	1438089	01	3	141.7	131.2	7.9
010U	2304	1438089	01	4	141.5	128.4	10.2
H059	2344	1481286	IA01	1	125.5	118.7	5.7
H059	2344	1481286	IA01	2	131.6	122.7	7.3
H059	2344	1481286	IA01	3	140.8	129.2	9.0
H059	2344	1481286	IA01	4	143.5	129.6	10.7
H059	2344	1481286	IA01	5	137.4	120.6	13.9
00J0	2414	1475127	01	1	130.6	124.9	4.5
00J0	2414	1475127	01	2	138.0	130.0	6.1
00J0	2414	1475127	01	3	143.2	131.4	9.0
00J0	2414	1475127	01	4	143.1	128.3	11.5
0122	2415	1467353	IA01	1	130.4	123.0	6.0
0122	2415	1467353	IA01	2	138.8	128.4	8.1
0122	2415	1467353	IA01	3	143.2	130.6	9.7
0122	2415	1467353	IA01	4	141.9	127.0	11.7
00HA	2436	1469838	01	1	130.2	123.3	5.6
00HA	2436	1469838	01	2	139.2	129.3	7.6
00HA	2436	1469838	01	3	142.0	129.6	9.6
00HA	2436	1469838	01	4	141.5	127.7	10.8
00RV	2449	2088598	03	1	131.6	126.2	4.3
00RV	2449	2088598	03	2	138.9	130.7	6.3

Main PCN	Contract ID	Sample ID	Test #	Seq_Nbr	Wet Density (pcf)	Dry Density (pcf)	Moisture Content (%)
00RV	2449	2088598	03	3	142.9	131.7	8.5
00RV	2449	2088598	03	4	142.0	128.4	10.5
6564	2453	1465370	01	1	132.8	126.3	5.2
6564	2453	1465370	01	2	141.1	131.5	7.3
6564	2453	1465370	01	3	143.1	131.8	8.5
6564	2453	1465370	01	4	140.4	126.5	11.0
6922	2525	1478626	01	1	132.5	125.7	5.3
6922	2525	1478626	01	2	138.1	128.2	7.7
6922	2525	1478626	01	3	143.0	130.9	9.3
6922	2525	1478626	01	4	140.2	125.7	11.6
01AK	2553	1475417	IA02	1	129.0	122.4	5.4
01AK	2553	1475417	IA02	2	133.2	125.9	5.8
01AK	2553	1475417	IA02	3	141.5	131.1	7.9
01AK	2553	1475417	IA02	4	141.6	127.6	11.0
6962	2716	2076871	01	1	133.3	126.1	5.7
6962	2716	2076871	01	2	140.9	130.1	8.2
6962	2716	2076871	01	3	145.0	131.9	9.9
6962	2716	2076871	01	4	143.1	128.8	11.2
00XF	2789	2077299	IA01	1	128.1	122.2	4.8
00XF	2789	2077299	IA01	2	130.9	123.6	5.9
00XF	2789	2077299	IA01	3	135.9	126.9	7.1
00XF	2789	2077299	IA01	4	139.3	125.6	11.0
00XF	2789	2077657	IA02	1	132.0	124.6	6.0
00XF	2789	2077657	IA02	2	137.1	128.1	7.0
00XF	2789	2077657	IA02	3	142.1	131.2	8.3
00XF	2789	2077657	IA02	4	140.8	126.9	10.9
01T4	2931	2086285	01	1	128.8	121.3	6.2
01T4	2931	2086285	01	2	134.6	124.8	7.8
01T4	2931	2086285	01	3	142.7	130.3	9.5
01T4	2931	2086285	01	4	145.8	131.8	10.6
00FI	2966	2085979	01	1	122.2	119.0	2.7
00FI	2966	2085979	01	2	128.0	123.8	3.4
00FI	2966	2085979	01	3	133.7	128.1	4.3
00FI	2966	2085979	01	4	138.2	130.4	6.0
00D1	3077	2089430	01	1	128.9	122.2	5.5
00D1	3077	2089430	01	2	137.3	128.1	7.2
00D1	3077	2089430	01	3	142.8	130.2	9.6
00D1	3077	2089430	01	4	140.0	125.3	11.7
00GU	3171	2103483	01	1	136.8	128.1	6.8
00GU	3171	2103483	01	2	141.0	130.1	8.4

Main PCN	Contract ID	Sample ID	Test #	Seq_Nbr	Wet Density (pcf)	Dry Density (pcf)	Moisture Content (%)
00GU	3171	2103483	01	3	143.3	130.8	9.6
00GU	3171	2103483	01	4	140.9	127.0	10.9
024A	3189	2092510	02	1	130.1	124.9	4.2
024A	3189	2092510	02	2	136.1	127.7	6.6
024A	3189	2092510	02	3	141.8	131.1	8.2
024A	3189	2092510	02	4	141.8	128.9	10.1
6884	3196	2108335	01	1	139.3	126.4	10.2
6884	3196	2108335	01	2	141.6	129.9	9.0
6884	3196	2108335	01	3	119.2	115.3	3.4
6884	3196	2108335	01	4	125.7	120.4	4.4
6884	3196	2108501	02	1	134.5	127.2	5.8
6884	3196	2108501	02	2	140.0	130.2	7.6
6884	3196	2108501	02	3	141.8	130.4	8.7
6884	3196	2108501	02	4	120.4	116.0	3.8
00RL	3202	2100391	01	1	127.0	122.1	4.0
00RL	3202	2100391	01	2	135.0	127.5	5.9
00RL	3202	2100391	01	3	140.9	129.3	8.9
00RL	3202	2100391	01	4	138.8	126.4	9.8
024G	3324	2109472	01	1	125.5	120.8	3.9
024G	3324	2109472	01	2	136.3	128.7	5.9
024G	3324	2109472	01	3	141.4	131.7	7.4
024G	3324	2109472	01	4	142.7	129.8	9.9
024G	3324	2109472	01	5	142.6	129.1	10.4
02D2	3382	2105686	01	1	130.4	125.2	4.1
02D2	3382	2105686	01	2	135.7	127.9	6.1
02D2	3382	2105686	01	3	140.6	130.4	7.9
02D2	3382	2105686	01	4	140.8	128.3	9.7
02N9	3398	2113204	01	1	125.3	119.9	4.6
02N9	3398	2113204	01	2	134.3	126.5	6.1
02N9	3398	2113204	01	3	141.3	130.1	8.6
02N9	3398	2113204	01	4	141.5	127.4	11.0
02QE	3586	2134142	IA01	1	127.2	122.2	4.2
02QE	3586	2134142	IA01	2	133.6	126.1	5.9
02QE	3586	2134142	IA01	3	138.4	129.6	6.8
02QE	3586	2134142	IA01	4	137.1	126.1	8.7
6954	3609	2128693	01	1	130.5	124.4	4.9
6954	3609	2128693	01	2	136.6	128.1	6.7
6954	3609	2128693	01	3	140.9	130.0	8.4
6954	3609	2128693	01	4	142.6	129.5	10.1
02ZK	3642	2129310	Field01	1	124.2	118.7	4.6

Main PCN	Contract ID	Sample ID	Test #	Seq_Nbr	Wet Density (pcf)	Dry Density (pcf)	Moisture Content (%)
02ZK	3642	2129310	Field01	2	133.7	126.0	6.1
02ZK	3642	2129310	Field01	3	140.6	130.1	8.1
02ZK	3642	2129310	Field01	4	143.5	131.0	9.6
6666	3780	2129310	Field01	5	141.0	126.5	11.5
6666	3780	2132005	01	1	125.5	120.4	4.2
6666	3780	2132005	01	2	134.8	126.8	6.3
6666	3780	2132005	01	3	141.1	130.4	8.2
6666	3780	2132005	01	4	142.0	128.1	10.8
02SA	3990	2132005	01	5	139.7	124.5	12.2
02SA	3990	2172465	01	1	127.0	120.4	5.5
02SA	3990	2172465	01	2	136.7	127.6	7.2
02SA	3990	2172465	01	3	142.1	130.3	9.0
02SA	3990	2172465	01	4	140.5	127.6	10.1
02Q1	4076	2177486	01	1	123.5	117.2	5.4
02Q1	4076	2177486	01	2	134.3	126.0	6.6
02Q1	4076	2177486	01	3	142.1	130.4	8.9
02Q1	4076	2177486	01	4	139.3	124.8	11.6
020A	4078	2206213	01	1	131.8	124.3	6.0
020A	4078	2206213	01	2	139.7	129.2	8.1
020A	4078	2206213	01	3	142.9	130.1	9.8
020A	4078	2206213	01	4	141.4	124.1	14.0
01DA	4174	2202341	01	1	130.6	123.8	5.5
01DA	4174	2202341	01	2	139.5	130.2	7.2
01DA	4174	2202341	01	3	143.0	131.1	9.1
01DA	4174	2202341	01	4	141.3	127.7	10.6
00K2	4218	2168559	01	1	129.1	123.5	4.5
00K2	4218	2168559	01	2	136.3	127.5	6.9
00K2	4218	2168559	01	3	142.0	131.2	8.3
00K2	4218	2168559	01	4	141.6	128.4	10.3
026V	4225	2167157	01	1	123.2	118.2	4.2
026V	4225	2167157	01	2	125.6	119.0	5.5
026V	4225	2167157	01	3	133.8	125.2	6.9
026V	4225	2167157	01	4	140.6	129.8	8.4
01QH	4250	2167157	01	5	137.4	124.7	10.2
01QH	4250	2175406	01	1	127.4	124.8	2.0
01QH	4250	2175406	01	2	130.3	125.1	4.1
01QH	4250	2175406	01	3	136.7	129.6	5.5
01QH	4250	2175406	01	4	140.2	129.8	8.0
01TM	4253	2175406	01	5	140.0	125.2	11.8
01TM	4253	2172719	01	1	124.5	118.3	5.2

Main PCN	Contract ID	Sample ID	Test #	Seq_Nbr	Wet Density (pcf)	Dry Density (pcf)	Moisture Content (%)
01TM	4253	2172719	01	2	132.5	124.4	6.5
01TM	4253	2172719	01	3	141.5	130.7	8.3
01TM	4253	2172719	01	4	144.1	131.5	9.6
6649	4259	2172719	01	5	143.8	126.9	13.3
02QR	4524	2192142	02	1	127.4	122.9	3.6
02QR	4524	2192142	02	2	136.9	129.3	5.9
02QR	4524	2192142	02	3	141.0	130.4	8.2
02QR	4524	2192142	02	4	140.4	126.4	11.0
037G	4526	2185997	01	1	123.6	119.1	3.8
037G	4526	2185997	01	2	132.1	124.5	6.1
037G	4526	2185997	01	3	141.0	130.7	7.9
037G	4526	2185997	01	4	140.8	128.5	9.6
026B	4533	2186206	02	1	128.9	122.9	4.9
026B	4533	2186206	02	2	135.3	126.7	6.7
026B	4533	2186206	02	3	141.5	130.3	8.6
026B	4533	2186206	02	4	141.1	128.5	9.8
026B	4533	2188332	01	1	131.3	126.3	4.0
026B	4533	2188332	01	2	135.9	128.5	5.7
026B	4533	2188332	01	3	141.7	131.5	7.8
026B	4533	2188332	01	4	142.9	130.4	9.5
037K	4539	2188332	01	5	140.0	126.1	11.0
037K	4539	2208864	01	1	126.9	120.7	5.1
037K	4539	2208864	01	2	136.1	127.4	6.8
037K	4539	2208864	01	3	143.0	131.1	9.1
037K	4539	2208864	01	4	142.2	128.6	10.5
00YW	4706	2216947	IA01	1	127.7	122.4	4.4
00YW	4706	2216947	IA01	2	135.1	127.5	5.9
00YW	4706	2216947	IA01	3	140.5	130.6	7.6
00YW	4706	2216947	IA01	4	139.2	128.0	8.7
04E1	4909	2214660	IAS01	1	135.5	128.5	5.5
04E1	4909	2214660	IAS01	2	143.0	131.7	8.6
04E1	4909	2214660	IAS01	3	144.1	131.6	9.5
04E1	4909	2214660	IAS01	4	140.5	125.4	12.0
03DL	4986	2229749	01	1	129.5	122.8	5.5
03DL	4986	2229749	01	2	137.3	128.6	6.7
03DL	4986	2229749	01	3	143.5	131.7	9.0
03DL	4986	2229749	01	4	142.2	128.9	10.3
01QS	5127	2222918	01	1	131.4	124.2	5.8
01QS	5127	2222918	01	2	141.0	131.3	7.4
01QS	5127	2222918	01	3	142.7	130.7	9.2

Main PCN	Contract ID	Sample ID	Test #	Seq_Nbr	Wet Density (pcf)	Dry Density (pcf)	Moisture Content (%)
01QS	5127	2222918	01	4	142.5	128.4	11.0
02J1	5149	2229134	01	1	127.7	122.5	4.3
02J1	5149	2229134	01	2	139.5	130.8	6.6
02J1	5149	2229134	01	3	142.5	129.8	9.8
02J1	5149	2229134	01	4	138.8	123.6	12.3

Table 28: DOT-40 points used for compaction curves with a maximum dry unit weight between 132 pcf to 134 pcf.

Main PCN	Contract ID	Sample ID	Test #	Seq_Nbr	Wet Density (pcf)	Dry Density (pcf)	Moisture Content (%)
4795	888	1023682	01 4-pt	1	131.9	124.7	5.8
4795	888	1023682	01 4-pt	2	139.7	130.5	7.0
4795	888	1023682	01 4-pt	3	143.4	132.2	8.5
4795	888	1023682	01 4-pt	4	142.7	130.0	9.8
3834	743	1023644	02	1	128.4	125.2	2.6
3834	743	1023644	02	2	134.0	127.6	5.0
3834	743	1023644	02	3	140.0	129.2	8.4
3834	743	1023644	02	4	147.3	134.6	9.5
3834	743	1023644	02	5	145.5	131.5	10.6
5856	1152	1039482	02	1	131.6	124.4	5.8
5856	1152	1039482	02	2	139.4	130.3	7.0
5856	1152	1039482	02	3	143.3	132.0	8.5
5856	1152	1039482	02	4	142.5	129.8	9.8
5854	1169	1038931	01	1	132.8	125.7	5.6
5854	1169	1038931	01	2	141.6	131.6	7.6
5854	1169	1038931	01	3	143.7	131.6	9.2
5854	1169	1038931	01	4	142.2	128.0	11.1
6280	1475	1116123	01	1	140.9	130.9	7.6
6280	1475	1116123	01	2	144.2	132.0	9.3
6280	1475	1116123	01	3	143.6	129.8	10.6
6280	1475	1116123	01	4	134.6	126.7	6.3
6974	2025	1460282	01	1	134.5	127.0	5.9
6974	2025	1460282	01	2	142.5	132.3	7.7
6974	2025	1460282	01	3	142.9	129.9	10.0
6974	2025	1460282	01	4	141.4	127.2	11.2
6463	2351	2067606	Field01	1	129.7	122.1	6.2
6463	2351	2067606	Field01	2	140.7	130.4	7.9
6463	2351	2067606	Field01	3	145.0	131.0	10.7
6463	2351	2067606	Field01	4	139.9	123.6	13.2
00GU	3171	2104269	02	1	124.2	120.2	3.3
00GU	3171	2104269	02	2	134.5	128.1	5.0
00GU	3171	2104269	02	3	142.0	132.4	7.3
00GU	3171	2104269	02	4	143.4	131.0	9.5
00GU	3171	2104269	02	5	140.9	125.0	12.8
02K8	3305	2088198	01	1	126.2	122.0	3.5
02K8	3305	2088198	01	2	135.4	127.8	6.0
02K8	3305	2088198	01	3	140.5	130.8	7.4

Main PCN	Contract ID	Sample ID	Test #	Seq_Nbr	Wet Density (pcf)	Dry Density (pcf)	Moisture Content (%)
02K8	3305	2088198	01	4	144.8	132.1	9.6
02K8	3305	2088198	01	5	143.0	127.1	12.5
002B	3537	2131461	01	1	127.5	122.5	4.1
002B	3537	2131461	01	2	134.8	127.9	5.3
002B	3537	2131461	01	3	142.4	132.4	7.6
002B	3537	2131461	01	4	142.6	131.2	8.6
0371	3758	2126795	01	1	133.2	127.5	4.5
0371	3758	2126795	01	2	139.7	130.8	6.8
0371	3758	2126795	01	3	143.6	132.0	8.8
0371	3758	2126795	01	4	141.1	127.4	10.7
0254	3772	2135461	03	1	131.3	125.1	5.0
0254	3772	2135461	03	2	141.1	131.6	7.2
0254	3772	2135461	03	3	142.5	131.3	8.5
0254	3772	2135461	03	4	138.8	130.2	6.6
025X	4224	2160444	02	1	131.9	126.7	4.1
025X	4224	2160444	02	2	136.3	128.5	6.0
025X	4224	2160444	02	3	142.8	132.4	7.9
025X	4224	2160444	02	4	144.4	131.5	9.8
025X	4224	2160444	02	5	144.7	129.7	11.5
040K	4569	2190688	01	1	127.2	121.1	5.1
040K	4569	2190688	01	2	136.7	128.8	6.1
040K	4569	2190688	01	3	141.7	130.3	8.8
040K	4569	2190688	01	4	139.8	126.4	10.6
03C6	4724	2186339	01	1	134.7	126.7	6.4
03C6	4724	2186339	01	2	138.1	128.9	7.1
03C6	4724	2186339	01	3	144.6	132.2	9.4
03C6	4724	2186339	01	4	143.9	129.9	10.8
038E	4829	2207613	IA01	1	123.1	118.4	3.9
038E	4829	2207613	IA01	2	134.7	127.7	5.5
038E	4829	2207613	IA01	3	142.1	132.8	7.1
038E	4829	2207613	IA01	4	141.9	130.4	8.8
038E	4829	2207613	IA01	5	139.9	126.8	10.3
B015	5024	2204758	01	1	130.5	124.6	4.8
B015	5024	2204758	01	2	136.9	129.4	5.8
B015	5024	2204758	01	3	142.1	132.4	7.3
B015	5024	2204758	01	4	141.4	130.1	8.7
B015	5024	2204758	01	5	138.6	126.4	9.7
I3R3	5182	2220021	01	1	127.3	121.1	5.1
I3R3	5182	2220021	01	2	139.7	130.3	7.2

Main PCN	Contract ID	Sample ID	Test #	Seq_Nbr	Wet Density (pcf)	Dry Density (pcf)	Moisture Content (%)
I3R3	5182	2220021	01	3	144.2	132.1	9.2
I3R3	5182	2220021	01	4	144.1	130.6	10.3
675R	914	1068200	01	1	129.3	122.9	5.2
675R	914	1068200	01	2	138.0	129.0	7.0
675R	914	1068200	01	3	143.6	132.4	8.4
675R	914	1068200	01	4	143.2	129.7	10.5
4185	925	1012188	01	1	128.8	122.1	5.4
4185	925	1012188	01	2	138.8	129.2	7.4
4185	925	1012188	01	3	145.3	132.7	9.5
4185	925	1012188	01	4	144.6	129.5	11.7
3913	1093	1049793	02	1	125.9	123.2	2.2
3913	1093	1049793	02	2	130.2	125.2	4.0
3913	1093	1049793	02	3	136.4	129.3	5.6
3913	1093	1049793	02	4	143.1	133.1	7.5
3913	1093	1049793	02	5	144.8	132.4	9.4
5837	1134	1035951	01	1	128.1	121.8	5.2
5837	1134	1035951	01	2	139.5	130.4	7.0
5837	1134	1035951	01	3	144.3	132.1	9.2
5837	1134	1035951	01	4	142.1	128.9	10.2
X101	1154	1070477	01	1	123.1	119.8	2.8
X101	1154	1070477	01	2	131.0	125.7	4.2
X101	1154	1070477	01	3	139.5	132.0	5.7
X101	1154	1070477	01	4	141.9	132.6	7.0
X101	1154	1070477	01	5	141.8	131.1	8.1
5822	1163	1056626	01	1	137.6	129.0	6.7
5822	1163	1056626	01	2	142.9	131.9	8.3
5822	1163	1056626	01	3	144.6	132.7	9.0
5822	1163	1056626	01	4	142.7	129.4	10.3
5854	1169	1052107	03	1	133.8	128.2	4.4
5854	1169	1052107	03	2	140.9	132.2	6.6
5854	1169	1052107	03	3	143.8	133.5	7.8
5854	1169	1052107	03	4	141.6	128.6	10.1
6198	1198	1077420	IA01	1	143.4	128.9	11.2
6198	1198	1077420	IA01	2	142.7	131.9	8.2
6198	1198	1077420	IA01	3	130.8	123.4	6.1
6198	1198	1077420	IA01	4	145.4	132.1	10.0
4876	1251	1058780	001	1	135.7	130.5	4.0
4876	1251	1058780	001	2	141.4	133.2	6.2
4876	1251	1058780	001	3	143.4	132.5	8.2

Main PCN	Contract ID	Sample ID	Test #	Seq_Nbr	Wet Density (pcf)	Dry Density (pcf)	Moisture Content (%)
4876	1251	1058780	001	4	143.7	131.2	9.6
5855	1354	1073996	01	1	128.0	122.6	4.3
5855	1354	1073996	01	2	136.1	127.9	6.4
5855	1354	1073996	01	3	143.6	132.6	8.3
5855	1354	1073996	01	4	142.9	129.0	10.8
5855	1354	1079252	02	1	131.3	125.7	4.5
5855	1354	1079252	02	2	139.8	131.5	6.3
5855	1354	1079252	02	3	144.1	132.6	8.7
5855	1354	1079252	02	4	143.8	130.5	10.2
6681	1406	1078961	ia01	1	141.3	132.9	6.3
6681	1406	1078961	ia01	2	142.5	132.5	7.5
6681	1406	1078961	ia01	3	145.7	132.6	9.9
6681	1406	1078961	ia01	4	145.3	130.9	11.0
6681	1406	1078961	ia01	5	136.5	130.6	4.5
568N	1549	1128196	01	1	131.1	127.3	3.0
568N	1549	1128196	01	2	138.6	132.3	4.8
568N	1549	1128196	01	3	141.8	133.1	6.5
568N	1549	1128196	01	4	143.7	133.2	7.9
5899	1595	1260328	01	1	130.5	125.9	3.7
5899	1595	1260328	01	2	138.3	130.5	5.9
5899	1595	1260328	01	3	143.2	133.0	7.6
5899	1595	1260328	01	4	143.9	131.9	9.0
5899	1595	1260328	01	5	142.9	129.3	10.5
4699	1614	1301527	01	1	131.0	124.4	5.3
4699	1614	1301527	01	2	140.9	130.7	7.8
4699	1614	1301527	01	3	146.0	133.7	9.2
4699	1614	1301527	01	4	145.7	131.7	10.6
5960	1662	1294521	Field01	1	124.6	121.0	3.0
5960	1662	1294521	Field01	2	134.9	128.6	4.9
5960	1662	1294521	Field01	3	144.1	134.8	6.9
5960	1662	1294521	Field01	4	142.9	131.4	8.7
6689	1666	1259765	02	1	132.3	125.9	5.1
6689	1666	1259765	02	2	141.8	132.5	7.0
6689	1666	1259765	02	3	145.7	133.9	8.9
6689	1666	1259765	02	4	144.5	131.5	9.9
5631	1684	1260403	01	1	123.0	116.4	5.7
5631	1684	1260403	01	2	131.2	122.0	7.5
5631	1684	1260403	01	3	143.9	132.0	9.0
5631	1684	1260403	01	4	141.5	127.7	10.8

Main PCN	Contract ID	Sample ID	Test #	Seq_Nbr	Wet Density (pcf)	Dry Density (pcf)	Moisture Content (%)
6452	1714	1296891	01	1	129.6	122.9	5.5
6452	1714	1296891	01	2	138.5	129.2	7.2
6452	1714	1296891	01	3	144.9	132.8	9.1
6452	1714	1296891	01	4	142.6	128.3	11.2
6937	1779	1404335	01	1	133.2	126.6	5.2
6937	1779	1404335	01	2	140.8	131.8	6.8
6937	1779	1404335	01	3	144.8	133.1	8.8
6937	1779	1404335	01	4	142.2	128.3	10.8
6176	1924	1423003	01	1	135.6	128.2	5.8
6176	1924	1423003	01	2	143.7	133.7	7.5
6176	1924	1423003	01	3	143.7	131.4	9.4
6176	1924	1423003	01	4	142.2	127.9	11.2
4319	1952	1460688	01	1	128.9	123.0	4.8
4319	1952	1460688	01	2	134.7	127.1	6.0
4319	1952	1460688	01	3	142.1	132.1	7.6
4319	1952	1460688	01	4	142.9	129.0	10.8
6690	1954	1431648	01	1	132.8	126.9	4.7
6690	1954	1431648	01	2	143.8	132.6	8.4
6690	1954	1431648	01	3	146.0	133.2	9.7
6690	1954	1431648	01	4	147.4	133.3	10.5
6690	1954	1431648	01	5	147.1	130.1	13.1
10EY	2054	1430604	01	1	136.6	130.1	5.0
10EY	2054	1430604	01	2	143.0	133.7	7.0
10EY	2054	1430604	01	3	142.1	130.0	9.3
10EY	2054	1430604	01	4	123.2	119.3	3.3
6563	2101	1416575	01	1	132.7	125.6	5.6
6563	2101	1416575	01	2	142.3	132.2	7.6
6563	2101	1416575	01	3	144.7	132.1	9.5
6563	2101	1416575	01	4	141.7	126.3	12.2
00U8	2122	1480874	01	1	126.4	121.7	3.9
00U8	2122	1480874	01	2	136.2	130.2	4.7
00U8	2122	1480874	01	3	142.2	133.1	6.8
00U8	2122	1480874	01	4	143.4	133.2	7.6
6324	2235	2077273	IA01	1	124.7	119.4	4.5
6324	2235	2077273	IA01	2	140.7	132.1	6.5
6324	2235	2077273	IA01	3	142.4	132.9	7.2
6324	2235	2077273	IA01	4	141.1	129.5	8.9
011J	2241	1413652	01	1	133.0	125.9	5.6
011J	2241	1413652	01	2	143.6	132.8	8.1

Main PCN	Contract ID	Sample ID	Test #	Seq_Nbr	Wet Density (pcf)	Dry Density (pcf)	Moisture Content (%)
011J	2241	1413652	01	3	146.5	133.7	9.5
011J	2241	1413652	01	4	142.4	128.3	11.0
5319	2360	2213226	01	1	129.9	123.7	5.0
5319	2360	2213226	01	2	138.3	129.6	6.8
5319	2360	2213226	01	3	143.8	132.8	8.3
5319	2360	2213226	01	4	142.2	129.4	9.9
00YD	2375	1430142	Field01	1	131.1	124.5	5.3
00YD	2375	1430142	Field01	2	143.0	132.8	7.7
00YD	2375	1430142	Field01	3	145.3	132.7	9.5
00YD	2375	1430142	Field01	4	141.5	126.7	11.7
4460	2416	1480106	04	1	130.7	124.4	5.1
4460	2416	1480106	04	2	133.4	125.7	6.2
4460	2416	1480106	04	3	140.7	130.9	7.5
4460	2416	1480106	04	4	144.7	132.9	8.9
5649	2427	1476517	Field # 01	1	125.9	120.5	4.5
5649	2427	1476517	Field # 01	2	136.5	127.7	6.9
5649	2427	1476517	Field # 01	3	143.8	132.3	8.7
5649	2427	1476517	Field # 01	4	140.5	125.9	11.6
1976	2437	2111893	01	1	126.9	121.1	4.7
1976	2437	2111893	01	2	137.3	129.1	6.3
1976	2437	2111893	01	3	143.8	133.3	7.9
1976	2437	2111893	01	4	143.0	129.7	10.3
00RW	2558	2137920	02	1	132.4	126.9	4.4
00RW	2558	2137920	02	2	138.9	131.1	5.9
00RW	2558	2137920	02	3	143.2	132.2	8.3
00RW	2558	2137920	02	4	142.3	128.7	10.5
H060	2608	1482211	01	1	130.1	122.5	6.2
H060	2608	1482211	01	2	141.1	131.0	7.7
H060	2608	1482211	01	3	144.3	130.6	10.5
H060	2608	1482211	01	4	140.6	124.5	12.9
6716	2633	2070709	01	1	134.8	128.6	4.9
6716	2633	2070709	01	2	143.4	133.5	7.4
6716	2633	2070709	01	3	143.5	131.4	9.3
6716	2633	2070709	01	4	138.8	125.4	10.7
6962	2716	2080667	02	1	125.1	121.1	3.3
6962	2716	2080667	02	2	135.3	128.5	5.3
6962	2716	2080667	02	3	143.5	133.7	7.3

Main PCN	Contract ID	Sample ID	Test #	Seq_Nbr	Wet Density (pcf)	Dry Density (pcf)	Moisture Content (%)
6962	2716	2080667	02	4	143.1	131.3	9.0
00X4	2804	2097623	01	1	121.4	118.3	2.6
00X4	2804	2097623	01	2	129.8	124.4	4.3
00X4	2804	2097623	01	3	136.3	129.1	5.6
00X4	2804	2097623	01	4	142.1	132.8	7.0
00X4	2804	2097623	01	5	141.7	130.7	8.5
01X1	2876	1483150	01	1	130.6	124.9	4.6
01X1	2876	1483150	01	2	138.9	130.4	6.5
01X1	2876	1483150	01	3	143.9	133.4	7.8
01X1	2876	1483150	01	4	143.7	131.0	9.7
01T2	2953	2083162	01	1	132.0	125.6	5.1
01T2	2953	2083162	01	2	142.8	132.9	7.5
01T2	2953	2083162	01	3	144.5	133.6	8.2
01T2	2953	2083162	01	4	141.2	128.1	10.2
00FI	2966	2085782	01	1	134.7	130.1	3.6
00FI	2966	2085782	01	2	140.1	132.9	5.4
00FI	2966	2085782	01	3	142.8	134.0	6.6
00FI	2966	2085782	01	4	127.1	123.6	2.8
024A	3189	2092501	01	1	128.8	123.5	4.2
024A	3189	2092501	01	2	136.1	128.2	6.1
024A	3189	2092501	01	3	143.2	132.5	8.0
024A	3189	2092501	01	4	141.7	128.9	9.9
02FW	3280	2087013	Field01	1	127.8	123.7	3.3
02FW	3280	2087013	Field01	2	136.5	129.7	5.3
02FW	3280	2087013	Field01	3	140.9	131.0	7.5
02FW	3280	2087013	Field01	4	145.3	134.1	8.4
02FW	3280	2087013	Field01	5	142.6	128.0	11.4
6559	3373	2108751	01	1	131.3	125.4	4.7
6559	3373	2108751	01	2	139.6	130.8	6.7
6559	3373	2108751	01	3	145.3	133.8	8.6
6559	3373	2108751	01	4	141.7	128.0	10.8
01X8	3560	2108581	Field # 1	1	135.7	127.4	6.5
01X8	3560	2108581	Field # 1	2	143.5	132.9	8.0
01X8	3560	2108581	Field # 1	3	144.9	130.8	10.8
01X8	3560	2108581	Field # 1	4	143.5	128.2	12.0
02P2	3597	2132715	01	1	132.5	126.3	4.9
02P2	3597	2132715	01	2	141.3	131.8	7.2

Main PCN	Contract ID	Sample ID	Test #	Seq_Nbr	Wet Density (pcf)	Dry Density (pcf)	Moisture Content (%)
02P2	3597	2132715	01	3	144.6	133.0	8.7
02P2	3597	2132715	01	4	141.7	128.6	10.1
01T6	3662	2136529	02	1	131.1	126.3	3.8
01T6	3662	2136529	02	2	138.7	131.1	5.8
01T6	3662	2136529	02	3	144.4	133.9	7.8
01T6	3662	2136529	02	4	142.9	130.2	9.8
03BE	3765	2125872	01	1	133.1	127.6	4.3
03BE	3765	2125872	01	2	138.7	130.2	6.5
03BE	3765	2125872	01	3	143.9	132.7	8.4
03BE	3765	2125872	01	4	142.7	129.5	10.2
03BP	3774	2129296	03	1	134.8	129.8	3.8
03BP	3774	2129296	03	2	140.9	133.4	5.6
03BP	3774	2129296	03	3	143.7	133.4	7.7
03BP	3774	2129296	03	4	142.7	130.1	9.7
I2BQ	3796	2116158	01	1	129.5	124.2	4.2
I2BQ	3796	2116158	01	2	137.5	129.5	6.2
I2BQ	3796	2116158	01	3	143.5	133.3	7.6
I2BQ	3796	2116158	01	4	142.9	131.1	9.0
3106	3826	2134143	01	1	126.4	121.5	4.0
3106	3826	2134143	01	2	129.9	123.8	5.0
3106	3826	2134143	01	3	137.9	129.1	6.8
3106	3826	2134143	01	4	141.2	126.9	11.3
00CP	3879	2150910	01	1	131.7	125.3	5.1
00CP	3879	2150910	01	2	143.5	133.4	7.6
00CP	3879	2150910	01	3	144.6	132.1	9.5
00CP	3879	2150910	01	4	144.5	129.0	12.0
01R5	3896	2169747	IA01	1	137.3	130.4	5.3
01R5	3896	2169747	IA01	2	142.6	133.2	7.1
01R5	3896	2169747	IA01	3	144.4	132.3	9.1
01R5	3896	2169747	IA01	4	138.6	125.1	10.8
03HK	3938	2159117	03	1	130.9	125.3	4.5
03HK	3938	2159117	03	2	137.8	130.2	5.9
03HK	3938	2159117	03	3	144.0	133.5	7.9
03HK	3938	2159117	03	4	139.3	124.2	12.2
01FG	3973	2139352	Field # 01	1	128.9	122.8	4.9
01FG	3973	2139352	Field # 01	2	139.0	129.9	7.0
01FG	3973	2139352	Field # 01	3	144.5	132.7	8.9

Main PCN	Contract ID	Sample ID	Test #	Seq_Nbr	Wet Density (pcf)	Dry Density (pcf)	Moisture Content (%)
01FG	3973	2139352	Field # 01	4	144.3	130.6	10.5
02DC	4029	2139994	01	1	135.3	128.5	5.3
02DC	4029	2139994	01	2	140.8	132.0	6.7
02DC	4029	2139994	01	3	141.9	129.6	9.4
02DC	4029	2139994	01	4	122.5	121.7	0.7
042Q	4969	2207958	01	1	129.3	124.4	4.0
042Q	4969	2207958	01	2	138.3	130.5	5.9
042Q	4969	2207958	01	3	144.0	133.9	7.6
042Q	4969	2207958	01	4	141.6	129.1	9.7
035U	4839	2206302	01	1	130.9	125.7	4.2
035U	4839	2206302	01	2	136.9	129.3	5.9
035U	4839	2206302	01	3	142.7	132.7	7.5
035U	4839	2206302	01	4	142.0	129.7	9.5
04PQ	4669	2205312	IA01	1	127.5	122.9	3.7
04PQ	4669	2205312	IA01	2	133.1	126.3	5.4
04PQ	4669	2205312	IA01	3	139.6	130.8	6.7
04PQ	4669	2205312	IA01	4	142.8	133.1	7.3
04PQ	4669	2205312	IA01	5	131.2	119.8	9.5
020K	4681	2210177	IA01	1	128.4	123.2	4.2
020K	4681	2210177	IA01	2	137.7	130.7	5.4
020K	4681	2210177	IA01	3	142.3	133.0	7.0
020K	4681	2210177	IA01	4	142.0	131.4	8.0
02Q1	4076	2173817	03	1	136.3	128.6	6.0
02Q1	4076	2173817	03	2	144.1	133.4	8.0
02Q1	4076	2173817	03	3	144.2	131.5	9.7
02Q1	4076	2173817	03	4	141.0	126.5	11.5
03JD	4103	2154415	01	1	131.6	125.1	5.2
03JD	4103	2154415	01	2	141.5	132.0	7.2
03JD	4103	2154415	01	3	144.3	132.9	8.5
03JD	4103	2154415	01	4	140.3	126.5	10.8
022X	4178	2178179	IA01	1	135.8	130.7	3.9
022X	4178	2178179	IA01	2	136.9	125.5	9.1
022X	4178	2178179	IA01	3	137.8	127.7	8.0
022X	4178	2178179	IA01	4	140.8	132.4	6.3
025X	4224	2160289	01	1	131.1	125.6	4.3
025X	4224	2160289	01	2	136.5	128.9	5.9
025X	4224	2160289	01	3	144.5	133.4	8.3
025X	4224	2160289	01	4	143.1	130.6	9.5
025Z	4345	2192347	02	1	134.3	127.1	5.7

Main PCN	Contract ID	Sample ID	Test #	Seq_Nbr	Wet Density (pcf)	Dry Density (pcf)	Moisture Content (%)
025Z	4345	2192347	02	2	142.9	132.5	7.8
025Z	4345	2192347	02	3	143.9	131.8	9.2
025Z	4345	2192347	02	4	141.7	127.4	11.2
037L	4435	2189006	01	1	128.0	123.3	3.8
037L	4435	2189006	01	2	137.7	130.1	5.9
037L	4435	2189006	01	3	143.4	133.1	7.8
037L	4435	2189006	01	4	143.2	130.8	9.4
037K	4539	2188965	02	1	132.5	127.0	4.3
037K	4539	2188965	02	2	139.4	131.2	6.2
037K	4539	2188965	02	3	143.3	132.2	8.4
037K	4539	2188965	02	4	140.4	127.6	10.0
03L6	4630	2185899	01	1	130.9	125.8	4.0
03L6	4630	2185899	01	2	139.3	131.3	6.0
03L6	4630	2185899	01	3	143.8	133.2	8.0
03L6	4630	2185899	01	4	141.0	128.5	9.7
02WN	3636	2179444	01	1	126.2	121.2	4.1
02WN	3636	2179444	01	2	133.8	125.9	6.3
02WN	3636	2179444	01	3	143.0	132.3	8.1
02WN	3636	2179444	01	4	145.3	132.3	9.8
6678	2639	2076074	01	1	131.7	128.0	2.8
6678	2639	2076074	01	2	138.3	131.8	4.9
6678	2639	2076074	01	3	141.5	131.1	7.9
6678	2639	2076074	01	4	141.4	129.3	9.3

Table 29: DOT-40 points used for compaction curves with a maximum dry unit weight between 134 pcf to 136 pcf.

Main PCN	Contract ID	Sample ID	Test #	Seq_Nbr	Wet Density (pcf)	Dry Density (pcf)	Moisture Content (%)
5770	1005	1039193	01	1	136.8	132.5	3.3
5770	1005	1039193	01	2	139.6	132.9	5.1
5770	1005	1039193	01	3	143.2	135.2	5.9
5770	1005	1039193	01	4	143.2	133.7	7.1
5770	1005	1039193	01	5	141.9	133.8	6.0
5852	1055	1015210	01	1	134.5	127.4	5.6
5852	1055	1015210	01	2	142.9	133.5	7.1
5852	1055	1015210	01	3	145.3	132.4	9.7
5852	1055	1015210	01	4	142.5	128.5	11.0
6035	1073	1052292	Field#1	1	125.7	121.3	3.7
6035	1073	1052292	Field#1	2	134.9	128.2	5.2
6035	1073	1052292	Field#1	3	144.8	135.3	7.0
6035	1073	1052292	Field#1	4	146.0	133.3	9.5
6035	1073	1052292	Field#1	5	143.9	128.7	11.8
6379	1330	1076206	01	1	135.7	126.5	7.3
6379	1330	1076206	01	2	141.4	131.0	8.0
6379	1330	1076206	01	3	147.3	135.4	8.8
6379	1330	1076206	01	4	146.8	134.4	9.2
6379	1330	1076206	01	5	146.6	133.2	10.1
3151	1438	1073817	01	1	133.8	129.5	3.3
3151	1438	1073817	01	2	140.2	133.4	5.1
3151	1438	1073817	01	3	143.5	133.5	7.5
3151	1438	1073817	01	4	142.8	131.7	8.4
6242	1491	1123197	01	1	128.9	123.1	4.7
6242	1491	1123197	01	2	137.7	129.6	6.3
6242	1491	1123197	01	3	144.5	133.8	8.0
6242	1491	1123197	01	4	143.6	129.9	10.5
4824	1598	1322738	01	1	132.9	126.6	5.0
4824	1598	1322738	01	2	138.3	129.9	6.4
4824	1598	1322738	01	3	144.9	134.5	7.7
4824	1598	1322738	01	4	143.1	131.4	8.9
I747	1843	1289646	001	1	139.5	131.6	6.0
I747	1843	1289646	001	2	143.4	133.8	7.1
I747	1843	1289646	001	3	146.3	134.9	8.5
I747	1843	1289646	001	4	143.2	130.3	10.0
00RR	1879	1305221	01	1	134.8	128.3	5.1
00RR	1879	1305221	01	2	144.1	134.1	7.4

Main PCN	Contract ID	Sample ID	Test #	Seq_Nbr	Wet Density (pcf)	Dry Density (pcf)	Moisture Content (%)
00RR	1879	1305221	01	3	144.0	131.4	9.6
00RR	1879	1305221	01	4	142.1	127.8	11.2
4438	1921	1444575	1	1	132.2	127.7	3.5
4438	1921	1444575	1	2	140.7	134.3	4.8
4438	1921	1444575	1	3	143.6	133.9	7.3
4438	1921	1444575	1	4	145.1	134.3	8.0
6701	2021	1449921	01	1	129.1	127.0	1.7
6701	2021	1449921	01	2	129.8	125.7	3.3
6701	2021	1449921	01	3	137.8	131.9	4.5
6701	2021	1449921	01	4	137.5	129.3	6.4
6477	2041	1407988	01	1	130.7	124.0	5.5
6477	2041	1407988	01	2	135.1	125.9	7.4
6477	2041	1407988	01	3	143.9	132.1	9.0
6477	2041	1407988	01	4	143.9	128.9	11.6
3782	2428	2103427	Field01	1	131.4	124.5	5.6
3782	2428	2103427	Field01	2	140.4	131.6	6.6
3782	2428	2103427	Field01	3	144.5	132.2	9.3
3782	2428	2103427	Field01	4	142.4	128.8	10.5
6461	2430	2067613	01	1	126.9	124.6	1.8
6461	2430	2067613	01	2	136.8	132.3	3.4
6461	2430	2067613	01	3	141.1	134.4	5.0
6461	2430	2067613	01	4	140.5	131.3	7.0
00GW	2440	1471974	01	1	135.0	129.2	4.5
00GW	2440	1471974	01	2	141.6	132.6	6.8
00GW	2440	1471974	01	3	145.5	134.5	8.1
00GW	2440	1471974	01	4	143.6	130.0	10.4
00RV	2449	2087435	02	1	136.2	130.6	4.3
00RV	2449	2087435	02	2	142.5	134.3	6.1
00RV	2449	2087435	02	3	143.0	132.6	7.8
00RV	2449	2087435	02	4	141.0	128.3	9.9
003J	2461	1468071	IA01	1	132.8	127.1	4.5
003J	2461	1468071	IA01	2	141.4	132.8	6.4
003J	2461	1468071	IA01	3	144.5	133.3	8.5
003J	2461	1468071	IA01	4	142.9	130.7	9.4
00RW	2558	2136538	01	1	132.4	127.0	4.2
00RW	2558	2136538	01	2	140.7	132.9	5.9
00RW	2558	2136538	01	3	144.4	134.0	7.7
00RW	2558	2136538	01	4	142.0	129.6	9.6
00WY	2640	2067321	01	1	135.2	130.5	3.7

Main PCN	Contract ID	Sample ID	Test #	Seq_Nbr	Wet Density (pcf)	Dry Density (pcf)	Moisture Content (%)
00WY	2640	2067321	01	2	142.2	134.6	5.7
00WY	2640	2067321	01	3	143.8	134.2	7.1
00WY	2640	2067321	01	4	142.8	130.7	9.3
6437	2117	1464795	01	1	128.4	125.1	2.6
6437	2117	1464795	01	2	143.2	134.8	6.3
6437	2117	1464795	01	3	144.6	133.4	8.4
6437	2117	1464795	01	4	141.4	128.1	10.3
6253	2151	1440952	IA01	1	141.1	131.5	7.3
6253	2151	1440952	IA01	2	142.4	132.1	7.8
6253	2151	1440952	IA01	3	147.3	134.9	9.2
6253	2151	1440952	IA01	4	140.4	126.6	10.9
6324	2235	2078490	IA02	1	130.0	123.2	5.5
6324	2235	2078490	IA02	2	138.4	129.4	7.0
6324	2235	2078490	IA02	3	142.9	132.6	7.8
6324	2235	2078490	IA02	4	139.3	126.2	10.4
01QN	2920	2086132	02	1	130.8	125.3	4.4
01QN	2920	2086132	02	2	140.6	132.5	6.1
01QN	2920	2086132	02	3	145.4	134.8	7.9
01QN	2920	2086132	02	4	144.0	131.4	9.5
021E	3268	2106283	01	1	137.3	130.0	5.6
021E	3268	2106283	01	2	143.4	134.3	6.8
021E	3268	2106283	01	3	144.8	132.7	9.1
021E	3268	2106283	01	4	144.5	131.3	10.1
01KY	3342	2093748	02	1	132.5	125.7	5.4
01KY	3342	2093748	02	2	138.9	130.2	6.7
01KY	3342	2093748	02	3	146.6	134.6	8.9
01KY	3342	2093748	02	4	142.2	129.0	10.3
02NE	3486	2102285	01	1	132.4	126.9	4.3
02NE	3486	2102285	01	2	142.9	134.4	6.3
02NE	3486	2102285	01	3	144.9	133.8	8.3
02NE	3486	2102285	01	4	142.4	129.4	10.0
02VL	3506	2105982	01	1	125.6	121.2	3.6
02VL	3506	2105982	01	2	131.4	125.3	4.9
02VL	3506	2105982	01	3	143.8	133.6	7.7
02VL	3506	2105982	01	4	146.1	134.1	8.9
02VL	3506	2105982	01	5	142.9	128.7	11.1
02QD	3539	2145738	01	1	131.7	125.1	5.3
02QD	3539	2145738	01	2	143.0	133.6	7.0
02QD	3539	2145738	01	3	145.3	132.7	9.4

Main PCN	Contract ID	Sample ID	Test #	Seq_Nbr	Wet Density (pcf)	Dry Density (pcf)	Moisture Content (%)
02QD	3539	2145738	01	4	142.3	125.8	13.1
01RV	3568	2152672	IA01	1	134.6	127.7	5.4
01RV	3568	2152672	IA01	2	142.0	133.2	6.6
01RV	3568	2152672	IA01	3	140.8	129.6	8.6
01RV	3568	2152672	IA01	4	126.2	121.8	3.6
H034	3599	2132225	01	1	133.1	125.9	5.7
H034	3599	2132225	01	2	142.1	132.8	7.0
H034	3599	2132225	01	3	145.1	133.1	9.0
H034	3599	2132225	01	4	144.5	131.9	9.6
H034	3599	2132401	02	1	136.2	127.8	6.5
H034	3599	2132401	02	2	144.3	134.0	7.7
H034	3599	2132401	02	3	144.5	131.2	10.1
H034	3599	2132401	02	4	141.5	127.6	10.9
01T6	3662	2135698	01	1	133.6	128.1	4.3
01T6	3662	2135698	01	2	142.0	133.5	6.3
01T6	3662	2135698	01	3	144.3	133.1	8.4
01T6	3662	2135698	01	4	141.3	128.7	9.8
03BP	3774	2128723	01	1	135.9	130.2	4.4
03BP	3774	2128723	01	2	142.4	133.8	6.4
03BP	3774	2128723	01	3	143.3	132.2	8.4
03BP	3774	2128723	01	4	137.9	125.7	9.7
03BP	3774	2128803	02	1	135.6	130.2	4.1
03BP	3774	2128803	02	2	142.1	134.1	6.0
03BP	3774	2128803	02	3	142.7	132.3	7.8
03BP	3774	2128803	02	4	141.1	128.3	9.9
01D3	3910	2136435	Field#01	1	136.2	129.3	5.3
01D3	3910	2136435	Field#01	2	143.9	134.4	7.1
01D3	3910	2136435	Field#01	3	144.3	131.6	9.7
01D3	3910	2136435	Field#01	4	143.7	130.6	10.0
0255	3915	2146134	02	1	134.3	127.0	5.7
0255	3915	2146134	02	2	143.7	133.0	8.0
0255	3915	2146134	02	3	146.6	134.5	9.0
0255	3915	2146134	02	4	145.3	131.4	10.6
021B	4084	2165374	01	1	138.9	132.8	4.6
021B	4084	2165374	01	2	142.4	134.2	6.1
021B	4084	2165374	01	3	139.1	129.6	7.3
021B	4084	2165374	01	4	128.1	124.4	3.0
025Z	4345	2202746	03	1	129.5	124.6	4.0
025Z	4345	2202746	03	2	138.3	130.6	6.0

Main PCN	Contract ID	Sample ID	Test #	Seq_Nbr	Wet Density (pcf)	Dry Density (pcf)	Moisture Content (%)
025Z	4345	2202746	03	3	143.8	134.1	7.3
025Z	4345	2202746	03	4	144.9	132.4	9.4
025Z	4345	2202746	03	5	142.2	129.1	10.2
I2TX	4397	2182904	IA01	1	128.8	123.5	4.3
I2TX	4397	2182904	IA01	2	138.8	131.0	5.9
I2TX	4397	2182904	IA01	3	146.0	134.7	8.4
I2TX	4397	2182904	IA01	4	144.2	131.0	10.1
02CZ	4645	2204559	01	1	134.2	127.3	5.4
02CZ	4645	2204559	01	2	142.6	132.5	7.6
02CZ	4645	2204559	01	3	146.1	134.2	8.8
02CZ	4645	2204559	01	4	143.4	130.7	9.7
03QH	4702	2201260	01	1	137.7	130.6	5.4
03QH	4702	2201260	01	2	145.9	134.9	8.2
03QH	4702	2201260	01	3	146.1	134.1	9.0
03QH	4702	2201260	01	4	142.3	128.5	10.8
035A	4833	2205858	01	1	114.5	109.8	4.2
035A	4833	2205858	01	2	137.1	129.1	6.2
035A	4833	2205858	01	3	143.9	133.8	7.6
035A	4833	2205858	01	4	143.4	130.2	10.2
04GN	4952	2220090	01	1	132.0	126.2	4.6
04GN	4952	2220090	01	2	141.1	132.2	6.7
04GN	4952	2220090	01	3	145.2	133.4	8.8
04GN	4952	2220090	01	4	142.9	130.2	9.8
I3PJ	5084	2213132	01	1	125.2	122.9	1.9
I3PJ	5084	2213132	01	2	131.5	127.2	3.4
I3PJ	5084	2213132	01	3	136.0	129.5	5.0
I3PJ	5084	2213132	01	4	143.5	134.8	6.4
I3PJ	5084	2213132	01	5	144.8	134.5	7.7
315N	1171	1030715	01	1	125.4	121.9	2.9
315N	1171	1030715	01	2	136.2	130.5	4.3
315N	1171	1030715	01	3	140.8	134.3	4.8
315N	1171	1030715	01	4	141.5	135.1	4.7
6897	1257	1054586	1	1	134.7	128.2	5.0
6897	1257	1054586	1	2	144.9	135.1	7.3
6897	1257	1054586	1	3	146.4	133.5	9.7
6897	1257	1054586	1	4	143.7	129.2	11.3
1948	1663	1262759	02	1	136.9	130.6	4.8
1948	1663	1262759	02	2	143.8	134.4	7.0
1948	1663	1262759	02	3	146.5	134.2	9.2

Main PCN	Contract ID	Sample ID	Test #	Seq_Nbr	Wet Density (pcf)	Dry Density (pcf)	Moisture Content (%)
1948	1663	1262759	02	4	142.9	129.7	10.2
5865	1671	1255917	01	1	141.7	133.6	6.0
5865	1671	1255917	01	2	146.0	136.3	7.1
5865	1671	1255917	01	3	144.8	134.2	7.9
5865	1671	1255917	01	4	143.7	132.0	8.9
5865	1671	1255917	01	5	136.8	131.3	4.2
6481	1888	1437147	IA01	1	124.6	121.2	2.8
6481	1888	1437147	IA01	2	132.3	127.2	4.0
6481	1888	1437147	IA01	3	144.5	134.9	7.1
6481	1888	1437147	IA01	4	146.2	135.8	7.7
6481	1888	1437147	IA01	5	145.1	134.1	8.2
6146	1933	1404236	01	1	139.1	132.7	4.8
6146	1933	1404236	01	2	129.0	125.6	2.7
6146	1933	1404236	01	3	142.8	133.8	6.7
6146	1933	1404236	01	4	140.7	131.2	7.2
6181	1951	1434381	01	1	128.8	122.5	5.1
6181	1951	1434381	01	2	141.4	132.8	6.5
6181	1951	1434381	01	3	145.4	133.7	8.8
6181	1951	1434381	01	4	142.5	128.3	11.1
6702	1955	1439391	01	1	127.0	124.5	2.0
6702	1955	1439391	01	2	130.7	126.4	3.4
6702	1955	1439391	01	3	141.6	134.8	5.1
6702	1955	1439391	01	4	139.5	130.8	6.7
3783	2110	1464928	Field02	1	130.9	124.5	5.1
3783	2110	1464928	Field02	2	144.2	135.0	6.9
3783	2110	1464928	Field02	3	146.6	134.7	8.8
3783	2110	1464928	Field02	4	143.0	127.9	11.8
00UU	2178	1450590	IA02	1	129.9	123.5	5.2
00UU	2178	1450590	IA02	2	141.6	130.9	8.1
00UU	2178	1450590	IA02	3	148.4	134.9	10.0
00UU	2178	1450590	IA02	4	146.6	130.4	12.5
6788	2269	1455103	01	1	132.9	126.5	5.1
6788	2269	1455103	01	2	140.8	131.6	7.0
6788	2269	1455103	01	3	144.9	131.9	9.8
6788	2269	1455103	01	4	143.1	130.0	10.1
000Z	2369	1466756	01	1	124.4	120.9	2.9
000Z	2369	1466756	01	2	140.8	133.6	5.4
000Z	2369	1466756	01	3	143.6	135.2	6.3
000Z	2369	1466756	01	4	142.8	135.3	5.6

Main PCN	Contract ID	Sample ID	Test #	Seq_Nbr	Wet Density (pcf)	Dry Density (pcf)	Moisture Content (%)
000Y	2925	2067934	01	1	136.7	131.0	4.4
000Y	2925	2067934	01	2	145.1	135.8	6.9
000Y	2925	2067934	01	3	145.6	133.9	8.7
000Y	2925	2067934	01	4	145.2	131.2	10.7
00FI	2966	2093486	02	1	136.3	131.3	3.9
00FI	2966	2093486	02	2	143.6	135.3	6.2
00FI	2966	2093486	02	3	142.8	132.3	8.0
00FI	2966	2093486	02	4	140.1	128.2	9.3
01DH	2985	2083512	01	1	132.6	127.3	4.1
01DH	2985	2083512	01	2	139.6	131.5	6.2
01DH	2985	2083512	01	3	144.8	134.7	7.5
01DH	2985	2083512	01	4	145.4	133.2	9.1
02A2	3205	2146553	01	1	129.1	126.5	2.1
02A2	3205	2146553	01	2	137.1	131.9	3.9
02A2	3205	2146553	01	3	144.5	135.7	6.4
02A2	3205	2146553	01	4	143.5	132.9	8.0
00GR	3504	2108181	01	1	137.6	132.2	4.1
00GR	3504	2108181	01	2	143.9	135.7	6.0
00GR	3504	2108181	01	3	144.9	134.2	8.0
00GR	3504	2108181	01	4	142.3	130.1	9.3
01TF	3520	2152663	01	1	130.1	124.7	4.3
01TF	3520	2152663	01	2	138.0	130.8	5.5
01TF	3520	2152663	01	3	144.2	135.0	6.8
01TF	3520	2152663	01	4	144.0	134.1	7.4
02KL	3596	2126809	01	1	125.9	122.7	2.6
02KL	3596	2126809	01	2	128.9	124.2	3.8
02KL	3596	2126809	01	3	139.4	131.5	6.0
02KL	3596	2126809	01	4	143.8	135.2	6.4
02KL	3596	2126809	01	5	142.5	131.0	8.7
02P2	3597	2154959	02	1	133.2	125.6	6.0
02P2	3597	2154959	02	2	139.0	129.7	7.2
02P2	3597	2154959	02	3	146.8	134.5	9.1
02P2	3597	2154959	02	4	146.6	131.1	11.8
01QR	3783	2129630	01	1	126.2	122.1	3.4
01QR	3783	2129630	01	2	135.4	128.7	5.2
01QR	3783	2129630	01	3	141.8	133.2	6.4
01QR	3783	2129630	01	4	146.1	135.6	7.8
01QR	3783	2129630	01	5	147.1	134.5	9.4
3106	3826	2134559	02	1	131.6	126.0	4.5

Main PCN	Contract ID	Sample ID	Test #	Seq_Nbr	Wet Density (pcf)	Dry Density (pcf)	Moisture Content (%)
3106	3826	2134559	02	2	136.4	128.8	5.9
3106	3826	2134559	02	3	143.5	133.7	7.3
3106	3826	2134559	02	4	142.9	129.7	10.2
033V	3827	2132472	01	1	126.8	124.3	2.0
033V	3827	2132472	01	2	130.2	126.1	3.2
033V	3827	2132472	01	3	138.7	132.0	5.0
033V	3827	2132472	01	4	145.1	135.1	7.5
033V	3827	2132472	01	5	146.2	134.7	8.6
00ZH	4024	2155063	01	1	134.2	127.0	5.7
00ZH	4024	2155063	01	2	139.8	131.4	6.4
00ZH	4024	2155063	01	3	146.7	134.8	8.8
00ZH	4024	2155063	01	4	143.5	130.4	10.1
02Q6	4242	2191307	01	1	133.6	127.3	4.9
02Q6	4242	2191307	01	2	142.4	134.3	6.0
02Q6	4242	2191307	01	3	145.0	134.5	7.8
02Q6	4242	2191307	01	4	143.6	130.4	10.1
025Z	4345	2191455	01	1	132.9	126.5	5.0
025Z	4345	2191455	01	2	143.3	134.0	7.0
025Z	4345	2191455	01	3	147.5	135.8	8.7
025Z	4345	2191455	01	4	144.7	130.8	10.6
03QG	4425	2194825	IA01	1	122.5	119.6	2.4
03QG	4425	2194825	IA01	2	126.5	121.4	4.2
03QG	4425	2194825	IA01	3	137.3	129.8	5.8
03QG	4425	2194825	IA01	4	144.2	134.6	7.2
03QG	4425	2194825	IA01	5	142.5	130.5	9.2
03QG	4425	2194825	IA01	6	138.8	126.1	10.0
01TH	4523	2209171	01	1	128.1	123.9	3.4
01TH	4523	2209171	01	2	134.9	129.0	4.6
01TH	4523	2209171	01	3	139.9	132.1	5.9
01TH	4523	2209171	01	4	144.8	135.7	6.7
044U	4683	2203766	01	1	127.7	124.3	2.8
044U	4683	2203766	01	2	138.0	132.7	4.0
044U	4683	2203766	01	3	143.9	135.7	6.0
044U	4683	2203766	01	4	142.1	131.7	7.9
0454	4801	2201692	IA01	1	133.6	128.8	3.7
0454	4801	2201692	IA01	2	141.0	133.6	5.5
0454	4801	2201692	IA01	3	144.6	135.0	7.1
0454	4801	2201692	IA01	4	141.2	130.4	8.2
028T	4895	2205894	01	1	128.3	123.8	3.6

Main PCN	Contract ID	Sample ID	Test #	Seq_Nbr	Wet Density (pcf)	Dry Density (pcf)	Moisture Content (%)
028T	4895	2205894	01	2	138.3	131.2	5.4
028T	4895	2205894	01	3	143.5	134.6	6.6
028T	4895	2205894	01	4	143.2	131.7	8.8
03B0	4900	2215221	01	1	130.1	126.8	2.6
03B0	4900	2215221	01	2	134.2	128.3	4.6
03B0	4900	2215221	01	3	141.8	133.4	6.3
03B0	4900	2215221	01	4	146.3	135.6	7.9
03B0	4900	2215221	01	5	143.3	130.8	9.6
00KB	4913	2222395	01	1	134.1	127.2	5.4
00KB	4913	2222395	01	2	138.3	130.1	6.3
00KB	4913	2222395	01	3	146.9	135.5	8.4
00KB	4913	2222395	01	4	144.9	131.7	10.0
0511	4938	2212386	01	1	140.9	131.9	6.8
0511	4938	2212386	01	2	143.1	133.7	7.1
0511	4938	2212386	01	3	146.1	135.4	7.9
0511	4938	2212386	01	4	143.3	130.0	10.2
037U	5502	2226559	01	1	132.3	127.5	3.7
037U	5502	2226559	01	2	141.9	133.6	6.2
037U	5502	2226559	01	3	145.6	135.5	7.5
037U	5502	2226559	01	4	143.6	131.4	9.3

Table 30: DOT-40 points used for compaction curves with a maximum dry unit weight between 136 pcf to 138 pcf.

Main PCN	Contract ID	Sample ID	Test #	Seq_Nbr	Wet Density (pcf)	Dry Density (pcf)	Moisture Content (%)
1177	944	1004625	Field 01	1	125.4	121.8	3.0
1177	944	1004625	Field 01	2	134.4	127.7	5.2
1177	944	1004625	Field 01	3	144.5	135.2	6.8
1177	944	1004625	Field 01	4	144.0	132.0	9.0
5625	1032	1027874	1	1	134.4	129.5	3.8
5625	1032	1027874	1	2	141.7	134.1	5.7
5625	1032	1027874	1	3	146.1	136.7	6.9
5625	1032	1027874	1	4	147.5	136.1	8.3
5625	1032	1027874	1	5	145.5	133.5	9.0
3913	1093	1030404	01	1	131.1	128.3	2.2
3913	1093	1030404	01	2	141.1	135.2	4.3
3913	1093	1030404	01	3	144.3	136.7	5.6
3913	1093	1030404	01	4	142.2	133.9	6.1
5853	1129	1026363	01	1	130.5	126.0	3.6
5853	1129	1026363	01	2	135.6	129.2	4.9
5853	1129	1026363	01	3	143.7	135.0	6.5
5853	1129	1026363	01	4	143.2	131.2	9.1
5956	1146	1042452	03	1	133.8	128.5	4.1
5956	1146	1042452	03	2	142.2	134.8	5.5
5956	1146	1042452	03	3	146.5	136.5	7.4
5956	1146	1042452	03	4	145.4	132.8	9.5
377N	1293	1039245	01	1	132.0	126.8	4.1
377N	1293	1039245	01	2	140.6	132.7	6.0
377N	1293	1039245	01	3	146.6	136.2	7.7
377N	1293	1039245	01	4	145.2	132.2	9.8
4528	1645	1291920	01	1	127.6	123.8	3.0
4528	1645	1291920	01	2	136.1	129.6	5.0
4528	1645	1291920	01	3	146.5	136.9	7.0
4528	1645	1291920	01	4	145.4	133.8	8.7
6346	1668	1314477	01	1	129.5	124.4	4.1
6346	1668	1314477	01	2	137.1	129.4	5.9
6346	1668	1314477	01	3	143.2	134.1	6.8
6346	1668	1314477	01	4	142.0	130.7	8.7
5999	1674	1271152	1	1	132.8	128.2	3.6
5999	1674	1271152	1	2	139.8	133.1	5.0
5999	1674	1271152	1	3	146.4	136.9	7.0
5999	1674	1271152	1	4	144.5	133.6	8.2

Main PCN	Contract ID	Sample ID	Test #	Seq_Nbr	Wet Density (pcf)	Dry Density (pcf)	Moisture Content (%)
5663	1826	1352940	01	1	135.5	129.7	4.5
5663	1826	1352940	01	2	139.5	131.9	5.8
5663	1826	1352940	01	3	147.5	137.1	7.5
5663	1826	1352940	01	4	147.1	135.5	8.6
5863	1864	1429556	01	1	138.0	132.4	4.2
5863	1864	1429556	01	2	145.2	136.7	6.2
5863	1864	1429556	01	3	147.6	136.9	7.8
5863	1864	1429556	01	4	145.5	133.1	9.3
3139	1944	1466032	001	1	130.9	129.0	1.5
3139	1944	1466032	001	2	142.6	135.3	5.4
3139	1944	1466032	001	3	146.3	136.1	7.5
3139	1944	1466032	001	4	147.5	136.4	8.2
001A	1971	1420547	01	1	130.0	127.0	2.4
001A	1971	1420547	01	2	136.0	131.0	3.8
001A	1971	1420547	01	3	141.8	134.8	5.2
001A	1971	1420547	01	4	144.0	133.9	7.6
3783	2110	1461585	Field01	1	134.2	127.4	5.3
3783	2110	1461585	Field01	2	144.2	135.3	6.6
3783	2110	1461585	Field01	3	145.7	133.7	9.0
3783	2110	1461585	Field01	4	142.6	128.6	10.9
5342	2438	1479731	Field01	1	124.9	120.8	3.4
5342	2438	1479731	Field01	2	133.9	126.9	5.6
5342	2438	1479731	Field01	3	144.1	134.6	7.1
5342	2438	1479731	Field01	4	144.1	131.4	9.6
6185	2636	2071926	Field # 1	1	132.5	128.2	3.3
6185	2636	2071926	Field # 1	2	139.3	132.5	5.1
6185	2636	2071926	Field # 1	3	145.9	136.3	7.1
6185	2636	2071926	Field # 1	4	142.9	130.0	9.9
01PT	2667	2070057	01	1	124.2	120.5	3.1
01PT	2667	2070057	01	2	135.0	128.8	4.8
01PT	2667	2070057	01	3	144.7	135.5	6.8
01PT	2667	2070057	01	4	143.5	131.0	9.6
020G	3067	2092282	Field01	1	132.9	129.3	2.8
020G	3067	2092282	Field01	2	142.8	135.9	5.1
020G	3067	2092282	Field01	3	146.8	137.0	7.1
020G	3067	2092282	Field01	4	145.3	132.8	9.4
020G	3067	2103425	Field02	1	131.0	126.4	3.7
020G	3067	2103425	Field02	2	141.4	133.9	5.6
020G	3067	2103425	Field02	3	146.6	136.8	7.2

Main PCN	Contract ID	Sample ID	Test #	Seq_Nbr	Wet Density (pcf)	Dry Density (pcf)	Moisture Content (%)
020G	3067	2103425	Field02	4	146.2	131.9	10.9
02FM	3286	2094453	01	1	133.0	127.2	4.6
02FM	3286	2094453	01	2	143.6	134.7	6.6
02FM	3286	2094453	01	3	147.4	136.7	7.9
02FM	3286	2094453	01	4	144.4	130.9	10.3
02FS	3288	2099484	01	1	121.3	120.1	1.0
02FS	3288	2099484	01	2	124.8	122.8	1.6
02FS	3288	2099484	01	3	131.7	128.4	2.5
02FS	3288	2099484	01	4	138.2	133.2	3.7
02FS	3288	2099484	01	5	143.6	136.6	5.1
02FS	3288	2099484	01	6	139.0	130.3	6.7
020J	3401	2100956	01	1	133.5	128.1	4.2
020J	3401	2100956	01	2	144.3	136.4	5.8
020J	3401	2100956	01	3	144.0	134.4	7.2
020J	3401	2100956	01	4	145.4	134.5	8.1
020J	3401	2100956	01	5	144.7	131.9	9.7
02ND	3485	2101797	01	1	136.5	131.1	4.1
02ND	3485	2101797	01	2	143.7	135.5	6.1
02ND	3485	2101797	01	3	146.4	135.5	8.0
02ND	3485	2101797	01	4	143.7	136.1	5.5
02NK	3489	2103794	01	1	136.4	130.5	4.5
02NK	3489	2103794	01	2	145.3	136.3	6.6
02NK	3489	2103794	01	3	146.1	134.8	8.3
02NK	3489	2103794	01	4	144.5	131.7	9.7
01DE	3552	2123815	01	1	132.2	128.6	2.8
01DE	3552	2123815	01	2	137.4	131.6	4.4
01DE	3552	2123815	01	3	144.2	136.7	5.5
01DE	3552	2123815	01	4	143.9	132.6	8.6
01DE	3552	2123815	01	5	124.2	122.5	1.4
6954	3609	2139054	IA02	1	133.6	126.1	5.9
6954	3609	2139054	IA02	2	138.4	129.6	6.8
6954	3609	2139054	IA02	3	137.1	126.1	8.7
6954	3609	2139054	IA02	4	137.4	129.6	6.0
01D9	3638	2112583	02	1	135.0	128.8	4.8
01D9	3638	2112583	02	2	145.1	135.9	6.8
01D9	3638	2112583	02	3	146.5	136.3	7.4
01D9	3638	2112583	02	4	144.9	132.7	9.2
01FP	3707	2135201	01	1	142.0	136.2	4.3
01FP	3707	2135201	01	2	143.8	135.9	5.8

Main PCN	Contract ID	Sample ID	Test #	Seq_Nbr	Wet Density (pcf)	Dry Density (pcf)	Moisture Content (%)
01FP	3707	2135201	01	3	144.0	135.1	6.6
01FP	3707	2135201	01	4	134.6	130.6	3.1
03BJ	3767	2122447	01	1	137.7	131.8	4.5
03BJ	3767	2122447	01	2	146.4	137.3	6.6
03BJ	3767	2122447	01	3	146.9	135.1	8.7
03BJ	3767	2122447	01	4	144.8	131.1	10.4
03BR	3768	2126793	01	1	132.1	127.3	3.8
03BR	3768	2126793	01	2	138.3	130.7	5.8
03BR	3768	2126793	01	3	145.7	135.8	7.3
03BR	3768	2126793	01	4	141.9	130.0	9.2
00KR	3875	2167844	01	1	136.3	129.3	5.5
00KR	3875	2167844	01	2	142.7	133.4	7.0
00KR	3875	2167844	01	3	147.3	136.8	7.7
00KR	3875	2167844	01	4	144.6	132.7	8.9
03D3	3913	2154925	01	1	132.0	125.9	4.9
03D3	3913	2154925	01	2	138.7	131.0	5.8
03D3	3913	2154925	01	3	146.8	136.4	7.6
03D3	3913	2154925	01	4	145.3	132.4	9.7
03HK	3938	2158507	02	1	141.2	133.7	5.6
03HK	3938	2158507	02	2	146.4	137.1	6.7
03HK	3938	2158507	02	3	147.3	137.3	7.3
03HK	3938	2158507	02	4	142.5	129.4	10.1
4437	4077	2158898	01	1	134.1	127.4	5.2
4437	4077	2158898	01	2	144.5	135.6	6.6
4437	4077	2158898	01	3	145.9	134.8	8.3
4437	4077	2158898	01	4	144.2	129.8	11.1
035V	4190	2159900	01	1	134.1	128.8	4.1
035V	4190	2159900	01	2	143.9	136.1	5.7
035V	4190	2159900	01	3	145.9	135.6	7.6
035V	4190	2159900	01	4	142.9	130.8	9.3
025Z	4345	2191455	01	1	132.9	126.5	5.0
025Z	4345	2191455	01	2	143.3	134.0	7.0
025Z	4345	2191455	01	3	147.5	135.8	8.7
025Z	4345	2191455	01	4	144.7	130.8	10.6
03QG	4425	2194825	IA01	1	122.5	119.6	2.4
03QG	4425	2194825	IA01	2	126.5	121.4	4.2
03QG	4425	2194825	IA01	3	137.3	129.8	5.8
03QG	4425	2194825	IA01	4	144.2	134.6	7.2
03QG	4425	2194825	IA01	5	142.5	130.5	9.2

Main PCN	Contract ID	Sample ID	Test #	Seq_Nbr	Wet Density (pcf)	Dry Density (pcf)	Moisture Content (%)
03QG	4425	2194825	IA01	6	138.8	126.1	10.0
01TH	4523	2209171	01	1	128.1	123.9	3.4
01TH	4523	2209171	01	2	134.9	129.0	4.6
01TH	4523	2209171	01	3	139.9	132.1	5.9
01TH	4523	2209171	01	4	144.8	135.7	6.7
04D0	4548	2190357	IA02	1	136.5	131.0	4.2
04D0	4548	2190357	IA02	2	141.7	134.9	5.1
04D0	4548	2190357	IA02	3	144.0	134.3	7.2
04D0	4548	2190357	IA02	4	141.8	130.9	8.4
6161	4563	2204663	01	1	131.9	126.6	4.2
6161	4563	2204663	01	2	140.4	132.3	6.2
6161	4563	2204663	01	3	145.6	135.7	7.3
6161	4563	2204663	01	4	144.7	132.3	9.3
038D	4899	2206544	01	1	128.8	125.3	2.8
038D	4899	2206544	01	2	135.6	130.3	4.0
038D	4899	2206544	01	3	144.3	136.1	6.0
038D	4899	2206544	01	4	145.5	135.3	7.5
051L	5011	2214781	01	1	131.6	126.2	4.3
051L	5011	2214781	01	2	139.9	132.2	5.8
051L	5011	2214781	01	3	145.9	136.1	7.2
051L	5011	2214781	01	4	144.8	132.4	9.3
04AE	6034	2227768	01	1	128.8	126.6	1.8
04AE	6034	2227768	01	2	133.2	129.0	3.2
04AE	6034	2227768	01	3	141.6	134.7	5.1
04AE	6034	2227768	01	4	145.2	135.8	6.9
04AE	6034	2227768	01	5	143.7	132.7	8.3
5862	1422	1081029	01-info	1	138.4	132.1	4.7
5862	1422	1081029	01	2	146.1	136.4	7.1
5862	1422	1081029	01-info	3	148.5	137.6	7.9
5862	1422	1081029	01	4	143.3	130.6	9.7
6229	1537	1273567	03	1	130.4	125.9	3.5
6229	1537	1273567	03	2	140.9	133.3	5.7
6229	1537	1273567	03	3	148.8	137.8	8.0
6229	1537	1273567	03	4	145.8	133.5	9.3
6229	1537	1278018	02	1	132.9	127.6	4.1
6229	1537	1278018	02	2	144.0	136.3	5.6
6229	1537	1278018	02	3	147.3	136.8	7.7
6229	1537	1278018	02	4	146.2	133.7	9.4
6146	1933	1403727	01	1	129.2	126.8	2.0

Main PCN	Contract ID	Sample ID	Test #	Seq_Nbr	Wet Density (pcf)	Dry Density (pcf)	Moisture Content (%)
6146	1933	1403727	01	2	135.8	131.3	3.4
6146	1933	1403727	01	3	142.9	136.3	4.9
6146	1933	1403727	01	4	145.5	136.3	6.7
00UY	2079	1414996	01	1	132.4	128.9	2.7
00UY	2079	1414996	01	2	139.9	133.9	4.5
00UY	2079	1414996	01	3	145.9	137.4	6.1
00UY	2079	1414996	01	4	147.5	137.5	7.2
6922	2525	1480056	02	1	135.8	129.5	4.8
6922	2525	1480056	02	2	142.1	134.0	6.0
6922	2525	1480056	02	3	146.2	134.9	8.4
6922	2525	1480056	02	4	141.0	128.4	9.9
01AK	2553	1475202	IA01	1	135.2	127.6	5.9
01AK	2553	1475202	IA01	2	138.3	129.4	6.9
01AK	2553	1475202	IA01	3	145.2	135.2	7.4
01AK	2553	1475202	IA01	4	148.1	136.1	8.9
01AK	2553	1475202	IA01	5	146.4	131.6	11.3
I1ZS	3494	2102031	01	1	135.6	131.0	3.5
I1ZS	3494	2102031	01	2	142.2	135.8	4.7
I1ZS	3494	2102031	01	3	145.0	136.9	5.9
I1ZS	3494	2102031	01	4	147.5	137.5	7.3
02Q5	3770	2137589	IA01	1	134.0	129.7	3.4
02Q5	3770	2137589	IA01	2	144.0	137.1	5.0
02Q5	3770	2137589	IA01	3	146.1	137.8	6.0
02Q5	3770	2137589	IA01	4	144.9	134.8	7.5
023C	3890	2142555	01	1	139.9	133.1	5.1
023C	3890	2142555	01	2	146.1	136.8	6.8
023C	3890	2142555	01	3	143.1	131.3	9.0
023C	3890	2142555	01	4	141.7	128.1	10.6
023C	3890	2154348	02	1	138.0	132.4	4.2
023C	3890	2154348	02	2	145.2	136.9	6.1
023C	3890	2154348	02	3	147.1	135.6	8.4
023C	3890	2154348	02	4	144.7	131.3	10.2
02CY	3978	2172044	01	1	131.5	129.8	1.4
02CY	3978	2172044	01	2	134.7	130.8	3.0
02CY	3978	2172044	01	3	140.3	133.6	5.0
02CY	3978	2172044	01	4	146.6	137.8	6.4
02CY	3978	2172044	01	5	145.4	133.4	9.0
0377	4085	2162161	01	1	129.7	124.9	3.8
0377	4085	2162161	01	2	133.2	126.9	5.0

Main PCN	Contract ID	Sample ID	Test #	Seq_Nbr	Wet Density (pcf)	Dry Density (pcf)	Moisture Content (%)
0377	4085	2162161	01	3	138.9	130.9	6.1
0377	4085	2162161	01	4	144.8	131.0	10.5
I2Y7	4474	2182106	01	1	138.7	133.2	4.1
I2Y7	4474	2182106	01	2	146.4	138.0	6.1
I2Y7	4474	2182106	01	3	146.1	136.3	7.2
I2Y7	4474	2182106	01	4	130.9	127.3	2.9
05M5	6031	2223821	01	1	128.3	125.3	2.3
05M5	6031	2223821	01	2	134.5	129.5	3.8
05M5	6031	2223821	01	3	142.0	135.1	5.1
05M5	6031	2223821	01	4	145.1	134.9	7.6
5956	1146	1040580	02	1	132.0	125.7	5.0
5956	1146	1040580	02	2	141.0	132.9	6.1
5956	1146	1040580	02	3	143.3	134.4	6.6
5956	1146	1040580	02	4	148.6	137.5	8.1
5956	1146	1040580	02	5	147.7	135.8	8.7

Table 31: DOT-40 points used for compaction curves with a maximum dry unit weight between 138 pcf to 140 pcf.

Main PCN	Contract ID	Sample ID	Test #	Seq_Nbr	Wet Density (pcf)	Dry Density (pcf)	Moisture Content (%)
6223	1161	1028708	01	1	132.7	129.1	2.8
6223	1161	1028708	01	2	138.8	133.7	3.8
6223	1161	1028708	01	3	143.5	137.2	4.6
6223	1161	1028708	01	4	146.8	139.1	5.6
6223	1161	1028708	01	5	144.5	136.3	6.0
4876	1251	1080909	002	1	135.0	130.0	3.9
4876	1251	1080909	002	2	141.8	135.5	4.7
4876	1251	1080909	002	3	148.6	139.5	6.6
4876	1251	1080909	002	4	150.0	138.6	8.2
4876	1251	1080909	002	5	148.6	137.2	8.3
4998	1439	1086460	01	1	137.7	132.4	4.0
4998	1439	1086460	01	2	147.2	138.9	6.0
4998	1439	1086460	01	3	147.7	137.1	7.7
4998	1439	1086460	01	4	144.5	132.1	9.4
6229	1537	1127463	01	1	137.2	132.1	3.8
6229	1537	1127463	01	2	142.9	136.5	4.7
6229	1537	1127463	01	3	146.2	136.9	6.8
6229	1537	1127463	01	4	146.0	133.4	9.4
5933	1539	1274800	02	1	141.4	135.0	4.7
5933	1539	1274800	02	2	142.9	135.2	5.8
5933	1539	1274800	02	3	148.3	138.0	7.5
5933	1539	1274800	02	4	145.6	133.4	9.2
5863	1864	1448774	02	1	138.0	132.6	4.1
5863	1864	1448774	02	2	146.3	138.2	5.9
5863	1864	1448774	02	3	147.5	136.5	8.0
5863	1864	1448774	02	4	145.2	132.9	9.2
3732	1889	1422724	01	1	137.7	132.0	4.3
3732	1889	1422724	01	2	144.6	136.5	6.0
3732	1889	1422724	01	3	150.1	139.3	7.8
3732	1889	1422724	01	4	145.3	132.4	9.7
6556	2181	1804140	1	1	138.9	133.3	4.2
6556	2181	1804140	1	2	147.8	138.9	6.4
6556	2181	1804140	1	3	149.0	138.5	7.6
6556	2181	1804140	1	4	129.7	126.1	2.8
6287	2221	1410730	21125	1	141.0	134.3	5.0
6287	2221	1410730	21125	2	147.6	138.6	6.5
6287	2221	1410730	21125	3	145.6	135.1	7.8

Main PCN	Contract ID	Sample ID	Test #	Seq_Nbr	Wet Density (pcf)	Dry Density (pcf)	Moisture Content (%)
6287	2221	1410730	21125	4	141.1	128.7	9.6
H100	2336	2204583	01	1	122.7	120.4	1.9
H100	2336	2204583	01	2	139.3	134.0	4.0
H100	2336	2204583	01	3	147.2	139.1	5.9
H100	2336	2204583	01	4	148.8	137.2	8.5
01QN	2920	2084790	01	1	139.6	134.1	4.1
01QN	2920	2084790	01	2	146.9	138.0	6.4
01QN	2920	2084790	01	3	145.0	133.9	8.3
01QN	2920	2084790	01	4	144.8	132.0	9.7
02KH	3139	2102524	01	1	133.5	131.4	1.6
02KH	3139	2102524	01	2	137.6	133.4	3.1
02KH	3139	2102524	01	3	145.1	138.1	5.1
02KH	3139	2102524	01	4	146.0	136.0	7.4
02KH	3139	2116953	02	1	136.6	133.0	2.7
02KH	3139	2116953	02	2	141.9	136.4	4.0
02KH	3139	2116953	02	3	146.2	138.9	5.3
02KH	3139	2116953	02	4	146.9	137.6	6.8
02G1	3284	2087317	01	1	133.9	129.6	3.4
02G1	3284	2087317	01	2	143.2	136.8	4.7
02G1	3284	2087317	01	3	148.6	139.7	6.3
02G1	3284	2087317	01	4	149.0	139.2	7.0
025B	3338	2116328	IA01	1	127.1	122.5	3.7
025B	3338	2116328	IA01	2	136.9	129.8	5.5
025B	3338	2116328	IA01	3	145.9	136.9	6.6
025B	3338	2116328	IA01	4	145.1	133.5	8.7
020J	3401	2104182	01	1	132.2	129.4	2.1
020J	3401	2104182	01	2	140.7	135.6	3.7
020J	3401	2104182	01	3	146.0	137.8	6.0
020J	3401	2104182	01	4	144.2	134.3	7.3
00GR	3504	2110045	02	1	139.7	134.3	4.0
00GR	3504	2110045	02	2	146.9	138.4	6.1
00GR	3504	2110045	02	3	145.7	135.2	7.8
00GR	3504	2110045	02	4	143.5	131.2	9.4
03Q4	4068	2151077	02	1	124.4	121.6	2.3
03Q4	4068	2151077	02	2	133.8	129.3	3.5
03Q4	4068	2151077	02	3	141.4	135.5	4.4
03Q4	4068	2151077	02	4	145.1	137.0	6.0
02Q1	4076	2173813	02	1	128.9	121.7	5.9
02Q1	4076	2173813	02	2	136.6	126.6	7.9

Main PCN	Contract ID	Sample ID	Test #	Seq_Nbr	Wet Density (pcf)	Dry Density (pcf)	Moisture Content (%)
02Q1	4076	2173813	02	3	141.8	129.1	9.8
02Q1	4076	2173813	02	4	140.2	127.7	9.8
0357	4180	2166515	02	1	142.0	135.9	4.5
0357	4180	2166515	02	2	144.9	136.8	5.9
0357	4180	2166515	02	3	148.8	138.9	7.1
0357	4180	2166515	02	4	148.3	137.2	8.1
0357	4180	2166515	02	5	136.2	131.3	3.7
02SE	4219	2166562	01	1	129.9	126.6	2.6
02SE	4219	2166562	01	2	137.6	132.5	3.9
02SE	4219	2166562	01	3	144.1	137.1	5.1
02SE	4219	2166562	01	4	148.1	138.8	6.7
049J	4324	2172989	01	1	135.2	130.1	3.9
049J	4324	2172989	01	2	145.1	137.7	5.4
049J	4324	2172989	01	3	148.3	139.1	6.6
049J	4324	2172989	01	4	146.7	136.5	7.4
02AB	4514	2197078	02	1	134.0	129.6	3.4
02AB	4514	2197078	02	2	142.8	136.4	4.7
02AB	4514	2197078	02	3	146.9	138.1	6.4
02AB	4514	2197078	02	4	144.8	134.1	8.0
3465	4586	2204159	01	1	131.6	128.4	2.5
3465	4586	2204159	01	2	136.8	131.3	4.2
3465	4586	2204159	01	3	145.3	137.3	5.8
3465	4586	2204159	01	4	147.7	136.3	8.4
6925	4588	2203731	01	1	134.1	130.4	2.9
6925	4588	2203731	01	2	139.1	137.1	1.4
6925	4588	2203731	01	3	146.5	139.1	5.3
6925	4588	2203731	01	4	146.1	136.8	6.8
04DA	5050	2224917	02	1	128.7	126.5	1.7
04DA	5050	2224917	02	2	134.8	131.0	2.9
04DA	5050	2224917	02	3	143.9	137.8	4.4
04DA	5050	2224917	02	4	146.0	137.8	5.9
020U	5120	2224562	01	1	125.5	123.5	1.6
020U	5120	2224562	01	2	129.3	125.6	3.0
020U	5120	2224562	01	3	136.3	130.6	4.4
020U	5120	2224562	01	4	145.5	136.9	6.2
020U	5120	2224562	01	5	150.6	139.0	8.4
03C2	5178	2226043	02	1	126.0	123.2	2.3
03C2	5178	2226043	02	2	135.3	130.8	3.4
03C2	5178	2226043	02	3	143.1	136.8	4.6

Main PCN	Contract ID	Sample ID	Test #	Seq_Nbr	Wet Density (pcf)	Dry Density (pcf)	Moisture Content (%)
03C2	5178	2226043	02	4	148.3	139.6	6.2
03C2	5178	2226043	02	5	148.8	136.5	9.0

Table 32: DOT-40 points used for compaction curves with a maximum dry unit weight between 140 pcf to 142 pcf.

Main PCN	Contract ID	Sample ID	Test #	Seq_Nbr	Wet Density (pcf)	Dry Density (pcf)	Moisture Content (%)
3864	1170	1092095	01	1	125.1	123.3	1.4
3864	1170	1092095	01	2	131.2	128.1	2.4
3864	1170	1092095	01	3	139.2	134.5	3.5
3864	1170	1092095	01	4	146.5	140.2	4.5
3864	1170	1092095	01	5	145.7	137.2	6.2
5658	1450	1261746	1	1	121.8	119.6	1.8
5658	1450	1261746	02	2	131.6	127.6	3.1
5658	1450	1261746	1	3	141.5	135.9	4.1
5658	1450	1261746	02	4	148.3	139.8	6.0
107N	1462	1083366	01	1	130.4	129.1	1.1
107N	1462	1083366	01	2	133.1	129.8	2.5
107N	1462	1083366	01	3	142.6	137.3	3.8
107N	1462	1083366	01	4	148.9	140.4	6.1
107N	1462	1083366	01	5	148.4	137.3	8.1
5586	2103	1467520	02	1	134.6	131.4	2.5
5586	2103	1467520	02	2	144.7	139.4	3.8
5586	2103	1467520	02	3	148.8	141.3	5.3
5586	2103	1467520	02	4	149.0	139.6	6.7
00E4	2182	1430197	02	1	130.5	128.1	1.8
00E4	2182	1430197	02	2	138.0	133.7	3.2
00E4	2182	1430197	02	3	146.7	139.8	5.0
00E4	2182	1430197	02	4	147.3	138.7	6.2
00DV	2252	1414276	01	1	128.0	125.2	2.3
00DV	2252	1414276	01	2	136.0	131.5	3.4
00DV	2252	1414276	01	3	147.7	140.1	5.4
00DV	2252	1414276	01	4	148.9	140.2	6.2
6292	2264	2080343	01	1	143.6	137.4	4.5
6292	2264	2080343	01	2	148.4	140.2	5.8
6292	2264	2080343	01	3	147.2	137.5	7.0
6292	2264	2080343	01	4	145.7	135.0	7.9
6436	2717	2079075	01	1	129.8	125.3	3.6
6436	2717	2079075	01	2	139.3	132.7	5.0
6436	2717	2079075	01	3	145.5	134.3	8.3
6436	2717	2079075	01	4	143.8	132.5	8.5
00RE	3296	2098574	01	1	129.8	125.7	3.2
00RE	3296	2098574	01	2	135.7	129.5	4.8
00RE	3296	2098574	01	3	145.5	137.2	6.1

Main PCN	Contract ID	Sample ID	Test #	Seq_Nbr	Wet Density (pcf)	Dry Density (pcf)	Moisture Content (%)
00RE	3296	2098574	01	4	145.2	133.9	8.5
00X9	3607	2133080	01	1	131.4	129.2	1.7
00X9	3607	2133080	01	2	136.8	132.5	3.2
00X9	3607	2133080	01	3	145.0	138.6	4.6
00X9	3607	2133080	01	4	148.6	140.0	6.1
I1ZZ	3610	2103548	01	1	128.4	125.4	2.4
I1ZZ	3610	2103548	01	2	140.4	135.4	3.7
I1ZZ	3610	2103548	01	3	146.6	139.5	5.1
I1ZZ	3610	2103548	01	4	149.5	139.9	6.9
H021	3634	2126475	01	1	129.2	126.8	1.8
H021	3634	2126475	01	2	138.8	134.6	3.2
H021	3634	2126475	01	3	147.6	140.7	4.8
H021	3634	2126475	01	4	149.2	140.8	5.9
02ZN	3663	2126396	01	1	129.2	126.8	1.8
02ZN	3663	2126396	01	2	138.8	134.6	3.2
02ZN	3663	2126396	01	3	147.6	140.7	4.8
02ZN	3663	2126396	01	4	149.2	140.8	5.9
00L5	3778	2145514	IA01	1	130.4	125.6	3.9
00L5	3778	2145514	IA01	2	141.2	133.8	5.5
00L5	3778	2145514	IA01	3	148.8	139.5	6.7
00L5	3778	2145514	IA01	4	144.5	131.8	9.7
00QC	3832	2151550	01	1	136.9	132.7	3.2
00QC	3832	2151550	01	2	143.8	137.5	4.5
00QC	3832	2151550	01	3	148.8	141.0	5.5
00QC	3832	2151550	01	4	148.2	140.0	5.9
023D	3931	2160089	01	1	135.2	132.2	2.2
023D	3931	2160089	01	2	142.5	137.1	4.0
023D	3931	2160089	01	3	148.5	140.7	5.6
023D	3931	2160089	01	4	147.3	136.9	7.6
03HK	3938	2152515	01	1	133.8	128.8	3.9
03HK	3938	2152515	01	2	145.1	137.7	5.4
03HK	3938	2152515	01	3	149.3	140.5	6.3
03HK	3938	2152515	01	4	145.3	135.0	7.6
00D0	3980	2157953	01	1	131.9	128.9	2.3
00D0	3980	2157953	01	2	143.3	137.3	4.4
00D0	3980	2157953	01	3	149.9	141.8	5.7
00D0	3980	2157953	01	4	148.3	139.3	6.5
022E	4074	2194424	01	1	128.7	126.9	1.4
022E	4074	2194424	01	2	135.3	131.6	2.8

Main PCN	Contract ID	Sample ID	Test #	Seq_Nbr	Wet Density (pcf)	Dry Density (pcf)	Moisture Content (%)
022E	4074	2194424	01	3	141.9	136.4	4.0
022E	4074	2194424	01	4	150.0	141.5	6.0
00YX	4173	2184259	01	1	130.9	127.8	2.4
00YX	4173	2184259	01	2	144.5	138.8	4.2
00YX	4173	2184259	01	3	147.7	139.6	5.8
00YX	4173	2184259	01	4	147.2	135.3	8.8
0297	4233	2178531	IA01	1	131.6	128.3	2.6
0297	4233	2178531	IA01	2	137.7	132.2	4.2
0297	4233	2178531	IA01	3	148.2	140.0	5.9
0297	4233	2178531	IA01	4	147.3	136.6	7.8
I2TX	4397	2183565	IA02	1	145.3	138.2	5.1
I2TX	4397	2183565	IA02	2	146.6	138.0	6.2
I2TX	4397	2183565	IA02	3	145.6	135.9	7.1
I2TX	4397	2183565	IA02	4	144.8	135.9	6.5
028L	4439	2189750	01	1	128.9	126.0	2.3
028L	4439	2189750	01	2	137.2	131.7	4.2
028L	4439	2189750	01	3	141.9	135.0	5.1
028L	4439	2189750	01	4	151.3	141.9	6.6
1162	4992	2222983	01	1	127.7	125.7	1.6
1162	4992	2222983	01	2	136.5	132.4	3.1
1162	4992	2222983	01	3	145.5	139.0	4.6
1162	4992	2222983	01	4	149.1	139.2	7.1
04QE	4719	2203697	01	1	129.7	127.7	1.6
04QE	4719	2203697	01	2	131.1	127.5	2.8
04QE	4719	2203697	01	3	142.9	136.9	4.4
04QE	4719	2203697	01	4	150.0	140.3	6.9
04QE	4719	2203697	01	5	149.5	138.4	8.0

Table 33: DOT-40 points used for compaction curves with a maximum dry unit weight between 142 pcf to 144 pcf.

Main PCN	Contract ID	Sample ID	Test #	Seq_Nbr	Wet Density (pcf)	Dry Density (pcf)	Moisture Content (%)
01BP	3075	2087523	01	1	138.2	133.4	3.6
01BP	3075	2087523	01	2	146.3	140.0	4.5
01BP	3075	2087523	01	3	150.1	142.3	5.5
01BP	3075	2087523	01	4	150.3	141.3	6.4
H079	4116	2158306	01	1	134.6	131.3	2.5
H079	4116	2158306	01	2	144.2	138.6	4.1
H079	4116	2158306	01	3	149.7	142.3	5.2
H079	4116	2158306	01	4	149.7	141.7	5.7
02S8	4907	2207599	01	1	131.2	128.6	2.0
02S8	4907	2207599	01	2	136.0	131.3	3.6
02S8	4907	2207599	01	3	147.5	139.6	5.6
02S8	4907	2207599	01	4	150.1	138.5	8.4
04GR	5512	2227605	01	1	131.2	128.6	2.0
04GR	5512	2227605	01	2	136.0	131.3	3.6
04GR	5512	2227605	01	3	147.5	139.6	5.6
04GR	5512	2227605	01	4	150.1	138.5	8.4
3864	1170	1087625	01	1	129.0	127.5	1.2
3864	1170	1087625	01	2	133.1	130.4	2.1
3864	1170	1087625	01	3	144.1	140.4	2.7
3864	1170	1087625	01	4	148.7	142.6	4.3
3864	1170	1087625	01	5	145.9	137.2	6.3
3151	1438	1256497	03	1	140.3	134.3	4.4
3151	1438	1256497	03	2	144.8	136.7	5.9
3151	1438	1256497	03	3	143.1	133.5	7.2
3151	1438	1256497	03	4	142.8	136.6	4.5
6688	1653	1261743	01	1	132.8	129.9	2.2
6688	1653	1261743	01	2	140.5	135.6	3.6
6688	1653	1261743	01	3	148.2	141.5	4.8
6688	1653	1261743	01	4	148.0	138.3	7.0
4259	1694	1294082	01	1	132.0	129.4	2.0
4259	1694	1294082	01	2	142.7	137.6	3.7
4259	1694	1294082	01	3	149.6	142.2	5.2
4259	1694	1294082	01	4	129.1	127.3	1.4
4259	1694	1294082	01	5	150.1	139.8	7.4
1939	2167	1414190	01	1	129.3	127.1	1.7
1939	2167	1414190	01	2	138.8	134.3	3.3
1939	2167	1414190	01	3	148.1	141.6	4.6

Main PCN	Contract ID	Sample ID	Test #	Seq_Nbr	Wet Density (pcf)	Dry Density (pcf)	Moisture Content (%)
1939	2167	1414190	01	4	150.8	142.2	6.0
01PQ	2626	2067336	01	1	132.2	130.2	1.5
01PQ	2626	2067336	01	2	138.1	134.1	3.0
01PQ	2626	2067336	01	3	147.4	141.2	4.4
01PQ	2626	2067336	01	4	149.3	140.1	6.5
01B5	2930	2080354	01	1	126.5	123.8	2.2
01B5	2930	2080354	01	2	140.4	134.5	4.3
01B5	2930	2080354	01	3	148.2	140.1	5.8
01B5	2930	2080354	01	4	149.3	136.2	9.6
02G1	3284	2094340	02	1	131.9	127.9	3.2
02G1	3284	2094340	02	2	143.2	137.4	4.2
02G1	3284	2094340	02	3	150.3	142.4	5.6
02G1	3284	2094340	02	4	149.9	140.0	7.1
01BT	3554	2130660	01	1	137.8	132.9	3.6
01BT	3554	2130660	01	2	149.0	141.8	5.1
01BT	3554	2130660	01	3	150.9	141.4	6.8
01BT	3554	2130660	01	4	126.1	123.0	2.5
0358	4421	2189275	01	1	129.7	127.3	1.9
0358	4421	2189275	01	2	134.5	130.1	3.4
0358	4421	2189275	01	3	146.7	140.1	4.7
0358	4421	2189275	01	4	149.7	141.7	5.7
0358	4421	2189275	01	5	149.1	138.5	7.6
04DA	5050	2224599	01	1	132.9	129.8	2.4
04DA	5050	2224599	01	2	145.6	139.5	4.3
04DA	5050	2224599	01	3	150.5	143.0	5.3
04DA	5050	2224599	01	4	146.9	137.2	7.0

Table 34: OMC and maximum dry unit weight determinations less than 118 pcf.

Maximum Dry Unit Weight (pcf)	OMC (%)
115.4	15.2
117.8	12.5
116.2	12.7

Table 35: OMC and maximum dry unit weight determinations between 118 pcf and 120 pcf.

Maximum Dry Unit Weight (pcf)	OMC (%)
119.8	11.7
119.5	11.6
119.0	12.9
118.2	13.1
118.5	12.4
119.9	11.8
119.5	11.5
119.5	12.1
118.9	12.8
119.5	12.1
119.6	12.1

Table 36: OMC and maximum dry unit weight determinations between 120 pcf and 122 pcf.

Maximum Dry Unit Weight (pcf)	OMC (%)
120.5	10.7
121.2	9.8
120.7	11.6
121.1	11.5
120.0	12.8
120.5	11.2
122.0	11.0
121.6	11.2
120.7	11.6
120.8	12.5
120.4	11.9
120.8	11.6
120.3	12.2
121.8	11.8
120.0	11.7
121.8	11.8
120.0	11.7

Table 37: OMC and maximum dry unit weight determinations between 122 pcf and 124 pcf.

Maximum Dry Unit Weight (pcf)	OMC (%)
122.4	7.1
123.2	10.0
123.8	10.6
124.0	10.7
122.5	12.0
122.8	10.7

Table 38: OMC and maximum dry unit weight determinations between 124 pcf and 126 pcf.

Maximum Dry Unit Weight (pcf)	OMC (%)
124.5	9.1
124.5	10.9
124.7	10.5
124.6	9.8
124.7	9.4
124.9	10.8
124.6	8.6
124.8	7.0
125.6	6.2
125.7	9.0
126.0	13.2
125.9	9.0
125.0	10.9
125.8	9.1
125.5	10.4
125.5	8.1

Table 39: OMC and maximum dry unit weight determinations between 126 pcf and 128 pcf.

Maximum Dry Unit Weight (pcf)	OMC (%)
126.2	6.9
126.6	7.8
126.9	9.9
126.1	11.1
127.0	9.3
126.8	10.7
127.2	11.3
127.1	7.2
126.9	8.2
127.7	10.5
127.8	8.9
127.6	10.5

Table 40: OMC and maximum dry unit weight determinations between 128 pcf and 130 pcf.

Maximum Dry Unit Weight (pcf)	OMC (%)
129.8	9.8
128.3	5.9
129.8	9.8
129.1	9.4
128.5	10.8
128.4	9.4
128.3	9.3
129.2	6.5
129.2	9.3
128.3	9.8
128.5	7.4
128.1	8.3
128.4	6.3
129.7	8.5
128.7	10.0
128.4	8.7
129.0	10.3
130.0	8.6
128.4	11.0
128.4	9.8
129.8	7.7
129.9	9.4
129.9	10.0
128.8	9.2
129.4	9.0
129.8	6.8
129.5	9.6
129.1	10.8
128.6	6.7
128.9	8.9
129.2	8.6
129.3	8.3
128.4	11.0
129.8	8.6
129.3	10.2
128.6	8.4
129.2	10.2
129.0	7.6
129.9	7.0
129.8	9.3

Table 41: OMC and maximum dry unit weight determinations between 130 pcf and 132 pcf.

Maximum Dry Unit Weight (pcf)	OMC (%)
129.8	9.8
128.3	5.9
129.8	9.8
129.1	9.4
128.5	10.8
128.4	9.4
128.3	9.3
129.2	6.5
129.2	9.3
128.3	9.8
128.5	7.4
128.1	8.3
128.4	6.3
129.7	8.5
128.7	10.0
128.4	8.7
129.0	10.3
130.0	8.6
128.4	11.0
128.4	9.8
129.8	7.7
129.9	9.4
129.9	10.0
128.8	9.2
129.4	9.0
129.8	6.8
129.5	9.6
129.1	10.8
128.6	6.7
128.9	8.9
129.2	8.6
129.3	8.3
128.4	11.0
129.8	8.6
129.3	10.2
128.6	8.4
129.2	10.2
129.0	7.6
129.9	7.0
129.8	9.3

Table 42: OMC and maximum dry unit weight determinations between 132 pcf and 134 pcf.

Maximum Dry Unit Weight (pcf)	OMC (%)	Maximum Dry Unit Weight (pcf)	OMC (%)
132.0	7.5	132.9	7.8
132.1	8.4	132.9	8.0
132.1	8.4	133.0	8.2
132.1	8.2	133.1	6.7
132.1	8.8	133.1	7.9
132.2	9.5	133.1	6.9
132.2	7.5	133.1	7.9
132.2	9.3	133.2	8.4
132.2	8.7	133.2	7.9
132.2	6.0	133.2	8.5
132.2	9.3	133.3	7.6
132.2	7.8	133.3	8.3
132.3	8.2	133.3	6.6
132.3	7.3	133.3	9.0
132.4	10.5	133.3	8.6
132.4	9.3	133.3	10.1
132.4	7.6	133.4	8.1
132.4	7.6	133.4	8.8
132.5	8.1	133.4	8.2
132.5	7.6	133.5	8.0
132.6	7.7	133.5	8.0
132.6	8.1	133.5	7.9
132.7	9.1	133.6	9.0
132.7	8.4	133.6	8.4
132.7	8.5	133.6	7.9
132.7	8.9	133.6	7.6
132.7	9.0	133.6	8.3
132.7	8.1	133.6	8.3
132.7	9.0	133.6	9.7
132.8	8.4	133.7	8.2
132.8	8.5	133.7	7.0
132.8	9.1	133.7	7.7
132.8	7.3	133.8	5.2
132.8	9.8	133.8	8.7
132.8	9.2	133.8	8.4
132.9	9.1	133.8	9.5
132.9	7.2	133.9	7.7
132.9	8.4	133.9	7.9
132.9	9.4	133.9	7.8

Maximum Dry Unit Weight (pcf)	OMC (%)	Maximum Dry Unit Weight (pcf)	OMC (%)
132.9	7.5	133.9	6.7
132.9	8.5	134.0	8.9
132.9	7.9	134.0	9.1
134.2	8.3	134.0	5.8
135.0	7.3	134.0	6.6

Table 43: OMC and maximum dry unit weight determinations between 134 pcf and 136 pcf.

Maximum Dry Unit Weight (pcf)	OMC (%)	Maximum Dry Unit Weight (pcf)	OMC (%)
134.0	8.1	135.0	5.6
134.0	7.6	135.0	7.8
134.1	8.6	135.0	6.0
134.1	6.1	135.0	7.9
134.1	7.1	135.0	9.9
134.1	5.3	135.1	6.9
134.1	8.2	135.1	4.7
134.1	7.3	135.1	7.7
134.1	7.4	135.1	8.1
134.2	7.9	135.2	10.5
134.2	6.4	135.3	5.6
134.3	10.1	135.3	7.3
134.3	8.0	135.3	7.3
134.3	7.2	135.3	5.9
134.3	8.8	135.3	6.7
134.3	6.2	135.4	7.9
134.4	8.6	135.4	7.3
134.4	4.8	135.4	8.2
134.5	5.7	135.4	7.6
134.6	8.7	135.5	7.7
134.6	6.0	135.5	8.6
134.6	7.9	135.5	7.7
134.6	9.2	135.5	8.1
134.6	7.4	135.7	5.6
134.6	8.1	135.7	6.9
134.6	8.1	135.7	7.8
134.6	8.5	135.7	7.3
134.7	7.6	135.7	6.7
134.7	6.2	135.8	6.3
134.7	7.4	135.8	6.8
134.7	8.1	135.8	6.4
134.8	7.5	135.8	8.4
134.8	8.6	135.8	5.6
134.8	8.0	135.9	8.6
134.9	8.4	135.9	7.7
134.9	7.7	136.0	8.3
134.9	6.7	136.0	8.6
134.9	8.1	135.0	9.3
134.9	7.1	135.0	8.2
135.0	9.2		

Table 44: OMC and maximum dry unit weight determinations between 136 pcf and 138 pcf.

Maximum Dry Unit Weight (pcf)	OMC (%)	Maximum Dry Unit Weight (pcf)	OMC (%)
135.0	7.9	137.3	8.2
135.7	6.7	137.3	8.0
135.8	8.4	137.3	6.9
136.0	7.4	137.3	7.1
136.0	5.9	137.5	7.9
136.1	6.3	137.5	7.3
136.1	7.9	137.5	8.1
136.2	6.3	137.6	8.0
136.2	7.6	137.6	5.9
136.2	5.4	137.7	7.1
136.2	6.6	137.7	8.6
136.2	7.2	137.7	6.6
136.3	7.7	137.8	6.8
136.3	8.0	137.9	5.8
136.3	7.4	137.9	7.7
136.3	6.9	138.0	6.4
136.4	7.4	138.0	6.1
136.4	8.2	136.7	7.7
136.4	8.1	136.8	6.5
136.5	5.0	136.9	6.6
136.5	7.5	136.9	6.8
136.5	6.6	136.9	6.5
136.5	7.8	136.9	6.4
136.6	6.9	137.0	7.6
136.7	4.8	137.1	5.2
136.7	8.0	137.1	7.5
136.7	9.3	137.2	6.8
136.7	8.0	137.2	6.6
137.3	7.4	137.2	7.2
137.3	7.8		

Table 45: OMC and maximum dry unit weight determinations between 138 pcf and 140 pcf.

Maximum Dry Unit Weight (pcf)	OMC (%)
138.1	7.7
138.1	5.4
138.2	5.7
138.2	6.6
138.3	6.0
138.5	6.5
138.5	5.7
138.6	5.8
138.7	6.3
138.8	5.3
139.0	6.0
139.0	6.3
139.0	6.3
139.1	6.8
139.1	5.3
139.2	5.8
139.2	5.2
139.3	6.3
139.3	7.7
139.3	6.8
139.3	7.6
139.4	7.8
139.5	6.6
139.6	7.1
139.6	6.5
139.7	6.4
139.9	5.9
139.9	6.7

Table 46: OMC and maximum dry unit weight determinations between 140 pcf and 142 pcf.

Maximum Dry Unit Weight (pcf)	OMC (%)
140.0	6.1
140.0	5.1
140.0	5.4
140.3	5.6
140.4	7.0
140.5	5.8
140.5	6.4
140.6	7.2
140.8	5.6
140.9	6.0
141.0	5.5
141.1	5.2
141.2	6.6
141.2	6.4
141.3	5.4
141.3	5.4
141.3	5.1
141.5	6.7
141.5	5.6
141.5	6.0
141.7	6.0
141.7	5.4
141.8	7.8
141.8	5.7
141.9	6.6

Table 47: OMC and maximum dry unit weight determinations between 142 pcf and 144 pcf.

Maximum Dry Unit Weight (pcf)	OMC (%)
142.3	5.3
142.4	5.6
142.5	7.0
142.5	7.0
142.6	5.9
142.7	7.4
143.0	6.0
143.0	5.1
143.4	5.7
143.4	5.9
143.6	4.6
143.7	5.4
143.8	6.3
143.8	5.7
143.8	5.5

Appendix C: Surveys

Form 1:

Dear Survey Participant:

The South Dakota Department of Transportation has contracted with the South Dakota State University Department of Civil Engineering to conduct research on methods of granular material compaction testing. The research is to evaluate new methods and technologies for granular material compaction control and verification.

The main objectives of the research is as follows:

- Evaluate the adequacy of using families of curves for granular materials
- Identify existing and possible alternatives for determining target density of granular bases
- Determine whether an alternative method of testing compaction of unprocessed and recycled granular materials should be used

This survey has been designed to gather information from other agencies regarding current methods, testing frequencies, equipment, and training requirements for granular compaction control and verification.

The survey will be supplementary to NCHRP Synthesis 456 - Non-Nuclear Methods for Compaction Control of Unbound Materials, which was conducted in the spring of 2013 and completed by your agency.

This survey is being sent to state departments of transportation. Your cooperation in completing the questionnaire will ensure the success of this research. If you are not the appropriate person at your agency to complete this questionnaire, please kindly reply and let us know who the correct person is.

Please complete and submit this survey by September 30th 2016. We estimate it should take approximately 5-10 minutes to complete. We are happy to conduct the survey via telephone conference if that is more convenient for you. When finished or if you have any questions, please email or contact the Principal Investigator Dr. Allen Jones at allen.jones@sdstate.edu or 605-688-6467. Note that any supporting materials you wish to send can also be sent directly to Dr. Allen Jones.

1. Please select all types of materials in which compaction quality control has been used by your agency. (Select all that apply)
Options: (Sands, Gravel, Limestone, Recycled HMA, Recycled PCC, and Other)
2. If density-based criterion is utilized by your agency during quality control of granular materials, please indicate the method used to determine target density. (Select all that apply)
Options: (Standard 4-Point Proctor, Modified 4-Point Proctor, Standard 1-Point Proctor, Modified 1-Point Proctor, Test Strip, and Other)
3. What is your agency's experience with using families of curves developed from laboratory test data to determine target density for granular materials?
Options: (Implemented in field projects, Evaluated in research studies only, Demonstrated in usage, Plan to use in the future, Not used or evaluated,
4. If families of curves for granular materials are used by your agency, have the families of curves been adopted from another state agency?
Options: (Yes, No, I don't know, and Families of curves not used)
5. If families of curves are used for which of the following granular materials are they used to determine target density? (Select all that apply)
Options: (Sands, Gravels, Limestone, Recycled HMA, Recycled PCC, None, and Families of curves not used)
6. Would you recommend the use of any of the non-nuclear density devices implemented or evaluated by your agency for compaction quality control of granular materials?
Options: (Yes, No, I don't know, and Not used)
If Yes, please provide the device used.
7. Would your agency recommend the use of any of the stiffness/strength measurement devices used or evaluated by your agency for compaction quality control of granular materials?
Options: (Yes, No, I don't know, and Not used)
If Yes, please provide the device used.
8. Has your agency implemented or evaluated any Intelligent Compaction (IC) systems for compaction quality control of granular materials?

Options: (Yes, No, I don't know)

9. Based on your agency's experience would you recommend the use of Intelligent Compaction (IC) systems for compaction quality control of granular materials?
Options: (Yes, No, I don't know, and Not used)
10. Does your agency currently conduct compaction quality control of granular Bridge End Back Fill?
Options: (Yes, No, I don't know)
11. Please specify which of the following devices your agency would recommend for determining in-situ moisture content of granular materials? (Select all that apply)
Options: (Moisture Analyzer, DOT600, Speedy Moisture Tester, Field Microwave, Moisture Density Indicator, Electrical Density Gauge, Time Domain Reflectometry Devices (Nuclear Density Gauge), Oven or Stovetop, and Other)
12. Based on the stated objectives of our research and the questions asked within this survey; please feel free to provide any additional information that may be useful to our work. (e.g. additional granular material research studies, procedures, specifications, equipment, methods, etc.)
13. May our research team contact your agency regarding the questions provided within this survey?
Options: (Yes or No)
If Yes, Please provide the following contact information: (Name, Position, Email, Phone number)
14. Additional comments:

Thank you for taking our survey. Your response is very important to us. If you have any questions or comments, again please feel free to contact Dr. Allen Jones at allen.jones@sdstate.edu or 605-695-6467.

Form 2:

Dear Survey Participant:

The South Dakota Department of Transportation has contracted with the South Dakota State University Department of Civil Engineering to conduct research on methods of granular material compaction testing. The research is to evaluate new methods and technologies for granular material compaction control and verification.

The main objectives of the research is as follows:

- Evaluate the adequacy of using families of curves for granular materials
- Identify existing and possible alternatives for determining target density of granular bases
- Determine whether an alternative method of testing compaction of unprocessed and recycled granular materials should be used

This survey has been designed to gather information from other agencies regarding current methods, testing frequencies, equipment, and training requirements for granular compaction control and verification.

The survey results will be compared to NCHRP Synthesis 456 - Non-Nuclear Methods for Compaction Control of Unbound Materials, which was conducted in the spring of 2013.

This survey is being sent to state departments of transportation. Your cooperation in completing the questionnaire will ensure the success of this research. If you are not the appropriate person at your agency to complete this questionnaire, please kindly reply and let us know who the correct person is.

Please complete and submit this survey by September 30th 2016. We estimate it should take approximately 5-10 minutes to complete. We are happy to conduct the survey via telephone conference if that is more convenient for you. When finished or if you have any questions, please email or contact the Principal Investigator Dr. Allen Jones at allen.jones@sdstate.edu or 605-688-6467. Note that any supporting materials you wish to send can also be sent directly to Dr. Allen Jones.

1. Please select all types of materials in which compaction quality control has been use by your agency. (Select all that apply)
Options: (Sands, Gravel, Limestone, Recycled HMA, Recycled PCC, and Other)
2. If density-based criterion is utilized by your agency during quality control of granular materials, please indicate the method used to determine target density. (Select all that apply)
Options: (Standard 4-Point Proctor, Modified 4-Point Proctor, Standard 1-Point Proctor, Modified 1-Point Proctor, Test Strip, and Other)
3. What is your agency's experience with using families of curves developed from laboratory test data to determine target density for granular materials?
Options: (Implemented in field projects, Evaluated in research studies only, Demonstrated in usage, Plan to use in the future, and Not used or evaluated)
4. If families of curves for granular materials are used by your agency, have they been adopted from another state agency?
Options: (Yes, No, I don't know, and Families of curves not used)
5. If families of curves are used for which of the following granular materials are they used to determine target density? (Select all that apply)
Options: (Sands, Gravels, Limestone, Recycled HMA, Recycled PCC, None, and Families of curves not used)
6. Which of the following non-nuclear density devices have your agency implemented or evaluated for compaction quality control of granular materials? (Select all that Apply)
Options: (Sand Cone, Balloon Method, Electrical Density Gauge (EDG), Soil Density Indicator (SDI), and Other)
7. Would you recommend the use of any of the non-nuclear density devices implemented or evaluated by your agency for compaction quality control of granular materials?
Options: (Yes, No, I don't know, and Not used)
If Yes, please provide name the device used.
8. Which of the following stiffness / strength measurement devices have your agency implemented or evaluated for compaction quality control of granular materials? (Select all that Apply)

Options: (Clegg Hammer (CH), GeoGauge, Dynamic Cone Penetrometer (DCP), Light Weight Deflectometer (LWD), Portable Seismic Property Analyzer, Soil Compaction Supervisor (SCS), Briaud Compaction Device (BCD), Other, and None)

9. Would your agency recommend the use of any of the stiffness/strength measurement devices for compaction quality control of granular materials?
Options: (Yes, No, I don't know, and Not used)
 If Yes, please provide the device used.
10. Has your agency implemented or evaluated any Intelligent Compaction (IC) systems for compaction quality control of granular materials?
Options: (Yes, No, and I don't know)
11. Based on your agency's experience would you recommend the use of Intelligent Compaction (IC) systems for compaction quality control of granular materials?
Options: (Yes, No, I don't know, and Not used)
12. Does your agency currently conduct compaction quality control on granular Bridge End Back Fill?
Options: (Yes, No, and I don't know)
13. Please specify which of the following devices your agency would recommend for determining in-situ moisture content of granular materials? (Select all that apply)
Options: (Moisture Analyzer, DOT600, Speedy Moisture Tester, Field Microwave, Moisture Density Indicator, Electrical Density Gauge, Time Domain Reflectometry Devices (Nuclear Density Gauge), Oven or Stovetop, and Other)
14. Based on the stated objectives of our research and the questions asked within this survey; please feel free to provide any additional information that may be useful to our work. (e.g. additional granular material research studies, procedures, specifications, equipment, methods, etc.)
15. May our research team contact your agency regarding the questions provided within this survey?
Options: (Yes or No)
 If Yes, Please provide the following contact information: (Name, Position, Email, Phone number)
16. Additional comments:

Thank you for taking our survey. Your response is very important to us. If you have any questions or comments, again please feel free to contact Dr. Allen Jones at allen.jones@sdstate.edu or 605-695-6467.

The response to each question from each respondent are presented in Table 48 and Table 49.

Table 48: Detailed Responses to survey Form 1.

Question Number	Minnesota DOT	Ohio DOT
1. Please select all types of materials in which compaction quality control has been used by your agency. (Select all that apply)	Sand, Gravel Limestone, Recycled HMA, Recycled PCC	Sands, Gravel, Limestone, Recycled HMA, Recycled PCC.
2. If density-based criterion is utilized by your agency during quality control of granular materials, please indicate the method used to determine target density. (Select all that apply)	Standard 4-Point Proctor, Standard 1- Point Proctor	Standard 1-Point Proctor, Test Strip.
3. What is your agency's experience with using families of curves developed from laboratory test data to determine target density for granular materials?	Implemented in field projects, Demonstrated in usage	Implemented in field projects.
4. If families of curves for granular materials are used by your agency, have the families of curves been adopted from another state agency?	I don't know	No.
5. If families of curves are used for which of the following granular materials are they used to determine target density? (Select all that apply)	Sands, Gravels, Limestone	Sands, Gravels.
6. Would you recommend the use of any of the non-nuclear density devices implemented or evaluated by your agency for compaction quality control of granular materials? If Yes, please provide the device used.	Yes, DCP	Do not use.
7. Would your agency recommend the use of any of the stiffness/strength measurement devices used or evaluated by your agency for compaction quality control of granular materials? If Yes, please provide the device used.	No	Do not use.
8. Has your agency implemented or evaluated any Intelligent Compaction (IC) systems for compaction quality control of granular materials?	Yes	Yes.
9. Based on your agency's experience would you recommend the use of Intelligent Compaction (IC) systems for compaction quality control of granular materials?	No	No.
10. Does your agency currently conduct compaction quality control of granular Bridge End Back Fill?	Yes	Yes.
11. Options: (Moisture Analyzer, DOT600, Speedy Moisture Tester, Field Microwave, Moisture Density Indicator, Electrical Density Gauge, Time Domain Reflectometry Devices (Nuclear Density Gauge), Oven or Stovetop, and Other)	Speedy Moisture Tester, Field microwave, NDG, Oven or Stovetop	Field Microwave, NDG, Oven or Stovetop.

Table 49: Detailed Responses to survey Form 2.

Question Number	Indiana DOT	Texas DOT
1. Please select all types of materials in which compaction quality control has been use by your agency. (Select all that apply)	Sands.	All of them.
2. If density-based criterion is utilized by your agency during quality control of granular materials, please indicate the method used to determine target density.	Standard 4-Point Proctor, Standard 1-Point Proctor.	Standard 4-Point Proctor.
3. What is your agency's experience with using families of curves developed from laboratory test data to determine target density for granular materials?	Implemented in field projects.	Not used or evaluated.
4. If families of curves for granular materials are used by your agency, have they been adopted from another state agency?	I don't know.	Families of Curves not used.
5. If families of curves are used for which of the following granular materials are they used to determine target density? (Select all that apply)	Sands.	Families of Curves not used.
6. Which of the following non-nuclear density devices have your agency implemented or evaluated for compaction quality control of granular materials? (Select all that Apply)	Sand Cone, Balloon, Other.	Sand Cone, Electrical Density Gauge (EDG), Soil Density Indicator (SDI), NDG.
7. Would you recommend the use of any of the non-nuclear density devices implemented or evaluated by your agency for compaction quality control of granular materials? If Yes, please provide name the device used.	I don't know.	No.
8. Which of the following stiffness / strength measurement devices have your agency implemented or evaluated for compaction quality control of granular materials? (Select all that Apply)	Clegg Hammer, GeoGauge, DCP, LWD.	Clegg Hammer, GeoGauge, DCP, LWD, Portable Seismic Property Analyzer, Briaud Compaction Device.
9. Would your agency recommend the use of any of the stiffness/strength measurement devices for compaction quality control of granular materials? If Yes, please provide the device used.	I don't know.	Yes, LWD.
10. Has your agency implemented or evaluated any Intelligent Compaction (IC) systems for compaction quality control of granular materials?	Yes.	Yes.
11. Based on your agency's experience would you recommend the use of Intelligent Compaction (IC) systems for compaction quality control of granular materials?	No. Not at this point.	Yes.
12. Does your agency currently conduct compaction quality control on granular Bridge End Back Fill?	No.	No.
13. Please specify which of the following devices your agency would recommend for determining in-situ moisture content of granular materials? (Select all that apply)	Field microwave, NDG, Oven or Stovetop.	Field microwave, Oven or Stovetop.

8.0 REFERENCES

- AASHTO (American Association of State Highway and Transportation Officials). (2015a). “Standard Specifications for Transportation Materials and Methods of Sampling and Testing, Part 1A: Specifications.” In *AASHTO M 145 Standard Specification for Classification of Soils and Soil-Aggregate Mixtures for Highway Construction Purposes*. AASHTO, Washington, D.C.
- AASHTO (American Association of State Highway and Transportation Officials). (2015b). “Standard Specifications for Transportation Materials and Methods of Sampling and Testing, Part 2A: Tests.” In *AASHTO T 99 Standard Method of Test for Moisture-Density Relations of Soils Using a 2.5-kg (5.5-lb) Rammer and a 305-mm (12-in.) Drop*. AASHTO, Washington, D.C.
- AASHTO (American Association of State Highway and Transportation Officials). (2015c). “Standard Specifications for Transportation Materials and Methods of Sampling and Testing, Part 2A: Tests.” In *AASHTO T 180 Standard Method of Test for Moisture-Density Relations of Soils Using a 4.54-kg (10-lb) Rammer and a 457-mm (18-in.) Drop*. AASHTO, Washington, D.C.
- AASHTO (American Association of State Highway and Transportation Officials). (2015d). “Standard Specifications for Transportation Materials and Materials and Methods of Sampling and Testing, Part 2A: Tests.” In *T 191-14 Standard Method of Test for Density of Soil In-Place by the Sand-Cone Method*. AASHTO, Washington, D.C.
- AASHTO (American Association of State Highway and Transportation Officials). (2015e). “Standard Specifications for Transportation Materials and Methods of Sampling and Testing, Part 2B: Tests.” In *T 310-1 Standard Method of Test for In-Place Density and Moisture Content of Soil and Soil-Aggregated by Nuclear Methods (Shallow Depth)*. AASHTO, Washington, D.C.
- AASHTO (American Association of State Highway and Transportation Officials). (2015f). “Standard Specifications for Transportation Materials and Methods of Sampling and Testing, Part 2B: Tests.” In *T 272-15 Standard Method of Test for Family of Curves – One-Point Method*. AASHTO, Washington, D.C.
- Amini, F. (2003). “Potential Applications of Dynamic and Static Cone Penetrometers in MDOT Pavement Design and Construction.” No. FHWA/MS-DOT-RD-03-162 Final Report. Jackson State University Department of Civil Engineering, Jackson, MS.
- ASTM (American Society for Testing and Materials). (2014). *D 7830 / D 7830M-14, Standard Test Method for In-Place Density (Unit Weight) and Water Content of Soil Using an Electromagnetic Soil Density Gauge*. ASTM. West Conshohocken, PA.
- ASTM (American Society for Testing and Materials). (2016a). *D 2487-11, Standard Practice for Classification of Soils for Engineering Purposes (Unified Soil Classification System)*. ASTM. West Conshohocken, PA.
- ASTM (American Society for Testing and Materials). (2016b). *D 4253-16 Standard Test Methods for Maximum Index Density and Unit Weight of Soils Using a Vibratory Table*. ASTM. West Conshohocken, PA.
- ASTM (American Society for Testing and Materials). (2016c). *D 7830 Standard Test Method for In-Place Density (Unit Weight) and Water Content of Soils Using an Electromagnetic Soil Density Gauge*. ASTM. West Conshohocken, PA.
- ASTM (American Society for Testing and Materials). (2016d). *D 5874-16 Standard Test Methods for Determination of the Impact Value (IV) of Soil*. ASTM. West Conshohocken, PA.

- ASTM (American Society for Testing and Materials). (2016e). D 6951/ D 6951M-09 *Standard Test Method for Use of the Dynamic Cone Penetrometer in Shallow Pavement Applications*. ASTM. West Conshohocken, PA.
- ASTM (American Society for Testing and Materials). (2016f). D 2167-66 *Standard Method for the Determination of In-Place Soil Density by the Rubber-Balloon*. ASTM. West Conshohocken, PA.
- Ba, M. (2013). "Effect of Matric Suction on Resilient Modulus of Compacted Aggregate Base Courses." *Geotechnical and Geological Engineering: An International Journal*, 31(3).
- Briaud, and Seo, J. (2003). "Intelligent Compaction: Overview and Research Needs." Texas A&M University, College Station, TX.
- Brown, J. (2007). "Non-Nuclear Compaction Gauge Comparison Study" Report 2007-19 Final Report, State of Vermont Agency of Transportation Materials and Research Section. Montpelier, VT.
- Chang, G., Qinwu, X., Rutledge, J., Horan, B., Michael, L., White, D., Vannapusa, P. (2011). "Accelerated Implementation of Intelligent Compaction Technology for Embankment Subgrade Soils, Aggregate Base, and Asphalt Pavement Materials." No. FHWA-IF-12-002 Final Report. U.S. Department of Transportation, Washington, DC. DOI: 01357342
- Christopher, R. B., Schwarts, C., and Boudreau, R. (2006). "Geotechnical Aspect of Pavements." Publication No. FHWA NHI-05-037. National Highway Institute Federal Highway Administration, U.S. Department of Transportation, Washington, D.C.
- Dai, S. and Kremer, C. (2006). "Improvements and Validation of MnDOT DCP Specifications for Aggregate Base Materials and Select Granular Test." No. MN/RC-2005-32 Final Report. Minnesota Department of Transportation Office of Materials and Road Research, Maplewood, MN.
- Drnevich, V. (2007). "A Study of Effective Soil Compaction Control of Granular Soils" Study C-36-3600 Final Report, Indiana Department of Transportation, Purdue University, Indiana.
- Ernest, S.B., IV. (2011). "Device Comparison for Determining Field Soil Moisture Content." Final Report, Geotechnical and Structural Laboratory, U.S. Army Engineer Research and Development Center, Vicksburg, MS.
- Ernest S.B., IV. (2013). "Non-Nuclear Alternatives to Monitoring Moisture-Density Response in Soils." Final Report, Geotechnical and Structural Laboratory, U.S. Army Engineer Research and Development Center, Vicksburg, MS.
- Ese, D., Myre, J., Noss, P., Vaernes. (1995). "The Use of the Dynamic Cone Penetrometer (DCP) for Road Strengthening Design in Norway." In *Proceedings of the 4th International Conference, Bearing Capacity of Roads and Airfields*. Minnesota Department of Transportation, St Paul, MN.
- Farrag, Khalid (2005). "Evaluation of Soil Compaction Measuring Devices." Final Report, Distribution & Pipeline Technology Division Gas Technology Institute, Des Plaines, IL.
- George, K. P., and Uddin, W., (2000). "Subgrade Characterization for Highway Pavement Design." No. FHWA/MS-DOT-RD-00-131 Final Report. University of Mississippi Department of Civil Engineering, University, MS.
- Horpibulsuk, Suksun (2009). "Modified Ohio's Curves: A Rapid Estimation of Compaction Curves for Coarse and Fine Grained Soils." *Geotechnical Testing Journal*, Vol. 32, No. 1.

- Joslin, J. G. (1958). "Symposium on Application of Soil Testing in Highway Design and Construction." In *Ohio's Typical Moisture-Density Curves*. Ohio State Highway Testing Laboratory, Columbus, Ohio. DOI: 10.1520/STP39322S
- Kim, H., Prezzi, M., Salgado, R. (2010). "Use of Dynamic Cone Penetration and Clegg Hammer Tests for Quality Control of Roadway Compaction and Construction." No. FHWA/IN/JTRP-2010/27 Final Report. School of Civil Engineering Purdue University, West Lafayette, IN. DOI: 10.5703/1288284314246
- Liu, C., and Evett J. (2000). *Soil Properties: Testing, Measurement, and Evaluation*. Fifth Printing, University of North Carolina at Charlotte. Charlotte, NC.
- Lockwood, D., V.M.P. de Franca, B. Ringwood, and M. deBeer (1992). "Analysis and Classification of DCP Survey Data, Technology and Information Management Programme, CSIR Transporteck, Pretoria, South Africa.
- Minnesota Department of Transportation (MnDOT). (2016). "Standard Specifications for Construction." MnDOT, St. Paul, MN.
- Nazzal, M. (2014). *National Cooperative Highway Research Program (NCHRP) Synthesis 456P: Non-Nuclear Methods for Compaction Control of Unbound Materials*. Transportation Research Board, Washington, DC. DOI: 10.17226/22431
- ODOT (Ohio Department of Transportation) (2017). "Supplemental Specifications 1015: Compaction Testing of Unbound Materials." Ohio Department of Transportation, Columbus, OH
- Rathje M, E. (2006). "Evaluation of Non-Nuclear Methods for Compaction Control." Texas Department of Transportation, Center for Transportation Research at the University of Texas at Austin, Austin, TX.
- Reid, R.A. (2001). "Soil Density Target Values", Study SD2000-02 Final Report, South Dakota State University Geotechnical Department, South Dakota Department of Transportation, Office of Research, Pierre, SD.
- SDDOT (South Dakota Department of Transportation) (2015a). "Standard Specifications for Roads and Bridges." SDDOT, Pierre, SD.
- SDDOT (South Dakota Department of Transportation) (2015b). "South Dakota Department of Transportation Materials Manual." *SD 104 Moisture-Density Relations of Soils, Aggregates, and Specified Mixtures*. SDDOT, Pierre, SD.
- SDDOT (South Dakota Department of Transportation) (2015c). "South Dakota Department of Transportation Materials Manual." *SD 105 Density of Soils / Granular Materials In-place by the Sand-Cone Method*. SDDOT, Pierre, SD.
- SDDOT (South Dakota Department of Transportation) (2015d). "South Dakota Department of Transportation Materials Manual." *SD 110 Density of Granular Material by Modified Sand-Cone Method for Thin Layers*. SDDOT, Pierre, SD.
- SDDOT (South Dakota Department of Transportation) (2015e). "South Dakota Department of Transportation Materials Manual." *SD 114 In-place Density of Soils and Aggregate by the Nuclear Method*. SDDOT, Pierre, SD.
- SDDOT (South Dakota Department of Transportation) (2015f). "South Dakota Department of Transportation Materials Manual." *SD 219 Determining Target dry density and In-place Density of Salvaged/Recycled Materials Using the Nuclear Gauge (Test Strip)*. SDDOT, Pierre, SD.

- SDDOT (South Dakota Department of Transportation) (2015g). "South Dakota Department of Transportation Materials Manual." *SD 108 Moisture Content Determination for Soils and Aggregate*. SDDOT, Pierre, SD.
- SDDOT (South Dakota Department of Transportation) (2016). Personal Communication with Technical Panel: Interview. June 20, 2016, Brookings, SD.
- Siekmeier J., Pinta C., Merth S., Jensen J., Davich P., Camargo F., Beyer M. (2009). "Using the Dynamic Cone Penetrometer and Light Weight Deflectometer for Construction Quality Assurance", Minnesota Department of Transportation, Office of Materials and Road Research, Maplewood, Minnesota.
- White, J.D.; Jaselskis, E.J.; Schaefer, R.V.; Cackler E.T.; Drew, I.; and Li, L (2004). "Field Evaluation of Compaction Monitoring Technology: Phase I." TR-495 Final Report, Center for Transportation Research and Education, Iowa State University, Ames, IA.
- White, J.D., Vennapusa, P., and Thompson J.M. (2007). "Field Validation of Intelligent Compaction Monitoring Technology for Unbound Materials." *Tech Transfer Summaries*. Paper 2, Minnesota Department of Transportation, Federal Highway Administration, Civil Construction, and Environmental Engineering, Iowa State University, Ames IA.
- White, J. D. (2009). "Accelerated Implantation of Intelligent Compaction Technology for Embankment Subgrade Soils, Aggregate Base, and Asphalt Pavement Materials." ER10-01 Final Report, Earthworks Engineering Research Center (EERC) Department of Civil Construction and Environmental Engineering Iowa State University, Ames, IA.
- Zambrano, C., Drnevich, V., Bourdeau, P. (2006). "Advanced Compaction Quality Control." Study C-36-36SS Final Report. Joint Transportation Research Program, Indiana Department of Transportation, Purdue University, Indiana.