

South Dakota State University  
**Open PRAIRIE: Open Public Research Access Institutional  
Repository and Information Exchange**

---

SDSU Extension Circulars

SDSU Extension

---

6-1951

## 4-H Project Guide: Poultry Production

Boyd Bonzer

Herb Lippert

G.S. Weaver

Follow this and additional works at: [http://openprairie.sdstate.edu/extension\\_circ](http://openprairie.sdstate.edu/extension_circ)

 Part of the [Agriculture Commons](#)

---

### Recommended Citation

Bonzer, Boyd; Lippert, Herb; and Weaver, G.S., "4-H Project Guide: Poultry Production" (1951). *SDSU Extension Circulars*. 549.  
[http://openprairie.sdstate.edu/extension\\_circ/549](http://openprairie.sdstate.edu/extension_circ/549)

This Circular is brought to you for free and open access by the SDSU Extension at Open PRAIRIE: Open Public Research Access Institutional Repository and Information Exchange. It has been accepted for inclusion in SDSU Extension Circulars by an authorized administrator of Open PRAIRIE: Open Public Research Access Institutional Repository and Information Exchange. For more information, please contact [michael.biondo@sdstate.edu](mailto:michael.biondo@sdstate.edu).



# 4-H Project Guide

Published by AGRICULTURAL EXTENSION SERVICE  
SOUTH DAKOTA STATE COLLEGE



TO MAKE  
THE BEST  
BETTER

## Poultry Production

By Boyd Bonzer, Herb Lippert and Dr. G. S. Weaver\*

### Requirements of A 4-H Poultry Project

Any boy or girl who wishes to enroll in the 4-H Poultry Project must be 10 years old on or before May 31; and must not have reached the age of 21 on January 1 of the current year. This boy or girl must be enrolled in the project before May 31. The 4-H member may have chickens, turkeys, ducks, or geese as the poultry project.

The chicks should be bought at a reliable local hatchery each year. The first-year member should raise one hundred or more baby chicks. The following years, the member should enlarge the project.

In taking care of the poultry project, the boy or girl should have the following things to do: the member should sell the eggs and birds and purchase the feed; improve the poultry houses and equipment; and keep a record of the money spent on the flock and received from the flock. A record also should be made of the amount and cost of equipment such as self-feeders, water fountains, and other similar equipment and supplies.

When the member has carried the project for four years, he should be taking care of the farm poultry flock. He also may have a full time program of producing broiler birds, a laying flock, or a blood tested breeding flock.

If the club member has turkeys, ducks, or geese as the poultry project, the following requirements must be met: The first-year members must start with 25 or more poults, ducklings, or goslings. The following years will require an enlargement of these projects. The member shall improve the houses and equipment and keep a record of production. The costs and money received from the project also will be kept in the record.

### Goals of A 4-H Poultry Project

Each 4-H member enrolled in the poultry project will work toward these goals: teach himself and fellow club members better ways to feed and care for poultry; stop diseases of poultry from getting into the flock by sanitation and proper care; learn to keep poultry parasites out of the flock and learn how to kill them; learn to feed and water the birds to get as many eggs as possible; learn to judge the

good birds from the poor; learn how to gather, store, and market the eggs and meat that the birds produce. If the 4-H club member learns all these things and practices them, he or she will have reached the goal—a good poultry man or woman.

### Planning the Poultry Project

One of the most common causes of lost profits and failure in poultry keeping is the lack of planning and foresight. A good poultryman is alert and wide awake; he is a person who spends a lot of time with small details—one who can watch his birds and sense when they start to get sick or go out of condition. He is a person who plans ahead and is prepared for the different phases of poultry management as the birds grow and mature.

#### Consider Facilities

When planning a poultry project, one should consider the different stages the birds will go through as they mature and be sure he has adequate facilities to properly care for the birds. It will be necessary to have space for brooding, a place to put the birds out on range on clean ground



Fig. 1. This is the start of your project. Choose your chicks with care. Buy from a reliable hatcheryman near home.

\*Extension Poultryman, District Club Agent and Extension Veterinarian, respectively. Assistance acknowledged to staff members of SDSC Poultry Department, Prof. Wm. Kohlmeier, head.

U. S. Department of Agriculture, Cooperating

In Furtherance Acts of Congress May 8, June 30, 1914

Extension Circular 471

Geo. I. Gilbertson, Director of Extension

June, 1951



### Early Hatched Pullets Make Best Egg Records

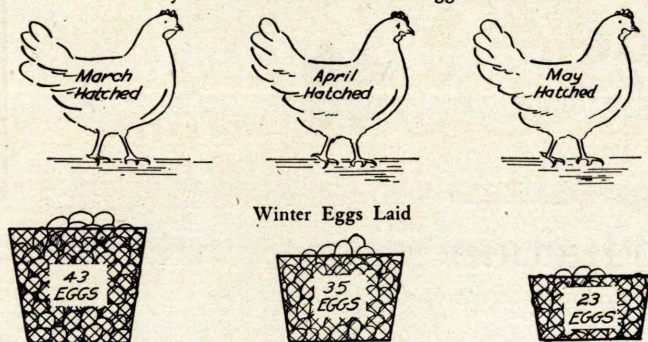

The Extra Eggs Are Produced When the Price Is High

Fig. 2. At the Massachusetts Agricultural Experiment Station, Rhode Island Red pullets hatched in March and April produced more winter eggs than pullets hatched in May.

and laying house space to house the birds when they come into production.

Much of the equipment can be constructed on the farm by a boy or girl who is handy with a saw and hammer. Figure 7 shows a range shelter that can be built. Fig. 9 is a feeder for the laying house. Fig. 8 shows an automatic water fountain that can be used in the brooder house, on the range and in the laying house. Building some of the equipment will save money and gives one a more personal interest in the project.

### What Breed to Buy

The aim of the project will somewhat determine the breed of birds to buy. Good egg production strains of Leghorns or Leghorn crosses should be purchased if the project is primarily for market egg production.

Good egg producing strains of Plymouth Rocks, New Hampshires or heavy crosses should be purchased if the project is aimed at producing poultry meat as well as eggs.

A broiler project will require a good broiler strain of bird that has been bred for meat production.

Buy baby chicks that are bred to produce the thing you want, be it eggs, meat or both meat and eggs.

### Where to Buy Chicks

Buy chicks from a reliable hatchery near home. Many cases of disease in baby chicks have been traced to long shipments on trains or trucks. Such diseases as Newcastle and bronchitis are airborne and will spread between the boxes of sick chicks to healthy chicks when they are stacked near each other in shipment. Chicks that are picked up at the local hatchery with the family car do not have contact with chicks from other places and will be as free of disease when you get them home as they were when they left the hatchery. If the hatcheryman is near he can be contacted easily if chicks are diseased when you receive them.

A reliable hatcheryman is one who sells chicks that are strong and healthy. He is one that carries on a good breeding program in his supply flocks and one who practices an intense blood testing program to eliminate pullorum disease in the hatching egg supply flocks.

A reliable hatcheryman will stand behind his chicks and provide replacements if unusual death losses occur.

### How Many Chicks to Buy

Three straight run chicks should be purchased for each pullet that will be housed in the fall. If sexed pullets are purchased one and one half pullets should be brooded for each mature pullet to be housed in the fall.

In a broiler flock a 5% death loss is considered high. It will not be necessary to buy very many more chicks than one plans to market for a broiler project.

Sexed heavy-breed cockerels are the best buy for a broiler project. Cockerels will grow a little faster than pullets and will produce a little more meat on the same amount of feed.

### When to Start Chicks

March and April are the months to start chicks for a laying flock. They will produce early fall eggs. Heavy breeds should be in good production when 6 to 7 months old; light breeds should be in good production about a month sooner.

Egg prices are usually the highest during the last four months of the year. (Sept., Oct., Nov. and Dec.) A project that is directed toward egg production should produce as many eggs during these months as possible.

## Managing and Feeding Chicks

The first few weeks are the critical time of a baby chick's life. Chicks that get a good start will have a better chance of developing into strong, healthy pullets and cockerels.

### Preparation Before the Chicks Arrive

The brooder house and equipment should be thoroughly cleaned and disinfected and things put in order several days before the baby chicks arrive.

### Clean and Disinfect House

Cleaning and disinfecting of the house and equipment should be done before the brooder house is moved to clean ground. This will keep the contamination from being spread to the new ground where the chicks will be allowed to run.

First remove all equipment such as stove, feeders, roosts, etc., and brush down the walls and ceiling with a broom.

Next clean and scrape the floor, being sure to get all the caked litter loose. A garden push hoe is a handy gadget for scraping the floor. Scrub the floor and lower walls with boiling hot lye water (1 lb. of household lye to 30 gallons boiling water). It is important to do a thorough job of scrubbing as a dirty surface can not be disinfected.

Now the house is ready to be disinfected. All parts of the inside of the house should be thoroughly soaked by spraying or brushing with a commercial disinfectant mixed according to the manufacturer's directions, or a solution of 5 tablespoons of lysol per gallon of hot water.

### Clean and Disinfect Equipment

Feeders, roosts and other equipment that are to be used in the house should have the same thorough cleaning and treatment with a disinfectant as the house and allowed to dry in the sun.

A wide putty knife and stiff scrub brush are handy tools to use when cleaning small equipment.

Caution should be practiced when working with boiling lye water as it will irritate the skin. A pair of rubber



gloves will protect the hands. Rinse with an abundant supply of clean water if any is splashed on the skin or in the eyes.

### Ready the House for the Chicks

Move the brooder house to clean ground where no poultry has been allowed to run for at least one year and two years if possible.

A permanent brooder house that cannot be moved should be provided with a sun porch.

The brooder stove should be set up and started at least three days before the chicks arrive. This gives the house a chance to dry out and the stove can be regulated so it will hold an even temperature (95° F at edge of hover, 2 inches above the litter). Any worn or broken parts should be replaced when the stove is started. An improperly regulated stove will result in overheated or chilled chicks and often

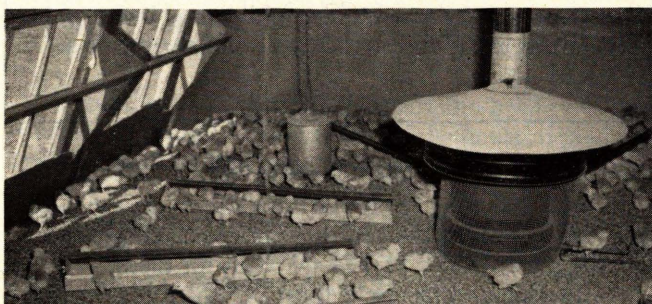

Fig. 3 (Top). Place feeders and fountains around the stove like spokes in a wheel. Note heavy paper rounding corners of house.

Fig. 4 (Center). Chicks should be encouraged to roost when they are three weeks old. Covering the roosting sections with wire on the under side will keep the chicks away from the droppings that accumulate under the roost.

Fig. 5 (Bottom). Sunporches can be used when it is necessary to use the brooder house on contaminated ground. The floor can be constructed of either 1" x 4" welded wire or 1" wood slats spaced 1" apart. Framework can be either steel or wood. Feed and water should be supplied on the sun porch.

causes disastrous results. When the floor is dry spread litter three or four inches deep. There are many good types of litter that can be used. Corn cobs ground to about the size of a walnut, cotton seed hulls, peat moss, sugar cane fiber, chalk rock, and chopped straw are all very successful litter. Brooder house litter should be fine and easy to stir. The droppings will mix with a fine litter rather than mat on top as they will with long straw.

Placing of feeders and waterers will be determined somewhat by the type of brooder stove in use.

Oil brooders heat the area under the hover and will raise the room temperature of the house. Feeders and water fountains should be placed around the stove in the form of spokes in a wheel. (See Fig 3.)

Bottle gas brooders heat, primarily, below the hover but also throw some heat out to the rest of the house. Some feeders and water fountains should be placed under the hover the first three or four days so the chicks will be able to eat and drink without going out in the colder temperatures away from the hover.

Electric brooders heat only the area below the hover. Put the feeders under the curtain, half out of the hover. Place some quart waterers under the hover for the first few days until the chicks start using those around the hover. During cold weather many chicks will never leave the hover until they get a few days old.

Be sure to follow manufacturer's recommendations with the type of stove in use. Do not overcrowd the unit. An oil brooder with 60 inch hover, a gas brooder with 72 inch hover and an electric brooder with a 4 foot by 6 foot hover will all care for 300 to 500 chicks. Do not overcrowd the hover space.

### Use a Chick Guard

A chick guard made of corrugated cardboard or other material should be placed in a circle around the hover about 3 to 4 feet out from the edge. A chick guard serves two purposes: It holds the chicks in near the heat, feed and water; and it helps eliminate floor drafts on the young chicks.

Move the chick guard back as the chicks grow and take it out when the chicks are big enough to jump over it.

Cardboard or other material may be used to round off the corners inside the brooder house. This will help eliminate the possibility of the chicks piling up in the corners from fright or cool temperatures.

### Feeder Space Requirements

Provide at least one inch of feeder space for each chick the first four weeks. As the chicks grow, larger feeders and more feeder space will be required.

## Starting the Chicks

Chicks should be started during day-light, preferably in the morning or early afternoon. This will give them a chance to find the feed and water and get filled up before darkness.

The egg yolk is taken into the body just before the chicks hatch and is used as a "lunch basket" to tide the baby chick over while it is getting started on feed and water.

In most cases day old chicks are ready for feed when they are picked up at the hatchery and should be placed in



the brooder immediately. Chicks that are picked up in late afternoon probably should be held in the boxes overnight and started on feed and water early the next morning.

### First Feed

Many hatcherymen recommend starting the baby chicks the first day on steel cut scratch grain or oat meal. They allow the chicks to fill up on this low protein feed before starting them on chick starter. This has a tendency to eliminate bowl trouble or a black pasting condition that often accompanies starting chicks on chick starter for their first feed. The feeders should be filled and additional feed spread on clean egg case flats or paper plates and placed under the hover before the chicks are put out. A chick naturally will pick at the handiest thing that looks like feed. By placing them on the feed they will start to eat immediately.

Change the egg flats or paper plates when they get dirty and discontinue their use entirely after 2 or 3 days.

After the chicks are two days old a handful of chick-size grit for each hundred chicks can be spread on the feed in the feeders every other day. When the chicks are 10 days old, hand-feeding grit should be discontinued and grit can be put in a low shallow pan where they can help themselves.

### First Water

The first 10 days or two weeks, baby chicks are not very big and do not require a great deal of water. But a good supply of clean fresh water should be before them at all times. Two or 3 one-quart jars with fountain bases are sufficient for each hundred chicks. More jars can be used to require less frequent filling.

Use an easy-to-clean glass or porcelain base for the jars. Keep them clean and sanitary.

Start some of the chicks drinking when they are placed in the brooderhouse by dipping their beaks in the water. Some chicks drinking will attract others. After the first 10 days or two weeks the quart fountains can be replaced by one 3 or 5 gallon fountain per hundred chicks or automatic fountains. (See Fig. 12.)

Larger fountains or automatic fountains will reduce the labor required to keep an ample supply of fresh clean water in front of the birds at all times.

## Brooding the Chicks

Crowding (due to overheating, chilling or frightening the chicks) can cause serious trouble. Some chicks can be injured to the extent that they will not grow and develop normally.

Manufacturers directions on the temperatures for various types of brooder stoves should be followed very closely.

Oil brooders will use a thermometer at the edge of the hover about two inches above the litter. Electric hovers usually have a thermometer installed in the hover.

An experienced poultryman can brood chicks without the use of a thermometer. He will watch the chicks and can tell if the stove is too cold or too warm.

When chicks are comfortable at night they will form an even ring a little way out from the hover of an oil brooder. They will distribute themselves evenly under an electric brooder.

Chicks will crowd to the outside walls if the stove is too hot and will crowd close to the stove when the room is cool.

The brooding temperature should be as cool as possible and still have the birds comfortable. The chicks will feather faster and eat and drink better.

### Recommended temperatures for oil brooders:

	Hover temperature under edge of hover 2" from floor	room temperature
1st week	95° F	70-75° F
2nd week	90° F	70-75° F
3rd week	85° F	70-75° F
4th week	80° F	70-75° F

Some stoves may require a higher or lower temperature; manufacturer's directions should be followed closely.

### Install roosts early

Low roosts may be provided for the chicks when they are three weeks of age and they should be encouraged to use the roosts as soon as they are ready for them.

Allow about 6 inches of roost per chick for the first 6 weeks then increase the roosting space as needed to avoid crowding.



Fig. 6 (Top). Cockerels should be separated as soon as the sex can be determined and sold at 2½ to 3 pounds body weight.

Fig. 7 (Bottom). This is one type of range shelter commonly used. A 10 x 12 shelter will care for 125 to 150 pullets. Note the range feeders that protect the feed from wind and rain.



## Brooder House Sanitation

There is no wonder drug or medicine that will take the place of good brooder house sanitation. Once a brood of chicks get sick it will be harmed to a small or great extent, depending on the seriousness of the outbreak.

Water fountains should be thoroughly scrubbed with a stiff brush each day and disinfected weekly. Feeders should be thoroughly cleaned and disinfected before they are put into use.

Floor litter should be stirred with a fork or garden rake each day to keep it worked over and dry. The litter should be replaced if it gets wet and soggy. Wet litter encourages growth and spread of any disease organisms that may be present.

Provide screen platforms for feeders and water fountains. This will help keep litter out of the feed and water. Where clean range or a sun porch are available the chicks may be turned outside after they are three to four weeks old when the weather is good. This will help keep the litter dry.

Ventilation of the brooder house is another key to dry litter. Use as much air movement in the house as possible without cooling it down too much or causing drafts on the chicks.

Keep chicks away from water standing in pot holes on the ground. Dead animals and moldy grain are other things that can cause sickness in the flock.

## Separate Pullets and Cockerels Early

Pullets will grow and develop better if separated from the cockerels at about 6 to 8 weeks.

Weather permitting, the pullets can be moved to range shelters out on good clean range where they can be reared until they are about to come into production.

The cockerels can be held in the brooder house and marketed at 9 to 11 weeks as broilers when they weigh around 3 pounds. Leghorn or Leghorn crosses should go to market a little earlier than heavies. They tend to lose some of their tenderness after they weigh 2 to 2½ pounds.

In some cases it may be profitable to carry the cockerels to a heavier weight and caponize them. Chemical capons (di-ethylstilbestrol) will probably go to market most profitably at 6 to 8 pounds. Surgical capons may be carried until they weigh 8 to 10 pounds.

It is advisable to check with the producemen in your area and see if there is a good market for caponized birds before they get past the 2½ to 3 pound stage. With good management and feeding, a bird can be grown to 2½ to 3 pound on about three pounds of feed per pound of body weight. As the bird grows older it will take more pounds of feed to produce a pound of body weight and may not be profitable.

## Management Feeding on the Range

A good range, properly used, can save as much as 10 to 20 percent of the feed bill for a flock of pullets. The birds will be healthier if allowed to run on clean ground and away from other birds on the farm.

### Choosing a Range

A good range is a range that supplies an abundant supply of young succulent green feed for the birds over a long period of time.

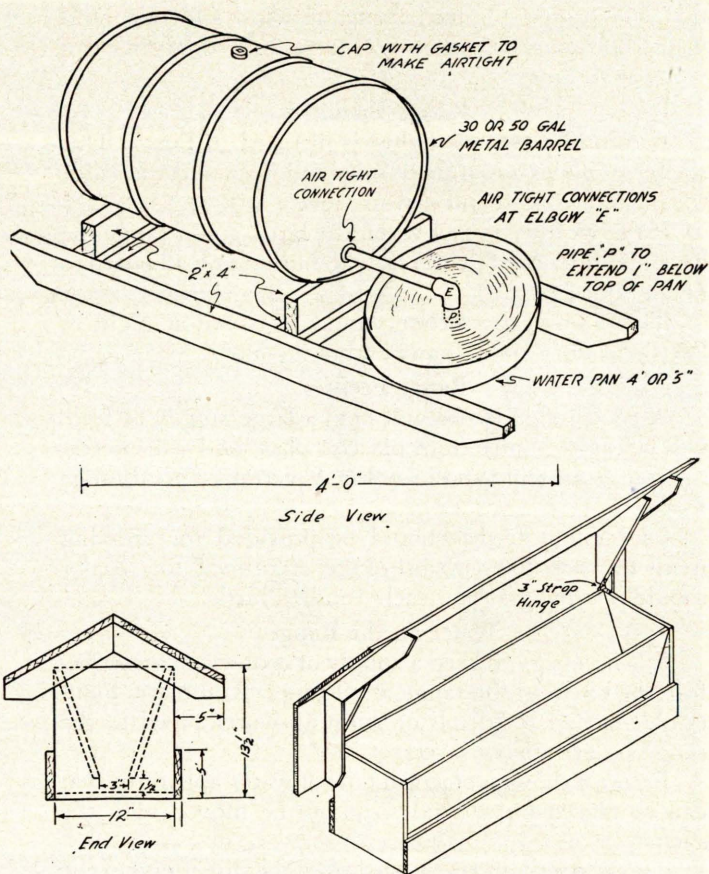

Fig. 8 (Top). On the range an old oil drum makes a satisfactory waterer. It can be made up as pictured or fitted with a hose and automatic water fountain. This unit should be placed in the shade so the water will stay cool.

Fig. 9 (Bottom). This outdoor range feeder is to be used when young chickens need larger feed hoppers—when the chickens weigh two to three pounds. This feeder is 5 feet long, 1 foot wide and 13½ inches high. The top boards extend out five inches to keep out rain and provide shade. This hopper is sufficiently large to reduce labor in refilling. Larger feeders as this one are higher from the floor or ground and prevent litter from being scratched into them.

Brome grass, alfalfa, or brome and alfalfa mixed make a good pasture for poultry. Oats, wheat or rye are other crops that can be used to good advantage. Small grains should be planted at different intervals during the summer to supply a constant supply of succulent green feed. Brome or alfalfa should be clipped, when it becomes tall and woody, so a new growth will start.

When the grasses become hard and woody they are not palatable to the birds and they will not eat the forage. The range may be located near a corn field where the birds can get additional shade during the hot part of the day.

The land should have a gentle slope where the range is located so that it will drain well and not have puddles of stagnant water standing after rains.

The range should be located on land where no chickens have been allowed to run for at least one year; two years is better. Chicken manure should not be spread on the land that is to be used for poultry range during the next one or two years.

### Range Equipment

Range equipment consists of: a shelter to protect the birds from the weather and predatory animals; feeders



that will protect the feed from the wind and rain; and water fountains that will provide an ample supply of clean water at all times.

### Range Shelters

A common type of shelter is pictured in Fig. 7. This shelter provides a roof, wire sides and floor and roosts for the birds. It is light and easy to move.

If the weather is cool when the birds go on range the back and sides can be covered with burlap or wall board to break the wind.

The door to the shelter should be closed at night to keep predatory animals away from the birds.

### Range Feeders

A good range feeder will hold a large supply of feed, will be easy to move from place to place and will protect the feed from wind and rain. Fig. 9 pictures a good range feeder.

One 5 foot feeder should be provided for growing mash for each 100 birds on range. Another 5 foot feeder should provide grain for each hundred birds.

### Water on the Range

It is necessary to keep a supply of cool, clean water before the birds on the range at all times. Automatic fountains attached to barrels or running water piped to the range are great labor savers.

Figure 8 shows a practical type of water apparatus that can be placed on a stand so it can be moved with the shelter.

The water should be shaded from the direct rays of the sun in order to keep the water cool.

One automatic water fountain should be sufficient for each range shelter unit.

### Harden Birds Before Moving to Range

The windows should be taken out of the brooder house a few days before the birds are to be moved to the range to give them a chance to harden-off and get accustomed to cooler temperatures that they will be subjected to in the range shelter.

### Feeding on the Range

A balanced ration on the range includes growing mash, grain, green feed and water. Grass and grain are not enough to develop the pullets into strong, healthy layers. Holding back on the protein feed will retard the growth of the pullets and it will take them longer to develop and come into production. Mash should be supplied at all times and can be fed at all different levels of protein from 16% to 26%. Total feed should contain about 15% to 16% protein and the amount of grain fed with the mash will vary with the protein level in the mash. Follow the feed companies' recommendations with the particular type of feed used.

A grain mixture of  $\frac{1}{3}$  oats and  $\frac{2}{3}$  corn can be fed in one 5 foot self-feeder for each 100 pullets. Additional grain may be spread on the range each day to encourage the birds to move away from the shelters and get more exercise. The grass or green feed should be clipped often so new shoots are growing at all times. If the grass is allowed to become long and woody the birds will quit eating it.

Care should be exercised in clipping the range. It should not be clipped too short. If clipped during dry weather the grass may not start to grow again until it gets moisture; or it may be killed out entirely.

### Range Sanitation

Sanitation on the range is an important part of range management. The range shelter should be moved to a new spot each week or so, or when the range starts to get worn out around the shelter.

Shelters should not be moved more than one or two hundred feet at a time. The birds will lose the shelter and want to roost on the same spot if the shelter is moved too far at once. Each time a shelter is moved, the droppings that have accumulated under it should be picked up and hauled away so the birds can not scratch in them.

Continually moving the birds to clean ground will help to keep the birds healthy. Contaminated ground will harbor coccidiosis, black head, worm eggs, cholera and other disease organisms.

Water fountains are easily contaminated by the birds and must be kept clean. Use the same precautions here as you would in the brooder house. Brush them out daily and disinfect them once a week.

Water fountains should be placed on a wire platform or moved often to eliminate the birds' drinking from puddles that may form.

### Vaccination on the Range

Where fowl pox and Laryngo Tracheitis are a problem on the farm, vaccination against them should be done on the range when the pullets are 12 to 16 weeks of age.

Vaccination should be done only when the birds are in good condition and when the weather is dry and warm. Contact your local veterinarian to have the work done or he may sell you the supplies and you can do the work yourself.

Vaccination for newcastle disease is not recommended at this time in our state. See the section on diseases (pages 15 and 16).

## Laying House Management

Egg production accounts for a high percentage of the poultry income in South Dakota. A profitable flock is one that will maintain 50% to 70% production throughout the laying year.

Chickens are different than most other animals in that when they are in good production they will respond very quickly to poor management. They can very easily be thrown into a molt and out of production for several weeks if routine management is changed quickly or some part of the daily routine is left out entirely for a couple of days.

### Preparation of the Laying House

A warm poultry house is a necessity in South Dakota where we have long, severe cold spells in the winter.

All the old hens should be sold two weeks to a month before the new flocks of pullets are to be housed.

The house should be cleaned and disinfected the same as the brooder house. Set all equipment (such as feeders, fountains, nests and dropping pit sections if they can be removed) outside. Sweep down the walls and ceiling with a broom. Clean and scrape the floor and lower wall surfaces until they are free of droppings. Wash down with boiling lye water and spray thoroughly with a good commercial disinfectant.

Scrape all equipment, scrub with boiling lye water and spray with disinfectant. Allow the equipment to stay in the sun and dry.



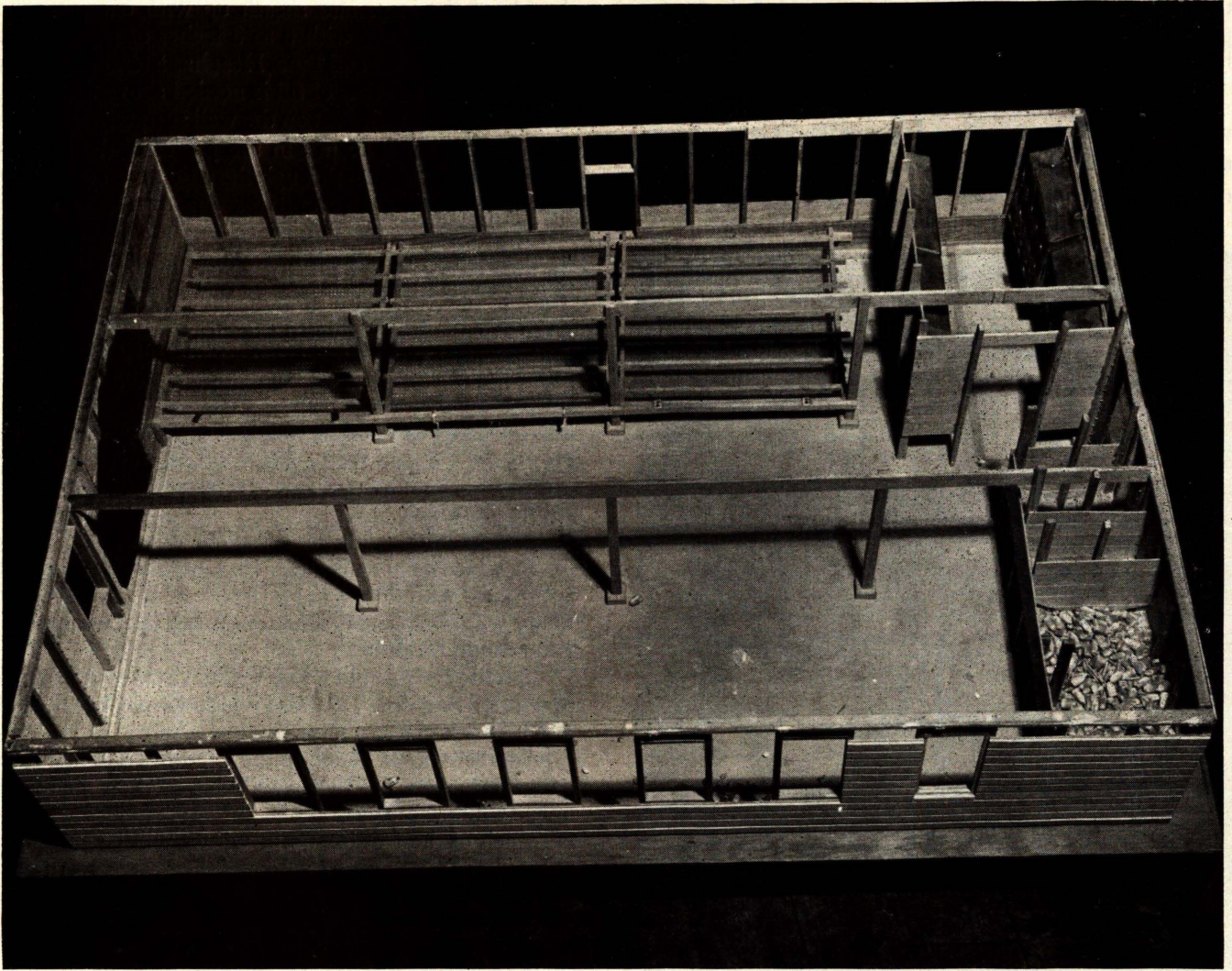

Fig. 10. The new South Dakota laying house has many labor saving conveniences. Dropping pits in the rear of the house; a laying room for all the nests in one corner of the house, and feed bins for a convenient supply of feed. The house is fully insulated and can use deep litter with the mini-

Spray the roosting and nesting areas of the house, dropping pit sections and nests, if wooden nests are used, with carbolineum or wood preserver. One thorough treatment should control mites for a year. Caution should be used when working with carbolineum so that it doesn't get on the skin as it will burn and blister where it touches. Carbolineum also will burn the skin of the birds if they come in contact with it before it is thoroughly dry.

Houses with dirt floors are a little harder to clean than those with cement or wood floors. A dirt floor can be soaked with disinfectant after it is cleaned or sprinkled with a layer of dry dip. If the old hen flock had a serious outbreak of disease the year before, it would probably be advisable to skim off four or five inches of soil and replace it with gravel or clean soil.

#### Repair and Remodel the House

Necessary repairs and remodeling should be done while the house is empty and before the birds are housed. Leaky roofs give rise to wet litter, and should be repaired. Broken window lights should be replaced. Broken or sagging doors should be repaired.

num of care. The house is 24' x 34' for 300 pullets. It can be constructed longer for more birds. House plans can be secured from the Agricultural Engineering Department, S.D.S.C., Brookings.

#### Insulation of the House

Insulation will pay for itself over a period of years in more eggs for less feed. It will make the house more comfortable for the birds in both extremely hot and cold weather. Insulation is the key to proper ventilation and the use of deep litter.

An insulation job need not be expensive. A waterproof paper (such as sisal craft) or an asphalt impregnated paper should be placed on the inside of the studding, then sheath up the inside of the wall with the cheapest lumber available. Fill the space between the studding with ground dry corn cobs (ground pea size), wood shavings, or sawdust if they are available. Mix about 1 pound of hydrated lime with each 10 pounds of fill to discourage rats and mice should they get in. Tamp the fill in as you work your way to the top of the wall. Cellotex in sheets two feet wide (or some similar material) can be used for sheathing on the inside wall and will not require a waterproof paper between it and the fill if it is painted with two or three coats of aluminum paint. Where the insulation board is used for sheathing, it should be protected by screen or boards where



the birds can pick at it. Two or three coats of aluminum paint on the wood surface add to the appearance of the house and preserve the boards.

The type of ventilation used will somewhat govern what is done with the ceiling. Slot ventilators and fan ventilation require a solid ceiling. This can be insulated much the same as the walls. Put a waterproof paper on the un-

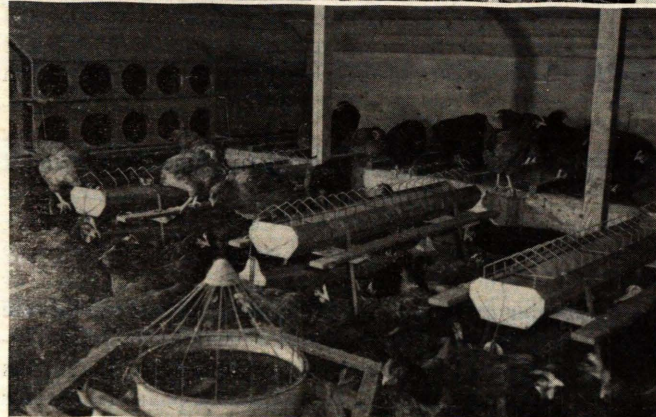

derside of the joists and sheath up with cheap lumber. Cover the attic floor with 6 to 8 inches of ground cobs, shavings or sawdust and lime. Heat has a tendency to rise, so at least 6 to 8 inches of fill is needed above the ceiling, a four inch fill is sufficient on the wall surfaces.

Louvers should be put in the gables of the house to allow some circulation through the attic to carry away any moisture that might accumulate due to a leaky roof or moisture escaping through the ceiling.

A door into the attic is handy for installing the insulation. The attic area also may be used for storing brooder equipment or other things, if there is room.

In some areas of the state, poultrymen are using a straw loft ceiling. In this case, poultry netting is strung on the joists and about 18 inches of clean straw placed in the loft. The straw should be changed every year. Many people are discouraged with a straw loft, however, because it is dusty and an ideal place for sparrows to nest. Some even report rat trouble.

An insulation job is not complete unless some form of storm windows are installed. Five percent window area (compared with floor area) is sufficient. If a house has too many windows, it may lose too much heat, as glass is a good conductor of heat.

In some cases an old house will have twice the number of windows needed. The extra windows may be taken out and used as storm windows on those that are left in.

Another way of doubling the windows is to nail transparent celo glass, or other glass substitutes on the outside of the window casings.

Much of the frosting-up in winter will be eliminated when storm windows are used and the heat loss will be reduced greatly.

### Ventilation of the Poultry House

Most uninsulated houses cannot be properly ventilated because the walls and ceiling are not warm enough to hold the heat in so it can be used to carry off the moisture through a ventilating system. Insulation of the walls and ceiling are a pre-requisite to proper ventilation.

There is no one answer to the problem of ventilating a poultry house.

In some houses, poultrymen are **ventilating through a straw loft** and doing a fair job. Straw loft ventilation has to be operated manually and requires a lot of attention if operated properly.

About 18 inches of straw is used in the loft. Cold air will circulate down through the straw to replace warm moist air that finds its way up through. Circulation over the

Fig. 11 (Top). This South Dakota house is 24' x 40' for 400 pullets. Note the feed bin doors and the door leading into the attic. Louvers in the gables provide ventilation through the attic. The door on the front is an addition to the original plan.

Fig. 12 (Top-Center). Automatic water fountains are labor savers when water can be piped into the house. Provide at least one fountain for each 100 to 125 pullets in a convenient place near the feed.

Fig. 13 (Bottom Center). A droppings pit, properly constructed, will catch about 65% of the droppings. It has to be cleaned only two or three times a year. Note the panels that raise from the rear and the convenient clean out door in the wall behind the pit.  $\frac{1}{4}$  in. hardware cloth for the front panels works better than 2" x 4" welded wire.

Fig. 14 (Bottom). This picture shows one waterer and 3 feeders, the requirements for each hundred pullets in the house. Three five foot feeders or two eight foot feeders provide the minimum space required. Less feeder space will generally result in lower production.



straw is governed by a door at least two feet square or larger in each end of the house above the straw. The doors have to be regulated according to the temperature outside and the wind direction. When the temperature is extremely cold the doors will be almost closed. When the wind is strong the door on the end away from the wind will be regulated and the other door closed.

**The slot ventilator** has proved very successful in Iowa and will work in our state if properly operated. A slot ventilator, like a straw loft, will require a lot of attention and will have to be adjusted with temperature and wind direction changes.

A slot ventilator is an opening across the front of the house, under the eaves, about 8 inches wide. A board cover is hung on hinges from the top and equipped with a bracket so it can be adjusted to any degree of opening.

Cold air comes in through the slot to replace warm moist air that goes out through the same opening.

**Ducts through the roof and cold air intakes in the walls** is another form of ventilation used in the state. This system also takes a lot of attention if it is to do a good job.

**Fan ventilation** is rapidly coming into use where farms have electricity. There are many types of fan ventilator systems. They all work on the same principle. A thermostat is used to control the fan. When the house gets warm the thermostat turns the fan on and pumps air out of the house, creating a low pressure area. Cold air comes in to replace the warm air. When the house has cooled down the thermostat will turn off the fan. Fans should be installed according to the manufacturer's directions as to area it will take care of and its location in the house. Fans are quite fool-proof and will operate themselves according to the setting of the thermostat. Many fan ventilators use a 1/20th horse motor that is very economical to run.

### Deep Litter

Deep litter is a labor saver. A house that is properly insulated and ventilated and not overcrowded will be able to use a deep litter. Deep litter should have to be cleaned out only once a year. Some poultrymen are using the litter the second and third year without cleaning the house if they haven't had a serious outbreak of disease on the litter. However, this is probably not advisable. Deep litter works on the principle of bacterial action breaking down the droppings into humus and releasing the moisture into the air to be carried off by a ventilating system.

Coarsely ground corn cobs, wood shavings, sawdust or chopped straw make good deep litter. Start with four or five inches on the floor when the pullets are housed. An inch of dry cow manure, top soil or even the litter from the brooder house if no disease outbreak occurred in the chicks while they were being brooded, will inoculate the litter with bacteria and help it start working. Starting a deep litter in warm weather will speed up the bacterial growth while it is getting started. Once it gets started working, it will produce its own heat and continue to work unless the temperature in the house gets down near freezing.

Stir the litter often with a fork, working the droppings into it. It may be necessary to take out some of the litter around the water fountains and feeders, where the traffic is heavy, if it gets too wet.

Hydrated lime mixed in the litter, a small amount at a time, will help to dry the litter if it has a tendency to get wet.

Adding a small amount of fresh litter from time to time, stirring it in well with the old litter, will help to keep the house dry. There is no advantage in having the deep litter over 7 or 8 inches deep. Some of the old should be removed if a great amount of fresh litter is to be added at any one time. Never take all the old litter out or the bacteria will be removed and the bacterial action stopped.

### Labor Saving Equipment

Dropping pits, nesting room and feed bins will save a lot of steps for the person doing the poultry chores.

Dropping pits properly constructed will catch about 65% of the droppings and are a great help in keeping the house clean and dry.

Pits are constructed with roosts about 18 to 24 inches above the floor, usually along the rear wall of the house. Roosts are constructed in panels usually not more than eight feet long for ease of handling. Provide about 8 inches of roost per bird in the house. 2" x 4" welded wire stapled to the top of the roosting frame and the bottom of the roosts will keep the birds from getting down into the droppings. The front and open sides of the pit should be screened with 1/4 inch mesh hardware cloth to keep the birds from getting under the roosts in the droppings. Hardware cloth will allow circulation of air under the roosts and dry out the droppings as they accumulate. Dropping pits need not be cleaned until they are full. A properly ventilated house will not have a smelly dropping pit. An objectionable ammonia odor can be overcome by sprinkling hydrated lime or super phosphate fertilizer on the droppings in the pit once a week. Super phosphate will increase the value of the droppings as fertilizer.

Bacterial action in the dropping pit creates heat that helps warm the house in extremely cold weather.

A nesting room is a labor saver for the person gathering the eggs and has many advantages. All the nests may be located in one place near the door and away from the heavy traffic around the feeders and water fountains. The litter can be kept cleaner in the nesting room area, resulting in cleaner eggs. The room can be darkened if the birds start cannibalism or egg eating.

The partition for the nesting room should be open 18 inches from the floor to allow the birds to walk under rather than go around to the door. A nesting room needs to be only wide enough to hang nests on both sides and allow enough room between to gather the eggs conveniently. Provide one nest for each 5 hens. Two- or three-tier nests will conserve wall space in the nesting room. (See fig. 20.)

Feed bins in the house for oats, corn and mash are a great labor saver. They should be large enough to hold at least a load of oats and a load of corn. The mash storage space can be smaller. (See Fig. 10.)



## Housing the Pullets

The pullets should be watched very closely when they are ready to start egg production. Their comb will redden up and their bodies will grow wide and deep. They should be put in the laying house just as they are coming into production and not later than when they are laying 5% to 10%.

Moving a flock after they are in heavy production will often throw them into a partial molt. A molting bird will hold back on egg production while it is growing feathers.

Do not house more pullets than you have room for. Provide around three square feet of floor space per bird, four feet is better. Overcrowding will hold some of the timid birds back so they cannot do their best.

### Feeding for Production

Percentage-of-production is the number of eggs gathered each day from each hundred pullets that are being fed in the house. It is the governing factor that determines profit and loss with the poultry project. 50% to 70% production throughout the laying year is considered good production in a flock. The higher the percentage-of-production the lower the feed cost per dozen eggs produced.

It is necessary to feed a balanced ration in order to get high production over a long period of time. A balanced ration consists of mash (or concentrate) and grain in relative amounts to give the pullet a 15% to 16% protein intake on total feed consumed.

A constant supply of oyster shell is required for laying birds. Grit is necessary for full utilization of the feed and an abundant supply of fresh clean water before the birds at all times is a must.

Laying mash can be fed in several different ways depending on the protein level. 16% laying mash should be fed as an all-mash ration. 20% laying mash should be fed 50-50 with grain. A good practice is to put mash in all the feeders and have it before the birds all the time. Give them about 1/3 of their grain by weight in oats in the morning and 2/3 of the grain by weight in corn in the evening before they go to roost. A flock in heavy production will eat 30 pounds of feed a day per hundred birds. This would be 15

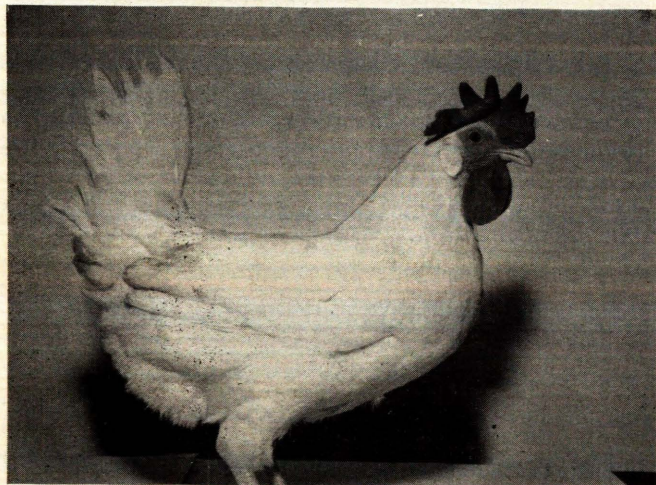

Fig. 15. A good layer has a large, red, waxy and full comb, her beak is bleaching or bleached. Her eye is bright and prominent and she has a neat and refined head, she is alert and friendly. Her body is wide and deep with worn and ragged feathers.

## South Dakota State College Poultry Mash

Ingredients	20% Chick Starter	20% Chick Grower	20% Laying Mash	26% Laying Concentrate
	Pounds	Pounds	Pounds	Pounds
Ground yellow corn	400	200	150	100
Ground Oats	170	150	185	100
Wheat—Standard middlings	50	150	200	200
Wheat Bran	50	150	200	200
Alfalfa Meal	30	100	40	60
Meat Scraps	120	50	140	180
Soybean Meal	120	150	70	135
Dried buttermilk or skimmilk	50	—	—	—
Salt Mixture	5	10	10	15
Steamed Bonemeal	—	40	—	—
Fish Oil (750 A — 300 D)	5	—	5	10
Vitamin B <sub>12</sub> and Antibiotic Supplement	+	—	—	—
Total	1000	1000	1000	1000

This chart shows the formula for mashes being fed at South Dakota State College. If one is to mix his own feed he should be careful to use the ingredients as shown and be sure to do a thorough mixing job. Often it is possible to buy commercially mixed feed as cheaply as a home-mixed ration can be made up.

pounds of a 20% mash, 5 pounds of oats and 10 pounds of corn. Some flocks will have a tendency to get fat on this much corn and if this happens the morning feeding of oats can be increased and the evening feeding of corn decreased. Still keep the 50-50 ratio of mash to grain.

25% to 27% protein mashes can be fed on a free choice basis. Fill half the feeder space with mash and half with oats. Let the birds balance their own diet during the day and give them a corn feeding in the late afternoon before they go to roost—about as much corn as they will clean up in 20 minutes. The mash-grain ratio on this system of feeding should be 1/3 mash and 2/3 grain.

Free choice feeding is probably most practical for the average farm. The maximum amount of home grown grains are utilized with this method.

32% to 35% protein concentrates can be used but should be diluted with ground grains to bring the protein level down to 25% or lower. Usually a flock will eat more of the concentrate than is needed if it is fed on a free choice basis. It probably won't hurt the bird but will increase the cost of feeding the flock, thus lowering the profit. (See SDSC Poultry Mashes, on this page.)

Provide at least two eight-foot feeders per hundred pullets on any of the feeding programs. Three feeders are better. It is false economy to give the birds less feeder space than they need.

When feeder space is short the timid birds will be crowded away and will not be able to maintain the proper feed intake to produce efficiently. They often will resort to filling up on what they can find by scratching in the litter while they are waiting for the stronger birds to move away from the feeders.

Provide one oyster shell hopper for each 75 to 100 pullets. Placing some of the hoppers on the back wall above the dropping pits will increase shell consumption. Birds need a good supply of oyster shell in order to put a good sound shell on the eggs.

Hen size granite grit or coarse bank run gravel should be provided at all times. Grit has no feed value but acts as a grinding agent in the gizzard and the birds are able to utilize the feed more efficiently.

At least 8 gallons of clean fresh water should be supplied to each hundred pullets daily. An egg is 66% water.



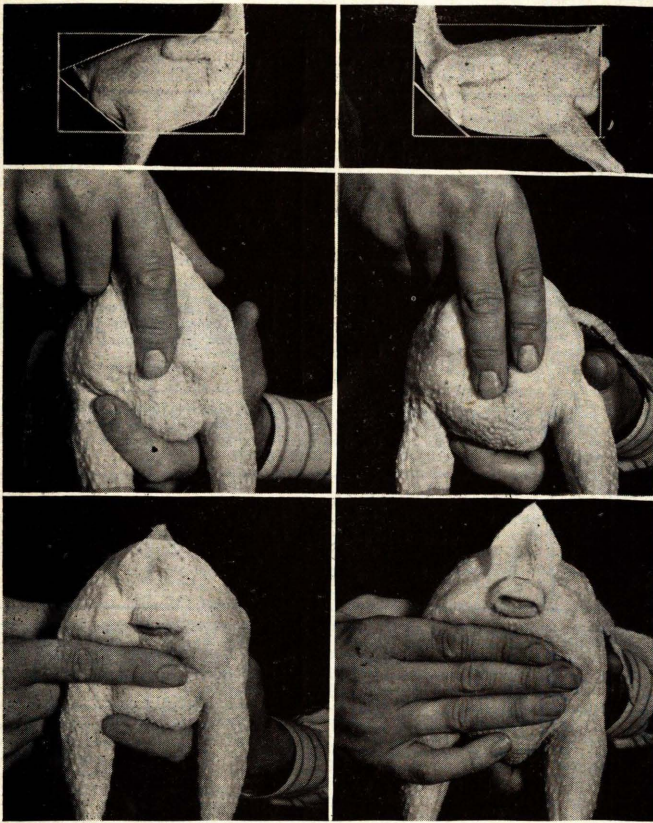

Fig. 16, 17, 18. It is necessary to handle the birds to do the proper job of culling. Keep the bird that has a body like the bird in the pictures at right. She has a long and deep body, at least two finger spread between the pubic or pin bones and three fingers spread between the pin bones and keel bone. Her vent is large and moist. Her abdomen is loose and pliable. The hen on the left is a cull, she has a short shallow body, only one finger spread between pin bones and one finger spread between the pin bones and keel bone. Her vent is puckerd and dry. Her abdomen is firm and hard. She is not in laying condition.

Water is also an important part of the hens body and is necessary for proper health and digestion.

Automatic fountains connected to a barrel or pressure line are labor savers. One fountain should be provided for each hundred to hundred and fifty pullets.

#### Culling for Production

Culling the flock frequently and removing the loafers is an important part of management of an efficient poultry project. Only well-developed, strong and healthy birds should be kept when the birds are housed in the fall. Small, undersized and unthrifty birds should go to market. After the birds have been in heavy production for a month or six weeks they should be culled again and all birds that are not laying removed from the flock. A good layer will have a large red and waxy comb, bleached or bleaching beak, a bright and prominent eye, and a neat and refined head. Her body will be wide and deep and her vent moist and bleached. She will have a spread of at least two fingers between the pin bones and three or four fingers up and down between the pin bones and keel. Her abdomen will be soft and pliable.

Poor layers or non-layers will have dry and shrunken combs, yellow beaks, dull and sunken eyes and a snaky narrow head. They will have narrow, shallow bodies. The abdomen is hard and pinched together with only a one-

finger spread between the pin bones and one- or two-finger spread up and down between the pin bones and keel bone. The vent will be small and yellow.

It is normal for some hens to go out of condition and out of production during the laying year. These hens should be removed from the flock as soon as they are noticed.

Diseased birds should be removed from the flock and disposed of by burning or burying where dog or animals will not dig them up.

In the spring and summer birds that start molting and go out of production should be removed from the flock and sold.

#### Care of the Broody Hen

Broody hens should be taken from the nest and placed in a wire or slat-bottomed coop for a few days. Keep in mind a hen that goes broody is a laying hen and should be salvaged if she can be broken of her broody spell without too much trouble.

Feed and water the broody hens just as you would a laying hen and she will go back to laying when she ceases to be broody.

Put a band on her leg, clip her tail or use some other method of identification when the hen goes into the broody coop. If she goes broody again soon after she is broken up she should be culled from the flock and marketed.

#### Watch for Cannibalism

Cannibalism or picking is quite common in flocks soon after they are housed. Pullets may rupture when laying oversize eggs. The rest of the birds will pick the exposed flesh and kill the bird. Once a flock starts picking it is pretty hard to stop them unless drastic measures are taken. Many remedies are suggested to stop picking. They range from adding a teaspoon of salt per gallon of drinking water to hanging a magazine in the house for the birds to pick at.

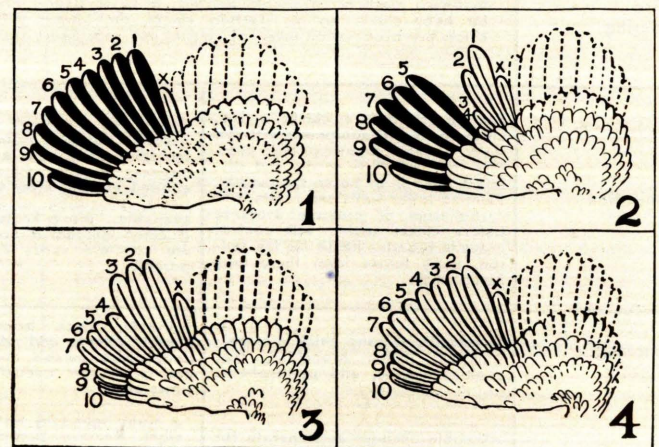

Fig. 19. Start to look for wing molt as early as June. Market the early molters. Diagram of wings at different stages of molt: (1) shows the 10 old primary feathers (black), the secondary feathers (broken outline), separated by the axial feather (x). At six weeks of molt a slow molter, (2), has one fully grown primary, and feathers 2, 3 and 4 are developing at 2 week intervals. In contrast, a fast molter, (3), has all new feathers. Feathers 1 to 3 were dropped first, now fully developed, feathers 4 to 7 were dropped next, now four weeks old, and feathers 8 to 10 were dropped last, now two weeks old. Two weeks later, (4), feathers 1 to 7 are fully grown. Ten weeks to complete entire molt as compared to 24 weeks for a slow molter.



# A Handy Brooding Guide

Age	First Week	Two to Four Weeks	Four to Eight Weeks	Eight to Twelve Weeks
<b>Brooding Temperature</b>	Before chicks arrive operate brooder stove at least a week at temperature recommended by manufacturer—usually 90° F. with thermometer at edge of the hover and 2 inches above litter—under hover in case of electric brooders. Winter brooding may require slightly higher temperatures.	Use manufacturer's directions. The usual recommendations are to reduce temperature 5 to 10 degrees per week until about 70 degrees F. is reached. A better guide to proper temperature is to regulate brooder to temperature at which chicks appear to be most comfortable. If temperature is correct, chicks will form a ring at night about six inches away from the edge of the hover, or spread out evenly under electric hovers.		In most instances, heat is entirely discontinued about sixth week. In brooding chicks in extremely cold weather, it may be necessary to provide a little heat to prevent crowding and piling.
<b>Type of House and Space Required for Floor Brooding</b>	Use a well-built, easily ventilated house of standard type. Allow at least one-half square foot of floor space per chick. Regardless of floor space available, do not brood more than 300 to 350 chicks under one hover. With conventional type brooder, allow 7 sq. in. floor area per chick under hover. When a large room with central heating system is used, there should be not more than two chicks per square foot of floor area up to eight weeks of age.		Not later than sixth week, separate cockerels from pullets and move cockerels to another house. If growing chickens are confined to house (no range) allow 1 sq. ft. floor space per bird.	If clean range is available, move birds to range. Provide one 10 by 10 ft. range shelter (or equivalent of other dimensions) for each 125 birds.
<b>Space Required for Battery Brooding</b>	Use manufacturer's directions. In most instances 10 sq. in. tray space per chick.	Use manufacturer's directions. In most instances, 20 sq. in. tray space per chick.	Use manufacturer's directions. In most instances, 30 sq. in. per chick to 6 weeks and 40 sq. in. to 8 weeks.	Use manufacturer's directions. In most instances, 55 sq. in. per chick 9 to 10 weeks and 75 sq. in. thereafter.
<b>Feeding Program</b>	Have feeders well filled with a good starting mash when chicks are placed in the brooder. Do not starve chicks—feed them as soon as possible. Adopt a feeding program recommended by a well-known commercial feed company, agricultural college or other approved agency and follow this program exactly as directed. Fine grit should be provided. Fine chick grain, given as the only feed the first two days, may help prevent "pasting up."		Continue with approved feeding program as recommended. Grain feeding is usually started at 4 to 6 weeks, but specifications of feeding program used should be followed. Continue grit. Supply green feed or green range if available.	
<b>Feeding Equipment</b>	Provide one linear inch feeder space per chick with simple, durable waste-proof feeders that are easy to clean and fill. In addition, place feed in shallow pans, box lids, or egg case flats, where chicks can find it easily for the first few days. If automatic feeders are used, follow the manufacturer's recommendations.		Not later than fifth week, change from small chick type feeders to larger ones of proper construction for larger birds. Provide 2 to 2½ linear in. feeder space per chick.	Change to range type feeders providing one 5 ft. mash feeder (or equivalent) and a grain feeder of similar size for each 100 to 125 pullets.
<b>Water Supply</b>	Provide at least two one-quart fountains (or equivalent in other types of fountains) for each 100 chicks. Use sanitary fountains that are easy to clean and fill. At the end of ten days to two weeks, change to larger fountains. They will save labor. One 5-gallon fountain will take care of 200 chicks. Automatic water fountains can be used after the chicks are a week to 10 days of age to maturity.		Continue to use larger fountains. As the chicks grow, raise fountains on blocks or put them on wire platforms to prevent litter getting into water.	When chicks are moved to range, supply range type watering equipment. Many types and styles are available. Use equipment that will keep plenty of clean water available constantly.
<b>Miscellaneous Equipment</b>	Use chick guard made of paper or other material to encircle the brooder, keeping chicks near heat, feed and water. Move back gradually and remove entirely by the end of a week.	Place feeders and fountains on slatted or wire covered platforms. If house is square, round out corners by tacking metal or wood strips across corners. Install low roosts at from three to six weeks of age.	Continue use of wire or slatted platform—use larger ones if necessary. Paint wood with creosote or carbolineum yearly at least 3 or 4 weeks before the equipment is used for chicks. Some place range feeders and fountains on a platform having skids or runners for convenience in moving. Increase roosting space as needed to avoid crowding.	
<b>Litter</b>	Absorbent litters, such as peat moss, cane fibre, mineral litter, or cottonseed, rice, oat, or peanut hulls reduce labor requirements as they can be kept dry by stirring them frequently and need not be replaced until they get damp. As a general rule, start with a layer of litter 3 or 4 inches deep and do not add more unless some must be removed because of dampness. Less absorbent litters, such as straw, are fairly satisfactory if free from mold and if they are changed frequently to keep dry.		Range shelters are usually equipped with wire floors, or a slatted floor made of planed 1" x 1" strips of wood, preferably a hard wood, can be used as a substitute for wire.	
<b>Wire Flooring</b>		Wire fabrics sometimes are used for brooder house floors. Any ½ to ¾ inch mesh welded wire fabric, hardware cloth or hexagonal netting, 15 to 18 gauge will be satisfactory. All of these are too large for baby chicks, so for starting chicks, such floors must be covered with paper and litter. Most chicks are brooded on litter, of course, and wire floors are used mainly in batteries and in range shelters.	For heavier birds and for floors in range shelters, 1 x 2 in., 14 gauge or inch mesh, 16 gauge hexagonal netting is used. When neither is available, a slatted floor made of planed 1" x 1" strips of wood, preferably a hard wood, can be used as a substitute.	
<b>Sanitation</b>	Four weeks before chicks arrive, clean house and equipment with lye water, a steam cleaner or high pressure sprayer. Allow to dry and disinfect interior of house thoroughly. Painting lower walls and roosts with carbolineum or creosote 3 weeks before chicks arrive will control mites in brooder house for the season. Fresh fumes from these may harm chicks.	Clean and disinfect whenever it becomes damp or odorous. Clean fountains daily with a stiff brush; disinfect weekly. Chicks may be allowed outside after two or three weeks, providing clean range is available. Move house frequently. If clean ground is not available, use concrete yards or wire sunporches.	Avoid water puddles and trash piles. Move feeders and fountains frequently to avoid contamination of ground. Under no circumstances should chicks of any age be allowed to mingle with adult birds or run over yards that have been used recently by adult birds. Be on guard against coccidiosis. There are a number of sulfa drugs and other compounds available for control. Administer as directed.	Special range shelters are usually provided at this age. They should be cleaned and disinfected, with woodwork and roosts painted with carbolineum or creosote at least 3 weeks before the birds are placed in them. Birds should be moved to clean ground and sanitation practices previously mentioned followed closely. Provide shade.
<b>Common Diseases</b>	Omphalitis (mushy chick disease), pullorum, chick bronchitis, tracheitis, mycosis, and paratyphoid.	Pullorum, chick bronchitis, tracheitis, rickets and other vitamin deficiencies, perosis, mycosis, round and tapeworms, coccidiosis (sometimes pox)	Same as previously described in second column. Also typhoid, cholera, lice, mites, Blue comb, Newcastle, and leukosis (range paralysis).	
<b>Miscellaneous Management</b>	Assemble brooder and operate for two or three days before chicks arrive. Arrange feeders like spokes of wheel to allow easy access from heat to feed and water. Keep feeders full. Some cover litter with burlap sacks or paper for first 2 or 3 days to prevent eating of litter.	A night light (7½ watts or equivalent) will help to prevent piling at night. Remove brooder stove when no longer needed. Separate pullets and cockerels. Prevent cannibalism by allowing plenty of room, reducing temperature rapidly, providing plenty of feeder space, covering windows to admit only subdued light, and allowing chicks outside as soon as possible. If picking starts, check these practices again; also smear special, red, bitter tasting, anti-pick salve on picked chicks and others. Windows may be painted red. An additional one or two percent of salt in the ration, or one tablespoon per gallon of drinking water for a couple of days, also may stop it.	Treat for worms as necessary. If pox or laryngotracheitis is prevalent in your community, vaccinate as a routine practice any time after birds are 6 weeks old. Newcastle vaccination can be done any time after chicks are 3 weeks old, using live virus vaccine. They may be vaccinated earlier with killed virus or intranasal vaccine.	

Reproduced through courtesy of Poultry Tribune, Feb., 1951



# Your Layer-Management Guide

Season	Before Housing	Fall Management	Winter Management	Spring & Summer Management
<b>Housing</b>	Many types of laying houses are available. Commercial producers sometimes prefer two or more story houses. Wide houses are preferred because they provide more comfortable conditions for the flock. Twenty feet is considered to be as narrow as any laying house should be built. Large capacity buildings may be 30 to 40 ft. wide. Providing three square feet of floor space for light breeds and four for heavies is a standard recommendation. One square foot of window space should be provided for each 20 to 35 sq. ft. of floor space.		Don't overcrowd. An insulated house is preferred for good winter production. Insulating board, fill type insulating material, bat and reflective types are all good when used properly. Good insulation reduces temperature fluctuations within the house, making it warmer in winter and cooler in the summer.	Painting the roof with reflective paint will help keep the house cooler. Large houses are more comfortable. Windows should be arranged to provide for cross ventilation during the hot summer days. All windows should be screened with heavy gauge poultry netting or wire fabric to prevent the entrance of wild birds.
<b>Feeding Equipment</b>	Use low feeders with perches. Feeders should be high enough to keep litter from being scratched into them. Grill or reels are necessary to keep birds out of feed. With most systems of feeding, one foot of feeder space is necessary for each three hens. Use heavy, substantial feeders. Provide hoppers for grit and calcium supplying products.		Keep equipment in repair. Don't overfill feeders. Placing feeders at right angles to light is recommended for small, poorly lighted houses. Placing them parallel with the length of the house is recommended for large, modern houses as it saves steps in filling. Have a central feed house or feed bin. It will help save time.	
<b>Watering Equipment</b>	Running water under pressure is a necessity for flocks of any size. Trough or fountain types, cup types and drip systems are all satisfactory when properly installed. Select a rigidly built fountain and install as recommended by manufacturer. Don't stint on water space. If water under pressure is not available, use one 8-gal. fountain for each 100 hens. If trough or fountain type equipment is used, plan to drain and brush it out each day. Keep all equipment clean and sanitary.		Use frost-proof, underground shut-off valves or electric soil heating cable to keep exposed supply lines from freezing. Keep water in open fountains warmed to 50 degrees F. There are many electric and kerosene lamp heating units available.	Each 100 hens will consume or waste 6 gallons of water a day. Keep water fresh and clean and always available. Lack of water in summer will cut production quickly. Unsanitary watering equipment is a disease hazard.
<b>Dropping Pits and Roosts</b>	Use properly built dropping pits and roosts. Pits should be 14" to 18" high. Roosts should be 12" to 14" apart, and 7" of roost space should be provided for Leghorns, 10" for heavies. 1" x 4" mesh 12 1/2 gauge welded wire fabric should be placed under the perches to keep birds out of pits. Other types of wire netting may be used but are not as satisfactory. Paint all pits and roosting equipment with creosote or carbolineum three weeks before housing. Be sure all pullets get on roosts the first week they are in the laying house.		If pits are deep enough and substantially built, they should need little attention other than to clean them two or three times a year. The use of lime or superphosphate over the droppings will help retain the fertilizer value of the droppings. If pits and roosts were not painted with carbolineum or creosote in the fall, watch for mites. They hide in cracks on perches. Spray with cresol solution if they are found. Occasionally spraying with DDT around roosting quarters will control flies during the summer months.	
<b>Ventilation</b>	Windows, slots, ventilation flues, and forced draft fan systems are used. Use one 40-watt bulb for each 200 sq. ft. of floor space, the bulbs poultryman. Use a system that has been found to be satisfactory in your area. If electric exhaust fans are used, the fan capacity usually recommended is two cubic feet of air per minute for each light breed hen and two and two-thirds for each heavy breed hen housed.		Protect birds from direct drafts. Close windows up as weather becomes more disagreeable. Check ventilating equipment to see that it is working properly. Don't close house up too tight.	Open windows and ventilators as weather becomes warmer. Provide plenty of cross ventilation during hot weather.
<b>Litter</b>	Deep litter is recommended. Start it early, during warm weather if possible. Use commercial litters, such as shredded cane fiber, treated cottonseed hulls, mineral litters, or peat moss. Other materials that can be used are chopped straw, wood shavings, or ground corn cobs. Avoid moldy litter. In starting, put in a light layer of litter over one-half inch of sand. Clean laying houses thoroughly before starting deep litter. From time to time, add new litter, until a layer five to eight inches thick is built up.		Add lime at rate of 1 lb. to 2 to 3 sq. ft. of floor space in case of dampness. To start deep litter during cold weather, put in thin layer of new litter and add old litter from pens where deep litter is already in use. Stir litter to keep from caking. Remove wet litter around fountains.	Keep litter evened up over floor of house. Don't let caked spots develop. Properly cared for deep litter may be used two or more years where diseases are not a problem.
<b>Selection and Culling</b>	Follow a good pullet rearing program. Pullets are no better than their breeding, plus the management and feeding provided by the flock owner.	House pullets as they mature. Put pullets of about the same maturity in each pen. Select strong, well-developed and pigmented pullets. Remove all those showing indications of leukosis or other diseases.	Cull out pullets that go bad, show signs of disease or indications of being poor producers. Large red combs and well-bleached legs and beaks in yellow-skinned breeds are signs of good producers.	Continue to cull as indicated for winter management, but now take molt into consideration. Early molters are poor layers. Watch for them and sell them as they develop. A few such birds will begin to develop in June.
<b>Lights</b>	Install a reliable time switch for controlling lights. It can be a switch for turning the lights on in the morning and off in the evening, or a morning switch only. If a uniform length day is wanted, the morning and evening switch should be used with a dimming device. Use one 40-watt bulb for each 200 sq. ft. of floor space, the bulbs being placed not more than 10 ft. apart. Lights are usually started in September or October, depending on date of hatch of pullets. The earlier hatched pullets should have lights first. Provides 13 to 14 hours of light a day.		Dust bulbs and reflectors occasionally. Irregularity in use of lights may cause molting. Replace damaged or burned out bulbs.	
<b>Feeding</b>	Most feeding programs are built around the mash used. All-mash, mash and grain hand fed, and free choice grain and mash are the three basic methods. Some producers favor one system, some another. Whatever system is decided upon should be followed carefully.	Use the range feed and feeding program for a few days after housing. Switch gradually to laying house program. Use a high quality ration and feed it as directed by the manufacturer. A source of grit and calcium should be provided in addition to regular ration. Some producers favor supplementary booster feeds to hold up production. Milk products, pellets, and wet mashes, are used according to manufacturers' recommendations, if wet mashes or pellets are used, don't overfeed. Provide only the amount that will be cleaned up in 20 to 30 minutes.		Booster feeds are often continued throughout the spring and summer. Stirring mash in feeders occasionally invites birds to eat. Don't put too much feed in feeders. Avoid waste at all times. Feed from day to day. Birds relish fresh feed at all times.
<b>Sanitation</b>	Birds should be vaccinated before housing for chicken pox and laryngotracheitis if those diseases are present in the area in which the flock is located. Vaccinate for Newcastle if present in your area, depending on how the disease is being handled in your state. Handle birds in clean coops and keep visitors out of the house. Screen houses against sparrows and other birds. Be sure all birds are free of lice when housed. House pullets in properly cleaned houses. Use a steam cleaner or hot lye water for cleaning.		Remove diseased birds as soon as noticed. Clean water fountains daily. Keep feeders clean. Watch birds for signs of lice infestation. Confined birds are less likely to pick up diseases. Don't introduce new birds until they have been treated for lice and isolated three weeks for observation. Be sure they have been properly vaccinated also. Bury or burn all dead stock, or dig a disposal pit to make disposal of dead stock easier. Plan to get on an all-pullet flock program if you are not on one at present.	
<b>Common Diseases and Parasites</b>	After housing, pullets should be watched carefully. Diseases that are apt to appear are Blue Comb and various respiratory diseases. Give an individual worm treatment at housing time if necessary. Treat for lice if necessary.		There are many diseases that may develop in the laying house. Leukosis infected birds may develop more pronounced symptoms. Cholera, typhoid, colds, Newcastle, pox, or laryngotracheitis may appear. Rely on your veterinarian and your state diagnostic laboratory.	
<b>Egg Handling Program</b>	In the laying house provide one nest for each 5 hens or one community nest 2'x8" in size for each 50 hens. Gather eggs in wire baskets.	Keep floor eggs gathered after housing to encourage laying in nests. Keep nests well padded with good nesting material.	Gather eggs three times a day. Follow deep litter program to insure drier litter and cleaner eggs. Take eggs from laying house to a cool, moist egg room for holding and packing. Pack all eggs small end down in clean fillers and flats. Market often, at least twice a week.	
<b>General Management</b>	Plan to use anti-picks, or debeak. Either will control cannibalism. Make arrangements to handle pullets with the least confusion.	Keeping complete records makes it possible to compare each year's operations and discover the weak points in management.	Be regular in feeding and chores. Study chore route and efficiency of routine in getting flock work done. Don't waste feed.	Keep flock confined. If males are kept, sell them after breeding season is over. Keep equipment in good repair.

Reproduced through courtesy of Poultry Tribune, Feb., 1951



Probably the most practical method of stopping picking in a flock is to debeak the birds with an electric debeaker. Take about half of the upper beak off. The cutting is done with a hot blade that sears over the wound and stops bleeding.

Many poultrymen debeak the pullets when they are housed in the fall.

Feed should be fed in the feeders when birds are debeaked. They will not have difficulty in eating from feeders, and will not be thrown out of production if debeaked when production is high. Some poultrymen are debeaking baby chicks when they start picking and are having good results.

## Egg Production and Marketing

Egg prices generally are higher the last four months of the year. Early chicks, properly managed and fed, will lay at a high rate during these high egg price months.

### Use Lights for Fall and Winter Production

During the fall and winter, daylight hours are too short. It is necessary to maintain a 13 to 14 hour working day for the flock to maintain high production. More than 13 to 14 hours of light is probably not practical. The time of day the lights are used is not so important as long as the lighting period is uniform. Some poultrymen will turn the lights on in the early morning, some will use evening lights and some will use morning and evening lights. Time switches can be purchased that can be set to turn the lights on or off at any desired time. When using morning or evening lights the length of daylight should be considered and the lights should be turned on and off to correspond with the changing length of daylight hours. Caution should be used to keep the lighting period uniform. Forgetting to turn the lights on one or two days in a row may throw a flock into a partial molt and seriously lower the egg production.

### Produce Clean Eggs

It is easier to produce clean eggs than it is to clean dirty eggs. A properly insulated and ventilated house with deep litter is a big help in producing clean eggs. Gather the eggs often and keep the nest litter clean. Don't let the birds roost on the nests at night. Provide about 1 nest for each 5 hens in a nesting room away from the heavy traffic in the house.

Dropping pits are another aid in producing clean eggs.

Confine the birds to the house at least until noon; all the time is better. Even with best care and management a few eggs will be slightly soiled. These can be cleaned with steel wool or sandpaper on a block of wood and should be cleaned soon after they are gathered.

### Gather Eggs Frequently in a Wire Basket

Eggs should be gathered at least three times a day and more often in extremely cold or hot weather. Most of the eggs will be laid by noon. A good schedule for gathering is 9:00 a.m., 12:00 noon, and 4:00 p.m.

The eggs should be placed in a cool, humid place, free from stale or musty odors, as soon as they are gathered. Ideal temperature and humidity are 40° to 60°F and 70% to 80% humidity. A cool basement or root cellar are probably the most practical place for egg storage on the farm.

Leave the eggs in the wire basket overnight to cool out thoroughly and pack them in the cases the following day.

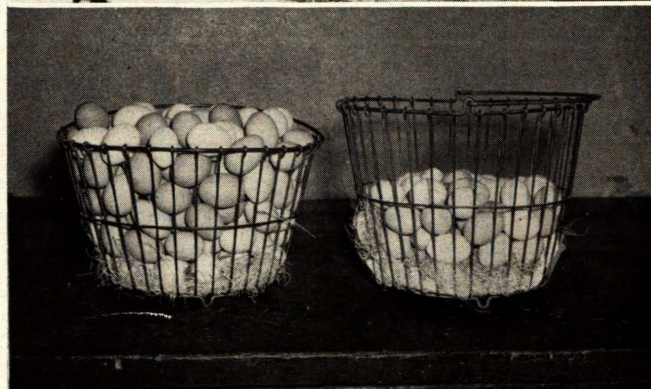

Fig. 20 (Top). A chicken hook is a necessary piece of equipment around a poultry flock. Birds can be caught for examination with very little disturbance to the other birds in the pen.

Fig. 21 (Center). Produce and market clean top quality eggs. Gather and cool the eggs in a wire egg basket. This allows the air to circulate freely around the eggs and cool them out quickly.

Fig. 22 (Bottom). Pack clean eggs in clean sound cases. Place the flats in the cases with cups up and always place the eggs in the case point down. Do not pack oversize or cracked eggs in cases as they will break and mess up the case during handling. Always cover the cases when marketing.

### Pack Eggs Properly

Always pack eggs point-down in the case. They will deteriorate very rapidly when packed small end up. Sort out odd shape, small, extremely large, cracked and extremely dirty eggs and use them at home. They will not bring top price on the market.

### Do Not Hold Eggs Too Long

Eggs that are held under ideal conditions should go to market at least twice a week. They should be marketed more often if the holding conditions are poor.

### Feed Affects the Quality of Eggs

Hens fed a uniform balanced ration will produce rather uniform colored yolks. Excessive green feed will darken



the yolk and make it less desirable to the consumer who is used to a light yolk. Many people look on dark yolks with suspicion. Inexperienced candlers may place the eggs with dark colored yolks into a lower grade.

#### Produce Infertile Eggs

Unless you have a breeding flock there is no good reason to keep male birds. They will eat expensive feed and destroy egg quality.

Fertile eggs break down in quality much more rapidly when exposed to heat than do infertile eggs.

#### Sell Eggs on Graded Basis when Possible

Good quality eggs are worth more money when sold on grade compared with a current receipt market. Certain times of the year there is a wider margin between top quality and current receipts prices. A person producing good quality eggs should take advantage of a higher price whenever possible.

## Poultry Diseases

For more detailed discussions on poultry diseases, see: SDSC Ext. Leaflet 123, "Newcastle Disease;" and USDA FB 1652, "Diseases and Parasites of Poultry." Both are available from your County Extension Agent.

### Pullorum Disease

Pullorum disease lowers the livability of chicks and reduces egg production of a laying flock. The mortality of chicks in an infected flock can be enormous, causing serious economic losses. Additional damage is caused by the fact that healthy chicks may acquire the disease by contact with infected chicks.

The disease is caused by a bacteria, *Salmonella pullorum*. The primary seat of infection is the ovary of the infected hen. Ordinarily, the hens and pullets show no outward symptoms.

This disease is common in chicks from the time of hatching until they are 3 to 4 weeks old. Infected chicks are disposed to huddle together, appear drowsy, listless and do not eat. The droppings are whitish, foamy and sticky and the death rate may run 50 percent or more. Chicks which survive to maturity become the future carriers.

Control of pullorum disease is, primarily, a flock problem; the incubator problem is more-or-less secondary. Carrier hens must be recognized and eliminated from flocks from which hatching eggs are taken. The best method of detecting pullorum disease in an adult flock is by the agglutination test, made by a trained person. Under the National Poultry Improvement Plan, the testing service is provided by the cooperating hatchery to those poultrymen supplying eggs for the hatchery. However, this does not eliminate the need for a strict sanitary program to be carried out by the hatchery.

**Important:** Buy chicks from near-by hatcheries which carry on effective testing programs. Don't have chicks shipped by public carriers.

### Coccidiosis in Chickens

When chickens are 3 to 5 weeks old and sometimes older, they frequently become infected with parasites known as coccidia. Coccidiosis is characterized by hemorrhages in the intestinal tract. It is manifested by weakness, passing of a bloody discharge and a high percentage of deaths.

The best way to prevent this disease is by a sanitary system of management that breaks the life cycle of this internal parasite.

### Disposition of the Laying Flock

The entire laying flock should be disposed of each year and a new flock of pullets raised.

It is not profitable to keep old hens over for a second year's production. Their potential production is only 70% to 75% of what it was the first year. They will be out of heavy production and molting the last four months of the year when the egg price is high. And they are potential disease carriers to the young pullets.

It takes almost as much feed to carry a hen through a complete body molt as it does to raise a new pullet.

The hens should go to market as soon as they go out of production and start molting in the late spring and summer. Two weeks to a month before the new pullets are to be housed, the entire flock of old hens should be sold so the house can be made ready for the new flock.

There are two types of coccidiosis in chickens—the cecal type and the intestinal type. In the cecal form, there is a rapid destruction of the lining membrane and a lot of hemorrhage. Many of the birds die suddenly. As the birds get older, the disease often affects the intestines, producing symptoms similar to the cecal type, but not quite as severe.

Prevention and control of coccidiosis consists of strict isolation of young birds from adult fowl and extremely careful sanitation. Medicinal treatment is not always successful but some sulfa drugs have shown promise. In the early stages, sulfaguanidine seems most effective while, in the later stages, sulfamethazine gives best results. Mix with feed according to directions on the container.

### Newcastle Disease

Newcastle disease is a highly contagious disease of chickens and turkeys. It is caused by a virus and characterized by respiratory and nervous symptoms. Mortality will range from 50% in young birds to 10% in old birds. The control of this disease is largely a sanitary problem. Two types of vaccines—killed virus and live virus (modified or active)—are being used with varied results.

When a bird is infected with Newcastle disease, it throws off this virus in the droppings and other excretions. Susceptible birds come in contact with infected materials, such as contaminated feed, and the disease is introduced into the well birds. The virus may be killed by sunlight, heat and various disinfectants such as cresol compound.

The most common method of introducing the disease into a flock is by the purchase of new birds, either chicks or adults. Chickens and turkeys of all ages are susceptible to attack by this virus. The average time between exposure and the development of symptoms is about five days.

Usually, the first symptom noticed is difficult breathing. The birds may wheeze, cough, sneeze, gasp or rattle. They are depressed and weak and sometimes a stupor develops. Nervous symptoms soon are apparent. Twitching of the head and neck, paralysis, shaking, jerking, walking in circles and other convulsive movements frequently occur. Incoordination of muscles may be complete or partial. (See Fig. 23). The onset of the disease is sudden and some unexpected deaths may occur. In laying flocks there is a total loss of egg production for 4 to 6 weeks.



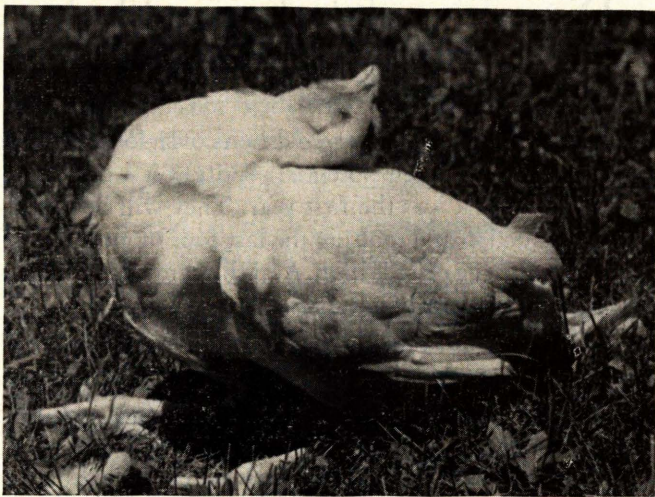

Fig. 23. This picture shows a bird in a condition of paralysis resulting from an attack of Newcastle disease.

The first thing to do is get a diagnosis. Consult your veterinarian. If Newcastle disease is diagnosed, notify the State Livestock Sanitary Board, Pierre, S. Dak.

No known medicinal treatment is effective. Control depends on sanitary management. If any birds are sick, the whole flock should be quarantined. If very sick, they should be destroyed, as they seldom will make economical gains. All dead birds should be burned or buried. Clean and disinfect the house and all equipment. Scrub the floors with hot lye water—one pound of lye to 30 gallons of water. Then disinfect the entire house with a good disinfectant, such as a 5% solution of compound cresol. Break the contact between infected and well birds!

Vaccination, as an adjunct to sanitation, has a place in preventing spread of the disease. Ask your County Agent for a copy of Extension Leaflet No. 123, "Newcastle Disease" for details on vaccination and other information on Newcastle disease.

## Fowl Cholera

Fowl Cholera is a highly infectious, rapidly fatal disease of both chickens and turkeys. It is characterized by weakness, difficult breathing and a high death loss.

It is caused by a germ which multiplies to enormous numbers in the blood and produces a septicemia or blood poisoning. It spreads rapidly throughout the flock by the feed becoming contaminated with the droppings from the sick birds.

Usually the first symptom is a yellowish coloration of the droppings. The bird becomes droopy, feverish and sits with the head drawn down. In the very acute cases, the birds may be found dead under the roosts, and symptoms are seldom noticed more than 24 hours before death. Some of the chronic cases may linger for a long time. If these chronic cases recover, they generally become carriers of the disease.

Treatment of the sick birds is almost futile. The aim should be to prevent the spread of the infection as much as possible. All sick birds should be destroyed and the carcasses burned. Healthy birds should be moved to clean quarters if possible.

The poultry house should be thoroughly cleaned and disinfected. The floor may be scrubbed with hot lye water, one pound of lye to 30 gallons of water. After the floor is

dry, the walls and floor should be disinfected with a 5 percent solution of compound cresole.

Recently, there has been some success in the treatment of this disease by the use of certain sulfa drugs such as sulfamethazine or sulfaquinoxaline, but these drugs will not replace a sanitary program.

## Fowl Paralysis or Leukosis

Fowl or range paralysis (leukosis complex) probably causes as great a loss to the poultry industry as all other diseases combined. About 18 percent of all laying chickens die each year from some disease and fowl paralysis is the cause of half the losses. A high percentage of the losses in young chicks and broilers is caused by the same disease. And not very much is known about its cause, its spread or how to control it.

There are five different forms of paralysis or leukosis affecting different parts of the chicken: nerve type, eye, internal organs, bone and blood. The nerve type is most familiar to poultrymen resulting in paralysis. The gray eye is also common. Big liver or internal type is often seen when the birds are opened. The bone type causes the bones in the legs and wings to enlarge and the blood type causes anemia—thin, weak and pale birds. A sick bird may have one or more of these forms.

Most research men believe the disease is caused by a virus but they are not absolutely certain. The fact that various types of the disease have been transmitted experimentally strongly suggests that it is of an infectious nature. The natural spread of the disease appears to occur in various ways such as the baby chicks from infected sources or the introduction of new breeding birds.

Under present knowledge, the poultryman must rely on sanitation and hygiene to prevent and control this disease. Sanitation and hygiene, of course, are the keystones of successful management in any poultry flock.

## Turkey Projects

Two bulletins are available at the State College Poultry Extension Office, Brookings, South Dakota for those who are interested in a turkey project.

They are: Turkey Manual, SDSC Ext. Cir. No. 401, and Turkey Raising, USDA, Farmers Bulletin, No. 1409.

## Duck Projects

USDA Farmers Bulletin No. 697, Duck Raising, is available at the South Dakota State College Extension Poultry Office, Brookings, South Dakota, for those who are interested in a duck project.

## Goose Project

USDA Farmers Bulletin No. 767, Goose Raising, is available at the South Dakota State College Extension Poultry Office, for those who are interested in a goose project.