

South Dakota State University  
**Open PRAIRIE: Open Public Research Access Institutional  
Repository and Information Exchange**

---

Fact Sheets

SDSU Extension

---

12-1-2005

## Biofilters

Richard Nicolai  
*South Dakota State University*

David Schmidt

Follow this and additional works at: [http://openprairie.sdstate.edu/extension\\_fact](http://openprairie.sdstate.edu/extension_fact)

---

### Recommended Citation

Nicolai, Richard and Schmidt, David, "Biofilters" (2005). *Fact Sheets*. Paper 106.  
[http://openprairie.sdstate.edu/extension\\_fact/106](http://openprairie.sdstate.edu/extension_fact/106)

This Other is brought to you for free and open access by the SDSU Extension at Open PRAIRIE: Open Public Research Access Institutional Repository and Information Exchange. It has been accepted for inclusion in Fact Sheets by an authorized administrator of Open PRAIRIE: Open Public Research Access Institutional Repository and Information Exchange. For more information, please contact [michael.biondo@sdstate.edu](mailto:michael.biondo@sdstate.edu).

## Biofilters

Richard Nicolai, South Dakota State University  
David Schmidt, University of Minnesota

This fact sheet is one in a series intended to answer — with science-based land-grant university research — questions frequently asked by the public about issues and needs affecting agricultural growth, urban expansion, and rural community development in South Dakota.

Odor emissions from livestock and poultry facilities have been reported to affect neighbors and communities at distances of a mile or more away under certain conditions. An odor control device that is both economical and effective in controlling this drift is a biofilter.

Biofiltration can reduce odor and hydrogen sulfide (H<sub>2</sub>S) emissions by as much as 95% and ammonia by 65%. The method has been used in industry for many years and was recently adapted for use in livestock and poultry systems. Biofilters work in mechanically ventilated buildings or on the pit fans of naturally ventilated buildings. Biofilters can also treat air vented from covered manure storage.

A biofilter is simply a layer of organic material, typically a mixture of compost and wood chips, that supports a population of microbes. Odorous air is forced through this material and is converted by the microbes to carbon dioxide and water.

Key factors influencing biofilter performance are the amount of time the odorous air spends in the biofilter and the moisture content of the filter material. Design issues include the sizing of the biofilter bed, selecting fans to push the air through the biofilter, choosing biofilter media, moisture control, operation and management, and cost of construction and operation.



## Biofilter configuration and elements

Biofilters can be either open or closed beds. Open-bed biofilters are the most common, typically 10 to 18 inches deep, and larger than closed-bed biofilters. Open-bed biofilters are typically built outdoors on the ground and are exposed to the weather. Closed-bed biofilters are mostly enclosed, with a small exhaust port for venting the cleaned air. Closed-bed biofilters usually treat smaller airflows and typically have deeper media (2-3 feet), reducing the space needed to achieve odor control, and are more expensive.

Figure 1 illustrates elements of an open-bed biofilter. They are:

- a mechanically ventilated space with biodegradable gaseous emissions;
- an air handling system to move the odorous exhaust air from the building or manure storage through the biofilter;
- an air plenum to distribute the exhaust air evenly beneath the biofilter media;
- a structure to support the media above the air plenum;
- porous biofilter media to act as a surface for microorganisms to live on, a source of some nutrients, and as a structure where moisture can be applied, retained, and available to the microorganisms.

Fig 1. Schematic of a typical open-bed biofilter.

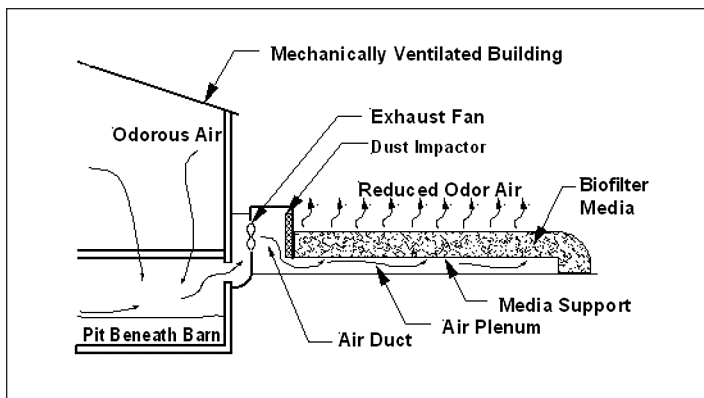

The odorous air is exhausted by a fan from the building and uniformly distributed beneath the biofilter media then rises through the media. Microorganisms attached to the organic media create a biofilm. In this biofilm, they oxidize the biodegradable gases into carbon dioxide, water, mineral salts, and biomass (more microorganisms). The cleaned exhaust air then leaves the biofilter.

## Biofilter design

Biofilter designs are based on the volumetric flow rate of air to be treated, specific air contaminants, and concentrations, media characteristics, biofilter size (area) constraints, moisture control, maintenance, and cost. These parameters all play a role in the efficient cleaning of airstreams or in economical operation of the biofilter.

**Airflow rate.** Biofilters should be sized to treat the maximum ventilation rate—typically the warm weather rate—of the building. This ventilation rate is dependent on the type, size, and number of animals in the building.

Proper ventilation design procedures can be found in MWPS-32, Ventilation systems for livestock housing. Some building ventilation rates are shown in Table 1.

Biofilters treating air from a manure storage unit will treat a lesser volume of air with a higher concentration of odorous gases. Typical airflow rates from covered manure storage are 0.01 cfm per square foot of surface area.

Table 1. Typical building ventilation rates (MWPS-32).

Facility type	Ventilation requirements, cubic feet per minute (cfm) per animal space		
	Warm weather	Mild weather	Cold weather
Nursery	35	15	3
Finishing	120	35	10
Gestation	150	40	12
Farrowing	500	80	20
Broiler/Layer (5 lb)	5	2.5	0.5
Turkey (40 lb)	32	14	3.2
Dairy (1400 lb)	470	170	50

**Media characteristics.** For a biofilter to operate efficiently, the media must provide a suitable environment for microbial growth and maintain a high porosity to allow air to flow easily. Critical properties of media material include (1) porosity, (2) moisture holding capacity, (3) nutrient content, and (4) slow decomposition. Table 2 lists characteristics for various biofilter media. Mixtures of these materials have the advantage of combining characteristics.

Because biofilter treatment efficiency depends on the microbial breakdown of volatile organic compounds, the number and type of microorganisms present in the biofilter are important. Natural media materials such as peat, loam soil, and compost normally contain sufficient microorganisms for a biofilter treating air from a livestock building or manure storage. However, a short conditioning period (2 to 3 weeks) may be necessary to allow the microorganisms to adapt to the odorous gases in the exhaust air. During this conditioning time biofilter efficiency is limited.

A proven organic media mixture for animal agriculture biofilters ranges from approximately 20:80 to 40:60 by weight of compost

Table 2. Biofilter media characteristics.

Material	Porosity	Moisture capacity	Nutrient capacity	Useful life	Comments
Peat	Average	Good	Good	Good	Good sources of microorganisms
Soil (heavy loam)	Poor	Good	Good	Good	
Compost (yard waste)	Average	Good	Good	Good	
Wood chips (3 in.)	Good	Average	Average	Average	Good additions for porosity
Straw	Good	Average	Poor	Poor	

and wood chips or wood shreds. The wood provides porosity and structure while the compost provides microorganisms, nutrients, and moisture-holding capacity. Media mixtures with more compost (less wood chips) will result in higher pressure drops but only slightly higher efficiencies.

Media lifetime may be 5 to 8 years or longer. During this time the media decomposes and becomes denser, which reduces the porosity (air space in the media) and increases the pressure needed to move the air through the biofilter media. As the airflow rate through the biofilter increases, the force needed to push the air through the media increases. This force is measured as the static pressure difference from the inlet side of the biofilter to the atmosphere. Static pressure also can be thought of as the resistance to air flow through the biofilter material. Resistance to air flow is fundamental to all ventilation systems and is typically reported in inches of water. Static pressure (pressure drop) between the inside and outside of a mechanically ventilated livestock building without a biofilter ranges between 0.04 and 0.12 inches of water (H<sub>2</sub>O).

In a biofilter, the relationship between airflow rate and static pressure depends on the type of media and media depth. Figure 2 shows this relation between Unit Airflow Rate (UAR, the amount of airflow per square foot of biofilter surface) and Unit Pressure Drop (UPD, the static pressure drop per foot of biofilter media depth) for a variety of materials tested in the lab. The lines shown are for media with different percent voids. Percent void is a measure of the amount of open pore space in the media.

Note that as airflow rate increases, the pressure drop through the media increases (as airflow increases it takes more pressure to push the air through the media). Also, as porosity increases, the pressure drop decreases. This porosity is both a function of the original media, compaction of the media, and media moisture content.

**Bucket test for estimating percent voids (amount of open pore space) in biofilter media:**

1. Start with two identical 5-gallon buckets.
2. Fill one bucket one-third full with media. Drop the pail 10 times from a height of 6 inches onto a concrete floor.
3. Add media to fill the same bucket two-thirds full and drop the pail 10 times from a height of 6 inches onto a concrete floor.
4. Fill the bucket to the top with media and once again drop the pail from a height of 6 inches onto a concrete floor.
5. Fill the bucket once again to the top edge of the pail.
6. Fill the second bucket to the top with clean water.
7. Slowly pour water from the second bucket into the first bucket containing media until the water reaches the top of the bucket.
8. Record both the total depth in the second bucket and the distance between the level of the remaining water and the top of the bucket.
9. Calculate the percent voids by dividing the distance from the water line to the top of the bucket by the total bucket depth and by 100.

*Modified from Composting and mulching: guide to managing organic yard waste. U of Minn Ext #BU-3296-GO.*

Porosity can also be affected by age of the media. Over time the media decomposes and settles, which reduces pore space. Any activity that causes compaction, such as walking on the media, also will reduce pore space.

Equation (1) is the relationship between void space (percent voids), Unit Airflow Rate (UAR), and Unit Pressure Drop (UPD) used for design. Percent voids is measured as:

$$UPD = 8.82 \times 10^{11} \times (\text{percent voids})^{-8.6} \times UAR^{1.27} \quad (1)$$

Fig 2. Media unit pressure drop and unit flow rate relations for various biofiltermedia.

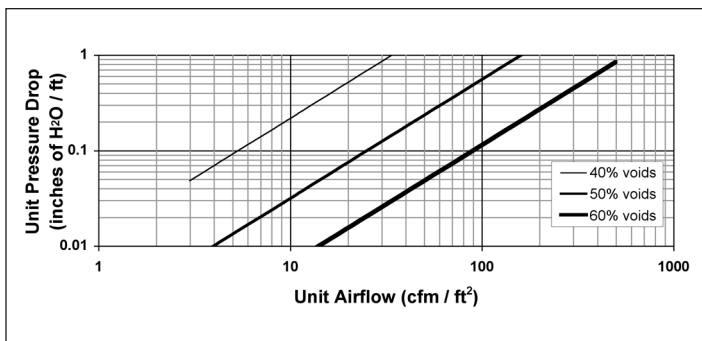

For livestock systems, biofilter media depth is typically 10 to 18 inches. Media depths greater than 18 inches result in excessive pressure drops and greater potential for compaction. Media depths less than 10 inches will dry out more quickly and have a greater potential for air channeling.

**Retention or Empty Bed Contact Time (EBCT).**

Retention time is the amount of time that the air is in contact with the biofilter media (figure 3). A longer retention time gives the biofilter a longer time to treat the odorous gases. Retention time depends on the specific gas (or gases) being treated and concentration of the gas (gases).

EBCT is determined by dividing the volume of the media (ft<sup>3</sup>) by the airflow rate (ft<sup>3</sup>/s). Actual contact time is much less than the EBCT because the media fills much of the biofilter bed volume, so the air flows through the pores in less time. EBCT is used in the calculations since actual contact time is difficult to measure.

Table 3 lists EBCTs to reduce odor and hydrogen sulfide emissions by 90%. These residence time requirements are not dependent on specific media. Instead, recommended contact times are based on average gas concentrations from typical facilities.

**Sizing a biofilter**

To determine the surface area of a biofilter requires knowledge of the volumetric flow rate, the EBCT, and the preferred media depth.

With a given airflow rate and selected EBCT, the biofilter media volume can be determined using the following:

$$V_m = Q \times EBCT / 60 \quad (2)$$

where:  $V_m$  = Media volume (ft<sup>3</sup>)  
 $Q$  = Airflow rate (ft<sup>3</sup>/min)  
 EBCT = Empty Bed Contact Time (s)

Table 3. Recommended minimum empty bed contact times for various livestock systems.

Livestock system	EBCT (s)	Ref*
Swine barn with deep pit manure storage	5	3,5
Poultry barns with dry litter	3	5
Covered manure storage units	10	5
Dairy heifer barn with deep pit manure storage	5	3

\* See references at end of fact sheet for full citation.

Figure 3. Residence time is expressed as Empty Bed Contact Time (EBCT).

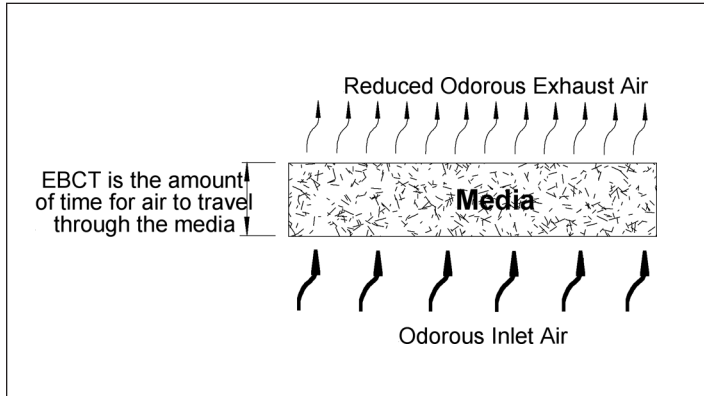

If biofilter space (area) is not limiting, a media depth can be selected and used to find the space needed.

$$A_m = V_m / D_m \quad (3)$$

where:  $A_m$  = Biofilter media area (ft<sup>2</sup>)  
 $D_m$  = Media depth (ft)

Next, calculate the Unit Airflow Rate (UAR) using the media area and airflow rate.

$$UAR = Q / A_m \quad (4)$$

where: UAR = Unit Airflow Rate (ft<sup>3</sup>/ft<sup>2</sup> s)

Use the UAR and Figure 2 (or Equation 5) to determine the Unit Pressure Drop (UPD) for the selected media.

$$UPD = 8.82 \times 10^{11} \times (\text{percent voids})^{-8.6} \times UAR^{1.27} \quad (5)$$

Multiply the UPD by the media depth,  $D_m$ , to determine the total pressure drop for the biofilter.

$$\text{Total pressure drop} = UPD \times D_m \quad (6)$$

The expected total pressure drop can be used with the building airflow rate to select the exhaust fan(s). If the total pressure drop is greater than desired, the depth selected and used in Equation 2 can be reduced to calculate new values of  $A_m$ , UAR, and UPD.

If biofilter space is limited, area can be selected as the first design criterion. The allowable area along with the calculated volume of material is used to calculate the depth.

$$D_m = V_m / A_m \quad (7)$$

The critical factor in sizing a biofilter bed is the residence time, which is the time for air to move through the filter. Residence time is determined by dividing the volume of the biofilter bed by the airflow rate through the bed.

## Relationship between EBCT and pressure drop

During hot weather the ventilation rate of the building increases and the odor concentration decreases. This lower odor concentration requires less contact time (EBCT) for cleanup.

This suggests that if summer ventilation rates are used for sizing a biofilter, then the design EBCT can be less than the values shown in Table 3. Reducing the design EBCT results in a smaller media volume and increased pressure drops through the media, given the same media depth, because of the increased air velocity.

To decrease this pressure drop, the media depth can be decreased. If this is not possible, the biofilter area must be increased, thus increasing the EBCT. Increasing the EBCT means a better filter efficiency, a lower pressure drop, more biofilter media, and a larger biofilter area. Building a larger biofilter can be justified due to the less powerful fans needed and the reduced operating cost of these fans.

## Fan selection

Fan selection requires knowledge of both design airflow rate and pressure drop. Typical agricultural ventilating fans are selected for the design airflow rate and a pressure drop of 0.10 to 0.12 inches of

### Example (Part 1)

Determine the dimensions and pressure drop of a biofilter for a 5,000 swine nursery facility with a hot weather ventilation rate of 35 cfm per pig (Table 1). Assume a 14-inch ( $D_m=1.17$  ft) biofilter bed depth of compost and woodchips. No "percent voids" measurement was determined.

- From Table 3 use a 5-second EBCT.  
 $Q = 35 \text{ ft}^3/\text{min}/\text{pig} \times 5,000 \text{ pigs} = 175,000 \text{ ft}^3/\text{min}$
- Using Equation 2  
 $V_m = Q \times \text{EBCT} / 60 = 175,000 \text{ ft}^3/\text{min} \times 5 \text{ sec} / 60 \text{ sec}/\text{min} = 14,580 \text{ ft}^3$
- Using Equation 3  
 $A_m = V_m / D_m = 14,580 \text{ ft}^3 / 1.17 \text{ ft} = 12,460 \text{ ft}^2$
- Using Equation 4  
 $UAR = Q / A_m = 175,000 \text{ ft}^3/\text{min} / 12,460 \text{ ft}^2 = 14 \text{ ft}^3/\text{min per ft}^2$
- Using Equation 5 or Figure 2 and a UAR of 14  
 $UPD = 8.82 \times 10^{11} \times (\text{percent voids})^{-8.6} \times UAR^{1.27}$   
 At 60% =  $UPD = 8.82 \times 10^{11} \times 5.1038 \times 10^{-16} \times 28.5 = 0.013$   
 At 50% =  $UPD = 8.82 \times 10^{11} \times 2.448 \times 10^{-15} \times 28.5 = 0.061$   
 At 40% =  $UPD = 8.82 \times 10^{11} \times 1.668 \times 10^{-14} \times 28.5 = 0.419$   
 The unit pressure drop (UPD) ranges from 0.013 to 0.419 inches per foot of media, depending on the percent void space.
- If porosity is not measured (% voids determined) use 40% voids. This will give the worst-case pressure drop.
- Using Equation 6, the total pressure drop through the media is  $0.419 \times 1.17 \text{ ft} = 0.49$  inches of water.

H<sub>2</sub>O to account for the pressure drop through the building. The pressure drop through a biofilter can range from 0.1 to 1.0 inches of water. This means that installation of a biofilter requires ventilation fans with the ability to move air through both the building and the biofilter—the sum of the two pressure drops.

For existing facilities, either the existing fans can be replaced with different fan characteristics, or additional fans, in series with the existing fans, can be added to provide the pressure necessary to push the air through the biofilter.

The range of ventilation rates needed to meet the barn ventilation requirements must also be considered. Fans must be sized to meet the minimum ventilation requirements of the animals and then staged to meet additional ventilation requirements as temperatures increase. This typically means a series of fans—some small and some larger—all controlled with an integrated temperature controller.

Use rated fans with known performance characteristics (Table 4, Fig 5). Typically, centrifugal fans are capable of providing higher pressures but less cfm at similar power requirements. Select fans to provide the airflow and pressure drop needed, using the manufacturer’s supplied information. The fan rating information should come from a recognized independent testing laboratory.

Fan shutters may be needed if more than one fan supplies a biofilter and one or more of the fans can cycle on and off. Shutters will prevent back drafting through fans that are not running. Another option is to use only one fan to supply each isolated biofilter section. In this case, each section of biofilter must be sized

according to the flow rate of the individual fan. Care in construction is needed to avoid air leakage between biofilter sections and concurrent back drafting through the fans.

Dust accumulation on fans, guards, and shutters can significantly reduce fan performance. Therefore, ducting design must provide access for fan maintenance and inspection. Also, select fans and motors that can operate in a corrosive environment. Fiberglass, stainless steel, and PVC materials are preferred over galvanized or carbon steel.

## Moisture control

Media moisture control is essential for odor reduction through a biofilter. Inadequate moisture can allow the media to dry out, deactivating the microbes and creating cracks and channeling of air that results in a reduction of filter efficiency. Too much moisture will plug some pores in the media, causing channeling and limiting oxygen flow in saturated areas of the filter, thus creating anaerobic zones in the biofilm.

Excess moisture is generally not a problem because the additional moisture drains through the media or evaporates due to the constant airflow through the biofilter. Recommended moisture contents for biofilters range from 40 to 65% wet basis (w.b.) for compost biofilters with an optimum moisture content of 50% (w.b.).

During the summer months, warmer temperatures and increased airflow may cause the media to dry out. Moisture can be supplied by sprinkling water directly onto the bed, which you can easily automate with a timer and a lawn sprinkler system. Sprinkling should be uniform throughout the bed.

During the winter months and cooler temperatures, moisture transfer to the media from the exhaust air prevents drying; therefore, no water addition is needed.

Excessive water from storm events or a watering system failure can cause moisture to seep out of the media. This water, known as leachate, can contain high concentrations of nitrate. Fortunately, the biofilter media is capable of absorbing most large rainfall events, so the potential for any leachate is relatively small. European design guidelines suggest a clay, concrete, or plastic liner under the

Fig 5. Example airflow rate vs. static pressure graph.

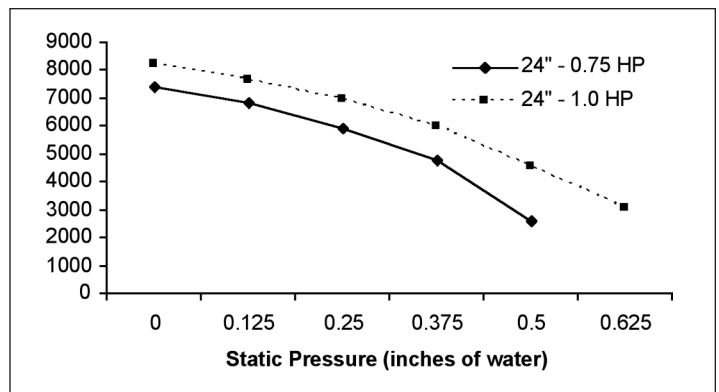

**Example (Part 2)**

Note the following changes in biofilter size and pressure drop if the EBCT in the previously worked example is increased by a factor of 1.5 or increases from 5 to 7.5 seconds. Hot weather ventilation rate remains at 175,000 cfm.

- Using Equation 2  

$$V_m = Q \times \text{EBCT} / 60 = 175,000 \text{ ft}^3/\text{min} \times 7.5 \text{ sec} / 60 \text{ sec}/\text{min} = 21,875 \text{ ft}^3$$
- Using Equation 3  

$$A_m = V_m/D_m = 21,875 \text{ ft}^3 / 1.17 \text{ ft} = 18,690 \text{ ft}^2$$
- Using Equation 4  

$$\text{UAR} = Q/A_m = 175,000 \text{ ft}^3/\text{min} / 18,690 \text{ ft}^2 = 9.4 \text{ ft}^3/\text{min per ft}^2$$
- Using Equation 5, a UAR of 9.4, and assuming 40% voids  

$$\text{UPD} = 8.82 \times 10^{11} \times (40)^{-8.6} \times 9.4^{1.27}$$
 gives a unit pressure drop (UPD) of 0.21 inch per foot of media.
- The total pressure drop through the media is  $0.21 \times 1.17 \text{ ft} = 0.25$  inches of H<sub>2</sub>O

The increase in EBCT (from 5 seconds to 7.5 seconds) resulted in a biofilter that is 1.5 times larger and a pressure drop that is nearly half of the original 0.49 inches.

Reducing the media depth can also reduce pressure drop. However, reductions in media depth below 10 inches will result in biofilter drying and reduced odor control.

Table 4. Example fan curve table for axial fans. Airflow rate versus static pressure.

Diameter (inches)	RPM	Motor HP	Static Pressure (inches of H <sub>2</sub> O)						
			0.0	0.125	0.250	0.375	0.500	0.625	0.750
12	2253	0.5	1904	1812	1719	1591	1429	1251	-
	2877	0.75	2432	2360	2287	2215	2126	2020	1905
18	1719	0.75	4040	3845	3635	3400	3120	2810	-
	1988	1	4660	4485	4290	4100	3900	3665	3385
24	950	0.75	7423	6813	5931	4740	2570	-	-
	1050	1.0	8180	7643	6925	5950	4550	3010	-
	1190	1.5	9270	8810	8240	7500	6600	5500	4100
30	774	1.5	12,000	11,270	10,350	9015	6016	2730	-
	850	2	13,270	12,580	11,786	10,820	9184	7220	-
36	704	2	15,740	14,890	13,720	11,525	9390	6980	-
	810	3	18,100	17,395	16,540	15,310	13,200	10,800	7200
48	494	3	27,410	25,635	23,405	20,650	16,845	12,500	-
	585	5	32,460	31,010	29,330	27,280	25,005	22,350	18,760

biofilter bed to collect the leachate. More testing and analysis are needed to determine the likelihood and pollution potential of biofilter leachate.

## Temperature

Microorganisms tolerate a range of temperatures. They are most active between 70 and 90° F. In winter, cooler temperatures will reduce microbial activity, but at the same time there is less airflow because of winter ventilation rates in the buildings. Most biofilters maintain temperatures well above freezing even in winter due to continuous flow of warm air from the building.

Biofilters on manure storages or on unheated buildings will freeze in cold weather, temporarily reducing the efficiency of the biofilter. As the biofilter heats up in the spring, the microorganisms become active again and the effectiveness of the biofilter is restored.

## Design of biofilters on naturally ventilated buildings

Biofilters are only effective when there is a captured air stream. This air stream is typically the fan exhaust from mechanically ventilated buildings or the exhaust from a nonporous covered manure storage. The air emissions through the sidewall of a naturally ventilated building typically cannot make use of a biofilter.

However, some naturally ventilated buildings use some mechanical ventilation in combination with natural ventilation. The mechanical portions of the ventilation are the exhaust fans on the pit or possibly sidewall fans that operate to provide minimum ventilation in the winter. For these types of facilities it is possible to install biofilters on the exhaust fans.

Total odor reduction achieved will be variable. During the cool months when most of the ventilation air passes through the exhaust fans and subsequently the biofilter, odor reduction is similar to that of mechanically ventilated buildings, or approximately 80-95%. However, during the summer months the primary means of providing air exchanges in the barn are through the natural

ventilation system (curtains and/or ridge vents). During these times, the odor reduction provided by installing a biofilter on the ventilation system is less, depending on the percentage total ventilation air treated.

In essence, the amount of odor reduction achieved with the biofilter is directly related to the percentage of air moving through the biofilter (vs. the natural ventilation system). The warmer the ambient temperature the higher percentage of ventilation air that is unfiltered and thus the lower the odor reduction for the total building.

During the summer ventilation mode with the curtains opened, the exhaust air is not controlled and is dependent upon the wind. Also, with very little or no pressure drop across the slatted floor, parts of the barn experience up-drafting due to buoyancy while in other areas air is moving down through the slats. Thus, pit gases can rise to the animal environment zone and be exhausted uncontrolled through the open curtain.

To achieve pit gas odor reduction through biofiltration, up-drafting through the slatted floor should be eliminated when the curtains are open. For example, in a curtain-sided swine finishing barn, a minimum ventilation rate of 45 to 50 cfm per pig is recommended to achieve complete down-draft when the curtains are opened.

One preliminary study was completed on a totally mechanical ventilated swine barn that exhausted 31% of the total ventilated air through the pit and the balance through the wall. (A mechanical ventilated barn was used to control and measure the air flow through the pit vs. the wall.) The air exhausted through the wall fans had 84% less odor and H<sub>2</sub>S concentrations (Fig 6)

One means of increasing the odor reduction efficiency for naturally ventilated buildings is to increase the percent of airflow through the biofilter by increasing the number or size of the fans, thus converting the building to more mechanical ventilation. It is clear that to achieve good odor control a large percentage of a building's exhaust ventilation air will have to be routed through the biofilter.

## Biofilter construction

**Siting.** The biofilter bed should be located close to the exhaust fans to limit the length of ducting but far enough from the building that it is not hit by roof runoff. It is also important to construct the biofilter in an area where water will not pond near the ducting, plenum, or fans. Keeping this area dry will increase the life of the system.

Typically, the organic material absorbs most of the rain or snow that falls on an open-bed biofilter. However, during periods of high rainfall or in the event of a sprinkling system failure, there is the potential for water to leach out of the organic material. Therefore, the biofilter bed should be built on a sloped, well-drained area so excess water can move away from the biofilter.

**Ductwork and plenum.** Ducting must be constructed to move the air from the fans to the plenum of the biofilter (Fig 7). Materials to construct both ducting and plenum must be smooth and resistant to rotting or corrosion. These ducts must be sized in such a way to minimize pressure drop. A pressure drop will occur when there are sharp bends or flow restrictions.

Pressure drop is also a function of air velocity. As the air velocity increases, the pressure needed to move the air increases. Therefore, ducts and plenum should be designed to keep the air velocity between 600 and 1,000 feet per minute. To calculate this velocity, divide the flow rate through the duct (cfm) by the cross sectional area of the duct (ft<sup>2</sup>). This same calculation must be made in the plenum and where the air moves from the plenum to the biofilter material.

Plenums for many biofilters have been constructed out of wood pallets. With these systems the row of pallets next to the barn is raised to allow air to flow parallel to the barn before entering the pallets aligned perpendicular to the barn. Plastic mesh or screen over the pallets prevents the small biofilter particles from falling through the slats. Each row of pallets is laid down, covered with netting, and then covered with media using a TMR wagon before

the next row of pallets is laid down. This reduces the potential for compaction as the media is being placed.

Depending on the pallet construction and mesh or screen used, airflow from the plenum to the biofilter may be restricted, causing excessive pressure drops. Therefore, it is critical to verify that there is adequate open area for air to move from the plenum to the biofilter. Use a criterion of maintaining air velocities between 600 and 1,000 ft/min.

**Organic media.** The biofilter media is a mixture of compost and wood chips at a weight ratio of 40:60 to 20:80. Mixing this material can be done on the ground with a front-end loader or with a TMR mixer. After mixing, the material is placed on the plenum and leveled.

Because compaction of the biofilter media leads to increased pressure drops, it is important to minimize compaction during construction. All ducting work should be done before the media is placed and no machinery or foot traffic should be allowed on the media. Access lanes can be constructed to allow for fan or duct maintenance. If there is a need to walk across the media, it is best to put down planks or sheets of plywood to limit compaction.

It is critical to maintain an even layer of media throughout the biofilter. Air will follow the path of least resistance, which is often the thinnest area of the media. Any channeling of air reduces the biofilter effectiveness. Odorous air may also escape from around the edges of the biofilter media or at the intersection of the ductwork and plenums. Therefore, seal all duct and plenum joints with appropriate caulking or plastic sheeting.

Over time the media will decompose and need to be replaced. Currently there are no requirements for disposal of biofilter media. Some of the media can be mixed with more wood chips and reused in the biofilter. The remaining media should be handled like compost and land-applied to cropland at agronomic rates. If the biofilter media is very dry, there will be significant amounts of dust generated during loading and land application. Avoid breathing this dust.

Fig 6. Odor and H<sub>2</sub>S emissions from a mechanically ventilated swine barn with 31% total ventilation air through pit fans and 69% through wall fan ventilation.

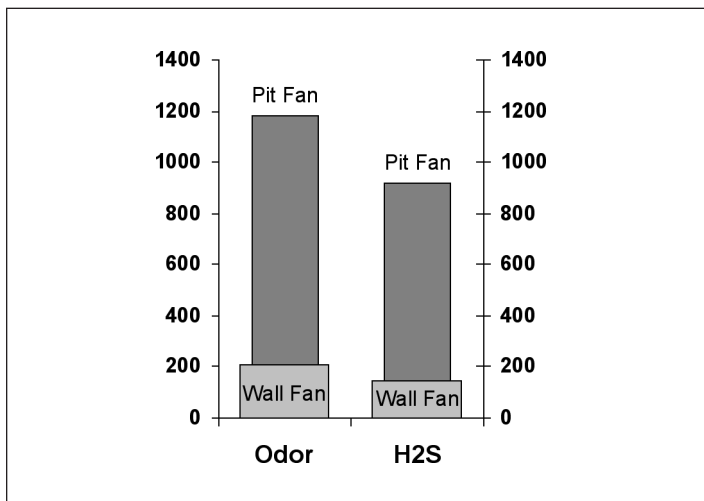
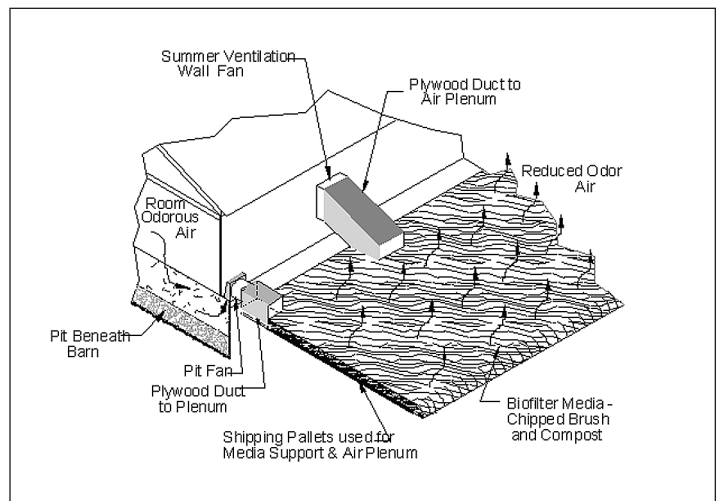

Fig 7. Biofilter construction.





## Biofilter costs

Costs to install a biofilter include the cost of the materials—fans, media, ductwork, plenum—and labor. Typically, cost for new construction on mechanically ventilated buildings will be between \$150 and \$250 per 1,000 cfm.

Annual operation/maintenance of the biofilter is estimated to be \$5-\$10 per 1,000 cfm. This includes the increase in electrical costs to push the air through the biofilter and the cost of replacing the media after 5 years.

Both capital costs and operation and maintenance costs are quite variable. High-cost situations are those where biofilters are retrofit on naturally ventilated buildings to filter air from pit fans or from additionally installed fans for mild weather ventilation.

## Maintenance

Attention is needed in four areas—moisture content, weed control, rodent control, and assessing pressure drop. None of these management issues takes significant amounts of time, but all are important for proper biofilter operation.

**Moisture content.** Biofilter moisture management requires some on-the-job training. Typically, no moisture measurements are needed. Rather, the feel and look of the filter material will be indicators of too much or too little water. During cold weather the media moisture content is fairly constant (from heated exhaust air) and remains at approximately 50%. However, in the summer a media watering system is needed.

A standard lawn sprinkling system is fairly effective. However, because the media dries from the bottom and is watered from the top, it is necessary to dig down into the media to check moisture content. Dampness should be felt one-half to three-quarters of the way down through the depth of the media. If dampness is felt throughout the depth of the media, then the watering system is providing too much water. If, however, only the top few inches are damp then the water needs to be increased. Often, watering is done at night for one or two hours to reduce evaporation losses.

**Weeds.** Weed growth on the biofilter surface can reduce efficiency by causing air channeling and limiting oxygen exchange. Roots can contribute to plugging of biofilter pores. Weeds on a biofilter also reduce the aesthetic appearance of the livestock site. A systemic herbicide or some other means should be used.

**Rodents.** A good rodent control program is essential. Mice and rats burrow through the warm media during the cold winter months, causing channeling and poor treatment. Rabbits, woodchucks, and badgers have been suspected of burrowing through and nesting in biofilters. Fortunately, most livestock and poultry operations currently have a good rodent control program. These programs are not very expensive.

**Assessment of pressure drop.** Over time the degradation of the media material, dust buildup in the media, and media settling will cause the pressure drop across the media to increase. As pressure drop increases the amount of air moved by the ventilation fans decreases, eventually resulting in poor building ventilation. The type of biofilter media and the dustiness of the exhaust air will both affect the length of time before the media plugs and the pressure drops become excessive.

Unfortunately, no long-term studies have been conducted to determine just how long this will take, but it is estimated that most biofilters will last 5 to 8 years or more. Poor building ventilation at maximum ventilation rates will likely be the first sign of biofilter plugging. A manometer can be used to check the pressure drop across the biofilter. Depending on the design of the biofilter and ventilation fans, pressure drops over 50% of the design pressure drop indicate the need to replace the media. Note that the maximum pressure drop must be measured at maximum ventilation rates.

## Health and safety concerns

There is little research information on the potential health implications of microbial emissions from biofilters. In one study, the concentrations were only slightly more than ambient outdoor air. In a laboratory study, relatively large numbers of spores were released during the initial startup but the numbers quickly diminished and stabilized. Dust and bioaerosols from biofilters are not expected to be a problem during normal operation. Dust and mold spore emissions during construction, maintenance, and removal may pose a potential health risk. Dust control and personal protection (dust filter masks) may be useful to minimize exposure.

## References

- Janni, K.A., W.J. Maie, T.H. Kuehn, B.B. Bridges, D. Vesley, M.A. Nellis. 1996. Evaluation of biofiltration of air, an innovative air pollution control technology. MWPS-32. 1990. Mechanical ventilating systems for livestock housing. Ames, Iowa: MidWest Plan Service.
- Nicolai, R.E., K.A. Janni. 1997. Development of a low cost biofilter on swine production facilities. ASAE Paper 97-4040.
- Noren, O. 1985. Design and use of biofilters for livestock buildings. Pp 234-237 in Odour prevention and control of organic sludge and livestock farming (V.C. Nielsen, J.H. Voorburg, P.L. L'Hermite, eds). New York: Elsevier Applied Science Publishers.
- Zeisig, H.D., T.U. Munchen. 1987. Experiences with the use of biofilters to remove odours from piggeries and hen houses. Pp 209-216 in Volatile emissions from livestock farming and sewage operations (V.C. Nielsen, J.H. Voorburg, P.L. L'Hermite, eds). New York: Elsevier Applied Science Publishers.