

South Dakota State University  
**Open PRAIRIE: Open Public Research Access Institutional  
Repository and Information Exchange**

---

Animal Health MATTERS Newsletter

Veterinary and Biomedical Sciences

---

10-2015

## Animal Health MATTERS

Russ Daly  
*South Dakota State University*

Jane Christopher-Hennings  
*South Dakota State University, jane.hennings@sdstate.edu*

Christopher C.L. Chase  
*South Dakota State University, christopher.chase@sdstate.edu*

Follow this and additional works at: [http://openprairie.sdstate.edu/vbs\\_news](http://openprairie.sdstate.edu/vbs_news)



Part of the [Veterinary Medicine Commons](#)

---

### Recommended Citation

Daly, Russ; Christopher-Hennings, Jane; and Chase, Christopher C.L., "Animal Health MATTERS" (2015). *Animal Health MATTERS Newsletter*. Paper 32.  
[http://openprairie.sdstate.edu/vbs\\_news/32](http://openprairie.sdstate.edu/vbs_news/32)

This Newsletter is brought to you for free and open access by the Veterinary and Biomedical Sciences at Open PRAIRIE: Open Public Research Access Institutional Repository and Information Exchange. It has been accepted for inclusion in Animal Health MATTERS Newsletter by an authorized administrator of Open PRAIRIE: Open Public Research Access Institutional Repository and Information Exchange. For more information, please contact [michael.biondo@sdstate.edu](mailto:michael.biondo@sdstate.edu).

***Advisory Committee***

***Colorado State University Students***

•

•

•

•

■

## Infectious Bovine Rhinotracheitis Diagnostics: Is it a Field Strain or a Vaccine Strain?

Russ Daly and Chris Chase, SDSU

Infectious bovine rhinotracheitis (IBR) virus, a virus that we usually think of as only being associated with shipping fever and pneumonia, can have a very potent effect on the reproductive tract and reproductive organs. This is true both for field strains and strains found in IM and SC vaccines. IBR virus is a herpesvirus (bovine herpesvirus 1, BHV-1) closely related to two other animal herpesviruses: pseudorabies virus of swine and equine herpesvirus of horses. These three viruses all cause severe reproductive disease, including abortion, as well as respiratory disease. These effects are in contrast to herpes simplex virus of people that causes genital herpes, a localized infection.

### How does IBR virus affect reproduction?

Certain strains of IBR can cause localized genital infections in both bulls and cows (1) similar to genital herpes in people. The difference is that in cattle, these lesions are not recurrent in nature. A more important effect on reproduction occurs when the IBR virus enters the bloodstream of the cow following infection. IBR infections that manifest themselves as oral or upper respiratory infections may or may not be characterized by viral entry into the bloodstream. Parenteral vaccines containing live IBR virus always present the possibility for the virus to enter the bloodstream (and subsequently the ovary and uterus). In IBR-vaccinated animals, the animal's previous immunity usually prevents this from happening.

Once in the bloodstream, the IBR virus can travel to and infect reproductive organs, particularly the ovary. The ovary is a major target for the virus, which can adversely affect the corpus luteum as well as the developing follicles. In a normal bovine reproductive cycle, the ovary will undergo two follicular waves where a primary follicle will develop in each wave. In the first wave, the primary follicle regresses, but after the second wave the primary follicle matures, resulting in the release of an egg. This second follicle then becomes the corpus luteum. The corpus luteum (or CL) is essential for the early maintenance of pregnancy. IBRV can cause necrosis of the CL, thereby

short-circuiting the cycle in a non-pregnant animal, and causing early embryonic death in a newly-pregnant animal, since the CL is no longer viable to maintain the pregnancy. In addition, IBRV can infect the fetus directly and cause abortion.

### IBR Vaccines, Abortions and Detecting Vaccine Strains

Four vaccine manufacturers in the United States currently sell multivalent vaccines containing modified live IBR virus that are labeled for use in pregnant cattle. These labels allow these products to be used year-round, in various stages of pregnancy, resulting in an increase in their use. A major disadvantage of such use, however, is that they can cause pregnancies to be aborted unless vaccination has been done within the previous 12

months using the specific vaccine product in strict accordance with label directions. In addition, it has become clear that even used in accordance with label directions can result in abortions (2).

It is impossible to distinguish iatrogenic abortions (caused by the administration of MLV vaccine) from natural abortions on the basis of lesions and virus isolation alone. Use of single nucleotide polymorphisms (SNPs) in the genetic material of BoHV-1 strains was proposed as a method to resolve whether outbreaks were likely to be iatrogenic (3). The fact that IBR is a stable DNA virus makes these SNP procedures possible. To determine the SNP pattern of a virus, the entire virus' DNA is sequenced and then the vaccine viruses matched up with a "known" laboratory virus. The sequences are then compared and SNPs are identified (Figure 1). Using this information, 3 different segments are compared and individual SNPs are identified. The unknown is then compared to the known SNP for the IBR vaccine viruses. The SDSU ADRDL has the capability to run this procedure on either virus isolates or infected tissues (either placenta or fetus).

We have investigated 15 abortion episodes (10 from Wyoming, 2 from North Dakota, 2 from Minnesota and 1 from Indiana) between 2010–2015 yielding virus isolates where an apparent association existed between use of modified live IBR vaccine and abortion over the subsequent 1–8 months. For each individual episode, the products were either used "on" or "off" label according to the producer. All 15 isolates had SNP patterns consistent with those of commonly used modified live IBR vaccine strains. Use of SNP patterns has proven helpful in resolving whether abortion was likely due to "vaccinal virus," particularly when disagreement existed between a producer and representatives of the vaccine manufacturer.

The SDSU ADRDL is running this service as an aid in investigating IBR abortion cases. Fetal tissue and placenta is used, and PCR testing can be performed on these samples without isolation of the virus. The charge for sequencing is \$300. For questions regarding applying this service to diagnostic cases, contact Travis Clement at the SDSU ADRDL at 605-688-5171.

Figure 1

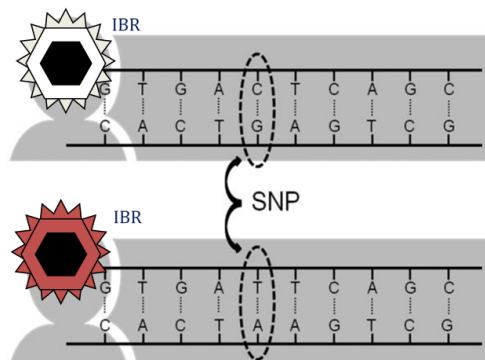

months using the specific vaccine product in strict accordance with label directions. In addition, it has become clear that even used in accordance with label directions can result in abortions (2).

It is impossible to distinguish iatrogenic abortions (caused by the administration of MLV vaccine) from natural abortions on the basis of lesions and virus isolation alone. Use of single nucleotide polymorphisms (SNPs) in the genetic material of BoHV-1 strains was proposed as a method to resolve whether outbreaks were likely to be iatrogenic (3). The fact that IBR is a stable DNA virus makes these SNP procedures possible. To determine the SNP pattern of a virus, the entire virus' DNA is sequenced and then the vaccine viruses matched up with a "known" laboratory virus. The sequences are then compared and SNPs are identified

## SDSU's Food Safety Microbiology Section: Serving Locally and Recognized Nationally

Russ Daly DVM, SDSU

The role of SDSU's ADRDL in protecting animal health through timely and accurate diagnosis of animal diseases is well-known. But its role also extends to protecting human health by testing foodstuffs for harmful pathogens that may be harbored in those foods.

Established in 1999, the ADRDL Food Safety Microbiology (FSM) Laboratory section screens samples of ground beef, ready-to-eat meats, carcass swabs, and food contact surface swabs from 49 small meat production lockers and slaughter houses in South Dakota, North Dakota and Vermont. These samples are analyzed for the presence of a number of pathogens, such as *Salmonella*, *Campylobacter*, *Listeria monocytogenes*, and *Escherichia coli* O157:H7. The FSM Lab also has the capability to screen a large number of other types of samples (Dairy, Canned Foods, Environmental Samples, etc.) for common food-borne pathogens, toxins and indicator organisms (e.g Staph enterotoxin, Aerobic Plate Counts, Coliform Counts) upon special request. In addition to the regulatory inspection activity it performs, the FSM Lab has provided food testing for many custom designed research projects along with routine surveillance programs.

The FSM section provides services for the South Dakota Animal Industry Board Meat Inspection Program, the North Dakota Meat and Poultry Inspection Program, the Vermont Agency of Agricul-

ture, Food and Markets, the South Dakota State Canned Food Processing Authority, along with many local food producers and processors. While regulatory customers are the primary end user of the lab, the FSM services are available to all area food providers and residents. In fiscal year 2014, the Food Safety Section tested 1,609 different sam-

ples for a variety of foodborne pathogens.

In 2004, the ADRDL joined the Food Emergency Response Network (FERN). The FERN integrates the nation's food-testing laboratories at the local, state, and federal levels into a network that is able to respond to emergencies involving food contamination. Its structure is organized to take advantage of inter-agency cooperation on local, state, and federal levels.

The SDSU ADRDL is one of 170 FERN labs across the country and one of only 24 veterinary diagnostic labs in the network. The quality of work put out by SDSU's FSM laboratory is exemplified by the recent news that SDSU's ADRDL was chosen as one of only 20 FERN laboratories to receive a third round of 5-year funding through the program. SDSU was the only strictly veterinary lab chosen for this distinction.

Membership in the FERN has been a great asset to SDSU's ADRDL, allowing multiple staff members the opportunity to become trained in a wide variety of

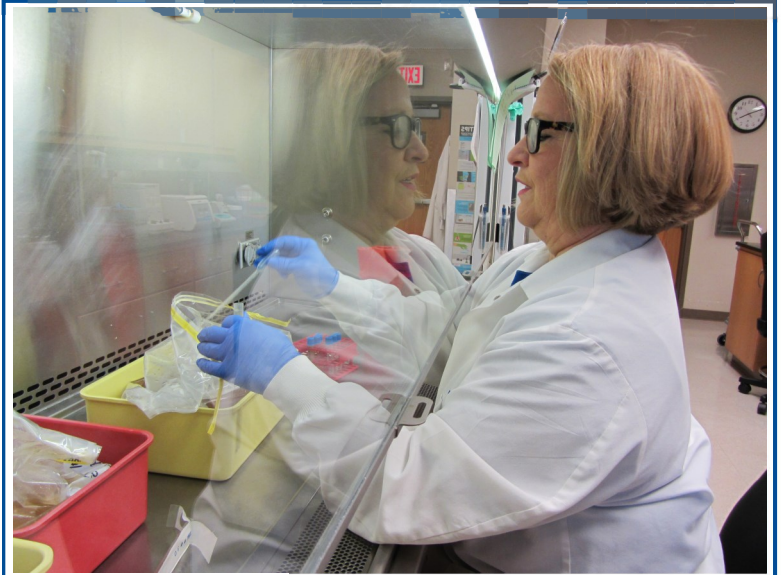

Deb Murray, ADRDL Food Safety Section Senior Microbiologist, aliquots out a sample from breakfast sausage that has been incubating overnight in 3 liters of enrichment broth. The 5 ml aliquot will be tested for salmonella and listeria using PCR technology.

diagnostic techniques. Perhaps the most advantageous feature of the FERN is in the connections to other food testing laboratories across the country, connections that have paid off when the ADRDL considers new methods or techniques. An example of that collaboration that happens to occur right in the same building is that of the support that the FSM lab offers to the VET LiRN Program in which SDSU also participates. The VET-LiRN is a network of government and veterinary diagnostic laboratories set up to respond to high priority chemical and microbial contamination events in feeds or medications.

The FSM section collaborates regularly with other SDSU departments and SDSU Extension on issues surrounding food safety. Safe preparation of food at farmer's markets is an example of a fruitful collaboration with interested parties across the state. Recent changes to laws within the state of South Dakota allow small producers to prepare particular products for sale within their home kitchen as opposed to a commercial kitchen. The primary requirement is a process certification that requires microbiology

As part of FERN, the Food Safety Microbiology section has been involved in many multi-lab validations, training courses, surveillance activities, and proficiency tests, including:

- Detection of Staphylococcal enterotoxin in meats
- Comparison of methods to detect *E. coli* O157:H7 and other shiga toxin-producing *E. coli* strains
- Detection of *Shigella*, *Bacillus anthracis*, and *Clostridium botulinum* neurotoxin
- Detection of *Francisella tularensis*, *Brucella*, and rotavirus in foods using Real-time PCR
- Use of MALDI-TOF Mass Spectrometry for screening of food products for toxins/pathogens



testing, which is performed at the FSM lab in conjunction with the South Dakota Canned Food Processing Authority.

The capacity and efficiency of the FSM section has been greatly enhanced with their recent move into a former pathology research laboratory within the ADRDL building. This new location allows for better assurance of sample integrity and chain of custody procedures to be followed. Due to this positive change, the FSM Lab is in the process of ISO 17025 Accreditation. This stricter level of accreditation is test based, opposed to the lab-wide AAVLD accreditation currently in place at the ADRDL. The FDA and USDA/FSIS laboratory systems have recently suggested that participating laboratories undergo this rigorous test certification process and the ADRDL FSM Lab is putting some exciting new tools in place to aid with implementation of these new stricter requirements, including remote temperature monitoring systems and quality document management soft-

ware.

The ADRDL Food Safety Microbiology (FSM) section is comprised of analysts who possess a broad scientific background:

**Alan Erickson** is the FSM laboratory section leader, having taken over that role in 2013. Dr. Erickson is a protein biochemist that has been a teacher and researcher in the Veterinary and Biomedical Sciences Department for 25 years. His previous research experience with *E. coli* pathogenesis and a wide variety of analytical techniques should help integrate food safety research and diagnostics within the FSM.

**Laura Ruesch** is the FSM laboratory section manager and FERN CAP project director, with 13 years of experience in food microbiology, primarily in molecular detection methods. Laura obtained her MS in Food Safety from Michigan State University and a BS in Microbiology/Biology from SDSU. She functions as the Project Manager for the FERN Coop-

erative Agreement and Case Coordinator for the Food Safety section.

Senior Microbiologist **Deb Murray**, CLT, rounds out the staff. Deb has 20 years of experience at the ADRDL, having recently moved from the bacteriology section. She performs the daily testing and fields most customer requests. ■

## Colorado State University Students

*(Continued from page 1)*

their interest in spending time at SDSU, Goldsmith stated, “There is much more of a food animal caseload here at SDSU’s veterinary diagnostic lab compared to our lab at CSU. I wanted to get a chance to see a diverse range of animals and conditions as I decide whether to pursue further education in veterinary pathology.” Taylor echoed those comments. “It was especially interesting to become exposed to swine medicine and diseases, as we do not see those cases at CSU. This has been a valuable experience in getting a baseline regarding the breadth of pathologic conditions across species,” she said.

Diagnostic laboratories at many veterinary schools are attached to teaching hospitals. Therefore, most of the casework comes from equine and companion animals. “Our experience at SDSU was interesting in that we got to see much more infectious disease-related conditions, while we would see more chronic and neoplastic (cancer) conditions back home,” according to Taylor.

While the ADRDL and the Veterinary and Biomedical Sciences Department do not currently offer a residency in veterinary pathology, the faculty and staff are very accommodating to students for more informal training opportunities. Dr. Angela Pillatzki, who coordinated the CSU students’ visit, said, “The ADRDL can provide an enriching experience for veterinary students and pathology residents because our caseload is species-diverse, but focused on food animals; diagnosing infectious disease is our main discipline. Additionally, our faculty and staff are experienced and knowledgeable, and can help students better understand the testing processes and procedures which embody veterinary diagnostics.” These opportunities are just some of the examples of the ways the ADRDL helps inform the next generation of veterinary and biomedical scientists. ■

## Advisory Committee

*(Continued from page 1)*

group and the ADRDL. Many have served long terms as Committee members and enjoy that particular role. Glenn Muller, Executive Director of the South Dakota Pork Producers Council, is one of those members. “Pork producers depend on the professional and timely diagnosis of swine diseases provided by the ADRDL along with the research and technology that is being generated by the laboratory. With the emergence of Porcine Epidemic Diarrhea virus (PEDV), the laboratory not only was able to make

the prompt and proper diagnosis of the virus but also developed new techniques to allow for a more rapid diagnosis allowing producers to move into the treatment stage sooner, minimizing the effects of this new disease,” he said. “The dedication and expertise of the staff of South Dakota’s ADRDL is appreciated and recognized as being a vital factor in addressing the health of the swine herd in South Dakota and beyond our borders.”

Current ADRDL Advisory Committee members include:

Name	Association	Hometown
Lewis Bainbridge	Farmer/Producer	Ethan
Dr. Russ Daly	SDSU Faculty Representative	Brookings
Rufus DeZeeuw	SD Sheep Growers	Elkton
Bob Hutchinson	SD Stockgrowers	White River
Dr. Jill Hyland Ayres	SDVMA Companion Animal Rep.	Brookings
Ralph Jones	Rancher/Producer	Midland
Tom Kirschenmann	SD Game, Fish, and Parks	Pierre
Dr. Kevin Klozenbucher	SDVMA Legislative Committee	Huron
Glenn Muller	SD Pork Producers Council	Sioux Falls
Greg Ode	SD Federation of Dairy Farmers	Brandon
Dr. Dustin Oedekoven	SD State Veterinarian	Pierre
Dr. Steve Smith	SDVMA	Groton
Jennifer Stalley	SDVMA Executive Secretary	Pierre
Dr. Tom Stenberg	SD Cattlemen’s Association	Volga
Dr. Christy Teets	SDVMA President	Rapid City
Dr. Dave Zeman	SD Poultry Industries Assn.	Brookings

## Pieces and Parts

### Veterinarian/SDSU Alum Serving as SDSU Livestock Environment Extension Associate

Dr. Joe Darrington joined SDSU Extension this past summer as a Livestock Environment Extension Associate in the Agriculture and Biosystems Engineering Department. A native of Brookings, Dr. Darrington graduated from SDSU with a degree in Agricultural Engineering in 2011 before going on to veterinary school at Iowa State University. Joe completed his DVM degree in 2015 and is finishing an MPH degree from the University of Iowa.

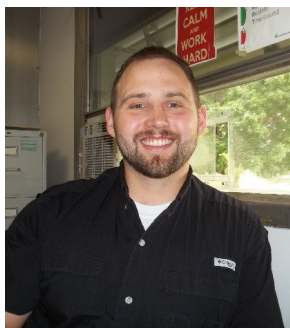

SDSU Extension Livestock Environment Associate  
Joe Darrington, DVM

In his position, Dr. Darrington works with individuals on animal facility site layout, ventilation, and structural concerns. His veterinary training helps him especially focus on the relationship between man-made animal environments and animal health. "I enjoy talking to producers about their management philosophy and goals of production the most. It is especially fun to talk through options in the built environment that could significantly affect disease prevalence and risk. These factors might include ventilation, stocking rates, and biosecurity."

Dr. Darrington welcomes interaction with veterinarians and producers in formulating solutions and designs for animal facilities with health and biosecurity in mind. "The veterinary community is the frontline concerning health issues and trends in the state," he says. "I am available to both producers and veterinary colleagues to work through ideas to modify the built environment to maximize animal health and limit risks. We have an opportunity to significantly impact producers in the state by working together with veterinarians and producers through meetings and problem solving." He is excited to be back in his home state and to utilize all aspects of his education in his new role.

You can reach Dr. Darrington at 605-688-5672 or [jo-seph.darrington@sdstate.edu](mailto:jo-seph.darrington@sdstate.edu).

### New Hire in Media Preparation: Suman Rohila

Suman Rohila started her position in the Media Preparation/Kitchen section on August 24. In her position she prepares media and solutions for the other ADRDL sections' use. She has an academic degree in nematology, and has extensive laboratory experience from previous positions at Cornell University, Penn State, and SDSU. Previously, she served as a laboratory manager in the Biology/Microbiology Department at SDSU. Her extensive experience allows her to assist in the bacteriology and food safety sections when circumstances warrant. Suman lives in Brookings with her husband Jai, an Assistant Professor in Bio/Micro at SDSU and children Aarushi and Nikita.



### New Hire in Molecular Diagnostics: Melissa Lorenzen

The ADRDL welcomed Microbiologist Melissa Lorenzen to full-time status in the Molecular Diagnostics section this past August. Melissa began her employment in the section as a part-time worker following her Spring 2015 graduation from SDSU with a degree in Medical Laboratory Sciences. A native of Castlewood, Melissa is responsible for Porcine Epidemic Diarrhea Virus testing within the section, among many other responsibilities. She lives in Brandt with her husband Zach.

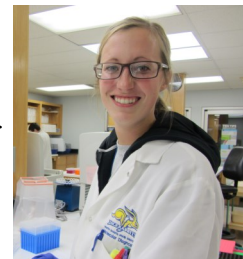

### Daly Joins US Contingent on Visit to Chinese Veterinary Research Institute

This past summer, Extension Veterinarian Russ Daly joined five colleagues from Mississippi State University and North Dakota State University on a two-week trip to China to investigate providing educational opportunities in veterinary epidemiology.

The trip was made possible through a USDA Foreign Agricultural Services US-China Scientific Cooperation Exchange Program award. The overall goal of the visit was for the team to exchange ideas on developing a comprehensive Field Epidemiology Training Program for Veterinarians (FETPV). Objectives underneath that goal included:

- 1) Exchange information on the epidemiology of major livestock diseases and infections of concern to public health, food security, and food safety in both the US and China;
- 2) Understand the population-based systems for controlling disease and impaired productivity in the US and China;
- 3) Identify educational needs for veterinary epidemiologists, and other stakeholders including graduate veterinarians, veterinary students, livestock producers, and other decision-makers; and
- 4) Develop a plan for delivering world-class training in epidemiological methods, including population medicine concepts, biostatistics, data storage, data analysis, risk assessment, and system dynamics modeling.

The team was hosted by representatives from the Chinese Ministry of Agriculture. The visits concentrated on research institutes underneath the umbrella of the Chinese Academy of Agricultural Sciences (CAAS). These institutes, located across China, employ researchers in various fields of veterinary medicine, including virology, bacteriology, parasitology, immunology, and vaccine development, among others.

Research institutes in Beijing, Lanzhou, Harbin, and Shanghai were visited, as well as USDA personnel at the US Embassy and FAO staff in Beijing. At each stop, team members gave presentations on epidemiologic methods in the US and afterwards engaged in discussions centered on providing epidemiology training for veterinary researchers and students. At the Harbin Veterinary Research Institute, Dr. Daly presented a talk on "Veterinarians, Public Health, and Epidemiology in the US."

Other veterinarians on the trip included Drs. David Smith, Bob Wills, and Margaret Khaita, as well as Henry Wan, PhD, from Mississippi State University and Dr. Charlie Stoltenow, North Dakota State University. ■



## South Dakota One Health Meeting on Influenza Draws Diverse Audience

Dr. Russ Daly, SDSU

“Human Influenza, Animal Influenza, and their Interactions” was the title of the latest effort to bring together human health and animal health interests from across South Dakota. Co-sponsored by SDSU Extension, the SD Animal Industry Board, SD Department of Health, and USD Sanford School of Medicine, this latest South Dakota One Health meeting was held September 24 at the USD Sanford School of Medicine in Sioux Falls.

Over 80 people from a diverse set of backgrounds attended the educational event. Physicians, nurses, medical students, researchers, teachers, government agency representatives, veterinarians, and animal producers were among the different attendees. Thirteen different presentations included talks on human influenza epidemiology, diagnostics, patient management, and prevention. These subjects alternated with presentations on the avian influenza outbreak, influenza in South Dakota wildlife, swine influenza, and instances of zoonotic influenza.

Attendees heard personal accounts of the avian influenza outbreak of this past spring. Ruben Waldner from Riverside Colony related their experiences that saw the deaths of 65,000 turkeys through the effects of the virus and preemptive culling. Jason Ramsdell, Dakota Layers, was on hand to discuss the devastation that

the infection had on their over 1.2 million layer hens, as well as their employees and their families. Dr. Ben Wileman, a South Dakota native and veterinarian from Ag Forte in Willmar, Minn., gave an overview of the outbreak across the Upper Midwest and lessons learned.

South Dakota Area Health Education Center provided a noon meal and facilitated discussions regarding future “One Health” education efforts in South Dakota. Comments from attendees indicated the meeting accomplished its goal of networking between individuals working in human and animal health. “I enjoyed being able to communicate with both veterinarians and health professionals,” wrote a health sciences faculty member. A government agency staff member wrote, “This type of program provides tremendous value to promote the animal/human health connection. Please continue again next year!”

This meeting was the seventh of its kind, dating back to 2011. Previous topics included rabies, Q Fever, tuberculosis, animal contact zoonoses, and antibiotic resistance and use. Plans are underway to set the next agenda topic and date. ■

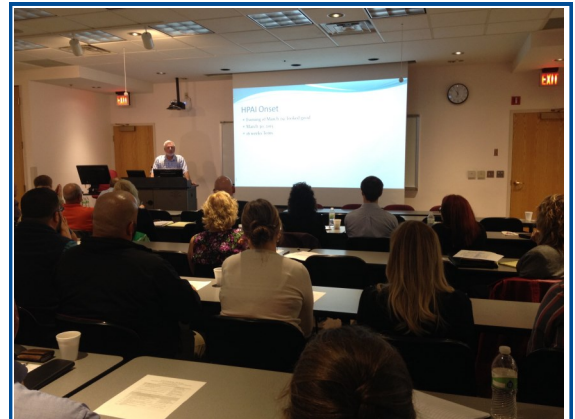

Ruben Waldner, Riverside Colony, relates their experiences with avian influenza to attendees at the South Dakota One Health meeting on influenza, September 24, 2015, in Sioux Falls.

## VBS Researchers Seek to Understand Salmonella Persistence in Fed Cattle

Researchers in the SDSU Departments of Veterinary and Biomedical Sciences and Animal Science have joined forces to identify factors related to the persistence of Salmonella in fed cattle.

Salmonella, an important food safety concern, arises from subclinically, persistently colonized animals. Evidence suggests this contamination occurs from Salmonella migrating to lymph nodes, which are incorporated into ground beef and other meat products.

This project will utilize whole genome sequencing to help identify the factors that allow Salmonella to colonize the animals and migrate to lymph nodes, in addition to examining the role of the gut microbiome in this process. Researchers also will investigate breed susceptibility to *Salmonella* infection.

### No-cost Salmonella testing available to participating veterinarians

Veterinarians are invited to submit fecal samples for *Salmonella* testing and sequencing, at no cost. Eligible animals include weaned animals raised for beef; they may be clinical *Salmonella* suspects or healthy-appearing. Samples should be rectal swabs (2 per animal) or fecal samples. Swabs should be submitted in appropriate transport media in individual containers. Package for shipping as per usual. Fill out the regular ADRDL General Submission form and indicate “SDSU Salmonella Study” on the form. Results will be reported back as with a typical submission. *Salmonella* culturing and sequencing is free, but regular charges apply if other tests are requested.

Please contact Dr. Joy Scaria at 605-688-5171 if you have questions, or would like to obtain swabs and transport media.

## Seneca Valley Virus Noted in South Dakota, ADRDL Diagnostics in Place

Seneca Valley Virus, a novel virus affecting pigs, has been diagnosed in South Dakota swine herds. As a result, the ADRDL has implemented a real-time PCR test for this virus. The virus has been associated with vesicular lesions, or blisters, on the pigs’ snout and feet. These signs are quite indistinguishable from other vesicular foreign animal diseases, and need to be investigated as such.

In addition to the vesicular lesions noted in affected pigs, an increase in finisher pig lameness and baby pig mortality have also been associated with Seneca Valley Virus. Swine producers suspecting Seneca Valley Virus in their herds, or notice vesicular lesions, should first contact the South Dakota State Veterinarian’s office at 605-773-3321. Sampling strategies can then be coordinated for rapid identification. Desired samples are fluid from vesicles, swabs from erupted vesicles, or skin scrapings from around lesions.

For more information on Seneca Valley Virus, please see: <http://www.swinehealth.org/emerging-disease-information/>. ■

Printed by the Veterinary and Biomedical Sciences Department, South Dakota State University, Jane Hennings, Head/Director, VBSD/ADRDL. South Dakota State University, South Dakota counties, and USDA cooperating. SDSU adheres to AA/EEO guidelines in offering educational programs and services. 905 printed at a cost of .63 each



**SOUTH DAKOTA STATE UNIVERSITY**  
**SDSU Veterinary and Biomedical Sciences Department**  
**Animal Disease Research & Diagnostic Laboratory**  
**Box 2175- North Campus Drive**  
 Brookings, SD 57007-1396  
 Phone: (605) 688-5171  
 Fax: (605) 688-6003  
 Website: [www.sdstate.edu/vs](http://www.sdstate.edu/vs)

Non-Profit Org.  
 U.S. Postage  
**PAID**  
 Brookings, SD  
 Permit 24

The SDSU Veterinary and Biomedical Sciences Department conducts research, teaching, professional service, and extension service to South Dakota and the surrounding region. An entity within the SDSU Veterinary and Biomedical Sciences Department, the South Dakota Animal Disease Research and Diagnostic Laboratory is a full-service, all-species diagnostic laboratory accredited by the American Association of Veterinary Laboratory Diagnosticians (AAVLD). The AAVLD accreditation program complies with international expectations for quality diagnostic services under the guidance of the World Organization for Animal Health (the OIE). The ADRDL collaborates with the USDA National Veterinary Services Laboratory on many federal disease monitoring and eradication programs and is a member of the National Animal Health Laboratory Network. For information regarding the laboratory's Quality System, contact Rajesh Parmar – ADRDL Quality Manager, at 605 688 4309.

## Animal Health MATTERS

### Continuing Education Events

**November 5-6, 2015**  
**ISU James D. McKean Swine Disease Conference,**  
 Ames, IA. <http://www.extension.iastate.edu/registration/events/conferences/swine/index.html>

**December 3-5, 2015**  
**Academy of Veterinary Consultants Winter Meeting,**  
 Embassy Suites International Airport Hotel, Kansas City, MO, [www.avc-beef.org](http://www.avc-beef.org)

**December 5-9, 2015**  
**American Association of Equine Practitioners Annual Convention,** Las Vegas, NV  
<http://www.aep.org/info/annual-convention>

**February 13, 2016—James Bailey Herd Health Conference, Brookings, SD,** Virginia Fajt from Texas A&M will talk on practical uses of antibiotics in food animals (605) 688-6649 or [www.sdvmed.org](http://www.sdvmed.org)

Editor: Russ Daly, DVM

### IN THIS ISSUE

Advisory Committee Provides Big-Picture Guidance to the ADRDL.....	1
Colorado State University Vet Students get Food Animal Experience at SDSU's ADRDL.....	1
Director's Message.....	2
Infectious Bovine Rhinotracheitis Diagnostics: Is it a Field Strain or a Vaccine Strain?.....	3
SDSU's Food Safety Microbiology Section: Serving Locally and Recognized Nationally .....	4
Pieces and Parts Veterinarian/SDSU Alum Serving as SDSU Livestock Environment Extension Associate .....	6
New Hire in Media Preparation: Suman Rohila.....	6
New Hire in Molecular Diagnostics: Melissa Lorenzen .....	6
Daly Joins US Contingent on Visit to Chinese Veterinary Research Institute.....	6
South Dakota One Health Meeting on Influenza Draws Diverse Audience .....	7
VBS Researchers Seek to Understand Salmonella Persistence in Fed Cattle .....	7
Seneca Valley Virus Noted in South Dakota, ADRDL Diagnostics in Place.....	7
<b>Continuing Education Events.....</b>	<b>8</b>