

South Dakota State University
**Open PRAIRIE: Open Public Research Access Institutional
Repository and Information Exchange**

Bulletins

South Dakota State University Agricultural
Experiment Station

7-1-1961

Low Voltage Flexible Sequence Automatic Controls

M. D. Paine

H. Winterfeld

D. L. Moe

Follow this and additional works at: http://openprairie.sdstate.edu/agexperimentsta_bulletins

Recommended Citation

Paine, M. D.; Winterfeld, H.; and Moe, D. L., "Low Voltage Flexible Sequence Automatic Controls" (1961). *Bulletins*. Paper 500.
http://openprairie.sdstate.edu/agexperimentsta_bulletins/500

This Bulletin is brought to you for free and open access by the South Dakota State University Agricultural Experiment Station at Open PRAIRIE: Open Public Research Access Institutional Repository and Information Exchange. It has been accepted for inclusion in Bulletins by an authorized administrator of Open PRAIRIE: Open Public Research Access Institutional Repository and Information Exchange. For more information, please contact michael.biondo@sdstate.edu.

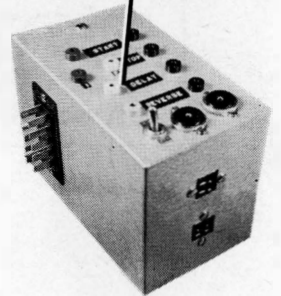
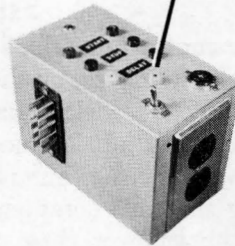
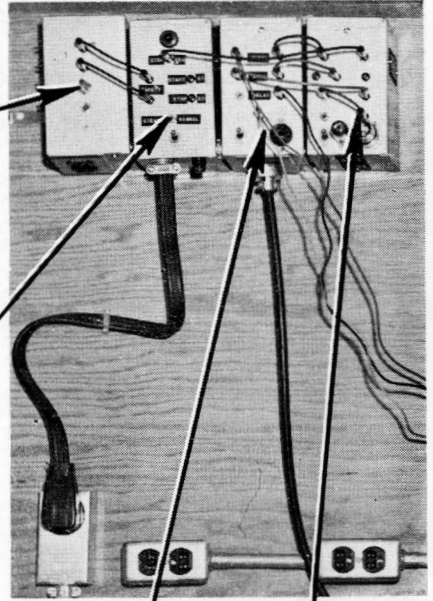
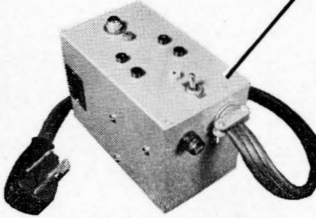
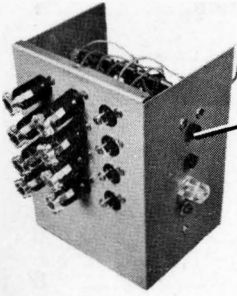

**LOW VOLTAGE
FLEXIBLE
SEQUENCE CONTROLS**

Contents

Functional Requirements of Controls for Farm Automation.....	4
Start and Stop Sequence.....	4
Flexible Connections	6
Delays	6
Low Voltage	6
Unitization.....	6
Equipment Protection	6
Design of Controls for Farm Automation.....	7
Parts List	18

SUMMARY

The controls described in this bulletin meet the functional demands of automation on the farm—"stop" and "start" sequence, flexible connections, delays, low voltage signalling, unitization, and equipment protection. In meeting the functional demands, these controls overcome the limitations of custom designed control circuits using standard components. Also by allowing use of hours instead of horsepower, these controls normally permit installation of an automatic feeding system at a lower cost than comparable push button mechanized systems.

This low voltage, flexible sequence control system is composed of power relay units, a master unit, a systems protection unit, and, in special instances, a reversing motor unit. The circuitry for the four basic units of this control system is explained in detail and shown in the schematics and photographs.

Low Voltage Flexible Sequence Automatic Controls

By MYRON D. PAINE, HAROLD WINTERFELD, and DENNIS L. MOE

There is a great deal of interest in making the chore of feeding livestock easier. Some farmers have installed equipment that has mechanized their feeding operation. Many other farmers are planning to do the same, but are still looking for a better solution to their particular feeding problem.

When farmers consider mechanization there is a tendency to use high speed, large capacity equipment. This tendency is the result of farmers being accustomed to the speed and capacity of machinery used in the field. Field machinery must do a lot of work as rapidly as possible because the farmer must be time conscious to successfully plant, cultivate, and harvest crops at the proper time.

High capacity is an advantage for field equipment but is not required for feeding equipment. Equipment for feeding systems can be of relatively small capacity and take a long period of time to do its job because it is not drastically limited by weather and seasons. However, high capacity, high-cost equipment is often used simply because of the limited time that the farmer can afford to spend starting, waiting for, and stopping the equipment, two or more times a day.

There is another approach to mechanization. This approach is to use controls to automatically start and/or stop the feeding equipment.

The major advantage of this approach is that the operator does not have to wait for the equipment to accomplish its task. Therefore, smaller, lower capacity, lower cost equipment can be used. Because of this, automatic feeding systems can normally be installed for less cost than a comparable push button system. With automation (automatically-controlled mechanization) the farmer's presence is not required to operate the equipment. He can use his time to inspect the livestock, or for some other useful purpose.

To make a mechanized system fully automatic, the entire arrangement is dependent on the controls to operate it. At present, the controls available have certain limitations, which are listed below:

1. Farmers, county agents, and other agricultural consultants usually do not have the training to design control systems using a combination of standard relays, timers, and other control equipment.
2. Every mechanized feeding system is a unique control problem. Even with skilled, imaginative engineering, control designing takes too much time to be practical for every farm.

Mr. Paine is assistant professor in agricultural engineering, Mr. Winterfeld is assistant agricultural engineer, and Mr. Moe is head of the department of agricultural engineering.

3. After a circuit is specially designed, the control system must be assembled by a skilled electrician.
4. Even when assembled, the specially designed and built control system is experimental until the "bugs" have been eliminated.
5. Once finally installed, the system is permanent and can be altered only by the engineer and skilled electricians.
6. The system also requires skilled maintenance.
7. There is the safety problem, especially with the switch installations at the bunks and other outdoor locations.

This bulletin is a report on the development of a control system designed to aid in overcoming the above limitations of controls for farm automation.

Functional Requirements of Controls for Farm Automation

Controls for farmstead automation of completely mechanized feeding systems should be adapted to the tasks they have to perform. In addition, there are several desirable features that could be incorporated for convenience. A listing of the functions that the controls have to perform and other features that are desirable follows.

START AND STOP SEQUENCE

Farmstead feeding systems involve a combination of five basic functions: storage, blending, processing, conveying, and feeding. As a typical example, consider the feeding system in figure 1. Here are the functions of storage (two holding bins), blending (auger and supplement meter), processing (grinder), conveying (auger to feeder), and finally, feeding (self feeder).

The main control problem is to start and stop the equipment to per-

form these functions at the proper time. In reality, the control process can be broken down into two separate sequences. There is the "starting sequence" when the equipment should be started in the proper order. For example, the conveyor auger in figure 1 should start before the grinder, and the grinder should start before the blenders.

There is also a "stopping sequence" when the equipment which is running must be stopped in the correct sequence. In the example, the blenders should stop first, the grinder should clear itself of feed before stopping, and the conveyor auger should be the last to stop. Very rarely are the starting and stopping sequences the same.

This division of the control process into two distinct sequences requires that the controls themselves have two "states." One state is when the controls are prepared for the starting sequence. The other

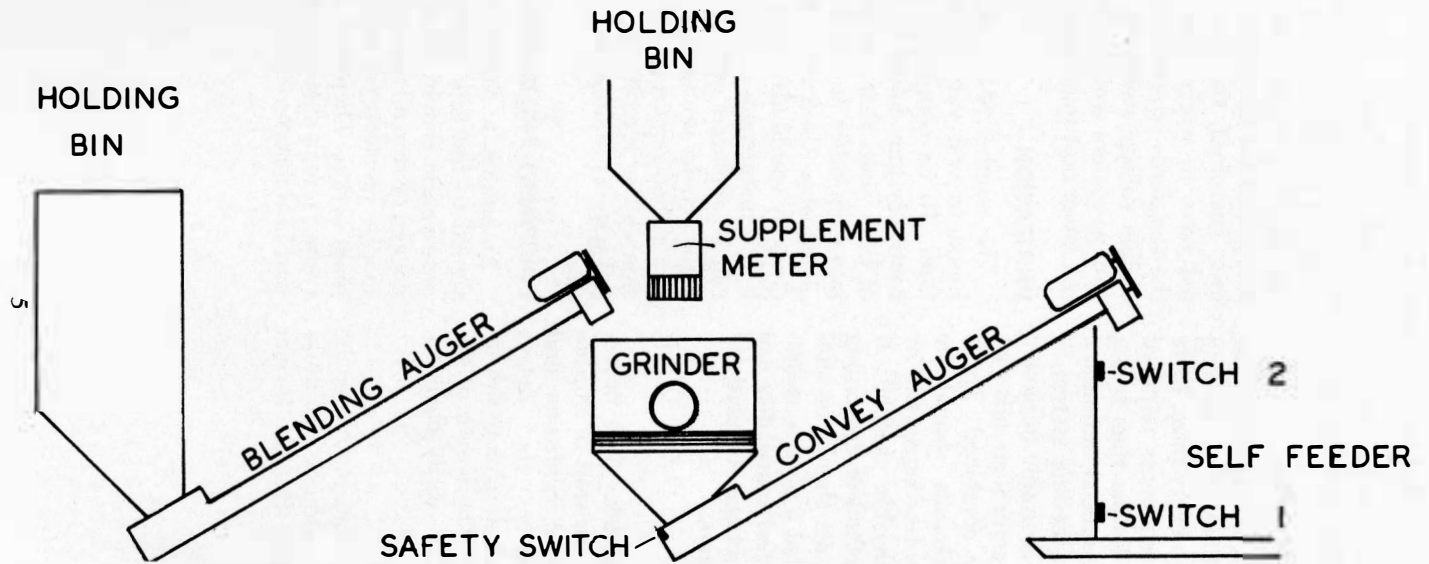

Figure 1. A typical arrangement of equipment for an automatic feeding system.

state is when the controls are prepared for the stopping sequence.

FLEXIBLE CONNECTIONS

Because some combination of the five basic functions of a feeding system is used on every farm, there is a variety of sequences required of the controls. Rather than trying to engineer a special automatic control for each feeding system, it would be more desirable to have a system of basic control circuits that could be easily combined. These basic control circuits should be adaptable to any feeding system by some simple, flexible method. If possible, the method of combining the control circuits should be simple enough so that a person unfamiliar with electrical schematics can make the connections required for a particular system.

DELAYS

Often a time delay will be required in either the start or stop sequence. To avoid confusion and excessive circuitry, the delays should be easily interchangeable in either sequence. The length of delay should also be easily changed.

LOW VOLTAGE

Signaling switches may often be installed in wet or dusty conditions around livestock. Often the farmer

himself may want to install the switch or change its location. A low voltage (24 volts or less) supply to the signaling switch would eliminate most of the danger of shock and fire. Therefore, the farmer would not have to worry about meeting the standards required for safe use of line voltage switching. The low voltage system would allow him to use lower cost materials.

UNITIZATION

The number of required control functions will vary from farm to farm. To be completely flexible a control system should be composed of basic units that can be plugged into each other and that are interchangeable. Unitization of the basic circuitry would also solve the problem of maintenance. The faulty unit can be replaced with another unit while repairs are made in the shop of a skilled repairman. Also, expansion and/or alterations of the control system are simplified by unitization.

EQUIPMENT PROTECTION

An automatic control system designed to function without human observation should be able to disengage or stop all equipment safely in case of electrical or mechanical malfunction. Therefore, the safety control circuit should be an integral part of the control design.

Design of Controls for Farm Automation

The first major obstacle was to design a control system having a simple but flexible method for selecting the sequence of operations. A flexible starting sequence was not difficult to visualize. A signal can energize a relay coil as shown in figure 2. An extra set of contacts can then signal when the relay completes the power circuit. This signal can be used to energize a succeeding relay. This arrangement is especially adaptable to low voltage signaling circuits which require a power relay in order to handle line voltages.

By making a ground connection inside of the control unit and bringing the "start" and "on" connections to the front of the panel, a series of these relay circuits can be readily (and simply) sequenced. Short patch cords (wires with plugs on both ends) can be used to connect the "on" signal of one relay circuit with the "start" of the succeeding circuit. This sequencing is simple

enough to be done by people unfamiliar with the electrical components inside the control panel.

The signal can also be easily delayed by using a thermal delay circuit similar to the one sketched in figure 3. The heater can be energized by the signal; there is a delay until the bi-metallic strips are heated enough to close the contacts. Thermal delays are relatively low in cost, can be easily interchanged (by using a tube socket mounting), and their accuracy is sufficient for the majority of farm applications.

Grounding the heater inside the control unit and bringing the "in" and "out" connections to the front of the panel allow the delay to be connected between power relay circuits by patch cords. Thus, any starting sequence with appropriate delays can be selected merely by connecting basic power relay and delay circuits with a signal "path" of patch cords.

For example, again referring to

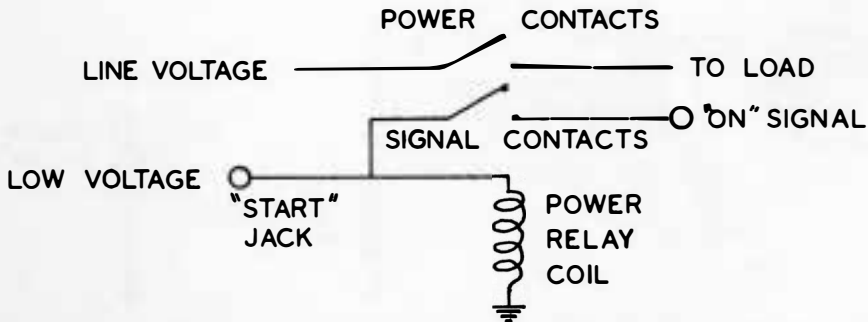

Figure 2. Schematic diagram of power relay showing "start" jack and "on" signal connections.

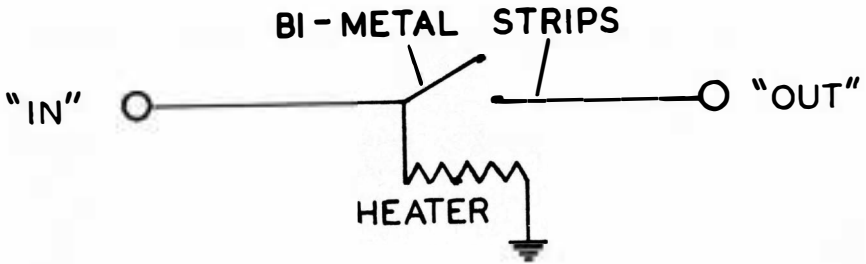

Figure 3. Diagram of thermal time delay relay showing arrangements for "in" and "out" connections.

figure 1, suppose there are three power relay circuits, one for the conveyor auger, one for the grinder, and one for both the blending and supplement meter. When the feeder runs empty, a signal from switch #1 can be used to energize the power relay for the conveyor. The signal that the conveyor is on can energize the power relay for the grinder. In turn, the signal that the grinder is on can energize the power relay for the feed meters. However, this signal should first pass through a delay circuit while the grinder gets up to speed.

As the feed starts to fill the feeder, it will reach a point where

switch #1 will be pressed. This will break the signal that energizes the power relays and all of the equipment will be stopped. This is not good because the feeder is not yet full and the grinder and conveyor augers are filled with feed when they are stopped. Therefore, when all of the equipment has started, the relay circuits should somehow remain activated until definitely signaled to shut off. In other words, the "state" of the control circuits should be changed to the stop sequence condition. This can be done by using a relay circuit as shown in figure 4.

The circuit can be located be-

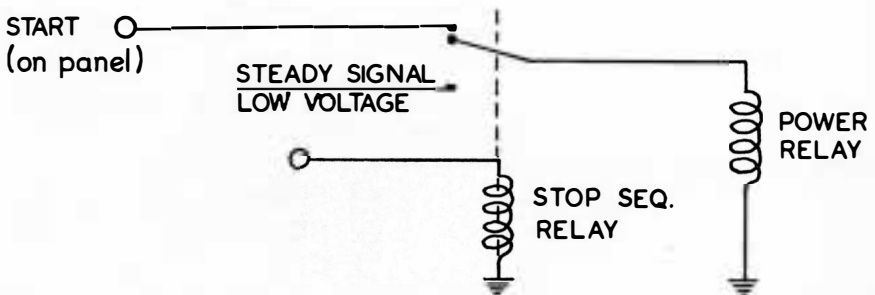

Figure 4. Stop sequence relay connections required to transfer the control signal from the "start" jack to an internal low voltage source.

tween the "start" connection on the panel and the power relay. The function of this relay is to transfer the source of signal from the "start" jack to a steady signal source within the control units. In effect, this relay converts the series starting sequence connections of the power relays into a parallel arrangement, illustrated by the block diagram in figure 5. This relay must be a "make before break" relay, because it must make with the internal steady signal before breaking the signal that originally energized the power relay. This relay will be referred to as the stop sequence relay because it prepares the controls for the stopping sequence.

The signal to energize this relay can come from the last power relay that is activated (see b of figure 5). However, once the stop sequence

relay is activated, it should remain energized until the controls have shut off all of the equipment. To insure that it remains energized until the last power relay is shut off, the stop sequence relay must therefore connect as many parallel sources of voltage for itself as there are power relays. One of these sources can then be interrupted as each power relay is shut off. When all parallel sources are interrupted the stop sequence relay returns to normal. This prepares the controls for the starting sequence again. Figure 6 shows a simplified schematic of an arrangement that can be used to secure the parallel signal source for the stop cycle relay. In this arrangement an extra set of contacts must be used for each power relay.

Since the function of the stop sequence relay can be performed for

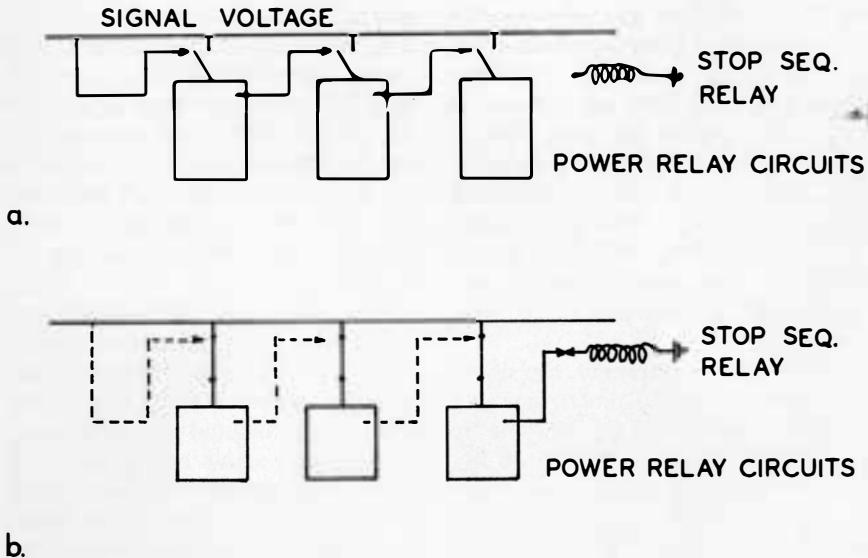

b.
Figure 5. Block diagram showing the principle of operation of the stop sequence relay.

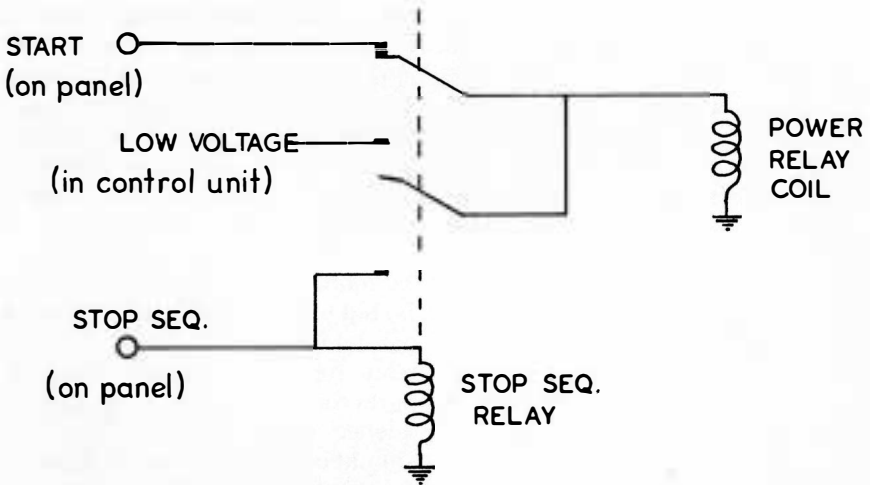

Figure 6. The feedback arrangement required to insure that the stop sequence relay remains energized.

all power relay circuits simultaneously, only one relay is required providing it has a pair of contacts for every power relay in the control system. However, use of only one stop sequence relay eliminates the possibility of making a unitized control system. The advantages of unitization justify the extra cost of a stop sequence relay per power relay. These relays can be connected in parallel within the control units. To activate them, the "on" signal from the last power relay is connected into a single jack on the control panel.

To stop the equipment, the signal to the power relays must somehow be interrupted. This can be done by using a third relay as shown in figure 7. When this relay is energized it will break the signal connection to the power relay coil. Notice that it also interrupts the feedback connection to the stop sequence relay

coil. If this were not done, the power relay would remain energized as long as the stop sequence relays.

At the same time, the stop relay makes a connection to indicate that it is activated and, therefore, that the equipment has been shut off. This "off" signal can now be used to energize a succeeding stopping relay. By observation, it will be obvious that in order to start and stop the equipment individually there must be a stop relay for every power relay.

The "stop" and "off" connections of the stop relay can be brought to the front of the panel like the "start" and "on" connections of the power relay. The original signal to stop the feeding system can be received at the proper time from an external source, such as switch #2 in figure 1. Thereafter, the stopping relays can be "patched" together in any required sequence. The signal that

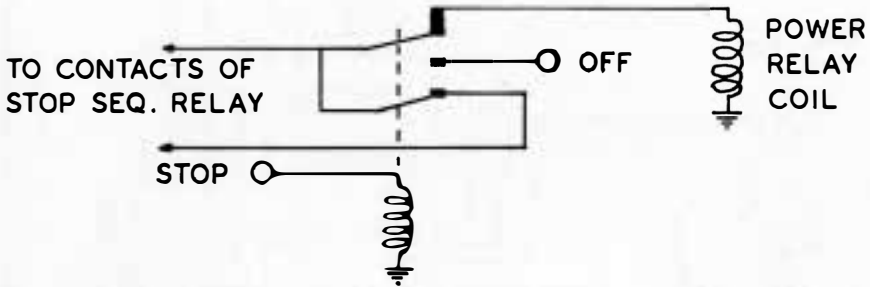

Figure 7. Relay connections required to disconnect power relay and interrupt feedback to stop sequence relay when signal is put into stop jack.

activates these relays can also be delayed by the same circuitry that delayed the starting signal for the power relays.

Figure 8 shows a complete diagram of the unitized power relay control circuit. The "skip" switch shown in the schematic is a manual toggle switch that performs the same operation as the stop relay. The circles at the top of the diagram indicate the low voltage jacks to the front of the control panel. The "steady signal jack" is a source of low voltage that can be used to supply external signalling switches. The horizontal lines indicate the connections that pass through the unitized circuit, and that are transferred to another power relay circuit by matching plugs and sockets.

The actual power relay unit is shown in figure 9. Notice the location of the power relay, the stop sequence relays, and the stop relay. Figure 10 shows the front of the control panel with the low voltage jacks, the "skip" switch, and the time delay tube socket. Also visible in figure 10 is the power outlet on the bottom and the prongs of the transfer plug on the side of the unit.

No provision for fusing was made for these unitized power relays because these relays may often activate two or more motors or other electrical equipment. If two or more power circuits are activated from the same power relay, it is more economical to arrange for separate external protection for the various circuits. If only one circuit is activated, fusing can be simply accomplished by using a SRU (fuse and outlet box cover) unit in place of the outlet.

To supply the low voltage signal power necessary to operate the relays, the transformer was built into a separate unit. A prototype of the unit is shown in figure 11. This unit is called the "master" unit because one is required to supply the low voltage signals for each control system and also because it contains the only jack by which the stop sequence relays may be activated. In other words, it determines whether the power relay units (which may be called "slave" units) are in the starting sequence or stopping sequence state. Also, for convenience, the master unit contains a relay that provides a "starting" signal that can

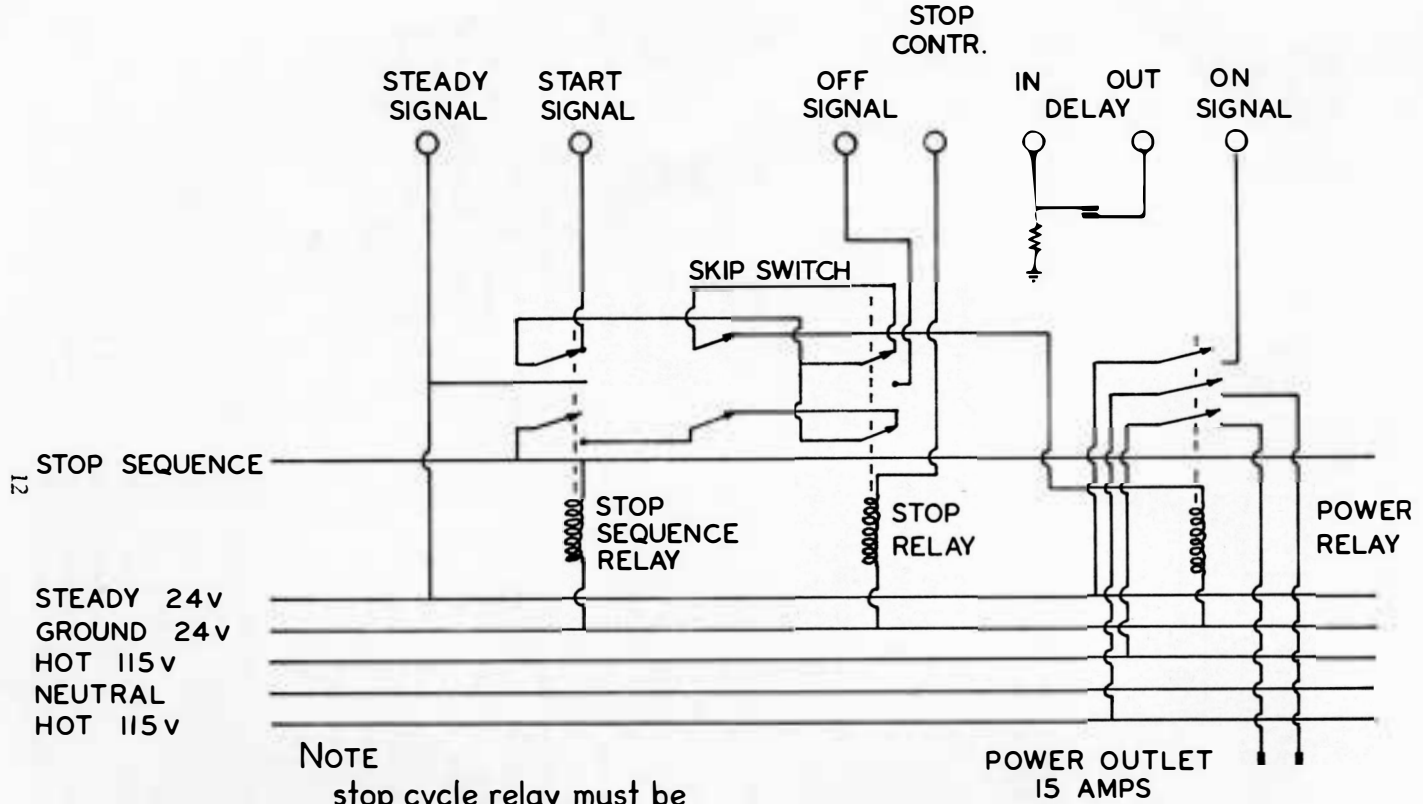

Figure 8. Complete wiring diagram of the standard power relay unit. A skip switch is included to allow manual operation similar to that of the stop relay.

Figure 9. The wiring arrangement of a standard power relay unit. Power relay is at bottom of photo, stop sequence relay at lower right, and stop relay at upper right.

be used for starting the "slave" units. This relay is energized with the stop sequence relays. When this happens it transfers the signal to another jack. This signal can then be used for stopping the "slave" units. Thus, the relay allows the entire control system to be connected for a self-repeat cycle.

A schematic of the master unit is shown in figure 12. Notice that in addition to a fuse on the transformer secondary, there is a "jumper safety" connection. The jacks for this connection are located on the front of the panel of the master unit. Unless there is a complete cir-

Figure 10. Front and sides of the standard power relay unit.

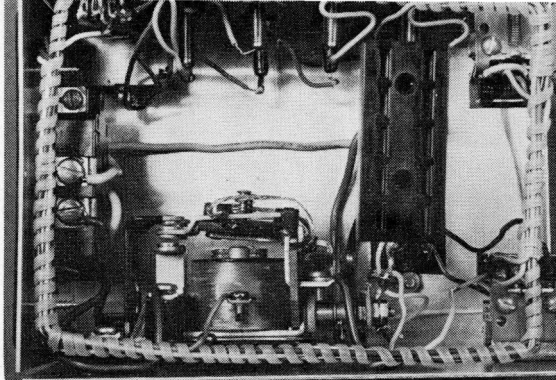
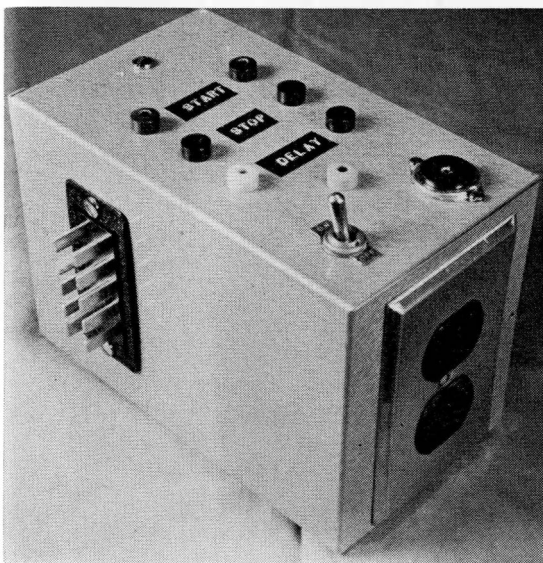

cuit between these jacks, the entire control system is inoperative.

This "jumper safety" allows a very simple means of protection against mechanical failure in a feeding system. A series circuit through several normally closed snap-action switches can be used in the place of a patch cord. These switches can be located in positions such that they would be tripped if the machinery should fail and the feed began to pile up. For example, should the conveyor auger in figure 1 fail, the ground feed would begin to pile up until it contacts a safety switch. This switch would open the "jumper safety" circuit and thereby stop all of the equipment immediately.

A special sequence, encountered since these controls were originated, is a situation that requires a motor to be reversed during the feeding operations. There are several occasions to use a reversing motor on the farm: to lower and then raise a silo unloader, to open and then close an air-tight door, and to rotate and then return the diverting board of a tube bunk feeder.

The addition of a fourth relay circuit to the power relay units will produce a reversing motor control unit that is compatible to the rest of

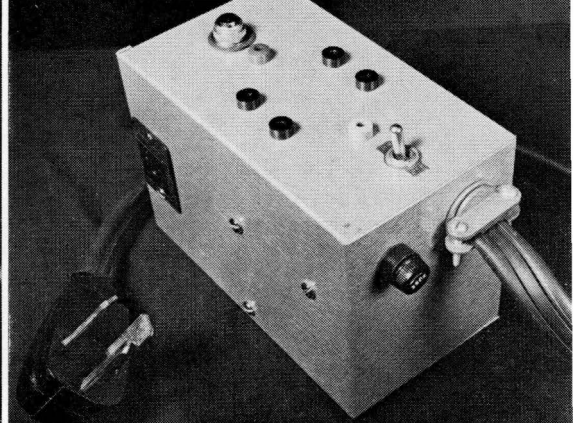
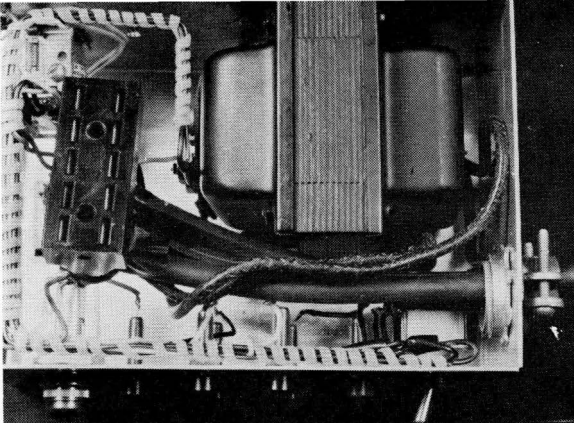

Figure 11. Two views of a prototype master unit showing arrangement of the transformer, relay, and exterior arrangement of jacks, switch, stop sequence light, fuse, and 30 amp plug.

the controls. The schematic of this circuit is given in figure 13. The only changes required on the front of the control unit are the addition of the reverse function jacks, the addition of a second stop jack, and an extra tube socket. The delay tube socket can be connected internally so that a signal into the reverse jack will first stop the reversing motor and delay the reversing function for a few seconds. A prototype unit is shown in figure 14.

The reverse function jacks can be installed on the line usually reserved for the steady signal jack (which can be eliminated on this control unit). The use of the double stop connections allows the reversing motor to be started (via the regular start jack), then stopped (via stop #1 jack), later reversed (via the reverse jack), and finally stopped (via stop #2). The connections to the reversing contacts are not specified because these depend upon the type of motor to be reversed. Each reversing motor can usually be connected to its control unit by a four-prong plug and socket arrangement.

The most serious electrical malfunction of the automatic control system would be the overheating or short circuit of a motor or other electrical equipment. This equipment can be protected by fusing, but should the fuse blow it is desirable that there is a method of immediately stopping the entire system before costly "jams" occur. This protection can be readily furnished by a photo-relay unit as shown schematically in figure 15 and in the photograph of figure 16. Small light bulbs can be connected in parallel with the fuses in the power circuit. Normally there is no voltage drop across the light bulbs but, when a fuse flows, the full voltage will appear across the light and cause it to glow. This light can be used to activate the simple photo relay circuit shown in the schematic that, in turn, activates a relay that breaks the "jumper safety" connection, turns on a holding light, and also supplies power to an outlet for external signal lamps. When the fault has been corrected, a reset button can be pushed which shuts off the holding light.

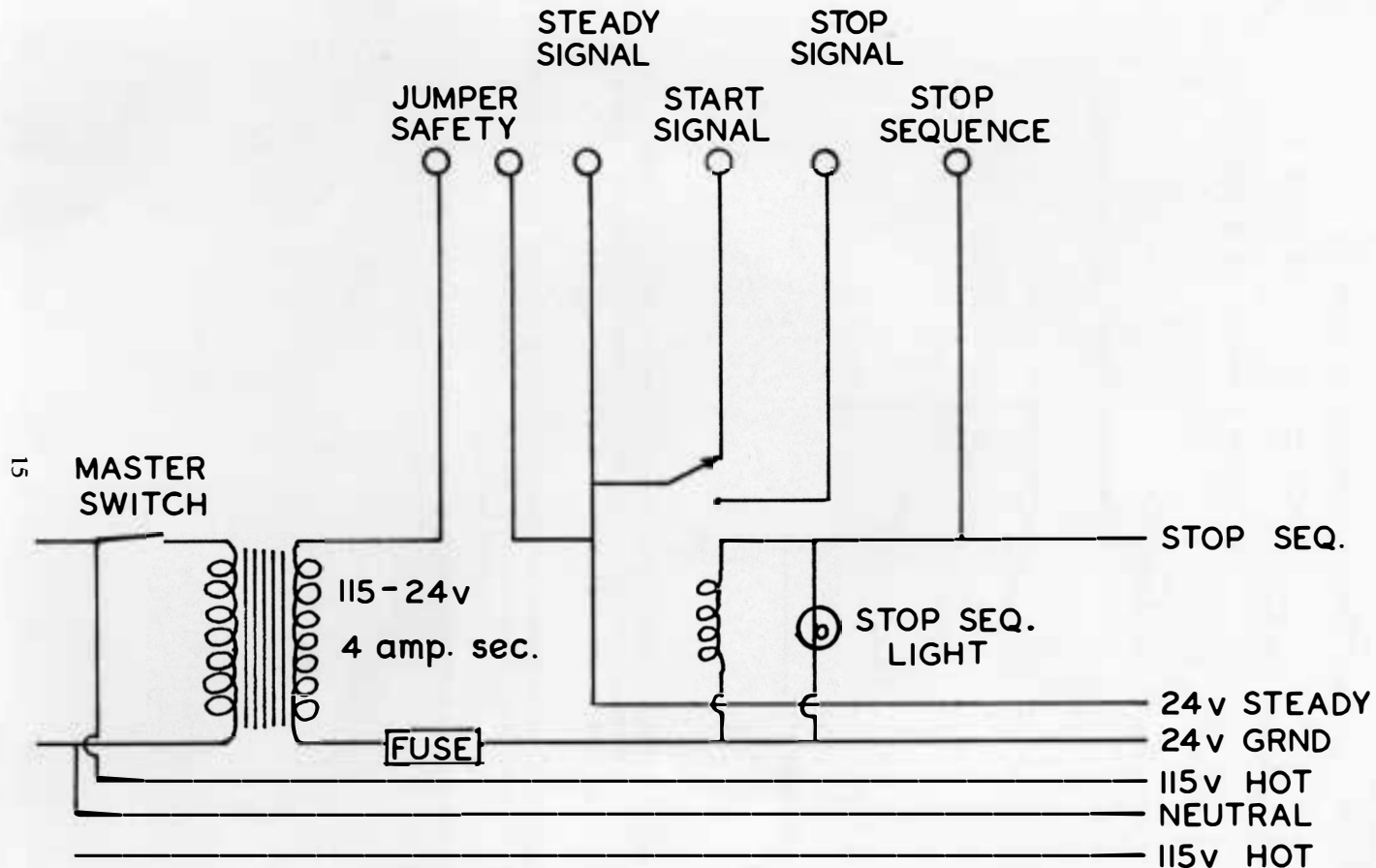

Figure 12. Complete wiring diagram of the master unit showing a transformer and stop sequence connections.

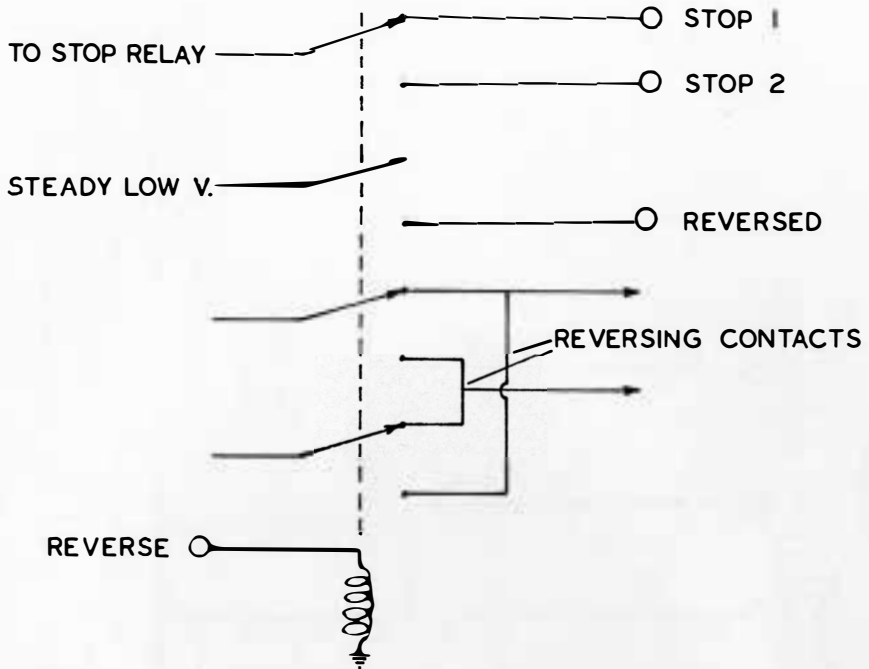
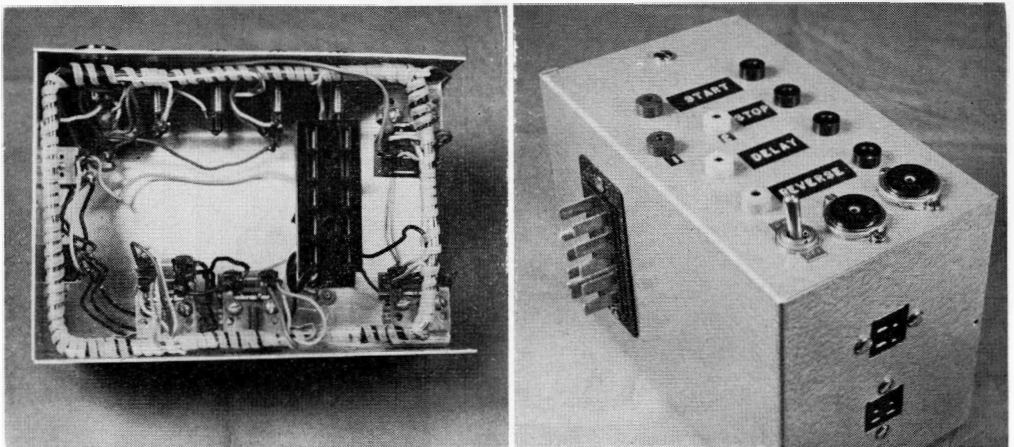

Figure 13. Schematic diagram of the reversing relay included in the reversing unit. This relay is connected between the power relay and the power outlet of a standard power relay unit.

Figure 14. Wiring arrangement and external view of the reversing slave unit. Notice that the power relay of standard slave was replaced with a smaller relay (interior view, center) to allow room for the reversing relay (interior view, left).



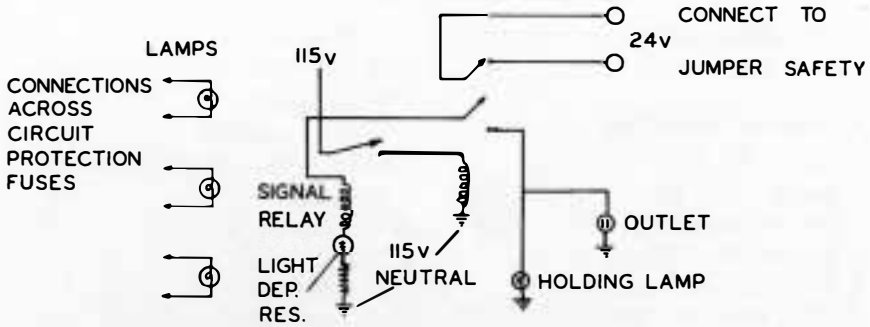

Figure 15. Complete circuit diagram of the safety unit.

One demonstration panel, one small prototype model with only two "slave" units, and four control systems of the type shown in figures 9, 10, 11, and 16 have been constructed. All have functioned with a minimum of maintenance. The prototype model has been used since August 1960 in a humidity control circuit for an experiment at South Dakota State College. The only failure was a loose screw on the power relay. The demonstration panel has been used in demonstrations at various affairs since June 1960. Usually the completion of the patch cord connections to se-

quence a model feeding system was so simple that people called from the audience could do the hook-up.

A set of these control units was installed at a farm near Humboldt, South Dakota. This installation provides a remote control center for a silage feeding system. Another system of controls has been installed on a farm near Watertown, South Dakota. This control system actually controls two separate feeding systems: a self-feeder type of system as shown in figure 1, and a limited feed system operating on a timed basis.

Figure 16. Two views of the system safety unit, showing the photo-sensitive resistor, relays, light bulbs, and the exterior arrangement of jacks, reset button, indicating lamp, and plugs for light bulbs.

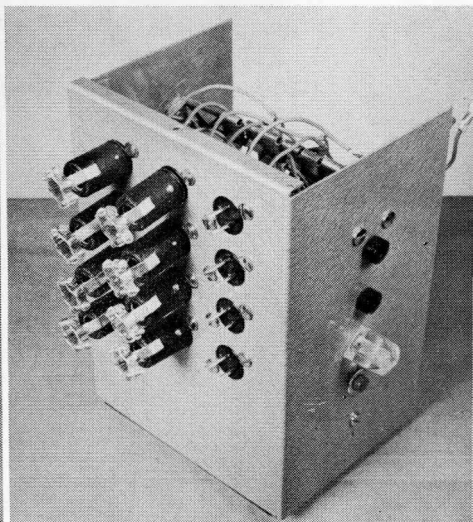
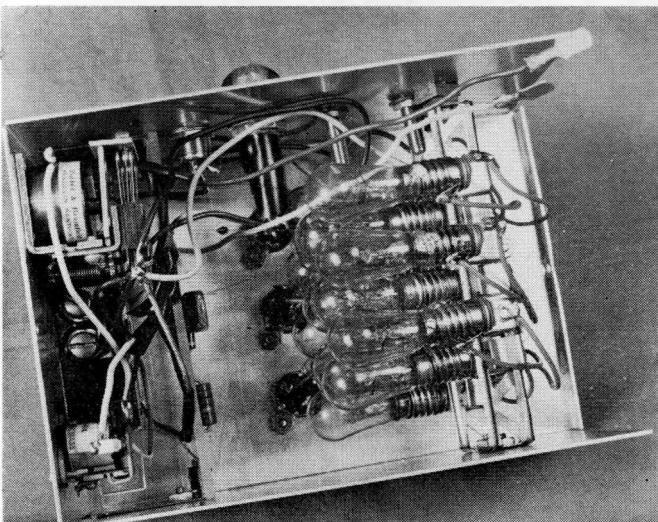

Parts List

(Available through electronic supply companies)

I. Standard Slave Unit

- 1 box 7 x 5 x 4"
- 1 power relay, 24 volt, 3PDT, "Potter & Blumfield," PR11AL5 or equivalent
- 2 24 volt, DPDT relays
- 1 10 point multiplug (P-410-SB Cinch Jones or equivalent)
- 1 10 point multi-socket (S-410-SB Cinch Jones or equivalent)
- 7 Banana jacks
- 7 Banana plugs
- 1 Power outlet
- 1 Miniature tube socket
- 1 DPST toggle switch
- #14 stranded wire
- #14 solid wire
- #18 solid wire
- #20 solid wire
- Machine screws and sheet metal screws

II. Master Unit

- 1 Box 7 x 5 x 4"
- 1 24 volt, DPDT relay
- 1 10 point multi-socket (S-410-SB Cinch Jones or equivalent)
- 1 4 point multi-socket (S-404-SB Cinch Jones or equivalent)
- 6 Banana plugs
- 6 Banana jacks
- 1 SPST toggle switch
- 1 24 volt transformer, 100 watts

- 1 Bulb socket
- 1 24 volt bulb
- 1 Fuse holder
- 1 $\frac{3}{4}$ " box connector
- 1 30 amp, 240 volt plug (dryer connection)
- #14 stranded wire
- #18 solid wire
- #20 solid wire
- Sheet metal and machine screws

III. Safety Unit

- 1 Box 7 x 5 x 4"
- 1 4 point multiplug (P-404-SB Cinch Jones or equivalent)
- 1 115 volt, DPDT relay
- 1 Sensitive relay (Sigma 11FZ-9000 or equivalent)
- 1 8200 ohm resistor
- 1 2000 ohm resistor
- 1 Light dependent resistor
- 12 240 volt signal lamp
- 1 120 volt lamp
- 13 Lamp holders
- 12 2 point sockets (S-302-AB Cinch Jones or equivalent)
- 12 2 point plugs (P-302-CCT Cinch Jones or equivalent)
- 1 115 volt indicator light (neon)
- 1 Miniature push button switch
- 1 Power outlet (115 volt)
- 2 Banana jacks
- 2 Banana plugs
- #18 solid wire
- Sheet metal and machine screws