

South Dakota State University  
**Open PRAIRIE: Open Public Research Access Institutional  
Repository and Information Exchange**

---

Bulletins

South Dakota State University Agricultural  
Experiment Station

---

4-1-1961

## A New Approach to Swine Shade Construction

C. N. Hinkle

H. G. Young

Follow this and additional works at: [http://openprairie.sdstate.edu/agexperimentsta\\_bulletins](http://openprairie.sdstate.edu/agexperimentsta_bulletins)

---

### Recommended Citation

Hinkle, C. N. and Young, H. G., "A New Approach to Swine Shade Construction" (1961). *Bulletins*. Paper 495.  
[http://openprairie.sdstate.edu/agexperimentsta\\_bulletins/495](http://openprairie.sdstate.edu/agexperimentsta_bulletins/495)

This Bulletin is brought to you for free and open access by the South Dakota State University Agricultural Experiment Station at Open PRAIRIE: Open Public Research Access Institutional Repository and Information Exchange. It has been accepted for inclusion in Bulletins by an authorized administrator of Open PRAIRIE: Open Public Research Access Institutional Repository and Information Exchange. For more information, please contact [michael.biondo@sdstate.edu](mailto:michael.biondo@sdstate.edu).

# A NEW APPROACH TO SWINE SHADE CONSTRUCTION

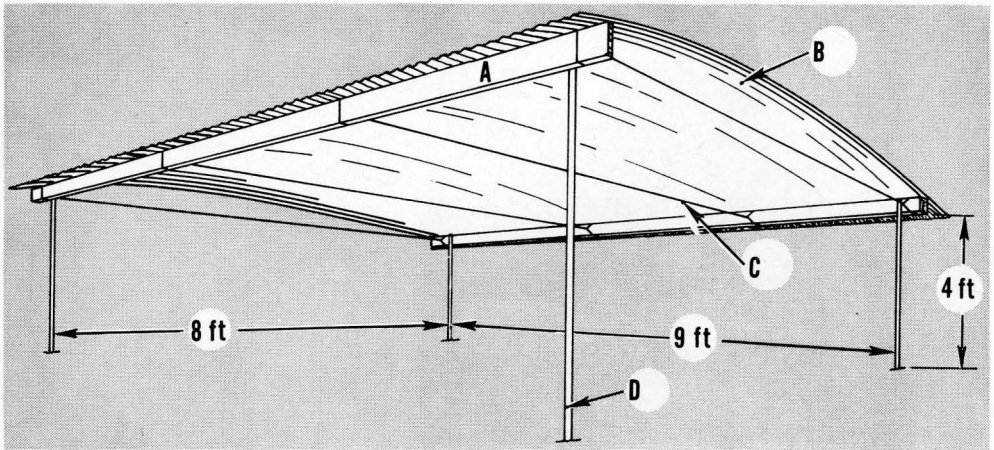

AGRICULTURAL ENGINEERING DEPARTMENT  
AGRICULTURAL EXPERIMENT STATION  
SOUTH DAKOTA STATE COLLEGE, BROOKINGS

## CONTENTS

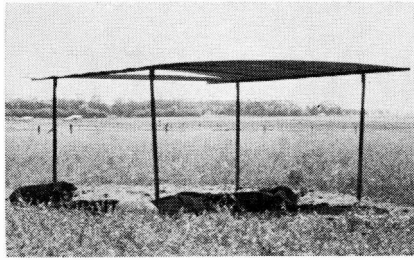

Introduction.....	3
Shade Construction .....	4
Results and Conclusions.....	8

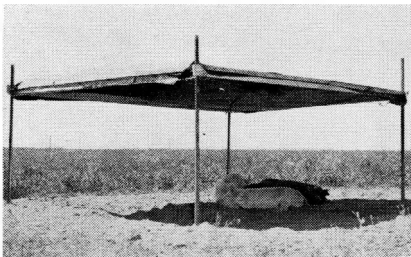

## FIGURES

1. Figure 1. Details of socket used to attach the shade frame to the steel fence post supports.
2. Figure 2. Details of "Hook Bolt" Fastener.
3. Figure 3. Polyethylene Covered Shade.
4. Figure 4. Plywood or Corrugated Sheet Metal Shade.
5. Figure 5. Arched Corrugated Sheet Metal Shade.

# A NEW APPROACH TO SWINE SHADE CONSTRUCTION

C. N. HINKLE and H. G. YOUNG<sup>1</sup>

A shade or field shelter in a pasture rotation system for handling swine should be portable to be used effectively. In its true sense, the word "portable" is closely related to the word "carry"; something which is portable can be carried. But most plans for portable shades call for heavy timber such as 4 x 4's or 4 x 6's for skids, 4 x 4's for posts, and a collection of framing lumber for ties, braces, supports, and reinforcement. All of this still has to be topped by the covering material which actually shades the area below. This common type of shade becomes difficult to carry, both physically and financially.

A project was initiated by the Agricultural Engineering Department at the South Dakota Agricultural Experiment Station to design a type of swine shade which would not require all the heavy timber under-framing of the current swine shade plans, and which would be actually "portable." The need for such swine shelters has

been established; research results from other stations have shown that some shading device, either natural or artificial, is necessary to protect swine, especially the heavier ones, from the direct heat of the sun. Extensive work conducted at California<sup>2,3</sup> shows the effects of different types of surfaces and shade materials on the radiant heat load beneath the shade. Another report, one from Purdue University<sup>4</sup> on the effectiveness of

<sup>1</sup>Dr. Hinkle and Mr. Young are associate professor and assistant professor, respectively, in agricultural engineering.

<sup>2</sup>T. E. Bond, C. F. Kelly, and N. R. Ittner. "Radiation Studies of Painted Shade Materials," *Agricultural Engineering*, 35:389-392, June, 1954.

<sup>3</sup>C. F. Kelly, and T. E. Bond. "Effectiveness of Artificial Shade Materials," *Agricultural Engineering*, 39:758-759, December, 1958.

<sup>4</sup>F. N. Andrews, W. E. Fontaine, A. A. Culver, T. L. Noffsinger, and V. A. Garwood. "Effectiveness of Various Types of Shade on the Growth of Swine in a Normal Summer Environment," *Journal of Animal Science*, 19:429-433, May, 1960.

various types of shade on the growth of swine in a normal summer environment, concluded that there were no differences between materials used and no measurable effects of roof color on rate of gain of swine. While these studies may not agree on the effectiveness of different types of shading materials, their findings support the need for some type of shade for swine to maintain or improve rate of gain.

The objective of the South Dakota project, then, was to combine new design techniques and a variety of surface and shade materials into lightweight, economical swine shelters. All of the shades built and tested fit these categories: they are portable or easily moved; they can be dismantled into several components and can be moved by truck or other flat-bed type of carrier from one location to another or to winter storage. The durability of the various shade designs was determined in tests conducted during the summer of 1958 through 1960 with one of the swine herds of the Animal Husbandry Department.

### SHADE CONSTRUCTION

The shades tested consisted mainly of lightweight roof frames attached to steel fence posts. The new design technique introduced was that shade shelters were developed with rigidity in the horizontal plane (shade frame) and to permit a small amount of deflection in the vertical plane (steel fence posts).

A shade frame 12 feet square was designed and utilized during a greater part of the tests. The main frame was constructed from 2 x 4 framing lumber and support across the interior of the frame was supplied by either 2 x 4's or 1 x 8's, depending on the material used to cover the shade. Rigidity of the frame was accomplished by the use of plywood gusset plates glued and nailed at each corner.

Steel fence posts, 6 feet long, were used to support the shades in all instances. It was felt that this type of support could be easily used, flexible, adaptable to any slope, and yet strong enough to adequately support the shade. The posts were attached to the frame

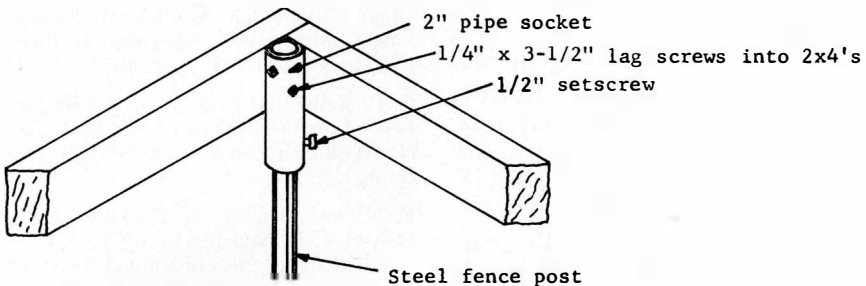

Figure 1. Details of socket used to attach the shade frame to the steel fence post supports.

by two methods. One consisted of an 8-inch socket made from 2-inch diameter steel pipe bolted to each corner of the frame. The top of the post was inserted in the socket and secured by means of a set-screw tapped in the lower end of the socket. The second type consisted of a hook bolt extending through the frame, which clamped the steel post to the shade frame. De-

to the frame. The most satisfactory method of fastening was to stretch the cover tightly over the frame and secure the edges first. In order to obtain an effective fastening around the edge, it was necessary to roll the nailing strip at least two turns in the edge of the polyethylene cover and then nail it to the frame, spacing the nails approximately 6 inches on

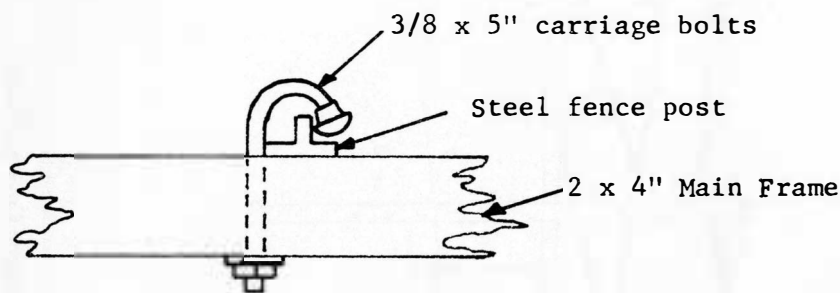

Figure 2. Details of "Hook Bolt" Fastener.

tails of the support attachments are shown in Figures 1 and 2.

Several covering materials were used during the study to determine their relative durability, economy, and ease of fabrication. The materials studied were polyethylene plastic, corrugated galvanized steel, corrugated aluminum, and exterior plywood.

Polyethylene covers in thicknesses of 4, 6, and 10 mils were used during the test period. Black polyethylene coverings were of 4- and 6-mil thickness, while the 10-mil cover was an experimental extruded type black on one surface and white on the other.

Nailing strips  $\frac{1}{4} \times 1$  were used to secure the polyethylene covers

center. This prevented any tearing or slippage of the cover. The center of the shade cover was tied down by placing nailing strips across the top of the shade, directly over the interior supports, and nailing the strip down starting at the end and continuing in as far as one could reach using the same nail spacing. Construction details of the polyethylene covered shade are shown in Figure 3.

The corrugated sheet metal and plywood were applied to the basic shade frame in a similar manner. Two 2 x 4 framing members were nailed between the main frame to furnish the required support for the covering material (see Figure 4). Plywood gusset plates were not

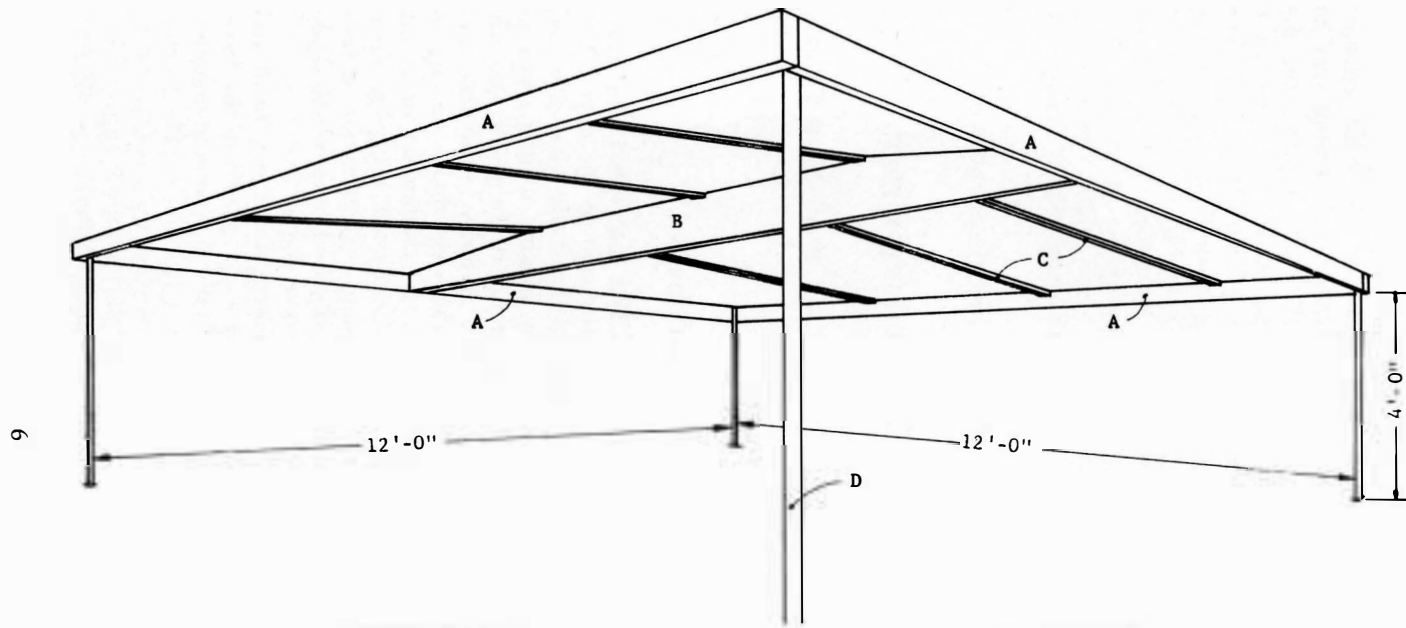

CUTTING LIST

CAPACITY

Item	No.	Description	Hog weight	Square feet per head
A	4	2" x 4" x 12'-0"	40- 75 lbs.	3
B	1	1" x 8" x 12'-0"	75-125 lbs.	4
C	3	1" x 2" x 12'-0"	125-200 lbs.	6

Figure 3. Polyethylene Covered Shade.

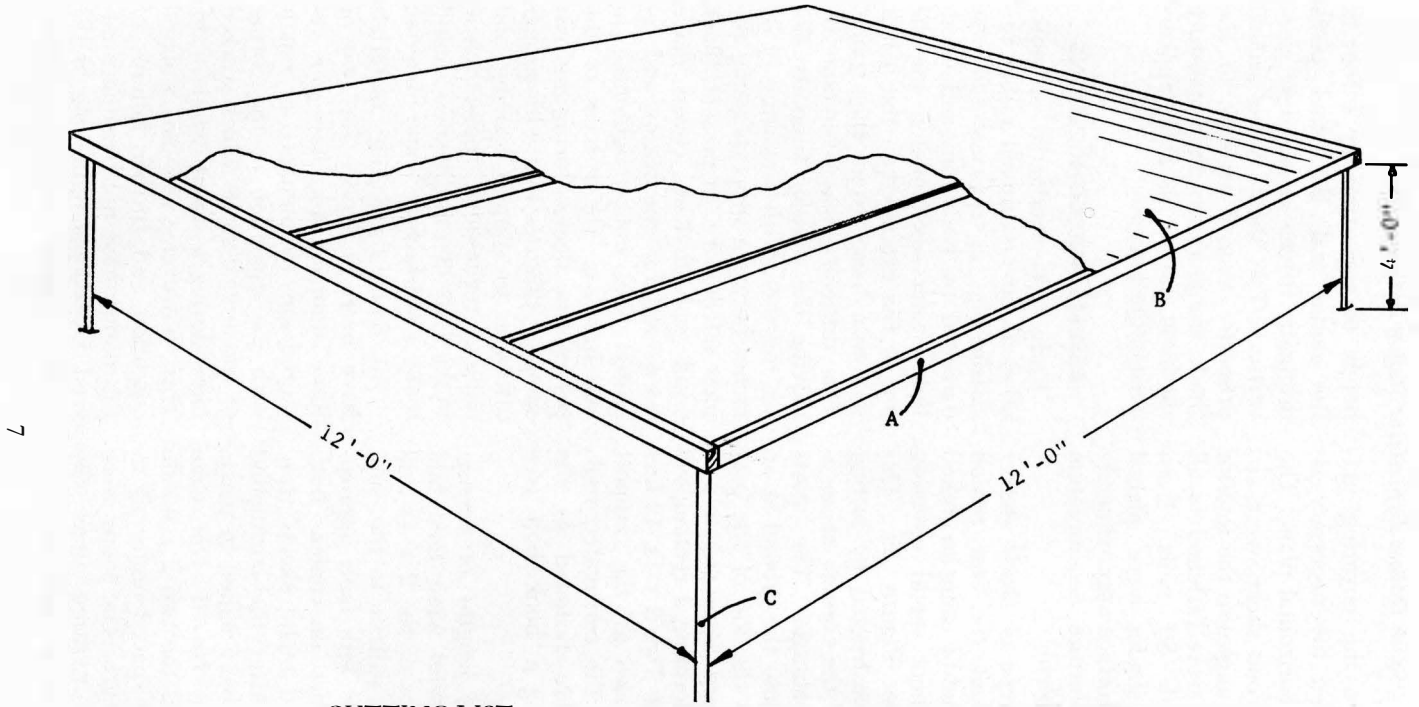

7

CUTTING LIST			CAPACITY	
Item	No.	Description	Hog weight	Square feet per head
A	6	2" x 4" x 12'-0"	40- 75 lbs.	3
B		Sheet metal or exterior plywood	75-125 lbs.	4
C	4	2" x 6' steel post	125-220 lbs.	6

Figure 4. Plywood or Corrugated Sheet Metal Shade.



required since the covering material furnished the necessary rigidity in the horizontal plane. The metal or plywood sheets were applied at right angles to the interior supports and were fastened to all members with 8d nails. Even though the shades were placed with the top surface approximately horizontal, moisture accumulation was not a problem.

A second type of shade shelter used throughout the test period was constructed by using an arched corrugated sheet metal covering material (see Figure 5). This shade was constructed by setting steel posts at the corners of an 8-by 9-foot rectangle. The posts were driven into the ground at an angle so that the top of the post sloped outward approximately 6 inches, thus forming a rectangle 8 feet by 10 feet. Two 2 x 4's, 12 feet long, were used as the support members for the corrugated roofing. They were fastened to the post top using a hook bolt (see Figure 2).

Twelve-foot lengths of corrugated sheet metal were then laid across the tops of the 2 x 4's and nailed in the valleys to the support members with nails approximately 5 inches on center. Both new and used metal sheets were satisfactory. After the corrugated metal sheets were nailed in place, four loops of No. 9 wire were looped around the two 2 x 4 side members and spaced uniformly along their length. The loops were tightened by twisting until the corrugated sheets arched to a

height of approximately 1 foot in the center and the steel posts originally driven at an angle were vertical. The sheets were arched primarily to give rigidity to the shade frame rather than moisture shedding ability, as their appearance might indicate.

## **RESULTS AND CONCLUSIONS**

Early tests conducted on polyethylene covers proved rather unsatisfactory, as the material was damaged by both rain and wind. Rain water accumulated on the top to the extent that the cover was torn loose from the frame. This difficulty was overcome by moving the interior supports closer together, with a spacing of 30 inches between supports being the most satisfactory. At present, black 4-mil polyethylene covers have been used for one season and required only minor tightening in one instance. The success of the polyethylene shades during the past summer indicates that with proper attention to support spacing and nailing techniques, polyethylene in the 4- and 6-mil thickness should make a satisfactory shade material.

All other covering materials have been in service for two or three summers and have not required any maintenance or repair with the exception of the corner of one arched shade which worked loose during a severe wind storm. This, however, was an isolated condition and further failures of this nature have not been encountered. Occasional tightening of the tension wires was also necessary

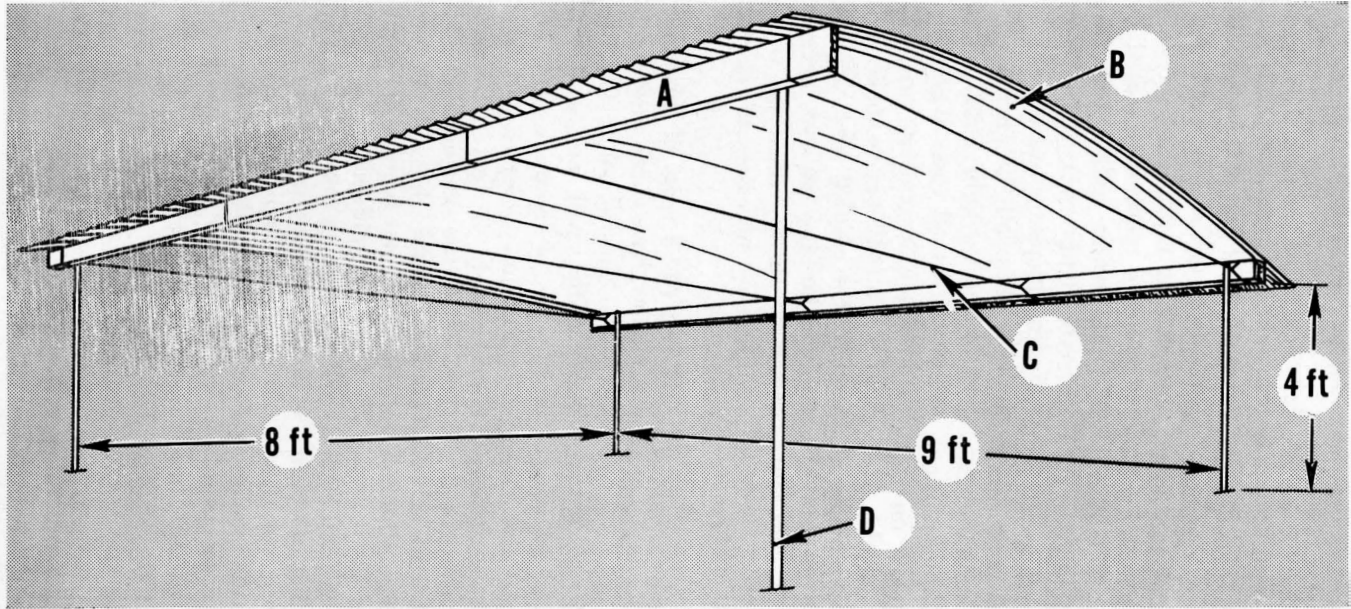

## CUTTING LIST

## CAPACITY

Item	No.	Description	Hog weight	Square feet per head
A	2	2" x 4" x 12'-0"	40- 75 lbs.	3
B	6	Corrugated sheet metal 26" x 12'-0"	75-125 lbs.	4
C	4	No. 9 steel wire, 4 loops 20', twisted	125-200 lbs.	6
D	4	2" x 6' steel post		

Figure 5. Arched Corrugated Sheet Metal Shade.

either because of stretching of the wires or their tendency to untwist.

To move any of the shades to another location or to dismantle them for winter storage, the hook bolts or sockets connecting the frame to the posts were loosened and the shade was lifted from the posts and handled as a unit. To reset the shades, the posts were driven in the new location and the shade replaced. If the tension wires were left in place on the arched sheet metal shade, the posts could be driven vertically at the proper spacing in the new location. Since the snow load capabilities of the shades are unknown, storage during the winter is recommended.

Originally, the arched corrugated sheet metal shade was nailed together with double headed nails. It was thought that this would permit easier dismantling of the shade for storage. It was found, however, that it was not necessary to separate the sheet metal from the 2 x 4's and on construction of subsequent shades of this type, common nails and lead headed screw-drive roofing nails have been used with equal success. All nailing has been in the valleys, but there is no reason to believe that ridge nailing would not be equally successful.

A factor that has considerable bearing on the use of the shades during this test was the size of the animals in the pens. Hogs weighing up to 75 pounds showed little need for shade and quite often could be found grazing during the

hottest part of the day. The heavier young hogs required shade during the hottest part of the afternoon and checks of the area would find them resting in the shade or seeking relief in mudholes created by rain and water spilled from the waterers. Hogs over 125 pounds were less tolerant to warm weather and would spend the greater portion of the daylight hours under the shade. In all cases where the shades were in constant use, the hogs had a tendency to make wallows in the shaded area. During dry weather the wallows became extremely dusty which on occasions made it necessary to relocate the shade.

During the 3 years of this study the shades have been used only for swine. This is not to say that these shades will not work for other types of livestock. It is obvious that any livestock less than approximately 3 feet in height could make use of this shade, although perhaps the polyethylene shade should not be used for poultry since it could be damaged by birds roosting on top. It is planned to splice several sets of steel fence posts together and place several of the shades in a cattle feed lot.

The idea of rigidity only in the horizontal plane has been successful and there are many more methods of making such shading devices than discussed in this report. Others have also used variations of the methods reported here with apparent success. It is

believed that this method of shade construction has truly resulted in a shade device which is lightweight, economical in construction, and thus easy to carry, both physically and financially. (State Project 316, Agricultural Engineering Department.)