

South Dakota State University  
**Open PRAIRIE: Open Public Research Access Institutional  
Repository and Information Exchange**

---

Bulletins

South Dakota State University Agricultural  
Experiment Station

---

2-1-1940

## Homemade Rubber Tired Carts and Trailers

H. H. DeLong

Follow this and additional works at: [http://openprairie.sdstate.edu/agexperimentsta\\_bulletins](http://openprairie.sdstate.edu/agexperimentsta_bulletins)

---

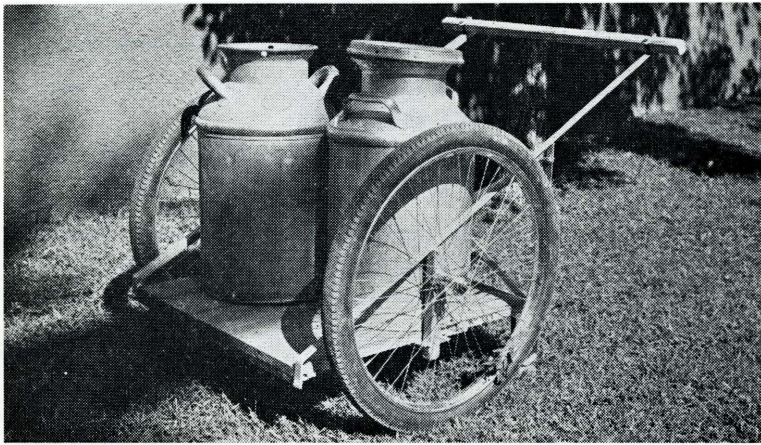
### Recommended Citation

DeLong, H. H., "Homemade Rubber Tired Carts and Trailers" (1940). *Bulletins*. Paper 333.  
[http://openprairie.sdstate.edu/agexperimentsta\\_bulletins/333](http://openprairie.sdstate.edu/agexperimentsta_bulletins/333)

This Bulletin is brought to you for free and open access by the South Dakota State University Agricultural Experiment Station at Open PRAIRIE: Open Public Research Access Institutional Repository and Information Exchange. It has been accepted for inclusion in Bulletins by an authorized administrator of Open PRAIRIE: Open Public Research Access Institutional Repository and Information Exchange. For more information, please contact [michael.biondo@sdstate.edu](mailto:michael.biondo@sdstate.edu).

# Homemade Rubber Tired Carts and Trailers

*Henry H. DeLong*



*Agricultural Engineering Department*  
**Agricultural Experiment Station**

South Dakota State College of Agriculture and Mechanic Arts  
Brookings, S. D.

## *Summary*

1. Used car wheels, axles, frames and second-hand tires and tubes have been used with good results in this project.
2. The pneumatic tire rolls more easily than a steel wheel on all but a very smooth, hard surface.
3. The tires with the larger cross-sections have proven more adaptable to farm cart uses than the small cross-section tire.
4. The large cross-section tire is bulky and adds greatly to the width of farm carts or seriously reduces cart capacity.
5. The large diameter wheel is superior to the small diameter wheel in both the steel wheel and in the pneumatic tired wheel.
6. A high inflation pressure gives the least rolling resistance with pneumatic tires on hard, smooth tracks.
7. A low inflation pressure gives the least rolling resistance with pneumatic tires on soft or rough tracks.
8. The 6-16 tire is by far the most popular size today. Second-hand casings and tubes in this size tire can be obtained easily and cheaply, whereas the less common sizes are more difficult to get.
9. The old steel disc automobile wheel can be cut down by a welder and a 6-16 drop-center rim welded on to make a trailer wheel which will use the popular sized tire.
10. The bicycle wheel is desirable only for very light carts which are to carry loads of 150 lbs. or less per wheel.
11. A trailer for moving brooder houses and farrowing houses can be made of old car parts and will prove useful to a farmer who has several such buildings to move annually. Such a trailer lightens the work, saves yards and lanes and prevents serious twisting of framework which the buildings receive when dragged on skids.
12. The low platform trailer has numerous uses about the farm. It can be equipped with water tank and sack rack for hauling feed and water to hogs on pasture.
13. Homemade equipment, if properly designed, can aid greatly in carrying out a system of raising hogs or poultry on clean ground.

## Table of Contents

Summary.....	2
Introduction.....	5
Method of Testing Draft of Carts.....	6
Relation of Diameter of Wheel to Draft.....	9
Steel Wheels vs. Pneumatic Tires.....	10
Inflation Pressures of Cart Tires.....	11
Effect of Load Size on Pneumatic Tire Width.....	11
The Design of Silage Carts.....	13
The Light Utility Cart.....	16
Type "A" Trailer For Moving Brooder and Farrowing Houses.....	19
Type "B" Trailer For Moving Brooder and Farrowing Houses.....	21
The Light, Low Platform Trailer.....	24
The Heavy, Low Platform Trailer.....	26
List of References.....	27

---

## List of Tables

Advantages and Disadvantages of the Three Types of Silage Carts.....	15
Brief Specifications of the Carts Used in the Study of Wheel Sizes and Types.....	18

## List of Figures

1. This Apparatus Was Used to Test the Draft of Carts .....	6
2. Comparative Draft of Large and Small Wheels, and of Steel vs. Rubber Tired Wheels.....	8
3. The Small Diameter Wheel Compared to the Large Diameter Wheel	9
4. A Difference of Steel and Rubber Tired Wheels .....	10
5. Comparative Draft of Wide and Narrow Rubber Tires and of High and Low Inflation Pressures .....	12
6. Track Surface, Tire Width and Inflation Pressure All Play a Part in Tire Deformation.....	13
7. Three Types of Silage Carts Used in the Study .....	14
8. The Type of Wheel Used Partly Determines the Size, Height and Shape of Box.....	14
9. A View of the Under Side of the Silage Carts, Showing Framework and Wheel Suspension .....	15
10. An Extremely Light Utility Cart and the Conventional Barrel Cart	17
11. The Bicycle Wheel Cart with Wheel Removed .....	17
12. "A" Type House Mover.....	18
13. Birds Eye View of "A" Type House Mover.....	19
14. Procedure In Loading Portable House on "A" Type Mover.....	20
15. Plans For the "B" Type House Mover.....	22
16. The "B" Type House Mover.....	23
17. Steps in Loading the "B" Type House Mover .....	23
18. The Low Platform Trailer for Dispensing Feed and Water to Hogs on Pasture.....	25
19. The Low Platform Trailer for Hauling Machinery.....	25
20. A Large, Low Platform Trailer Built for Moving Heavy Machinery	27

# Homemade Rubber Tired Carts and Trailers

By Henry H. DeLong

## Introduction

There have been marked changes in machines of transportation since the advent of the pneumatic tire. Development of the automobile industry has given rubber tire manufacturers a great opportunity to make an article in mass production, improve its quality and lower its price. In turn the motor makers owe much to the rubber industry, for our modern automobiles would not be possible without the pneumatic tire.

The pneumatic tire greatly reduces shock and vibration in rapidly moving vehicles. The tire was employed on the early automobiles, bicycles and motorcycles for the purpose of reducing shock and providing riding comfort and longer life to the machine. With the development of greater speeds tires became a necessity, not merely a desirable article of equipment.

The truck was developed bringing a speedy vehicle for hauling to the larger farm operators. The smaller farm operators, of their own accord, began building trailers of old car parts to be used with their passenger automobiles. These two-wheeled and four-wheeled trailers were fairly well suited to a farmer's needs and were inexpensive. There were old car parts available and local mechanics could do the necessary cutting, welding and forging.

The primary purpose of the first trailers was to create a high speed vehicle for long distance hauling. Fortunately, the pneumatic tire allowed the load to roll more easily than an equal load on steel wheels under most conditions.<sup>1</sup> It was logical then for people to start using their four-wheeled trailers in place of the regular farm wagons. These homemade rubber tired wagon outfits proved superior to the conventional wagon in many respects and the farm implement manufacturers were not slow in supplying a factory-made vehicle.

Pneumatic tires were adapted to tractor use during the present decade. This fitted the tractor for high-speed road work and hauling. In some cases the high speeds made tires desirable on farm implements. In other cases where a machine was being adapted to small tractor use and light draft was necessary, the pneumatic tire contributed to lighter draft. At present the pneumatic tired wheel is commonly found on farm machines.

The project undertaken by the agricultural engineering department of the South Dakota Agricultural Experiment Station involved the study of several practical applications of used car parts and tires to farm vehicles. It was felt that there was a need for adapting tires to small push carts and feed carts and to specialized trailers. The study has been divided into two parts, with that part which deals with the small carts and specialty trailers being discussed in this bulletin.

---

1. Similar results are given in publications of the British Rubber Publicity Association.

Other experiment stations have made a study of wheel size and tire size and compared the draft of pneumatic tired wheels to steel wheels on wagons, tractors and a few other farm implements. The South Dakota Station has gathered data on these factors from the standpoint of very light loads and slow speeds, or from the standpoint of wheel application to light carts.

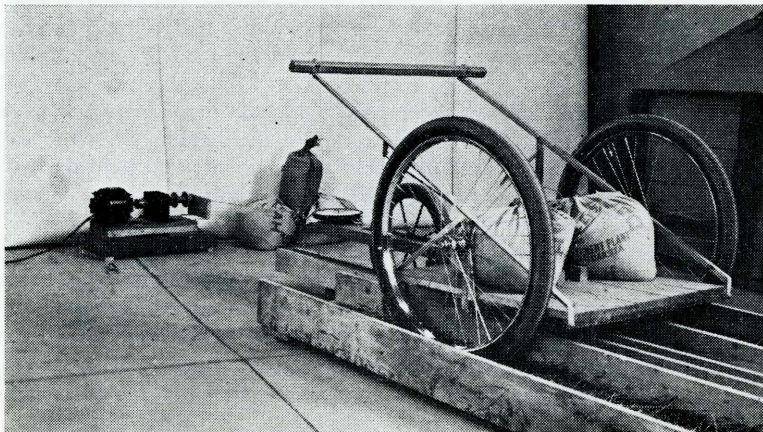
Information now is available as to the proper size and inflation of tire for a given load and speed. Inasmuch as the very light loads of push carts fall below any similar studies made, data have been gathered on different tire sizes and different inflation pressures and their effect upon the draft of carts. Wheel and tire size are also discussed from the standpoint of ease in securing used parts and tires. The findings of these tests are discussed in the first part of the bulletin.

The second part of the bulletin deals with the design of the various carts used in the study. The last part describes several specialized trailers to aid in brooder house and farrowing house moving, machinery hauling and feed transporting to individual hog lots.

### **Method of Testing the Draft of Carts**

Finding the best size of wheel and best type of tire for farm carts has been an important part of this study. Tests were run to determine which wheel type would give the lightest draft on a variety of surfaces.

Figure 1 shows the apparatus used. Two trough-like tracks were built and placed on a level floor. They could be set in or out to accommodate a narrow or wide tread. A narrow center track was used for a guide wheel.



**Fig. 1.** This apparatus was used to test the draft of the carts.

Loads were placed on the cart so that the cart was nearly balanced on its own wheels so that the guide wheel carried almost no load. A quarter horsepower electric motor coupled to a 50 to 1 gear reducing unit and windlass formed the motive power for the carts during the test. A very small pliable wire cable was made to wind up and pull the load. The average speed of travel for the carts was .140 feet per second. Due to the winding effect of the windlass the speed over the first 5 feet of track was .120 ft. per second; of the second 5 feet, .140 ft. per second and of the last 5 feet, .167 ft. per second. This gave a gradual acceleration of about .05 feet per second in a period of 107 seconds.

Three different spring scales were used for the tests, one recording a 5 pound maximum load and two which recorded 40 pound maximum loads. During each test an observer would record from 15 to 30 readings of the scale and these were then averaged. The result of one trial was found to agree closely with results of many subsequent trials so this method was continued throughout the test. However, those conducting the tests depended more on numerous repeated tests, rather than on trying to have an extremely accurate single test.

The different track surfaces used were: (1) Smooth boards, (2) A three inch layer of soft, fine, dry dirt, (3) A three inch layer of coarse gravel from  $\frac{1}{4}$ -inch to  $\frac{3}{4}$ -inch size, and (4) A smooth board track with alfalfa hay placed upon it. The track materials used were kept uniform for a whole series of tests. After each trial the soft dirt tracks and the gravel tracks were scarified and releveled. The hay-covered board tracks were hardset to keep uniform, and results from these tests are not used in the tables.

The starting force, and sometimes the maximum pull, were recorded for each test. However, the force needed to start a load and accelerate it depends largely on the speed with which it is accelerated. With carts, the operator is at liberty to start slowly so the main concern of the study was that of finding the force necessary to overcome rolling resistance of the wheels. The slow speeds were chosen to facilitate reading the scale accurately and to minimize the affects of acceleration and deceleration due to small obstacles along the tracks.

Small irregularities in the track caused fluctuations in the scale. The observer would record readings when the scale indicator remained steady and would record mid-point readings between maximum and minimum fluctuations of the scale indicator. Six different carts and eight different sets of wheels were tested on four kinds of track surfaces. From two to five variations of loads were tried for each wheel type. All pneumatic tires were tested for each load and track condition with two or three changes in inflation pressure. Over 300 tests were run, each consisting on an average from two to four trials.





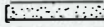
	Force Required To Pull 100 lbs. of Load.			
	5	10	15	20
 smooth board track  gravel track  fine dry dirt				
Small steel wheel 13x2 Light load	2.12			19.24
				20+
Large steel wheel 36x2 Light load	3.75		10.04	
		7.30		
Small steel wheel 13x2 Heavy load	2.20		18.0	20+
Large steel wheel 36x2 Heavy load	2.88		11.92	11.90
Small rubber tire 4x8 Light load Pressure 30	1.25		11.90	15.40
Large rubber tire 21x4.50 Light load Pressure 30	.71	6.74		4.78
Small rubber tire 4x8 Heavy load Pressure 30	1.39	10.00		12.50
Large rubber tire 21x4.50 Heavy load Pressure 30	.84	4.90		4.25
	5	10	15	20

Fig. 2. Comparative draft of large and small wheels, and of steel vs. rubber tired wheels.

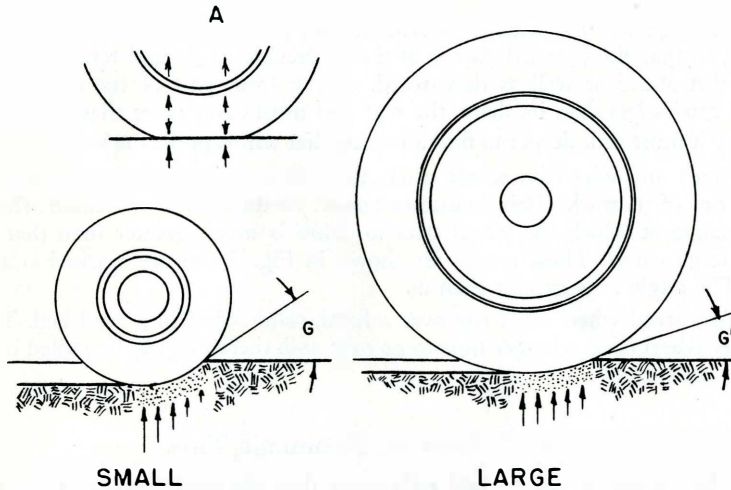


Fig. 3 The small diameter wheel compared to the large diameter wheel.

The large diameter wheel has a longer supporting area, sinks into soft ground less and rolls easier under most conditions.

### Relation of Diameter of Wheel to Draft

Tests proved that wheels of 26- to 36-inch diameter gave less draft than wheels of 13- to 16-inch diameter in most cases. On a smooth, hard level floor the small steel wheel rolled as easily as a larger wheel, providing that there were no lugs or spokes to make the rims rough. With all rubber tires and with all track conditions, other than the one just mentioned, the large diameter wheel was superior.<sup>2</sup> The bar graphs in Fig. 2 show plainly the lighter draft for the larger wheel, under varying conditions.

The diagrams in Fig. 3 show graphically some of the reasons why the small wheel requires a greater force to move a given load supported by it. When a pneumatic tire comes in contact with a smooth hard track as shown in "A," Fig 3, the tire adjusts its shape to carry the load. The area in contact with the track times the inflation pressure per unit area, will equal the load carried by the wheel, neglecting the resistance of the tire casing to bending. On soft surfaces two adjustments have to be made. The soft road bed settles and packs to the extent that it will support the load, and the tire adjusts its surface to a more complex supporting area, not all of which bears upward with the same force.

2. Tests with wagons at the Missouri Station and tests with various kinds of steel and pneumatic tires for farm implements and tractors at the Iowa Station resulted in the same conclusions.

The smaller tire, with its shorter radius, has a less efficient supporting area, in that the forward part is at a considerable angle and tends to force the dirt ahead as well as downward. As the front part of the supporting area carries less than its share, the rear part must carry more than its share; hence it must sink deeper to find a footing that will support the load.

With any wheel on a soft track, there is a tendency for the wheel to rise out of its track. This consumes power. In the case of the small wheel, the angle at which the wheel tries to climb is much greater than that of the large wheel. These angles are shown in Fig. 3 and are marked  $a_1$  and  $a_2$ . The angle  $a_1$  is greater than  $a_2$ .

Any sized wheel must rise over a fixed, solid object in a road bed. The larger wheel takes a longer time to go over and, therefore, can be pulled over with less force.

### Steel Wheels vs. Pneumatic Tires

The pneumatic tired wheel rolls easier than the steel wheel of the same diameter in practically all cases. The most noticeable difference is on rough or soft surfaces.

This conclusion scarcely needs proof as it is well understood. After running tests to find the effect of wheel size and tire cross-section, it took only a short time to put the test results together in such a way as to compare the steel wheel and the pneumatic tire.

The bar graphs in Fig. 2 show that pneumatic tired wheels have the least draft. The diagrams in Fig. 4 show how the steel wheel is forced to "rise"

3. Tests with tractor wheels and implement wheels at the Ohio Station and at the Iowa Station show the same conclusion for wheels carrying heavier loads.

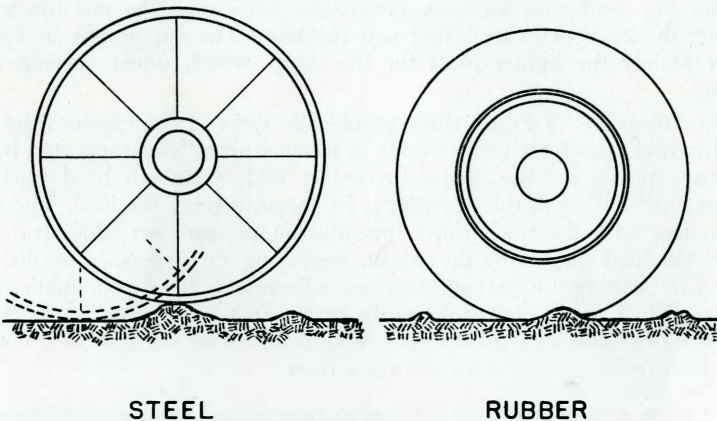


Fig. 4. On all rough surfaces, pneumatic tires flow over small obstacles, while steel wheels rise over them.

over small obstacles while the tire has a tendency to "flow" over any object with less area than that part of the tire in contact with the ground.

Steel wheels used in this test were of three sizes: 13 inches, 30½ inches and 36 inches in their respective diameters with each having a 2 inch rim. The pneumatic tired wheels carried tires of the following respective sizes: 4-8; 26-2.125; 30-3.50; 21-4.50; and 6-16.

### **Inflation Pressure of Cart Tires**

On all tires except the bicycle tire the high inflation pressure was taken as 30 pounds per square inch with a low pressure of 7 pounds. The high pressures gave very little deflection with a load of 500 pounds. The bicycle wheel's high pressure was its recommended pressure of 22 pounds per square inch, while 11 pounds seemed to be the lowest practical pressure to use.

In the bar graphs of Fig. 5 test results representing high and low pressures are shown. These tests show in every case that the high inflation pressure is best for every wheel type on hard, smooth surfaces. There is less deformation of the tire and less friction as a result of bending the tire wall.

On rough tracks and on soft tracks, for every wheel type and tire size, the low inflation allows the load to roll more easily. The added tire wall bending, due to low pressures, is more than overcome by the larger supporting area of the low inflated tire and its ability to "flow" over small obstructions more easily than the high inflated tire.

### **Effect of Load Size on Pneumatic Tire Width**

The determining factor of tire size, or cross-section, is the load it is intended to carry. In automobile and truck tires extra sizes must be added as a factor of safety, because of high speeds, high internal heat and larger braking surfaces. None of these problems enter into the picture with farm carts.

From the standpoint of hand carts, a load of 300 pounds per wheel is all that is desirable to carry on any but a smooth, hard surface. Loads heavier than 600 pounds on a hand cart are difficult for one person to handle on uneven surfaces. All of the tires used, supported a 600 pound load easily, with the exception of the 26-2.125 size which should not carry more than 150 pounds per wheel. Any tire for cart service need not be larger in cross-section than 3½ or 4 inches. However, a larger tire, such as a 6-16, has no disadvantages except the added width makes for a wider cart.

The bar graphs of Fig. 5 show the draft of five different kinds of tires of various cross-sectional sizes. The tests were run at both high and low inflation pressures and on smooth board and soft dirt tracks. On the smooth tracks there is little difference between the draft of the narrow pneumatic tires and the wide ones when the same load is carried. It must be kept in mind that these loads are far below those intended for the tire in all cases, except for the bicycle tire. The small cross-section tires pulled slightly heavier on soft tracks than did the wider tires.



		Force Needed To Pull 100 lbs. of Load.			
		5	10	15	20
 smooth board track					
 fine dry dirt track					
Wheel barrow tire 4 x 8	High pressure 30 lbs	1.39			
			12.5		
Wheel barrow tire 4 x 8	Low pressure 7 lbs	3.99			
			7.80		
Bicycle tire 26 x 2.125	High pressure 22 lbs	.81			
			6.34		
Bicycle tire 26 x 2.125	Low pressure 11 lbs	1.22			
			5.56		
Car tire 30 x 3.5	High pressure 30 lbs	1.31			
			7.34		
Car tire 30 x 3.5	Low pressure 7 lbs	2.34			
			5.37		
Car tire 21 x 4.50	High pressure 30 lbs	.84			
			4.25		
Car tire 21 x 4.50	Low pressure 7 lbs	1.65			
			3.89		
Car tire 6 x 16	High pressure 30 lbs	.94			
			5.11		
Car tire 6 x 16	Low pressure 7 lbs	1.89			
			4.50		
		5	10	15	20

Fig. 5. Comparative draft of wide and narrow rubber tires, and of high and low inflation pressures.

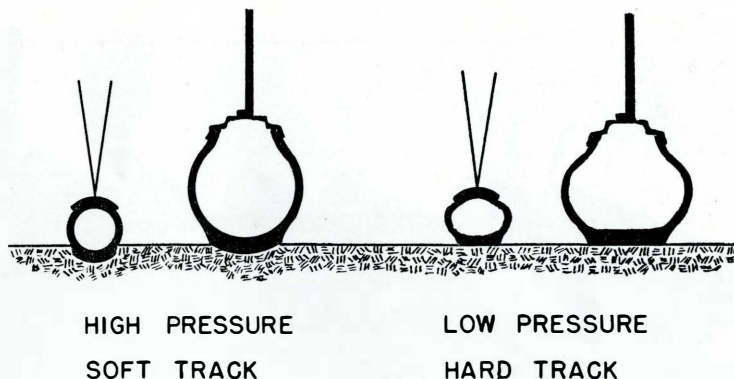


Fig. 6. Track surface, tire width and inflation pressure all play a part in tire deformation.

Under high pressures and on soft tracks, the small tire will sink farther and make the deeper track, and the supporting surface is curved. At low pressures and on hard tracks the small tire side walls receive much greater bending.

In Fig. 6, diagrams show the effects of tire size on two different surfaces. If a narrow tire and a wide tire, each with the same high inflation pressure, are placed on a soft track the small tire will sink in more and cause a greater draft. When a narrow tire and a wide tire, each with the same low inflation, are placed on a hard surface each tire will adjust its contact area to carry the load. The small tire being narrower must sink farther to get this area, thus causing a serious bending of the side walls. Excessive bending is hard on the tire fabric. The narrow tire, if run under these conditions, would be shorter lived than the wider tire even though the draft of the two varied only a small amount.

### The Design of Silage Carts

The silage cart was chosen as a type on which to try out wheel and tire size. The silage cart is a very useful article on any dairy farm where silage is fed. Fig. 7 shows the three types of carts built and studied. There was no attempt made to build a perfect cart in design nor workmanship, but rather to build a cart with one or more distinctive features that could be tried out and studied. All three carts have about the same capacity and all were made to go through a 36 inch door. All boxes were made of 1x6 inch pine flooring, braced with 1x4 inch, 1x2 inch wood braces or angle iron.

Exact plans for these carts are not given in this bulletin as old car parts were used in most of them. There is a variety of used car parts, and a plan drawn to fit one type of wheel might not be suitable for some other which was at hand. Three views of each cart are shown with the hope that the general idea of each type can be seen. The advantages and disadvantages of each type will be discussed.

The utilization of old automobile parts was a major purpose of the study. However, to make the study of wheel size more complete, silage cart A was

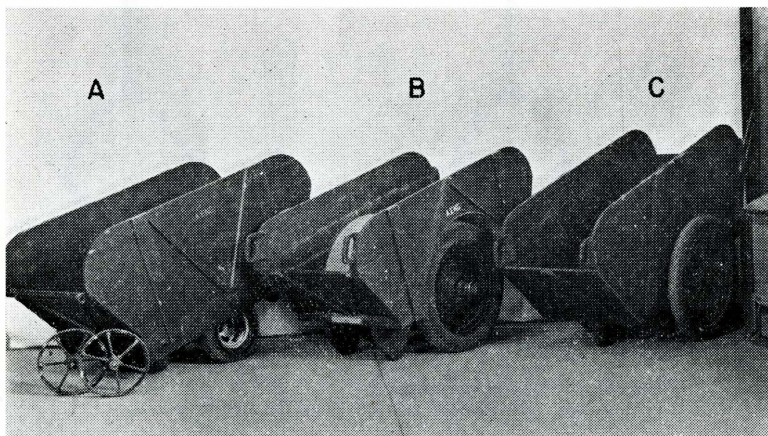


Fig. 7. Three types of silage carts used in the study.

equipped with a set of wheels having a 4:00-8 tire. These wheels are similar to the ones which are placed on wheelbarrows. The wheel is of the roller bearing type with drop-center rims and the tire has an inner tube. The small 13 inch diameter steel wheels (A) Fig. 7 could also be placed on the cart. They were also mounted on roller bearings.

Silage cart B was built on a set of 1928 Chevrolet front wheels with their 21-4.50 tires and their own steering knuckles as axles. These axles also accommodated a pair of similar wheels whose steel discs had been cut down and a

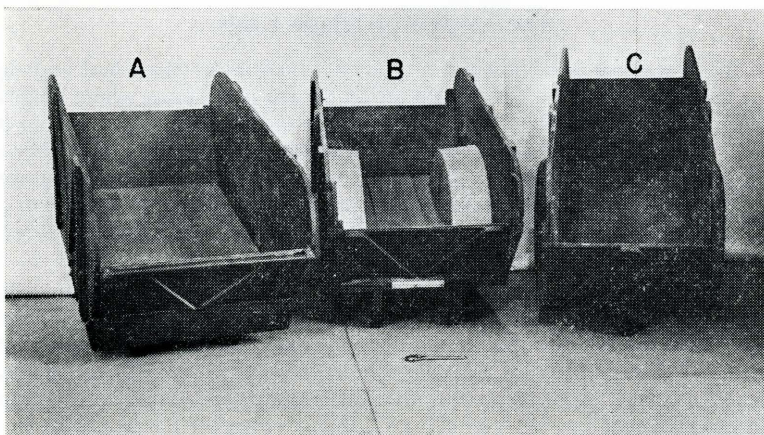


Fig. 8. The type of wheel used partially determines the size, height and shape of the box.

6-16 drop-center rim welded on. The tire, hub cap and bearings on these wheels take up considerable space. In order to keep the width less than 36 inches, wheel fenders had to be built into the inside of the box. Cart B Fig. 8 shows this more plainly. Although there is still room for a large silage scoop between these wheel fenders, they do take up considerable room and cut down on the capacity of the cart. The wheel itself gives very fine service.

Silage cart C has a longer and narrower box than the other two, and therefore has room outside of the box for the narrow 30-3.50 tires and the rear wheels of a Model T Ford car. The rear wheel of this car must be used rather than the front wheel which has a protruding hub cap, which would make the cart more than 36 inches wide.

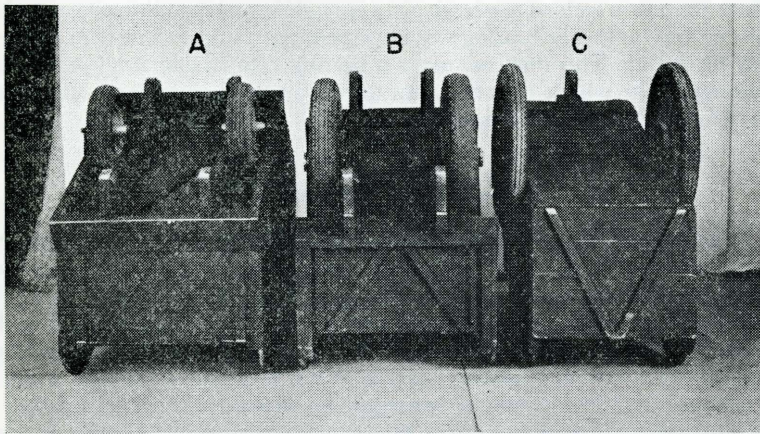


Fig. 9. A view of the under side of the silage carts, showing framework and wheel suspension.

Table 1. Advantages and Disadvantages of the Three Types of Silage Carts

	Advantages	Disadvantages
Cart A	Low set box—convenient Small wheels—under cart Low axle or pivot point	No second hand wheels or tires available Harder to push than carts with larger wheels More complicated frame needed
Cart B	Used car wheels available Large wheels that roll easily Wheel (if disk type) can be cut down to 6-16 tire size.	Few second hand 21-4.50 casings available Wheel fenders in box necessary due to wide bearing
Cart C	A few used parts still available. Narrow wheel and tire eliminates wheel fenders in cart. Simplest to build—fewest parts	Few second hand casings and tubes available in 30-3.50 Plain wheel bearing instead of roller or ball bearing



Silage carts A, B and C are shown again in Fig. 9. This picture shows how the bottom framework is made and how the wheels are suspended. The small wheel in cart A must be mounted on both axle ends and a wide piece of strap iron extended downward from the 2 x 6 inch framework.

Cart B shows the framework necessary to support the steering knuckle type of axle. The two 2 x 6 inch main frames which run lengthwise had to be braced with two short pieces of 2 x 6 inch laid crosswise. The two main frames were kept from twisting by placing a long bolt from one to the other, near each of the shorter 2 x 6 inch cross pieces.

Cart C is the simplest of all but does not have the ball or roller bearings as the others. A welder cut two rear axle shafts, to which the rear wheel was originally bolted, so that their combined length came under the 36 inch limit. These were then welded to a large piece of angle iron. Upon this axle assembly the cart was built. The bearing was the tapered part of the shaft with the keyway turned up. This does not make a bearing comparable at all to the ball bearings of the wheels in cart B, but they seem good enough for silage cart service if they are oiled occasionally.

### The Light Utility Cart

The two carts shown in Fig. 10 are of the lighter type for general barnyard work. The cart marked "E" is the conventional barrel cart which has been made for years and can be purchased today as shown or equipped with a light wheel and automobile tire. This cart had the 36 inch steel wheel used in the tests. It was not thought practical to purchase a set of wheels that would accommodate a 4:00-36 implement tire, as this size of wheel and tire is not in general use and there would be practically no second-hand parts available.

The light cart marked "D" in Fig. 10 was an attempt to make the very lightest kind of a utility cart and to determine if it would be useful and practical. The platform was of 1 inch lumber, the axle of heavy angle iron and 1 inch square rods welded together, the frame of light angle iron, and the wheels of 26-2.125 bicycle fronts. The platform, axle and wheels appeared to be strong enough to support a 500 pound load, but the 26-2.125 tires should not be loaded with more than a 300 pound load. The cart alone weighs 50 pounds. Due to the lightness of the cart itself, the force needed to move a load was extremely low. However, on a basis of the force required to move a hundred pounds of load, it has not proved as efficient as the larger tires on soft tracks with heavy loads.

This cart could be used for carrying a 30 gallon barrel, two or three 10-gallon cans, a few sacks of feed or similar jobs. The tires did not hold their inflation pressure at 22 pounds per square inch for any length of time and needed more attention than the larger tires from that angle.

As the picture in Fig. 11 shows, the bicycle wheel was mounted from one end only, instead of from both ends of its axle. Trials indicated that the original axle bolt was not strong enough when mounted from one end. For this purpose a special bicycle wheel had to be purchased. This special wheel

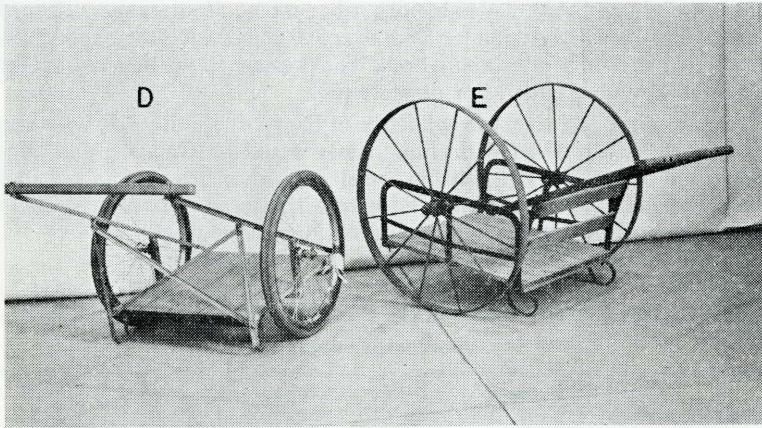


Fig. 10. An extremely light utility cart and the conventional steel wheeled barrel cart.

was the front wheel with brake hub. After removing one of the small ball bearings, the brake parts and the entire spindle, the spindle part was replaced with a piece of  $\frac{1}{2}$  inch steel rod threaded to  $\frac{1}{2}$  inch standard fine threads on the supporting end and cut down and threaded to 5-16 inch on the outside end to carry the original ball bearing race. Fig. 11 shows the construction.

The drop-center rim and the tire with replaceable tube was selected in preference to the single tube tire. Although the bicycle wheel cart was very

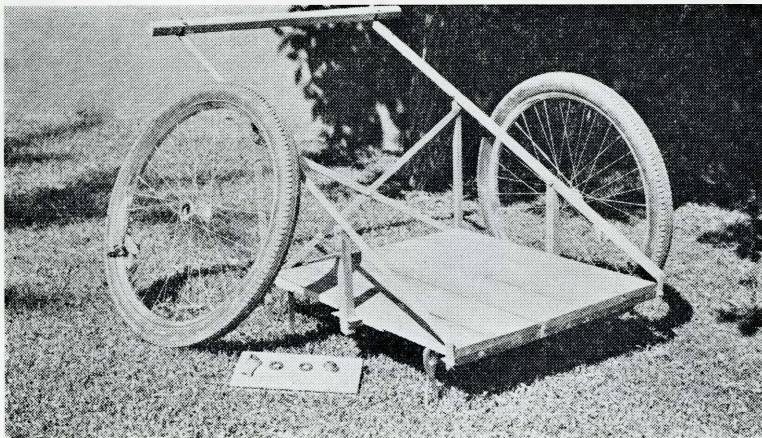


Fig. 11. The bicycle wheel cart with wheel removed. Brake arm "b" fits on  $\frac{1}{2}$ " shaft and forms inner bearing cone. The outer bearing cone is not changed.

light in weight and very easy to handle, it had a few disadvantages. The tires were too small in cross-section for loads over 300 pounds. It was not possible to get second-hand tires, tubes and wheels. The pressure in the tires did not stay up as well as with a larger, low pressure tire.

A more practical barrel cart would be of the type "E," Fig. 10, with automobile wheels. Second-hand tires and tubes would be available, and larger loads could be carried. By reducing the size of wheel from 36 inches to 30 inches, the ability to carry a tall slender load is reduced. Tall barrels filled to the top would be top heavy and would not balance as well.

Table 2. Brief Specifications of the Carts Used in the Study of Wheel Sizes and Types

Overall Dimensions	Silage Cart "A"	Silage Cart "B"	Silage Cart "C"	Bicycle Wheel Cart	Barrel Cart
Length—inches	69	70	78	46	34
Width—inches	34	34	35	35	41
Height—inches	42	42	45	33	36
Weight—pounds	208	292	191	49	96
Height of Floor—inches	18	18	17	8	9
Size of Floor—inches	32x50	32x50*	25x54	28x25	29x25½
Wheel Type	Pneumatic Wheel Barrow	Automobile Wheel	Automobile Wheel	Bicycle Wheel	Steel Wheel
Wheel Size—inches	4-8	21-4.50	30-3.50	26-2.125	36-2
Bearing	Roller	Ball	Plain	Ball	Plain

\* Minus space of wheel houses

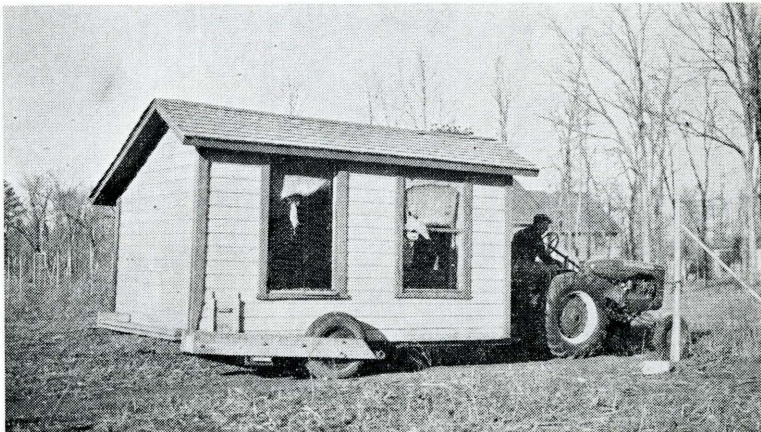


Fig. 12. The "A" type house-mover. Carries the building easily without wracking it, and without cutting up yards and lanes.

## Type "A" Trailer for Moving Brooder and Farrowing Houses

A specialized trailer to move brooder houses and farrowing houses was built. Such a trailer was made to aid in a program of clean pasture lots for chickens, turkeys and hogs. In order to keep livestock on clean pastures, small shelters must be used and these must be moved often—at least annually. If for any reason, the shelter is not moved and the young livestock left on contaminated ground, the benefit of the entire system is lost. The purpose of building a brooder house and farrowing house mover was to make the mechanics of moving these buildings easy, quick and without damage to the buildings and yards.

The common method of moving was by pulling the brooder houses on skids. No method could be simpler in principle or take less equipment. However, much power was required, the house was often wracked and twisted and it was often hard to guide the house through gates and lanes. The built-in skids, oftentimes rotted or the cleavages pulled out. Yards, fields or lanes were sometimes badly cut up.

With the faults of the skid method in mind, equipment for moving brooder houses and farrowing houses on wheels—pneumatic tired in these trials—was built. These machines were named house-mover "A" and house-mover "B" and are referred to by that name in this bulletin. They were built only for the moving of light buildings such as brooder houses and farrowing houses. Type "A," shown in Fig. 12, moved the brooder houses with the power of one horse or a small tractor without cutting up yards and lanes. Best of all it did not twist the house and wrack its framework.

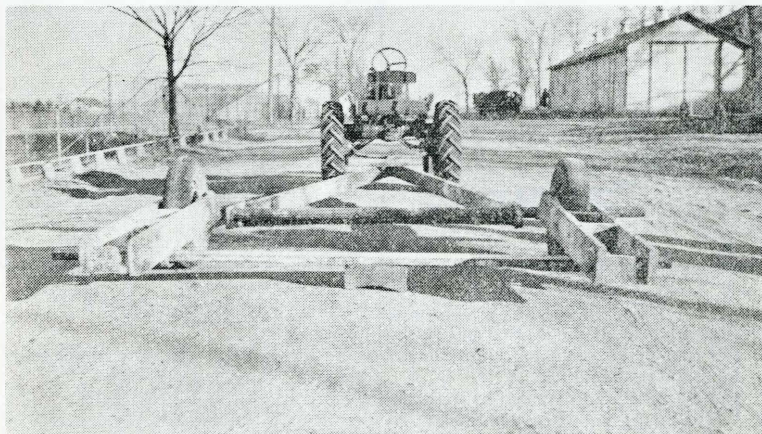


Fig. 13. Birds-Eye View of "A" type house-mover.

The mover parts are assembled in the positions they would take when carrying a house.

The House-Mover "A" required about \$25 worth of material, forge work and wheels. The wheel type used was the old disc type car front wheel and steering knuckle with the old rim removed and a 6-16 drop-center rim welded on. A tire of this size was really needed to support the load that the cart had to carry. An 11-foot piece of 2½ inch pipe was the main supporting member under the house and this allowed the cart to carry a brooder house of 8 feet in width, and still permitting the trailer to pass through a 12 foot gate. Each wheel was mounted on a

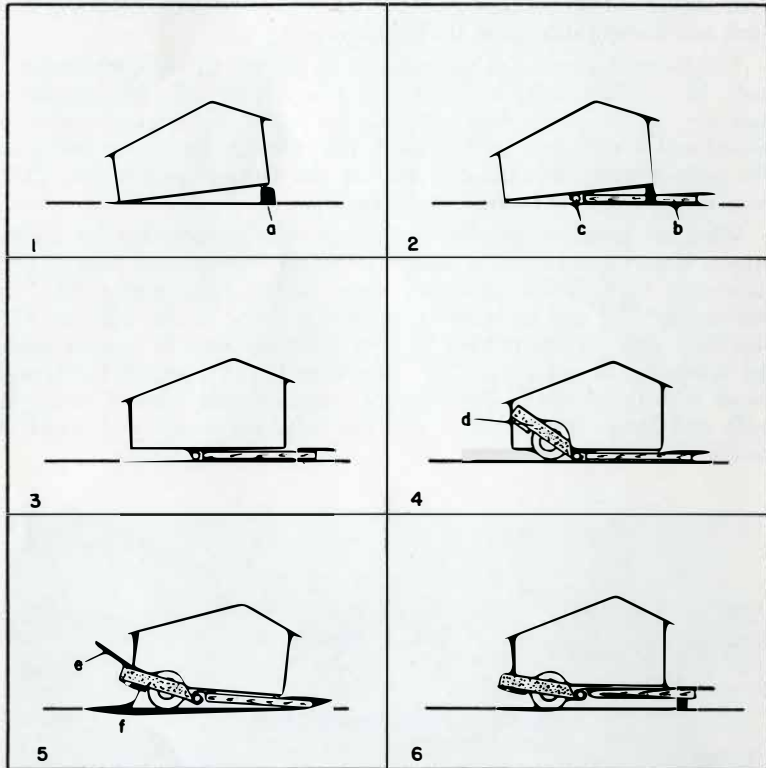


Fig. 14. Procedure in loading portable house on "A" type mover.

1. One end of the house is lifted and blocked up at "a."
2. The triangle "b" is placed under the house and the pipe "c" placed under the triangle and in the hooks.
3. The block "a" can now be removed and the house let down on the triangle.
4. A lifting gang and wheel "d" is hooked under the pipe on either side.
5. Extension lever "e" helps operator to raise house until a 2 x 8 inch plank can be placed at "f" from one gang to the other.
6. The wheels carry most of the weight. The tongue can be raised to the tractor draw-bar height.

lifting gang. A birds-eye view of the type "A" is shown in Fig. 13 to give the position of the parts when it is under the brooder house. Exact plans are not shown as the individual making the carrier might have a special sized house in mind, or have a particular type of automobile wheel which he wished to use. Blue prints of this mover can be secured by writing to the South Dakota Agricultural Experiment Station.

The procedure in loading a brooder house on a carrier of this kind is shown in the series of sketches in Fig. 14. A crew of three men can operate the outfit easily without hard work or loss of time. At the State College Poultry Department nine brooder houses were moved in 3 hours, each going about a quarter of a mile. Those who have used this method as well as that of dragging the houses on skids, heartily recommend the former.

### **Type "B" Trailer for Moving Brooder and Farrowing Houses**

A second type of brooder house and farrowing house trailer which is called the "House-Mover B type" was designed to have a mover that could be operated by one man. The plan is shown in Fig. 15.

The machine is extremely simple in that it consisted of an old automobile front axle lengthened out and an "A" shaped frame and pole. This house mover was to be used on buildings of 7-foot, 8-foot and 10-foot widths. This gave an opportunity to build and try out a telescoping axle—one which could be set for different widths of buildings. Type A also had this adjustment. If the wheels and axle had been built non-adjustable and yet wide enough for the 10-foot houses, two difficulties would have arisen: (1) The extremely wide set wheels would have been hard to get through gates, and (2) If a heavy narrow load were placed on the center of the long axle, a very strong axle would be required.

The front axle of a light car was used in this trailer. The disk wheels were cut down to accommodate a drop-center rim and a 6-16 tire. When the rims were welded on, the mechanic also welded the steering knuckles solid so the wheels would not turn. The cutting torch was used to cut the axle in two in the center. A 36-inch piece of 3-inch pipe was then bolted to each half axle. A 5-foot piece of 2½ inch pipe was then placed inside of the two 3-inch pipes, making the axle into a telescoping, or adjustable one. The narrowest setting was for a 6-foot building. With the 5-foot center pipe the width could be safely extended to 9 feet. A longer center pipe is recommended for a building 10 feet wide.

One-half inch U-bolts were used to fasten the 3-inch pipes to the car axle. Welding at these places might be used in addition to the U-bolts. If welding is done, care should be taken not to deform the shape of the large pipe; otherwise the smaller pipe will not move in it freely.

The tongue and frame construction are shown in Fig. 16. The "A" shaped part was made of old automobile frame members of the kind that are straight for their entire length. These were about 8 feet in length. A tongue of 2½ inch pipe extended an additional 3 feet from the frame. Other materials and other dimensions may be used. These are but suggestions that

have proved to be strong enough for the work. The two angle irons which form the bar across the "A" shaped frame must be made to allow this frame to spread out as the axle is widened. This can be done by several sets of holds in the angles and frame, one set of each position. A sliding arrangement, however, is an advantage, and was used for the machine designed by the South Dakota Station.

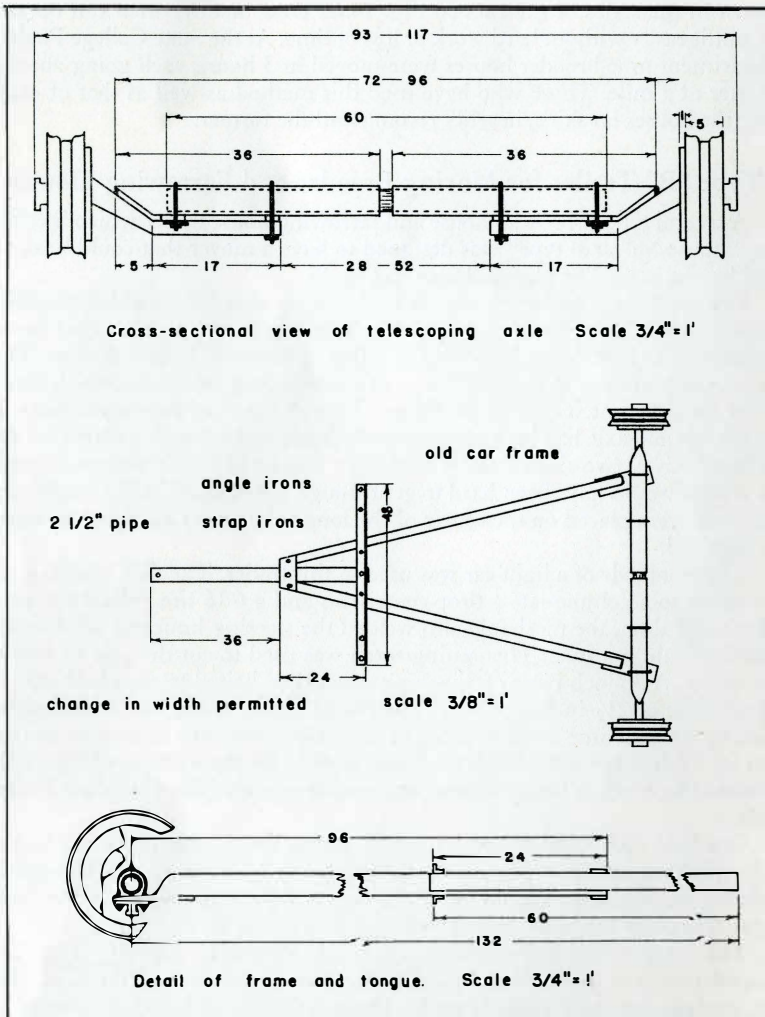


Fig. 15. Plans for the "B" type house-mover.

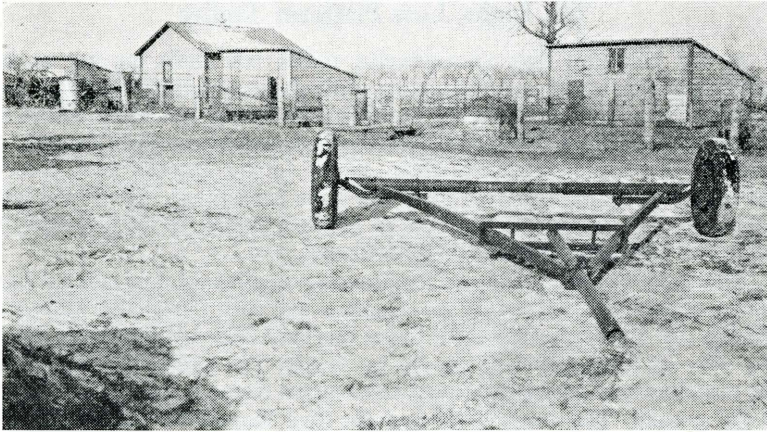


Fig. 16. The "B" type house-mover.

Steps in loading a house on this mover are shown in Fig. 17. Four large blocks, or a larger number of small blocks, are needed. If one man is to operate the mover, a farm lever jack is needed—one that has a lift of 4 feet or more. These jacks are not expensive and can be used for many other things, such as stretching wire. The procedure should be similar to the following steps:

1. Use jack "a", to lift one end of brooder house and put blocks under each corner of that end, as at "b" in the left hand figure.
2. Use jack to lift the other end and place blocks, not under corners, but very close to the center of the house "c", so that it will just balance.
3. Remove jack and push trailer under the building, the tongue going first and between the blocks "d". The axle should go up to the blocks "c".
4. Use jack to lift the house enough to remove block "c" and the building will then rest on the axle of the trailer.
5. Attach tractor to tongue and use jack to remove blocks at "b".
6. Unloading the house is the same as steps from 1 to 5 inclusive, but reversed.

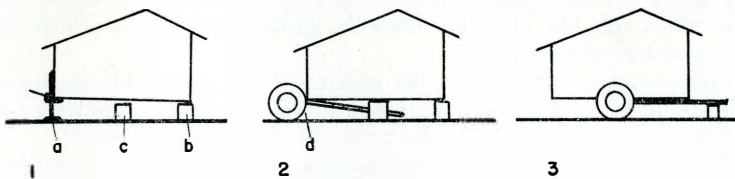


Fig. 17. Steps in loading the "B" type house-mover.



## The Light, Low Platform Trailer

A low platform, light four-wheeled trailer was built for use at the college hog farm. Each summer, many of the hogs are placed on temporary pasture at some distance from the buildings. Both feed and water had to be trucked to these hogs. The use of the stoneboat and barrel was slow and required many trips. Water was often spilled on the bags of feed. Transferring water by buckets was hard and time consuming. The trailer and wagon box was better, yet feed had to be lifted higher in loading and the water still had to be transferred by buckets.

The staffs of the agricultural engineering department and animal husbandry department decided on specifications that such a feed and water dispensing cart should have and the trailer was built. The two front axles of old cars were used together with an old car frame. The front axles with their low clearance and springs removed allowed the frame to be mounted close to the ground. The frame used had the two longitudinal members perfectly straight. This was a decided advantage in making a full, low platform. This type of frame was very hard to get as most of the old frames have a raised portion over the rear axle.

A plank floor was laid directly on the straight steel frame, and bolted to it. There were nearly enough holes in the frame to bolt down every plank. Drilling on this type of material is almost impossible with average farm tools and the cutting off of rivets on car frames is equally hard. One must use ingenuity in fitting the parts together to take advantage of natural bends, braces and holes. The frame was fastened to the axles, front and rear, by U-bolts, and later arc-welded.

The rear set of wheels had all of the steering rods removed and then each wheel was welded rigid. A commercial trailer tongue and steering unit was purchased and clamped to the front axle. The tongue was removed and the trailer equipped for a one-horse outfit.

The platform was made 66 inches wide except the part between the rear wheels which was 40 inches wide and a small platform between the front wheels on which the driver could stand. Strap iron bands were placed along the side edges to prevent scuffing and to equalize the weight on all boards.

Fig. 18 shows the trailer equipped with a sack rack in front and an elevated tank in the rear. Hog waterers could be filled by gravity from the high tank and it in turn could be filled from the water mains or pump, eliminating any hand labor. Sacks of feed were loaded easily on the platform which was but 14 inches from the ground. All wooden parts were given a coat of creosote paint.

Both the elevated tank and the sack rack were removable so that the trailer could be used for other purposes. It was found to be handy in hauling hogs in crates and carrying the front end of the house-mover.

This same type of trailer, if built heavier, could be used as a machinery moving trailer. Fig. 19 shows the trailer carrying a corn planter. This

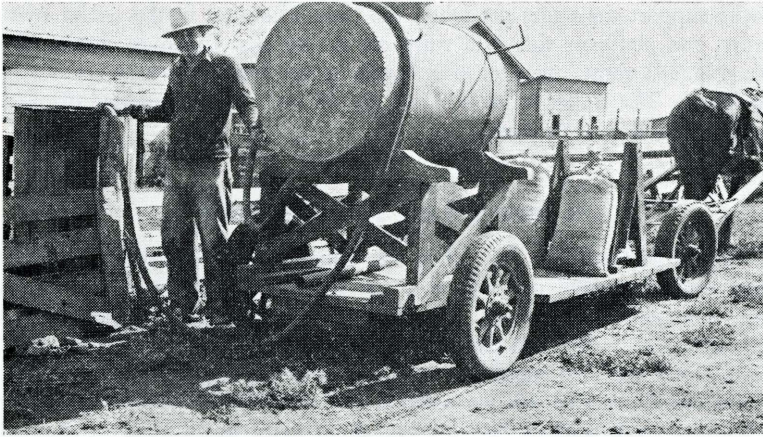


Fig. 18. A low platform trailer built for dispensing feed and water to hogs on temporary pasture.

machine could have been rolled up the tracks and loaded by one man. Such machines, though steel wheeled, can be transported this way behind cars or high speed tractors without loss of time or danger of harming the machine.

If heavier machines are to be transported, a stronger platform edge should be built. Also, blocks should be placed under this edge if a tractor is driven over, or a very heavy machine is pulled over the edge. The blocks are shown in "A" in Fig. 19. As a load goes onto the trailer side these

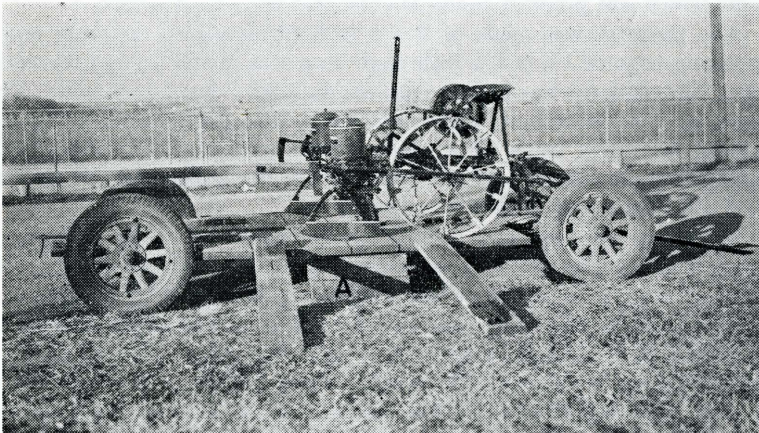


Fig. 19. The low platform trailer is useful in hauling machinery.

blocks support the edge; yet when the load is located in the center of the trailer, the platform side will raise off the blocks. Colorado Station Bulletin No. 443 shows pictures of a similar trailer built especially for moving machinery. The trailer illustrated in Figs. 18 and 19 was intended primarily for a feed and water trailer.

### **A Heavy, Low Platform Trailer**

The large trailer in Fig. 20 is one which the agricultural engineering department has tried out several years. It is used principally for moving heavy machines and tractors. Formerly, when the tractors had steel wheels and lugs, this trailer was particularly useful in moving them over paved roads, along graveled highways or to and from the fields. The rubber tired tractor has eliminated this necessity. It is still used for many purposes such as hauling track tractors, hay loaders, disks, brick and tile, and sometimes livestock in portable pens.

Narrow machines can be easily loaded. However, it is not easy to load more than one disk harrow on the platform, as the second disk has to be lifted over a rear wheel. For such a load, tilting-platform trailer would be much handier. The trailer has no springs, front or rear, and is suited to slow or moderate speeds.

The framework of this particular trailer was made very heavy. Four pieces of 5 x 1 $\frac{3}{4}$  inch channel steel beams formed the lengthwise framework. Two of these are back to back along the middle with one on each side. Five 5 x 1 $\frac{3}{4}$  inch channel pieces were welded to the outer and central channels forming the crosswise framework. This made an all-welded, rigid frame which was perfectly sound after several years hard service.

The platform was made of 2 x 8 inch plank placed crosswise and a protecting edge of 1 $\frac{3}{4}$  x 1 $\frac{3}{4}$  inch angle iron was placed around the entire edge. The platform was 12 feet 4 inches long and 7 feet 1 inch wide. This made the rear wheels of very wide width, but gave the trailer greater stability for heavy loads. The front wheels were standard width tread, mounted on an old car axle and connected to the trailer body by two old car front axles acting as cantilever beams.

The front tire size was 5.25-21 which proved to be an unfortunate selection in that almost no second-hand tires are now available in that size. The rear tire size was 32-6 and the wheels were from an old truck front axle. The brake drum protecting plate was flat and of a type which allowed the bolting on of a rectangular piece of  $\frac{1}{2}$  inch steel plate. This in turn was bolted to the side channel. The welded frame served as the remainder of the axle. The rear wheels could be placed in three locations along the side to carry more or less of the load and this made it more convenient for loading certain machines.

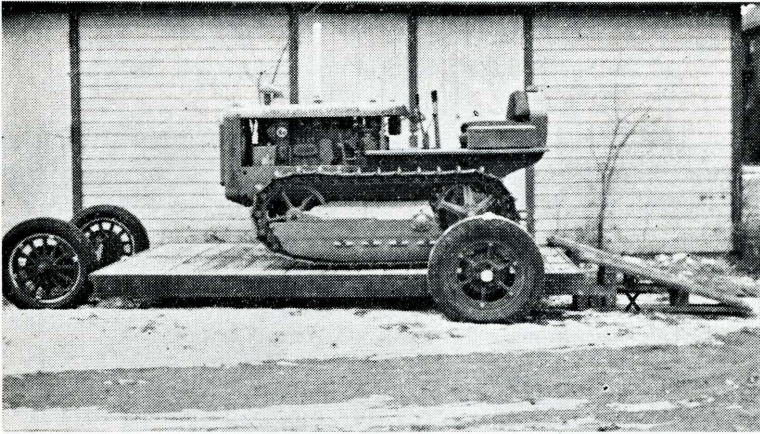


Fig. 20. A large, low platform trailer built for the moving of heavy machinery.

In Fig. 20 the letter x indicates the triangular loading approach or track. These had a ledge that fits in under the frame of the trailer edge and prevented the trailer from tipping up, when a heavy machine was driven onto the edge. Serious tipping of the platform would otherwise occur. It is necessary, but sometimes not convenient, to carry along these loading approaches.

### List of References

- J. BROWNLEY DAVIDSON, EDGAR V. COLLINS, EUGENE G. MCKIBBEN—*Tractive Efficiency of the Farm Tractor*, Research Bulletin No. 189, 1935, Iowa Agricultural Experiment Station, Ames, Iowa
- G. W. MCCUEN AND E. A. SILVER—*Rubber Tired Equipment for Farm Machinery*, Ohio Agricultural Experiment Station, 1935, Columbus, Ohio.
- ALEXANDER HAY, WARREN S. LOCKWOOD, D. M. MCHARDY, L. A. TRAMP, J. B. PASSMORE, M. H. R. SOPER AND A. POLDERVAART—*Rubber and Agriculture*, series of bulletins by the British Rubber Publicity Association, Bulletin Nos. 1, 2, 3, 4, 8, 9, 10, 11, 12 and specials, 1936-39
- E. G. MCKIBBEN, H. J. THOMPSON, J. BROWNLEY DAVIDSON—*Transport Wheels for Agricultural Machines*, I & II, Vol. 20, Nos. 11 and 12, Journal of the American Society of Agricultural Engineers, 1939
- J. C. WOOLEY, M. M. HONES, B. T. I. MAIRS, H. J. WATERS—*Draft of Farm Wagons and Study of Wheel and Tire Sizes*, Bulletin Nos. 237, 52 and 39, Agricultural Experiment Station, Columbia, Mo., 1925, 1901 and 1897
- WILLIAM P. KINTZLEY—*Home-Made Farm Equipment*, Colorado Agricultural Experiment Station Bulletin No. 443, 1938, Fort Collins, Colo.

# Available Bulletins

of the South Dakota Agricultural Experiment Station

As of March 1, 1940

Any of the following publications may be obtained free of charge by addressing a request to the Director, Experiment Station, Brookings, South Dakota. Please give both Title and Bulletin Number in ordering.

## AGRICULTURAL ECONOMICS

- 225 Farm Production and Prices
- 232 Taxation and Public Finances in South Dakota
- 234 South Dakota Potatoes, Production, Prices, Destination
- 255 Cattle Ranch Organization and Management in Western South Dakota
- 259 Prices Paid to Producers of South Dakota Farm Products
- 269 Freight Rates and the South Dakota Farmers
- 282 Farmers' Elevators in the Spring Wheat Area of South Dakota
- 286 Reliability and Adequacy of South Dakota Farm Price Data
- 292 An Analysis of General Property Tax Trends in South Dakota with Suggestions for Administrative Reform
- 300 Inequalities Arising from the Assessment of Farm Real Estate in South Dakota
- 317 South Dakota Farm Prices 1890-1937
- 322 Tax Delinquency and County Ownership of Land in South Dakota
- 326 County Land Management in Northwestern South Dakota
- 328 Cooperatives in South Dakota

## Experiment Station Circulars

- 2 Indebtedness on 48 Potter County Farms
- 4 Farm Real Estate Mortgage Loans in Hyde County
- 5 Real Estate Mortgage Loans in Haakon County
- 6 Tractor & Horse Power in the Wheat Area of South Dakota
- 7 Farm Mortgage Experiences of Life Insurance Companies in South Dakota
- 8 Emergency Farm Adjustments in the Wheat Area of South Dakota
- 9 Some Aspects of Farm Mortgage Situation in South Dakota
- 10 Mortgage Loans on Farm Real Estate in Clark County
- 11 Motor Truck Transportation in Western South Dakota
- 12 Mortgage Loans on Farm Real Estate in Turner County
- 17 Farm Mortgage Foreclosures in South Dakota 1921-32
- 18 Assessment of Farm Real Estate for Taxation Purposes in Brown County, South Dakota
- 19 An Economic Study of Farms in the Spring Wheat Area of South Dakota
- 21 Estimated Returns from Operating Eight Hundred Acres in the Spring Wheat Area under Four Different Plans
- 23 Mortgage Loans on Farm Real Estate in Brookings County
- 24 Business Activity in South Dakota 1915-38

## AGRICULTURAL ENGINEERING

- 239 Costs and Uses for Electricity on South Dakota Farms
- 241 Cost of Electricity for the Home Electric Refrigerator
- 251 Combining Grain in Weed-Free Fields
- 252 Value of Grinding Grains and Roughages for Livestock
- 277 Rammed Earth Walls for Farm Buildings
- 297 Hitches for Field Machinery
- 298 The Relation of Colloids in Soil to its Favorable Use in Pise or Rammed Earth Walls
- 303 The Two-Row Cultivator Converted into a Weed Control Machine
- 333 Homemade Rubber Tired Carts and Trailers

**AGRONOMY**

- 183 Barley Culture in South Dakota
- 187 The Influence of Length of Wheat Heads on Resulting Crops
- 191 Water as a Limiting Factor in the Growth of Sweet Clover
- 200 Winter Wheat in South Dakota
- 201 Some Experiments with Spring Wheat in South Dakota
- 205 Some Tentative Statements Concerning Fowlds Hulless Oats
- 210 Some Chemical Characteristics of Soft Corn
- 213 Growing Flax in South Dakota
- 220 Date of Seeding Winter Rye
- 221 Trials with Commercial Varieties of Canning Peas
- 222 Wheat in South Dakota
- 227 Spring Seeding Time for Wheat, Oats, Barley and Flax in South Dakota
- 228 A Study of Certain Physical and Chemical Characteristics of Flaxseed and Linseed Oil
- 230 Better Oats for South Dakota
- 245 The Possibility of Utilizing Selfed Strains in Practical Corn Improvements
- 256 Barley Production in South Dakota
- 268 Spring Wheat Varieties for South Dakota
- 270 Variations in Amounts of Carbohydrates in the Leaves of Corn
- 272 Crop Yields Over Nineteen Years from Highmore Experiment Farm
- 275 The Germination of Seed Corn and its Relation to the Occurrence of Molds During Germination
- 276 Winter Wheat Production in South Dakota
- 280 The Results of Twenty Years Complete Soil Fertility Tests at Brookings, S. Dak.
- 285 Sorghums for Forage and Grain in South Dakota
- 291 Small Grains and Flax Varieties in South Dakota
- 299 Hybrid Corn
- 305 Field Bindweed
- 312 Twenty-one Years of Crop Yields from Cottonwood Experiment Farm
- 314 A Preliminary Study of the Effect of Cultivation on Certain Chemical and Physical Properties of Some South Dakota Soils
- 325 Results of Thirty Years Soil Investigations in South Dakota
- Tech. Bul. No. 1 Sorghum, Its Content of Cyanide or Prussic Acid

**Experiment Station Circular**

- 1 Reprint of "Soil Survey"

**ANIMAL HUSBANDRY**

- 189 Corn and Millet Silage for Fattening Cattle
- 199 Sunflower Silage for Steers; Smutted Corn Silage for Pregnant Cows
- 207 Forage Crops for Lambs
- 209 Potatoes as a Feed for Fattening Pigs
- 216 Improving Winter Rations for Pigs
- 219 Soft Corn for Fattening Cattle
- 229 Stacked Green Corn for Cattle
- 252 Value of Grinding Grains and Roughages for Livestock
- 271 Rye as a Fattening Feed for Cattle and Swine in South Dakota
- 278 Methods of Feeding and Grain Rations for Fattening Lambs
- 283 Oil of Chenopodium and Chenopodium Plants for the Eradication of Round Worms in Swine
- 293 Ground Flax and Other Protein Supplements with Corn for Fattening Calves and Pigs
- 316 Proso as a Fattening Feed for Swine
- 329 Tankage, A Protein Supplement for Fattening Beef Calves

**Experiment Station Circular**

- 3 Preliminary Report—Feeding Flax Straw to Cattle

**CHEMISTRY**

- 168 Breakfast Foods and Their Relative Values
- 311 Alkali Disease or Selenium Poisoning
- Tech. Bulletin No. 2 Selenium in Rocks, Soils and Plants

**DAIRY HUSBANDRY**

- 188 Relative Values of Feed Proteins for Dairy Cows
- 203 Pasteurization of Market Milk in the Glass Enameled Tank and in-the-Bottle
- 206 Purebred Dairy Sires
- 215 Soybeans for Dairy Cows
- 218 Bacterial Flora of Normal Cow's Udder
- 231 Feeding the Dairy Herd for Profit
- 236 Self Feeders in Dairy Calf Feeding
- 252 Value of Grinding Grains and Roughages for Livestock
- 257 Clarification vs. Filtration of Milk
- 264 Emmer (Speltz) for Dairy Cows
- 265 A Comparison of Alfalfa, Sweet Clover, and Sudan Grass as Pasture Crops for Dairy Cows
- 266 Essentials in the Success of a Local Cooperative Creamery
- 273 The Effect of Milk Foam on Dairy Calves
- 281 Oat Feed as a Substitute for Roughage
- 290 The Detection of Mastitis in Dairy Herds
- 296 Vitamin D in Milk
- 304 Relation of the Amino Content to Milk
- 308 A Holding Test at Room Temperature as an Indication of the Keeping Quality of Butter
- 319 The Effect of Sunlight on the Growth, Production and Reproduction of Dairy Cattle
- 321 The Effect of Season and Feeds on the Vitamin D Content of Milk Under South Dakota Conditions
- 324 Ten Years of Experimental Results on Cultivated Pastures
- 331 Factors Affecting the Composition of Milk

**Experiment Station Circulars**

- 22 Production of Quality Milk and Cream on the Farm
- 27 Bloat in Dairy Cattle

**ENTOMOLOGY-ZOOLOGY**

- 190 The Webb Spinning Sawfly of Plums and Sandcherries
- 202 The Chinch Bug
- 217 The Wheat Stem Maggot
- 288 The Plum Tree Borer; Its Distribution, Life History, Economic Importance and Control
- 295 The Common Black Field Cricket a Serious Pest in South Dakota

**HOME ECONOMICS**

- 247 The Use of Time by South Dakota Farm Homemakers
- 261 Vitamin C Content of Fresh and Canned Spinach, Swiss Chard, Asparagus and Carrots
- 306 Vitamin B in Lamb Tissues and Organs

**HORTICULTURE**

- 224 Plant Introductions
- 237 Experiments in Plant Heredity
- 240 Hardy Roses for South Dakota
- 246 The Shade, Windbreak, and Timber Trees of South Dakota
- 254 Evergreens in South Dakota
- 260 Ornamental Trees of South Dakota
- 263 The Shrubs and Climbing Vines of South Dakota
- 309 Fruits, Old and New and Northern Plant Novelties

**PHARMACY**

- 283 Oil of Chenopodium and Chenopodium Plants for the Eradication of Round Worms in Swine

**POULTRY**

- 242 Results of Poultry Feeding Experiments
- 243 Marketing and Poultry Products
- 330 Cereal Grains in Turkey Rations

**RURAL SOCIOLOGY**

- 233 Equalizing Library Opportunities in South Dakota
- 250 The High School Education of Farm Boys and Girls in South Dakota
- 258 Rural Health Situation in South Dakota
- 274 South Dakota Town-Country Trade Relations
- 279 The Growth and Decline of South Dakota Trade Centers
- 289 Rural Relief in South Dakota with Special Attention to Rural Relief Program
- 294 The Social Problem of the Church in South Dakota
- 301 Public Library Service in South Dakota
- 302 Immigrants and Their Children in South Dakota
- 310 Current Relief Trends in South Dakota
- 313 Immigrant Settlement and Social Organization in South Dakota
- 315 Rural Population Mobility in South Dakota
- 318 The Extent of Dependency upon Old Age Assistance in South Dakota
- 320 The Standard of Living of Farm and Village Families in Six South Dakota Counties, 1935
- 323 Social and Economic Circumstances of Accepted Applicants for Old-Age Assistance in South Dakota, 1936-1937
- 327 Basic Trends of Social Change in South Dakota—Population Tendencies
- 332 Dependent Children in South Dakota

**VETERINARY**

- 283 Oil of Chenopodium and Chenopodium Plants for the Eradication of Round Worms in Swine
- 307 Hemorrhagic Septicemia