

8-2018

ACHIEVING UNIVERSAL LIAISONS AND HEALTHCARE CONTACT CENTER CENTRALIZATION THROUGH THE USE OF DECISION SUPPORT TOOLS

Jared S. Fiacco

Binghamton University--SUNY, jfiacco2@binghamton.edu

Follow this and additional works at: https://orb.binghamton.edu/dissertation_and_theses

 Part of the [Operations Research, Systems Engineering and Industrial Engineering Commons](#)

Recommended Citation

Fiacco, Jared S., "ACHIEVING UNIVERSAL LIAISONS AND HEALTHCARE CONTACT CENTER CENTRALIZATION THROUGH THE USE OF DECISION SUPPORT TOOLS" (2018). *Graduate Dissertations and Theses*. 83.
https://orb.binghamton.edu/dissertation_and_theses/83

This Thesis is brought to you for free and open access by the Dissertations, Theses and Capstones at The Open Repository @ Binghamton (The ORB). It has been accepted for inclusion in Graduate Dissertations and Theses by an authorized administrator of The Open Repository @ Binghamton (The ORB). For more information, please contact ORB@binghamton.edu.

ACHIEVING UNIVERSAL LIAISONS AND HEALTHCARE CONTACT
CENTER CENTRALIZATION THROUGH THE USE OF DECISION
SUPPORT TOOLS

BY

JARED FIACCO

BS, Binghamton University, 2017

THESIS

Submitted in partial fulfillment of the requirements for
the degree of Master of Science in Industrial and
Systems Engineering in the Graduate School of
Binghamton University
State University of New York
2018

© Copyright by Jared Fiacco 2018

All Rights Reserved

Accepted in partial fulfillment of the requirements for
the degree of Master of Science in Industrial and Systems Engineering
in the Graduate School of
Binghamton University
State University of New York
2018

August 3rd, 2018

Dr. Mohammad T Khasawneh, Advisor & Committee Member
Department of Systems Science and Industrial Engineering, Binghamton
University

Dr. Nagendra N Nagrur, Committee Member
Department of Systems Science and Industrial Engineering, Binghamton
University

Dr. Sreenath Chalil Madathil, Committee Member
Department of Systems Science and Industrial Engineering, Binghamton
University

Abstract

Healthcare contact centers often experience a large volume of calls and traditional standardized guidelines can be difficult to follow during an active call. While more common workflows can be memorized, they change often because Healthcare is a dynamic field. Constant updates to workflows, an abundance of different processes and provider preferences, and a fast-paced environment can lead Customer Service Representative (CSRs) to handle patient inquiries incorrectly. Active decision support tools enable a CSR to follow an updated workflow without needing to navigate through complex guidelines and emails. This research shows that contact center centralization through the use of decision support tools can reduce Average Speed to Answer by 70 seconds even with an increase to Average Handle Time by 30 seconds. This research also identifies key features the tool may need to facilitate widespread adoption by clinicians and CSR alike.

Acknowledgements

They say it takes a village to raise a child; the same could be said for this thesis. There are so many people to whom I owe gratitude. Firstly, Alex Wnorowski, who came up with the idea for further centralizing a healthcare contact center through the use of decision support, developed JARVIS, taught me VBA, helped me communicate my ideas, and still is the inspiration for much of the great work the Contact Center is involved in. Thanks for all your help, you did what you could. I appreciate it. Next, Dr. Sreenath Chalil Madathil, who would answer my last-minute emails, field my unplanned calls, and always kept me on track against all odds. Without you, my thesis would still be in the literature review phase. To Dr. Mohammed Khasawneh, Dr. Sang Won Yoon, Dr. Jinkun Lee and all other Binghamton Professors who worked with me extensively as an undergrad, saw potential, recommended the graduate program, and helped me get the funding needed to work at the contact center. Your dedication to the students and your ability to find and mold talent is what makes a Binghamton ISE degree so valuable. To Binghamton's amazing staff, including Erin Hornbeck, Lindsay Buchta, Tracy Signs, and Michele Giorgio. You all made me feel at home in the department and made it easy to navigate academic life without missing a beat. To the Hinman Residential community, as Andy from The Office once said, "I wish there was a way to know you're in the good old days before you've actually left them." To my friends and family, thank you for supporting me and giving me a much-needed thesis pep talk every week. To everyone at the contact center that had a hand in JARVIS or other projects I've worked on. Denise, Beverly, Vedad, Lisa, Juan, Cameron, Bellinger, Dom, Steve, Kat, Matt, Edgar, Judy, Robert, Allison, Richard, Dan, Jen, Willy, Sam, Laury, Donna, Mark, Kareem, Scherria, John, Verna, Sharon, Hasel, Jackie, Marium, Marryl, Randy, Therresa, Issabelle, Quest, Jasmine, Rafaellea, Reggie,

Yvette, Akeel, Kelvin, Vanellys, Nakkia, Scherria, Anthony, Niree, and everyone else I've worked with. Good luck with the PAC, I wish you all the best. Finally, to the readers. As Michael Scott once said, "Sometimes I'll start a sentence, and I don't even know where it's going. I just hope I find it along the way."

Table of Contents

Acknowledgements.....	v
List of Tables	ix
List of Figures.....	x
Chapter 1 : Introduction	1
1.1 Background Study.....	1
1.2 Motivation	2
1.3 Research Problem.....	3
1.4 Research Goals and Objectives	3
1.5 Research Contributions	4
1.6 Thesis Overview.....	5
Chapter 2 : Literature Review	6
2.1 Contact Centers	6
2.2 Contact Center: Performance Measurement	7
2.3 Contact Centers: Role in Healthcare	12
2.4 Contact Centers: Decision Support	14
2.5 Decision Support in Healthcare: Facilitators and Barriers.....	17
2.6 Contact Center Decision Support: Positives and Negatives.....	21
2.7 Centralization: A Strategy for Contact Center Improvement.....	22
2.8 Research Contribution.....	28
Chapter 3 : Decision Support Tool Development within a Healthcare Contact Center.....	29
3.1 Relevant Contact Center and Healthcare Technologies	29
3.2 Contact Center Homegrown Decision Support Tool	36

3.3	Graphical User Interface	57
3.4	Developer Graphical User Interface.....	70
Chapter 4 : Case Study		82
4.1	Phase One: Define	83
4.2	Phase Two: Map.....	90
4.3	Phase Three: Workflow Standardization.....	95
4.4	Phase Four: Automation in Decision Support Design	105
4.5	Phase Five: Evaluate	117
4.6	After Hours Call Kick Out	125
4.7	Summary	147
Chapter 5 : Conclusion		150
5.1	Research Summary.....	150
5.2	Significance of Research	152
5.3	Future Work	152
5.4	Summary	153
References		154

List of Tables

Table 1: Facilitators and Barriers to Decision Support in Healthcare	18
Table 2: Advantages and Disadvantages to Utilizing Decision Support in a Contact Center	22
Table 3: Literature Review References Part 1	26
Table 4: Literature Review References Part 2	27
Table 5: Healthcare Contact Center Technologies	29
Table 6: Major, Sub, and Root Scenario Identification Table	87
Table 7: Contact Center Terminology	119
Table 8: Simulated and Actual Incoming Call Volume and Percentage Error	130
Table 9: Simulated and Actual Event Duration	135
Table 10: Simulated and Actual Average Wait Time and Percentage Error	137

List of Figures

Figure 1: Internal and External Consolidation.....	25
Figure 2: Yonyx Decision Tree Developer Interface (Left), Zingtree Decision Tree Developer Interface (Right)	33
Figure 3: Zingtree Decision Tree User Interface	34
Figure 4: Contact Center Process Map	37
Figure 5: Feedback Button.....	40
Figure 6: Feedback Table.....	41
Figure 7: Contact Table Part 1	44
Figure 8: Contact Table Part 2	45
Figure 9: Process Detail Table	47
Figure 10: Crisis Workflow Launcher Button	48
Figure 11: Spanish Call Signaling	49
Figure 12: Autologic Example.....	52
Figure 13: Scripting with Parsed and Stored Finesse Variables	53
Figure 14: Submodel Within Decision Tree	55
Figure 15: Start Button.....	57
Figure 16: Next Button	58
Figure 17: Previous Button	59
Figure 18: Responses Box	60
Figure 19: Result Text Box.....	61
Figure 20: Call Flow Complete Alert	62
Figure 21: Verbalize to Patient	63

Figure 22: Do Not Verbalize to Patient	64
Figure 23: Crisis Workflow Launcher	65
Figure 24: Feedback Button.....	66
Figure 25: Spanish Call Alert	67
Figure 26: Support Picture	68
Figure 27: Support Document.....	69
Figure 28: Exit System.....	70
Figure 29: Toolbar	71
Figure 30: Editing Dialog Boxes	71
Figure 31: Toolbar Editing.....	72
Figure 32: Relationship between the Developer Logic Design, the Logic Table and the User Interface.....	73
Figure 33: Adding Modules to the Workflow.....	74
Figure 34: Process Step- Editing Dialog Boxes: Inform Caller and Do Not Verbalize ...	75
Figure 35: Process Step- Action/Question Input	76
Figure 36: Process Step- Additional Information Box	76
Figure 37: Start Module	77
Figure 38: Decision Module	78
Figure 39: Solid Connectors	79
Figure 40: Process Module	80
Figure 41: End Module	80
Figure 42: Change Workflow Module.....	81
Figure 43: Baseline Call Opening: Manual IVR Contextualization	92
Figure 44: Patient Went to Pharmacy, Medication Not There.....	93

Figure 45: Appointment Preparation Workflow	95
Figure 46: Information Flow from Patients through CSRs to Clinicians	96
Figure 47: Line of Business Table	100
Figure 48: Provider Table	101
Figure 49: Queue Table	102
Figure 50: Line of Business and Provider GUI Auto-population	103
Figure 51: Routing Map Table.....	104
Figure 52: Scenario Table	105
Figure 53: Subgroup Table	105
Figure 54: Opening Workflow: Autologic IVR Contextualization	109
Figure 55: Developer End CRM Scripting Initiator	110
Figure 56: User End CRM Scripting Initialized	111
Figure 57: Medicine Names Left Blank.....	111
Figure 58: Line of Business Indicator Left Blank	112
Figure 59: Line of Business Indicator Drop Down (Pulled From CRM Database).....	113
Figure 60: Provider Indicator Left Blank.....	113
Figure 61: Provider Indicator Drop Down (Pulled From CRM Database).....	114
Figure 62: CRM Scripting and Pool Identification.....	115
Figure 63: Leave Feedback Request	117
Figure 64: Baseline Conceptual Model.....	121
Figure 65: Future State Conceptual Model.....	122
Figure 66: Contact Center Arena Simulation Model	123
Figure 67: Primary Care.....	124

Figure 68: Specialty Care.....	125
Figure 69: Call Kick Out.....	126
Figure 70: Close of Business Call Kick Out.....	127
Figure 71: Call Arrivals in Arena Model.....	130
Figure 72: Simulated and Actual Incoming Call Volume	131
Figure 73: Incoming Call Volume Percentage Error	132
Figure 74: Staffing in Arena Model.....	133
Figure 75: Simulated and Actual Event Duration.....	135
Figure 76: Event Duration Percentage Error	136
Figure 77: Simulated and Actual Average Wait Time.....	138
Figure 78: Universal Queue.....	139
Figure 79: Simulated Wait Time by Line of Business and Scenario.....	140
Figure 80: Paired T-Test and Confidence Interval for Current State vs. Future State Patient Wait Time	141
Figure 81: Average Scheduled Utilization by Department.....	142
Figure 82: Number of Calls answered by Line of Business and Scenario.....	143
Figure 83: Number of calls Handled and Scheduled Utilization	144
Figure 84: Single Queue Relationship Between Additional Increase to Event Duration and Resulting Patient Wait Time	145
Figure 85: Extended View of the Single Queue Relationship Between Additional Increase to Event Duration and Resulting Patient Wait Time	146
Figure 86: Effects of Increased Acceptance of Abandoned Call Volume on Average Patient Wait Time	147

Chapter 1: Introduction

The introduction chapter outlines the research questions this thesis is aimed at answering. The background on the field of study will be introduced along with the motivation. Research goals and objectives will be discussed, and research contributions will be outlined. Finally, the thesis document will be overviewed.

1.1 Background Study

Contact centers are seen by many individuals as the only way to access and navigate increasingly complex healthcare systems. However, contact centers have historically been cost centers for organizations. As healthcare becomes more competitive, it becomes more important to focus on reducing the cost of operating facets of the healthcare business. Contact centers can generate revenue for a healthcare system by scheduling patient appointments. Healthcare contact centers can staff more effectively by centralizing lines of business. In some cases, this may be a simple task to perform. In other cases, lines of business may be traditionally viewed as too different to facilitate centralization. In these cases, decision support tools may be developed and put into practice to facilitate these centralization efforts even if these lines of business are considered too different in a traditional sense. Decision support tools may be the key to gaining economies of scale out of healthcare contact centers previously believed to be operating as efficiently as possible.

1.2 Motivation

According to Fuchs (2013), in 2013, Healthcare expenses in the United States added up to about 18% of the nation's gross domestic product (GDP). Healthcare expenses are expected to continue growing over the next few decades. Fuchs estimates that healthcare costs will amount to 30% of the United States' GDP by 2040. In many instances, hospitals and healthcare systems are realizing increased pressures to do more with fewer resources and growing constraints. Healthcare systems often merge with other healthcare systems or acquire smaller healthcare systems to diversify and achieve economies of scale. Some healthcare institutions even diversify by geographic region. Leemore (2015) found that roughly one third of healthcare system mergers between 1998 and 2012 in the United States were amongst healthcare groups originating in separate geographical marketplaces. As technology changes, and self-help services become a more reliable way for patients to access their medical history (E. S. Corporation, 2016), many patients may not have the knowledge or means required to access the internet (Abdullateef, Mokhtar, & Yusoff, 2011). For these patients, a contact center remains as the main way they access and navigate healthcare enterprises. However, these patients still demand seamless navigation (Maxfield et al., 1998). As healthcare continues to expand, healthcare contact centers become more complex. Bailor (2005) notes that contact centers have been under pressure to go from a cost center in most institutions to become revenue generating through cross selling or selling customers additional products and services. Healthcare contact centers are not immune to these increased demands. Over the last two decades, decision support systems have proven to improve quality of medical care, increase efficiency of resources, and lower the costs of delivering healthcare (Chaudhry et al., 2006). Additionally, evidence shows that contact center centralization can help facilitate cost reductions (Sedgley, 2014). This

thesis aims at understanding the effects of developing and implementing a decision support system to facilitate centralization within a healthcare contact center.

1.3 Research Problem

This thesis discovers and outlines the benefits of contact center centralization from the patient perspective and the organizational perspective. A contact center operating with segmented lines of business may be unable to collapse these lines of business without a way for Customer Service Liaisons (CSRs) to organize and navigate the necessary information to handle each call. Decision support systems can help CSRs navigate through a call-in complex workflow. In healthcare, contact center workflows often change and are updated as best practices are modified. Keeping track of dynamic changes in a healthcare contact center is a demanding task for CSRs. Often, mistakes are made and old workflows are taken. A decision support system that utilizes the most updated workflow each time the system is initiated is a solution to this problem. Additionally, the decomplexifying of workflows using a decision support system can lead to all CSRs within a contact center being skilled to handle all inquiry types that are listed in the decision support tool. A CSR skilled to handle all inquiry types is referred to as a universal liaison. If a universal liaison can be achieved, a contact center's lines of business can be centralized by routing all inquiries to the universal liaison. To study the benefits of contact center centralization using this universal liaison, a simulation model was developed.

1.4 Research Goals and Objectives

The goal of this thesis is to create a decision support tool that can facilitate the centralization of a healthcare contact center. The decision support tool features developed and explained in this thesis can serve and benefit industry professionals aspiring to develop

a decision support tool for other healthcare contact centers. This thesis also aims to outline the limitations of a future state centralized system, so industry contact centers can determine if the development and maintenance of a centralized contact center meets the return on investment criteria before spending time and money on development.

The objectives of this thesis are as follows:

- Review current literature about contact centers, healthcare, and decision support tools
- Develop a decision support tool that can facilitate contact center centralization
- Identify decision support features that will help promote widespread adoption in a healthcare contact center setting
- Create, verify, and validate a simulation model to determine the benefits of contact center centralization through decision support tools

This research proposes that the use of decision support tools in a healthcare contact center can facilitate centralization, boost the efficiency, level load the resource utilization, reduce the costs of staffing, and increase the capacity of the system.

1.5 Research Contributions

Much of the healthcare decision support research that exists is not focused on contact centers. The research that is focused on healthcare contact center decision support tools discusses the benefits of using the tools like customer satisfaction and improved accuracy rates but does not consider the effects of harnessing the decision support tool to achieve centralization within the contact center. Research also exists that discusses the

benefits of contact center centralization, but it is limited in the technological approaches at centralization like decision support tools or the discussion of integrating a decision support tool with existing healthcare Electronic Health Record technologies. Utilizing a preexisting centralization framework, this thesis measures the benefits of using decision support to achieve a centralized healthcare contact center.

1.6 Thesis Overview

This thesis aims at determining the benefits of using a decision support tool to achieve universal CSRs and centralizing segmented lines of business in a healthcare contact center. This thesis also aims at identifying and developing decision support features that are likely to facilitate widespread adoption of the tool. Chapter 2 investigates the existing research and analyzes the current research gaps. This literature review focuses on decision support tools in healthcare environments, healthcare contact center research, and contact center workforce centralization. Chapter 3 aims to outline current contact center technologies relevant to the decision support development. These technologies include voice of the customer surveys, telephony systems, Interactive Voice Recognition software, OneNote and PDF guidelines, and contact center decision support tools. Chapter 4 outlines the decision support tool developed in the studied contact center. This chapter outlines important features developed to facilitate future adoption. In Chapter 5, the research methodology and the case study are introduced. This chapter follows the research methodology to analyze the benefits of a centralized contact center and analyze the future state sensitivity. The final chapter, Chapter 6 summarizes the research and outlines future work that can be performed.

Chapter 2: Literature Review

The literature review chapter outlines the current literature involving contact centers, and the utilization of decision support tools in a healthcare environment. Section 2.1 reviews the use of decision support tools in the healthcare environment over the past few decades. Facilitators and barriers to successful implementation of a decision support tool are discussed. In Section 2.2, advantages and disadvantages of utilizing a decision support tool in a contact center are introduced in regard to contact center centralization.

2.1 Contact Centers

Contact centers have been an industrial staple since the 1980s (Rijo, Varajao, & Goncalves, 2012). A contact center is an infrastructure that handles customer concerns via telephonic systems (Pow, 2017). In certain cases, contact centers handle customer inquiries via emails and live web chats as well. When customer inquiries cannot be handled by a CSR, they are escalated to a supervisor or an external party. In some cases, Interactive Voice Recognition (IVR) software aids in call routing and can automate certain contact center processes (Zak, 2014). Contact centers traditionally experience a high CSR turnover level (Pierre & Tremblay, 2011). This is likely due to a high level of disengagement in the industry (Welsch et al., 2016). This high turnover rate can greatly impact operating costs by increasing the cost of labor (Legleitner et al., 2015; Pigman, et al., 2017; Stamps, Claesson, McClendon, & Wieters, 2014). Contact centers have been a growing business, in 2012, Marcroux noted that the Canadian contact center industry grew 6,500% from 1998 to 2006.

2.2 Contact Center: Performance Measurement

Considering quality is a difficult task. In some cases, randomized spot checking may be the best practice. When it comes to accuracy of scheduling patients, the time taken to check each scheduled patient versus the standard takes a considerable amount of time. In a contact center environment, taking one CSR off of the phone to perform this accuracy check can greatly impact the patient wait time. Additionally, any errors the CSR encounters and fixes while performing their accuracy check are considered rework. Since rework is so expensive in terms of cost and impact to wait time, accuracy checks are often unperformed. When there is no baseline data on accuracy of scheduling patients, no conclusion can be made in reference to improving accuracy after decision support is implemented. The author of this endeavor suggests, although time costly, healthcare contact centers attempting to apply decision support to scheduling to any other essential function of their business determine a baseline accuracy rating. In the case of the observed contact center, average handle time temporarily increased after implementing decision support when scheduling patients. As time went on, the AHT reduced nearly to the levels seen prior to implementation. Stakeholders will want to see some immediate benefit to the system. Accuracy rating may increase which could act as a way to achieve buy in from stakeholders until AHT reduces after CSRs get over the learning curve of the new product. If quality is built into the process of scheduling a patient, the accuracy rate should theoretically increase.

Chaudhry et al. (2006) performed a systematic review on the effects of quality, efficiency, and cost of health information technology on healthcare delivery. They found that most initiatives showed quality increases clustered between 12 and 20 percentage

increases. Most studies reviewed adherence to guidelines within a healthcare space. One goal of using a decision support tool within a healthcare contact center is to boost adherence to guidelines and standardize the use of guidelines through a concept akin to poka-yoke, or mistake proofing. The study also discovered that, in regard to efficiencies, the clinical teams' subject to the health information technology improved performance in the short term but could not comment on long term studies as they were not available.

Hui (2017) analyzed contact centers, the structure of calls, and politeness markers that allow calls to flow more easily when sensitive subjects arise. He stated that while there is much research regarding the language CSRs use on calls; however, few research articles regarding the structure of calls exist. This finding promotes the research of decision support within contact centers. Hui states some research was completed by Forey and Lockwood (2007) on call structuring where six stages of a call were found including opening, purpose, gathering information, purpose, service, and closing. A three-stage structure was proposed by Xu et al. (2010) where Opening came first, followed by service and finally closing. The researchers also added that these three stages could expand to five stages: opening, purpose, information, service, and closing. Hui (2004) also proposed a four-stage structure involving opening, requesting assistance, solution negotiation and finally closing the call. All three structures are fairly similar with the opening and closing in each and some information exchange and solution or services being delivered to the customer at the end.

Hui also studied politeness markers in a contact center environment. Hui notes that when a healthcare professional asks a patient for sensitive information, politeness markers can make a vast difference in the outcome. One popular strategy is to ask the patient for

permission to ask the question, and then ask permission again followed by the word please. Research suggests this strategy can help build trust between the caller and the CSR. Another strategy mentioned is called "pre-sequencing". With pre-sequencing, a CSR will ask a question about the upcoming question. This pre-sequenced question allows the patient to know where the conversation is going. One other strategy Hui mentions is to show context to why the CSR would ask the question prior to asking the question. An example of this would be: "I see you were trying to validate using our automated system, but the transaction failed out. Do you mind giving me your social security number, so I can verify your identity?" In the event where scripting the decision support tool is mandatory, using these strategies will help with the flow of sensitive information.

The information found in Hui's research is important while making a decision support tool. This information will prove valuable when CSRs probe about sensitive topics. At points in the workflow where CSRs ask difficult questions or need to deliver sensitive information, politeness markers can be scripted into the workflow to allow a smoother call and to reduce the likeliness of a patient taking offense. Additionally, Hui discussed call structure in his research. The workflows are modeled in a similar structure to the ones presented in his research. Hui discussed research that identifies an opening, a middle where a patient requests a service, and a CSR provides said service, followed by a closing.

Murdoch and Detsky (2013) discussed how big data will eventually be applied to the healthcare setting. In their research, they found that even though the use of electronic health records increases, and the total amount of data being collected on patients follows the same trend, much of this data is unstructured. For example, text regarding what

happened during a patient's interaction with a clinician is known as qualitative data and cannot be easily transferred into a relational database. One example of structured data would be a table that includes fields regarding the visit. Examples of these fields include the diagnosed disease, the action taken, the quantity of given to the patient or other relevant information. This is important to decision support research because it supports the need to create and maintain structured and actionable data that can be easily visualized. Demirkan and Delen (2013) make substantial remarks on how decision support tools can generate large amounts of data when used in a service environment. They back Murdoch and Detsky's claims that big data analytics can revolutionize an industry. If the information collected from a decision support tool is analyzed, targeted initiatives can facilitate rapid change that makes the service more effective and reliable. Murdoch and Detsky (2013) also discussed that when it comes to qualitative data such as electronic health records, healthcare lags in comparison to other industries in using big data to gain more knowledge. One example given is when natural language processing from EHRs predicted postoperative complications more accurately than the current methodology of using patient coding. This concept could also be applied to Clinical Relationship Messages or CRMs from the contact center. CRMs document what happened on each call. In most cases, CRMs are sent to clinicians or pharmacists. One example could be a patient attempting to refill their prescription. A patient might call the contact center immediately after their appointment with the physician wondering why their medication is not available at their pharmacy. In most cases, there is a 1-3-day turnaround time for prescriptions. At this point in the call, the CSR would check to see if the physician has sent the prescription to the pharmacy. If the physician did not send the prescription to the pharmacy, the CSR would

write a CRM to the physician requesting the prescription be sent to the pharmacy. If structured decision support data is used in conjunction with the unstructured CRM text, there may be a way of determining where a majority of CRM related errors happen, and improvement initiatives can potentially be directed at the major problems making the solutions more effective. The researchers also discussed knowledge dissemination. While the data pulled from decision support tools can be analyzed to find the most efficient and effective call routes, using decision support will help train CSRs on the job. As workflows change based on clinician preferences and as best practices change, each CSR will have the most relevant and up-to-date information when they are using the decision support tool. Other tools including guidelines can also have the most up-to-date information. However, to find the most relevant information to the specific point in the specific call requires searching time. Next, the researchers proposed using healthcare data and integrating it with other sources to make analytics more powerful. This could be useful to the contact center. For example, there may be clinical data involving scheduling. Analysis could be enhanced if this data is integrated with data regarding which flows the liaisons took to schedule patients. Finally, the researchers mentioned that data analysis could help patients play a larger role in their care. Decision support allows healthcare to take knowledge about a patient's health and help drive better outcomes. As best practices are changed and used with decisions support tools, healthcare systems may find an improvement in outcomes among the patients who were exposed to the decision support tool. This research article was relevant to the development of decision support tools. It is important to produce structured data whenever possible. There were also possible use cases of healthcare contact center decision support tools inferred from this article. When decision support tool data is

analyzed in conjunction with other health systems data, there is potential for a contact center to add more value to the organization when compared with contact centers that do not use decision support.

2.3 Contact Centers: Role in Healthcare

Coleman and Iyawa (2015) studied the improvement potential of leveraging mobile phones to facilitate healthcare delivery in rural areas. In this study, three rural communities were considered. The main outcomes from this study were that, if supplied the luxury of mobile phones, patients could choose to remain in home, away from the hospital. They do not experience the wait times as in-person patients would. Freely flowing information between healthcare professionals and patients allowed the patient to avoid costly travel and high healthcare wait times. Similarly, providing patients with a telemedicine or telecommunications option allows them to communicate with healthcare professionals and complete administrative tasks outside of the hospital opens up a new channel for these processes to become complete which can help reduce wait times for all patients.

Contact centers serve an incredible role in the healthcare field. In areas where socioeconomic conditions are harsh or a main portion of the population of patients is elderly, contact centers act as the only way to access the healthcare system for many patients. Even while technology expands to allow patients to take a self-service approach to handling their healthcare needs, there are some patients view contact centers as their main point of access. Often, healthcare contact centers face operational goals to reach more patients in less time. This quantitative is a common approach found across contact centers in many fields. At the same time, especially when it comes to scheduling, providers demand

accuracy as well as efficiency. In a contact center, it is important to balance the quality and time spent on each call. Only a certain amount of time can be reduced from each call before quality is also reduced. One way to achieve a greater level of access without increasing overhead or purposely decreasing AHT is through achieving higher economies of scale. The more sites a CSR can serve the more effective the contact center will be overall.

Contact centers are essential to the healthcare setting. Agrawal (2012) performed a study in a rural part of India where a hospital utilized a contact center to answer simple inquiries from patients, communicate with doctors and staff via email, schedule and maintain follow-up appointments. The study found a significant increase in patient satisfaction during follow-up visits, a reported decrease in waiting time while in the facility, a reported increase when considering the quality patients perceive while interacting with their doctors, and patients saw an economic benefit by being able to cancel or postpone their appointments in the case where they could not physically get to the clinic. When Agrawal performed this research, many barriers needed to be faced. Agrawal notes, convincing stakeholders about the potential of the research acted as a barrier. This thesis builds upon a framework to minimize the cost of operating a contact center including training its CSRs while maximizing the skill and effectiveness of each CSR. Agrawal also notes cultural barriers that prevented the research. Cultural barriers will likely appear while building decision support. Clinicians prefer standard workflows; however, mapping the standard can be a difficult process. Agrawal discusses trouble obtaining quality of data. This barrier will present itself in many projects, especially when one metric to evaluate effectiveness is based on quality.

2.4 Contact Centers: Decision Support

In 2008, researchers studied the effects of a decision support tool put into practice in a Canadian contact center staffed by healthcare professionals (Stacey, Chambers, Jacobsen, & Dunn, 2008). This study focuses on the implementation and the barriers behind implementing a decision support tool in a cancer specific contact center that is staffed by medical professionals. The contact center studied in this thesis focuses on scheduling patients and answering generic, non-clinical questions. It is also staffed by CSRs with, in general, no clinical background. Additionally, the medical professionals in the health system prefer CSRs not to attempt to answer any clinical questions the callers ask. The reason the medical professionals prefer CSRs not to attempt answering these types of questions is to reduce the liability of giving patients incorrect information. While there are differences between these studies, the barriers and lessons learned from the cancer-helpline study can still be applied to the current research. In the cancer-helpline study, the AHT increased from 11.93 minutes to 13.93 minutes. Additionally, in the Canadian contact center, the healthcare professionals were asked to focus primarily on the discussion of the clinical options of the patient. The contact center's goals were on quality rather than balancing quality with quantity of calls. This could be one reason why the AHT increased between the baseline and the implementation of the tool. The studied contact center in this thesis bases the CSR's performance as a balance between qualitative measures including reported inaccuracy of patient scheduling as well as quantitative measures including number of calls handled. In the Canadian contact center, using the decision support tool generally promoted a more informed discussion between the healthcare professional and the patient. The calls were scored on qualitative measures before and after the addition

training on the decision support tool. All of the measures were based on a binary score determining if the professional supplied the criteria during the call. After the calls were analyzed, the average use of the criteria among all the calls was calculated out of 100 percent. These criteria include tailoring the information to the caller's needs, using time efficiently, providing information, verifying stage of decision making, verifying time of decision, verifying decision, among others. After training, the usage percentage increased on every quality criterion. This study also found that the healthcare professionals preferred to use the decision support tool because it allowed them to deliver more information to the patient as well as discuss the pros and cons to the patient's list of options. In other studies, this acted as a barrier to widespread usage, but the researchers saw this as a facilitator in their Canadian contact-center setting.

Decision support involving scheduling physicians was one topic studied by Konrad's team in 2017. One main difference between this thesis and that study is that this thesis involves decision support around scheduling patients to a template where Konrad's team studied decision support when scheduling the physicians. In their study, Konrad's team used integer programming to virtually assess the operational impact on patient throughput from different physician schedules in a primary care environment. In their study, they designed a graphical user interface using Excel VBA. In this interface, the user inputs multiple clinical parameters that mimic real life. Then, VBA code utilizes integer programming to assess a list of possible schedules based on the inputted parameters. A variety of predefined scenarios are then assessed on the basis of monthly patient throughput. Some of the assessed scenarios include an extension of visit hours, additional full-time and part-time providers, additional examination rooms, and a variation on the number of slots specifically

for new and existing patient. Each scenario is run multiple times and throughput average was assessed alongside standard deviation. This study differs from the thesis because it considers optimization of provider scheduling instead of patient scheduling. In the future, a tool like the one mentioned in this study could be put into practice in conjunction with decision support for scheduling patients in hopes to reduce the cycle time on the template optimization from a provider perspective.

Sencer and Basarir Ozel (2013) utilized simulation models to develop a decision support system for contact center workforce management teams. The development process for this system required a data repository to store information, a graphical user interface (GUI) and a simulation model to analyze and run models based on given parameters. Spencer and Basarir Ozel developed their decision support tool to facilitate data driven workforce management decisions. The purpose of this paper is to develop a decision support tool that facilitates call workflows within a healthcare contact center environment. The interaction between the user and the GUI, the data repository and the simulation model from Sencer and Basarir Ozel's research is similar to the interactions between the user, the GUI, the data repository and the decision support tool in this paper. Sencer and Basarir Ozel designed their GUI in the VBA programming language after the Seref, Ahuja, and Winston literature describing the best practices around developing spreadsheet-based decision support systems using Excel and VBA for Excel. Throughout the work, these researchers identify practices like reference cells, user interfaces, professional appearance and branding, VBA forms, and the theory behind effective and ineffective GUI design. This resource is useful when developing decision support tools that rely on GUIs to distribute and collect process information.

The decision support discussed in this thesis is structured in a similar format where the opening acts as an introduction and addresses any issues the patient experienced in the interactive voice recording (IVR) menu, a middle where the CSR asks the customer what the customer needs, followed by the CSR servicing the customer and ending with a closing where the CSR asks if there is anything else the patient needs help with and thanks the patient for choosing the health system if the call is complete. Using strategies listed in Hui's research while building the decision support workflows may allow for structure and politeness to be built into each call making Hui's suggestions standard in the healthcare contact center.

2.5 Decision Support in Healthcare: Facilitators and Barriers

Decision support in the healthcare environment is no new topic. Decision support has been applied mainly to clinical decisions like diagnoses, prognoses, as well as allowing patients to quickly understand the pros and cons to certain treatment options. According to Ewlyn and company (2013), decision support has been researched in the healthcare field and has been helping clinicians make decisions throughout the past two and a half decades. They note that the use of these tools is promoted on a national level, especially since the implementation of the Affordable Care Act on 2010. They argue that even though decision support tools have shown tremendous results, widespread adoption has been slow to set in. In their study, the researchers focused on reviewing a large list of decision support related studies in a clinical setting and determine which ones were successful. They were trying to identify a list of attributes that can help influence the successful adoption of these tools into a clinical environment. The authors of this study reviewed over 500 abstracts and narrowed their scope to 51 articles to completely read through. Out of these studies, 17 of them were

considered useful to the topic and data was extracted from this group. After thoroughly reviewing these studies, the authors summarized the findings, and made suggestions on best practices to implement these tools. These Facilitators and Barriers are described in the table below.

Table 1: Facilitators and Barriers to Decision Support in Healthcare

Facilitators	Barriers
Training and skills development for providers prior to implementation	Providers disagree with decision support content
Identification of clinical champion	Decision support viewed as not robust enough
Identification of eligible patients is automated	Decision support increasing workload
Use of decision support prior to visit	Interpretation failure
Tool initiation is automated	Disinterest
	Paper-based

One of the suggestions they made for future decision support tools studies was following the Standards for Quality Improvement Reporting Excellence (SQUIRE) guidelines. According to IHI (Squire Guidelines, 2018), these guidelines make it easier for studies to be discovered by other researchers and provide lists that, if followed, make articles useful for continued research. Another suggestion the authors made was for new decision support researchers to not only talk about the barriers and facilitators to developing a successful decision support tool, but to also discuss the reluctance to use these tools on a professional and organizational basis (Squire Guidelines, 2018). While discussing this aspect of the tool, the researcher should also include the incentives that need to be put in place to allow the tools to bring a significant impact to the operations and outcomes of the industry.

Facilitators and barriers to implementing a decision support tool in a healthcare environment were also discussed by Ewlyn and company (2013). One of the most important facilitators was the ability to allow widespread access to the decision support initiated through the patient instead of access that only initiated by the practitioner. This idea is especially relevant to this thesis because the decision support is being accessed through non-clinical staff (CSRs). Additionally, the studied contact center for many people in this demographic is the only means of accessing the health system, which will, in turn, act as a means of distributing the decision support tool. Another facilitator of widespread use noted by Ewlyn's team was the identification of a champion for tool vetting and continued training on the tool. In this thesis, during the development of the scheduling decision support and the vetting of the non-scheduling decision support, a clinical champion, serving in a leadership role, was named and training was supplied to the CSRs before use.

Barriers to implementation were also discussed by Ewlyn and company (2013). One barrier often reported is a lack of trust in the tool from a clinical perspective. In this thesis, the scheduling decision support tool experienced a lack of trust from clinicians. Historically, clinicians at the studied health system closed off their scheduling template from the contact center because there was a lack of trust in the abilities of the CSRs to accurately schedule. The CSRs face a dynamic environment with practitioners moving from site to site, residents annually appearing and disappearing from the healthcare system, and scheduling preferences constantly changing. Before the implementation of the scheduling decision support, any changes in preference were sent through email and eventually added into the existing guidelines document. Even the most diligent CSR is

bound to make mistakes or schedule incorrectly. When a decision support tool is placed into the system, any incorrect scheduling can fall into two categories, malicious misuse of the tool and an incorrect or incorrect template within the decision support tool. CSRs who are found to misuse the tool often can either be trained or removed from the organization. Over time, trust in the decision support tool will be generated through the continued optimization of the scheduling templates with clinicians, and through usage mandated by the champion of the tool who serves as a clinical leader in the organization. Ewlyn's team summarized that call center-based decision support also experience requests from the organization to boost efficiency of calls that use the decision support tools even though certain decision support tools used can increase the AHT among calls that utilize the tool.

Kawamoto, Houlihan, Balas, & Lobach (2005) performed a systematic review to understand the facilitators of a decision support tool in a clinical environment. After analyzing 70 randomized and controlled trials, the researchers discovered four main attributes that generally drove to the success of a decision support tool. One attribute that often leads to success is features that automate clinical workload. When simple clinical workload, like calculating a patient's age based off of their birthdate, is automated clinicians are more likely to accept the tool. The more administrative task automation a tool offers, the more acceptance it receives assuming the workflow is standardized and accepted as well. The next facilitator was timestamp and location stamp actions. This automated data collection gives the medical professional peace of mind while collecting important information for managers and stakeholders. The next facilitator is that an actionable recommendation is provided. For the decision support tool to be perceived as valuable, it needs to provide a valuable output. The final attribute for successful decision

support tools was that they were computer based. While paper-based tools like process maps can provide a clinician with a general overview of the process or can provide reference to the process when needed, they are not practical to use each time the process is accomplished. These key insights help push the need for a computer-based decision support tool that automates processes, provides actionable outputs, and collects time stamped data. The decision support tool developed in this paper adheres to all attributes described above. When automation is possible, automated logic evaluators are placed within the decision tree workflow. Date and time stamps are collected along each click of the GUI. Valuable information is outputted from the system as the CSR executes the call; each process step provides the CSR with a task or question to answer. All information gathered is stored and can be referred to later in the flow.

2.6 Contact Center Decision Support: Positives and Negatives

One solution to reducing training costs could be the introduction of a decision support tool in the contact center. These tools can reduce cognitive workload and standardize the way CSRs handle inquiries. As the industry grew, many metrics were developed to track the productivity of the workplace. Some metrics include customer satisfaction a qualitative measure (Barthelus, 2015), Average Handle Time the number of seconds it takes to complete a patient's inquiry (Sedgley, 2014). Customer satisfaction can be improved through the use of scripting (Dzuba et al., 2015; Weiss, Brown, & Whaley, 2013). However, scripting through the use of decision support systems increased the average handle time in a 2008 study performed by Stacey, Chambers, Jacobsen, & Dunn. The table below explores the positives and negatives of implementing a decision support tool in a healthcare contact center.

Table 2: Advantages and Disadvantages to Utilizing Decision Support in a Contact Center

Positive	Negative
Ensure Standardization	Likely to Increase Handle Time
Automated Detailed Data Collection	Costs to Train CSR to Operate Decision Support Tool
Improve Customer Satisfaction	Costs to Develop Decision Support Tool
Facilitate Contact Center Centralization	Costs to Maintain Decision Support Tool
Decrease Training Time and Cost	
Predictable Handle Times	

2.7 Centralization: A Strategy for Contact Center Improvement

Research performed by Sedgley in 2013 shows standardization and centralization as one way to achieve a more efficient method of access and simulated five contact centers, performing similar tasks within the same health system, of various sizes as a baseline. The updated model consists of a single, centralized contact center and found that the centralized contact center performed better. However, one limitation was that the shared service was thought to only be achieved through combining similar tasks performed in different geographical regions. Through this research, Sedgley calls for centralization within contact centers and creates a discrete event simulation that compares key performance indicators from 14 similar segmented processes to one standard process. In the initial state, there were 10 primary care sites that handled similar processes through a central contact center and 4 sites that handled their processes on their own. This meant that there were FTEs assigned to handle each of the 4 segmented sites activities as well as FTEs assigned to the partially centralized contact center. Sedgley developed a framework that took these segmented processes and produced one standard workflow for each process type. For example, when it came to select an appointment for a new patient, the developed has one standardized

workflow that allowed a CSR to navigate through that call type and decomplexified the initial separate workflows to make one combined and standard new patient appointment scheduling workflow. This thesis repeated this process for each common call type and created a variation matrix. This variation matrix highlighted the key differences in each process. Its purpose was to act as a quick reference guide for CSRs while they took calls. The standardizing of the workflows helped to identify opportunities to improve them during the mapping process. The baseline simulation model developed as part of this thesis helped to prove that centralization of a contact center should be worked towards and initially considered the baseline partially centralized contact center. In the baseline simulation, each call generated went down a path designated for a specific primary care site. Each site is also split up between English calls and Spanish calls with separate distributions and handle times for each. After validating this model's accuracy to represent the current state environment, the expanded model considered 4 additional sites to the baseline, which showed an increased demand for more resources each time. The model used the abandonment rate metric as a basis to determine how many more CSRs should be added to the system as the contact center expands and welcomes more sites into its business.

Sedgley's simulation model determines the appropriate staffing levels needed to achieve targeted Key Performance Indicators (KPIs) as the number of primary care sites increases under the proposed centralized contact center model. The simulation from this thesis aims at understanding both the number of FTEs that can be reallocated to revenue generating tasks while continuing to meet KPIs. This thesis also focuses on determining how an increase in handle time among all calls will affect KPIs.

Sedgley's research also showed combining services that are vastly similar to each other can show efficiency gains. This thesis focuses on to realize economies of scale when combining dissimilar practices in a healthcare contact center by breaking through the previously limiting complexities through the use of decision support tools. The model focuses on centralizing the primary care sites that remained decentralized during the time of the study. In this case, there were 4 sites that had their own FTEs as well as 10 sites that had a centralized process within the contact center. Each primary care site in this case has workflows that are similar enough to each other where a CSR can easily navigate based on both scenario and site. In this thesis, the proposed simulation model, the scope goes beyond primary care to considering combining the primary care workflows as well as specialty care workflows. Currently, the primary care sites are centralized as one line of business, and each specialty is centralized by line of business. In this case, workflows are based on site, scenario, provider and line of business. Sedgley's work focused on external consolidation and combining primary care sites from external sources into one primary care line of business. This thesis focuses on consolidating primary care and specialty departments that are already located in the same geographical region. This type of consolidation is referred to as internal consolidation.

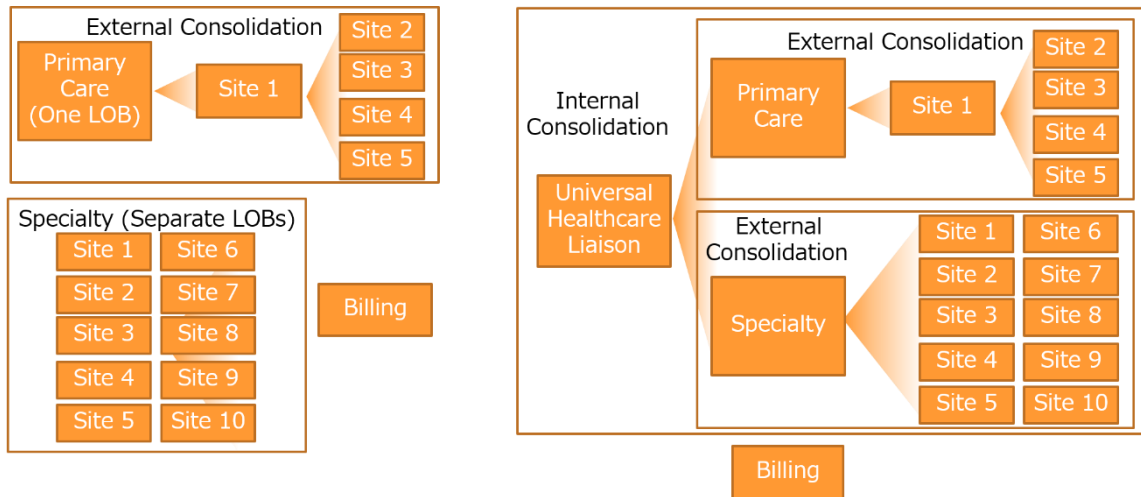

Figure 1: Internal and External Consolidation

Since there are many sites, scenarios, providers and lines of businesses involved in both primary care and all of the specialties, it is difficult for a CSR to easily understand the complexities and subtleties of each situation. In this case, a two-dimensional variation matrix, like the one in Sedgley's research, could not capture these complexities. Such a matrix would have to be multi-dimensional and consider thousands of variables which would make navigating and maintaining it rather difficult. Instead, a decision tree could accurately consider a large number of variables and route the CSR through the correct line of actions. While the proposed GUI is formed off of standardized workflows much like the ones in Sedgley's proposal, the GUI technology is a vehicle that a CSR can use to navigate through a call about any workflow, situation, and site with respect to any clinical group, not just ones with similar workflows.

Table 3: Literature Review References Part 1

Author	Topic										Description
	Healthcare	Contact Center	Decision Support	Simulation	Big Data	Workflows	Centralized Workforce				
Kawamoto, Houlihan, Balas, & Lobach (2005)	x		x								Systematic review of facilitators for decision support tools in a clinical environment
Chaudhry et al. (2006)	x		x								Systematic review of healthcare information technology on quality, efficiency, and cost of delivering healthcare
Forey, & Lockwood (2007)		x				x					Analysis and generalization of contact center workflows
Hanna, Ahuja, Winston (2007)			x	x							Guidelines to developing decision support systems using Excel and VBA for Excel
Stacey et al. (2008)	x	x	x								Implementation of decision support tool within a clinically staffed Canadian contact center
Pierre, & Tremblay (2011)		x								x	Assesses employee retention, engagement, and involvement in a contact center with the goal of improving the socioeconomic wellbeing of employees
Agrawal (2012)	x	x									Utilizing a healthcare contact center in rural India
Rijo, Varajao, & Goncalves (2012)		x			x						Discusses proper systems design for a contact center's data and information
Marcoux (2012)		x								x	Examines the work of CSLs in Canadian contact centers and the emotional effect managing customer inquiries each day
Demirkan, & Delen (2013)			x		x						Leveraging decision support data and features to facilitate service oriented analysis
Eliwyn et al. (2013)	x		x								Systematic review of facilitators and barriers of decision support implementation in healthcare environment
Murdoch, & Detsky (2013)	x				x						Discussion of big data application in the healthcare setting
Sedgley (2013)	x	x		x		x				x	Developed guidelines that allowed for centralization, simulated potential impacts
Sencer, & Basarir Ozel (2013)		x	x	x							Utilizing simulation to develop a decision support system for contact center work force managers

Table 4: Literature Review References Part 2

Author	Topic										Description
	Healthcare	Contact Center	Decision Support	Simulation	Big Data	Workflows	Contact Center Workforce				
Weiss, Brown, & Whaley (2013)		x				x	x				Understanding employee adherence to contact center scripting and its effect on customer satisfaction
Stamps, Claesson, McClendon, & Wieters (2014)		x					x				Evaluates retention rate for CSLs in inbound contact centers across the United States through the use of a case study
Zak (2014)		x			x						Calculates the value of introducing smartphone end user apps into a contact center environment from a customer perspective
Barthelus (2015)		x				x	x				Reviews the effects of cognitive loads on emotional labor in a contact center
Coleman, & Iyawa (2015)	x	x									Utilizing mobile phones to improve healthcare delivery in rural areas
Dzuba et al. (2015)		x				x	x				Explores the experiences of CSLs in regards to scripting the way customer inquiries are addressed
Legleitner et al. (2015)		x					x				Outlines, implements and evaluates a strategy to increase CL retention in contact centers
Welsch et al. (2016)		x									Measures the moods and engagement in a contact center in comparison to the retention rates
Hui (2017)		x				x					Contact center workflow analysis and generalization, politeness markers
Konrad et al. (2017)	x		x								Implementation of decision support tool to assess operational impact of physician schedules on patients
Pigman et al. (2017)		x					x				Appraises employee retention rates in an organizational contact center
Pow (2017)		x									Deliberates the characteristics associated with contact centers that successfully manage to receive a high customer satisfaction rating
Squire Guidelines (2018)	x		x								Guide on decision support tools within healthcare environment
Fiaoco (2018)	x	x	x	x	x	x	x				Development of decision support system aimed at creating a universal liaison, simulate and study the effects of centralized future state healthcare contact center

2.8 Research Contribution

Many papers have been written on call center performance, centralization of queues, obtaining a more universal liaison, and decision support in the healthcare field. However, few studies have shown the effects of utilizing decision support tools within a healthcare contact center environment. Of the studies that show these effects, there is no research based on improving accuracy of information or scheduling. There is also no research that focuses on expanding a non-clinical CSR's skills through the use of decision support. This thesis evaluates the potential operational effectiveness of a decision support tool in a healthcare contact center environment staffed by non-clinical CSRs. This thesis also provides a framework on how best to implement a non-scheduling-based decision support tool in the environment.

Chapter 3: Decision Support Tool Development within a Healthcare Contact Center

Chapter 3 describes the development of a decision support tool in a healthcare contact center environment. Section 3.1 recaps relevant contact center and healthcare technologies. Section 3.2 discusses the required features of a decision support system.

3.1 Relevant Contact Center and Healthcare Technologies

The table below describes the current technologies in a healthcare contact center that are of substantial relevance to this thesis.

Table 5: Healthcare Contact Center Technologies

Technology	Description	Example
Telephony System	A telephony system allows a contact center to map call routes, route calls, collect detailed call timestamp data, answer patient inquiries and transfer them as needed.	Cisco, Avaya, Polycom, Riverbed
Interactive Voice Recognition (IVR)	When a patient calls a contact center, they are generally read prompts by an automated system. In some cases, the patient is prompted to speak. When the customer speaks, the telephony system analyzes the speech and then routes the patient to the next prompt accordingly.	Cisco, Avaya, Polycom, Riverbed (IVRs are an important module within telephony systems)
Voice of the Customer Surveys	Voice of the Customer Surveys allow a contact center to develop accurate customer satisfaction metrics, and determine the amount of rework in the system by understanding if the patient's concerns were met on the first contact. These surveys allow for collection of qualitative data at a low cost to the contact center.	Aqueon, Survey Monkey, Google Forms, Microsoft Forms
Contact Center Decision Support Tools	Generally, each workflow can be standardized and process mapped. However, reviewing a process map while speaking to a patient substantially increases handle time. A graphical user interface (GUI) allows a CSL to navigate a process map on every call. Indirect decision support tools like PDF and OneNote guidelines offer an alternative to direct decision support GUIs. However, they act more as a reference to important material, instead of enforcing standardization of workflows.	Contact Center Focused: Zingtree, Yonyx Healthcare Focused: Epic Decision Tree Questionnaire Indirect Decision Support Tools: PDFs, OneNote

3.1.1 Telephony Systems

There are many telephony systems that a contact center can utilize to route and take calls. The studied contact center uses the Cisco telephony system. The Cisco telephony system collects data as the patient's call moves through the contact center. Data is collected from the patient perspective and can also be viewed from the CSR perspective. An example of data collected from the CSR perspective is the agent detail. Agent detail data displays every change in state and every interaction the CSR has with the telephony system. This information captures whether the call the CSR was on was inbound, outbound, internal, or a transfer. It also captures all the timestamps for each call. This data source captures if the CSR logged on or off of the Cisco system. It captures the length, start time and end time of every interaction. The system also captures the idle states, the length within each idle state and the frequency of idle usage for a given time period. This information is used to track important contact center metrics like number of calls handled, average handle time, and average time spent idling by idle type.

3.1.2 Interactive Voice Recognition

Interactive voice recognition (IVR) software allows a patient or customer of the contact center complete self-service actions without speaking to a CSR. IVR software prompts the customer with a question, and listens to the response, completes a task based on a standard workflow then prompts the next question or transfers to an agent or ends the call depending on the situation. The contact center studied used an iterative approach to implement IVR software, automate tasks and reduce the workload of the CSRs. There are many examples of when IVR software can be used to automate tasks in a healthcare contact

center environment. For example, each time a customer calls the studied healthcare contact center, they need to be authenticated. To do this manually, a CSR will ask the customer to say their name, social security number, address, and other identifying factors to prove the patient is who they say they are. This authentication process is completed to stay compliant with HIPAA laws that protect patient privacy. Since this process must take place on each call, even if it only adds a small amount of time, completing this task on each call adds up to a significant amount over time. The goal of using IVR automation software is to improve the patient experience by providing the patients an option to use the system when contact center wait times are high or after close of business for the contact center.

3.1.3 Voice of the Customer Surveys

Voice of the customer surveys can offer important insights on contact center quality metrics directly from the customer. ICMI states that a voice of the customer survey is the most accurate way to determine first call resolution. First call resolution is a qualitative metric that displays the value of each call. If a patient states that this call is the first call they've made for this particular issue, then the call is considered first call resolved. If the patient claims to have called multiple times about a persisting issue, the call is considered first call unresolved. The first call resolution metric is the percentage of calls that were first call resolved over the total sample size. There are multiple ways to administer voice of the customer surveys. In some cases, a contact center will email a survey to patients using their email list and survey monkey, Google forms, Microsoft forms, or other popular web service surveys. While this remains an option for certain patients, many patients within healthcare may have no access or limited access to email (Maxfield, Patrick, Deering, Ratzan, &

Gustafson, 1998). If this option is used, contact centers may be creating a clustered sample of patients who are knowledgeable of or have the means to access email.

3.1.4 Contact Center Decision Support Tools

Two popular software tools contact centers use to guide CSRs through the call are Zingtree and Yonyx. Zingtree and Yonyx both use hardcoded complex decision tree routing to define the flow of the call. They also have graphical user interfaces (GUIs) that allow the CSR to seamlessly take the caller through the same process step by step. Traditionally, a decision tree branches out exponentially as the processes complexify and more nodes are added onto the existing nodes. However, Zingtree and Yonyx decision trees allow branching with variables. Using these variables, the decision tree can branch, and diverge then converge again, storing the variables as the user flows through the tree.

The Yonyx decision tree allows for conventional decision tree splitting as well as the converging of decision tree logic. Using data collected from the use of the tool, the decision support tool allows the developer to view how often and what is the ratio of volume along each decision tree path. This information enables the developer to offer a more data driven solution and focus on reducing the workflow time for the most highly navigated workflows.

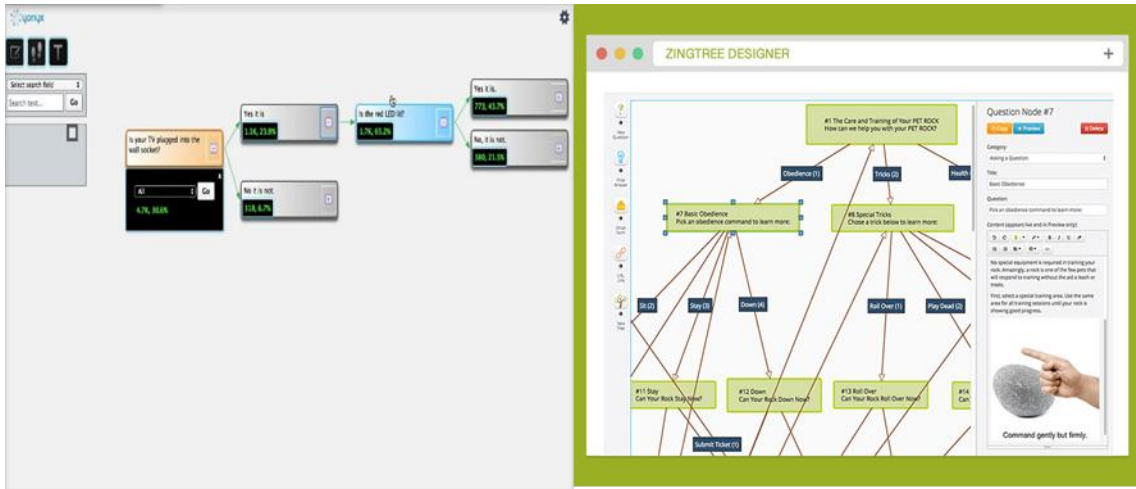

Figure 2: Yonyx Decision Tree Developer Interface (Left), Zingtree Decision Tree Developer Interface (Right)

The Zingtree user interface also allows the developer to include pictures that help the end user to gain more context while answering questions and navigating through a call. The developer interface allows for different types of notes and archs. One example of a node is a new tree. A new tree is a submodule that houses an entire separate decision tree. A new tree can be opened and developed to make a complex, segmented workflow appears neater on the developer interface.

The Graphical User Interface (GUI) for the end user looks different from the decision tree developer interface. While the developer interface allows for the developer to review the workflow in its entirety, the user interface narrows the scope of focus to one process step at a time. After answering each process step inquiry or following each process step and choosing to advance to the next step, the interface changes to represent the next node on the user's decision tree path.

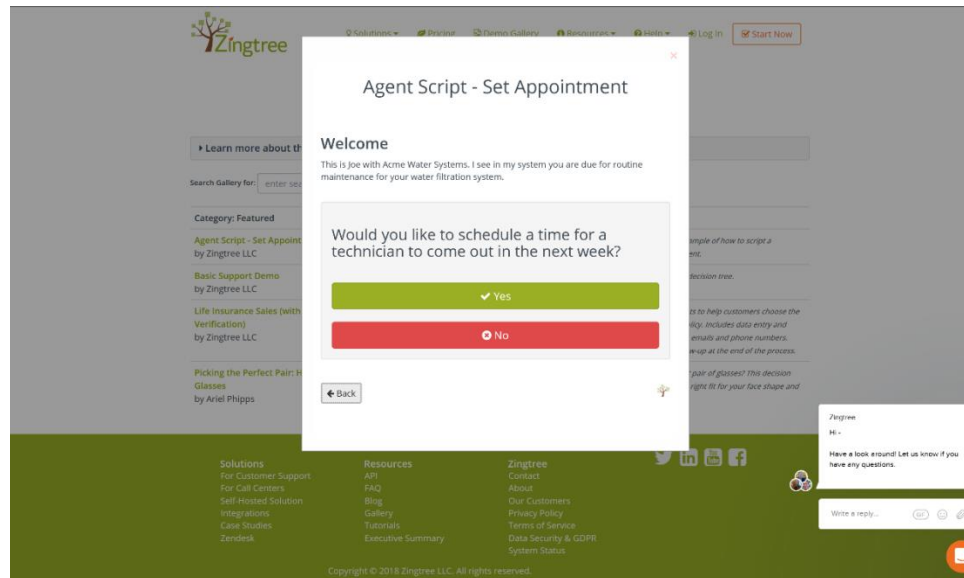

Figure 3: Zingtree Decision Tree User Interface

3.1.5 Other Useful Indirect Decision Support Tools: PDFs and OneNote

PDF guidelines outline common practices within the contact center. They can help guide a CSR through high volume calls and can help CSRs by providing a quick reference. Often, these guidelines are structured in a manner that enables quick navigation by chapter, or scenario. As best practice changes over time, guidelines often need maintenance. A user can easily navigate through guidelines using the Ctrl+F search functionality, however reviewing guidelines on every call can increase handle time substantially.

OneNote Guidelines are similar to PDF guidelines but offer a simple interface from the guidelines developer perspective. Tools like tabs and sections allow the developer to logically store important information based on category and topic. Additionally, hyperlinks can be added that link pages to one another. Audio and video recordings can be placed or embedded within the OneNote structure. Spreadsheets, tables and files can be added into the OneNote guidelines offer better visualization, and structure to data and to link to

internal sources of information which provide greater context. From a user perspective, the logical storage of information may be easier to navigate than a PDF. However, this OneNote solution does not solve the main issue of why the PDF guidelines were impractical. The Healthcare Contact Center environment is dynamic and constantly changing, and CSRs often cannot afford the luxury of reviewing the guidelines on every call. Using an active decision support tool may solve this issue because, if developed properly, it does not interrupt the natural flow of the call and can even help boost first call resolution while reducing some of the cognitive workload on the CSRs handling the calls.

3.1.6 Epic Decision Tree Questionnaire

Epic is a company that develops and sells Electronic Health Record software. There are many modules and functions Epic has in place that facilitates the delivery of healthcare. One module is Epic's questionnaire and decision tree-based questionnaire. This tool allows a contact center to build a decision tree that standardized patient scheduling. Epic's questionnaire facilitates the scheduling of a patient and has some potential to facilitate other contact center inquiries patients have. However, the Epic only allows one instance of the software to run at a time on Windows operating system. So, a CSR currently cannot use the questionnaire while navigating Epic's system to search for patient history. In some cases, questionnaire rules can automate the process of navigating, searching and answering questions about the patient's medical history. Limitations exist in building these rules. For example, if the patient is a new patient with a preexisting condition and a referral is not currently within the Epic system and the patient's history is not yet migrated, a rule that

looks through the patient's history to search for the patient's condition will not return with an accurate answer.

3.2 Contact Center Homegrown Decision Support Tool

When a patient calls with an inquiry, they first must answer a series of automated questions. These questions allow the patient's call to be routed to the appropriately skilled CSR queue. Once in the queue, the patient waits for a CSR to be available to handle their inquiry. When a CSR is available to handle their inquiry, they complete the patient's requests and before completing the call.

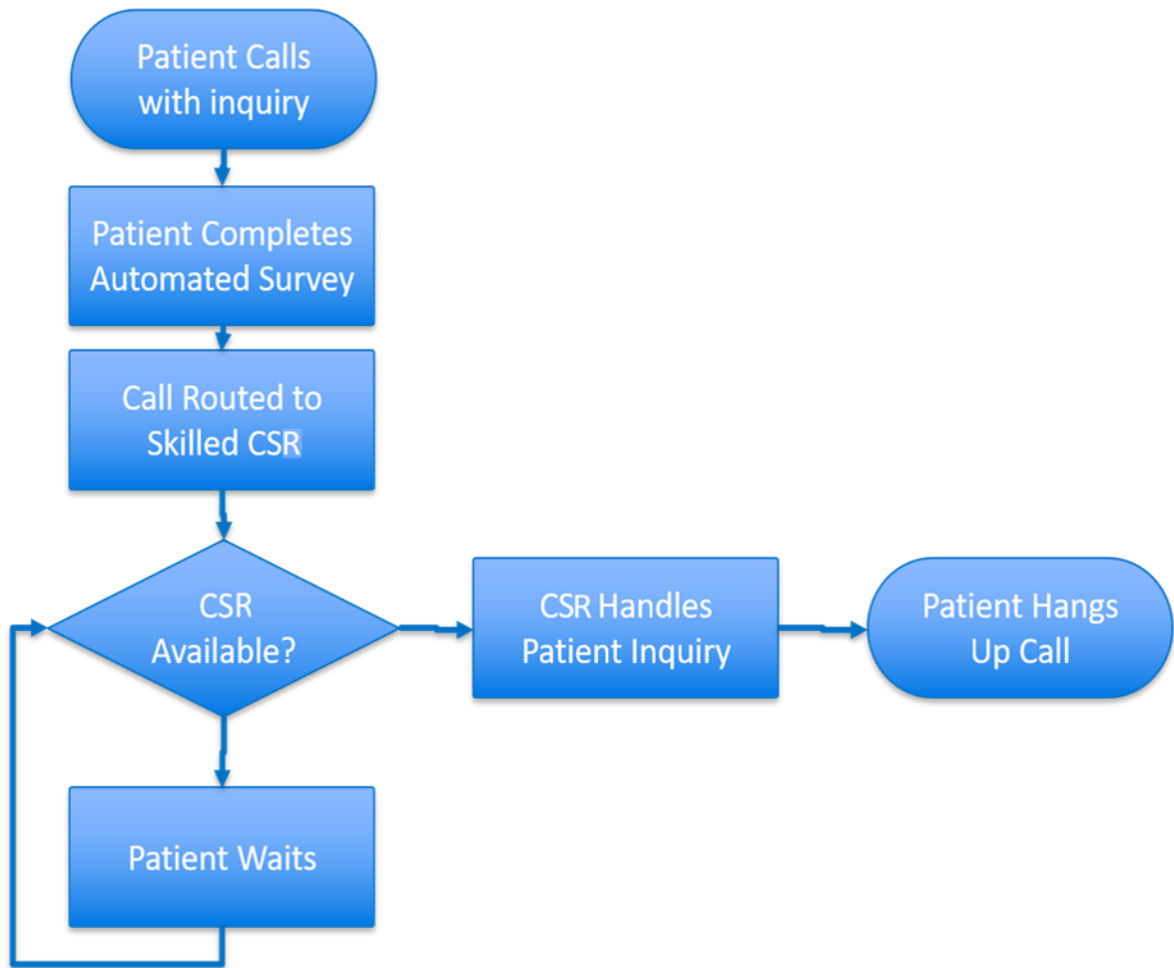

Figure 4: Contact Center Process Map

While there are nuances between Zingtree and Yonyx, there are a few basic principles that allow Zingtree and Yonyx become powerful tools when it comes to contact center decision support. The contact center studied in this thesis developed a similar decision support tool using Microsoft’s local suite of tools, namely VBA, Excel, and Access. This section explains development and implementation strategy to create and deploy homegrown, customized decision support software. Some key features of development were identified while performing the five-phase methodology. These additional features aimed at automating look-up procedures, improving the user

navigability, automating data collection, and enabling the developer to provide actionable information to the user.

One of the advantages of using a decision support system in a contact center is data collection based on how long it takes CSRs to complete processes and how frequently a patient inquires about each possible scenario. Need to determine if Call is active, only collect information when on active call. Prevent malicious action of clicking through calls to boost ranking.

To develop the workflows within the decision support tools that guide each call, Sedgley's five phase methodology for process mapping within a contact center was utilized. The five phases are define, map, standardize, design, and evaluate. In the define phase, the key stakeholders define requirements of the project, the project scope is outlined, and the expectations are clearly outlined. In the map phase, the developer speaks with subject matter experts to outline the current processes. Then, the subject matter experts verify and validate the process maps to ensure accuracy. In the standardize phase, the developer reviews the current processes and workflow maps of the current state and uses process improvement tools to standardize the nuances between processes. In the design phase, the developer creates a simulation tool that represents the current and future states within the contact center. The current state requires validation from subject matter experts and mathematical verification. The future state required validation as well. The future state is aimed at representing a centralized contact center. Finally, in the evaluate phase, the developer compares the current state and the future state and evaluates the return on

investment if the future state is pursued. The case study chapter provides an in-depth review of this methodology in action.

3.2.1 Feedback Button

When a patient inquires about a scenario that does not currently have a workflow within the decision support system, it is important for a CSR to give feedback to the developers of the decision support tool. When a CSR gives feedback, they should include the scenario the patient is inquiring about and the outcome or action taken for that scenario. The same should be said when a CSR experiences a workflow within the decision support tool that outlines incorrectly or guides the CSR in the wrong direction. A feedback button allows the CSR the opportunity to give the workflow developers feedback. The feedback data table consists of the contact id for the call, the process ID for the process step the CSR was on when submitting the request, a date stamp, a timestamp, and the feedback the CSR wants to leave. The contact id is important because it allows the individual in charge of reviewing the feedback to get context. In the studied contact center, each call is screen and audio recorded for the safety of the patients and the CSRs. So, the individual in charge of reviewing decision support feedback can listen to and watch the call.

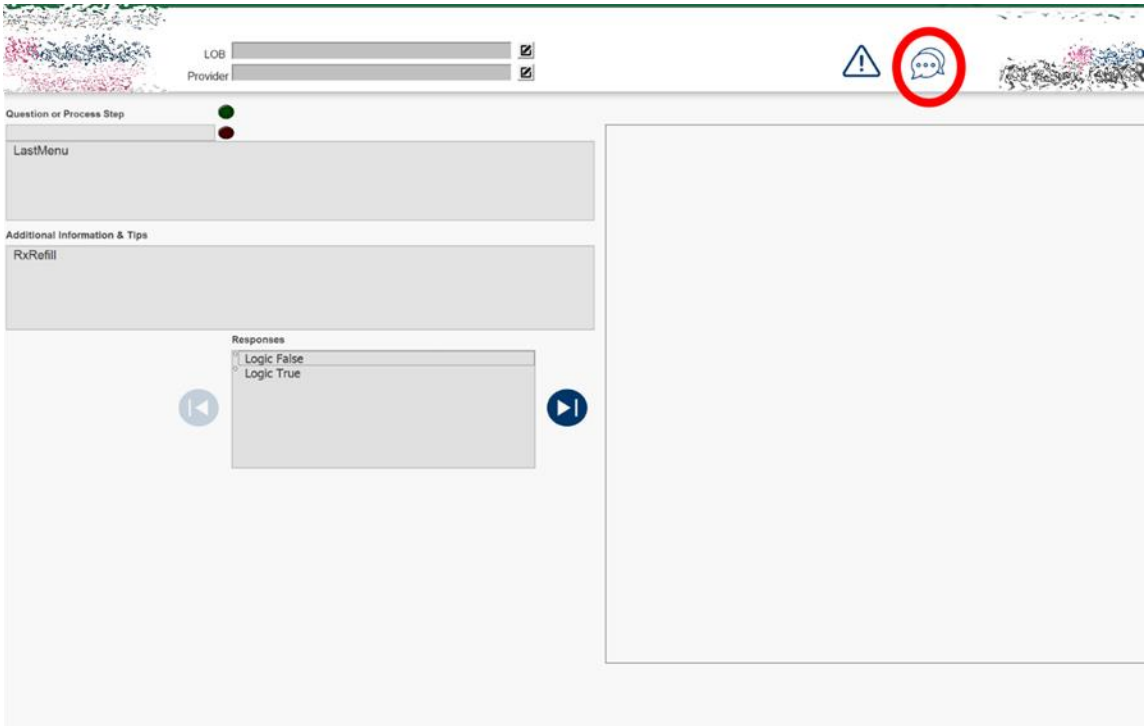

Figure 5: Feedback Button

Additionally, when a CSR clicks on the feedback button, it is necessary to collect data about the call if deeper context is needed. The contact id can be linked to the Contact table within the database. The process step allows the individual to obtain deeper situational context without needing to review the entire call. Additionally, the process step number can be linked to the process table within the database. The date and time stamp information can either allow the individual to fast forward to the exact point in the call when the feedback was written, and it will also help act as part of a feedback turnaround time metric. Finally, the feedback text is an important field to include in the table because it ideally contains the feedback, or suggestion on how the decision support tool could be updated to serve the CSR more effectively.

ID	CSN	PSN	SubmitDate	SubmitTime	Feedback
*	(New)				

Figure 6: Feedback Table

3.2.2 Contact Table

The contact table's primary key is the contact number. This is the primary identifier of the call. A new contact is originated each time the application is opened. The next field lets is a binary field that describes whether or not the CSR completed the workflow. If the CSR made it to an endpoint within one of the workflows, the workflow completed field will display "Y", otherwise, the field will display "N". The username stores the name of the CSR who answered the call. The final step identifier field displays the name of the last process step the CSR pressed before closing the application. This can be paired with the final workflow identifier to show the individual which was the last file the CSR's computer was pulling from before completing their call. The table also includes a start, end, and terminate time. The start time shows the timestamp for when the CSR initiated a new instance of the application, the end time displays when the CSR either closed the program or arrived at an endpoint, and the termination point displays the timestamp for when the CSR closed the application. The end time and termination time will be the same if the user did not complete the workflow by arriving at an endpoint. Otherwise, the two timestamps will be different. In this case, the end time would represent the time the CSR arrived at the end of the workflow, and the termination time would represent time the CSR closed out the application. The use date field represents the date that the call took place on. The studied contact center opens at 8am and closes at 6pm for most lines of business. If the contact

center was open for 24 hours and a call took place on 1-1-2018 at 11:59 PM and lasted for 2 minutes, the use date field would be labeled 1-1-2018. The Cisco Agent Identifier is a number that identifies which agent used the decision support tool during the call. This is needed in addition to the agent user name because multiple people can share the same name but only one person can have a distinct Cisco agent identifier. Additionally, the username is the name of the user who is logged into the computer accessing the decision support tool while the Cisco agent identifier is the number that identifies the user taking the call within the Cisco system. The agent extension is the agent's phone number extension. This information is pulled from the Cisco telephony system. The caller identifier is the number that the caller called from. If the caller has a restricted number, the caller identifier may read as "caller id", "restricted", or "unknown". The launch call time is the number of seconds after picking up the caller's inquiry that the CSR opens up an instance of the decision support tool. If the workflow is completed by the CSR and a process map endpoint is reached, the end call time field is populated by displaying how many seconds into the call it took to reach the end of the workflow. The terminated call time represents number of seconds that a CSR is on the line with a patient before closing the decision support application. BA_AccountNumber, BA_Campaign, BA_Status, and BA_Response are Cisco Variables obtained through parsing HTML from the Cisco Finesse pop up screen. The ANI is the number that the patient is calling from. The DNIS is the number that the patient was calling to speak to a CSR. The language field displays the language that the call took place in. The Plan ID displays the identifier for the plan that the customer is on. The TIN is the identifier for an account. The AccNum is another account number assigned to the customer, if one does not exist, the field will read "ACC NO: NA". The NPI will

display a number if the caller is a provider who input their national physician identifier, otherwise the field will read "NPI: NA". The LastMenu field displays the last page the patient was on within the IVR menu. The caller type is the field that describes the caller as a patient or provider. The Dept field displays the overall department that the patient was calling for. The department will either display, "CARE", "SPEC" or "BIRD" for primary care departments, specialty departments or billing departments respectively. The TransQueue is the queue that the patient was transferred into before reaching the CSR. The GUID is the globally unique identifier. This is a Cisco variable. While there can be multiple contact identifiers for one call because a CSR can open the application multiple times during the call, there is only one GUID for that call. It will allow the user to find the contact and use the associated GUID to review the call audio and visually recorded playback. The error code represents the type of error that brought the caller out of the IVR and into the queue where they explained their scenario with the CSR. In some cases, an error code will not exist for that call. The error description is the verbal description of the error code. It is displaying the reason why the caller was sent to the queue. Again, in some cases, certain calls may not have an error, or an error may not have a description.

CSN	WorkflowCo	Username	Final_StepID	Final_WorkflowID	StartTime	EndTime	TerminationTime	UseDate	CSOAgentID	AgentStat	CallerID	LamchCallTime	EndCallTime	TerminationCallTime	BA_Account#
18300020175410546	N	Cameron	Flowchart: Data 565	1_Start.xlsx	0.453993518318519	0.450914353831852	0.450914353831852	5/4/2017 7:37:24	1830001	aler_id	aler_id	843	843	849	804
183000201754105635	N	Cameron	Flowchart: Data 565	1_Start.xlsx	0.453996048148148	0.450907962962963	0.450907962962963	5/4/2017 7:37:24	1830001	aler_id	aler_id	892	892	892	904
183000201754105849	N	Cameron	Flowchart: Data 565	1_Start.xlsx	0.457511574024074	0.457731481481481	0.457731481481481	5/4/2017 7:37:24	1830001	aler_id	aler_id	1026	1026	1046	1046
18300020175411018	N	Cameron	Flowchart: Data 565	1_Start.xlsx	0.458516666666667	0.458703703703704	0.458703703703704	5/4/2017 7:37:24	1830001	aler_id	aler_id	1115	1115	1121	1130
18300020175411143	N	Cameron	Flowchart: Data 565	1_Start.xlsx	0.459525462962963	0.459756944444444	0.459756944444444	5/4/2017 7:37:24	1830001	aler_id	aler_id	1201	1201	1221	1221
183000201754114555	N	Cameron	Flowchart: Decision 15	1_Start.xlsx	0.490219907407407	0.494131944444444	0.494131944444444	5/4/2017 7:37:24	1830001	aler_id	aler_id	30	30	369	369
183000201751114631	N	Alexandre	Flowchart: Decision 223	1_Start.xlsx	0.490836374024074	0.492180029292929	0.492180029292929	5/1/2017 7:37:24	1830001	4	4	6999	6999	6999	6999
183000201751160329	N	Alexandre	Flowchart: Decision 27	1_Start.xlsx	0.705196792929293	0.705691722222222	0.705691722222222	5/1/2017 7:37:24	1830001	4	4	4466	4466	4466	4466
18300020175115553	N	Alexandre	Flowchart: Decision 85	1_Start.xlsx	0.663217592929293	0.663321759292929	0.663321759292929	5/1/2017 7:37:24	1830001	4	4	778	778	788	788
183000201751180712	N	Alexandre	Flowchart: Decision 85	1_Start.xlsx	0.685555555555556	0.6871962962963	0.6871962962963	5/1/2017 7:37:24	1830001	4	4	2708	2708	2844	2844
183000201754115156	N	Cameron	Flowchart: Process 11	1_Start.xlsx	0.494398148148148	0.4946048148148	0.4946048148148	5/4/2017 7:37:24	1830001	aler_id	aler_id	392	392	410	410
183000201754115240	N	Cameron	Flowchart: Process 11	1_Start.xlsx	0.494904074074074	0.495011574074074	0.495011574074074	5/4/2017 7:37:24	1830001	aler_id	aler_id	435	435	445	445
18300020175412119	N	Cameron	Flowchart: Process 18	1_Start.xlsx	0.500798611111111	0.503429292929293	0.503429292929293	5/4/2017 7:37:24	1830001	4	4	945	945	1172	1172
1830002017511602	Y	Alexandre	Flowchart: Terminator 13	1_Start.xlsx	0.66688884814815	0.667547222222222	0.667547222222222	5/1/2017 7:37:24	1830001	4	4	1079	1152	1364	1373
18300020175110311	Y	Alexandre	Flowchart: Terminator 13	1_Start.xlsx	0.669138796296297	0.669884292929293	0.669884292929293	5/1/2017 7:37:24	1830001	4	4	1288	1384	1491	1531
18300020175116655	Y	Alexandre	Flowchart: Terminator 13	1_Start.xlsx	0.674699074074074	0.674689814814815	0.674689814814815	5/1/2017 7:37:24	1830001	4	4	1491	1511	1531	1538
18300020175116953	Y	Alexandre	Flowchart: Terminator 13	1_Start.xlsx	0.673530029292929	0.673935185185185	0.673935185185185	5/1/2017 7:37:24	1830001	4	4	1669	1705	1705	1712
18300020175411339	Y	Cameron	Flowchart: Terminator 13	1_Start.xlsx	0.475578703703704	0.4763978703703703	0.4763978703703703	5/4/2017 7:37:24	1830001	aler_id	aler_id	2587	2651	2683	2683
183000201754112450	Y	Cameron	Flowchart: Terminator 13	1_Start.xlsx	0.476701388888889	0.476701388888889	0.476701388888889	5/4/2017 7:37:24	1830001	aler_id	aler_id	2605	2605	3059	3102
18300020175411339	Y	Cameron	Flowchart: Terminator 13	1_Start.xlsx	0.481701388888889	0.481701388888889	0.481701388888889	5/4/2017 7:37:24	1830001	aler_id	aler_id	3117	3117	3369	3712
18300020175115505	Y	Alexandre	Flowchart: Terminator 13	1_Start.xlsx	0.697800292929293	0.660318194444444	0.660318194444444	5/1/2017 7:37:24	1830001	4	4	481	481	533	538
183000201754115453	Y	Cameron	Flowchart: Terminator 13	1_Start.xlsx	0.696467929292929	0.697984074074074	0.697984074074074	5/4/2017 7:37:24	1830001	aler_id	aler_id	568	625	625	695
183000201754115405	Y	Cameron	Flowchart: Terminator 13	1_Start.xlsx	0.699113194444444	0.699282407407407	0.699282407407407	5/4/2017 7:37:24	1830001	aler_id	aler_id	801	814	814	825
18300020175515498	Y	Alexandre	Flowchart: Terminator 13	1_Start.xlsx	0.6992100703703703	0.662118055555556	0.662986111111111	5/5/2017 7:37:24	1830001	aler_id	aler_id	36	296	296	371
183000201753153717	Y	Alexandre	Flowchart: Terminator 13	1_Start.xlsx	0.664701666666667	0.667594444444444	0.667594444444444	5/5/2017 7:37:24	1830001	aler_id	aler_id	9	251	251	810
18300020175111427	Y	Cameron	Flowchart: Terminator 13	1_Start.xlsx	0.497591026185185	0.497591026185185	0.497591026185185	5/1/2017 7:37:24	1830001	aler_id	aler_id	16	190	190	203
183000201751114652	Y	Cameron	Flowchart: Terminator 13	1_Start.xlsx	0.492188185181818	0.493556944444444	0.494884029292929	5/1/2017 7:37:24	1830001	aler_id	aler_id	27	134	134	253

Figure 7: Contact Table Part 1

BA_Campalg	BA_Status	BA_Respovr	ANI	DNIS	LANG	CurPhone	PlanID	TIN	AccNO	AuthStatus	NPI	LastMenu	CallerType	DEPT	TransQueue	GUID	ErrorCode	ErrorDesc
			9143	9143	ENG	NA	PLANID-NA	TIN-NA	ACC NO-NA	AUTH-NA	NP-NA	OPERATOR Con NA	NA	SPEC	PFC_J_B8C0C0C0C0E 1013			PHONO MIS
			9143	9143	ENG	NA	PLANID-NA	TIN-NA	ACC NO-NA	AUTH-NA	NP-NA	OPERATOR Con NA	NA	SPEC	PFC_J_B8C0C0C0C0E 1013			PHONO MIS
			9143	9143	ENG	NA	PLANID-NA	TIN-NA	ACC NO-NA	AUTH-NA	NP-NA	OPERATOR Con NA	NA	SPEC	PFC_J_B8C0C0C0C0E 1013			PHONO MIS
			9143	9143	ENG	4556028700	PLANID-NA	TIN-NA	ACC NO-051221	AUTH-NA	NP-NA	Verify Member NA	NA	SPEC	PFC_J_AF8A91B031710			PHONO MIS
			9143	9143	ENG	NA	PLANID-NA	TIN-NA	ACC NO-NA	AUTH-NA	NP-NA	BOE_Main_Me NA	NA	NA	HED_E5170884A2D00 NA			NA
			9143	9143	ENG	NA	PLANID-NA	TIN-NA	ACC NO-NA	AUTH-NA	NP-NA	BOE_Main_Me NA	NA	NA	HED_E5170884A2D00 NA			NA
			9143	9143	ENG	4556028700	PLANID-NA	TIN-NA	ACC NO-051221	AUTH-NA	NP-NA	Verify Member NA	NA	SPEC	PFC_J_AF8A91B031710			SUCCESS
			9143	9143	ENG	4556028700	PLANID-NA	TIN-NA	ACC NO-051221	AUTH-NA	NP-NA	Verify Member NA	NA	SPEC	PFC_J_AF8A91B031710			SUCCESS
			9143	9143	ENG	NA	PLANID-NA	TIN-NA	ACC NO-NA	AUTH-NA	NP-NA	BOE_Main_Me NA	NA	NA	HED_E5170884A2D00 NA			NA
			9143	9143	ENG	NA	PLANID-NA	TIN-NA	ACC NO-NA	AUTH-NA	NP-NA	BOE_Main_Me NA	NA	NA	HED_E5170884A2D00 NA			NA
			9143	9143	ENG	NA	PLANID-NA	TIN-NA	ACC NO-NA	AUTH-NA	NP-NA	BOE_Main_Me NA	NA	NA	HED_E5170884A2D00 NA			NA
			9143	9143	ENG	4556028700	PLANID-NA	TIN-NA	ACC NO-051221	AUTH-NA	NP-NA	Verify Member NA	NA	SPEC	PFC_J_B8C0C0C0C0E 1013			PHONO MIS
			9143	9143	ENG	NA	PLANID-NA	TIN-NA	ACC NO-NA	AUTH-NA	NP-NA	OPERATOR Con NA	NA	SPEC	PFC_J_B8C0C0C0C0E 1013			PHONO MIS
			9143	9143	ENG	NA	PLANID-NA	TIN-NA	ACC NO-NA	AUTH-NA	NP-NA	BOE_Main_Me NA	NA	NA	HED_E5170884A2D00 NA			NA
			9143	9143	ENG	4556028700	PLANID-NA	TIN-NA	ACC NO-051221	AUTH-NA	NP-NA	Verify Member NA	NA	SPEC	PFC_J_AF8A91B031710			SUCCESS
			9142	9143	ENG	4556028700	PLANID-NA	TIN-NA	ACC NO-051221	AUTH-NA	NP-NA	Verify Member NA	NA	SPEC	PFC_J_AF8A91B031710			SUCCESS
			9143	9143	ENG	NA	PLANID-NA	TIN-NA	ACC NO-NA	AUTH-NA	NP-NA	Collect Phone # NA	NA	SPEC	PFC_J_080A3E81041 1013			PHONO MIS
			9143	9143	ENG	4556028700	PLANID-NA	TIN-NA	ACC NO-051221	AUTH-NA	NP-NA	Verify Member NA	NA	SPEC	PFC_J_6488FBF359710			SUCCESS
			9143	9143	ENG	NA	PLANID-NA	TIN-NA	ACC NO-NA	AUTH-NA	NP-NA	Collect Phone # NA	NA	SPEC	PFC_J_47DA12735981 1013			PHONO MIS

Figure 8: Contact Table Part 2

3.2.3 Process Step Table

The process step table contains ten fields. The PSN is unique the process step number. Each contact consists of one or more processes. There is a one to many relationships between a contact and a process respectively. The step id is the name of the step within the workflow that the CSR was in when the data was collected. The CSN is the contact number. This is the foreign key within the process step table. The workflow identifier is the name of the workflow file that the decision support tool was pulling from during the process. The start time and end time are the timestamps that represent when the process started and ended respectively. The call time start is the time the CSR has been speaking with the patient when the process step started. The call time end is the time the CSR has been speaking with the patient when the process step ended. The “this step back” field shows if the CSR went back or forward through the workflow. If the CSR went forward the “this step back” field will display “N”. If the CSR went backwards through the process, the “this step back” field will display “Y”. The state field displays if the CSR is talking, on hold, or which idle the CSR is using. The time in state field is a calculated field that displays the difference between the end time field and start time field.

PSN	StepID	CSN	WorkflowID	StartTime	EndTime	CallTimeStart	CallTimeEnd	ThisStepBack	State	TimeInState
183200120175116953	Flowchart: Data 103	183200120175116953		Start.xls 0.673541666666667	0.673541666666667	1671	1671 N		Talking	
1832001201751155523	Flowchart: Data 103	183200120175115552		Start.xls 0.663229166666667	0.663229166666667	780	780 N			
183200120175116023	Flowchart: Data 103	18320012017511602		Start.xls 0.666701388888889	0.666701388888889	1080	1080 N		Talking	
1832001201751163313	Flowchart: Data 103	183200120175116331		Start.xls 0.669131944444444	0.669131944444444	1290	1290 N		Talking	
1832001201751166553	Flowchart: Data 103	183200120175116655		Start.xls 0.671493055555556	0.671493055555556	1493	1493 N		Talking	
18320012017511627123	Flowchart: Data 103	1832001201751162712		Start.xls 0.685636574074074	0.685636574074074	2715	2715 N		Talking	
18320012017511655293	Flowchart: Data 103	1832001201751165529		Start.xls 0.705266203703704	0.705266203703704	4412	4412 N		Talking	
18320012017541055463	Flowchart: Data 103	1832001201754105546		Start.xls 0.455428240740741	0.455428240740741	847	847 N		Talking	
18320012017541056353	Flowchart: Data 103	1832001201754105635		Start.xls 0.455983796296296	0.455983796296296	895	895 N		Talking	
18320012017541058493	Flowchart: Data 103	1832001201754105849		Start.xls 0.457523148148148	0.457523148148148	1028	1028 N		Talking	
1832001201754110183	Flowchart: Data 103	183200120175411018		Start.xls 0.458564814814815	0.458564814814815	1118	1118 N		Talking	
1832001201754111433	Flowchart: Data 103	183200120175411143		Start.xls 0.459548611111111	0.459548611111111	1203	1203 N		Talking	
18320012017541124503	Flowchart: Data 103	1832001201754112450		Start.xls 0.475601851851852	0.475601851851852	2590	2590 N		Talking	
18320012017541126273	Flowchart: Data 103	1832001201754112627		Start.xls 0.476736111111111	0.476736111111111	2688	2688 N		Talking	
1832001201751146313	Flowchart: Data 103	183200120175114631		Start.xls 0.49068287037037	0.49068287037037	7004	7004 N		Talking	
1832001201751155053	Flowchart: Data 103	183200120175115505		Start.xls 0.659791666666667	0.659791666666667	483	483 N			
18320012017541133393	Flowchart: Data 103	1832001201754113339		Start.xls 0.481736111111111	0.481736111111111	3120	3120 N			
18320012017551557173	Flowchart: Data 103	1832001201755155717		Start.xls 0.664849537037037	0.664849537037037	15	15 N		Talking	
18320012017511148523	Flowchart: Data 103	1832001201751114852		Start.xls 0.492303240740741	0.492303240740741	30	30 N		Talking	
18320012017541124505	Flowchart: Data 565	1832001201754112450		Start.xls 0.475636574074074	0.475636574074074	2593	2593 N		Talking	
18320012017541133395	Flowchart: Data 565	1832001201754113339		Start.xls 0.481770833333333	0.481770833333333	3123	3123 N		Talking	
18320012017551557175	Flowchart: Data 565	1832001201755155717		Start.xls 0.664988425925296	0.665219907407407	27	48 N		Talking	
18320012017541124506	Flowchart: Data 568	1832001201754112450		Start.xls 0.475659722222222	0.475659722222222	2595	2595 N		Talking	
18320012017541133396	Flowchart: Data 568	1832001201754113339		Start.xls 0.481828703703704	0.481828703703704	3128	3128 N		Talking	
18320012017551557176	Flowchart: Data 568	1832001201755155717		Start.xls 0.665231481481481	0.665231481481481	48	49 N		Talking	
1832001201751169532	Flowchart: Data 59	183200120175116953		Start.xls 0.673541666666667	0.673541666666667	1670	1670 N		Talking	
183200120175116022	Flowchart: Data 59	18320012017511602		Start.xls 0.666701388888889	0.666701388888889	1080	1080 N		Talking	
1832001201751163312	Flowchart: Data 59	183200120175116331		Start.xls 0.669131944444444	0.669131944444444	1290	1290 N		Talking	
1832001201751166552	Flowchart: Data 59	183200120175116655		Start.xls 0.671481481481481	0.671481481481481	1493	1493 N		Talking	
18320012017511627122	Flowchart: Data 59	1832001201751162712		Start.xls 0.685625	0.685625	2715	2715 N		Talking	
18320012017511655292	Flowchart: Data 59	1832001201751165529		Start.xls 0.705266203703704	0.705266203703704	4412	4412 N		Talking	
18320012017541055462	Flowchart: Data 59	1832001201754105546		Start.xls 0.455428240740741	0.455428240740741	847	847 N		Talking	
18320012017541056352	Flowchart: Data 59	1832001201754105635		Start.xls 0.455972222222222	0.455972222222222	894	894 N		Talking	
18320012017541058492	Flowchart: Data 59	1832001201754105849		Start.xls 0.457523148148148	0.457523148148148	1028	1028 N		Talking	
1832001201754110182	Flowchart: Data 59	183200120175411018		Start.xls 0.458564814814815	0.458564814814815	1118	1118 N		Talking	
1832001201754111432	Flowchart: Data 59	183200120175411143		Start.xls 0.459537037037037	0.459537037037037	1203	1203 N		Talking	

Figure 9: Process Detail Table

3.2.4 Crisis Workflow Launcher

In a contact center environment, while rare, a patient or customer can exhibit signs that show they are in crisis. Two examples of a patient in crisis is a patient going through an urgent health related episode or a patient threatening to commit suicide. As a precaution, in the event of a crisis, a Crisis Workflow Launch Button is hardcoded in the GUI. When a patient is in crisis, a CSR can quickly click the Crisis button. The workflow immediately changes to the crisis workflow which guides the CSR through this rare and difficult patient experience ensuring standardization on how these events are handled and that the patient experiences the proper care they need to find the best outcome based on their scenario.

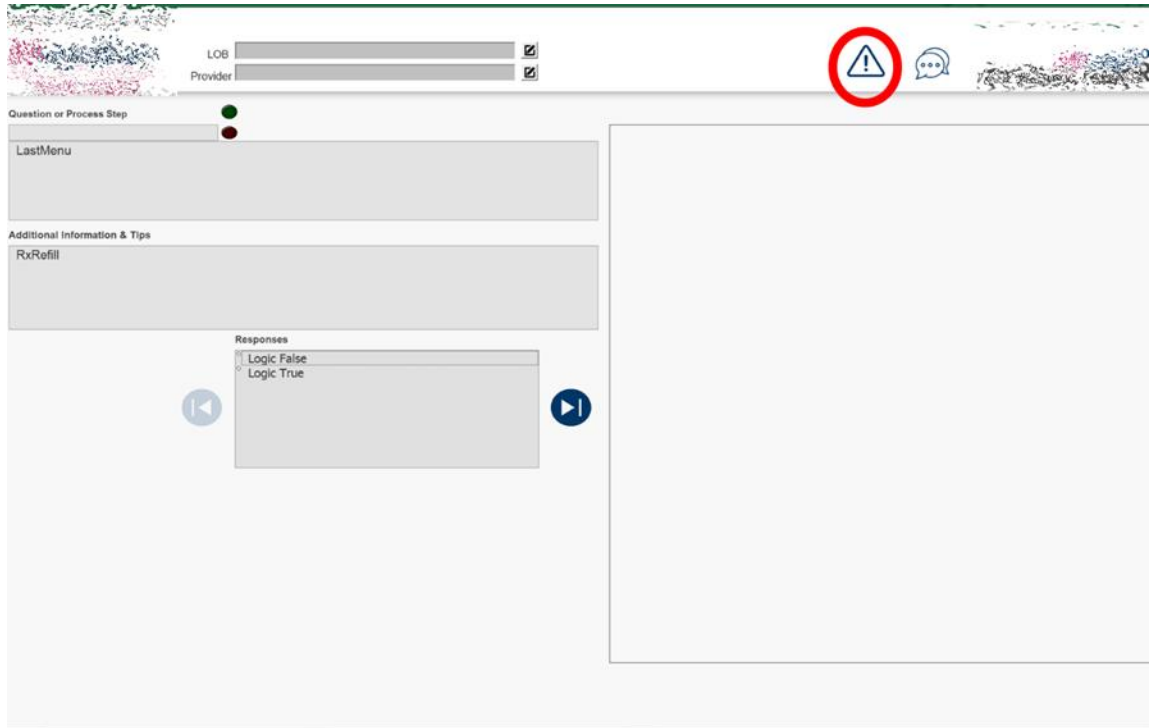

Figure 10: Crisis Workflow Launcher Button

3.2.5 Spanish Call Alert

In the studied contact center, the IVR software system allows the customer to choose to speak to a CSR in Spanish or in English. However, to reduce the wait time for Spanish callers and to even out the workload between English and Spanish speaking CSRs, a Spanish speaking patient may be routed to an English-speaking CSR. To properly handle the patient's requests in their preferred language, the English-speaking CSR utilizes a third-party translation services group. To do this, the CSR will call this third-party translation services group and the patient will talk to the translation services third party while the translation services third party will translate the patient's information to English for the CSR and vice versa. Currently, the CSR needs to review the Cisco Finesse screen pop information to know if the patient will be speaking in Spanish or English. If the CSR is

using the contact center’s developed decision support tool, the patient will know if the patient will be speaking Spanish because a blinking red light as well as a blinking text box labeled “Spanish Call” will display on the screen. This identifies the preferred language of the call without the CSR needing to ask the patient and without the need to review the Cisco Finesse screen pop. This feature will reduce the cognitive workload for both Spanish and English-speaking CSRs while speaking with a Spanish speaking patient.

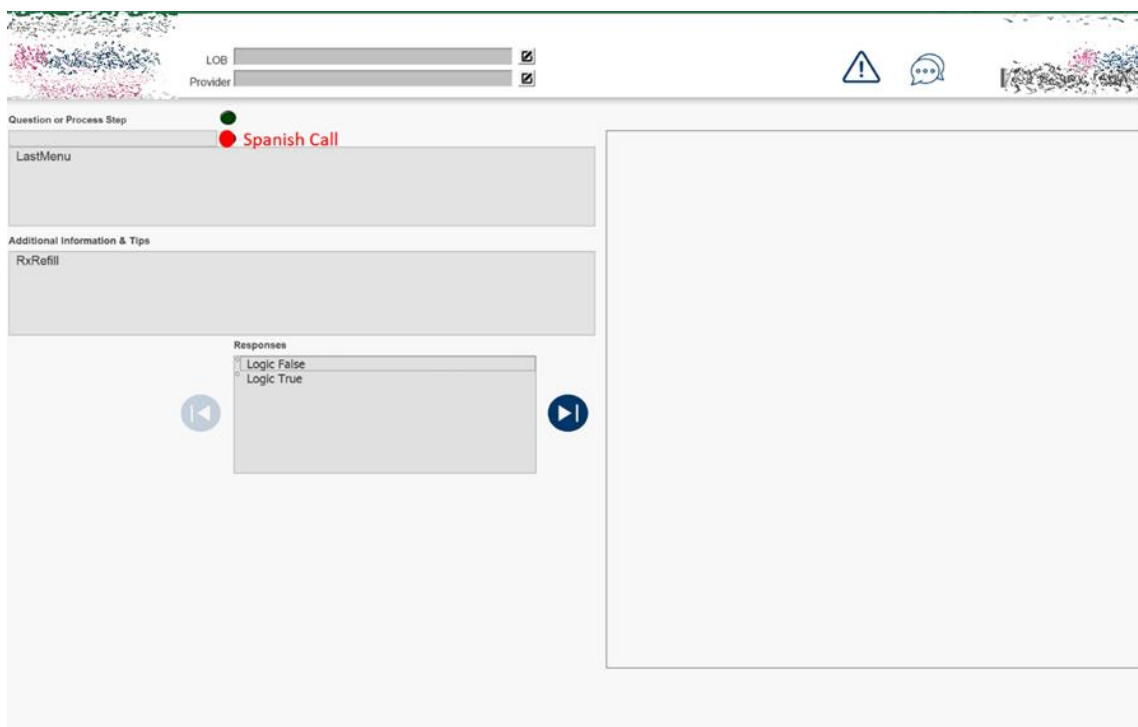

Figure 11: Spanish Call Signaling

If a patient chooses to speak Spanish to a CSR, reading the decision support tool in English and then translating the information into Spanish may be a more cognitively demanding task than reading from the GUI in Spanish and speaking Spanish to the patient.

If time allows, future customizability to allow a CSR to fluidly switch between an English and Spanish GUI may provide better quality and more accurate delivery of service.

3.2.6 Autologic and IVR Call Data Interpretation

The IVR collects information about what the patient is calling about and helps route the patient to the correct queue within the contact center. In most cases, each CSR is skilled to handle multiple different types of patient inquiries from different queues. In rare cases, CSRs are trained to handle calls from different lines of businesses. Often in these cases, a CSR is trained in two relatively similar queues that handle similar inquiries but contain nuances like servicing different physicians. In these cases, especially, it is important for a CSR to gain context about what the patient is inquiring and what the patient was attempting to achieve in the IVR system. Understanding the attempts of the patient can provide key insight on the root cause of the call. If the root cause of the call is identified early, the CSR can likely handle the call at a quicker pace, and the first resolution rate will likely improve along with customer satisfaction (I. Editors, 2011). Currently, to provide a level of context, the Cisco system provides a Finesse screen pop at the start of each call. A Finesse screen pop is a pop-up instance of Internet Explorer. Within the internet explorer instance, information regarding the caller and what the caller was attempting to achieve within the IVR system appears towards the bottom of the screen. The IVR system is a hardcoded decision tree-based system. The patient can only achieve or attempt to achieve a limited number of goals. Hence, the Finesse screen pop can provide high-level context on these attempts. For example, if the patient attempts to refill a prescription, but fails out of the IVR system and is sent to a CSR, the Finesse system will read “RxRefill” or prescription

refill attempt as the patient's last menu accessed. From the CSR perspective, knowing this information is important because they can switch modalities to focus on prescription renewal as soon as they receive the call and review the Finesse screen. One drawback to using the Finesse screen is that the CSR needs to decipher the meaning of the Finesse screen. They need to study the nuances and memorize the Finesse codes and meaning of each code to fully gain the high-level context that the Finesse system is outputting. To enhance the functionality of the decision support system and to help the CSR gain context, Finesse screen analysis is developed into the decision support tool's system.

To achieve this level of context, three pieces of the decision support tool were developed. The first piece of the decision support tool is code that looks for an open instance of internet explorer opened to the Cisco Finesse website. If the instance is found, the code parses the HTML to extract Cisco variables related to the patient's call from the IVR system. These Cisco variables are stored as global variables within the decision support tool. This piece of the decision support tool extracts the IVR and patient information from the Finesse system. The next piece of the decision support tool is the auto-logic workflow. This workflow can be added to or edited by a workflow developer. This checks to see if certain variables are equal to certain values. One example is checking if a patient went through the prescription renewal menu within the IVR. To check this, the autologic calculates if the last menu accessed variable is equal to "RxRenewal". The two possible outcomes for a logic workflow step are logic true and logic false. If a complex set of information needs to be determined like "If last item equals "RxRenewal" and patient first name equals "Robert", then do process A otherwise, do process B" multiple logic steps

would need to be reviewed before determining whether process step A or B is the correct path. The following picture illustrates this scenario.

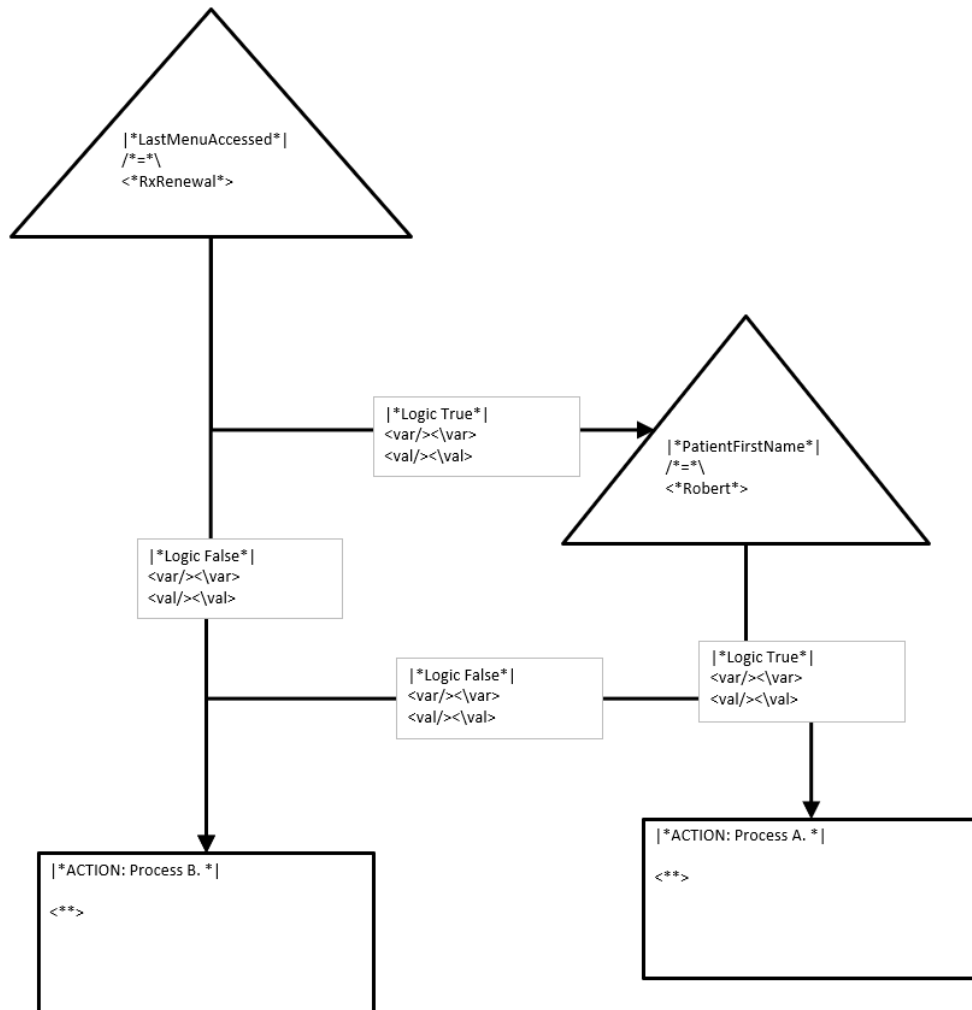

Figure 12: Autologic Example

When this autologic is used to determine what took place in the IVR, automated scripting that utilized the IVR variables can be used to enrich the contextualization from the CSRs perspective. The third piece of the decision support tool that enables this IVR

context is scripting and the use of variables. The line of business is represented as the LOB name. The picture below shows an example of the decision support tool variable scripting.

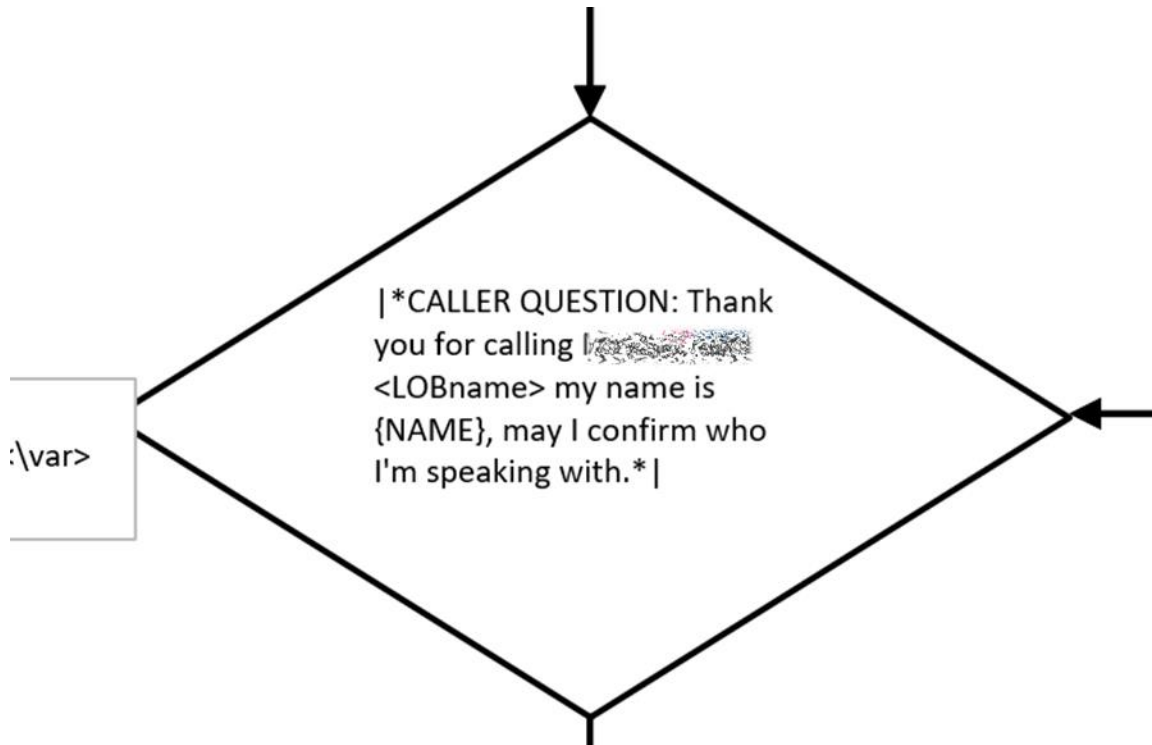

Figure 13: Scripting with Parsed and Stored Finesse Variables

If full centralization is obtained, a universal CSR will not need to review the complicated Finesse screen pop. The decision support tool will parse, extract, and store the Finesse HTML variables. Then, the decision support tool will use a series of autologic processes to determine which workflow the patient is concerned with and which scripted variables to display. As the IVR becomes more complex, the IVR variable list will multiply and the CSR may likely revert to asking the patient what they need help with. However, asking the patient what they need help with may decrease customer satisfaction because

the patient often spends a large amount of time within the IVR system. If a CSR can quickly gain context from the customer's experience within the IVR system, they can more quickly address the needs of the customer.

3.2.7 Handling Transfers

In a transfer, the Cisco Finesse screen will show different variables and the new CSR handling the call may need to be briefed on any activities that took place as not to introduce rework into the system and to facilitate a more positive customer experience.

Churn within a contact center means that new CSRs are continually being trained. To achieve true contact center centralization, a CSR must utilize a decision support tool to become a universal liaison and handle calls and inquiries across all lines of business. New CSRs will need training on how to effectively utilize the decision support tool to achieve the best results. Even if a CSR goes through a training course on how to use the decision support tool, a guideline on how to navigate the tool may be useful.

As new developers use the decision support tool to map, and standardize workflows, it is important to create a developer manual to ensure the developer is using the decision support tool to the tool's highest capacity. Many features and shortcuts were programmed into the decision support tool to make development easier and to make developers more effective while navigating the tool. One example of this is the drilldown submodel functionality. Much like in the Zingtree and Yonyx decision support tools, submodels can be created to store more common and complex decision tree workflows in one area instead of copy and pasting the same workflows multiple times. Using submodels

in a decision support tool can reduce the amount of maintenance when processes and best practices change over time in a dynamic environment like healthcare. The picture below shows a submodel within a decision tree.

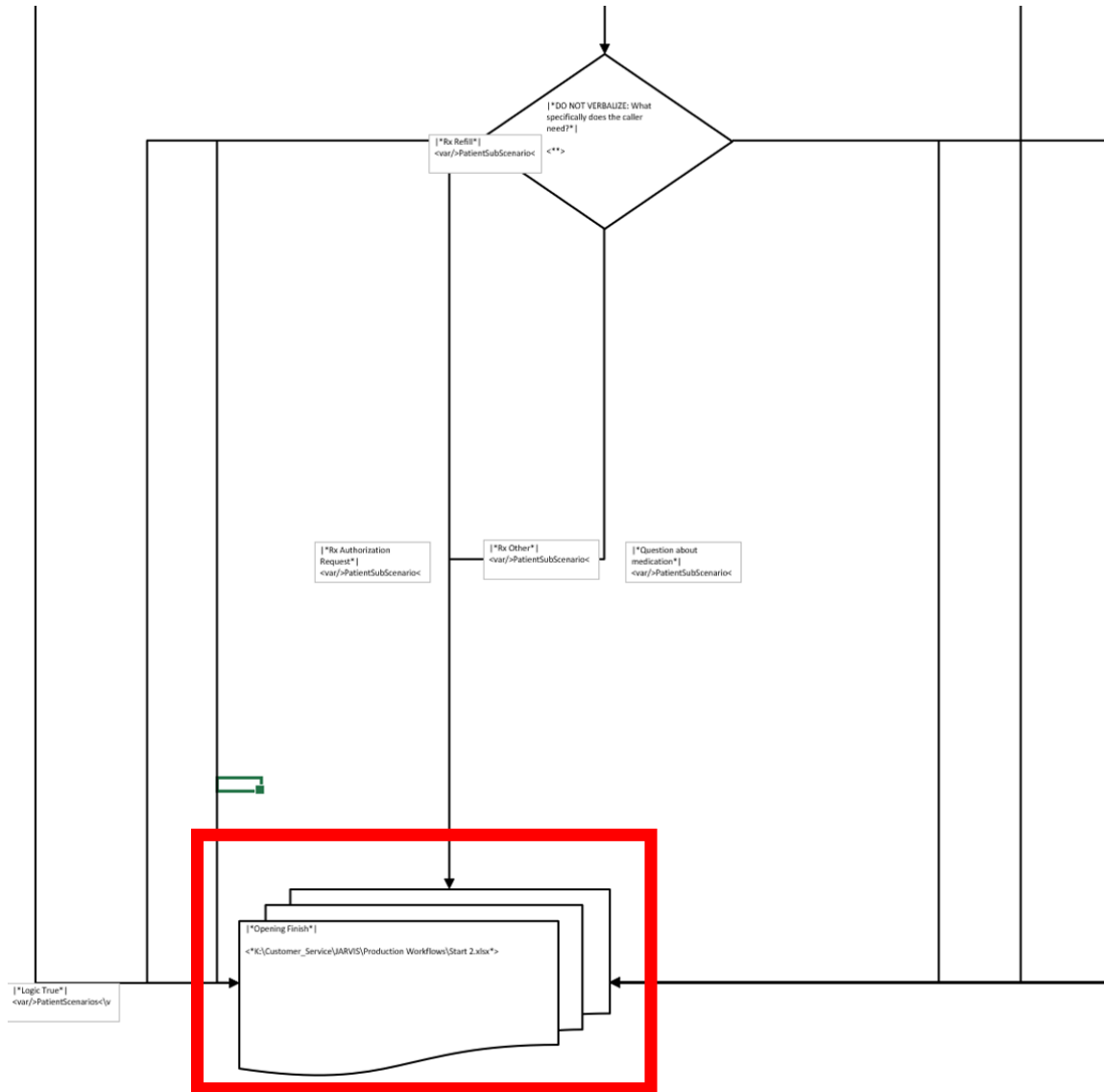

Figure 14: Submodel Within Decision Tree

In some instances, a developer may need to open the next decision tree within the submodel to ensure the flow of the call is accurate before testing. To do this manually, the developer would need to find the file that contains the next submodel and open it. While this may only take a small amount of time, it may de-prioritize the task of ensuring the call flow is appropriate, and if the developer is not diligent, they may forget to check the call workflow process for appropriate flow between models. As Roediger notes, there is a limit to recall within humans (Roediger, 1990). One solution to this problem is to make it easier to open the next submodel using a hotkey shortcut. This feature was developed in the decision support tool. To utilize this feature, the developer clicks on the submodel shape and pressed Ctrl+D on their keyboard. This initiates a VBA module that parses the file path from the shape text and opens the file automatically. Shortcuts and nuances to the decision support software on the back end can help a developer create and manage workflows more efficiently. Thus, as new shortcuts and features are added into the current decision support tool environment, training or updates to training materials should take place. Additionally, each feature should be logged into some form of documentation like a training manual or body of knowledge. Additionally, the developer can utilize the decision support tool to create decisions support based workflows. Each feature could have a specific scenario custom variable using the custom variables tool. Then, to make searching for scenarios easier, the fuzzy search functionality could be used to help a developer navigate through the best practice use of each feature. The lead developer could also collect feedback from other developers when they use the feedback feature, and the feedback is stored within the database.

3.3 Graphical User Interface

This section provides a general understanding of the buttons, alerts and images and other features made accessible by the graphical user interface.

3.3.1 Start Button

When the user wishes to start a call, they must first open the Excel file. To start the call, they must currently have a call routed to their line before pressing start. If they press start before a call is routed into their line, an error will show. Completing this action logs a new contact within the decision support database.

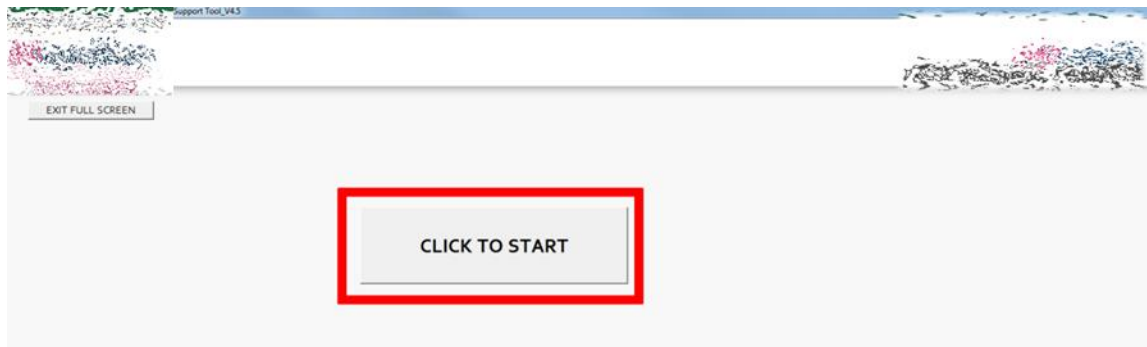

Figure 15: Start Button

3.3.2 Next Button

Many of the screens will need a response before moving on to the next page. If a response is not chosen before hitting the next button and a response is necessary, an error warning will pop up onto the user's screen. The user will be unable to move to the next step without a response chosen.

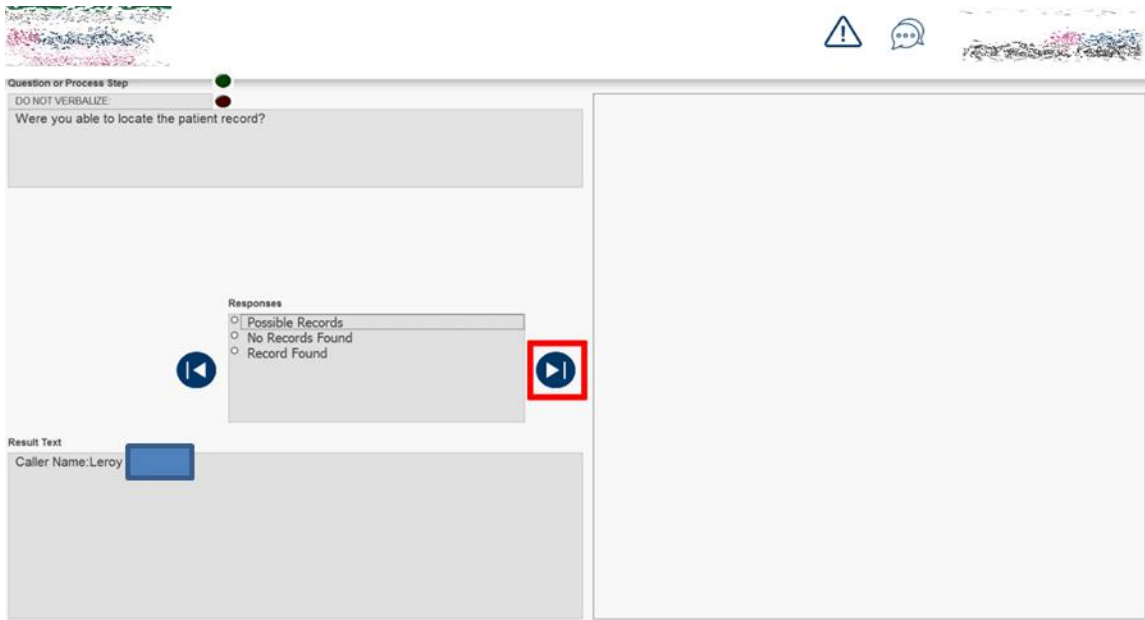

Figure 16: Next Button

3.3.3 Previous Button

The previous button allows the user to go back to the previous step within the workflow. There are twelve variables that log the user's history throughout the workflows. The user can use the previous button a maximum of twelve times in a row.

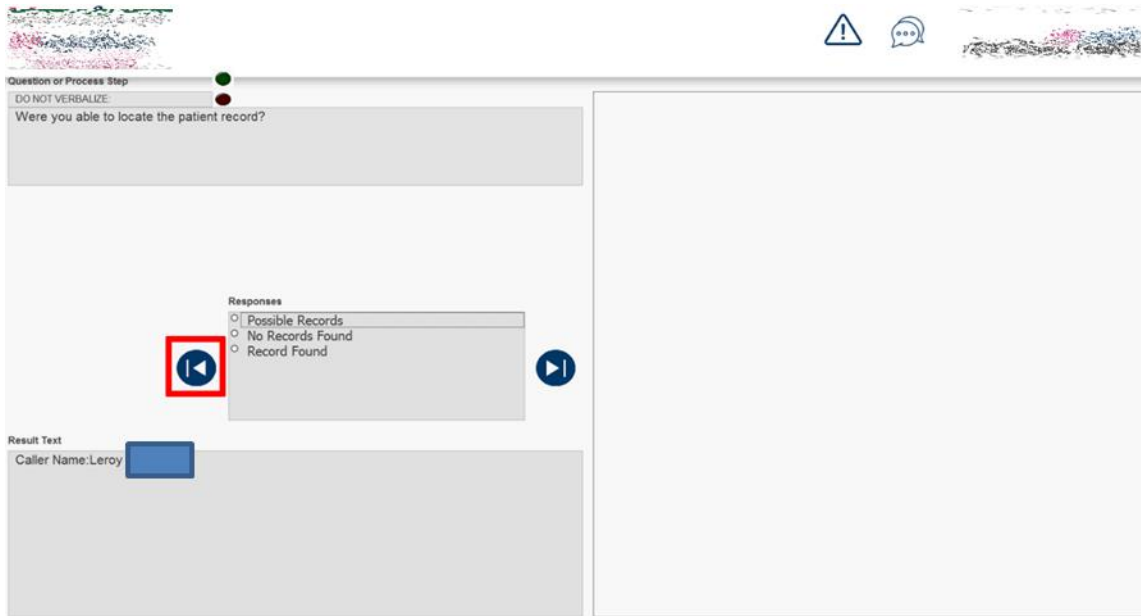

Figure 17: Previous Button

3.3.4 Response Box

To click the next button, the user must select one of the responses. If the user clicks the next button without selecting a response, a warning will pop up reminding the user to select a response.

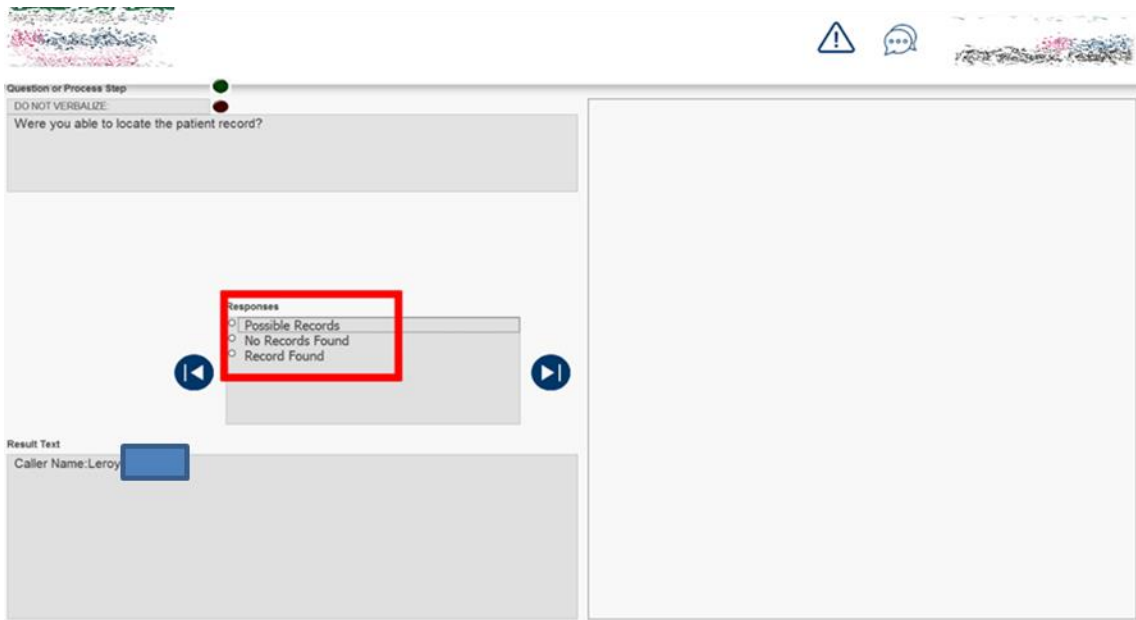

Figure 18: Responses Box

3.3.5 Result Text Box

In some instances, this program may prompt the user to fill in certain variables. These variables are and displayed in the Result Text box. This is especially important for CRM text scripting. When a user fills out information based on the patient's physician, the line of business, and scenario, the decision support tool allows for automatic CRM scripting. The CRM scripting will appear within the result text box and will be automatically copied into the user's clipboard. When the result text is copied into the user's clipboard, a notification will appear that makes the user aware of the addition to their clipboard.

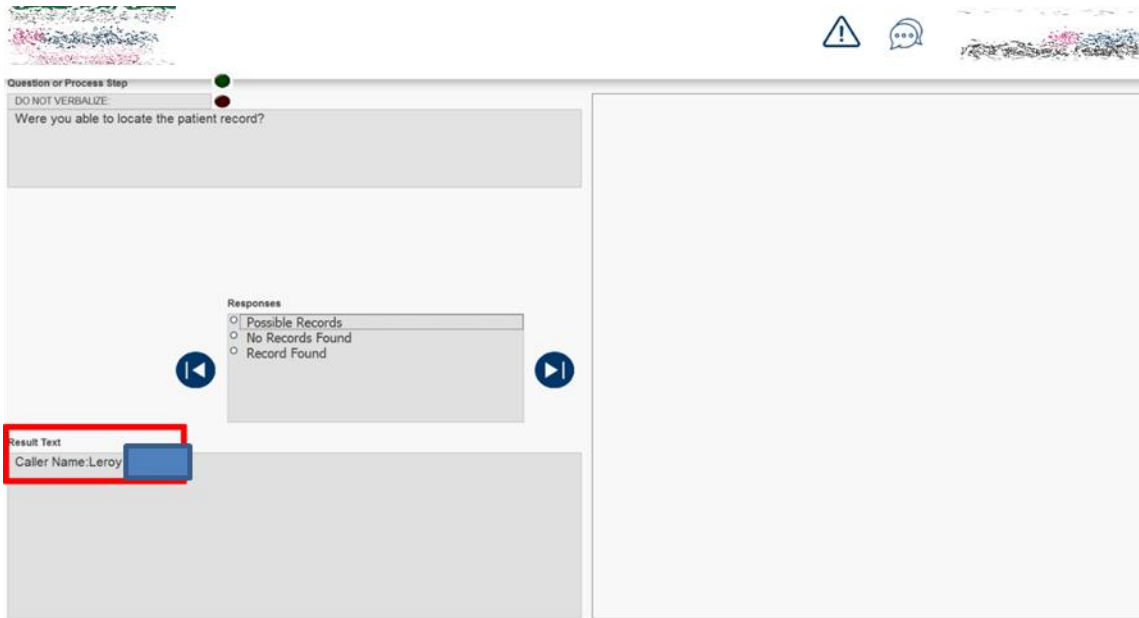

Figure 19: Result Text Box

3.3.6 Call Flow Complete Alert

When the CSR arrives at the end of a workflow and the call flow is complete, a blinking green light will appear.

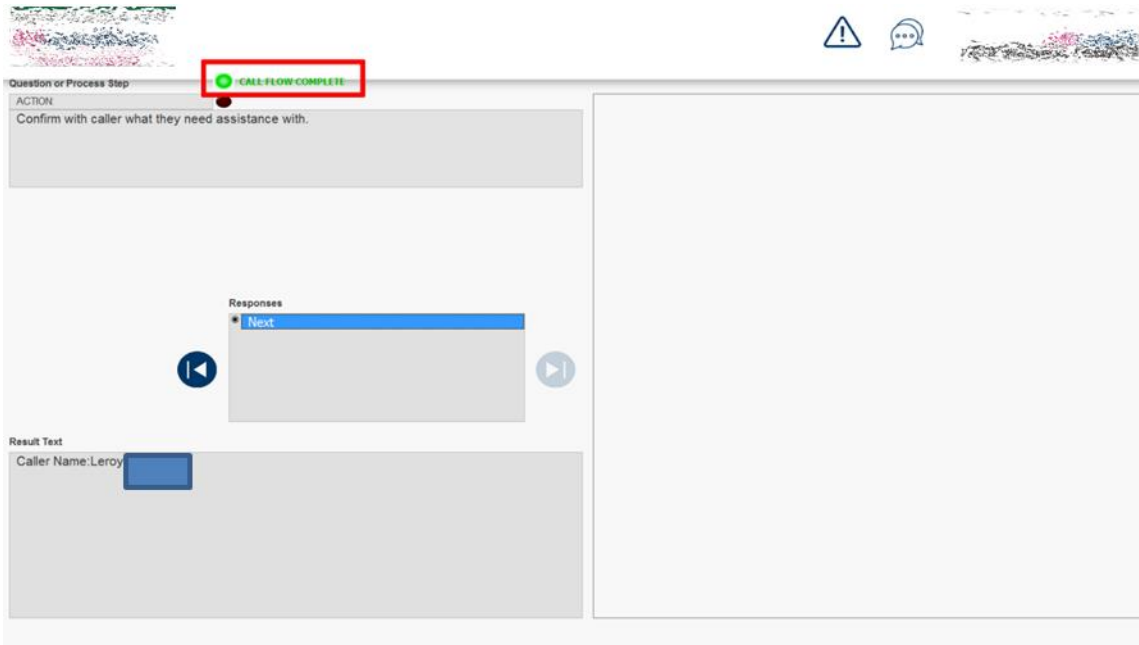

Figure 20: Call Flow Complete Alert

3.3.7 Verbalize to Patient Alert

If the user should verbalize the statement in the question/process step box to the customer, the highlighted box will say “INFORM CALLER” or “ACTION” and the text will be Magenta as shown in the picture below.

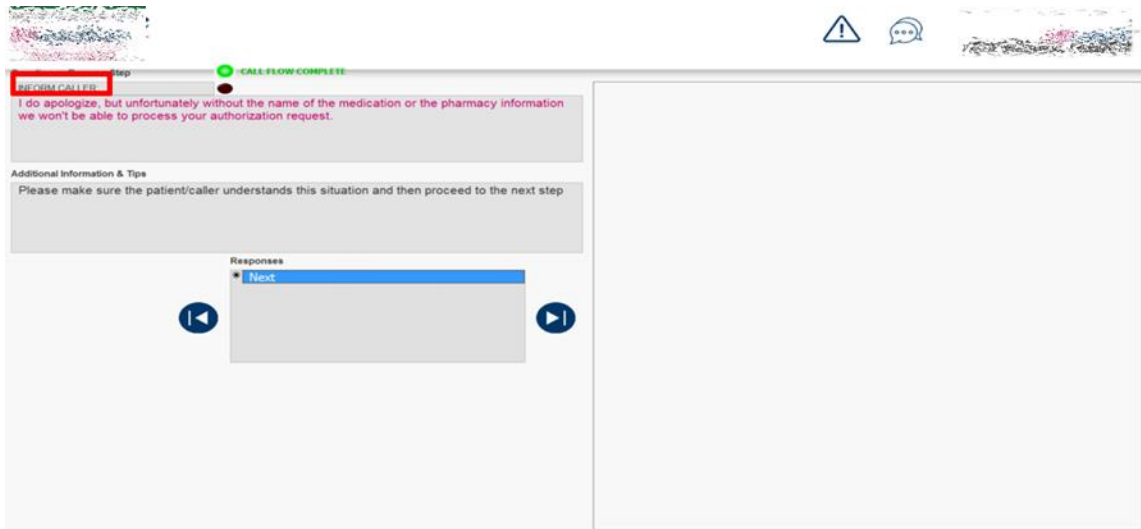

Figure 21: Verbalize to Patient

3.3.8 Do not Verbalize to Patient Alert

If the user should not verbalize the statement in the question/process step box to the customer, the highlighted box will say “DO NOT VERBALIZE” and the text will be Black as shown in the picture below.

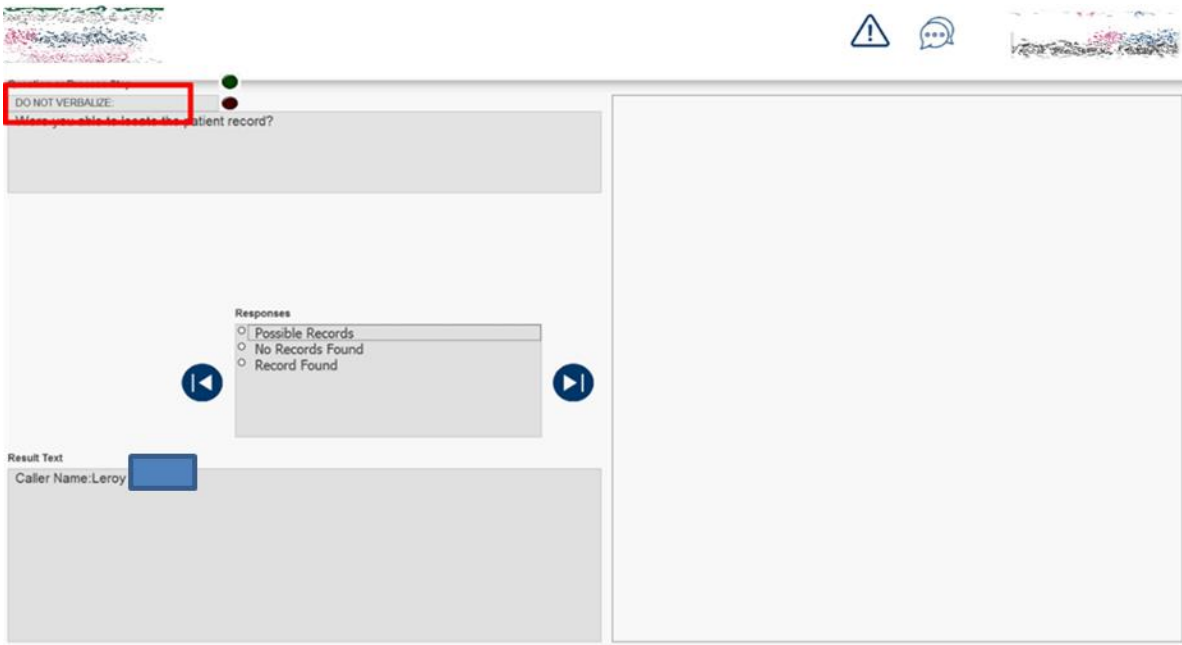

Figure 22: Do Not Verbalize to Patient

3.3.9 Crisis Button

The Crisis button should be clicked when a patient is in crisis. One example of a scenario when the crisis button should be used is when a patient threatens suicide. While these experiences are rare, it is important to be able to act quickly, hence the dedicated button. When this button is clicked, it will automatically launch a workflow guiding the user through the crisis.

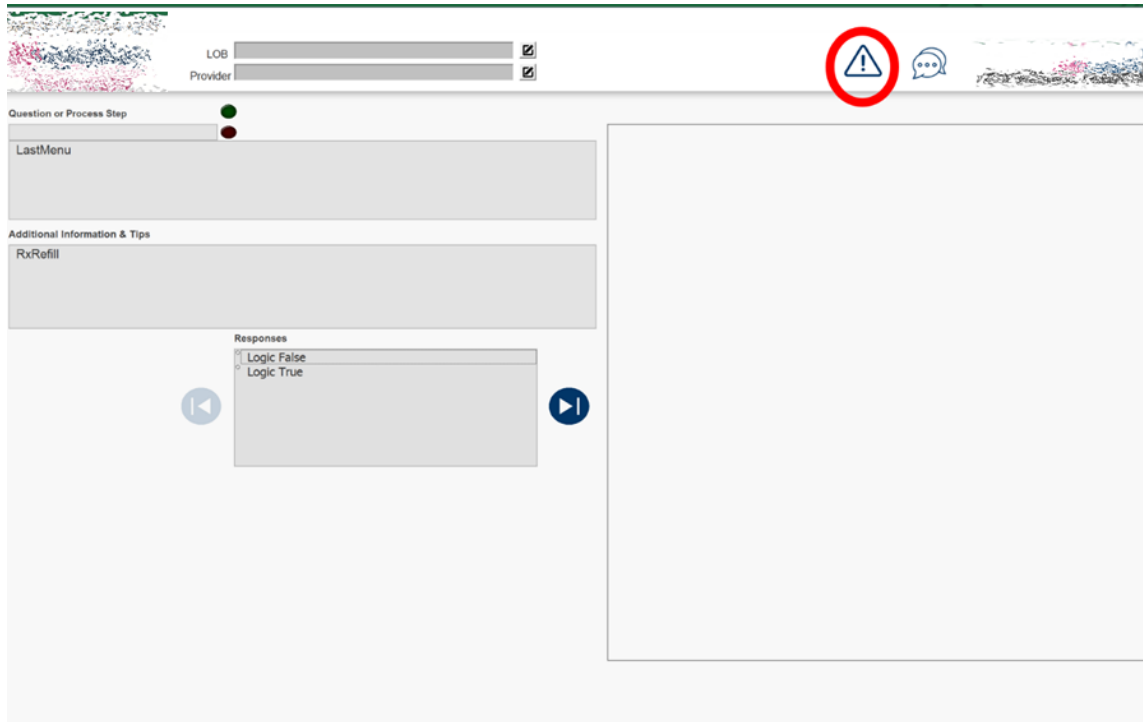

Figure 23: Crisis Workflow Launcher

3.3.10 Feedback Button

For user convenience, a feedback button is placed on the top right side of the screen. When the process is incorrect, or the user has a suggestion for additional features, the user should click on this button and write a detailed description of the system failure before submitting. The decision support database will store any feedback that a user provides.

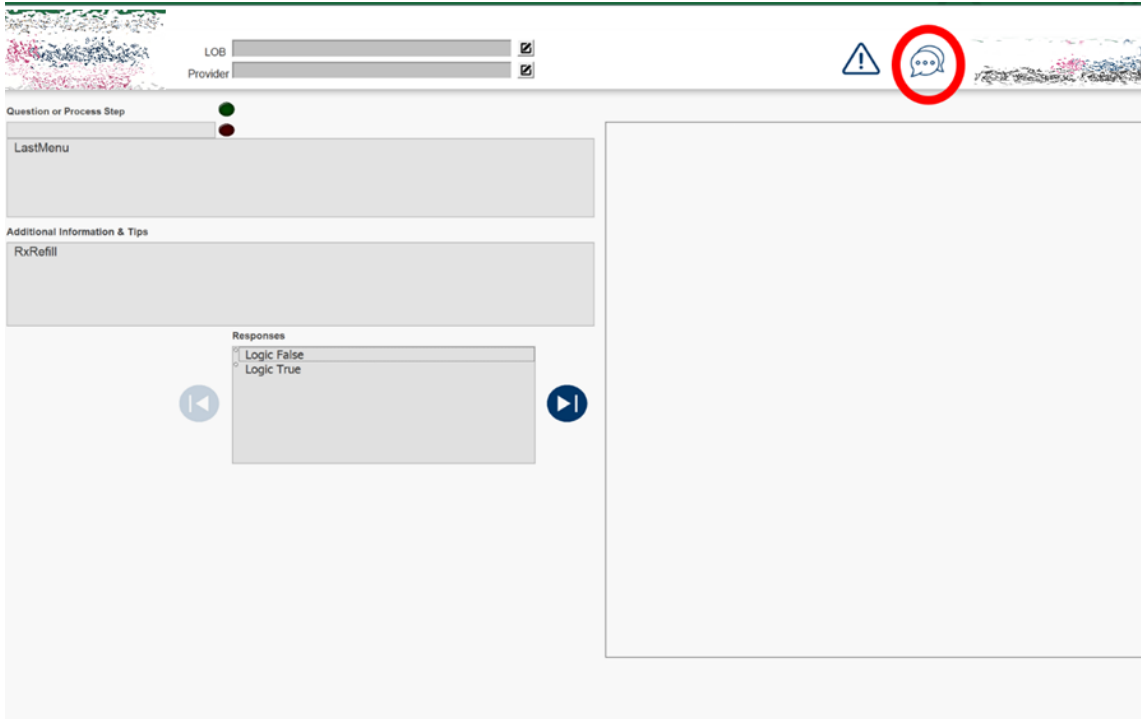

Figure 24: Feedback Button

3.3.11 Spanish Call Alert

The red button on the top left side of the screen alerts the user that the call being received is in Spanish. Decision support variables are parsed from Cisco Finesse HTML. If the language variable reads “Spanish”, this red light and text box will blink.

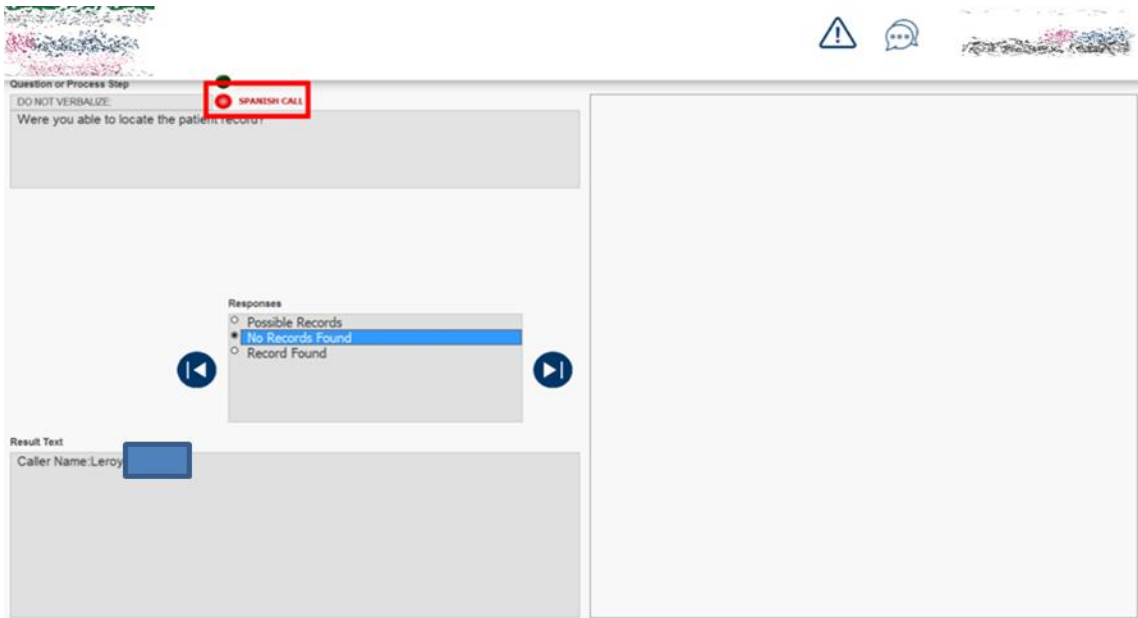

Figure 25: Spanish Call Alert

3.3.12 Support Picture

In certain cases, it may be difficult to remember how to navigate seldom utilized software. In these cases, screenshots of this software will display on the right side of the screen to guide the user in completing the task.

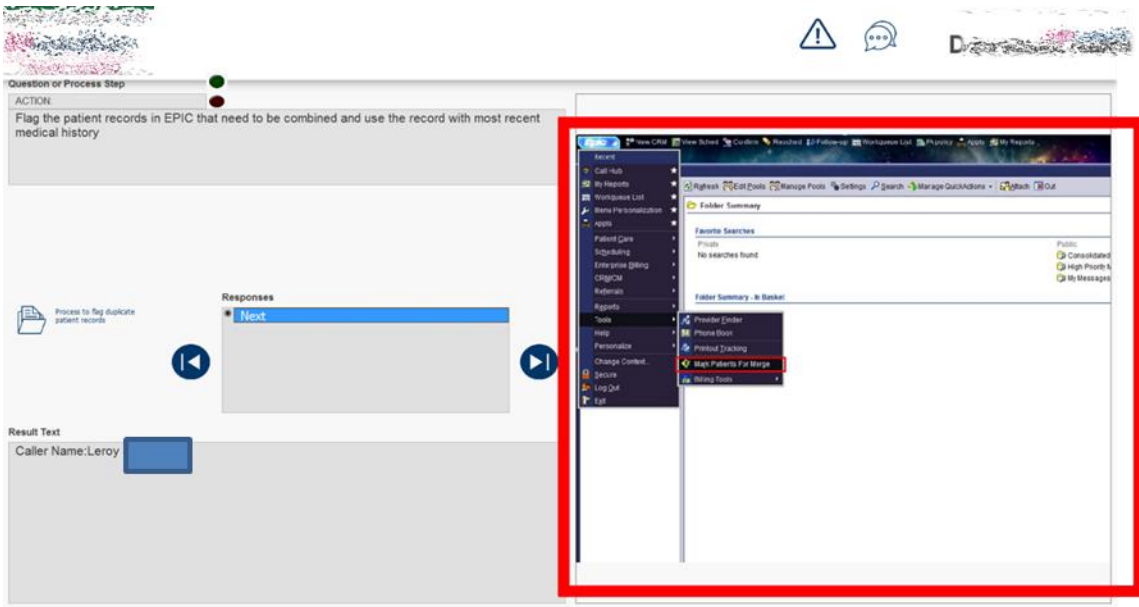

Figure 26: Support Picture

3.3.13 Support Document

In certain cases, it may be difficult to remember how to navigate seldom utilized software. In cases where a support picture is not detailed enough, the document button will appear on the left side of the interface. When this button is clicked, the detailed file is launched on the user's desktop.

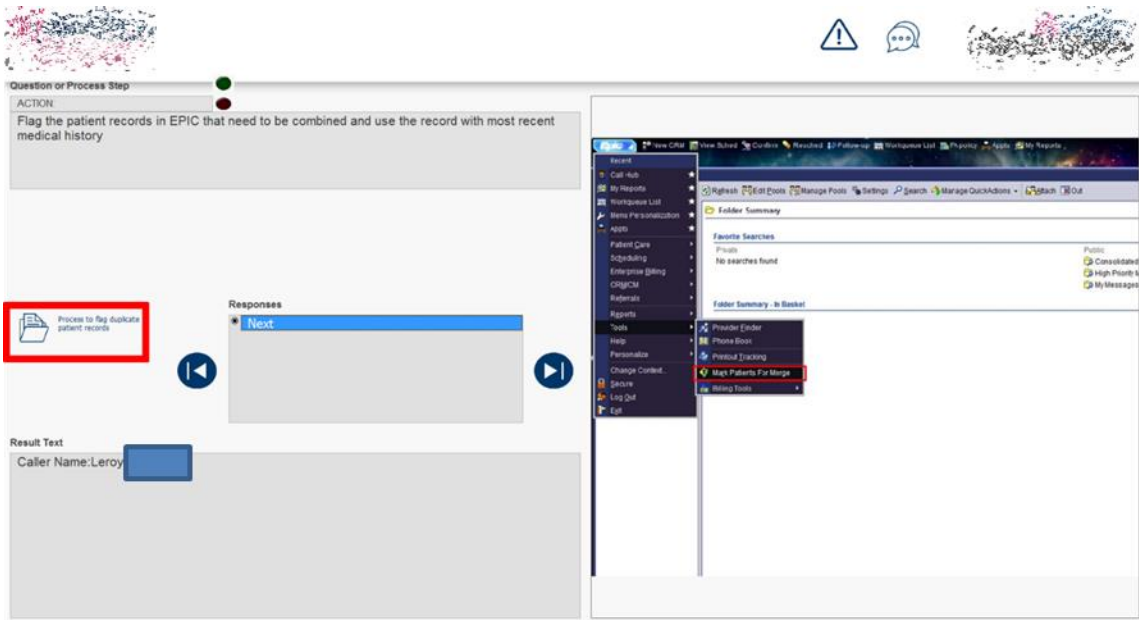

Figure 27: Support Document

3.3.14 Exit System

If the user needs to exit the interface, they should click the exit button on the top right side of the VBA form. This action is logged as a termination of contact within the decision support database.

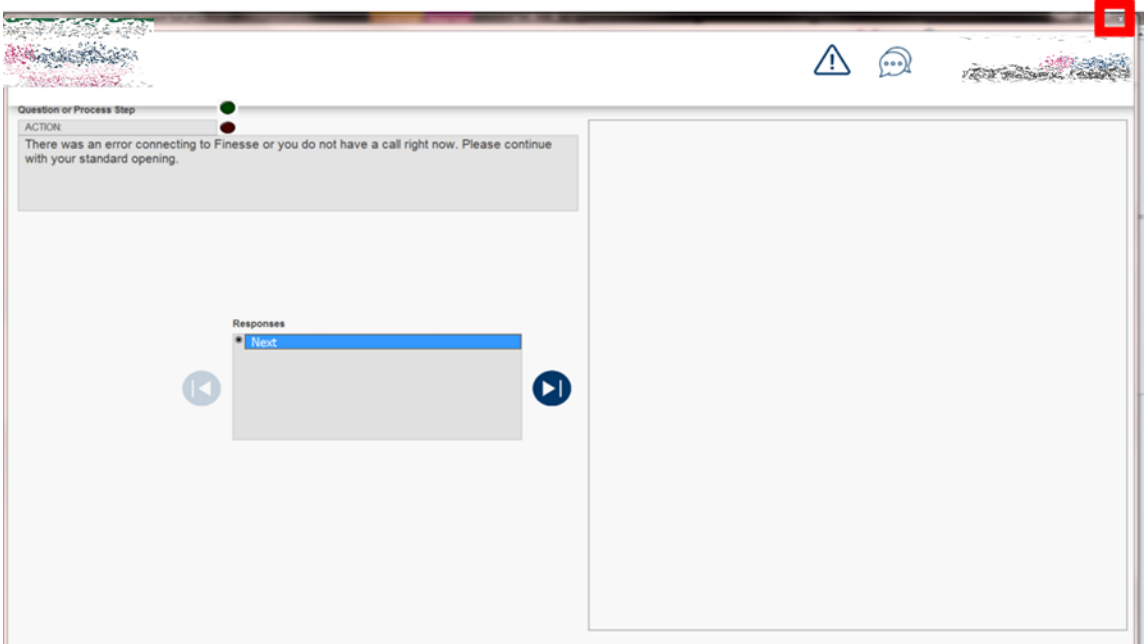

Figure 28: Exit System

3.4 Developer Graphical User Interface

This section provides a general understanding of the buttons, alerts and images and other features made accessible by the graphical user interface.

3.4.1 Toolbar

The tool bar at the top of the excel file will allows the developer to access enhanced features without needing to memorize shortcuts and hotkeys.

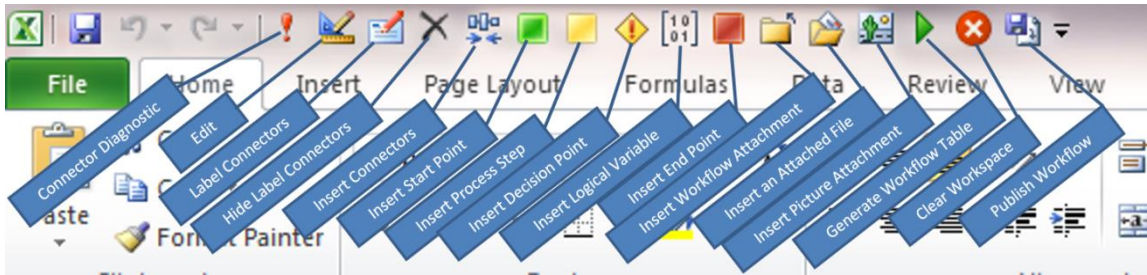

Figure 29: Toolbar

3.4.2 Edit Dialog Box

To edit dialog in a decision, start, process, or end box, the developer can click on the box they desire to edit and press “Ctrl” and “E” on their keyboard. This will bring up the form to edit any information about the box. To save an edit, the developer clicks the submit edit button on the editing form. To cancel an edit, the developer can either click on the cancel button or the exit button on the bottom right and top right of the editing form respectively.

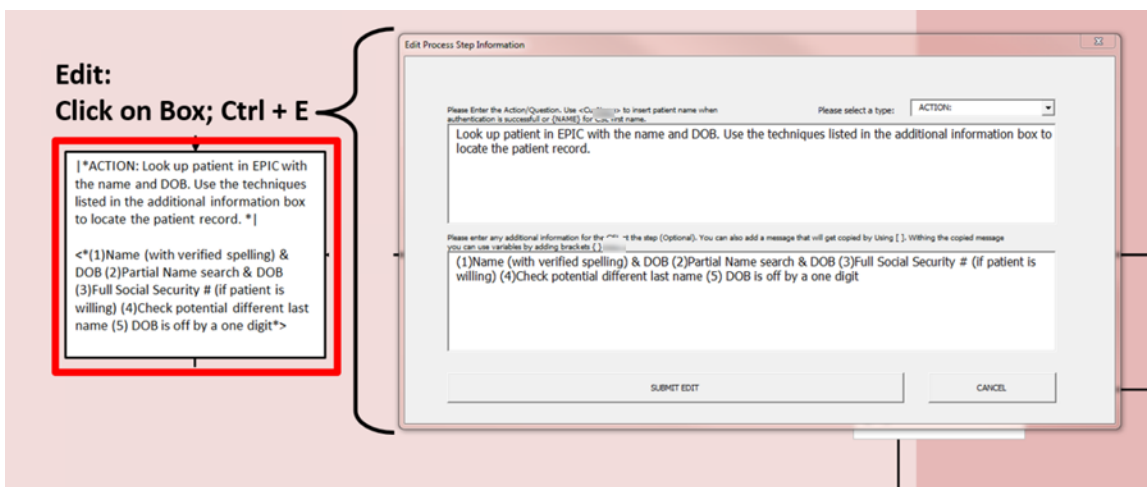

Figure 30: Editing Dialog Boxes

3.4.3 Toolbar Editing

Another way for a developer to edit a dialog box is to click a shape or connector and then click on the edit button located in the tool box as depicted in the picture below.

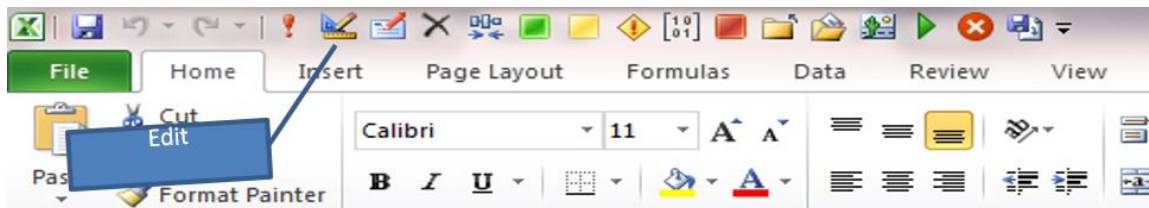

Figure 31: Toolbar Editing

3.4.4 Back End to Front End Workflow Translation

There is a complex relationship between the developer's interface, the table that the workflow is translated into and the user's interface. The figure below represents the relationships between these decision support tool features. The blue square on the right of this figure shows the back side of the program. There are two parts of the back end: the logic table and the logic design. The developer's interface mainly consists of the logic design sheet. They use this sheet to map out the workflow. When the developer maps and publishes the workflow, the Excel VBA code will analyze your workflow and create the Logic Table based on the developer's inputs. The figure below depicts how in the logic design, the box acts as the question and the lines leading away from the box act as the answers to those questions. The questions and the answers are recorded in the logic table and are also displayed in the front-end GUI. The Logic Design sheet allows the user to develop a workflow without needing to know the intricacies of how the logic table works. When the GUI is running, it will copy the logic table from the correct workflow; paste it

into its own logic table to read from. The GUI copies and pastes the workflow instead of reading directly from the original workflow to reduce the number of times the workflow GUI refreshes the workflow. Each refresh taxes the server and reducing the refresh rate reduces the effect on server latency. Since the GUI copies the logic table each time it initializes, the developer can publish a workflow at any time. This will enable real time updates to a workflow.

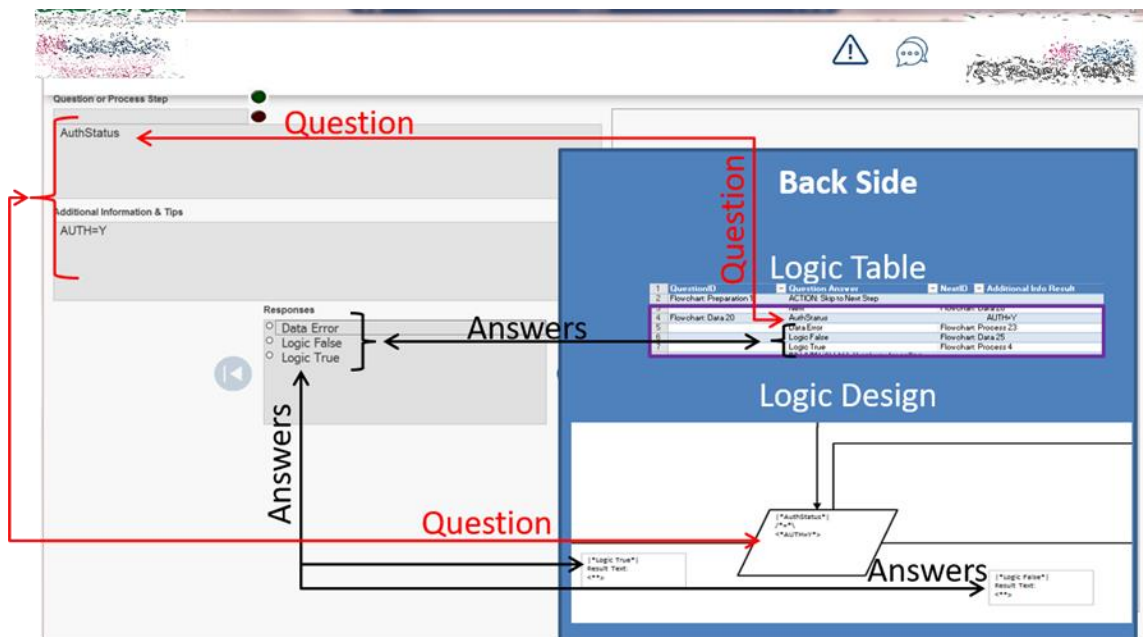

Figure 32: Relationship between the Developer Logic Design, the Logic Table and the User Interface

3.4.5 Adding Modules to Workflow

To add in connector, start, process, decision, end, logic variable, the next workflow to follow, attach a file or insert a picture to a step, the developer uses the tool bar and fills in the information for the added box, or clicks on an existing box and press Ctrl + C (Copy) then Ctrl + V (Paste) on their keyboard. Copying and pasting a step duplicates it. To edit

this step, the developer clicks on the pasted step and presses Ctrl + E on their keyboard. This opens the edit dialog form mentioned earlier in this passage. Additionally, only one start step can exist in a single workflow. The copying and pasting feature does not apply to the start step. If a developer attempts to add a second start step, they will not be able to save the logic design into a logic table or publish the table.

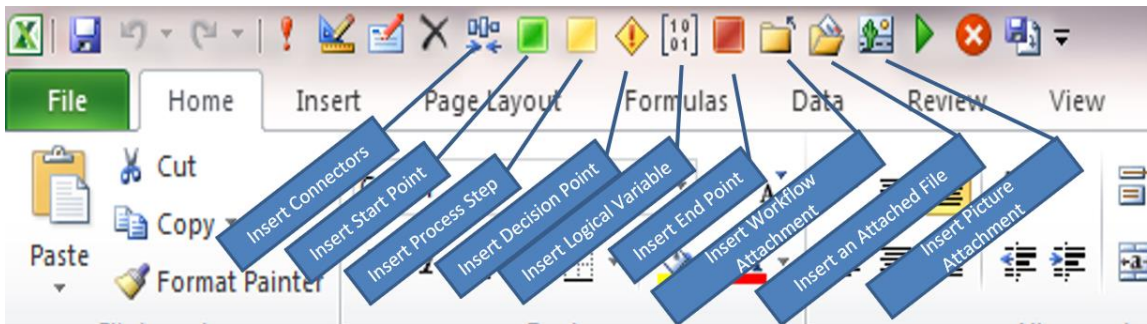

Figure 33: Adding Modules to the Workflow

3.4.6 Verbalize or Do Not Verbalize

For a decision point, a developer can either script the response for the CSR to say using “CALLER QUESTION:” or they can have it be something the CSR determines silently by choosing “DO NOT VERBALIZE:” In a process step, it will say “INFORM CALLER:” instead of “CALLER QUESTION:” and “ACTION:” instead of “DO NOT VERBALIZE:” but they effectively do the same thing. The difference between “INFORM CALLER:” and “DO NOT VERBALIZE:” on the front end is shown below. In the “INFORM CALLER:” the text will show as magenta and will indicate to the CSR to verbalize the text to the caller.

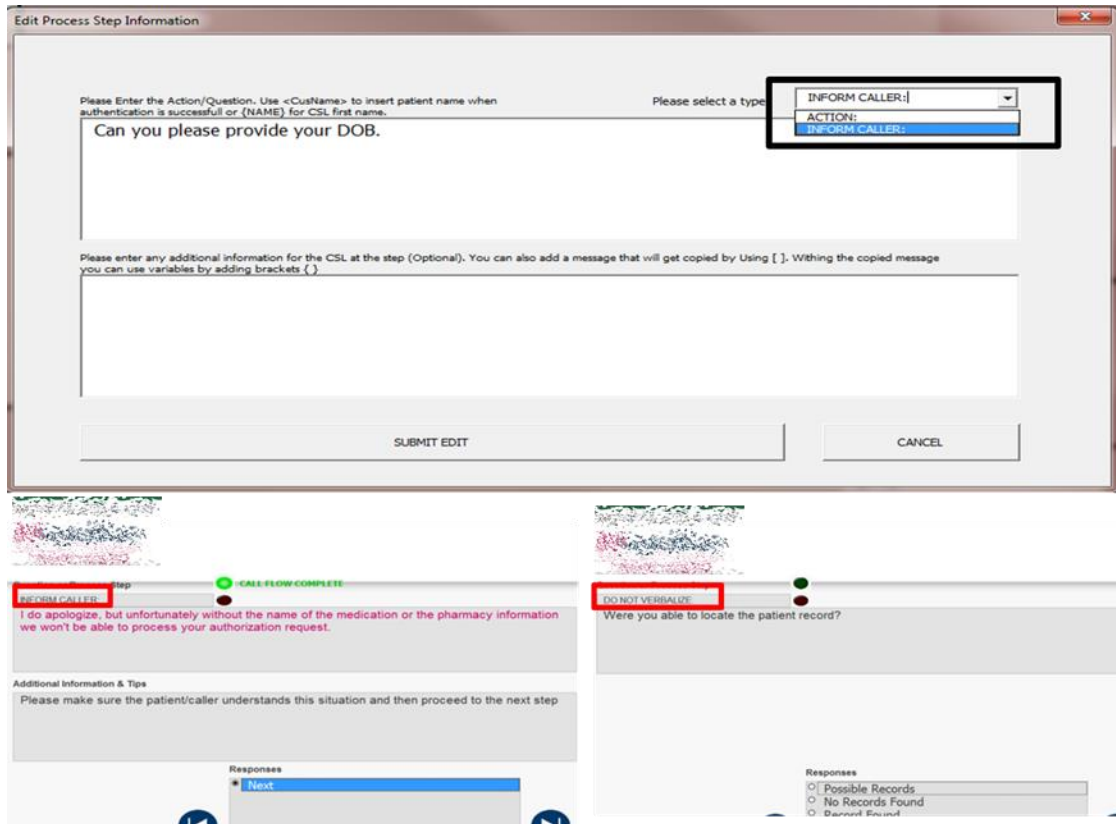

Figure 34: Process Step- Editing Dialog Boxes: Inform Caller and Do Not Verbalize

3.4.7 Process Step: Action/Question Input

In the Action/Question box, a developer inserts the information for the CSR to analyze/ask.

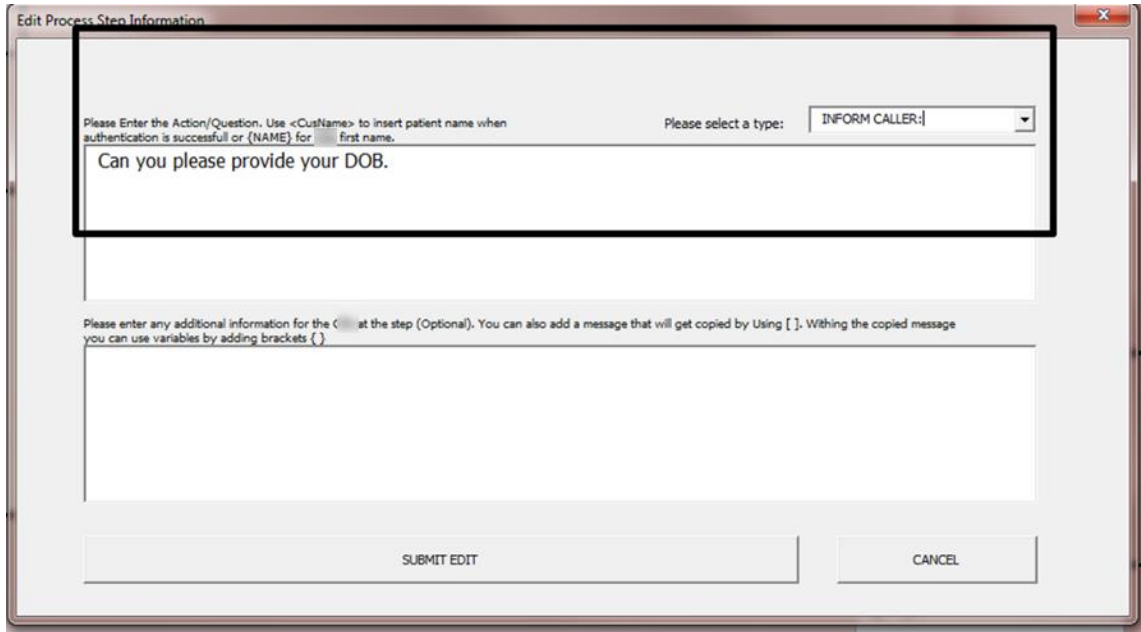

Figure 35: Process Step- Action/Question Input

3.4.8 Process Step: Additional Information Box

In the Additional Information Box, the developer inserts any additional information the CSR may need to know to determine the answer to the question.

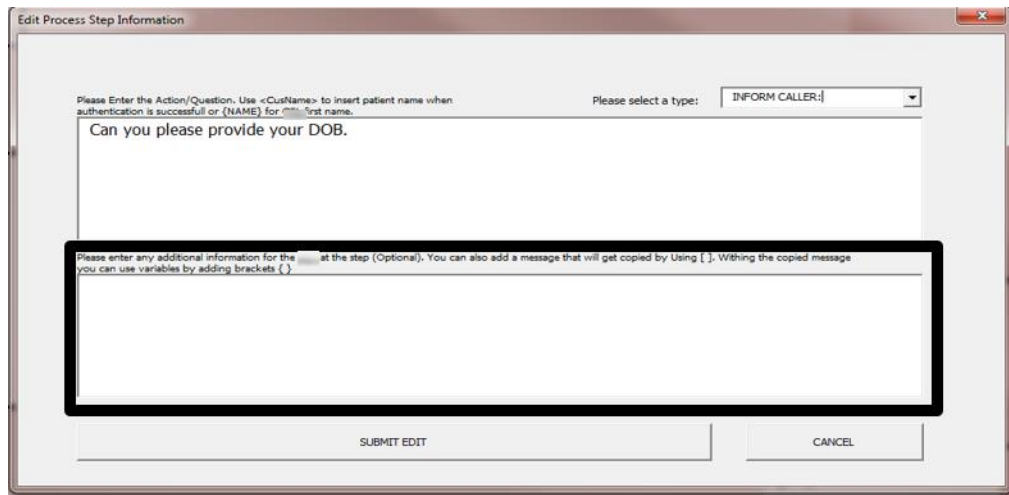

Figure 36: Process Step- Additional Information Box

3.4.9 Start Module

To start a workflow, the developer clicks the add start module button located in the tool bar to create a module. The developer can utilize the start step as a process step, if they can choose to use another module. If they choose to use another module such as a decide module at the beginning of the workflow, the developer can use the skip to next feature. Using the skip to next feature, the GUI will pass the start module and start with the second module in the workflow sequence. To engage this feature, the developer can check the “Skip Start Step” box bear the Submit Edit button. Otherwise, the start step can be used as a process step.

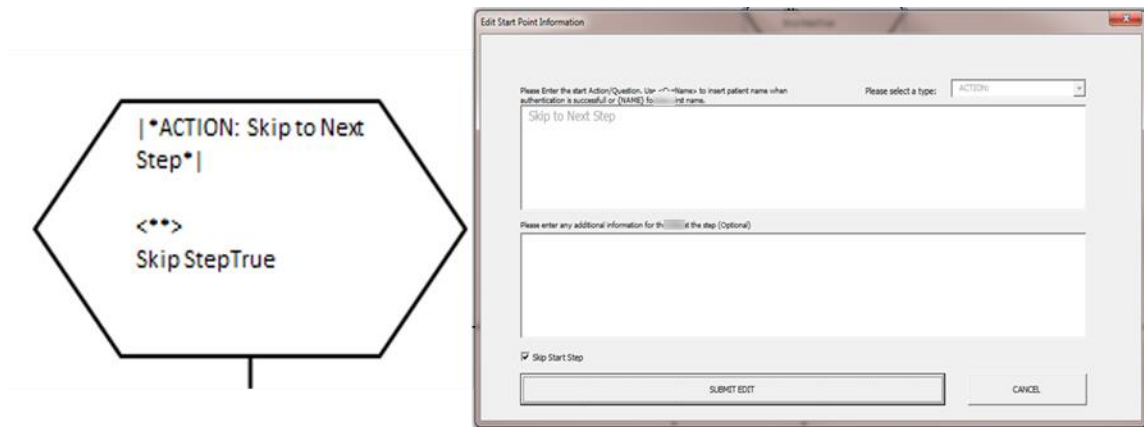

Figure 37: Start Module

3.4.10 Decision Module

When there are multiple paths that a workflow can take, and those paths are dependent on the situation, a decide module should be used. In the decide module, the situational question splits the workflow into the possible answers will be represented by the proceeding connectors.

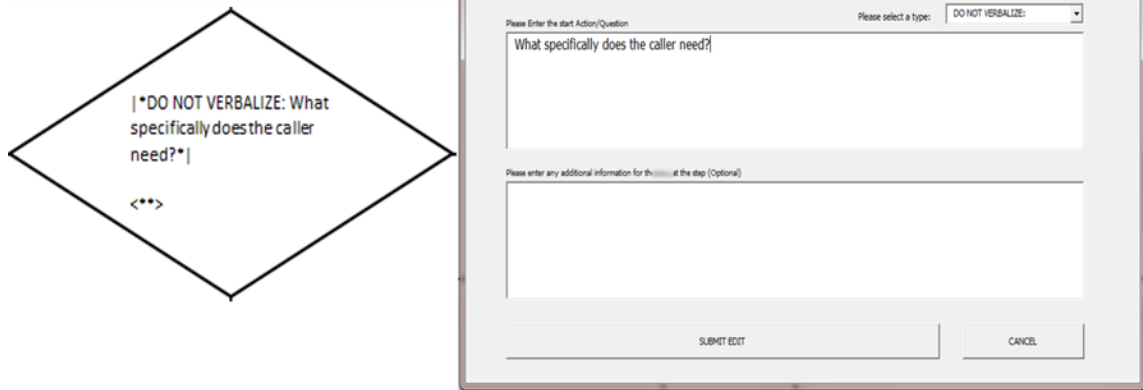

Figure 38: Decision Module

3.4.11 Solid Connectors

Solid connectors have multiple purposes. They can either connect a process to the next step, or they can contain the possible answers that correlate to a decide module. In the figure shown below, the connectors hold the possible answers to the question asked in the decide module.

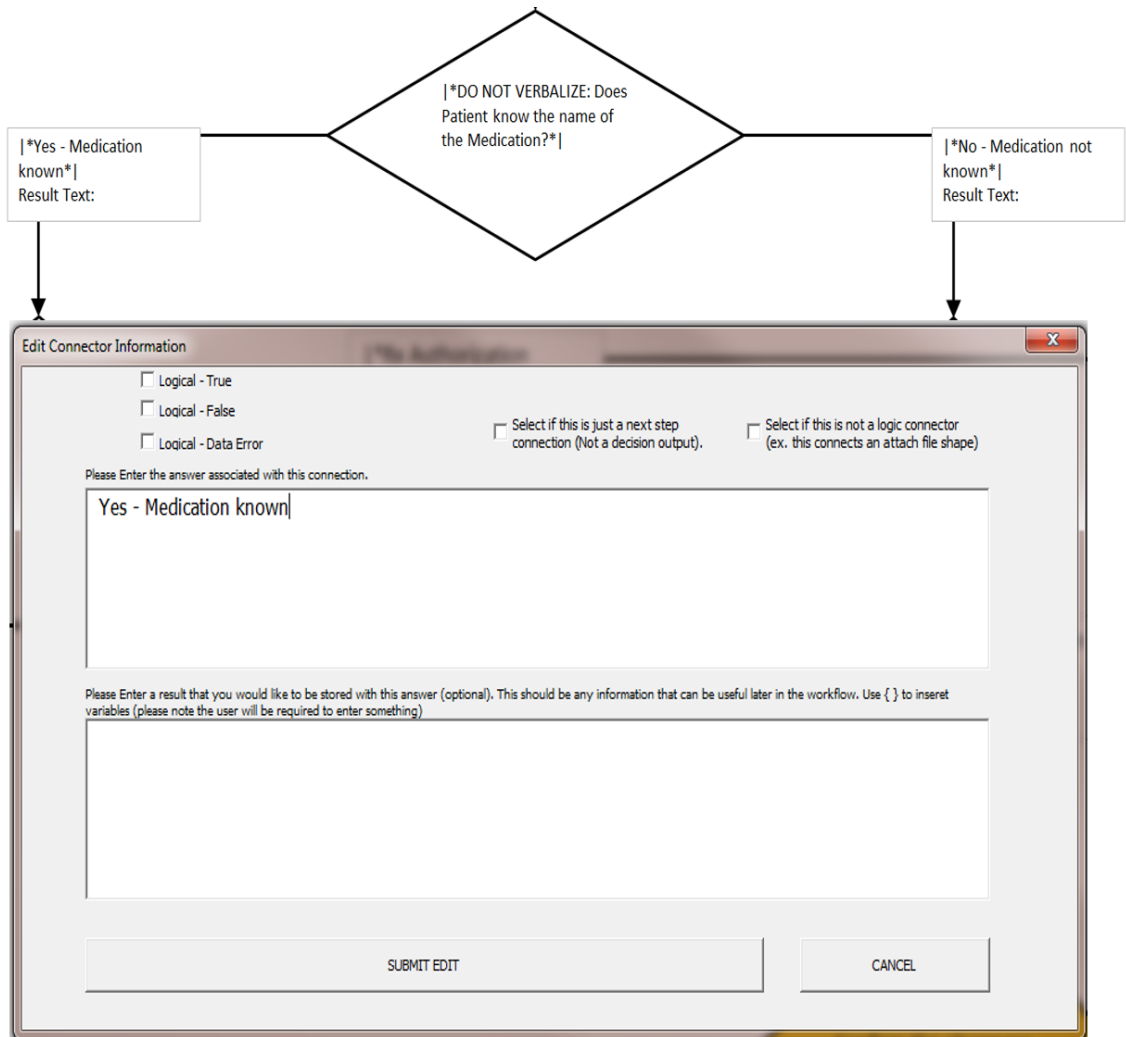

Figure 39: Solid Connectors

3.4.12 Process Modules

The process module is used to prompt the CSR to complete a process. It can either be in the form of an action or it can prompt them to inform the caller. In the picture below, additional information is added in. {Enter the medication name provided by the caller} is a variable that the CSR will be prompted to enter. Once they enter the variable, it will be input into the additional information sentence where they can copy and paste the message later.

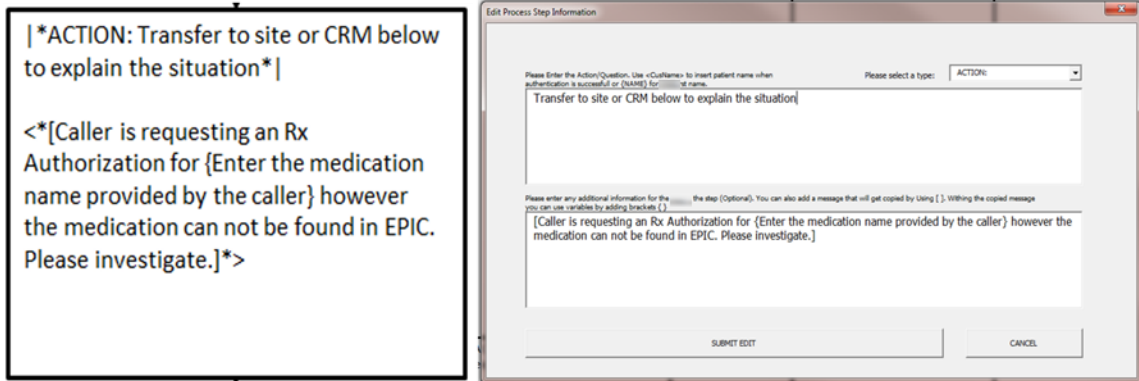

Figure 40: Process Module

3.4.13 End Module

The end module shows the end of a workflow. This will not bring the CSR through a different workflow, it will prompt them to end the call and complete any other off the phone work necessary. When a CSR reaches an end module within the workflow, the end of workflow timestamp is logged in the decision support database.

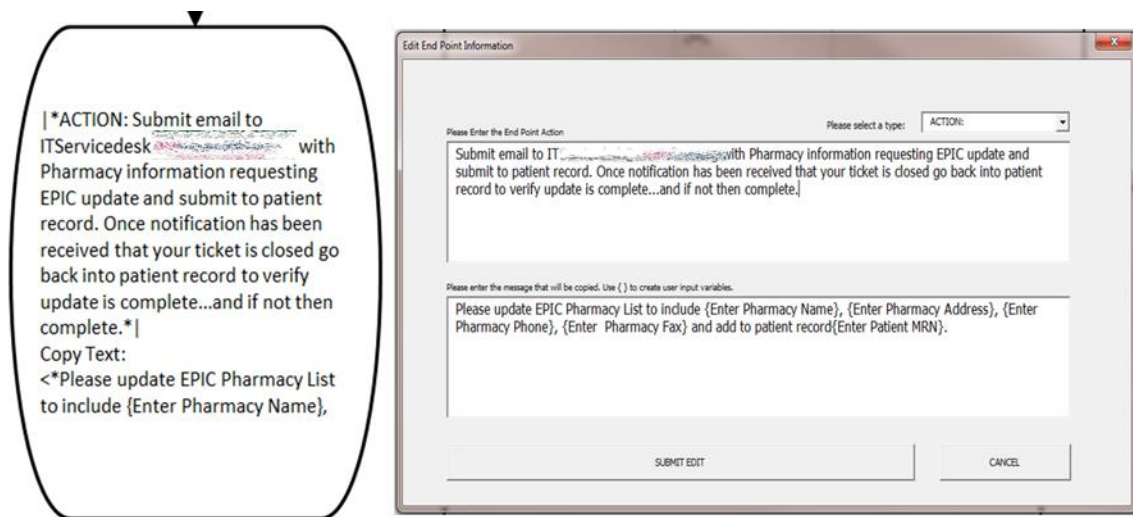

Figure 41: End Module

3.4.14 Change Workflow Module

The Change Workflow Module enables the developer to connect a different workflow from the current workflow. In the example below, the current workflow is being attached to the closing workflow. To attach it, click the ATTACH button on the right side of the edit form and attach the correct file.

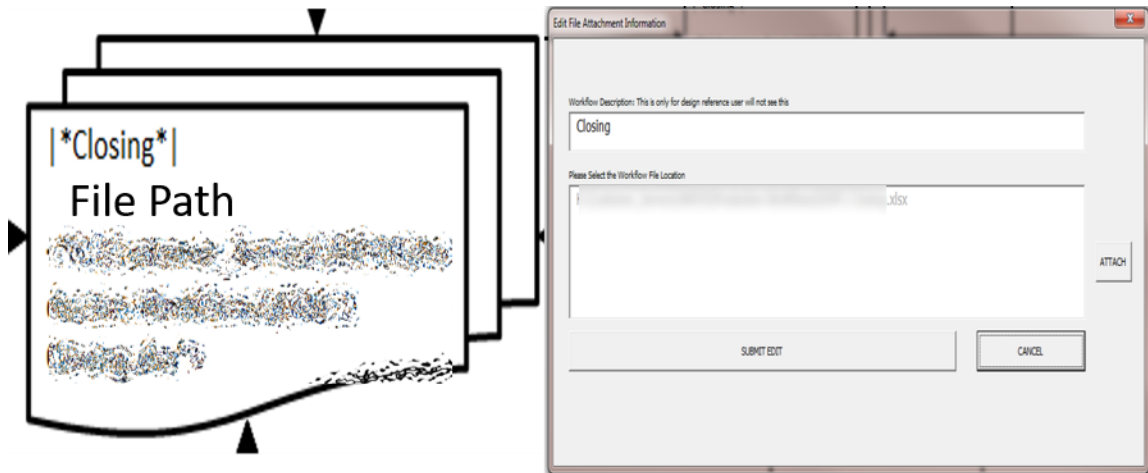

Figure 42: Change Workflow Module

Chapter 4: Case Study

Contact centers help patients navigate the dynamic and increasingly complex Healthcare landscape. In many cases, even if Healthcare systems invest in self-service infrastructure, not all patients will have the technological knowledge, or the luxuries required to access the self-service features. Contact centers reduce the administrative workload of nurses, physicians, and other medically trained personnel. Contact centers often schedule appointments and handle administrative tasks like supplying patients with directions to medical delivery sites or sending CRMs to physicians regarding prescription renewals.

The following case study applies a modified version of Sedgley's 5 phase framework described in the previous chapter. Sedgley's framework phases are as follows: Define, Map, Standardize, Design, and Evaluate. The framework is applied to a semi-centralized contact center servicing a Healthcare system in the Greater New York City Metropolitan Region. This contact center has three main lines of business. The first main line of business is the Primary Care line of business which is completely centralized. The second main line of business is the Specialty departments. There are ten sub lines of business within Specialty. Each specialty group is staffed by different CSRs. Although, some CSRs are skilled to, and often straddle multiple lines of business. The final major line of business handles all Billing related inquiries from patients. The objective of this study is to determine the return on investment from utilizing a decision support tool to collapse lines of business and achieve a universal liaison.

4.1 Phase One: Define

The first phase outlined in Sedgley's work is the definition phase. This phase aims to enable a deep understanding of stakeholder needs and requirements, outline necessary deliverables and plan accordingly.

4.1.1 Research Field

This case study focuses on a semi-centralized contact center servicing a Healthcare system in the Greater New York City Metropolitan Region. The three main lines of business that this contact center services are Primary Care, Specialty Care, and Billing. The specific scope of this study is constrained to include the Primary Care line of business and all sub lines of business within Specialty Care Services except for Dental. The Dental sub line of business and the Billing line of business were considered out of scope for this case study because in order to be skilled to these queues, the CSR must have a working understanding of separate computer software systems.

The Primary Care line of business is staffed by 72 CSRs during the time of study. Also, the Specialty department, excluding Dental, was staffed by 104 CSRs. The Specialty Department, excluding Dental, is broken up into nine lines of business. They include the Cardiology Department which was staffed by 10 CSRs, the Department of Medicine which was staffed by 28 CSRs, the Otorhinolaryngology Department which was staffed by 10 CSRs, the Neurology and Pain Department staffed with four CSRs, the Ophthalmology department staffed with 10 CSRs, the Urology department staffed with 10 CSRs, the Transplant department staffed with four CSRs, the Radiology department staffed with 20 CSRs, and the Pediatrics department staffed with eight CSRs during the Period of study.

In both the Specialty and Primary Care lines of business, CSRs take calls and some CSRs perform administrative or supplemental tasks during traditionally low call volume timeframes. Some administrative activities include managing the bump list. The bump list is a list of patient appointments that need to be rescheduled due to an unforeseen physician circumstance. One example is when a physician needs to cancel appointments to take personal vacation or if the physician is out on medical absence. In these cases, CSRs will receive a list of patients that need their appointments rescheduled at a later date. The CSR will perform an outbound call to each patient on the bump list and reschedule at the patient's earliest convenience. While the CSR is managing the bump list, they remove themselves from available idle within the Cisco telephony system and use an idle designated for bump list work. This prevents the CSR from receiving an inbound patient inquiry while managing the list. It also denotes that the CSR was in an unavailable state during this timeframe within the Cisco agent detail dataset. This available data is important when calculating the total number of agents that are available on average within a specific time period.

When an agent is available, the patient calling is routed directly to the available agent. If no agents are available to tend to the queue when the patient leaves the IVR system, assuming the patient does not abandon the call, the patient waits in the queue until a CSR is available, then the patient is routed to the CSR. The 176 CSRs in the Primary Care and Specialty Care departments attend to 104 queues that a patient could be placed into after exiting the IVR system. If each CSR was skilled enough to attend to all 104 IVR queues, substantial efficiencies could be gained through economies of scale.

4.1.2 Research Goals

The studied contact center is continually growing as the Health System. With the constant expanding of the Healthcare system and acquisition of sites, more sites are serviced by the contact center than ever before. In a growing contact center with constrained resources, universal liaisons realized through decision support systems can mean more efficient working habits can mean a sustained staff while still meeting the growing needs of the population. This research aims at estimating the value, feasibility, and sensitivity of this solution.

This research aims at understanding and mapping current contact center workflows, standardizing these workflows and designing more user-friendly future state processes for CSRs to follow and finally evaluating the possible future state of the contact center. To determine the value, feasibility, and sensitivity of the decision support solution, the current and future stated of the contact center were simulated. After verification and validation of the simulation models, a sensitivity analysis performed on these models helped determine relationships and thresholds for returns on investments.

4.1.3 Identifying Major Call Flows and Processes

One of the important steps in phase one of the five phase methodology is defining the scope of the project. Due to time constraints only one line of business, Department of Medicine was considered. While defining and developing workflows, a major scenario type-based method was deployed. Each major scenario type of workflow was identified and developed using the 5-phase methodology. The major scenario type identification

allowed segmentation of work and as new features were deployed to the decision support tool, the future state, which would allow a CSR to take any call from all lines of business, was considered. For example, in the Department of Medicine, most processes can be grouped into the following scenario types: prescription related processes, site related activities, call introduction process and appointment related assistance questions. Prescription related processes include prescription authentication, renewal processes and other prescription related processes. The site related activities include lab requisition forms, parking information and other site related processes. The call introduction process was developed to take the CSR through the process of determining if the patient authenticated and what their needs are based on IVR variables. Appointment related assistance includes appointment confirmation, telling the patient what they should bring to an appointment, referral related workflows, and other appointment-based questions a patient may inquire about. Additionally, the decision support tool was developed only for non-scheduling activities. The aforementioned Epic Decision Tree-Based Questionnaire tool was developed and deployed for the Department of Medicine, so specific scheduling activities were not developed in the decision support tool. The scheduling activities outlined in the decision support tool guide the CSR through the general process of using the Epic tool to schedule an appointment.

Individual processes were identified through observation and discussing patient inquiries with CSRs, and other subject matter experts. Each major scenario type was identifying first, then the scenarios were broken into sub scenarios. Finally, the sub scenarios were broken into root scenarios. The following table shows the scenarios, sub scenarios and the root scenarios for identified for the Department of Medicine. Note: Root

Scenarios are written from the patient perspective, Med is short for Medicine, pharm is short for Pharmacy, Rx is short for prescription, and Dr. Is short for Doctor.

Table 6: Major, Sub, and Root Scenario Identification Table

Scenario	Sub Scenario	Root Scenario
Prescription (Rx) Related	Rx Refill	Multiple Pharmacies (One Med Here, One Med There)
Prescription (Rx) Related	Rx Refill	Send Meds to Same Pharmacy
Prescription (Rx) Related	Rx Refill	Reconcile Medication Refill Dates
Prescription (Rx) Related	Rx Refill	Change Pharmacy at next Refill
Prescription (Rx) Related	Rx Refill	Dr. Sent Med to Wrong Pharm
Prescription (Rx) Related	Rx Refill	Went to Pharm, med not there
Prescription (Rx) Related	Rx Refill	Medicines Prescribed under Different Doctors
Prescription (Rx) Related	Rx Refill	Refill, but change Dosage
Prescription (Rx) Related	Rx Authorization	Rx Authorization
Prescription (Rx) Related	Question about Medication	Symptoms/Reactions
Prescription (Rx) Related	Question about Medication	Wants to change dosage
Prescription (Rx) Related	Question about Medication	Dosage Confusion
Prescription (Rx) Related	Question about Medication	Past Rx
Prescription (Rx) Related	Question about Medication	Advertised medication
Prescription (Rx) Related	Question about Medication	Newly prescribed medication
Prescription (Rx) Related	Question about Medication	Wants a new medication
Prescription (Rx) Related	Question about Medication	Side effects
Prescription (Rx) Related	Question about Medication	Medication directions
Prescription (Rx) Related	Question about Medication	Other

Prescription (Rx) Related	Question about Medication	Incorrect quantity/dosage on Rx
Prescription (Rx) Related	Pharmacy Update	Prescription Pharmacy Update
Prescription (Rx) Related	Pharmacy Update	Demographic Pharmacy Update
Prescription (Rx) Related	Incorrect quantity/dosage on Rx	Incorrect quantity/dosage on Rx
Prescription (Rx) Related	Alternates	Insurance Related
Prescription (Rx) Related	Alternates	Not Covered/Too Expensive
Prescription (Rx) Related	Alternates	Symptoms/Reactions
Prescription (Rx) Related	Alternates	Doctor prescribed med, but too expensive, request generic
Prescription (Rx) Related	Alternates	Asking Questions about Generic Options
Prescription (Rx) Related	Wants a new medication	Wants a new medication
Scheduling / Appointment	New Patient Forms	Fill out new patient forms online
Scheduling / Appointment	Location Update	Want to Switch Locations (Dr. @ multiple locations)
Scheduling / Appointment	Reschedule appointment	Reschedule appointment
Scheduling / Appointment	Cancel/Confirm	Cancel
Scheduling / Appointment	Cancel/Confirm	Confirm
Scheduling / Appointment	Patient late for appointment	Patient late for appointment
Scheduling / Appointment	Schedule appointment	Schedule appointment
Scheduling / Appointment	Schedule appointment	Next available appointment
Scheduling / Appointment	Schedule appointment	Travel Shots
Scheduling / Appointment	Visit Information	Directions / Address
Scheduling / Appointment	Visit Information	What to bring to appointment/Prep questions (do I need to fast, etc.)/Allergies (no antihistamines), Arrive 15 minutes before, etc.
Scheduling / Appointment	Visit Information	Which Dr. am I seeing

Scheduling / Appointment	Visit Information	Who is covering Dr. if Dr. left practice
Scheduling / Appointment	Visit Information	Duration of appointment
Scheduling / Appointment	Referrals	NPI
Scheduling / Appointment	Referrals	Referral Expiration
Scheduling / Appointment	Referrals	Does patient need referral
Scheduling / Appointment	Referrals	If diagnosis is incorrect, what is the process
Scheduling / Appointment	Referrals	Patient wants to see Dr. X, but the referral says Dr. Y
Scheduling / Appointment	Referrals	Wanting to change established Dr.
General / Administrative / Site Info		DME / Supplies
General / Administrative / Site Info	Med Record	Medical Records Request
General / Administrative / Site Info	Lab Related	Lab Requisition Forms
General / Administrative / Site Info	Lab Related	Getting Lab Forms
General / Administrative / Site Info	Lab Related	Lab Results Request
General / Administrative / Site Info	Visit Information	Directions
General / Administrative / Site Info	Visit Information	Parking information
General / Administrative / Site Info	Visit Information	Patient asking for Provider info
General / Administrative / Site Info	Visit Information	Travel Shots
General / Administrative / Site Info	Visit Information	Wait Time or is appointment running on time
General / Administrative / Site Info	Billing	What Insurances do you take/not take
General / Administrative / Site Info	Billing	Insurance (Scheduled with a fellow, need to know who the head Dr. is for insurance)
General / Administrative / Site Info	Billing	Co-payment cost
General / Administrative / Site Info	Billing	Self-Pay patient cost

After identifying the major, sub and root scenarios, these scenarios were mapped in phase two of the five phase methodology.

4.2 Phase Two: Map

Phase two in Sedgley's publication is the mapping phase. This phase involves observation of current processes, mapping of the processes and validation discussions with subject matter experts.

4.2.1 Process Mapping Overview

In the mapping phase, workflows within the Primary Care and Specialty Care lines of business were observed, discussed with CSRs who were subject matter experts, and vetted with operational supervisors and management staff. To reduce the project scope due to timeline concerns, workflows from only one line of business were defined, mapped, and vetted. However, following this mapping process, all remaining lines of business can be observed, discussed about, mapped and vetted. Additionally, only non-scheduling workflows were considered because in the studied contact center, decision support using the Epic questionnaire powered by decision tree logic was being developed and used across the specialty lines of business. Epic's integration and automation with patient history make it a better tool for scheduling purposes. However, due to Epic system limitations on the number of instances that can be simultaneously opened, non-scheduling workflows cannot be practically handled within the Epic decision tree logic. An external decision support system was developed, and workflows were transcribed into this application. The following describes the mapping of three processes and identifies areas for improvement that were later addressed.

4.2.2 Call Opening

Every call that arrives at the studied contact center goes through a standard opening. Every patient that calls is required to authenticate before a CSR can help the patient with the inquiry. This is because in the Healthcare space, patient privacy and confidentiality are required by HIPAA. In some cases, the patient is able to fully authenticate within the automated IVR self-service platform. If the patient fully authenticates, the CSR needs to confirm that they are speaking with the correct patient. If the patient does not authenticate or partially authenticates, the CSR needs to finish the authentication process. Through observation, it was determined that in most cases, a patient wants to describe their inquiry before completing authentication. This is allowable if the CSR listens to the patient's inquiry then fully authenticates the patient before proceeding to resolve the patient's inquiry. Additionally, the IVR system passes its variables to the Cisco Finesse system. In the current system, to gain context around the patient's activities within the IVR, the CSR must open the Cisco Finesse Screen, and review each variable. This is a cognitively demanding process, and, in some cases, the CSRs skip this interaction and directly ask the patient how they can help them. While ignoring the Finesse screen is a solution dealing with the complicated variables, it is not the best solution. Although a rare occasion, some patients show resentment for going through the IVR system only to have a CSR ask them what they need help with. This complicated conundrum is addressed in the design phase of the case study. After authenticating and determining the general need of the patient, and CSR will exit the opening process and meet the specific needs of the patient.

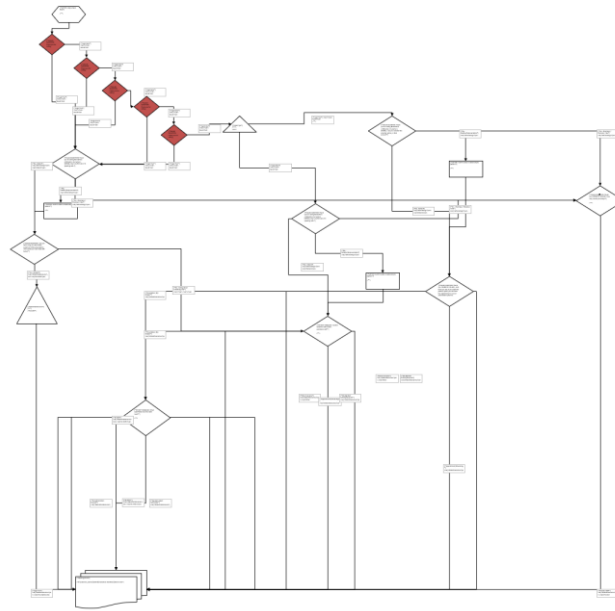

Figure 43: Baseline Call Opening: Manual IVR Contextualization

4.2.3 Prescription Renewal

The following workflow describes the proper way to solve the patient’s inquiry when they state that they arrived at the pharmacy, and the pharmacists stated the patient’s medications did not come through the computer system. First, the CSR should open the patient’s prescription orders and attempt to find any recent and relevant records. If no recent and relevant records are found, the CSR sends a CRM to the prescribing physician to remind them to send the request to the pharmacy. To accurately send the CRM to the correct physician, the CSR must consult the guidelines or memorize the CRM routing pools based on scenario, physician, and line of business. This is a cognitively demanding task and is addressed in the design phase. If a request is located, the CSR should inform the patient that a refill request has been sent and inform them of any prescription related information. The CSR then advises the patient to call the pharmacy before going again. If

the patient claims to have already called the pharmacy, the CSR escalates the call by transferring the patient to the secretary at the prescribing physician site.

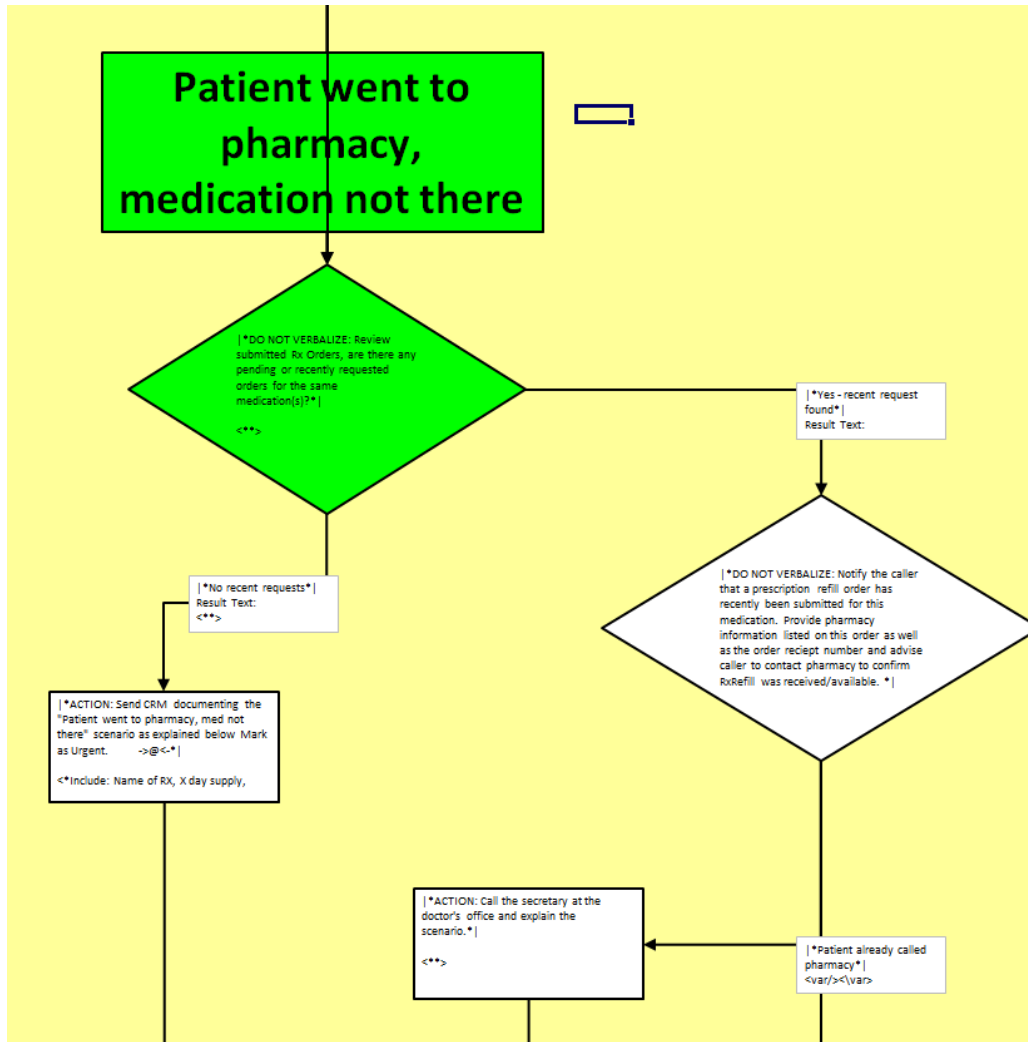

Figure 44: Patient Went to Pharmacy, Medication Not There

4.2.4 Patient Inquiring about Appointment Preparation

When a patient inquires about preparing for an upcoming appointment, the CSR will curate their response based on the specific scenario or general appointment type. The

workflow outlined in the figure below describes the proper response for four different appointment scenarios. If a patient is new, they should arrive to their appointment 30 minutes early allowing time to fill out new patient forms, they are also required to bring a form of photo identification, their insurance card, their referral, and any co-payment if it is applicable. When a patient inquires about preparing for an allergy testing appointment, the proper response is to alert the patient to discontinue antihistamines for two days prior to the appointment date. When a patient inquiry about preparing for an Endocrinology appointment and they are a new patient that is diabetic, the proper response is to tell them to bring 3 days' worth of blood glucose level readings, so the physician can establish a baseline. Finally, when the patient calls inquiring about preparing for a pulmonary function test, they are reminded to avoid consuming caffeinated products for the day of the exam and discontinue inhaler spray for four hours prior to the exam. Clearly, some appointment types were not defined in the appointment preparation workflow. In the design portion of the methodology, this concern was addressed by adding feedback functionality to the decision support tool.

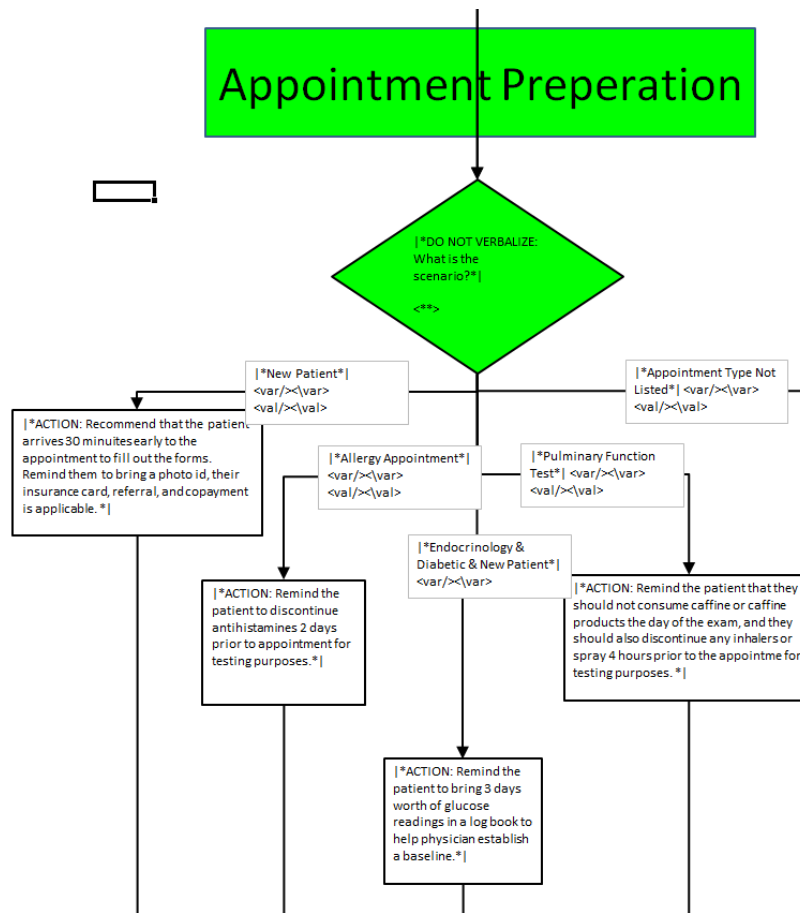

Figure 45: Appointment Preparation Workflow

4.3 Phase Three: Workflow Standardization

Phase three in Sedgley’s methodology is the standardization phase. Most scenarios were identified and standardized within the PDF guidelines, after confirming validity these flows were considered standardize. However, one major area of improvement identified in the standardization phase is scenario and physician-based CRM routing.

4.3.1 Development of Standardized CRM Routing Database

In healthcare contact centers, informational flow between patients to clinicians through the CSRs is an important process to consider. There are three main communication

types that the studied contact center handles. The first is prescription renewals. The next is appointment scheduling. The last is Customer Relationship Messaging. All lines of business use these forms of communication to transfer information between patients and clinicians. These communication types enable important business processes that rely on communication patient inquiries. Considering clinical messaging, CRM routing is incredibly complex. Standardization is one way to reduce the complexities observed in the CRM routing processes.

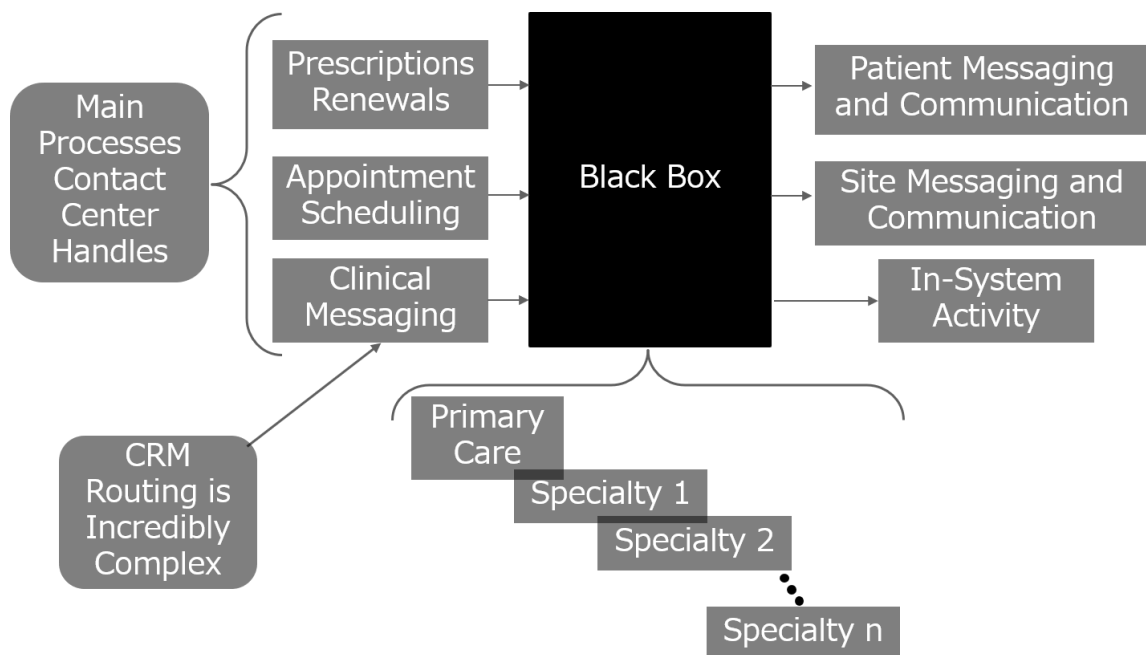

Figure 46: Information Flow from Patients through CSRs to Clinicians

In the healthcare contact center environment, Customer Relationship Messages (CRMs) are an important way to keep in contact with doctors and transfer important medical information in a timely fashion without reducing the doctor’s efficiency to perform clinical work. Singh and Diwas note that when physicians multitask, they show significant negative impacts on care. Thus, directly contacting the physician to answer a patient’s

inquiry while the physician is attending to another patient is not recommended. If this process is performed, the physician could have a defect in care of the current patient, and this could lead to rework later on. Additionally, this would lead to a high hold time with the CSR an increased utilization of the CSR and a longer wait time for the other patients calling the contact center while the CSR waits for the physician to answer the phone. Instead, using CRMs, a CSR can update send a message to a queue that the physician can handle later on after switching modalities. This process reduces physician errors but may lead to a lower first call resolution if physicians do not complete the requested transaction in a timely manner. In some cases, a physician may be on vacation or may leave the practice. In these instances, any CRMs routed to their pool should be rerouted to a covering physician's pool to answer the patient's inquiries in a timely manner. Another option is to create a CRM pool that is worked by a group of physicians and clinicians. Regardless, standardization of CRM pools along with reporting and tracking to ensure CRM's are responded to in a timely fashion is one way to communicate and execute healthcare delivery practices effectively. This CRM pool would be worked by physicians outside of appointment hours while they normally attend to administrative activities. This CRM pool could also be worked by nurses if the task or deliverable was within their scope of practice or by secretaries if the request was administrative based and not medically based.

To achieve proper CRM routing, standardization of CRM routing based on provider and scenario must first take place. In the studied contact center, to reduce the number of pools each provider must review, CRM scenarios were broken into three main categories: Prescription refill requests, clarifications on labs/non-urgent/abnormal imaging/appointment or referral dates and time, and forms that require a response. These

three categories were chosen while developing the decision support application for the first line of business. As the tool continues in development and more lines of business are added into the system, the scenarios are subject to modification, and additional scenarios may be added. The first main category, refill requests refers to any prescription refill requests a patient may have. This includes but is not limited to prescription renewal, prescription authentication that needs a physician's approval, refills where the patient is requesting a change of dosage, refills where the patient is requesting a different medication, refills where a patient is requesting a generic medication, insurance related inquiries concerning prescription refills, reconciliation of medication refill dates for patients with multiple medications or when patients arrive at a pharmacy and the pharmacist says the prescription was never sent by the doctor. This CRM pool will vary in urgency. It is important to include a flag or field for urgent response to ensure urgent CRMs are handled in a timely manner. The second main category is the clarifications on labs/non-urgent/abnormal imaging/appointment or referral dates and time category. This category is a general administrative category that is for non-urgent information. Finally, the third category is the forms which require a response. This category can include anything from referral information to lab results. All of these CRM's require a response to be considered resolved calls. Ideally, this pool will be cleared daily to boost first call resolution rate and increase customer satisfaction. These categories are subject to change and are subject to adding more scenarios as more lines of business are brought onto the decision support tool.

Customer Relationship Messages, or CRMs, are important for call documentation purposes and to transfer the patient's messages and inquiries to a physician, secretary, or a nurse who can better meet the requirements of the patient. When a CSR is universal, one

of the most cognitively demanding tasks will be memorizing which CRM routes to which CRM pool depending on the call's originating line of business, the patient's scenario or inquiry, the provider, and the line of business subgroup if applicable. A CSR will need a way to navigate and automatically script a CRM based on these criteria. One way to efficiently store this CRM routing information is to develop and maintain a CRM routing database which contains these criteria. A CRM routing database will assist a CSR to route a CRM to the correct physician or pool of medical professionals based on the patient's scenario and contact center's line of business. To organize and store the CRM scenario, provider, line of business with the correct CRM routing pool, the studied contact center developed a CRM routing database. Within the CRM routing database, there were 6 data tables. The first table was the line of business table. The line of business table contains three fields. The first field is the line of business identifier which was the primary and foreign key. The second field is the line of business field which displays the short-hand abbreviated line of business name. The final field within the line of business table contained the line of business full name which was the unabbreviated version of the line of business name.

LOB_tbl			
LOB ID	LOB	LOB_FullName	Click to Add
1		Department of Medicine	
2	Urology	Department of Urology	
3	MMP	Department of Pain	
4	Neurology	Department of Neurology	
5	Pediatrics	Department of Pediatrics	
6	Dental	Dental	
7	Risk & Claims	Risk and Claims	
8	CARE	Medical Group	
9	Radiology	Department of Radiology	
10	Ophthalmology	Department of Ophthalmology	
11	Otorhinolaryngology	Department of Otorhinolaryngology	
12	Cardiology	Department of Cardiology	
14	Transplant	Department of Transplant	
15	SBO	Billing	
*	(New)		

Figure 47: Line of Business Table

The second table within the CRM routing database is the provider table. This table contained six fields. The first field was the provider identifier. This is the primary key for the provider table. The second and third field for the provider table was the provider's first name and last name respectively. The fourth field for this table was the EPIC identifier. The EPIC identifier is the provider's unique identifier within the EPIC system. The fifth field was the name identifier. This is a calculated text field that displays the provider's last name, then a comma and a space, then the provider's first name followed by a space and the provider's EPIC identifier within brackets. The final field is a binary field that allows the table developer to toggle the physician between being an active physician or an inactive physician. Under each physician is a list of associated information that a developer can add. The associated information list consists of the LOB identifier, and the abbreviated LOB name, the subgroup name, the scenario, the CRM pool, and the contact type. These

additional associated fields either have been explained in a previous table or will be explained later in this chapter.

Provider ID	First Name	Last Name	EPIC ID	Name_ID	Active	ID	LOB ID	Subgroup ID	Scenario ID	Routing Recipients	RoutingType
18 A			6354654	[6354654]	<input type="checkbox"/>						
						27	Transplant			CRM Test Pool [12342]	CRM
						32	Transplant				
*						(New)					
*					<input type="checkbox"/>	(New)					

Figure 48: Provider Table

The queue table is the third table within the provider routing database. This table relates the name of a queue and the corresponding line of business. There are three fields within this table. The first field is the identifier. This is the primary key for this table. The next field is the queue name field. This is the name of the queue as found when parsed from the Cisco Finesse HTML. The third field in the table is the line of business field. This relates the queue name with the line of business.

ID	Queue Name	LOB_ID	Click to Add
1	C_SPEC_RADGEN_E_SG	Radiology	
2	C_SPEC_RADGEN_S_SG	Radiology	
3	C_SPEC_RADMAMO_E_SG	Radiology	
4	C_SPEC_RADMAM_S_SG	Radiology	
5	C_SPEC_RADNUC_S_SG	Radiology	
6	C_SPEC_TRANSP_S_SG	Transplant	
7	LIG_PROV_EMBL	Risk & Claims	
8	OTHR_MEMB_EMBL	Risk & Claims	
9	OTHR_PROV_OTHR	Risk & Claims	
10	CLMS_MEMB_EMBL	Risk & Claims	
11	CLMS_MEMB_OTHR	Risk & Claims	
12	ELIG_MEMB_EMBL	Risk & Claims	
13	OTHR_PROV_EMBL	Risk & Claims	
14	OTHR_PROV_OTHR	Risk & Claims	
15	TM-Main Menu		
16	MAP_PEDS		
17	MAP_SCHED_PEDS		
18	SCHED_BRXE_S_SG		
19	SCHED_CFCC_S		
20	SCHED_CHCC_E		
21	SCHED_CHCC_S		
22	SCHED_FCC_AM_E		
23	SCHED_GC_E		

Figure 49: Queue Table

The queue table serves a functional purpose within the decision support tool by reading the queue name from Cisco Finesse HTML, translating this queue name into a line of business, and auto populating the line of business within the GUI. When a CSR takes on a call, the Cisco Finesse system will create a screen pop using the computer's Internet Explorer internet browsing application. When the decision support tool application is initialized, the system looks through the opened Internet Explorer tabs. When the system finds a Cisco Finesse tab, it will parse the HTML within the tab, pull bits of information and assign them to variables within the instance of the application. One bit of information parsed from this HTML is the queue name. As the application opens, if a queue name exists within Cisco Finesse, then the queue variable within the application will be assigned to that queue name. Additionally, the queue name will be related to the LOB using this table. If

the queue name exists within the Cisco Finesse HTML, the queue name exists within the CRM routing database and the queue name has a corresponding line of business identifier within the CR database, the Line of Business will automatically be updated within the GUI. This ultimately reduces the amount of cognitive strain on the CSR and reduces the time to handle a call by a small margin for each call. However, in a high-volume contact center, shaving one second off of most calls can add up to a substantial return in the wait time for patients and the number of additional patients that can be addressed.

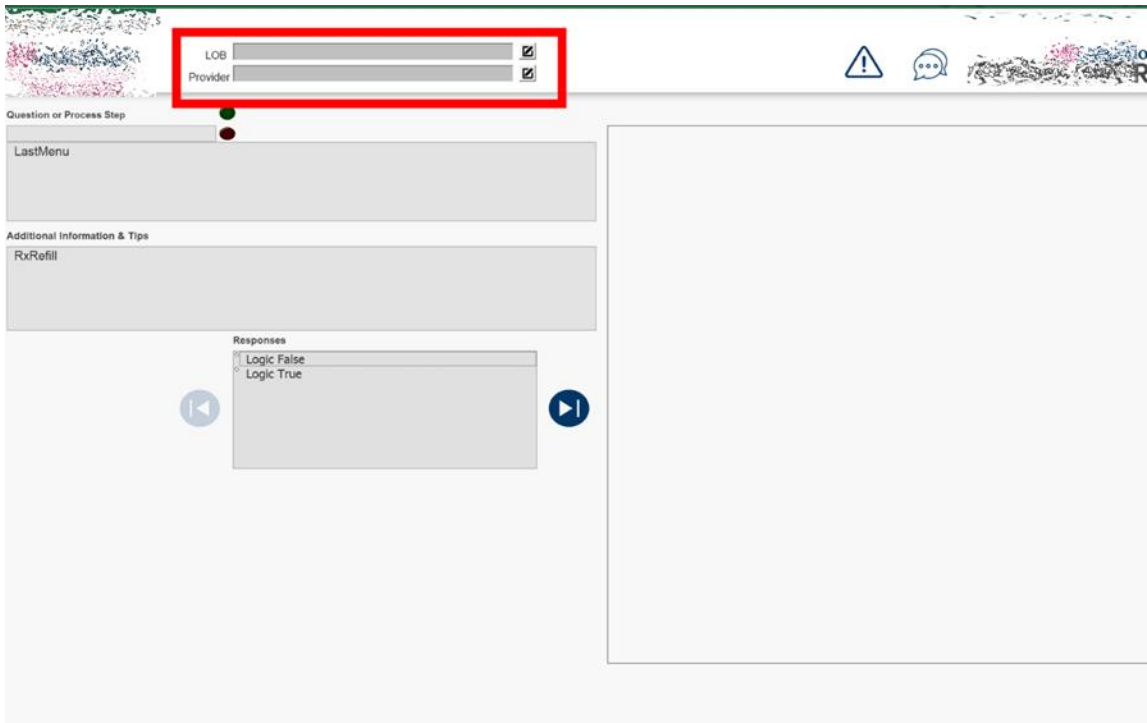

Figure 50: Line of Business and Provider GUI Auto-population

The fourth table within the CRM routing database is the routing map table. This table is the additional table within the provider table. This table consists of seven fields. The first field is the identifier field. The identifier field is the primary key for this table. The next field is the line of business identifier. This field describes the line of business. A

provider may serve multiple lines of business. For example, one provider may be a pediatric urologist. This provider may work for both the health system’s pediatrics department and urology department. The next field is the provider field. This field is a foreign key that allows for the additional drop-down table within the provider table. The next field is the subgroup identifier. This field allows for specification of a department within a line of business. For example, at the studied contact center, the department of medicine line of business consisted of ten subgroups of medicine. The next field is the scenario identifier field. This field allows for one provider to route CRMs by the scenarios listed within the scenario table. The next field is the routing recipients. This field describes the correct CRM pool for the scenario, provider, line of business, and subgroup combination. The final field is the routing type. This field describes if the CSR should send a CRM or if the CSR should call the provider depending on the scenario.

ID	LOB ID	Provider ID	Subgroup ID	Scenario ID	Routing Recipients	RoutingType	Click to Add
27	Transplant	[Redacted]			CRM Test Pool [12342]	CRM	
32	Transplant	[Redacted]			CRM Test Pool [12342]	CRM	

Figure 51: Routing Map Table

The fifth table in the CRM routing database is the scenario table. This table describes consists of a list of the general scenarios that would require a CRM to be sent to the physician or to a pool. There are two fields within this table. The first field is the identifier. This field is the scenario table’s primary key. The second field is the scenario field. This field outlines the scenario that could occur.

Scenario_tbl		
ID	Scenario	Click to Add
1	Rx Refill Request	
2	Clarifications on Labs, Non-Urgent/Non-Abnormal Imaging Appointments, Referral Dates, and Times	
3	Forms Which Require A Response	
*	(New)	

Figure 52: Scenario Table

The final table within the CRM routing database is the scenario table. This table describes the list of sub groups or sub lines of businesses. The first field is the subgroup identifier. This field is the table’s primary key. The second field is the subgroup name. This table relates to the routing map table. If the routing map table’s LOB identifier is a line of business with multiple subgroups within it, the subgroup must be chosen.

Subgroup_tbl		
Subgroup ID	Subgroup	Click to Add
5	Allergy	
2	Dermatology	
3	Endocrine	
7	Gastroenterology	
9	Geriatrics	
6	Infectious Disease	
1	Internal Medicine	
8	Nephrology	
4	Pulmonary	
10	Rheumatology	
*	(New)	

Figure 53: Subgroup Table

4.4 Phase Four: Automation in Decision Support Design

The Systematic Review Kawamoto, Houlihan, Balas, & Lobach performed in 2005 brought key insights about decision support facilitators in a healthcare environment. These

insights were the need for a computer-based decision support tool that automates processes, provides actionable outputs, and collects time stamped data. Before the development of the decision support tool, the studied contact center deployed PDF based guidelines. These guidelines meet two of these four criteria. They are computer based and provide actionable outputs if used correctly. The criterion that the decision support tool development additionally focused on was process automation and timestamp data collection. Theoretically, these four pillars would help facilitate widespread adoption and inspire continual data-driven workflow improvement as the product is used over time.

4.4.1 Automating the IVR finesse contextualization

The flow of the call is important. In most cases, the patient leads with their inquiry, and the CSR guides them to ensure they meet all of the requirements of a call. For example, when the CSR answers the phone, the patient generally communicates their inquiry. Before resolving the patient's inquiry, the CSR is required to complete patient authentication and ask the patient to identify themselves. After reviewing many calls, CSRs generally ask the patient to confirm who they are and what they need help with before continuing authentication if authentication was incomplete within the IVR. Performing and acknowledging the IVR analysis on each call can improve customer satisfaction. To allow for a more humanized call flow, the CSR will allow the patient to explain their inquiry before they complete the authentication process if necessary. In the design phase, it was clear that the IVR analysis should be standard, but it was also clear, that the IVR analysis should be more automated and clearer to the CSR.

To allow for IVR analysis automation, autologic triangle modules were developed within the decision support tool. Additionally, upon initialization of the decision support tool, procedural code searches for an open instance of the Cisco Finesse website in an internet explorer tab. If an open instance exists, the code extracts and parses HTML from the website. This information is stored as Finesse variables within the decision support tool application. Storing the information is important because it allows the application to analyze it and make preprogrammed data driven decisions while guiding the CSR through the call.

Autologic triangle modules allow the decision support workflow developer to evaluate variables and create simple if then statements by combining these autologic triangle modules with connector modules that ensure the tree diverges based on the answer to the autologic triangle modules. The picture below shows an example of autologic process triangles assessing Finesse variable information in a waterfall pattern. The autologic modules are shown in red. The autologic modules provide binary answers. When developing complex decision support tools that require analysis on multiple variables where certain combinations of variables mean different decision tree routes, an autologic module waterfall allows the developer to take the simplified autologic modules and answer complex questions involving multiple variables. If a CSR reviewed the Finesse variables, they would be able to determine if variable “A” equaled “X”, “Y”, or “Z”. They could use one decision node to determine the value. However, using the simplified autologic modules, there would need to be an autologic module waterfall three triangles long. The first determining if variable “A” equals “X”, the next determining if variable “A” equals

“Y”, and the last determining if variable “A” equals “Z”. If the autologic module returns logic false, the decision support tool will proceed to the successive autologic module.

Upon receiving the call, the CSR will initialize the decision support tool and decision support tool will extract, parse and save the Cisco Finesse variables from the HTML on the opened Finesse website. Next, the autologic will review the Cisco Finesse variables to determine the appropriate scripting for the CSR. For example, in the figure below, the red autologic triangle modules are reviewing the last menu accessed Cisco Finesse variable to determine if the patient was attempting to refill a prescription. If the patient was attempting to refill their prescription, the decision support scripts the opening accordingly. Later in the call, the authentication Cisco Finesse variable is assessed. If the patient successfully authenticated in the automated IVR system, the CSR is scripted to thank the patient for authenticating, otherwise the CSR is scripted to tell the customer why they failed out of the system. This provides closure to the patient. This autologic is designed to quickly translate the complex variable combinations and reduce cognitive workload from the CSR perspective while simultaneously enhancing the customer experience and potentially reducing average handle time in the future by educating the patient on best practices while using the IVR system.

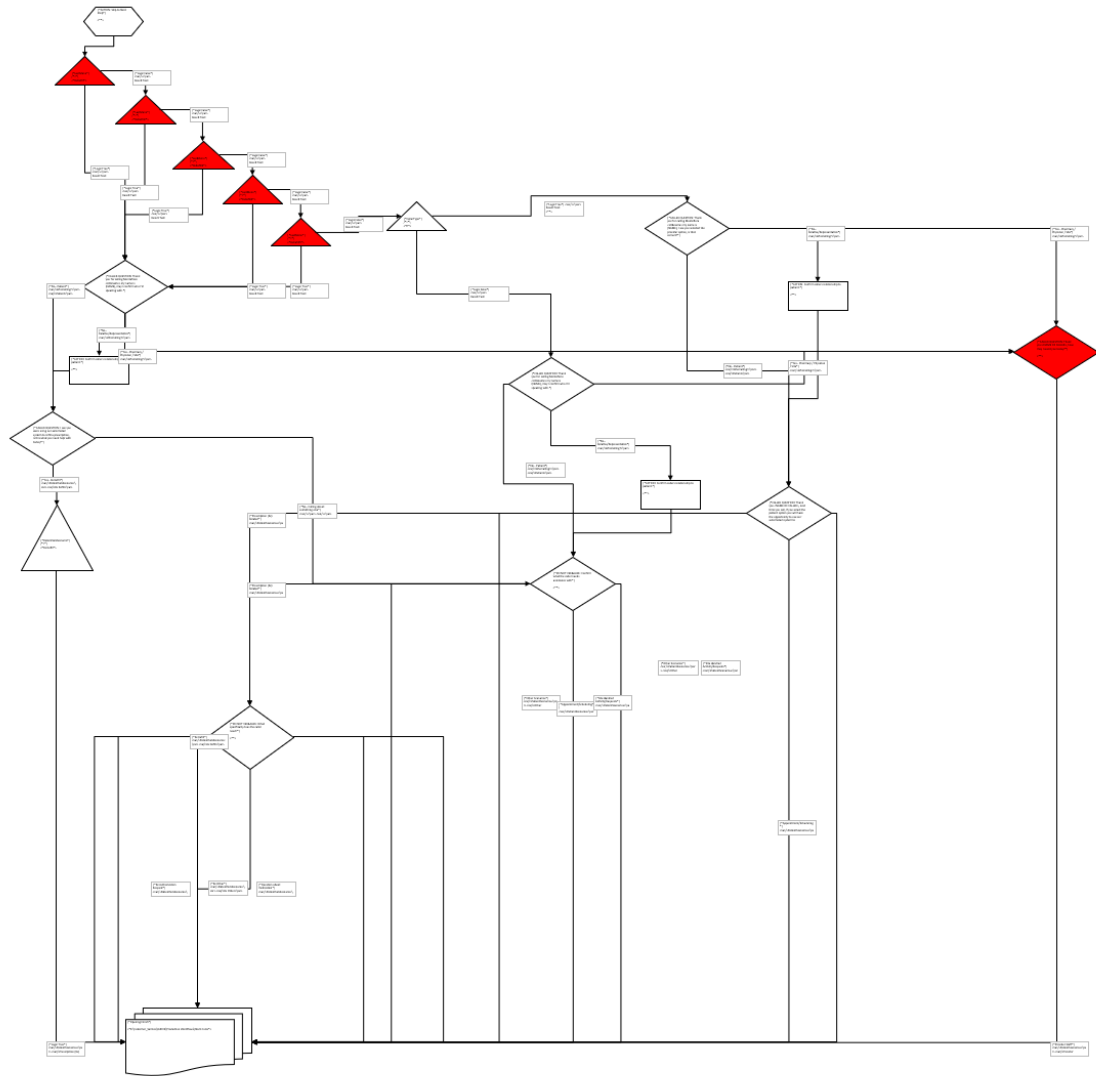

Figure 54: Opening Workflow: Autologic IVR Contextualization

4.4.2 CRM Scripting Automation

After developing the CRM database, one major concern was the navigability of the information within the database. To boost navigability for the CSRs, additional development was performed. CRM routing occurs in certain scenarios. While creating CRM routing workflows, the developer needs to place a system indicator to initiate the CRM routing experience. The indicator, “->@<- “is shown below. This indicator must be

located in the Action text box. The CSR is prompted to write any relevant text. The figure below shows an example where the CSR is prompted to enter the Medicines separated by commas. The script is located in the brackets: “[” and “]”. The information that the CSR writes in the text box will display in the area between the braces: “{” and “}”.

Edit Process Step Information

Please Enter the Action/Question. Use <CusName> to insert patient name when authentication is successful or {NAME} for CSL first name. Please select a type: ACTION:

Send CRM documenting the "pharmacy says no more refills" scenario as explained below. ->@<-|

Please enter any additional information for the CSL at the step (Optional). You can also add a message that will get copied by Using []. Withing the copied message you can use variables by adding brackets { }

Include: Name of RX, X day supply, which Pharmacies, any other pertinent information.[Patient requesting refill, pharmacy said there were no more refills: {Enter scenario in this format "Pharmacy: Med1 (X-day supply), Med2 (X-day supply)... " }]

SUBMIT EDIT CANCEL

Figure 55: Developer End CRM Scripting Initiator

When a CSR arrives at a point within the workflow where CRM scripting and routing are necessary, a pop up appears. The pop up allows the CSR to input important scenario related information. When the CSR fills in the information, they press “OK” to continue.

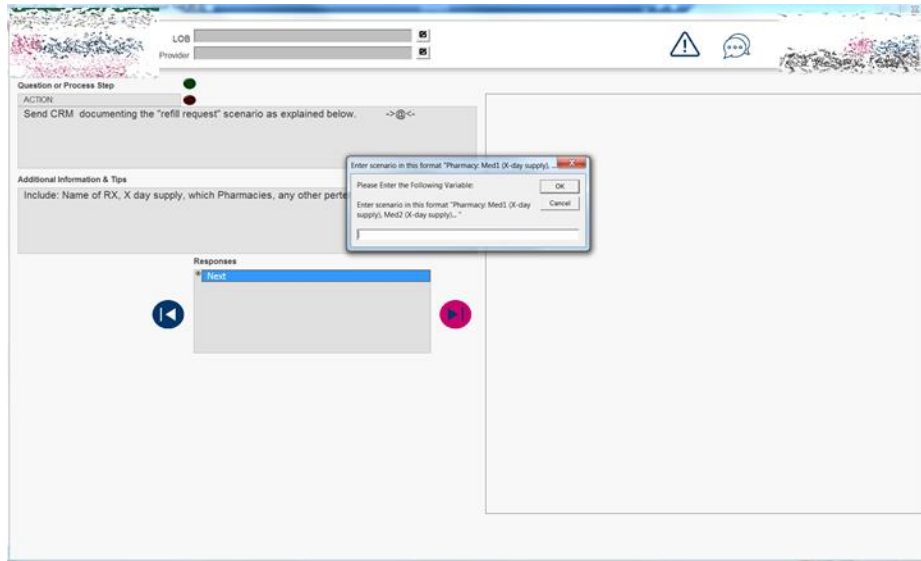

Figure 56: User End CRM Scripting Initialized

As the CSR continues, the decision support system reviews the text and notifies the CSR if they forgot to include the required information. This message appears when a CSR from leaves the scenario related information text box blank and attempts to continue “OK”. This reduces the number of CRMs sent containing errors.

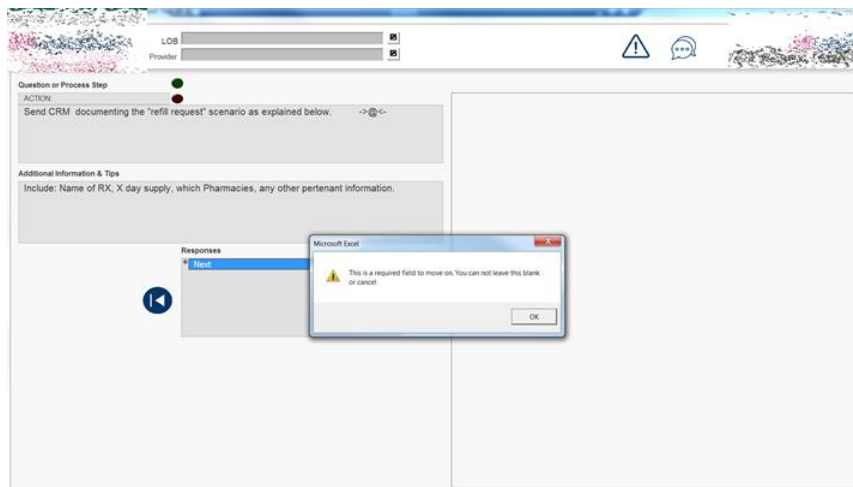

Figure 57: Medicine Names Left Blank

A physician can work in two lines of businesses. For example, a pediatric urologist can work in the department of Pediatrics and also work in the department of Urology. To return the proper CRM pool from the automated CRM routing database lookup, the decision support tool must obtain the line of business prior to initiating the lookup. Generally, this field will be auto-filled after obtaining the information from the Finesse variable parsing. If the Line of Business is not defined automatically, the CSR can manually fill this field.

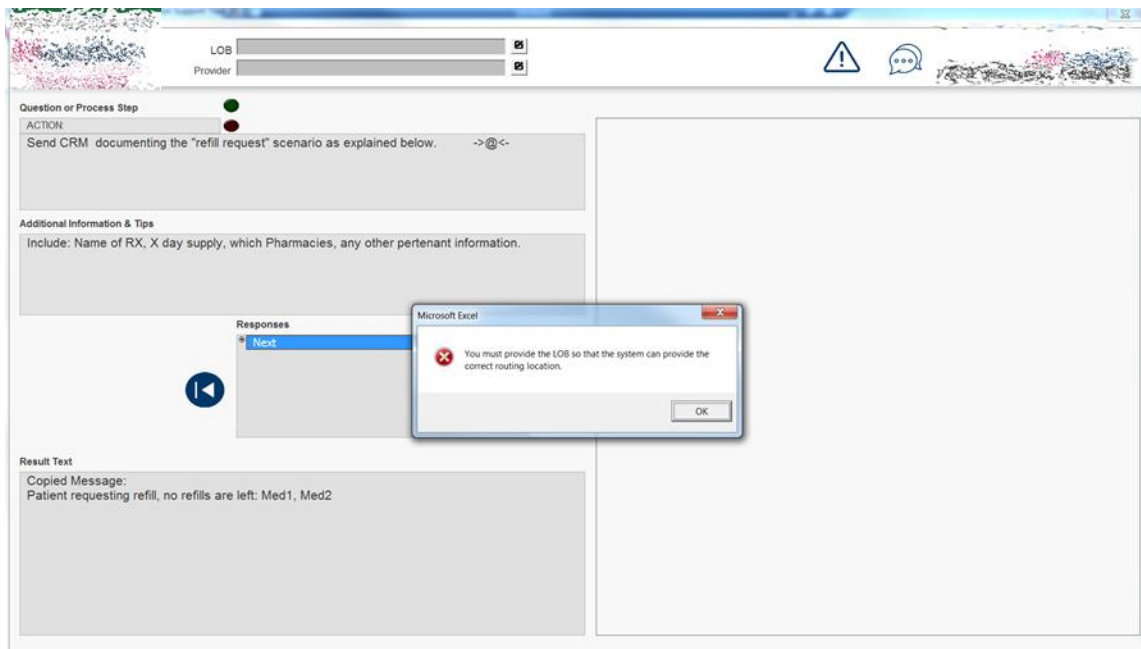

Figure 58: Line of Business Indicator Left Blank

To manually fill the line of business field, the CSR will click on the LOB search box indicated in red on the figure below, and then the CSR will choose the correct line of business from a dropdown list which is automatically pulled from the LOB table in the CRM routing database.

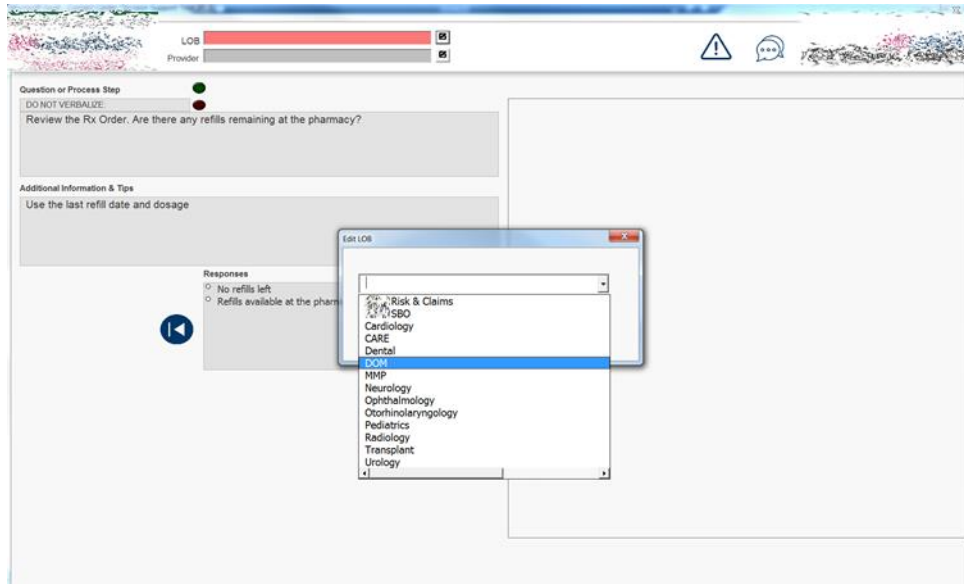

Figure 59: Line of Business Indicator Drop Down (Pulled From CRM Database)

If the line of business is defined but the provider field is not, a similar pop up message will occur that ensures the CSR manually chooses a provider.

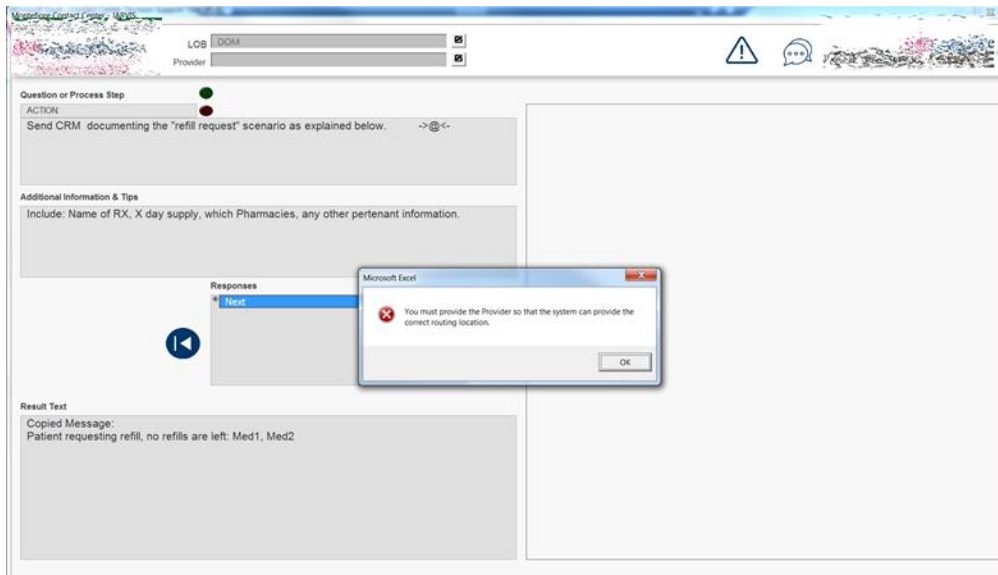

Figure 60: Provider Indicator Left Blank

After clicking on the provider field indicated in red in the figure below, the CSR will choose between the providers from that line of business. This dropdown selection is auto-generated from the list of providers in the CRM routing database who practice for the designated line of business.

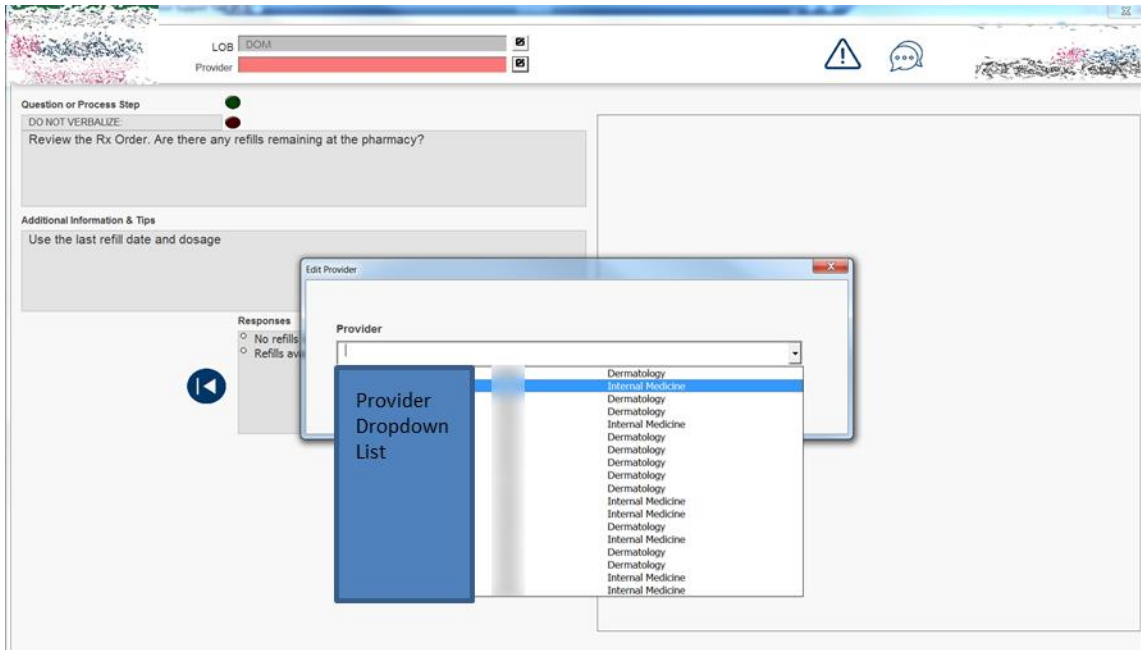

Figure 61: Provider Indicator Drop Down (Pulled From CRM Database)

After the line of business and provider are identified, the decision support tool prompts the user to enter the required scenario related information, and then performs an automatic lookup within the database for the proper CRM pool. The resulting scripted message appears in the result text box in the GUI and is automatically copied into the CSR's clipboard.

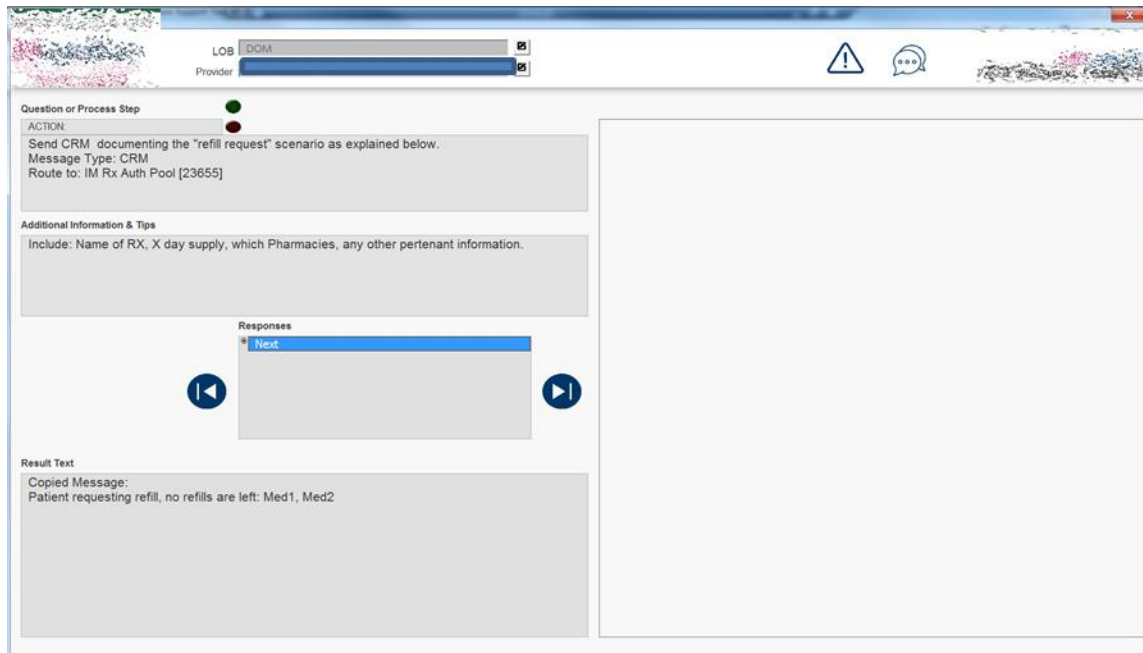

Figure 62: CRM Scripting and Pool Identification

The utilization of this feature automates the lookup process for CRM routing which can often be complex. This reduces the time to look-up the CRM routing information in comparison to opening a separate database and navigating to find the appropriate pool. It also helps the developer script CRM messages based on specific scenario. Often, CRMs may not include important information or context. But this tool prompts the CSR to input all the required fields in a more structured manner. Altogether, this CRM scripting and routing feature within the decision support tool automates processes and provides valuable and related information. Ultimately, this feature will help facilitate the adoption of the product.

4.4.3 Feedback Collection

In chapter four, the development of the timestamp and feedback collection database was discussed. Capturing and mapping, standardizing, and designing all possible scenarios

and workflows is nearly impossible. It is likely that the developer will miss certain workflows. In the absence of these workflows, a CSR may not be able to complete a call or may have to escalate or spend more time looking information up in guidelines. If this occurs frequently, average handle time will increase rapidly, and this will also act as a hindrance for widespread adoption of the decision support tool. While scenarios like this are inevitable, their frequency can be reduced if the developer allows CSR feedback to be easily accepted and frequently reviewed. When scenarios and workflows are not found within the decision support tool, the CSR can use the feedback button described in Chapter four. In some cases, the developer may want to prompt the CSR to use the decision support tool. In the example displayed in the figure below, a developer designs a decision module that leads to multiple scenario possibilities, but the developer knows that not all possible scenarios are outlined. So, the developer creates an extra scenario labeled “Appointment Type Not Listed”. If the CSR clicks on appointment type not listed, they are prompted to use the feedback button to alert the developer of other possible scenarios that need to be added into the tool.

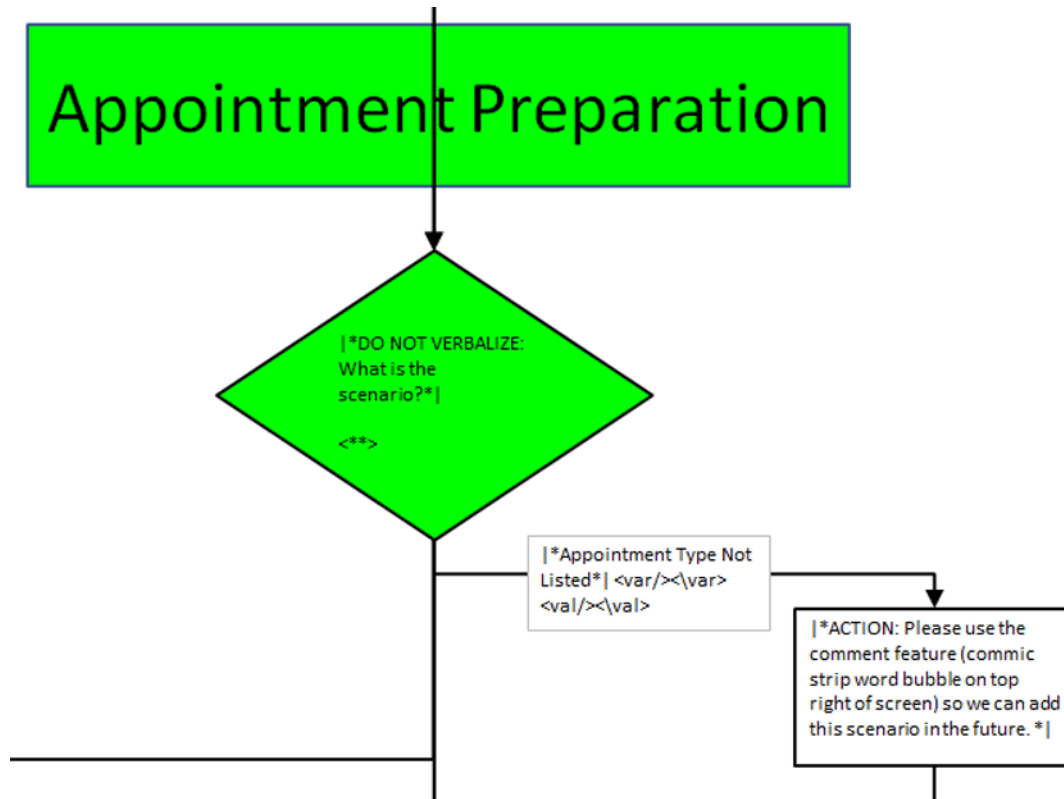

Figure 63: Leave Feedback Request

The features outlined in the design phase enhance the user experience, automate processes, and enable communication between the CSR and the developer to drive workflow improvement initiatives, reduce cognitive workload, potentially reduce average handle time, and facilitate a higher likelihood of widespread user acceptance.

4.5 Phase Five: Evaluate

Baseline and future state simulation models were developed to understand how using decision support to create a universal liaison and a truly centralized contact center will affect the customer. Sensitivity analysis was also performed to understand the limitations of the future state environment. The predicted limitations of the future state environment allowed for the development of requirements around average handle time

increases, and extra call volume allotment before the future state system loses the return on investment. This analysis led to a revisit of certain projects within the standardization and design phases of this case study to ensure the requirements of the future state are met or exceeded.

The studied contact center accepts calls Monday through Friday between the hours of 8 AM and 6 PM eastern standard time. In some cases, CSRs are available to work before or after these times. For example, patients may enter the queue before 6 PM, and a CSR will wait until the queue is empty before leaving for the day. The simulation outputs studied are the CSR average utilization, the average handle time, the patient wait time in the queue, and the number of calls handled. One model replication runs from 7 AM Monday June 5th, 2017 to 11:59 PM Sunday June 11th, 2017.

4.5.1 Problem Definition

The difference in environment before and after centralizing the contact center through the use of universal liaisons was the problem studied. With a decision support tool, each CSR would theoretically have the ability to answer any call. The following is a list of studied features studied in the current and future states:

1. Patient Wait Time: The number of seconds a patient waits after exiting the IVR system and before being attended to by a CSR
2. CSR Scheduled Utilization: The percentage of time a CSR is handling a call or performing call related work during their scheduled hours

3. Effect of Increased Calls on Patient Wait Time: In the future state, the average patient wait time is low for most calls. The effects of increased volume are studied to understand the ability for the system to accept additional calls.

4.5.2 Introduction to Model Jargon

The following table introduces model terminology, defines the terminology and provides examples.

Table 7: Contact Center Terminology

Terminology	Definition
Logged-in time	The number of seconds within a timeframe that a CSR is logged into the Cisco telephony system
Idle Time	The number of seconds within a timeframe that a CSR is in an idle state on the Cisco telephony system
Internal Task Time	The number of seconds within a timeframe that a CSR is marked as performing an internal task within the Cisco telephony system
Outbound Call Time	The number of seconds within a timeframe that a CSR is marked as performing an outbound call within the Cisco telephony system
Available Time	The number of seconds within a timeframe that a CSR is available to take a patient's call
In Call Time	The number of seconds within a time frame that a CSR either talk to a patient, placed the patient on hold or wrapped up the patient's call
Talk Time	The number of seconds a CSR spends talking with a patient during a specific call.
Hold Time	The number of seconds a CSR places a patient on hold during a specific call.
Wrap Time	The number of seconds a CSR takes to wrap up any outstanding documentation or work that a call produces after the patient hangs the phone up
Event Duration	The summation of talk time, hold time, and wrap time for a single call

Abandoned Call	A call where the patient hangs up while in the queue, before reaching an available CSR
Patient Wait Time	The number of seconds a patient waits after exiting the IVR system until their call is answered by an available CSR
Average Speed to Answer (ASA)	Patient wait time
Average Handle Time (AHT)	Event duration
Otorhinolaryngology (Oto)	“Oto” is shorthand for “Otorhinolaryngology” (a specialty in the healthcare contact center setting)
Abandonment Rate (ABA)	The percentage of calls that were abandoned before reaching a CSR

4.5.3 Baseline Model

The simulation baseline model was developed using Arena software. The baseline ran for 52 replications of a 1-week period. Each day lasted 24 hours. Staffing at the studied contact center is generally 8 AM to 6 PM. Staffing numbers were calculated by hour from actual data and inputted into the model. Incoming calls were calculated as volume per hour over the 1-week period. Incoming call arrival data was distributed in terms of actual calls arrived within each hour.

4.5.4 Baseline Conceptual Model

In the baseline model, when a call exits the IVR system, it enters into a queue staffed by skilled CSRs. When a CSR is available to take the call, the call is forwarded to the CSR. Otherwise the call waits in the queue until a CSR is available to take the call or the contact center closes. If the contact center closes before the call is handled, the call will be kicked

out of the system, so it doesn't inflate the wait time output measure. If the call is answered by a skilled CSR, the call is handled based on a predetermined distribution. This includes call talk, hold, and wrap times. If the contact center closes before the call is complete, the CSR completes the call and then ends their shift. After the call is handled, the call is considered complete and the CSR resource is released and available to take the next call unless their shift has ended.

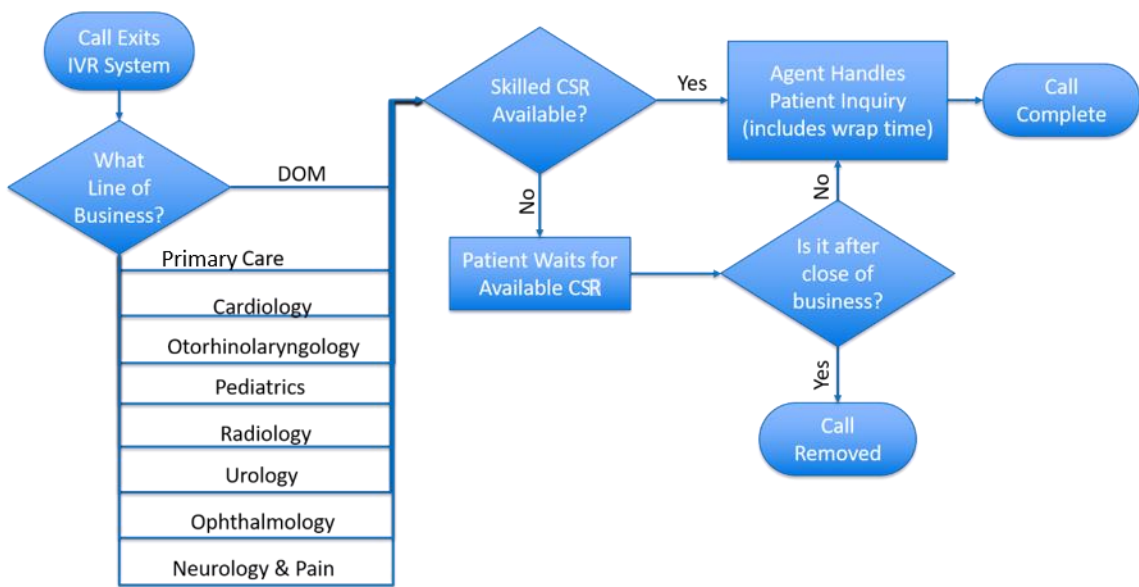

Figure 64: Baseline Conceptual Model

In the future stare model, the call enters the model after exiting the IVR system. The call is routed to the next available resource regardless of queue because all CSRs are skilled to handle all call types through the use of the decision support tool. When a CSR is available to take the call, the call is forwarded to the CSR. Otherwise the call waits in the queue until a CSR is available to take the call or the contact center closes. If the contact center closes before the call is handled, the call will be kicked out of the system, so it doesn't inflate the wait time output measure. If the call is answered by a skilled CSR, the

call is handled based on a predetermined distribution. This includes call talk, hold, and wrap times. If the contact center closes before the CL is complete, the CSR completes the call and then ends their shift. After the call is handled, the call is considered complete and the CSR resource is released and available to take the next call unless their shift has ended.

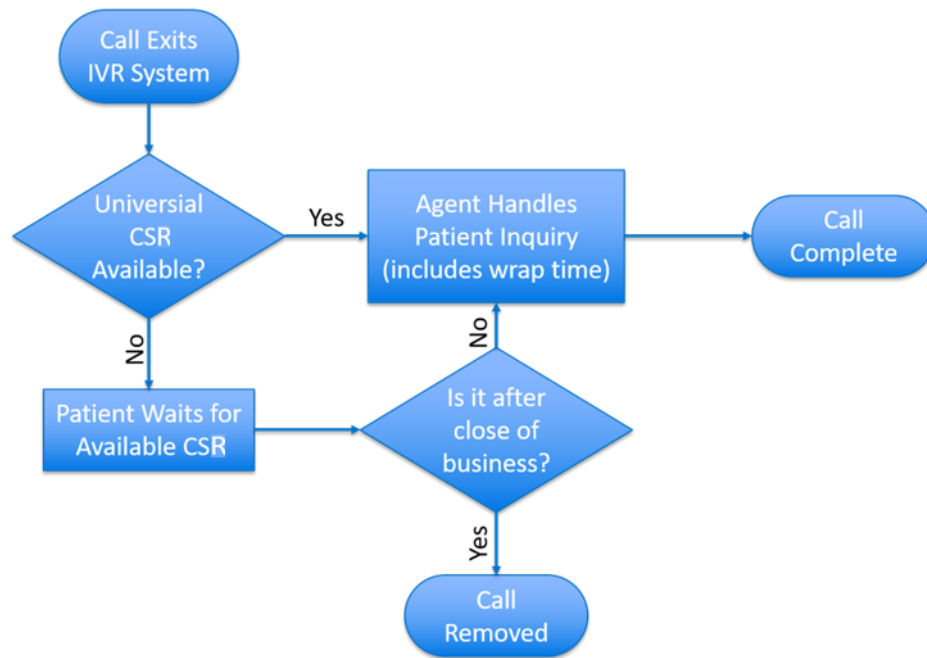

Figure 65: Future State Conceptual Model

4.5.5 Arena Model

The Arena model is composed of three major parts: the call kick out, the baseline model and the future state model. The call kick out is the blue part of the figure below labeled “Remove Calls After Close of Business”. The baseline model consists of the yellow and orange parts in the figure below. Each section is an individual queue. The Future state is within the red box in the figure below. The future state depicts a contact center that has a centralized workforce staffing Universal CSRs which is facilitated through the use of the

developed decision support tool. The arena model call flow was validated by subject matter experts.

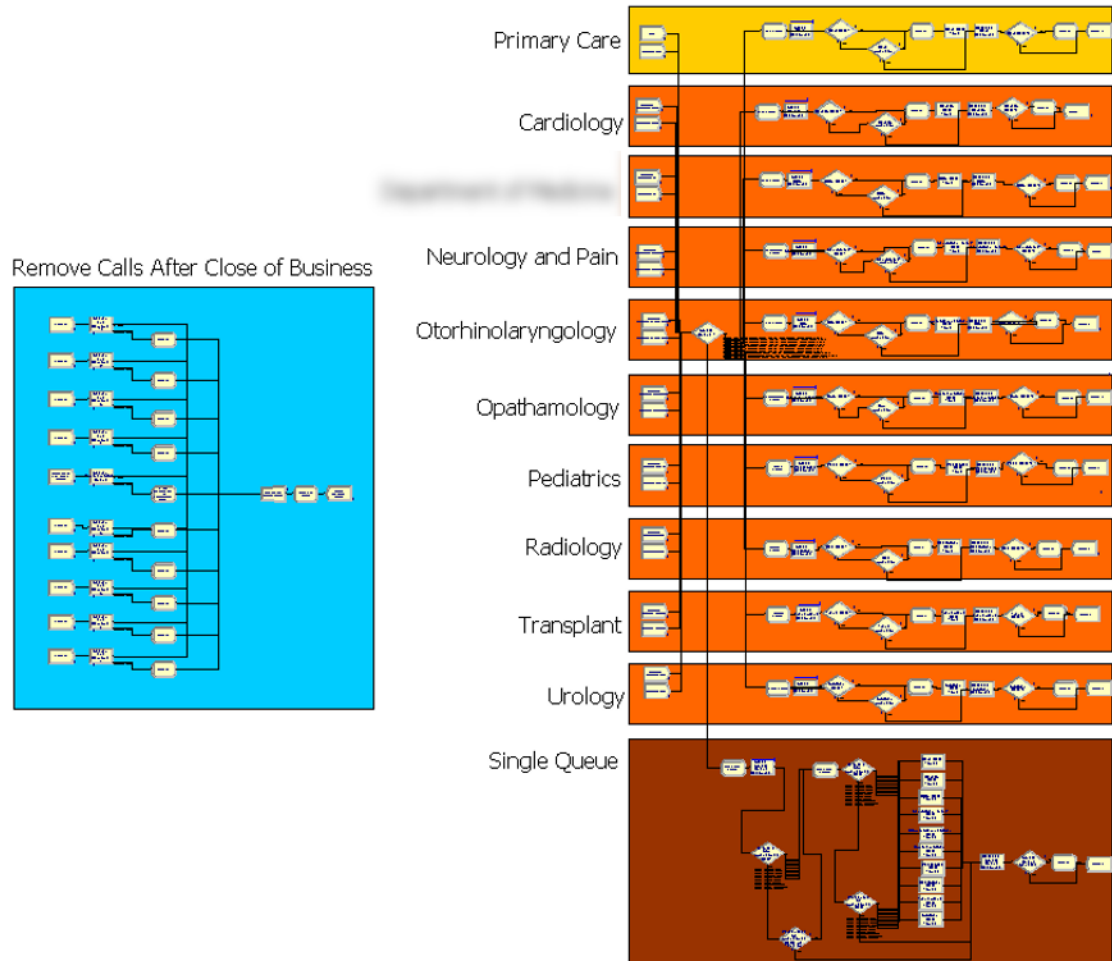

Figure 66: Contact Center Arena Simulation Model

4.5.6 Primary Care Line of Business

The primary care portion of the Arena Model is depicted in the figure below. First the abandoned and answered primary care calls are created. Then, they are routed to an assign module that assigns a start time attribute to the entity. Next, the entity enters the primary care CSR resource queue. When a primary care CSR is available to answer a

patient’s inquiry, the entity leaves the queue and claims a primary care CSR resource. Next, the entity is assessed to determine if it is an abandoned call or an answered call. If it is an abandoned call, it enters a second decide module that assesses a user defined variable called abandoned calls answered. It is a two way decide module based on the abandoned calls answered percentage. If answered calls percentage equals zero, which is true for the baseline model, the call is forwarded to the primary care CSR resource release module. If the abandoned calls answered percentage is greater than zero, some calls will enter the assign module. If the entity enters the assign module, this calculates the entities’ wait time, assigns an attribute indicating that the call was handled, and assigns a new value to the wait time variable. This module also assigns an attribute defining the call’s start time. If the call is not an abandoned call, it will enter directly into the assign module then go into the primary care handle time module and be delayed based on the hand time distribution. Next, these calls will enter the CSR release module, releasing the primary care resource. If the call was handled, the entity will pass through an assign module that tracks the amount of time the process took. Otherwise, the entity will be disposed of.

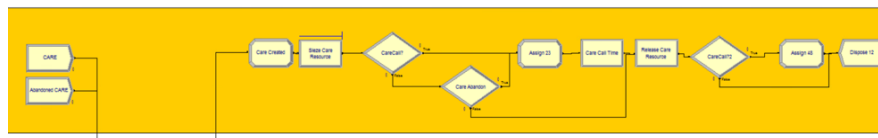

Figure 67: Primary Care

4.5.7 Specialty Care

The specialty care portion of the model acts in the same fashion as the primary care portion of the model. There are nine modeled specialty care departments within the contact center.

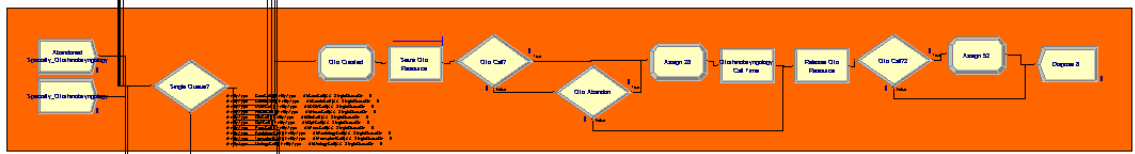

Figure 68: Specialty Care

4.6 After Hours Call Kick Out

When the contact center shuts down, it stops accepting patients through the IVR system. In some cases, using the simulated model, during high wait times, some calls may arrive in the queue and not be answered by a CSR before the end of the CSR’s shift. In the simulated model, the calls do not exit the system until they are addressed by CSRs the following morning. This is not an accurate representation of the contact center system. To make the model more accurately represent the contact center system, at the end of each shift, an entity is produced for each line of business. Each entity enters into a search and remove module. In the search and remove module. The model searches for all instances of entities remaining in the respective queue. If an instance is found, it is removed and enters into an assign module that increases the count of removed entities. Then, any batched or segmented entities are separated, and enter into an assign module that counts the number of entities that exit the kick out part of the model. Finally, these entities are disposed enter a dispose module and exit the system.

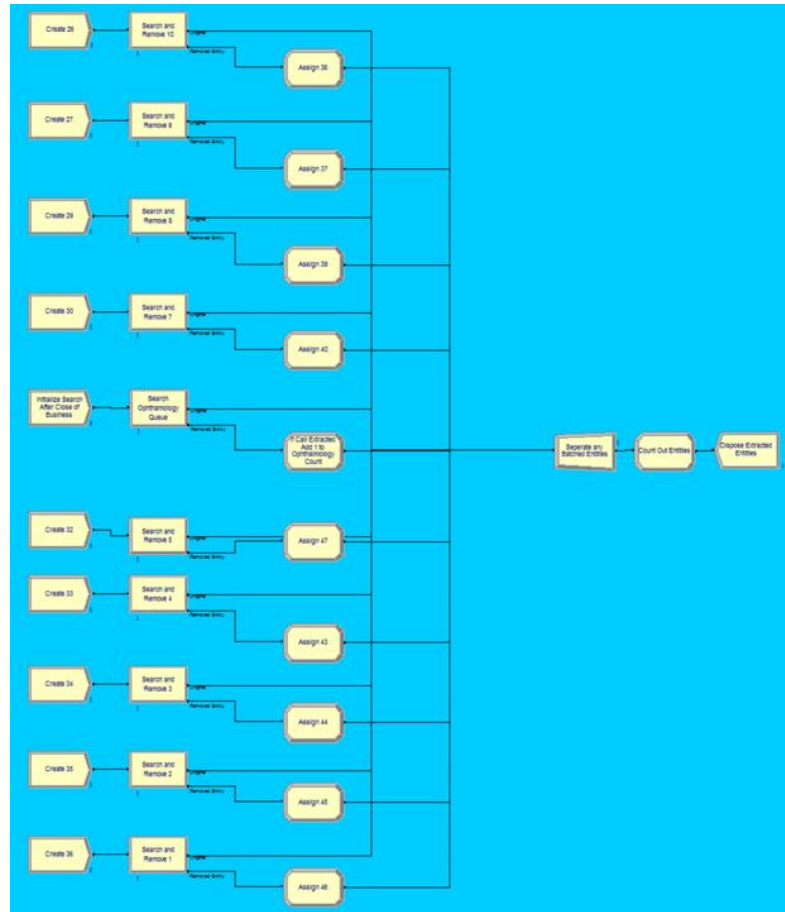

Figure 69: Call Kick Out

The kick out creation is determined on a schedule. For the first 13 hours of the day, or between 7 AM and 8 PM, zero entities are created. Between 8 PM and 9 PM, one entity is created. This initiates the kick out procedure for any calls left in the queue for the corresponding line of business. Then, zero entities are created for the following 23 hours, then one for the following one hour and so on. Every day between 8 PM and 9 PM, one kickout entity is created for each line of business.

Durations		
	Value	Duration
1	0	13
2	1	1
3	0	10
4	0	13
5	1	1
6	0	10
7	0	13
8	1	1
9	0	10
10	0	13
11	1	1
12	0	10
13	0	13
14	1	1
15	0	10

Schedule - Basic Process				
	Name	Type	Time Units	Scale Factor
31	Kick Out Schedule	Arrival	Hours	1.0

Figure 70: Close of Business Call Kick Out

4.6.1 Assumptions

When developing a model to match a real-world environment, many assumptions must be made to simplify the complex behaviors seen in a contact center. The following list specifies the assumptions made to produce the baseline and future state models. Assumptions were validated by subject matter experts.

1. Spanish and English calls are routed to the next available CSR.
 - a. In the studied contact center, calls are routed to the next available CSR regardless of if the CSR is skilled to speak in Spanish. If the call is in Spanish and the CSR is not bilingual, they call a third-party translation service to communicate with the patient.
2. Calls do not abandon the queue based on time the patient is waiting.
 - a. In some cases, the average patient wait time is larger than the average time until the patient abandons the call. When abandonment rate based on wait time was considered, the abandonment rate in the model was double the abandonment rate

from the actual data causing the handled volume and the modeled wait time to decrease.

3. Talk time, hold time, and wrap time are summed to create event duration. Event duration for each call is used to create the event duration distribution for each line of business.
 - a. When talk time, hold time, and wrap time were modeled separately, error rates for each distribution accumulated, and the resulting modeled average event duration deviated too far from the actual average event duration. To simplify the model, talk time, hold time, and wrap time were summed to create the event duration.
4. Calls arriving to the 10 modeled lines of business are considered.
 - a. While the contact center services billing needs of customers and serves a dental practice, only relevant calls were considered. The billing and dental lines of business were not modeled because a CSR needs to learn different software to serve these departments. This would make centralization for these departments complex.
5. Staff rates by hour are rounded to the nearest integer.

Staffing is calculated through determining the total time available to take calls between all CSRs in each line of business. Rounding must occur to ensure the scheduled utilization calculation is accurate.

4.6.2 Input Parameters

Input parameters are the values programmed into the model. They are the basis for how the model operates. In this model, the input parameters were based off of observed contact center data.

4.6.3 Call Arrivals

Call arrival data is complex and changes throughout the day. Creating a call arrival distribution is impractical because arrival is seasonal and changes on an hourly and daily basis. Calls arrival data was extracted from Cisco telephony data. Abandoned calls were not considered in the extraction of call arrivals. In many cases, the average time before abandoning was much lower than the average customer wait time. When abandoned calls were considered in this model, the abandonment rate output was often double the rate of abandonment in the contact center system. Call event data for answered calls was extracted from the Cisco telephony system. Each call had a field that identified the arrival time when the call exited the IVR system and entered into a queue. For each call, the hour and day of week was determined. Then, the data was displayed in an Excel pivot table. The pivot table displayed the count of answered calls appearing during each day at each hour. This data was inputted into an Arena arrival schedule for the corresponding line of business. The time unit was set to hours, and the scale factor was equal to one for each line of business. To model the arrival of abandoned calls, the scale factor was equal to the percentage of total call volume that was abandoned for that line of business.

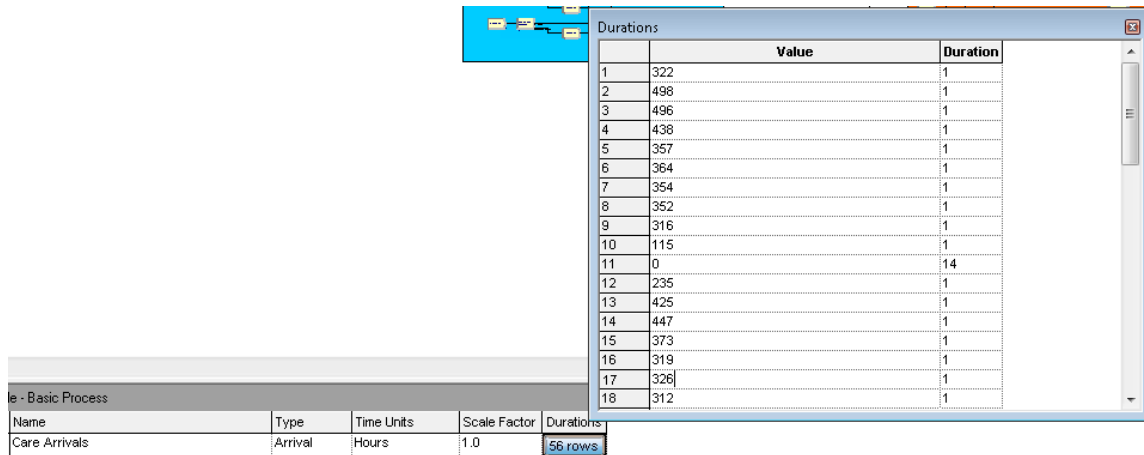

Figure 71: Call Arrivals in Arena Model

4.6.3.1 Incoming Calls Output Analysis

To validate the model, call arrivals data was compared to the modeled call arrival output. The modeled call arrivals matched the actual call arrivals with all error rates below one half of a percentage point. Additionally, the incoming calls were observed through animation and the number of modeled arrivals each hour matched the number of actual arrivals each hour.

Table 8: Simulated and Actual Incoming Call Volume and Percentage Error

Department	Incoming Calls Actual	Incoming calls Model	Error Rate
Cardiology	1481	1482.7	0.12%
Primary Care	16091	16079.3	0.07%
Department of Medicine	5323	5315.2	0.15%
Neuro/MMP	1012	1009.0	0.29%
Ophthalmology	2124	2126.5	0.12%
Oto	1495	1495.5	0.03%
Pediatrics	1286	1284.5	0.12%
Radiology	4190	4197.0	0.17%
Transplant	670	672.7	0.40%
Urology	1482	1480.3	0.11%

The graph below shows the relationship between the actual and average modeled incoming calls for the 52 one-week long replications. The average modeled incoming calls match the actual expected number of incoming calls.

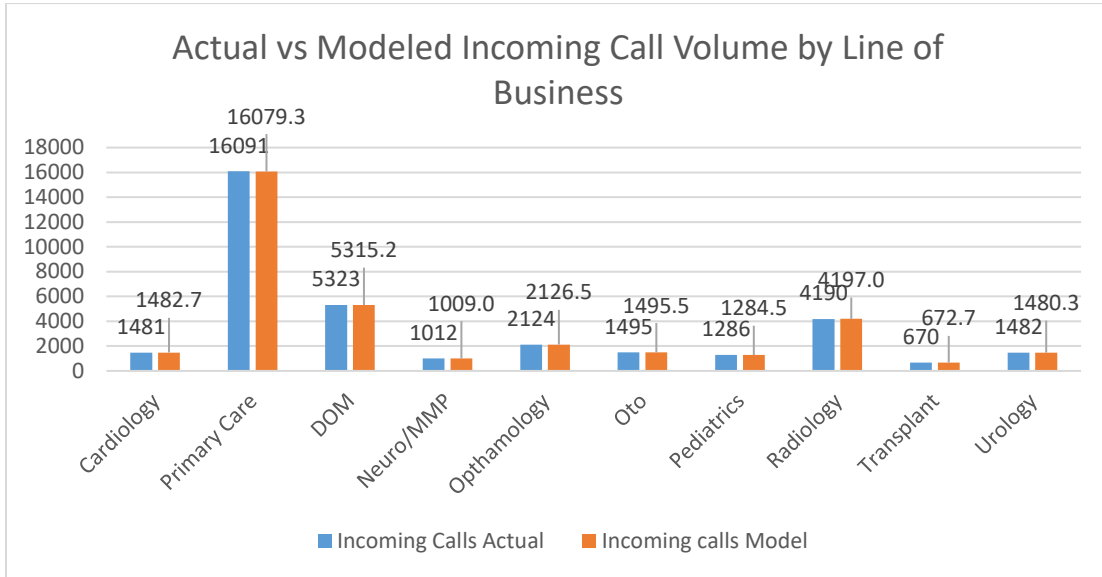

Figure 72: Simulated and Actual Incoming Call Volume

The graph below shows the error rate between the actual incoming calls and the average modeled incoming calls. All error rates are below one half of a percentage point. After viewing this data and viewing the animation to ensure the model creates the entities at the appropriate times, the modeled arrival rate is considered validated.

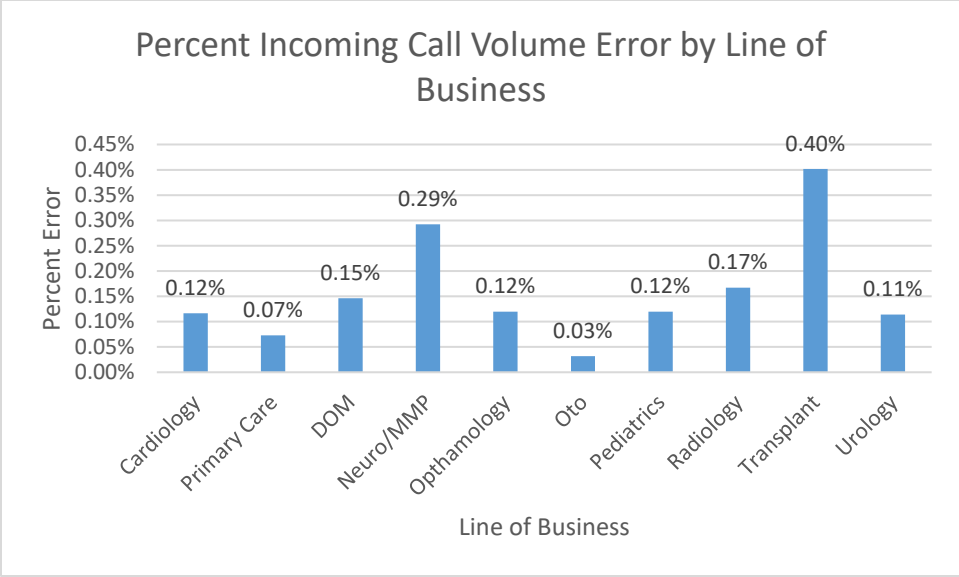

Figure 73: Incoming Call Volume Percentage Error

4.6.3.2 CSR Staffing

CSR staffing data was extracted from Cisco telephony data. CSR staffing differs throughout the day. To be considered a resource, a CSR must be logged into the system; they must be not in an idle state, performing internal tasks, or on an outbound call. To determine the number of CSRs available or on a call for each hour of each day, detailed event data was pulled and separated into the total time of CSRs logged into the system, the total idle time, the total internal task time and the total outbound call time. Next, these events were summed up by hour by line of business. Then, the total idle time, internal task time and outbound call time was subtracted from the total logged in time for each hour. The result was calculated as the total number of seconds any CSR within that line of business was available to take a call during each hour. Next, the result of this calculation was divided by 60 to obtain the number of minutes a CSR was available, and then divided by 60 again to obtain the number of CSRs available for that specific line of business. Any

value that was not an integer was rounded to the nearest integer. The staffing integers were then loaded into their corresponding Arena capacity-based schedule and the time unit was defined as hours with a scale factor of one. To ensure the output accuracy, the number of CSRs available to take calls each hour was animated in the Arena model and observed. Each hour, the correct number of CSRs was staffed and available to answer calls.

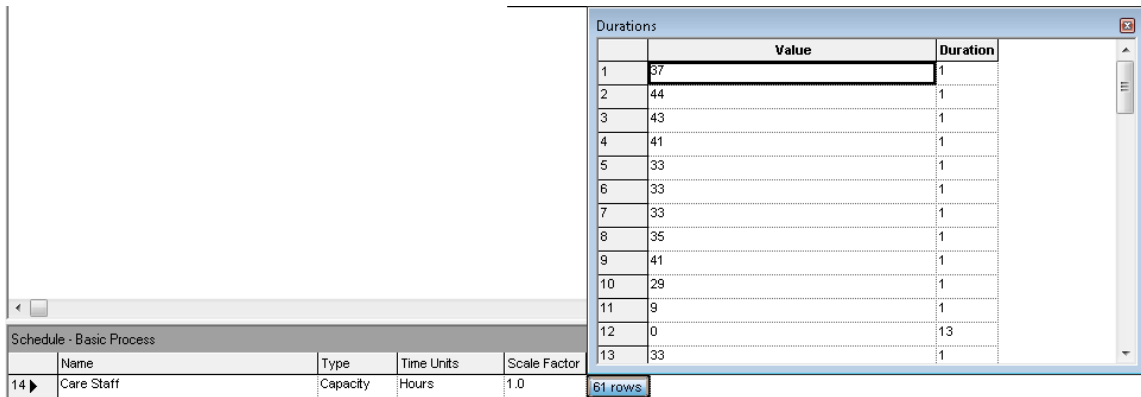

Figure 74: Staffing in Arena Model

4.6.3.3 Handle Time Distributions

To determine handle time distributions, the call data was extracted from the Cisco telephony system. The call event data displays the number of seconds a caller is placed on hold, the number of seconds the caller is talking to the CSR and the number of seconds it takes to wrap up the call. Originally, the distribution for talk time, hold time, and wrap time was determined, validated and inputted to the model. The likelihood of a call going into wrap time or hold time was determined before the call entity entered into the distribution delays. To assure the inputs were accurate, for each distribution in each line of business, 52 samples of the distribution were recorded and compared to the actual talk times, hold times and wrap times observed in the system using sample t-test functionality of Minitab

Minitab 18 software. All p-values were greater than .05 and the confidence intervals obtained from the chi-square tests contained 0. Thus, the test fails to reject the null hypothesis, meaning the estimated distributions match the actual data. However, during the output analysis phase, the resulting handle time was too different from the actual handle time. To simplify the model, the talk time, hold time and wrap time for each call was summed into the event time. The event time distribution for each line of business was determined using the Arena input analyzer.

4.6.4 Event Duration Distribution Validation

To assure the inputs were accurate, for each distribution in each line of business, 52 samples of the distribution were recorded and compared to the actual event durations observed in the system using sample t-test functionality of Minitab 18 software. All p-values were greater than .05 and the confidence intervals obtained from the chi-square tests contained 0. Thus, the test fails to reject the null hypothesis, meaning the estimated distributions match the actual data. During output analysis, the model's event duration times matched the actual event duration times. The deviation between modeled and actual average event duration times is marginal.

Table 9: Simulated and Actual Event Duration

Department	Actual Talk + Hold + Wrap Time (Seconds)	Simulated Talk + Hold + Wrap Time (Seconds)	Actual Talk + Hold + Wrap Time (Minutes)	Simulated Talk + Hold + Wrap Time (Minutes)
Cardiology	283.32	283.29	4.72	4.72
Primary Care	339.01	344.36	5.65	5.74
Department of Medicine	299.63	299.66	4.99	4.99
Neuro/MMP	253.96	257.27	4.23	4.29
Ophthalmology	233.45	233.45	3.89	3.89
Oto	280.45	280.4	4.67	4.67
Pediatrics	238.78	238.76	3.98	3.98
Radiology	273.26	273.27	4.55	4.55
Transplant	244.78	244.74	4.08	4.08
Urology	292.44	292.45	4.87	4.87

The graph below shows the difference in modeled and actual event duration times in seconds by line of business.

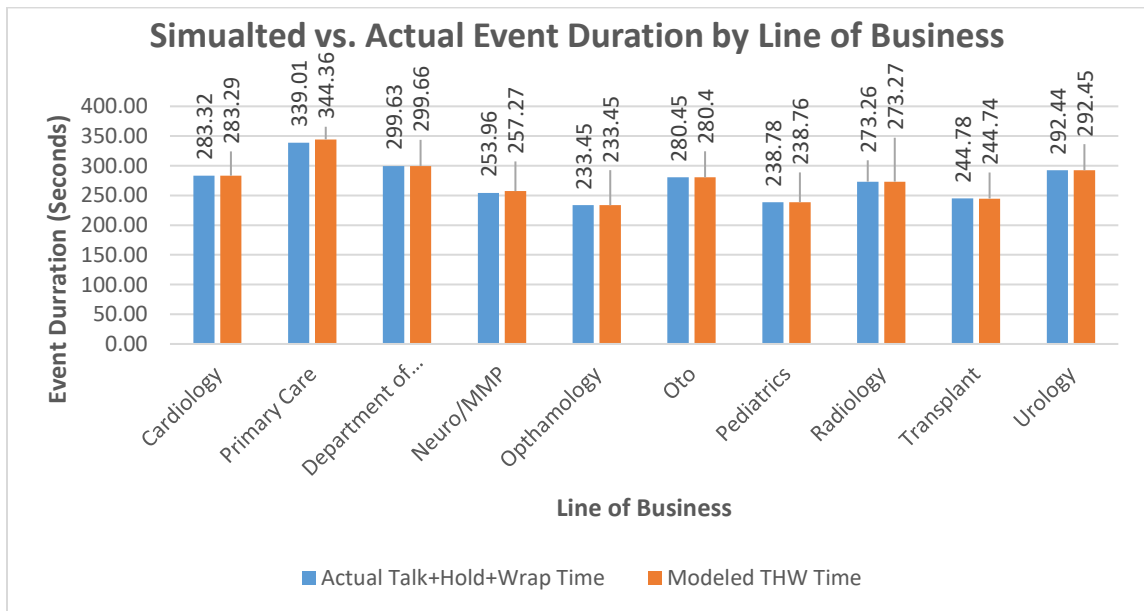

Figure 75: Simulated and Actual Event Duration

The graph below shows the error rate between the actual and modeled event duration. This is calculated by finding the absolute value of the modeled event duration subtracted by the actual event duration all over the actual event duration.

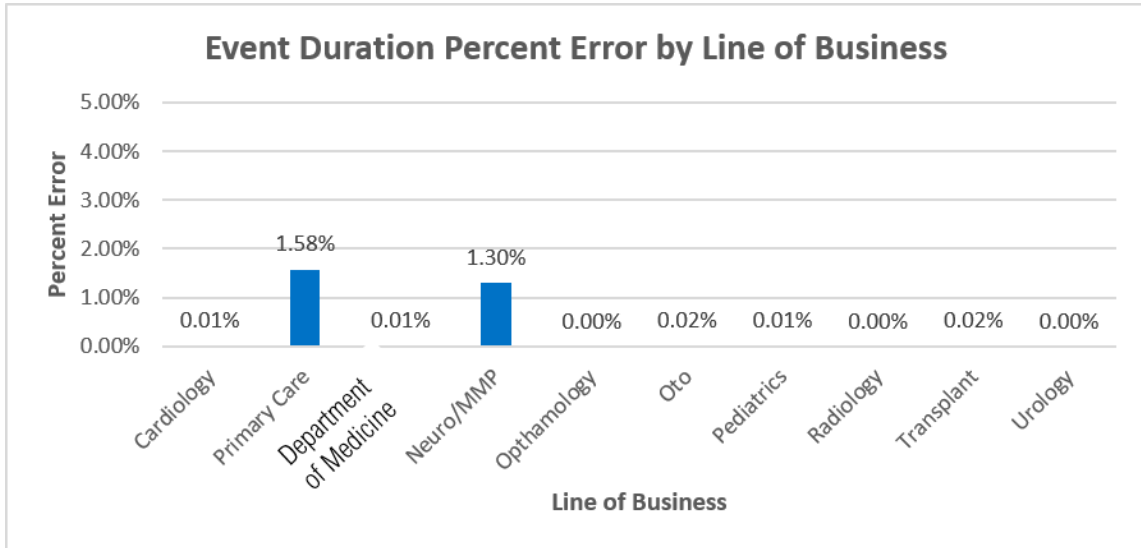

Figure 76: Event Duration Percentage Error

4.6.5 Patient Wait Time Baseline Analysis

Patient wait time is a key indicator used in the model. Actual wait times were compared to modeled wait times. For each line of business, an average simulated wait time was observed. The average simulated wait time and the half width were calculated. For all lines of business, the actual average wait time was existed between the simulated wait time plus the half width and the simulated wait time minus the half width.

Table 10: Simulated and Actual Average Wait Time and Percentage Error

Department	Actual Wait Time	Upper End	Lower End	Simulated Wait Time
Cardiology	9.926	12.2706	9.3306	10.8006
Primary Care	189.032	201.02	186.08	193.55
Department of Medicine	42.39	48.644	36.764	42.704
Neuro/MMP	18.538	23.9153	15.9553	19.9353
Ophthalmology	24.474	33.7784	20.7584	27.2684
Oto	36.529	43.0021	32.1021	37.5521
Pediatrics	13.737	15.3699	10.5099	12.9399
Radiology	25.394	28.4425	21.6425	25.0425
Urology	15.285	20.3539	14.0139	17.1839
Transplant	23.39	31.268	21.348	26.308

The graph below shows the actual average patient wait times by line of business via the blue columns. The simulated wait time and the associated half width are shown by the red rectangles and the black bars respectively.

Output Analysis: Simulated vs. Actual Average Patient Wait Times by Line of Business

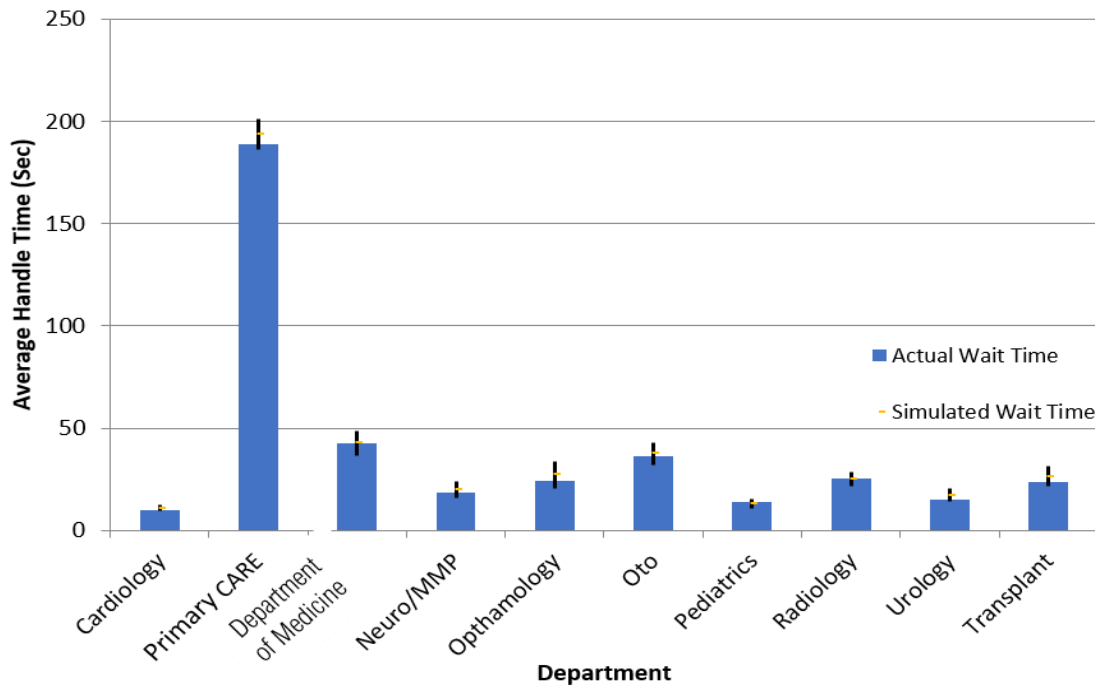

Figure 77: Simulated and Actual Average Wait Time

4.6.6 Future State Model

In the future state of the contact center, all CSRs are able to handle all calls through the use of the decision support system. When calls are created in the future state, they enter an assign module that assigns a time of queue entry attribute. Next, the call enters the single queue staffed with universal CSRs. Here, the call waits until a CSR can answer the call. Once the call obtains a resource, a decide module determines the number of abandoned calls that can enter the delay based on an abandoned rate acceptance variable preset by the model user. If the call is an answered call, it enters into an assign module that assigns the patient’s wait time to the single queue wait time variable, assigns the current time to the handle time attribute and assigns an attribute denoting that the call was handled. If the call

average patient wait time for any decentralized line of business was Cardiology at just under 10 seconds.

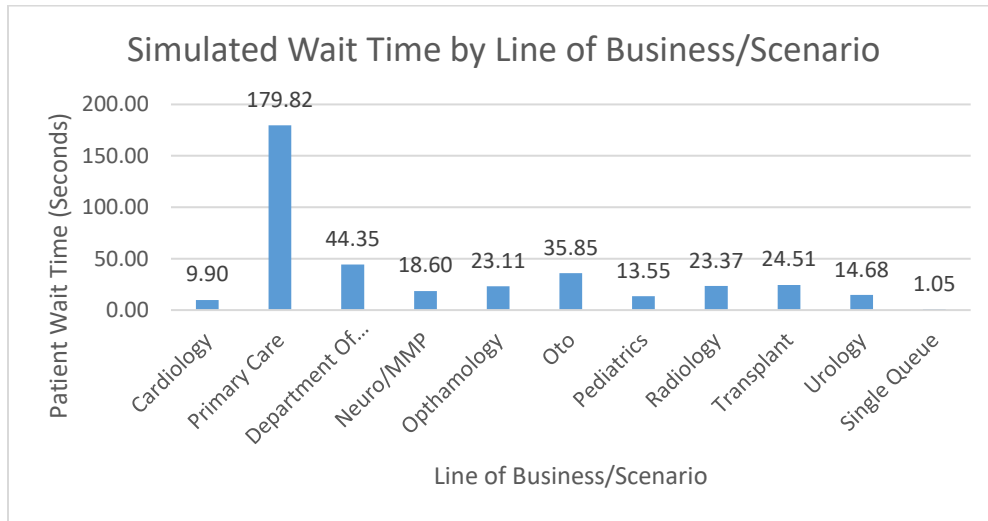

Figure 79: Simulated Wait Time by Line of Business and Scenario

To determine if these results were significantly different from the baseline, contact center, an overall patient wait time variable was assigned at each line of business upon the answered call being accepted by a CSR. Next, the baseline model ran for 52 replications. The average wait time across the contact center was obtained for each of these 52 replications. The average of the average wait times was 103.99 seconds with a half width of 4.92 seconds. Each of the replication values was collected and placed in a Minitab 18 workbook. Next, the future state single queue call center was run for 52 replications. The average for each replication was obtained and pasted into the same Minitab 18 workbook in a separate column. The average of the average wait time in the single, centralized queue system was 1.0478 seconds with a half width of 0.09 seconds. This replication was compared in Minitab 18 using a paired t-test to determine the confidence of these two models showing the same wait time. After performing a paired t-test with a confidence of

99%, zero did not exist within the 99% confidence interval, and the p-value was less than .01 which means the test rejects the null hypothesis that the current state and future state patient wait times are equal to each other. Therefore, the future state patient wait time is significantly lower than the current state wait time.

Paired T-Test and CI: Current State, Future State

Descriptive Statistics

Sample	N	Mean	StDev	SE Mean
Current State	52	103.99	17.66	2.45
Future State	52	1.05	0.36	0.05

Estimation for Paired Difference

Mean	StDev	SE Mean	99% CI for $\mu_{\text{difference}}$
102.94	17.66	2.45	(96.39, 109.50)

$\mu_{\text{difference}}$: mean of (Current State - Future State)

Test

Null hypothesis $H_0: \mu_{\text{difference}} = 0$

Alternative hypothesis $H_1: \mu_{\text{difference}} \neq 0$

T-Value	P-Value
42.03	0.000

Figure 80: Paired T-Test and Confidence Interval for Current State vs. Future State Patient Wait Time

4.6.8 Scheduled Utilization

Another marker of future state performance is the scheduled utilization for CSRs. In the current state, each line of business experiences a varying degree of scheduled utilization ranging from 40% to 88%. This means that CSRs working in primary care are utilized by patients more than two times as much as CSRs working in the Urology department. This is due to differences in call volume, handle time, and staffing between the two departments. In the future state, all CSRs will theoretically be utilized the same amount. The current state is designed in such a way where CSRs in one department can experience a vastly greater workload in comparison to CSRs from other departments. In the future state, each CSR will inherently experience the same utilization. In most departments, the future state version will utilize the CSR more effectively. In other departments, the future state will reduce the workload on the CSR.

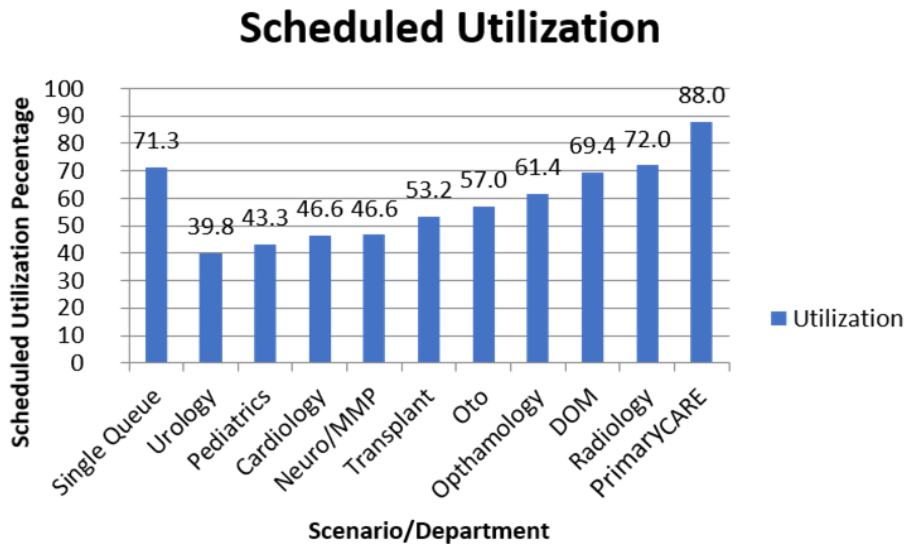

Figure 81: Average Scheduled Utilization by Department

To understand why the future state will increase the workload for CSRs in most departments and only decrease the workload for CSRs in two departments, volume is considered. Generally speaking, CSR utilization increases as call volume increases.



Figure 82: Number of Calls answered by Line of Business and Scenario

The graph below shows the relationship between call volume and CSR utilization by department. In the current state, generally speaking, as the number of calls increases, the utilization increases. This is likely due to a disparity in staffing in terms of handle time and volume of calls. Primary care receives the largest call volume, and the scheduled utilization is nearly 90%. In the future state, all available CSRs are pooled together. This means that, on average, all CSRs will handle a similar volume of calls, meaning the utilization between all CSRs becomes level loaded.

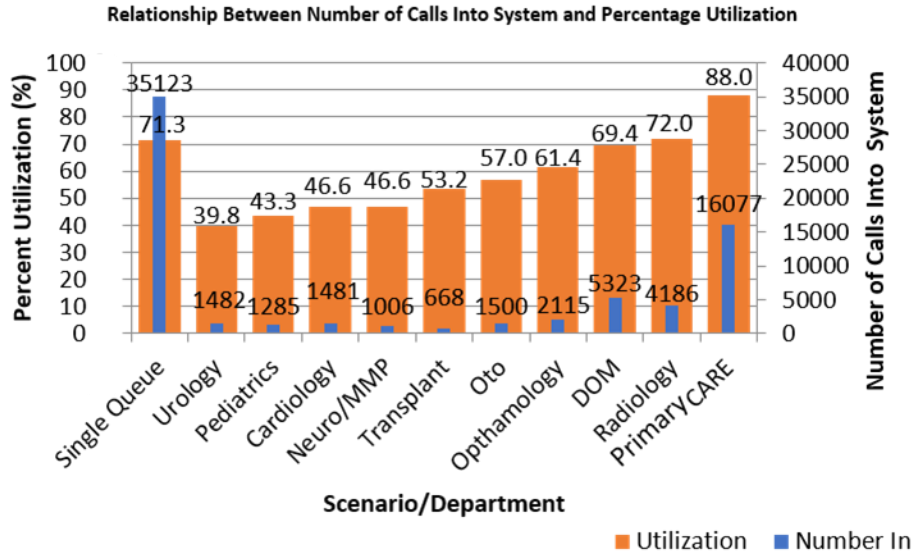

Figure 83: Number of calls Handled and Scheduled Utilization

4.6.9 Sensitivity Analysis

After determining that the future state wait time is significantly lower than the baseline model, the question that needs to be addressed is how sensitive the future state model is to a shift in event duration, or call volume.

4.6.10 Effect of Increasing Event Duration on Patient Wait Time

In the future state of the Arena model, the average patient wait time is just over one second. This means that in the single queue environment, patient wait time is substantially lower than in any segmented line of business. When decision support was studied in a healthcare contact center by Stacey, Chambers, Jacobsen, & Dunn, in 2008, they found that the event duration for calls increased after decision support implementation. One objective of this study is to understand the relationship between an increased handle time and the wait time that patients will experience. To assess the sensitivity of the future

state model, event durations were increased incrementally, and the resulting wait time was observed. One objective of the contact center was to obtain an average patient wait time less than 30 seconds. The graph below shows the exponential relationship between the average handle time and patient wait time. The purple vertical line in the graph marks where the average patient wait time meets the 30 second mark. To keep the average patient wait time from exceeding 30 seconds, automation in the decision support tool to prevent an increase of event duration beyond 30 seconds is recommended.

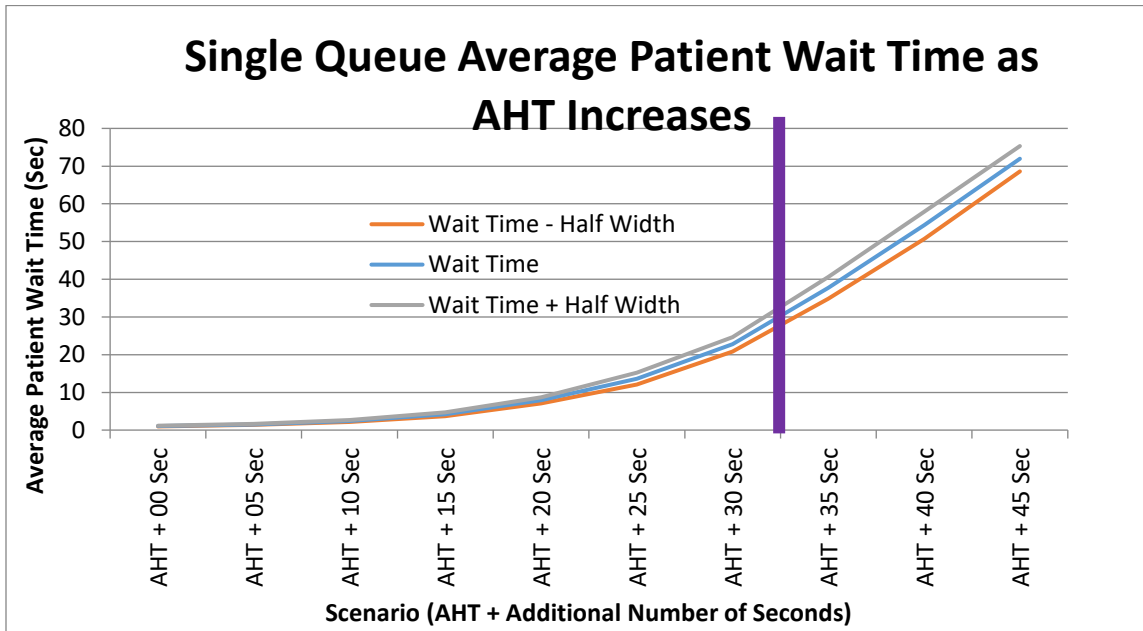

Figure 84: Single Queue Relationship Between Additional Increase to Event Duration and Resulting Patient Wait Time

The graph below shows the continued exponential trend of patient wait time increase as event duration increases.

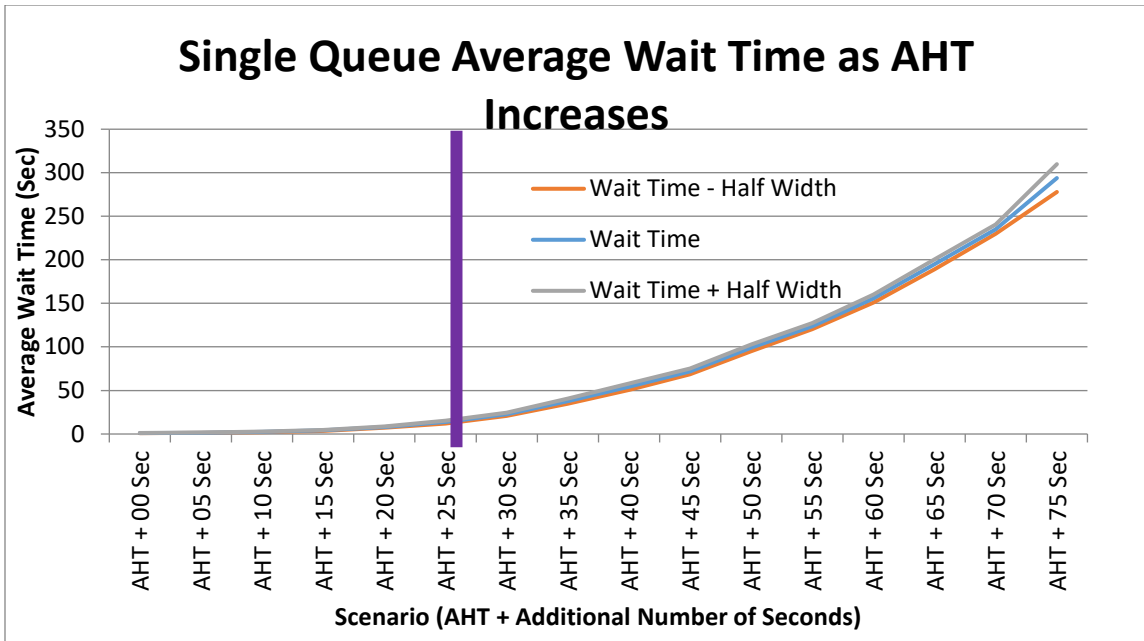

Figure 85: Extended View of the Single Queue Relationship Between Additional Increase to Event Duration and Resulting Patient Wait Time

4.6.11 Effect of Increasing Answered Calls on Patient Wait Time

As patient wait time decreases, the likelihood of an abandoned call being answered increases. One objective of this study was to understand the effects of increased call volume on the future state system. This acted as another way to quantify the capacity of the future state. To perform sensitivity analysis on the future state model with a zero second increase to handle time, the percentage answering of abandoned calls was fluctuated, and the resulting average wait time was recorded. The graph below shows the exponential relationship between the increase in call volume by answering more abandoned calls and the increase to patient wait time. The objective of the contact center is to answer every call within 30 seconds on average. As the call volume increases, the average wait time increases at an exponential rate. In the graph below, an exponential trend line marks the exponential increase in wait time as the call volume increases. As more of the previously abandoned

calls are answered and attended to by CSRs, the average wait time increases. The horizontal purple line marks where the average wait time meets 30 seconds. If the contact center answers 90% of its abandoned calls in the future state, the patients will experience an average wait time of 30 seconds.

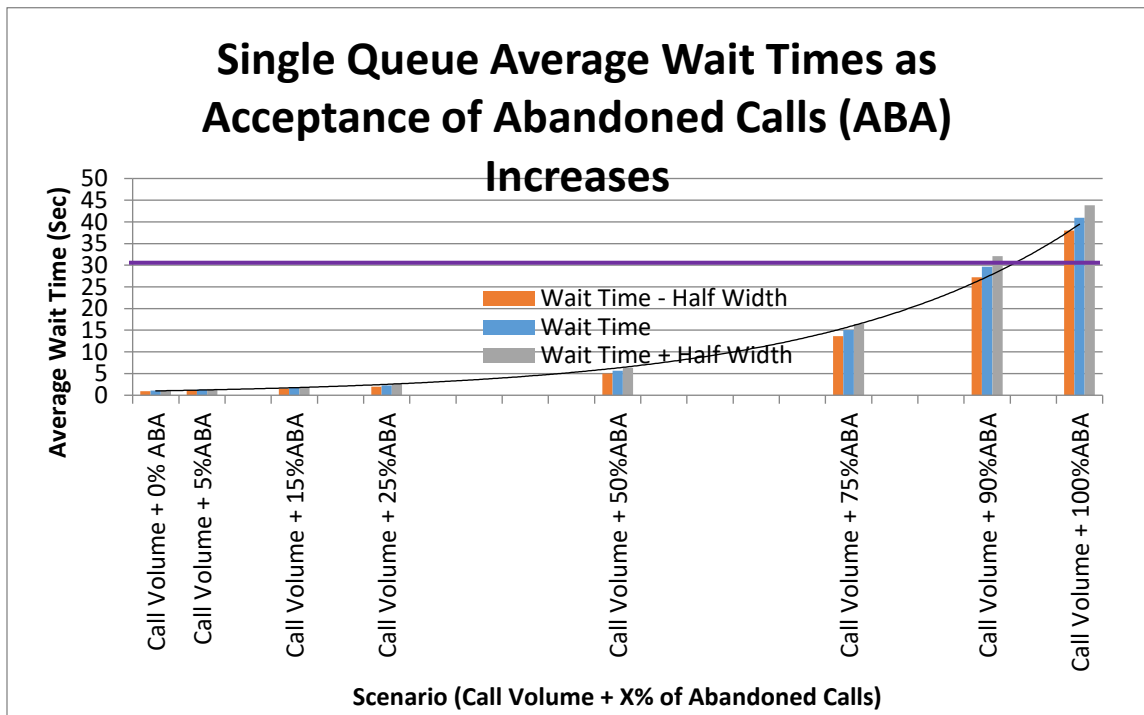

Figure 86: Effects of Increased Acceptance of Abandoned Call Volume on Average Patient Wait Time

4.7 Summary

Through thorough analysis, it is clear that utilizing a decision support tool to develop universal liaisons has many benefits. Benefits include a level loading of CSR utilization, the capacity to handle additional call volume and the capacity to increase handle time. If CSR scheduled utilization is level loaded across all lines of business, burnout-based churn across the contact center will be equal. Churn based on job repetition is less likely because a universal liaison will handle a variety of call types. Churn based on

disengagement will likely decrease because of the feedback button in the decision support tool. CSRs will have the option to effect change in their daily workflows if the change is likely to lead to a higher accuracy, or efficiency within that workflow. Studies suggest that utilizing a decision support tool in a contact center provided higher customer satisfaction, and helped CSRs deliver a higher level of quality service, but also increased the time taken to handle each call. In the future state, 30 seconds can be added to the handle time on all calls, and the wait time for the patient will still be less than 30 seconds. Additionally, if the decision support tool increases the quality, of service provided to patients, calls are more likely to be resolved on the patient's first attempt. This means that less rework will be entered into the system which will drive down the call volume. The reduction in call volume will allow for more abandoned calls to be answered and will allow for CSRs to increase their handle time without seeing a large effect on patient wait time. Additionally, the decision support tool will standardize the service provided to all patients. Currently, the CSRs meet the patient's needs by memorizing the PDF guidelines then searching and reviewing them when the need arises. While the PDF guidelines provide some standardization, they often change. In some cases, this may mean a CSR follows a memorized workflow that is outdated. Using the decision support tool, the CSR will review the most up to date workflow upon initializing the tool on each call. This level of standardization will likely lead to less variation in handle time between CSRs. A lower level of handle time variation between CSR will allow for more accurate staffing which will, again, create further downstream benefits. Additionally, the capacity to handle an increased volume of patient inquiries will allow the contact center to serve a greater number of patients. Since the contact center provides healthcare access and navigability to many

patients, the expanded call volume capacity will allow the contact center to meet the growing needs of the community it serves. The decision support tool could also be enhanced to automate more micro-processes throughout the call. With the automated data collection from the tool, improvement engineers can aim their efforts to affect the largest changes and can combine the collected data with other data sources like customer satisfaction surveys to use data to identify areas for improvement. Future enhancements to the tool that are aimed at reducing the average handle time will have a major impact on CSR Scheduled utilization, patient wait time and can change the capacity of the contact center system. All together, the benefits of utilizing a decision support tool in a healthcare contact center to achieve a universal CSR are plentiful and knowing the sensitivity limits of the future state will help the decision support tool developers plan accordingly.

Chapter 5: Conclusion

This chapter summarizes the research in this thesis. The decision support features identified and developed that will facilitate widespread adoption of the tool are discussed. The simulation findings are also discussed and areas for future work are acknowledged. Section 5.1 summarizes the thesis research. In section 5.2 the significance of the research is discussed. In section 5.3, future research opportunities are outlined and reviewed. Section 5.4 provides a summary of Chapter 5.

5.1 Research Summary

The thesis objective was to develop a decision support tool that allows for collapsing of queues in a healthcare contact center, identify important decision support features that will facilitate widespread adoption, and determine the benefits of using the decision support tool. A five-phase methodology was applied to meet the objectives (Sedgley, 2013). Phase one of the methodology was the definition phase. In this phase, major workflows were outlined and discussed with subject matter experts. In phase two, the identified processes were mapped. Phase three was the standardization phase. One major area within workflows that was not previously standardized was CRM mapping and routing. In this phase, a scenario-based CRM routing database was developed. In phase four, a decision support tool was designed. Four decision support tool facilitators in a healthcare environment are the need for it to be computer-based, automate processes, automatically collect data, and communicate actionable information (Kawamoto, Houlihan, Balas, & Lobach, 2005). While the decision support tool was in development,

these four features were focused on in an attempt to cancel out any increase to event duration that the decision support tool would have and to ensure future widespread adoption. Some features developed that meet these four facilitators were the Spanish language signaling, the Cisco Finesse IVR variable parsing, a process, contact, and feedback collection database, scenario-based CRM scripting and routing capabilities, a CRM database to store and update all CRM routing information, variable development and logic evaluators that could automatically assess variables. These features seamlessly collected data about the call, automated variable extraction and interpretation, created an area for call variable storage that is aimed at enhancing the flow of the call, and deliver relevant and valuable information to the CSR while they perform the call workflows in a standard manner. The decision support tool was designed to facilitate collapsing of contact center queues, by developing a CSR who can answer any patient inquiry. Phase five was the evaluation phase. Time limitations restricted the application of decision support user testing. To determine the effects on the system, a simulation model was developed, verified, and validated. A baseline model and a future state model were designed using Arena simulation software. The baseline model represented the current state of the healthcare contact center. The future state model represented a contact center where all calls are handled in a single queue by universal liaisons using the decision support system. The results determined that the average patient wait time in the current state is over 100 seconds, but the average patient wait time in the future state is less than 2 seconds. The future state design significantly reduces the patient's wait time. Sensitivity analysis was performed to understand how the future state model reacts to increases in event duration and call volume.

5.2 Significance of Research

A significant amount of research has been performed focusing on decision support in a healthcare environment. While some research exists on decision support in a healthcare contact center, the objective of the research is not to consider utilizing the tool to obtain centralization of the contact center staffing model. Some research exists about contact centralization, but this research focuses on standardizing workflows and developing guidelines that act as references for the CSRs navigating through complex calls. This research focuses on using decision support as a tool to centralize a healthcare contact center and identifies features that are necessary for the acceptance and adoption of the decision support tool. This research also expands the definition of contact center centralization to include the centralization of multiple lines of business previously believed to be too different to successfully centralize.

5.3 Future Work

The research performed analyzed the effects of centralizing multiple lines of business in a healthcare contact center that services specialty care and primary care departments within a healthcare system. The centralization can be achieved through the use of scheduling bases and non-scheduling-based decision support tools. In this research, a non-scheduling decision support tool was developed, and important features were outlined and explained in detail. The features identified and developed fit the specific needs of the studied healthcare contact center. Time limitations prevented user testing and limited the decision support tool workflow development to one line of business.

While this thesis answers the major objectives, it also leads to other research questions. First, this decision support tool was developed to meet the needs of the studied healthcare contact center. Other contact centers may require different features, and other forms of process automation may exist. Second, the decision support tool developed was designed to handle non-scheduling workflows. Important scheduling-based decision support tool features have yet to be studied. Third, the impact of contact center centralization was estimated through the use of Arena simulation modeling. Application of decision support to facilitate contact center centralization in a healthcare field can be studied. Fourth, time limitations prevented user testing. User testing and human factors research can accelerate the deployment of a more capable product that more directly meets the needs of the CSRs. Fifth, the simulation model in this thesis focused on a limited number of contact center metrics. Future research could focus on separate metrics or possibly include qualitative metrics.

5.4 Summary

Chapter 5 provides context, and an outline of the researched performed. Research objectives, results, discussion, significance, and ideas for future work are provided. The necessary identified decision support features were examined, and the simulation model results were discussed. While this thesis provides a strong case for decision support use to centralize a healthcare contact center, possibilities for future research were outlined.

References

- Agrawal, D. (2012). "Transforming Trauma Healthcare Delivery In Rural Areas By Use Of An Integrated Call Center." *Journal Of Emergencies, Trauma, And Shock*, 5(1), 7-10.
- Abdullateef, A. O., Mokhtar, S. S. M., & Yusoff, R. Z. (2011). The Mediating Effects Of First Call Resolution On Call Centers' Performance. *Journal of Database Marketing & Customer Strategy Management*, 18(1), 16-30.
- Barthelus, L., Witz, Laura, & Dinauer, Leslie. (2015). *The Call Center Environment: The Effect Of Cognitive Load On Emotional Labor*, Proquest Dissertations And Theses.
- Coleman, A., & Iyawa, G. E. (2015). Improving Health Care Delivery In Rural Communities Through The Use Of Mobile Phones: A Case Study In Windhoek. *International Science and Technology Journal of Namibia*, 6(8).
- Chaudhry, B., Wang, J., Wu, S., Maglione, M., Mojica, W., Roth, E., ... & Shekelle, P. G. (2006). Systematic Review: Impact Of Health Information Technology On Quality, Efficiency, And Costs Of Medical Care. *Annals Of Internal Medicine*, 144(10), 742-752.
- Chokshi, R. (1999). Decision Support For Call Center Management Using Simulation. *Proceedings Of The 31st Conference On Winter Simulation*, 2, 1634-1639.
- Elwyn, G., Scholl, I., Tietbohl, C., Mann, M., Edwards, A. G., Clay, C., ... & Frosch, D. L. (2013). "Many Miles To Go...": A Systematic Review Of The Implementation Of Patient Decision Support Interventions Into Routine Clinical Practice. *BMC Medical Informatics And Decision Making*, 13(2).
- E. S. Corporation, "Patient Engagement: EPIC." (2016).
- Demirkan, H., & Delen, D. (2013). Leveraging The Capabilities Of Service-Oriented Decision Support Systems: Putting Analytics And Big Data In Cloud. *Decision Support Systems*, 55(1), 412-421.
- Kc, D. S. (2013). Does Multitasking Improve Performance? Evidence From The Emergency Department. *Manufacturing & Service Operations Management*, 16(2), 168-183.
- Durand, M. A., Carpenter, L., Dolan, H., Bravo, P., Mann, M., Bunn, F., & Elwyn, G. (2014). Do Interventions Designed To Support Shared Decision-Making Reduce Health Inequalities? A Systematic Review And Meta-Analysis, 9(4).
- Dzuba, R., Roussas, Steve, Dawson, Maurice, Ferreira, Gail, & Kangas, Lisa. (2015). *Exploring The Experiences Of Call Center Employees Regarding Business Scripting*, Proquest Dissertations And Theses. Walden University.

Green, G. I., & Hughes, C. T. (1986). Effects Of Decision Support Systems Training And Cognitive Style On Decision Process Attributes. *Journal Of Management Information Systems*, 3(2), 83-93.

Seref, M. M., Ahuja, R. K., & Winston, W. L. (2007). Developing spreadsheet-based decision support systems. *Dynamic Ideas*.

Hui, J. S. (2017). Call Centre Discourse. *The Routledge Handbook Of Language In The Workplace*.

I. Editors, "Seven Metrics To Watch For Call Center Success." (2011).

Kawamoto, K., Houlihan, C. A., Balas, E. A., & Lobach, D. F. (2005). Improving Clinical Practice Using Clinical Decision Support Systems: A Systematic Review Of Trials To Identify Features Critical To Success. *British Medical Journal*, 330(7494), 765.

Klie, L. (2016). Are Contact Center Metrics Becoming Passé? (Cover Story). *CRM Magazine*, 20(10), 18-21.

Konrad, R., Ficarra, S., Danko, C., Wallace, R., & Archambeault, C. (2017). A Decision-Support Approach For Provider Scheduling In A Patient-Centered Medical Home. *Journal Of Healthcare Management / American College Of Healthcare Executives*, 62(1), 46-59.

Pierre, X., & Tremblay, D. G. (2011). Levels Of Involvement And Retention Of Agents In Call Centres: Improving Well-Being Of Employees For Better Socioeconomic Performance. *Journal Of Management Policy And Practice*, 12(5), 53-71.

Pigman, A., Haan, Perry, Marbury, Raymond, & Whitman, Mary. (2017). Employee Retention In An Organization Call Center, Proquest Dissertations And Theses.

Pow, L., Makrigeorgis, Christos, Kasen, Patsy, & Klein, Jaime. (2017). Contact Center Employee Characteristics Associated With Customer Satisfaction, Proquest Dissertations And Theses.

Rijo, R., Varajão, J., & Gonçalves, R. (2012). Contact Center: Information Systems Design. *Journal Of Intelligent Manufacturing*, 23(3), 497-515.

Roediger, H. L. (1990). Implicit Memory: Retention Without Remembering. *American Psychologist*, 45(9), 1043.

Sedgley, J. (2014). Structured Framework To Guide Contact Center Centralization A Simulation Based Study, Proquest Dissertations And Theses.

Sencer, A., & Basarir Ozel, B. (2013). A Simulation-Based Decision Support System For Workforce Management In Call Centers. *Simulation*, 89(4), 481-497.

Stacey, D., Chambers, S., Jacobsen, M., & Dunn, J. (2008). Overcoming Barriers To Cancer-Helpline Professionals Providing Decision Support For Callers: An Implementation Study.

Stacey, D., O'Connor, A. M., Graham, I. D., & Pomey, M. P. (2006). Randomized Controlled Trial Of The Effectiveness Of An Intervention To Implement Evidence-Based Patient Decision Support In A Nursing Call Centre. *Journal Of Telemedicine And Telecare*, 12(8), 410-415.

Stamps, C., Claesson, Ann, Mcclendon, Cristie, & Wieters, Lori. (2014). Exploring Retention Of United States-Based Inbound Call Center Employees: A Case Study, Proquest Dissertations And Theses.

SQUIRE Guidelines, IHI. (2018). www.ihl.org/resources/pages/otherwebsites/squireguidelines.aspx. Accessed 4 Feb. 2018.

T. R. Eng, A. Maxfield, K. Patrick, M. J. Deering, S. C. Ratzan, And D. H. Gustafson. 1998 Access To Health Information And Support: A Public Highway Or A Private Road?. *Journal of the American Medical Association*, 280 (15), 1371–1375.

Legleitner, R., O'Donnell, Lorraine, Berg, Marla, & Lang, Lucille. (2015). The Evaluation And Implementation Of A Strategy To Improve Entry-Level Employee Retention In A Utility Call Center, Proquest Dissertations And Theses.

Marcoux, G. (2012). The Work Of Customer Service Representatives In A Canadian Call Center: Role Distance And Management Of Emotions At Work. *Business Studies Journal*, 4(2).

Marx, R., Vasconcellos, L. H. R., & Lara, F. F. D. (2015). Can The Call Centre Contribute To Innovation? A Multiple Case Study In Service Companies. *International Journal Of Business Excellence*, 8(3), 251-267.

Meric-Bernstam, F., Johnson, A., Holla, V., Bailey, A. M., Brusco, L., Chen, K., ... & Davies, M. A. (2015). A Decision Support Framework For Genomically Informed Investigational Cancer Therapy. *Journal Of The National Cancer Institute*, 107(7).

Murdoch, T. B., & Detsky, A. S. (2013). The Inevitable Application Of Big Data To Health Care. *Journal of the American Medical Association*, 309(13), 1351-1352.

Nardin, Ted. (2006). Hiring And Training For The Call Center: Developing The "Universal Agent" And Beyond.(Workforce Optimization). *Customer Interaction Solutions*, 24(9), 46-49.

Weiss, Brown, & Whaley. (2013). Call Center Employee Adherence To Customer Service Scripting. *Journal Of The Academy Of Nutrition And Dietetics*, 113(9).

Welsch, S., Campana, Kristie, Mahoney, Chris, & Perez, Lisa. (2016). Mood And Engagement Contagion In A Call Center Environment, Proquest Dissertations And Theses.

Yonyx, . (N.D.). In Decision Trees For CRM & Web. Retrieved From <http://corp.yonyx.com/>

Zak, E. (2014). Including Smartphone End User Apps In The Context Of The Company Contact Center.

Zingtree, . (N.D.). In Create Interactive Decision Trees. Retrieved From <https://zingtree.com/>