

6-1-2013

# Evaluation and Optimization of Bioretention Design for Nitrogen and Phosphorus Removal

Robert M. Roseen  
*Geosyntec Consultants*

Robin M. Stone  
*University of New Hampshire*

Follow this and additional works at: <https://scholars.unh.edu/stormwater>

---

## Recommended Citation

Roseen, Robert M. and Stone, Robin M., "Evaluation and Optimization of Bioretention Design for Nitrogen and Phosphorus Removal" (2013). *UNH Stormwater Center*. 36.  
<https://scholars.unh.edu/stormwater/36>

This Report is brought to you for free and open access by the Research Institutes, Centers and Programs at University of New Hampshire Scholars' Repository. It has been accepted for inclusion in UNH Stormwater Center by an authorized administrator of University of New Hampshire Scholars' Repository. For more information, please contact [nicole.hentz@unh.edu](mailto:nicole.hentz@unh.edu).

# Evaluation and Optimization of Bioretention Design for Nitrogen and Phosphorus Removal

---



*Prepared and Conducted by*

*Robert M. Roseen, PhD, PE, D.WRE  
Associate, Geosyntec Consultants  
Principal Investigator, Adjunct Professor,  
UNHSC  
[roseen@geosyntec.com](mailto:roseen@geosyntec.com)*

*Robin M. Stone, M.S., EIT  
Graduate Research Assistant  
UNH Stormwater Center  
[stone.robinm@gmail.com](mailto:stone.robinm@gmail.com)*

*Prepared with Support from U.S. Environmental Protection Agency Region 1 TMDL Program, Town of Durham, Seattle Public Utilities  
June 2013*



## **ACKNOWLEDGEMENTS**

This study was conducted under funding from the USEPA Region 1 TMDL Program. We extend our sincere appreciation to the Town of Durham for their partnership. The strong municipal partnership and cost sharing was essential to the project success and site selection, and long-term ownership and maintenance.

### **Project Sponsor**

US Environmental Protection Agency

### **Project Team**

#### ***UNH Stormwater Center***

Robert Roseen, PhD, PE, D.WRE (Project Lead)

Robin Stone, MS (Project Researcher)

Alison Watts, PhD, PG (Research Committee)

Robin Collins, PhD, PE (Research Committee)

James Houle, CPSWQ

Timothy Puls, EIT

Thomas Ballesterio, PhD, PE, PG, PH, CGWP

#### ***Town of Durham***

David Cedarholm

Michael Lynch

Todd Selig

Robin Mower

Diana Carroll

### **EPA Project Officers**

Steven Winnett

Stephen Silva

# TABLE OF CONTENTS

<b>ACKNOWLEDGEMENTS</b> .....	<b>IV</b>
<b>LIST OF FIGURES</b> .....	<b>3</b>
<b>LIST OF TABLES</b> .....	<b>5</b>
<b>LIST OF EQUATIONS</b> .....	<b>7</b>
<b>TASK 1: LABORATORY AND FIELD STUDIES</b> .....	<b>8</b>
<b>EXECUTIVE SUMMARY</b> .....	<b>8</b>
<b>INTRODUCTION</b> .....	<b>8</b>
BIORETENTION SOIL MIX DESIGN .....	2
BIORETENTION STRUCTURAL CONFIGURATION DESIGN .....	3
STUDY AREA .....	6
SUMMARY OF PROJECT OBJECTIVES.....	7
<b>LITERATURE REVIEW</b> .....	<b>8</b>
BIORETENTION DATABASE FIELD SYSTEM NUTRIENT PERFORMANCE .....	8
COMPOST AND LEACHING POTENTIAL.....	11
ISOTHERM MODELS FOR P SORPTION .....	12
CORRELATING AL <sub>OX</sub> AND FE <sub>OX</sub> TO P SORPTION.....	13
COMPETING IONS, ALUMINUM LEACHING POTENTIAL, AND PH .....	13
IMPACT OF WTR AGING .....	14
WTR AND NITROGEN .....	14
EXTRAPOLATING ISOTHERM DATA TO FIELD APPLICATION .....	14
<b>METHODS AND MATERIALS</b> .....	<b>15</b>
EXPERIMENTAL DESIGN .....	15
BSM MATERIALS .....	17
ANALYTICAL PROCEDURES .....	19
BATCH EQUILIBRIUM STUDIES .....	19
<i>Kinetics Studies</i> .....	20
<i>Isotherm Studies</i> .....	20
COLUMN STUDIES.....	20
<i>Permeameter Tests</i> .....	20
<i>Column Setup</i> .....	21
<i>Column Sampling Regimens</i> .....	21
<i>Hydraulic and Nutrient Loading</i> .....	22
<i>Column Contents</i> .....	23
DATA ANALYSIS METHODS .....	25
<i>Isotherm Model Fitting</i> .....	25
<i>Statistical Analysis of Isotherm Models</i> .....	26
<i>Model Verification</i> .....	27
DESIGN OF A BIORETENTION-GRAVEL WETLAND HYBRID.....	29
<b>RESULTS AND DISCUSSION</b> .....	<b>32</b>
SOIL TEST RESULTS .....	32
BATCH EQUILIBRIUM TEST RESULTS.....	35
<i>Kinetics Studies</i> .....	35
<i>Adsorption Isotherm Studies</i> .....	37
<i>Isotherm Model Statistical Analysis</i> .....	49
COLUMN STUDY RESULTS .....	53
<i>Column Media Infiltration Rates and Contact Times</i> .....	53
<i>Column Water Quality Performance</i> .....	56

<i>Annual Nutrient Loads</i> .....	57
<i>Empty Bed Contact Time effect on BSM performance</i> .....	60
<i>Impact of WTR Processing on Column Performance</i> .....	62
<i>Filter Media Lifecycle Analysis</i> .....	64
<b>SUMMARY OF LABORATORY RESULTS</b> .....	<b>68</b>
<b>FIELD BIORETENTION MONITORING RESULTS</b> .....	<b>69</b>
<i>Internal Storage Reservoir Performance for Nitrogen Removal</i> .....	73
<i>Performance of Systems for Phosphorus, TSS, and Zinc</i> .....	76
<i>Impact of Influent Concentration on Performance</i> .....	78
<i>Treatment Effects on Nutrients</i> .....	84
<b>SUMMARY OF FIELD RESULTS</b> .....	<b>88</b>
<b>CONCLUSIONS AND FUTURE RESEARCH</b> .....	<b>89</b>
<b>CONCLUSIONS</b> .....	<b>89</b>
<i>Optimization of Phosphorus Removal</i> .....	89
<i>Optimization of Nitrogen Removal</i> .....	90
<i>BSM and ISR Design Recommendations for Optimized Nutrient Removal</i> .....	90
<b>FUTURE RESEARCH</b> .....	<b>91</b>
<b>REFERENCES</b> .....	<b>93</b>
<b>APPENDIX A</b> .....	<b>99</b>
ANALYTICAL METHODS .....	99
SOIL REPORTS .....	99
BSM COMPOSITION .....	99
<b>APPENDIX B</b> .....	<b>108</b>
BATCH EQUILIBRIUM STUDIES DATA .....	108
<b>APPENDIX C</b> .....	<b>121</b>
COLUMN STUDIES HYDRAULICS DATA.....	121
COLUMN STUDIES WATER QUALITY DATA .....	121
<b>APPENDIX D: DURHAM BIORETENTION DESIGN DRAWINGS</b> .....	<b>130</b>
<b>APPENDIX E</b> .....	<b>144</b>
BIO-5 CELL 2 MONITORING DATA.....	144
BIO-5 CELL 1 MONITORING DATA.....	144
BIO-5 CELL 1 TIME SERIES FIGURES.....	144

## LIST OF FIGURES

Figure 1. Bioretention Schematic .....	4
Figure 2. Gravel Wetland Schematic.....	5
Figure 3. Aerial View of Study Area.....	6
Figure 4. Box-and-Whisker Plots for Total Phosphorus from the SPU Bioretention Database. ..	9
Figure 5. Box-and-Whisker Plots for Orthophosphate from the SPU Bioretention Database.....	9
Figure 6. Cumulative Frequency Functions of Total Phosphorus and Orthophosphate Removal Efficiencies in the SPU Bioretention Database. ....	10
Figure 7. Box-and-Whisker Plots for Total Nitrogen from the Bioretention Database. ....	11
Figure 8. Box-and-Whisker Plots for Nitrate from the Bioretention Database.....	11
Figure 9. WTR Lagoon at the Durham Drinking Water Treatment Plant.....	18
Figure 10. Far side of WTR lagoon at Durham Drinking Water Treatment Plant. ....	18
Figure 11. Layout of Durham Bio-5 Bioretention Cells.....	30
Figure 12. Long Section of Durham Bio-5 Bioretention Cells.....	30
Figure 13. Cross-Section of Durham Bio-5 Bioretention Cells.....	31
Figure 14. BSM Composition on a volume basis.....	34
Figure 15. BSM Composition on a dry mass basis.....	35
Figure 16. Kinetics Study Results. ....	36
Figure 17. Adsorption Isotherm Data for BSM Constituents. ....	37
Figure 18. Adsorption Isotherm Data for BSMs.....	38
Figure 19. Langmuir Isotherm Model for Constituents.....	40
Figure 20. Freundlich Isotherm Model for Constituents.....	41
Figure 21. Langmuir Isotherm Model for BSMs .....	41
Figure 22. Freundlich Isotherm Model for BSMs .....	42
Figure 23. Isotherm Model Assessment: Linear Regression of Observed vs. Modeled $q$ (mg/g).52	
Figure 24. Infiltration Rates of filter media (BSMs) used in each column study phase and permeameter tests. ....	55
Figure 25. Phases 1 and 2 Column Removal Efficiencies based on annual nutrient loads of 43 mg OP/ft <sup>2</sup> .....	59
Figure 26. Phase 3 Column Removal Efficiencies based on annual nutrient loads of 43 mg OP/ft <sup>2</sup> .....	60
Figure 27. Column Performance for OP Removal from all columns with 10% WTR from phases 1-3. ....	63
Figure 28. Cumulative Distribution of orthophosphate concentrations in phase 3 column study. ....	64
Figure 29. Bio-5 in Durham, NH immediately after completion (a) and during the first storm (b), Cell 2 in the foreground in each. Photos by Viktor Hlas. ....	70
Figure 30. Time Series Water Quality Data from Bio-5 Cell 2 for contaminants (a) Total Suspended Sediments, (b) Total Nitrogen, (c) Nitrate, (d) Total Phosphorus, (e) Orthophosphate, and (f) Total Zinc. ....	72
Figure 31. Box-and-Whisker Plots for 4 UNHSC vegetated systems' performance for (a) Total Nitrogen and (b) Nitrate. ....	75
Figure 32. Box-and-Whisker Plots for 4 UNHSC vegetated systems' performance for (a) Total Phosphorus, (b) Orthophosphate, (c) Total Suspended Solids, and (d) Total Zinc.....	78

*Figure 33. Contaminant Removals by 4 UNHSC vegetated stormwater treatment systems. .... 80*  
*Figure 34. Influent Concentration distribution for 4 vegetated systems monitored by UNHSC. 81*  
*Figure 35. Cumulative distribution functions for 4 UNHSC vegetated systems..... 83*  
*Figure 36. Treatment Effect Plot on OP for 4 UNH systems..... 84*  
*Figure 37. Treatment Effect Plot on TP for 4 UNH systems. .... 85*  
*Figure 38. Treatment Effect Plot on TN for 4 UNH systems..... 86*  
*Figure 39. Time Series Water Quality Data for Bio-5 Cell 1..... 152*

## LIST OF TABLES

Table 1. Summary of Experiments. ....	16
Table 2. Harvested Stormwater Runoff used as base solution for laboratory experiments. ....	16
Table 3. Composition of Bioretention Soil Mixes for Column Studies. ....	24
Table 4. Materials Characterization.....	33
Table 5. Mass % Composition of BSMs.....	39
Table 6. Langmuir Isotherm Model Parameters.....	44
Table 7. Freundlich Isotherm Model Parameters.....	45
Table 8. Langmuir P sorption capacity, BSM ordered by the measured $q_{1,0}$ . ....	46
Table 9. Freundlich P sorption capacity, BSM ordered by the measured $q_{1,0}$ . ....	47
Table 10. Table of $P_{max}$ values of project materials and others from literature.....	48
Table 11. Statistical Model Assessment Measures of observed values and values modeled by Langmuir and Freundlich isotherm models for (a) soil mix components and (b) BSMs.....	50
Table 12. Infiltration Rates and Empty Bed Contact Times (EBCT) of all column media. ....	56
Table 13. Summary Statistics of all column study phases. ....	61
Table 14. Capacity of soil mixes based on Langmuir modeled mass adsorption capacity of columns ( $m_p$ ) and actual mass adsorption( $m_a$ ) during column study phase 3.....	66
Table 15. Contributions of each component to the PSC of bioretention soil mixes. ....	67
Table 16. Summary Statistics of Dissolved Oxygen concentrations in Bio-5 Cell 2 catchbasin for four summer 2012 storms. ....	74
Table 17. Summary Statistics of pH in Bio-5 Cell 2 catchbasin for four winter and four summer storms.....	76
Table 18. Summary Statistics of UNHSC vegetated systems' performance for removal of TSS, Zinc, TN, Nitrate, TP, and Orthophosphate.....	87
Table 19. Absolute Resource Associates Laboratory analytical methods and expected detection limits for each analyte.....	100
Table 20. Analytical Services Laboratory analytical methods and expected performance data for each analyte. ....	101
Table 21. Biosolids and Septage Spreading Soil Reports.....	103
Table 22. Compost Soil Reports Part 1. ....	104
Table 23. Compost Soil Reports Part 2. ....	105
Table 0-6. Sum of Cation Equivalents. ....	105
Table 25. BSM Composition(volumetric).....	107
Table 26. BSM Composition (dry mass basis).....	107
Table 27. Kinetics Study 1 4/6-4/8/2011.....	109
Table 28. Kinetics Study 9/20-9/23/2011.....	111
Table 29. Kinetics Study 1/11-1/20/12.....	112
Table 30. Component Isotherm Studies(Grayed out rows indicate data points removed from analyses after QC) . ....	113
Table 31. Bioretention Soil Mix (BSM) Isotherm Studies(Grayed out rows indicate data points removed from analyses after QC).....	117
Table 32. Infiltration Rates (in/hr) from phase 1 column studies.....	122
Table 33. Infiltration Rates (in/hr) from phase 2 column studies.....	122
Table 34. Infiltration Rates (in/hr) from phase 3 column studies.....	123
Table 35. Empty Bed Contact Times (minutes) from phase 1 column studies.....	123
Table 36. Empty Bed Contact Times (minutes) from phase 2 column studies.....	124



<i>Table 37. Empty Bed Contact Times (minutes) from phase 3column studies, as determined from total run times and total effluent volumes for each event. ....</i>	<i>124</i>
<i>Table 38. Calculations of Annual OP Load.....</i>	<i>125</i>
<i>Table 39. Calculations of OP Loads.....</i>	<i>125</i>
<i>Table 40. Phase 1 Column Study OP Concentration Data.....</i>	<i>125</i>
<i>Table 41. Phase 1 Column Study Removal Efficiencies. ....</i>	<i>126</i>
<i>Table 42. Phase 2 Column Study OP Concentration Data.....</i>	<i>127</i>
<i>Table 43. Phase 2 Column Study OP Removal Efficiencies. ....</i>	<i>127</i>
<i>Table 44. Phase 3 Column Study OP Concentration Data.....</i>	<i>128</i>
<i>Table 45. Phase 3 Column Study OP Removal Efficiencies. ....</i>	<i>129</i>
<i>Table 46. Plants in initial planting of Bio-5. ....</i>	<i>131</i>
<i>Table 47. Schedule. ....</i>	<i>131</i>
<i>Table 48. Bio-5 Cell 2 Data for all monitored storms.....</i>	<i>145</i>
<i>Table 49. Bio-5 Cell 1 Data for all monitored storms.....</i>	<i>149</i>

## LIST OF EQUATIONS

Equation 1. Phosphate Adsorption .....	3
Equation 2. Nitrification .....	4
Equation 3. Nitrification .....	4
Equation 4. Denitrification .....	4
Equation 5. Column Infiltration Rate Estimation .....	22
Equation 6. Empty Bed Contact Time .....	22
Equation 7. Observed Adsorbent-Phase Concentration .....	25
Equation 8. Langmuir-Modeled Adsorbent-Phase Concentration .....	25
Equation 9. Linearized Langmuir Equation .....	26
Equation 10. Freundlich-Predicted Adsorbent-Phase Concentration .....	26
Equation 11. Linearized Freundlich Equation .....	26
Equation 12. Mean Absolute Error .....	27
Equation 13. Root Mean Square Error .....	27
Equation 14. Index of Agreement .....	27
Equation 15. Nash-Sutcliffe Efficiency .....	27
Equation 16. Removal Efficiency .....	27
Equation 17. Efficiency Ratio .....	28
Equation 18. Cunnane Plotting Position .....	28
Equation 19. Oxalate Ratio .....	32
Equation 20. Calculated Adsorption Rate .....	45
Equation 21. Empty Bed Contact Time .....	54
Equation 22. Removal Efficiency .....	57
Equation 23. Annual OP Loads .....	58
Equation 24. Mass Adsorbed in Columns .....	64
Equation 25. Predicted Mass Adsorption Capacity .....	65

# Final Report on Evaluation and Optimization of Bioretention Design for Nitrogen and Phosphorus Removal

---

## **TASK 1: LABORATORY AND FIELD STUDIES**

### **EXECUTIVE SUMMARY**

Laboratory and field investigations were conducted into the performance of modified bioretention designs, optimized for reduction of nutrient loads from stormwater runoff into sensitive water bodies, such as southeast New Hampshire's Great Bay. Bioretention design characteristics of particular interest were filter media composition and structural configuration. Dissolved phosphorus may be adsorbed to aluminum (hydr)oxide surfaces, such as those present in drinking water treatment residuals (WTR), in filter media. A series of aerobic and anaerobic zones in treatment systems allows for nitrogen transformations into nitrogen gas, removing it from water. A filter media admixture of raw WTR at low solids content (5-10% solids) effectively removed orthophosphate in laboratory tests when included at 10-15% of the bioretention soil mix by volume (90-99% median removal efficiencies). WTR processed to increase solids content to 34% demonstrated consistently higher removal efficiencies (>99%).

This study introduces an innovative bioretention design with WTR admixture filter media and internal storage reservoir to optimize both phosphorus and nitrogen removal. A bioretention system constructed in the town of Durham, NH in summer 2011 and monitored from fall 2011 to fall 2012 includes a bioretention soil mix with raw WTR admixture (~10% solids) and a structural design modeled after the UNHSC subsurface gravel wetland design specifications, a system that has demonstrated excellent nitrogen removal through an internal anaerobic storage reservoir. Orthophosphate, the most bioavailable form of phosphorus, was generally reduced in this system, with median removal efficiency of 20% and effluent concentrations consistently below 0.02 mg/L. A median nitrate removal efficiency of 60% showed substantial improvement over the median 14% removal efficiency by systems reported in the literature based bioretention database for Seattle Public Utilities. The innovative Durham bioretention system also achieved median removal efficiencies of 55% and 36% for total phosphorus and total nitrogen, respectively.

### **INTRODUCTION**

Excess nutrient loading to surface waters accelerates the process of eutrophication, degrading water bodies for habitat, drinking water, recreation and other uses. Stormwater runoff is a contributor of nutrients to surface water bodies, particularly in areas of urban development with a large amount of impervious cover. The 2009 State of the Estuaries Report for the Piscataqua region of New Hampshire identifies stormwater runoff as a major contributor to the 42% increase in nitrogen load to Great Bay from 2004 to 2009. Nitrogen is seen as the growth

limiting nutrient in saltwater bodies (Howarth and Marino 2006), such as the sensitive New Hampshire estuaries, while phosphorus is limiting in freshwater (Schindler et al. 2008). Some argue, however, that it is important to manage both nitrogen and phosphorus loads to all water bodies to avoid accelerating the process of eutrophication (Carpenter et al. 1998; Conley et al. 2009). Plant material and excess fertilizer often contribute to the nutrient load in runoff, as well as atmospheric deposition of nitrogen from fossil fuel emissions. Conley et al. (2009) emphasize the necessity of balancing both nitrogen and phosphorus loads to avoid transporting dead zones downstream.

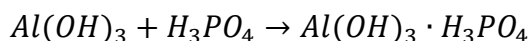
Optimized bioretention systems are a way to potentially reduce the nutrient loads from stormwater runoff to surface waters in order to achieve the balance needed to slow the process of eutrophication. Bioretention systems have become popular in recent years as a small footprint, low maintenance Low Impact Development (LID) option, capable of reducing negative hydrologic and water quality effects of land development. While bioretention systems tend to perform very well with regards to removal of suspended solids, including particulate phosphorus, through sedimentation and filtration, as well as adsorption of heavy metals, adsorption of dissolved phosphorus is associated with the presence of amorphous aluminum and iron oxides, which are highly variable in bioretention soils (Davis et al. 2010). Ammonia is also adsorbed on filtration media, but is often subject to biotransformations, necessitating intervention with regard to microbiological processes for the sake of nitrogen removal (Davis et al. 2010). The aerobic process of nitrification, transforming the trapped ammonia ( $\text{NH}_3$ ) to nitrite ( $\text{NO}_2$ ) and nitrate ( $\text{NO}_3$ ), often occurs between rainfall events in bioretention systems (Davis et al. 2010). Without also designing for an anoxic zone, in which denitrification can occur, bioretention systems may export significant amounts of nitrate (Davis et al. 2010). Davis et al. (2010) call for the exploration of supplementing phosphorus sorption capacity of bioretention soils and utilizing the potential for denitrification in the structural configuration of bioretention systems.

This study examines bioretention soil mixes (BSMs) and structural configurations to optimize the removal of nitrogen and phosphorus from runoff. Assuming that vegetation will provide important uptake of nutrients (Henderson et al. 2007), this study seeks to develop a bioretention soil mix designed to optimize phosphorus removal through filtration and adsorption while also supporting plant growth, and a bioretention structural design which includes an internal storage reservoir and increased horizontal flow path length to promote the process of denitrification.

## **Bioretention Soil Mix Design**

The goal of this study with regards to bioretention soil mix (BSM) design is to predict performance of BSMs with water treatment residuals as an admixture. Drinking water treatment plants frequently add coagulants to induce the removal of color, taste, and odor from source water (Crittenden et al. 2005). Common coagulants include aluminum sulfate ( $\text{Al}_2(\text{SO}_4)_3 \cdot 14\text{H}_2\text{O}$ , commonly known as alum), polyaluminum chloride ( $\text{Al}_a(\text{OH})_b(\text{Cl})_c(\text{SO}_4)_d$ , also referred to as PACl), and ferric salts (Crittenden et al. 2005). The Durham Drinking Water Treatment Plant uses polyaluminum chloride (PACl) as a coagulant for drinking water treatment. The focus of this study in experiments as well as literature review was aluminum-based water treatment residuals, i.e., those resulting from treatment with either PACl or alum. Class jar tests performed at UNH and the subsequent ANOVA analysis indicated that the difference in performance of alum and PACl as coagulants was not statistically significant (unpublished data, Robin Stone).

The sludge that settles after the coagulation/flocculation process contains amorphous aluminum and iron (hydr)oxides, which are highly reactive with dissolved phosphorus and have a large surface area for adsorption to occur (Lucas and Greenway 2011a; Makris et al. 2004). According to Makris et al. (2004), WTRs contain internal micropores in which diffusion occurs. An elevated activation energy of desorption within the micropores immobilizes sorbed P, increasing its stability. Alum has been used to successfully reduce phosphorus runoff from poultry litter in previous studies (Moore et al. 1999). The adsorption equation is given as:



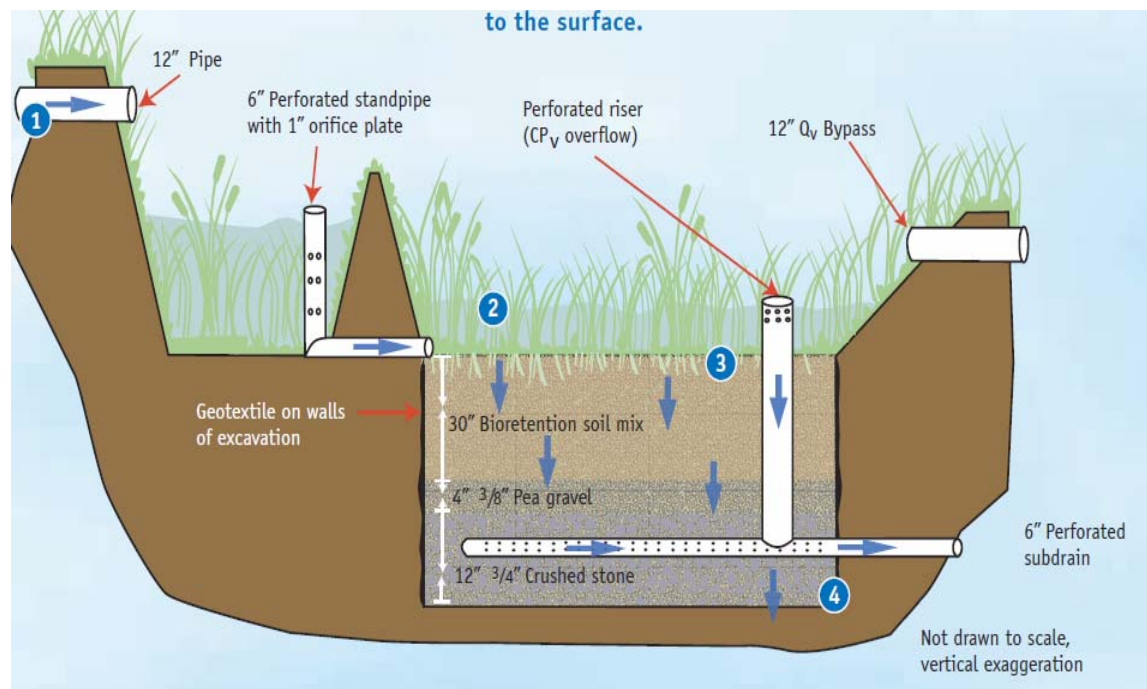
**Equation 1. Phosphate Adsorption**

The product of this equation is an amorphous aluminum phosphate compound, which is transformed over time into more stable crystalline mineral, such as variscite,  $AlPO_4 \cdot 2H_2O$ , or wavellite,  $Al_3(PO_4)_2(OH)_3 \cdot 5H_2O$  (Moore et al. 1999). Studies of phosphate sorption-desorption behavior in acidic soils by Sanyal et al. (1993) demonstrated the hysteresis of P sorption. Desorption experiments actually had higher levels of sorbed P than sorption experiments (Sanyal et al. 1993). Similar results for the immobilization of dissolved P may be expected from WTR, due to the similar chemistry of alum and PACl, which is present in WTR from Durham.

The Langmuir and Freundlich isotherm models are frequently used in linearized forms to model the adsorption process and provide information about the adsorption capacity of a material. These models were used to calculate the phosphorus adsorption capacity of WTRs, which may then be used to predict the performance of WTR in a bioretention soil mix. Studies have found the Langmuir model to be useful for modeling phosphorus adsorption by WTR (Dayton and Basta 2005; Moazed et al. 2010; Novak and Watts 2004).

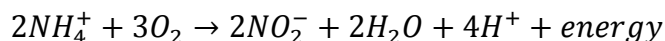
## **Bioretention Structural Configuration Design**

Bioretention systems are typically constructed with an underdrain in a crushed stone layer over which lies 18-30 inches of BSM (filter media), in which native shrubs or grasses are planted. A perforated riser serves as an overflow drain and is raised above the top of the BSM by 4-12 inches, depending on the design maximum ponding depth. Figure 1 illustrates a bioretention system with a forebay for pretreatment. As previously mentioned, bioretention systems tend to perform well for removal of suspended solids, metals, and hydrocarbons. Removal efficiencies reported by the UNH Stormwater Center (UNHSC) in its 2012 Biennial Report are 90% for TSS (total suspended solids), 78% for metals and 82% for TPH-D (total petroleum hydrocarbons) (UNH Stormwater Center et al. 2012). The reported performance for DIN (dissolved inorganic nitrogen) and TP (total phosphorus) was moderate at best, coming in at 32% removal of DIN in summer, and just over 12% annual removal of TP (UNH Stormwater Center et al. 2012). While phosphorus may be immobilized by simple filtration and adsorption processes, the nitrogen cycle is more complex, involving many different forms of nitrogen and depending on microbiological processes (Mitsch and Gosselink 2000).

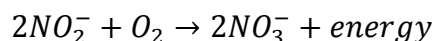


**Figure 1. Bioretention Schematic**

The ability of natural wetlands to remove nitrogen from the lithosphere and hydrosphere has been harnessed in constructed subsurface gravel wetland systems, which demonstrated 75% annual median DIN removal efficiency at the UNHSC West Edge Facility from 2004 to 2010 (UNH Stormwater Center et al. 2012). For the necessary transformations to occur, an aerobic zone must precede an anaerobic zone in the travel path. The schematic of the UNHSC subsurface gravel wetland in Figure 2 illustrates each of these zones and the nitrogen transformations that occur in each. Nitrogen mineralization converts organically bound nitrogen to ammonium ( $\text{NH}_4^+$ ) and can occur in either aerobic or anaerobic conditions. Ammonium ions may be transformed to ammonia and released to the atmosphere or adsorbed to the soil, but they may also undergo oxidation through nitrification (Mitsch and Gosselink 2000). Nitrification is a two step process involving bacteria *Nitrosomonas* and *Nitrobacter*, which converts ammonium to nitrite then nitrate by the reactions below (Mitsch and Gosselink 2000):

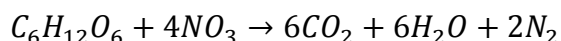


**Equation 2. Nitrification**



**Equation 3. Nitrification**

Nitrate ( $\text{NO}_3^-$ ) is the next terminal electron acceptor after oxygen has been consumed; thus under anaerobic conditions, the denitrification process converts nitrate to nitrogen gas to be released to the atmosphere (Mitsch and Gosselink 2000):



**Equation 4. Denitrification**

The anaerobic zone is constructed in the subsurface gravel wetland by the installation of an elevated outlet above the gravel layer, creating an internal storage reservoir. Native soil below the gravel layer is compacted to discourage infiltration so that the gravel layer remains saturated and becomes anaerobic due to bacterial activity. The several pathways for nitrogen retention are typically slower processes than those which remove other contaminants. Some of these occur between, rather than during, rain events in a system. Gravel wetland systems tend to have large footprints due to the need for an extended travel path. UNHSC design specifications recommend a minimum horizontal flow path length of 30 feet (UNH Stormwater Center et al. 2012). One study concluded that nitrogen retention is a rate-dependent process, based on a study of outlet controlled bioretention mesocosms, which retained more than double the nitrogen oxides ( $\text{NO}_x$ ) and total nitrogen than their free-flowing counterparts (Lucas and Greenway 2011b). By combining elements of each of these systems (filter media from the bioretention system and an internal storage reservoir from the gravel wetland), removal of both nitrogen and phosphorus should be improved over typical bioretention designs.

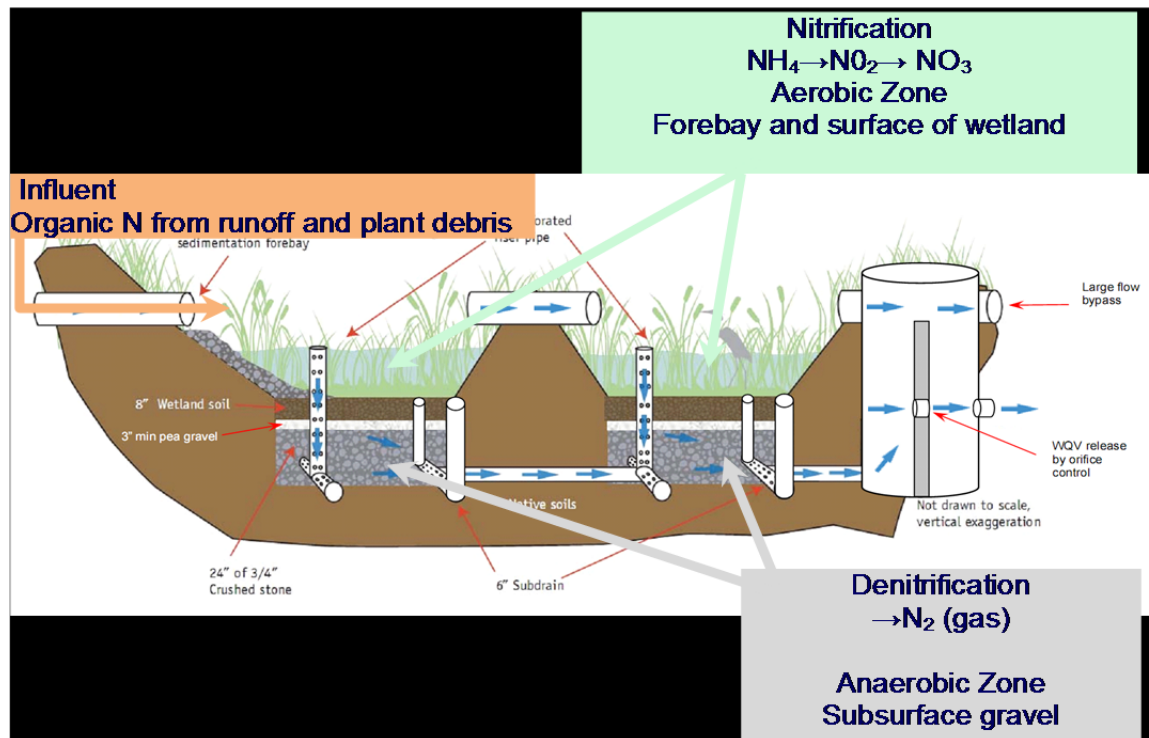


Figure 2. Gravel Wetland Schematic

## Study Area

The study area chosen for implementing this new design is in a municipal lot in downtown Durham, NH. Two side-by-side systems were constructed in summer 2011 in a heavily trafficked parking lot, leased from the University of New Hampshire by the town of Durham. Construction was a joint venture between the UNH Stormwater Center, EPA Region 1, and the Town of Durham. Figure 3 shows an aerial view of the proposed site location and the surveyed drainage areas to the two systems, named Cell 1 and Cell 2. Drainage area 1 drains to Cell 1, while drainage areas 2 and 3 drain to Cell 2. Each system receives runoff from rooftop as well as asphalt parking lot and parking spaces.

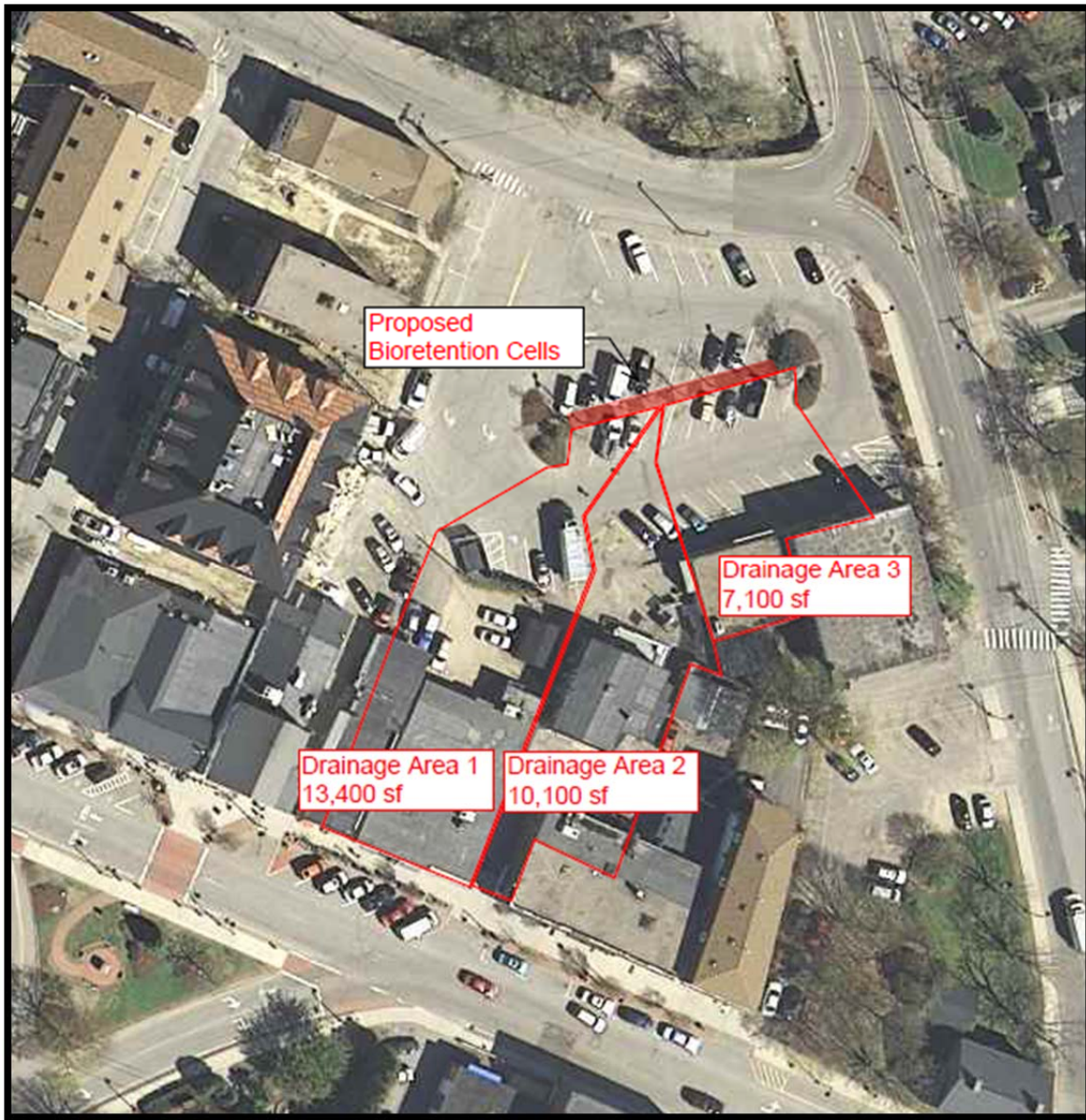


Figure 3. Aerial View of Study Area



## **Summary of Project Objectives**

The objective of this study was to optimize bioretention filter media and structural design for nutrient removal from stormwater runoff. The particular goals included performance assessments of: 1) aluminum-based water treatment residuals as filter media amendments to enhance phosphorus adsorption, and 2) internal storage reservoir design to promote denitrification in bioretention systems. Water treatment residuals (WTR) were evaluated in both raw and processed forms, alongside other filter media constituents. Internal storage reservoir design characteristics of note included the volume of the reservoir and the length of the horizontal flow path. The flow path length directly affects the time water spends in the anaerobic zone where denitrification may occur.

The experimental work for this project included laboratory and field phases, with the laboratory phase focusing on filter media design and the field phase implementing filter media and structural designs for optimization of phosphorus and nitrogen removal. Filter media selection involved assessment of phosphorus sorption capacities of materials based on soil tests, batch equilibrium studies, and column studies performed in the laboratory phase. Finally, filter media and structural designs hypothesized to optimize nutrient removal were implemented into a modified bioretention system in Durham, NH. Monitoring of this system allowed for assessment of the effectiveness of the system configuration and filter media selection.

## **LITERATURE REVIEW**

During the course of this project, extensive literature review was undertaken. This included numerous papers concerning phosphorus sorption and use of Langmuir and Freundlich isotherm models, as well as considerations of other crucial bioretention soil mix (BSM) constituents, especially compost which has leaching potential. The author has also produced an extensive bioretention water quality database, based on review of over 70 studies of field and laboratory bioretention type systems (Roseen et al. 2013). The field systems from this bioretention database produced for Seattle Public Utilities (from this point forward referred to as the SPU database) provide some basis and context for the goals of the present study.

### **Bioretention Database Field System Nutrient Performance**

The bioretention database includes site characteristics and design criteria of individual field systems; water quality data includes median influent and effluent concentrations and median removal efficiencies for each system when available. Box-and-whisker plots below present statistics on median influent and effluent concentrations for nitrogen and phosphorus data for all of the systems which reported on these constituents. Available design criteria categories of particular interest to this project are also included. For phosphorus data, BSM design is of most importance, so sand and compost content categories are included. For nitrogen data, whether or not the system includes an internal storage reservoir (ISR) is of most interest.

Total phosphorus data indicates that effluent concentrations are not necessarily reduced from influent concentrations in general (Figure 4). Medians of the systems' orthophosphate (OP) effluent concentrations are generally higher than median influent concentrations (Figure 5). Although effluent OP and TP concentrations are generally lower for systems that contain compost, these systems also have lower influent concentrations than the other categories. Literature did not report many details about the type or quality of compost, which can vary widely. Thus, some composts may leach phosphorus, while others may not. Use of a local food and yard waste compost to support plant growth was a concern as a phosphorus source in effluent for this study. UNHSC has considered use of compost to support vegetation and significant sand content to maintain high infiltration rates as crucial components to a successful bioretention soil mix. Excessively high sand content in UNH Stormwater Center systems, however, has led to struggling plants in installations around the seacoast of New Hampshire, so it has been limited to 50-60% of the mix by volume in recently installed systems.

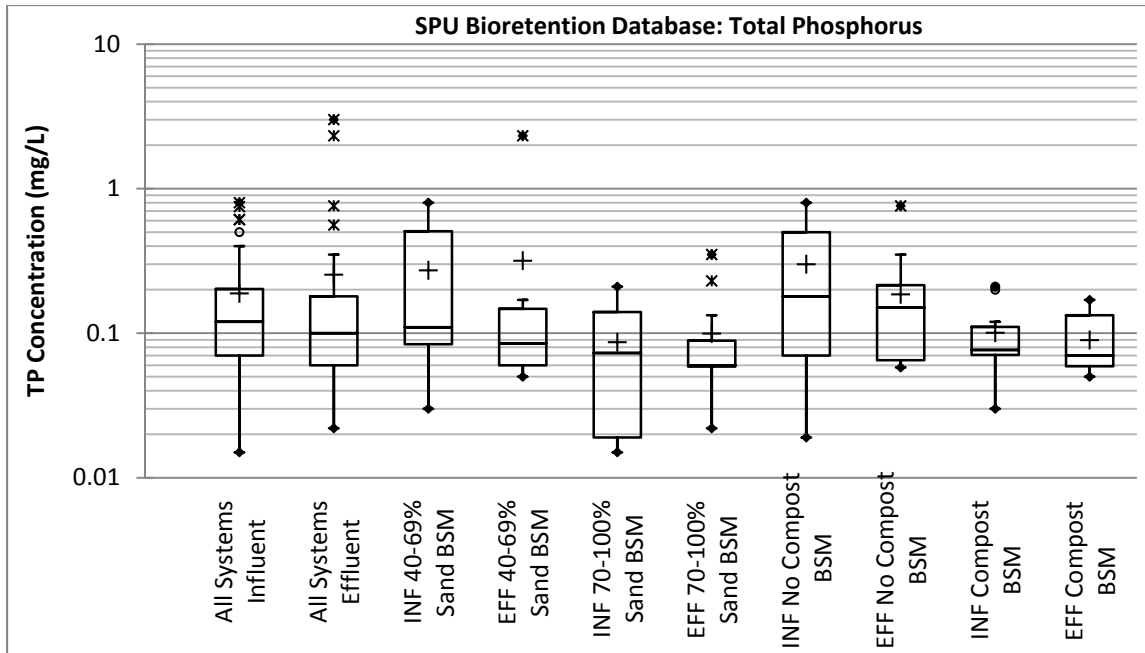


Figure 4. Box-and-Whisker Plots for Total Phosphorus from the SPU Bioretention Database.

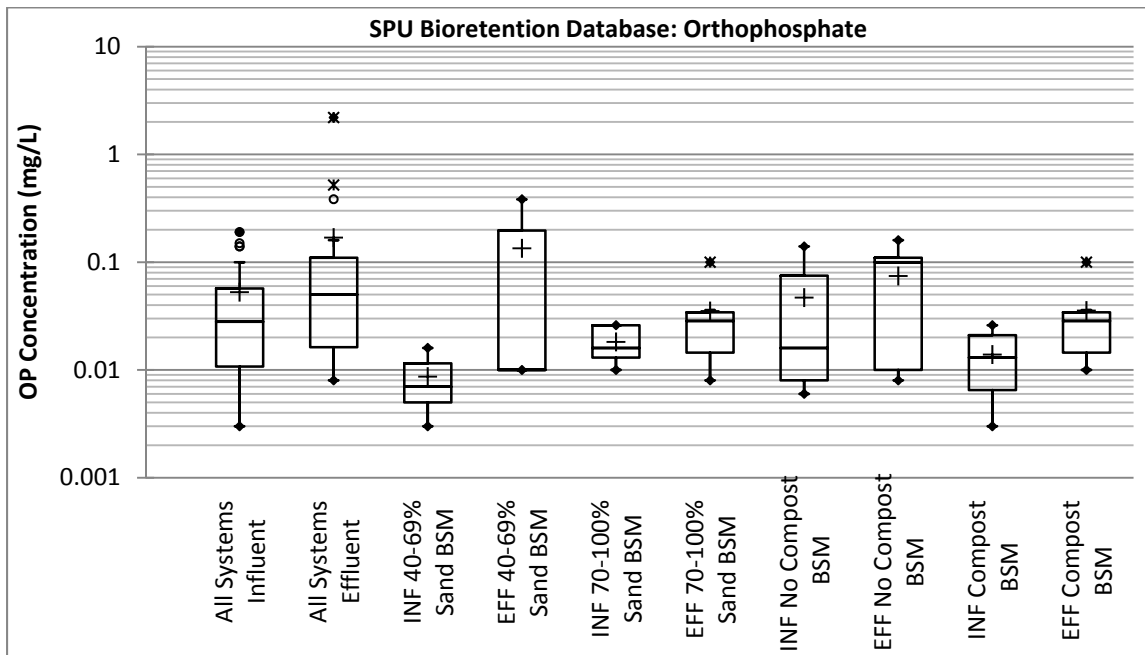
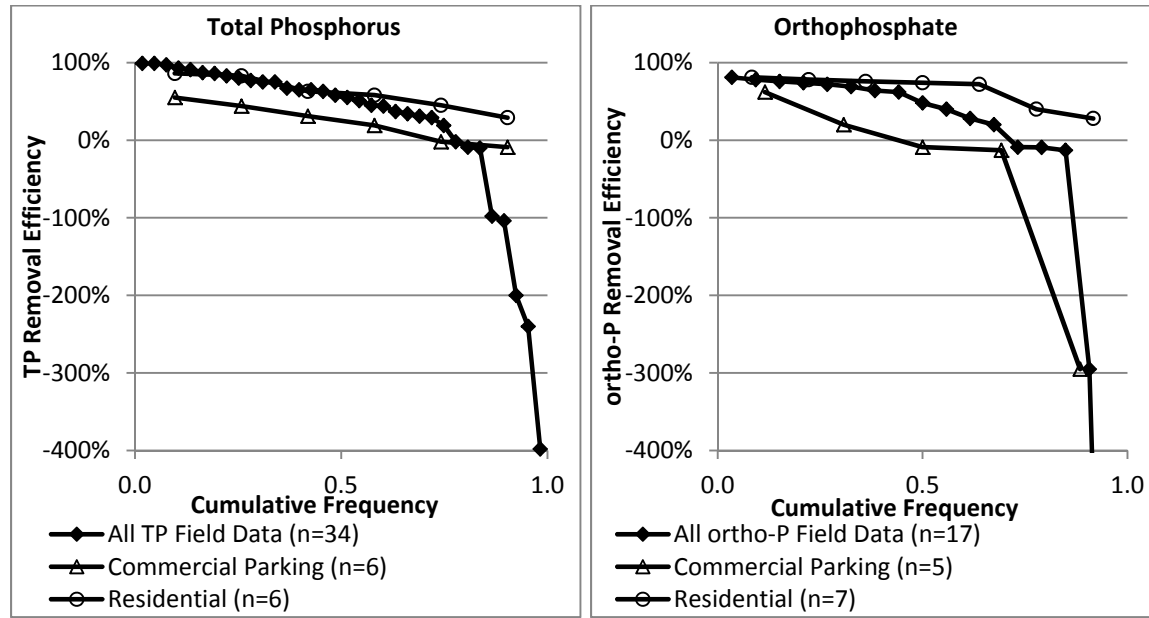


Figure 5. Box-and-Whisker Plots for Orthophosphate from the SPU Bioretention Database.

Another point that pertains to the present study is the difference made by land use. This project's study area is a highly trafficked parking lot located near Main Street and the primary commercial section of Durham, NH. As such, it falls within the commercial parking land use category in the cumulative distribution function below, which shows generally lower removal efficiencies from systems installed in this type of location (Figure 6). Though the difference appears small, note that a number of the removal efficiencies are highly negative, indicating significant leaching from some systems. Median TP removal from the systems in commercial parking areas is

actually only 25% removal, and median orthophosphate removal is -9%. According to this data, OP leaches from at least half of the systems built in commercial parking areas.



(a) (b)  
**Figure 6. Cumulative Frequency Functions of Total Phosphorus and Orthophosphate Removal Efficiencies in the SPU Bioretention Database.**

Though only a slight downward shift of TN and nitrate concentrations is observed from influent to effluent when all systems are considered, the statistics shift very clearly between effluent concentrations of systems with and without internal storage reservoirs (ISR). It appears that systems without ISR are likely to export TN and nitrate in particular, while systems with internal storage generally decrease concentrations (Figure 7 and Figure 8). The median removal efficiencies of bioretention systems in the SPU database are 42% for total nitrogen and 14% for nitrate.

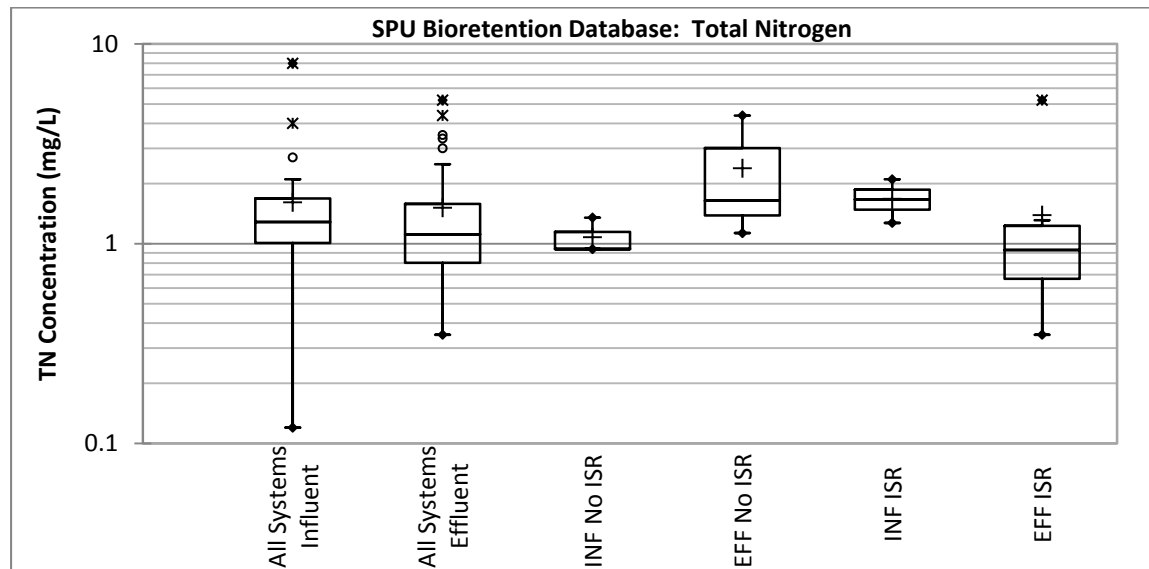


Figure 7. Box-and-Whisker Plots for Total Nitrogen from the Bioretention Database.

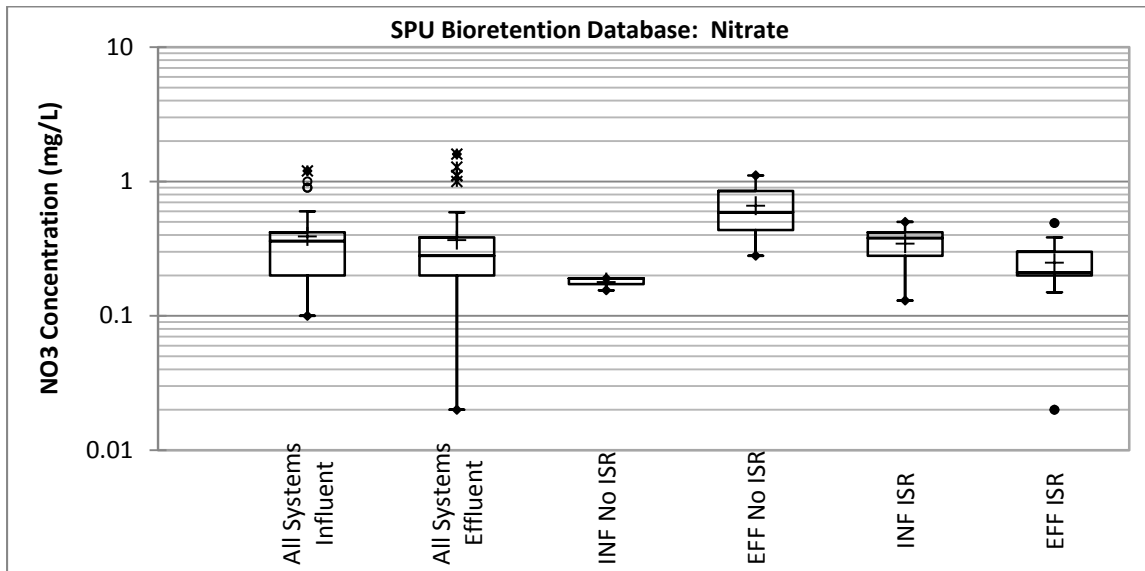


Figure 8. Box-and-Whisker Plots for Nitrate from the Bioretention Database.

## Compost and Leaching Potential

A number of studies have shown compost to leach both nitrogen and phosphorus, and several standards have been put forth to reduce leaching potential. A study of compost-amended soils by Pitt et al. (2001), using different types of compost to amend glacial till soils in Washington state, demonstrated significant leaching of nutrients from compost. While the 2:1 mixtures of soil to compost provided some benefits for biofiltration systems, such as increased infiltration rates, runoff volume capture and metals and toxicity removal, concentrations of nutrients increased on the order of 5 to 10 times over non-amended soils (Pitt et al. 2001).

A study of green roofs indicated the filter media used was a source of TN and TP (Hathaway et al. 2008). The filter media included 15% composted cow manure. The 2010 Regional Bioretention Soil Guidance Technical Memorandum for San Francisco Bay Area recommends avoiding the use of biosolids or manure composts due to their higher leaching potential for bio-available phosphorus (Stromberg 2010). This guidance document recommends using only yard, plant, or food waste composts certified through the US Composting Council (USCC) Seal of Testing Assurance (STA) program. It also recommends use of compost with a C:N ratio between 15:1 and 25:1 for the sake of plant health and minimization of nutrient leaching. It emphasizes the importance of using a stable compost for minimizing nutrient leaching, particularly nitrogen spikes (Stromberg 2010).

Leaching of both nitrogen and phosphorus occurred in columns studied by Hatt et al. (2007). Mixes used in that study included several amendments to sand and loam, including vermiculite, perlite, compost and mulch. While the phosphorus leaching was fairly consistent during the wet and dry periods through which the columns were run, effluent nitrogen concentrations spiked following dry periods, indicating that aerobic processes between storm events can make nitrogen available for leaching (Hatt et al. 2007). Hatt et al. (2007) describe this as “partly processed”

nitrogen, meaning it has undergone aerobic transformations to leachable oxides, i.e. nitrification, which is desirable if time and anaerobic conditions are also present to complete the process of denitrification to transform these nitrogen species to nitrogen gas so that it may escape into the atmosphere.

Another study showed that higher temperatures produced the most leaching, although they warn that the vegetation in the columns of the study had minimal time for establishment and may therefore have had limited uptake effect (Blecken et al. 2007).

Some are using peat or wood chips alone as a source of organic matter. Some WTR have some of the benefits that compost provides, including organic matter and adsorptive properties. The use of compost in bioretention systems is still a topic of debate among stormwater researchers and professionals.

### **Isotherm Models for P Sorption**

Many past studies have used the Langmuir phosphorus adsorption maximum ( $P_{\max}$ ) to predict the capacity of WTR to adsorb phosphorus (Dayton and Basta 2005; Dayton et al. 2003; Novak and Watts 2004; Sakadevan and Bavor 1998). While much effort has been spent on fitting the Freundlich isotherm model to P sorption data and many researchers declaring it as the best fit of the data (Kinniburgh 1986; Mead 1981; Sakadevan and Bavor 1998; Sansalone and Ma 2009), inherent concerns with broader applications of this model have led to it rarely being used to predict P sorption capacity of materials. The Langmuir models single layer adsorption, while the Freundlich is an empirical model of multilayer adsorption. According to Dayton et al. (2003), the Freundlich adsorption capacity parameter (K) is useful for comparison only if the materials have similar values of n, the unitless adsorption intensity parameter. Kinniburgh (1986) cautions that the Freundlich model may overestimate P adsorption if applied to concentrations outside the observed concentration range. According to Kinniburgh (1986), nonlinear least squares (NLLS) methods are best for fitting isotherm models, including the Langmuir and Freundlich models. Analyzing P sorption data from a separate study (Bache and Williams 1971), Kinniburgh (1986) states that the Langmuir is a poor fit and Freundlich is preferable, though he emphasizes the issue of concentration range. In comparison with the Langmuir and Temkin models, Freundlich was determined to be the most suitable model for soils used in Mead's study (1981). Mead suggests that if using the Freundlich isotherm model, native adsorbed phosphate should be estimated and included with the sorption data (1981). In analyzing isotherm data with the linear Langmuir equation, Novak and Watts (2004) subtracted the total phosphorus (TP) measured in soil tests of WTRs from the equilibrium concentrations as a correction before analyzing the data to determine a  $P_{\max}$  value.

Dayton et al. (2003) used the linearized Langmuir and the nonlinear Freundlich isotherm models to analyze P sorption data by 21 different WTRs from Oklahoma drinking water treatment plants. Both the Freundlich K and Langmuir  $P_{\max}$  correlate well to oxalate extractable aluminum content ( $Al_{ox}$ ) in Dayton's study; however, Freundlich K did not correlate to runoff P reduction in the simulated field study (Dayton et al. 2003). Langmuir  $P_{\max}$  is popular in use because it readily provides a sorption capacity or maximum, while other metrics require more in depth analysis and often questionable results (Dayton et al. 2003).

## **Correlating Al<sub>ox</sub> and Fe<sub>ox</sub> to P Sorption**

The oxalate extractable Al and Fe content describes the amorphous oxides of Al and Fe (Sakadevan and Bavor 1998). These are most reactive with phosphorus for sorption. Oxalate Extraction of Al, Fe, and P and the ratio of Al and Fe to P may be used to indicate the P sorption capacity (PSC) of materials (Dayton and Basta 2005; Dayton et al. 2003; Elliott et al. 2002; O'Neill and Davis 2012a; Sakadevan and Bavor 1998).

Dayton et al. (2003) recommended estimating P sorption for field application based on either the Langmuir P<sub>max</sub> value or Al<sub>ox</sub>, which were found to be correlated. This would mean at minimum either running an adsorption isotherm batch test or a soil test including oxalate extraction of Al. Some soil labs will run a Mehlich 3 extraction as part of typical soils tests rather than oxalate extraction. Mehlich 3 extraction is another estimate of amorphous aluminum. Mehlich 3 extractions may be used to estimate the Phosphorus Saturation Index (PSI), which is the ratio of oxalate extractable phosphorus to oxalate extractable aluminum and iron in a material (Tom Buob, personal correspondence). Dayton et al. (2003) did not observe correlation between any of the WTR Fe<sub>ox</sub> content and P sorption capacity. However, it must be noted that the Fe<sub>ox</sub> content was at least an order of magnitude lower than the Al<sub>ox</sub> content of nearly all of the 21 WTR used in this study, not unlike the Durham WTR.

Modeling P sorption data for several different adsorbents (soils, slags and zeolite), Sakadevan and Bavor found that the Freundlich isotherm equation was a better model overall, although for some materials the Langmuir equation modeled the P adsorption of the material as well or better (Sakadevan and Bavor 1998). Sakadevan and Bavor show that P adsorption (taken as the P<sub>max</sub> value from the Langmuir isotherm model) is well correlated to Al<sub>ox</sub> and to the combined Al<sub>ox</sub> and Fe<sub>ox</sub>. Correlation was also high between maximum P adsorption and total Al, total Fe, or total Al + Fe content (Sakadevan and Bavor 1998).

Dayton and Basta (2005) used the Langmuir P<sub>max</sub> value of WTR and assessed its relationship to oxalate extractable Al in WTR, proposing the oxalate extraction method as a simpler approach to predicting P sorption capacity. They tested both the oxalate extraction method and the sorption isotherm method in order to strengthen the relationship between P<sub>max</sub> and Al<sub>ox</sub>. They recommend a solution to WTR ratio of 100:1 for the oxalate extraction method and crushing WTR to < 150 microns (No. 100 sieve) for the isotherms (Dayton and Basta 2005).

## **Competing Ions, Aluminum Leaching Potential, and pH**

One concern about the addition of aluminum-based WTR to bioretention soil mixes is the potential for aluminum, a toxic metal, to leach from the system into water bodies. Sansalone and Ma (2009) concluded that the capacity for P adsorption is strongly dependent on pH, i.e. a lower pH increases P adsorption. However, a concern has been raised that aluminum oxides found in WTR may dissolve in strongly acidic soil environments (pH<5) (Gallimore et al. 1999). The WTR used in this current project are slightly acidic (pH = 6.8, 6.7, 6.4), while the other materials in the study range from slightly acidic to slightly alkaline. The Durham BSMs do not appear to be in any danger of becoming strongly acidic, so the aluminum oxides are expected to remain in insoluble forms. This was confirmed by testing for aluminum content in column study effluent.

Sansalone and Ma (2009) used the Freundlich isotherm to model P sorption by aluminum oxide coated media (AOCM). They also examined the effect of competing ions on P sorption, and determined that the difference in P sorption for a solution with 5 mg/L of nitrate versus none was statistically insignificant, while addition of sulfate did reduce P sorption (Sansalone and Ma 2009). The present study used runoff collected at the UNHSC field testing site in all laboratory studies to assure the presence of typical competing ions in all experiments.

### **Impact of WTR Aging**

McLaughlin et al. (1981) found that P sorption ability decreased with aging of Al-containing materials, while drying of Fe-containing materials at 80°C produced a similar effect. This suggests that since the WTR in my experiments were dried, the Fe content in the WTR, which is already low compared to the Al content, is likely rendered completely useless, at least in comparison to the Al content. However, drying does not seem to have an effect on the Al crystallinity, which impacts reactivity (McLaughlin et al. 1981). When considering Al content, it is important to consider a possible decrease in PSC in older WTR.

### **WTR and Nitrogen**

While the focus of WTR additions to soils has been P removal, Gallimore et al. attributed the high cation exchange capacity (CEC) of their ABJ WTR with adsorption of NH<sub>4</sub>-N. Their WISTER WTR had a much lower CEC than ABJ and did not show significant N removal of any kind. WTR were air-dried prior to application (Gallimore et al. 1999). Gallimore et al. refer to Freundlich K values from Peters and Basta to explain the comparative results of the two WTR used in this land application study (Gallimore et al. 1999).

### **Extrapolating Isotherm Data to Field Application**

Novak and Watts (2004) proposed WTR as a chemical-based BMP for reducing P runoff from agricultural lands treated with manure. They ran isotherms on two soils, two WTRs, and several mixes of the soils amended with varied amounts of WTR. To extrapolate the lab data to the field scale, they converted the varied mixes of WTR:soil ratios to practical field application of WTR. For the WTR added in tons per hectare, assuming a certain depth of soil, the WTR additions correspond to certain WTR:soil ratios used in the lab.  $P_{max}$  values for those ratios are plotted and a regression line is fit to the data. Due to the variation in  $P_{max}$  values, Novak and Watts (2004) recommend using standard P sorption isotherms to determine P binding potential before WTR field application.



## **METHODS AND MATERIALS**

### **Experimental Design**

The experimental side of this project consisted of two major phases: a laboratory phase and a field phase. The laboratory phase focused on the design of a bioretention soil mix (BSM) for phosphorus adsorption. The field phase of the project consisted of design, construction, and monitoring of a modified bioretention system with WTR-amended filter media and internal storage reservoir structural design. Table 1 summarizes the experiments undertaken for this project and the goals of each. Batch equilibrium experiments and column studies were expanded to include several phases each in order to meet the goals of this project. Adsorption kinetics studies determined the equilibration time necessary for batch equilibrium isotherm studies. Isotherm models allow for determination of a phosphorus sorption capacity (PSC) of materials, assuming that batches reach equilibrium and maintain constant temperature. The purpose of these experiments was to expand the characterization of bioretention soil mix (BSM) materials beyond that provided by soil tests. Column studies were performed to assess the filtration performance of BSMs.

The second major phase of the project, the field portion, included the design and construction in 2011 of two side-by-side bioretention systems with differently sized internal storage reservoirs for promoting denitrification. These systems were monitored for a suite of contaminants, including the various species of nitrogen and phosphorus. This dataset was then compared with the long term dataset from UNHSC monitoring projects for several other vegetated systems. These systems included two bioretention systems of a more traditional design and a subsurface gravel wetland.

**Table 1. Summary of Experiments.**

Experiment	Purpose
Soil Tests	Pre-characterization of filter media constituents and mixes
Batch Kinetics Studies	Equilibration time for batches of nutrient spiked runoff mixed with:
Phase 1	Filter media constituents (<74 µm grain size)
Phase 2	Large (<2mm) grain size WTR
Phase 3	Other WTR samples; time steps added
Batch Equilibrium Isotherm Studies	Sorption capacity for batches of nutrient spiked runoff mixed with:
Phase 1	Filter media constituents
Phase 2	Filter media mixtures (BSMs)
Column Studies	Removal effectiveness of filter media
Phase 1	Columns with dewatered WTR-amended filter media; long term nutrient loading (45 years)
Phase 2	Duplicate columns with raw WTR-amended filter media; long term nutrient loading (45 years)
Phase 3	Short and long term nutrient loading (1-2 years up to 20 years); expanded filter media selection
Field Monitoring	Removal effectiveness of modified bioretention system

A solution of stormwater runoff harvested from the distribution box at the UNH Stormwater Center was used for all laboratory water quality experiments. A summary of constituents in the runoff is provided in Table 2. Nitrate and orthophosphate (OP) concentrations were spiked to desired levels by measured additions of the ASTM/EPA standard for nitrate nitrogen and  $\text{KH}_2\text{PO}_4$  solutions. Unless otherwise noted, influent for all experiments was spiked to approximately 5 mg/L nitrate as N and 1 mg/L OP as P.

**Table 2. Harvested Stormwater Runoff used as base solution for laboratory experiments.**

Analyte	Runoff Result	Detection Limit	Units
Diesel Range Organics (DRO)	< 270	270	ug/L
Zinc	0.02	0.01	mg/L
Ammonia as N	< 0.5	0.5	mg/L
Nitrate-N	0.3	0.1	mg/L
Nitrite-N	< 0.1	0.1	mg/L
ortho-phosphate as P	0.02	0.01	mg/L
Total Phosphorus as P	0.04	0.01	mg/L
Total Kjeldahl Nitrogen (TKN)	0.7	0.5	mg/L
Nitrogen, total	1	0.5	mg/L

Experiments were run in UNH labs in Gregg Hall and Kingsbury Hall. Chemical analyses were performed by outside labs, while the following physical analyses were performed in house to supplement other laboratory experiments: moisture content analysis, particle size determination, density measurements, and constant head permeameter tests.

## **BSM Materials**

The University of New Hampshire Stormwater Center (UNHSC) BSM designs have historically consisted of four materials: coarse sand, commercial loam, shredded wood chips, and food and yard waste compost. UNHSC mix designs were used as the base mix for this project. All materials came from local sources; an alternative compost provided by Agresource, Inc. was used in one experimental BSM. This compost (compost2) was a leaf and yard waste compost from Melrose, MA with low phosphorus content, compared to the typical food and yard waste compost (compost1) with high P leachability used in UNHSC bioretention systems.

For this project, the portion of compost in previously established mixes is split between compost and water treatment residuals (WTR) from the Durham drinking water treatment plant. Four WTR samples were used in this study, all collected from the Durham/UNH Drinking Water Treatment Plant lagoon on the UNH campus (see Figure 9). Samples 1 and 4 underwent some processing that increased their solids content, while samples 2 and 3 were essentially raw WTR. WTR1 was collected in February 2011, frozen in a walk-in freezer in Gregg Hall, thawed, and then decanted prior to use in any experiments. The freeze/thaw process dramatically increased solid/liquid separation, such that WTR sediment was collected from the bottom of the bucket after decanting water off the top. WTR2 was collected in June 2011 from the top layer on the far side of the lagoon, having dried in the sun over the warm and dry summer months (see Figure 10). WTR3 was collected in October 2011 following heavy rains, with the consistency of a very wet sludge. Samples of WTR3 were partially dried in a low oven to boost solids content prior to its use as an admixture to BSMs. WTR4 was collected in May 2012 from a large container next to the lagoon. The container was filled in summer 2011 with wet sludge and endured several freeze/thaw cycles over the winter, which accelerated solid/liquid separation.



**Figure 9. WTR Lagoon at the Durham Drinking Water Treatment Plant.**

*The foreground is the area where WTR are dumped in the lagoon, containing the freshest WTR (WTR3); In the background near the trees is the older, drier WTR (WTR2). Photo by Robin Stone.*



**Figure 10. Far side of WTR lagoon at Durham Drinking Water Treatment Plant.**

*Older WTR are dried and cracked from exposure to air and sun over the summer. Pictured, a backhoe extracts the top layer of WTR for use in the Durham Bioretention system (Column Phase 2 BSM.10, Column Phase 3 BSM3). Photo by Robin Stone.*

## **Analytical Procedures**

Two external labs were used for the majority of the analyses: Agricultural Analytical Services laboratory at Pennsylvania State University (PSU) and Absolute Resource Associates laboratory in Portsmouth, NH.

Soil matrix samples were taken of each of the materials considered for use as a constituent in BSMs for this study and characterized by the Penn State lab. The materials analyzed were a coarse sand, commercial loam from LandCare, wood chips, 2 batches of compost (local food and yard waste compost and low P leaf and yard waste compost), and 4 batches of WTR all harvested from the Durham drinking water plant at various times of the year. The BSM installed in the optimized Durham bioretention system was also analyzed. For each sample, two reports were requested. The Biosolids and Septage Spreading Report includes soil pH, Mehlich 3 concentrations of Ca, Mg, K, P, Al and Fe, as well as an estimated P saturation using the ratio of Al and Fe to P (see Appendix A). The Compost Report includes SME pH, % organic matter, % nitrogen, est. C/N ratio, total Phosphorus, total Potassium, NH<sub>4</sub>-N, SME concentration, total Aluminum, Ca, Mg, Na, Cu, Fe, S, and Zn concentrations (see Appendix A).

Water matrix samples from the lab and field phases of the project were analyzed by Absolute Resource Associates in Portsmouth, NH. Lab phase samples were analyzed for orthophosphate by either the 365.3, 365.1 or the 300.0A methods and for nitrate using the 300.0A method. The 365.3 or 365.1 methods were preferred for this study due to the low detection limits (0.001 or 0.020 mg/L as opposed to the 0.01 mg/L detection limit for the 300.0A method).

Field phase samples were analyzed for the suite of contaminants, including nitrogen species, phosphorus species, sediments, and metals (see Appendix A for methods and detection limits of each analyte). All water quality samples that were reported as below detection limit (BDL) from the analytical labs were used in data analysis at values half of the method detection limit (Helsel and Hirsch 2002). That is to say, when the method detection limit for orthophosphate at ARA was 0.01 mg/L, samples that returned from the lab as BDL were entered for data analysis as 0.005 mg/L.

## **Batch Equilibrium Studies**

Batch equilibrium studies provide information on the phosphorus sorption capacity (PSC) of materials for this project. These studies were conducted at room temperature (20-25°C) in Gregg Hall and Kingsbury Hall labs on the University of New Hampshire main campus. Each batch consisted of a) 100 mL of natural stormwater collected from the Distribution Box at the UNH Stormwater Center and spiked with phosphate and nitrate standard solutions to approximately 1 mg P/L of OP and 5 mg N/L of nitrate, and b) a mass amount of dried and sieved BSM or BSM constituent (sand, loam, WTR, etc.) ranging from 10 to 160 mg. Batches were placed in 250mL Erlenmeyer flasks, covered with parafilm, and shaken on a lateral shaker table at 200 rpm for a pre-determined amount of time. Samples were then taken from each batch, filtered to remove particulates, and sent to the Absolute Resource Associates (ARA) lab for analysis of orthophosphate and nitrate concentrations in the water matrix. The first round of kinetics and isotherm studies was conducted in spring 2011, and all samples were filtered with Whatman™ 0.45 micron syringe filters at the time of sampling. For the studies conducted in fall 2011 and

spring 2012, Whatman GF/F™ glass microfiber filters (0.7 micron nominal size) were used to filter samples due to their ease of use and sufficient removal of particulates. All samples were kept at 4°C until analysis by ARA.

## **Kinetics Studies**

To determine the time to equilibrium of batches, kinetics studies were run. The first test was run in April 2011. Samples of BSM constituents (sand, loam, compost and WTR1) were each dried in a low oven, crushed, and sieved past a No. 200 sieve (74 µm). Each of the four samples was measured out in 100 mg aliquots and mixed with 100 mL of spiked stormwater in a 250 mL flask, then shaken for varied amounts of time. A batch of each material was removed from the shaker table and sampled at set time steps of 1, 2, 4, 6, 8, 18, 24, and 48 hours. A second kinetics study was run in September of 2011 on WTR2 only. These samples were crushed and sieved past a No. 10 sieve (2 mm), thus the nominal grain size was more than an order of magnitude larger. An additional time step at 60 hours was added for this second study. The final kinetics study was run in January 2012 with both the second and third batches of WTR (WTR2 and WTR3), following the same procedure as in April 2011, with the exception of some alteration to time steps: 2, 4, 8, 18, 24, 36, 48, 72, and 96 hours.

## **Isotherm Studies**

Adsorption isotherms consist of batches of varied mass amounts of material mixed with spiked stormwater. The procedure for the isotherm study mimics that for the kinetics study, with the variation in mass amount of material, rather than variation in time step. Having established 48 hours as a conservative estimate of time to equilibrium from the kinetics study, all batches in the isotherm study were shaken for 48 hours, again at 200 rpm. For each BSM or BSM constituent, a batch was made for each of the following mass amounts of material: 10, 40, 70, 100, 130, and 160 mg. Each of these were mixed with 100 mL of spiked stormwater in a 250 mL Erlenmeyer flask and shaken. The first set of isotherms ran in April 2011 on BSM constituents: sand, loam, compost, WTR1. The second set ran in January 2012 on WTR2 and WTR3. The final isotherm study in May 2012 ran on BSMs themselves. The BSMs were mixed in the highbay on a % volume basis with materials in raw form (i.e., no processing, such as freeze/thaw processing, drying or sieving). Post-mixing, a sample was taken of each and dried and sieved, just as were the constituents for previous studies.

## **Column Studies**

### **Permeameter Tests**

The saturated hydraulic conductivity ( $k_{sat}$ ) of each of the final mixes was measured using a constant head permeameter according to ASTM 2434—68. Preliminary tests of four mixes, two with and two without WTR, provided an idea of infiltration rates and the effect of WTR on infiltration rates prior to running column tests in 2011. Permeameter tests were run for all mixes used in the final column test in 2012 (phase 3 columns).

## **Column Setup**

Columns consisted of 3 foot long clear PVC pipe sections, with inner diameter (ID) of 1.75 inches for the phase 1 column tests, and ID of 1.5 inches for phases 2 and 3. Each column was capped with a rubber plumbing cap, with a hole drilled into it for influent/effluent tubing to fit into it. Influent was delivered to the columns by way of a multichannel peristaltic pump (phases 2 and 3), capable of delivering influent to 5 different columns at the same rate at the same time. Overflow drains were drilled into the side of each column approximately 6 inches above the top of the filter media. This allowed the influent to pond without overflowing the column and maintained a mostly constant head throughout each simulated event. During column phase 1, influent was delivered by way of adjustable gravity feed tanks and somewhat consistent ponding was maintained by manual adjustments to each feed tank. No overflow drains were used in phase 1, and consistency of ponding proved difficult to maintain.

All columns were packed with 2-3 inches of pea gravel at the bottom, followed by 24 inches of BSM. With each 6 inches of BSM loaded into the column, it was compacted, with either a drop of a PVC pipe with rubber stopper on the end from a 12 inch height or by knocking the bottom of the column against the stabilizing board several times to cause settling. For Column Phase 1, rubber rings were inserted at approximate depths of 4 and 14 inches below the top of BSM in the columns to keep water from routing along the sidewalls of the columns. For Column phase 2 and 3, no rings were used, and columns were fitted with an overflow drain at approximately 6 inches above the top of the BSM, in order to keep a more consistent head on the system during simulated rainfall events. Simulated rainfall events consisted of loading columns with spiked stormwater runoff as the influent.

Stormwater runoff from the West Edge parking lot at UNH was collected at the distribution box of the UNH stormwater center. Additions of phosphate and nitrate standard solutions raised the OP and NO<sub>3</sub> levels to the desired concentrations for each set of experiments.

## **Column Sampling Regimens**

Influent samples were taken and analyzed for OP and NO<sub>3</sub> prior to each column run. Effluent sampling for phase 1 and 2 column tests consisted of collecting all of the effluent for a single simulated event, mixing it and sampling from 3.5-5.5 L of effluent. Each sample was analyzed for OP and nitrate. One sample was taken from the effluent of each column after each simulated event. During phases 2 and 3, occasional samples were taken for aluminum analysis in order to test if aluminum was leaching out due to the presence of aluminum-based WTR.

During the phase 3 column test, samples were taken directly from the effluent draining out of the columns once a predetermined volume of effluent had accumulated.

Start and end times of each column run and/or sample time, as well as effluent volume at each sample time were noted for all column phases. This data provided a measurement of media infiltration rates as follows:

$$Q = \frac{V_{EFF}}{t}$$

**Equation 5. Column Infiltration Rate Estimation**

where Q = infiltration rate (mL/min),  $V_{EFF}$  = volume of effluent (mL), and t = time step for collection of given volume of effluent (min).

Given an empty bed volume of 811 mL in phase 1 (due to larger cross-sectional area of columns in this phase) and 695 mL in phases 2 and 3, empty bed contact time was calculated using the infiltration rate data for each sample:

$$EBCT = \frac{BV}{Q}$$

**Equation 6. Empty Bed Contact Time**

where EBCT = empty bed contact time (min) and BV = bed volume (mL).

## Hydraulic and Nutrient Loading

The total hydraulic load to each column during phases 1 and 2 was approximately equivalent to the mean annual rainfall over the course of a year in seacoast New Hampshire (46 inches), assuming a ratio of 20:1 for the drainage area to filter area; this is a typical ratio for bioretention design. The filter area in the case of the columns is the cross-sectional area of the columns. Multiplying that by a factor of 20 and by the 46 inches of rain provides the volume to be delivered to each column for a year of hydraulic load. The actual influent delivered was less than intended due to a failure of the system to deliver the entire prepared influent amount. Losses during phase 1 were large, amounting to a loss of about 8 inches of total simulated rainfall; whereas, losses during phase 2 amounted to only about 1 inch.

The load was delivered in five events for Phase 1 and in seven events for Phase 2, with 24 hours between the start times of each event. Stormwater harvested from the UNHSC West Edge facility distribution box was spiked to 1 mg P/L of OP and 5 mg N/L of nitrate. Therefore, the nutrient load to the columns is much higher than a one year load. Based on influent data from the Durham bioretention system monitoring, expected orthophosphate (OP) concentration is considered to be 0.02 mg/L for this project. Based on this expected average value for 46 inches of annual rainfall, each event amounted to about 9 years of OP loading in phase 1 and 6.5 years of loading in Phase 2. All columns in phases 1 and 2 were loaded with a total of about 45 years of OP load each.

A primary goal of the phase 3 column test was to assess the early performance of BSMs, particularly since the design life of bioretention systems is typically not more than about 20 years. Harvested stormwater was spiked to 0.2 mg/L of OP and 0.5 mg/L of nitrate for the first run of phase 3, which delivered a one year nutrient load (a 1/10 hydraulic load) to each of the columns. Columns were sampled at 4 intervals during the simulated event. This process was repeated for a second year of nutrient loading.



The secondary goal of phase 3 was to verify isotherm models by running the columns to breakthrough, at which time the adsorptive properties of the BSM may be considered exhausted. Therefore, future runs in Phase 3 used stormwater spiked to 1 mg/L of OP and 5 mg/L of nitrate as in the previous column study phases, higher concentrations allowing breakthrough to be achieved more quickly. The columns were allowed to sit for 5 days before longterm loading began. Samples were taken after the equivalent of 2 years of nutrient loading up to the 20 year nutrient load level. Although all column influent was spiked for both orthophosphate and nitrate, phase 3 column samples were only analyzed for orthophosphate, because media composition is believed to have little effect on nitrate removal, as was confirmed by phase 1 and 2 nitrate results.

## **Column Contents**

When designing a bioretention soil mix (BSM), it is necessary to consider several factors related to its infiltration rate and ability to serve as a filter. The water quality volume is the volume of runoff that the system is expected to treat, and a system must be large enough and/or infiltrate quickly enough to capture and treat that volume. Bioretention systems are typically expected to drain down within 24 hours of a storm, meaning that the infiltration rate is high enough that no water is left ponding after 24 hours. These considerations must be weighed against the components and contact time necessary to effectively remove contaminants. The UNHSC typically uses a 50% sand mix to provide a high infiltration rate without negatively impacting the vegetation in the system. Native plants commonly used in bioretention systems cannot thrive in a soil that is too sandy. A tree filter is essentially a small bioretention system with a single tree as its only vegetation. Due to its smaller size and not needing to keep many bushy plants alive, these systems typically have a much higher percentage of sand in an effort to infiltrate runoff more quickly, while still effectively filtering out contaminants.

The composition of mixes used in each of the column studies is provided in Table 3, with percentages on a volume/volume (v/v) basis. A typical tree filter mix of 80% sand and 20% compost was altered to replace a quarter of the compost portion with WTR (TF.05), giving this mix an overall 5% v/v ratio of WTR in phase 1 of column studies. Tree filter mixes in phases 2 and 3 increased the WTR volume ratio to 10% of the mix. The typical UNH Stormwater Center BSM is 50% sand as stated above, 20% compost, 20% wood chips, and 10% loam. The BSMs used in the columns contained varied amounts of WTR and compost. Still working with the 20% compost, 5-15% of the overall mix were replaced with WTR. Different batches of WTR were used in the BSMs for phases 1, 2, and 3. The mixes are identified by the type of mix and percentage of WTR in the mix (see Table 3). The tree filter mix is considered a BSM but is identified by the initials TF to distinguish it from other mixes with the same percentage of WTR. Phase 2 columns were run in duplicate.

Several mixes were added for phase 3, including a “Control” mix that contains no WTR, a mix containing no compost, and a mix containing an alternative compost with lower P content. Only the Durham Bio mix was run in duplicate in phase 3.

**Table 3. Composition of Bioretention Soil Mixes for Column Studies.**

Phase 2 mixes were run in duplicate, with the designation of “-1” or “-2” after each mix name. Compost1 is the local compost generally used. Compost2 is a certified compost from Melrose, MA with lower Mehlich 3 P content than standard compost. WTR1 was frozen and decanted. WTR2 was air and sun-dried in the lagoon over the summer. WTR3 was fresh sludge.

Name	Description	Sand	Wood Chips	Loam	Compost1	Compost2	WTR1	WTR2	WTR3
<i>Phase 1</i>									
TF.05	Tree Filter Mix w/5% WTR	80%			15%		5%		
BSM.05	BSM w/5% WTR	50%	20%	10%	15%		5%		
BSM.10	BSM w/10% WTR	50%	20%	10%	10%		10%		
BSM.15	BSM w/15% WTR	50%	20%	10%	5%		15%		
RG.05	Rain Garden Mix w/5% WTR	43%		43%	9%		5%		
<i>Phase 2</i>									
TF.10-1/2	Tree Filter Mix w/10% WTR	80%			10%			10%	
BSM.05-1/2	BSM w/5% WTR	50%	20%	10%	15%			5%	
BSM.10-1/2	BSM w/10% WTR	50%	20%	10%	10%			10%	
BSM.15-1/2	BSM w/15% WTR	50%	20%	10%	5%			15%	
<i>Phase 3</i>									
BSM 1	No Compost BSM	50%	20%	20%					10%
BSM 2	Low P Compost BSM	50%	20%	10%		10%			10%
BSM 3	Durham Bio (BSM w/10% WTR)	50%	20%	10%	10%			10%	
BSM 4	Tree Filter Mix w/10% WTR	80%			10%				10%
BSM 5	Control (No WTR)	50%	20%	10%	20%				
BSM 6	BSM w/5% WTR	50%	20%	10%	15%				5%
BSM 7	BSM w/10% WTR	50%	20%	10%	10%				10%
BSM 8	BSM w/15% WTR	50%	20%	10%	5%				15%

## Data Analysis Methods

### Isotherm Model Fitting

For each BSM or BSM component sample (adsorbents), six isotherm batches were equilibrated, one with each sediment mass amount ( $M= 10, 40, 70, 100, 130, \text{ or } 160 \text{ mg}$ ). Data points were calculated for  $q$ , the equilibrium adsorbent phase concentration of OP in mg P/g adsorbent, given the known volume ( $V= 100\text{mL}$ ) of spiked stormwater, mass of sediment ( $M$ ), starting adsorbate phase concentration ( $C_0 \sim 1\text{mg/L}$ ) of OP in solution and the measured equilibrium concentration of OP in solution ( $C$ , mg/L). The observed values ( $q_0$ ) were calculated as in Crittenden et al. (2005):

$$q_0 = \frac{V}{M} (C_0 - C)$$

**Equation 7. Observed Adsorbent-Phase Concentration**

The Langmuir isotherm models a single layer adsorption process with the equation:

$$q_L = \frac{Q_M b C}{1 + b C}$$

**Equation 8. Langmuir-Modeled Adsorbent-Phase Concentration**

where  $q_L$ = equilibrium adsorbent-phase concentration of OP modeled by Langmuir, mg P/g adsorbent;  $Q_M$ = maximum adsorbent-phase concentration of OP when surface sites are saturated with OP (also sometimes labeled  $P_{\max}$ ), mg P/g adsorbent;  $b$ = Langmuir adsorption constant of OP, L/mg P;  $C$ = equilibrium concentration of OP in solution, mg P/L (Crittenden et al., 2005). This equation can be rearranged into a linear form:

$$\frac{C}{q_L} = \frac{1}{bQ_M} + \frac{C}{Q_M}$$

**Equation 9. Linearized Langmuir Equation**

where  $1/(bQ_M)$  is the intercept and  $1/Q_M$  is the slope of a line plotting  $C$  against  $C/q$ . Linear regressions were performed on the data for each sediment sample, and the parameters  $b$  and  $Q_M$  were calculated. These parameters were then used to calculate equilibrium adsorbent-phase concentration of OP ( $q$ , mg P/g adsorbent) using Equation 7 for each equilibrium concentration of OP in solution ( $C$ , mg P/L). These are the Langmuir predicted values ( $q_L$ ) for the statistical analysis.

The Freundlich isotherm model is an empirical equation used to describe multi-layer adsorption:

$$q_F = KC^{1/n}$$

**Equation 10. Freundlich-Predicted Adsorbent-Phase Concentration**

where  $q_F$ = equilibrium adsorbent-phase concentration of OP modeled by Freundlich, mg P/g adsorbent,  $K$ = Freundlich adsorption capacity parameter,  $(\text{mg/g})(\text{L/mg})^{1/n}$ ;  $1/n$ = Freundlich adsorption intensity parameter, unitless. The base 10 logs of equilibrium concentration of OP in solution ( $C$ , mg P/L) and equilibrium adsorbent-phase concentration ( $q_O$ , mg P/g sediment) are plotted against one another, and a linear regression performed, yielding the transformed equation:

$$\log(q_F) = \log(K) + \left(\frac{1}{n}\right) \log(C)$$

**Equation 11. Linearized Freundlich Equation**

From the linear regression, the Freundlich parameters are determined, using  $K=10^{\text{intercept}}$  and  $1/n=\text{slope}$ . These parameters are used to calculate the equilibrium adsorbent-phase concentration of OP ( $q_F$ , mg P/g adsorbent) using Equation 10 to provide the predicted values for the Freundlich model.

**Statistical Analysis of Isotherm Models**

Several measures are used to assess the fit of the two isotherm models to the data. First, the R-square values of each of the best fit lines to the isotherm data for each model was assessed. Next, a series of model assessment measures, comparing observed and modeled values, proposed by Willmott (1982) were used to further assess the models.

A simple comparison of the first two moments (mean and standard deviation) of the modeled values with those of the observed values provides an idea of how well the models represent the data. Also, linear regressions were performed on these data sets comparing observed vs. modeled values; a good model will have a nearly 1:1 linear regression.

Difference measures reported include the mean absolute error (MAE) and the root mean square error (RMSE), which summarize the mean differences between observed values and modeled values of each of the models. They were calculated for this study as in Willmott (1982):

$$\text{MAE} = \frac{1}{N} \sum_{i=1}^N |M_i - O_i|$$

**Equation 12. Mean Absolute Error**

$$\text{RMSE} = \sqrt{\frac{1}{N} \sum_{i=1}^N (M_i - O_i)^2}$$

**Equation 13. Root Mean Square Error**

where N is the number of data points,  $M_i$  is the  $i$ th modeled value, and  $O_i$  is the  $i$ th observed value. The index of agreement (d) is also reported, taking the form from Willmott (Willmott 1982):

$$d = 1 - \left[ \frac{\sum_{i=1}^N (M_i - O_i)^2}{\sum_{i=1}^N (|M_i'| - |O_i'|)^2} \right] \quad 0 \leq d \leq 1$$

**Equation 14. Index of Agreement**

where  $M_i' = M_i - O$  and  $O_i' = O_i - O$ . The unsystematic RMSE (RMSEu) is reported and is expected to be near 0 for a good model. The systematic RMSE (RMSEs) should be near the RMSE.

Finally the Nash-Sutcliffe efficiency (N-S Eff) is reported to measure the fit of the modeled values with the observed values (Nash and Sutcliffe 1970). The efficiency is calculated as follows (Jacobs et al. 2009):

$$\text{N-S Eff} = 1 - \left( \frac{\sum_{i=1}^N (O_i - M_i)^2}{\sum_{i=1}^N (O_i - \bar{O})^2} \right)$$

**Equation 15. Nash-Sutcliffe Efficiency**

where  $\bar{O}$  is the mean of the observed values.

## Model Verification

Removal efficiencies (RE) were calculated for each of the columns and may be compared to field data removal efficiencies to determine the ability of the column tests to predict field performance. Removal efficiency is calculated as

$$\%RE = \left( 1 - \frac{C_{EFF}}{C_{INF}} \right) \times 100$$

**Equation 16. Removal Efficiency**

where  $C_{INF}$  = influent concentration (mg/L) and  $C_{EFF}$  = effluent concentration (mg/L).

Efficiency ratios (ER) were also calculated for both column and field system data, as follows:

$$ER = \frac{\overline{EMC}_{INF} - \overline{EMC}_{EFF}}{\overline{EMC}_{INF}}$$

**Equation 17. Efficiency Ratio**

where  $\overline{EMC}_{INF}$  = event mean concentration of influent, averaged over all monitored storms or simulated storms and  $\overline{EMC}_{EFF}$  = event mean concentration of effluent, averaged over all monitored storms or simulated storms. The ER is often more resistant to extreme values than the removal efficiency.

Summary statistics for column and field system data included approximate 95% confidence intervals. Because the data was generally nonnormal, a nonparametric method of confidence intervals about the median was used (Helsel and Hirsch 2002). The method uses the ranked data to determine the interval. Since the interval must include an actual ranked data point, the actual confidence in the interval varies (generally between 94% and 98%, depending on the size of the dataset, N). Mean, standard deviation, and coefficient of variation are also reported.

Cunnane plotting positions were used for all cumulative distribution function figures, as presented in Helsel and Hirsch (2002):

$$p_i = \frac{i - 0.4}{n + 0.2}$$

**Equation 18. Cunnane Plotting Position**

where  $p_i$  = plotting position for the  $i$ th ranked data value, from smallest to largest,  $i$  = the rank of the data value, and  $n$  = the total number of data values (Helsel and Hirsch 2002). The plotting position associated with the median of a dataset is  $p_i = 0.5$ . Plotting positions represent the non-exceedance probabilities for given data values.

## Design of a Bioretention-Gravel Wetland Hybrid

An innovative bioretention system was designed and constructed based on the concepts of using the functional mechanisms of a gravel wetland, and replicating them in the footprint of a standard bioretention system (Roseen et al 2011). From the surface, the system does not look any different than a standard bioretention system. However, in the subsurface it incorporates an anaerobic internal storage reservoir (ISR) in the same sense that is accomplished in a gravel wetland. Of primary significance in this design is the ISR, the long circuitous flow path, and the volume contained in the ISR. A traditional bioretention system has approximately 2 feet of vertical filter path length as it moves through the bioretention soil media prior to exiting by underdrain or exfiltration. A gravel wetland typically has at least a 30' horizontal flowpath through the anaerobic ISR. A gravel wetland typically contains about 25% of the WQV in the ISR. This innovative system replicates this to a lesser degree. The ratio of the ISR/WQV is believed to be a crucial element of the design in that it is based on the phenomena that nitrate is heavily first flush weighted, and should wash off in the beginning of a storm event, or a small fraction of the WQV. The nitrate first flush was observed for storms of multiple sizes by Roseen et al (2006).

Two side-by-side systems were installed in a commercial parking lot on Pettee Brook Lane in Durham, NH, in summer 2011. Partners in this installation were the Town of Durham NH, US EPA Region 1, and the UNHSC.

These two systems contain the same BSM: 50% sand, 10% compost, 20% wood chips, 10% loam, and 10% WTR2 (identical to BSM.10 from column phase 2 and BSM3 in column phase 3). These two systems are known as Bio 5 with Cell 1 and Cell 2. Bio 5, and other systems, including a subsurface gravel wetland system (GW) and two standard bioretention systems (Bio-3 and Bio-4), were monitored for nitrogen and phosphorus removal.

The design of the parallel systems in Durham is nearly identical, except for the difference in the sizing of the internal storage reservoir. Cell 1 was designed to capture a drainage area of 13,400 ft<sup>2</sup> and hold 20% of the water quality volume in the ISR. Cell 2 was designed to capture a drainage area of 17,200 ft<sup>2</sup> and 10% of the WQV in the ISR (Figure 3). The layout and long section detail of the cells are shown in Figure 11 and Figure 12. A walkway divides the cells, which are each about 32 feet in length and 6 feet wide. UNHSC specifies a minimum 30 foot horizontal flow path in the designs for subsurface gravel wetlands to allow space and time for the denitrification process to occur in the subsurface storage reservoir. The Bio-5 cells were designed with a minimum horizontal flow path of 22 feet in the internal storage reservoir (Figure 12). Depth of BSM in these systems is 2 feet. A 6 inch pea gravel (3/8" diameter) layer lies below the BSM to prevent migration of the BSM into the crushed stone (3/4" diameter) layer. The crushed stone layer varies between 3.32 and 3.75 feet deep in Cell 1 and only 2.08 and 2.50 feet deep in Cell 2. This layer provides the internal storage reservoir; since the outlet from the system is at the top of this layer, this layer is permanently saturated. The greater depth of the stone layer in Cell 1 provides more storage space than in Cell 2 (see also Figure 13 for the cross section).

A geomembrane of high-density polyethylene (HDPE) was placed in the stone layer of each cell at a 1% slope to increase the travel distance of the water to be treated. Water is forced to travel

horizontally around the membrane and through the stone layer to the outlet. This provides a minimum travel distance of 22.17 feet.

The cells were both designed for a maximum ponding depth of 4 inches, with an overflow grate sitting 4 inches above the BSM surface. Similar to a gravel wetland, the system outlets are orifice controlled with a design release rate of 24 hours. They are vegetated with native plants, and the surface is dotted with round river stones.

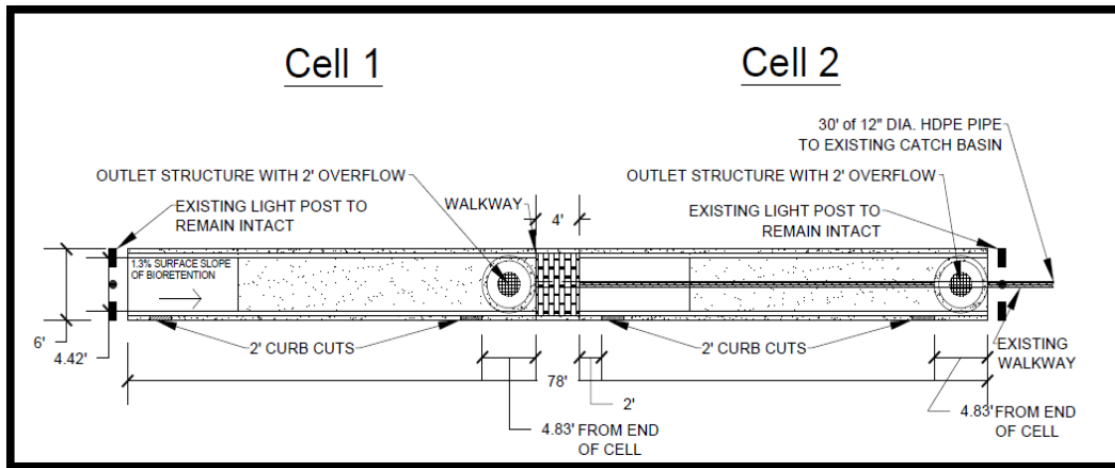


Figure 11. Layout of Durham Bio-5 Bioretention Cells.

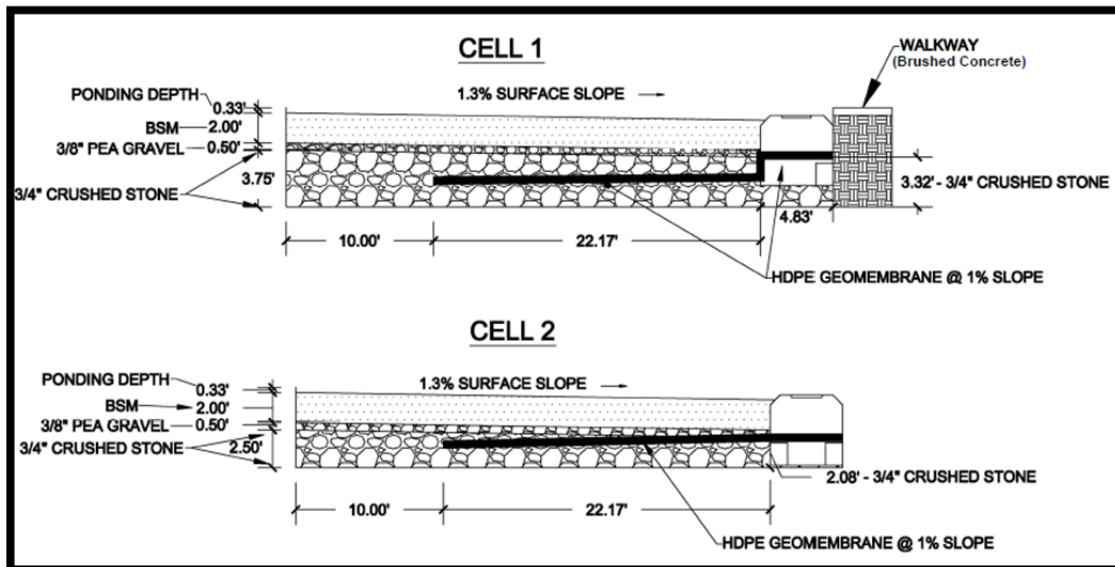


Figure 12. Long Section of Durham Bio-5 Bioretention Cells.



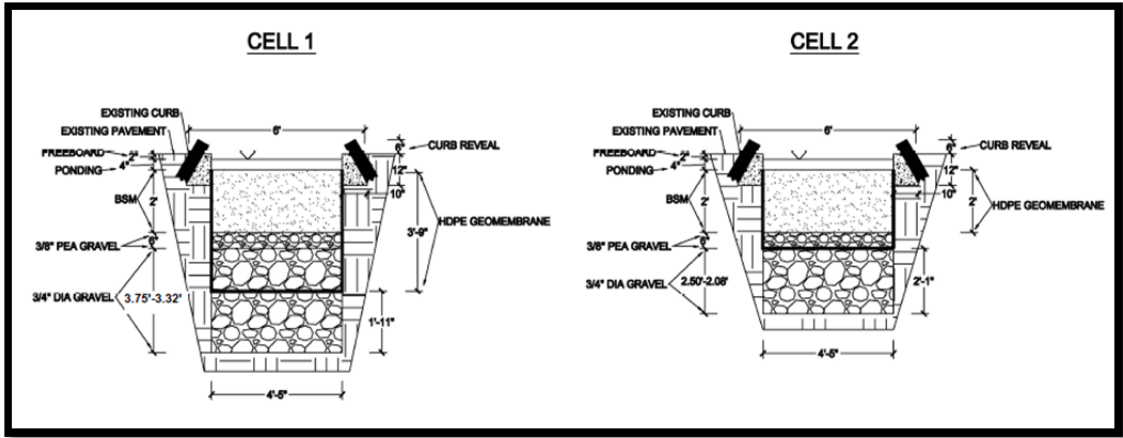


Figure 13. Cross-Section of Durham Bio-5 Bioretention Cells.

## RESULTS AND DISCUSSION

### Soil Test Results

Materials characterization was important in this study because of the wide variation observed in materials used in bioretention soil mixes, particularly within compost and WTR (see Table 4, Appendix A for full soil reports). Of particular interest to this project are the contents of available phosphorus, aluminum and iron, measured by the Mehlich 3 extraction method. Mehlich 3 and oxalate extraction are both methods to estimate the amount of reactive element present in the soil matrix. At the PSU Agricultural lab, Mehlich 3 extraction was the method available, though oxalate extraction is a commonly preferred method in other studies due to greater accuracy (Dayton and Basta 2005; Dayton et al. 2003; Elliott et al. 2002; O'Neill and Davis 2012a; Sakadevan and Bavor 1998).

The P saturation index is defined as the ratio of reactive P to reactive Al and Fe (typically using oxalate extractable values, but estimated here using the Mehlich 3 method). A low P saturation index indicates a low available P content relative to the available Al and Fe content in a material, which is desirable for this study. Table 4 presents these values. O'Neill and Davis (2012a) propose the oxalate ratio (OR) as a measure of P leachability. OR is essentially the inverse of the P saturation index:

$$OR = \frac{(Al_{ox} + Fe_{ox})}{P_{ox}}$$

#### Equation 19. Oxalate Ratio

where  $Al_{ox}$ ,  $Fe_{ox}$ , and  $P_{ox}$  are the oxalate-extractable Al, Fe, and P contents of a material in mmol/kg, here approximated with Mehlich 3 extraction (see Table 4). This measure relates equivalents of cations Al and Fe with phosphorus. Other anions that may react with P include calcium (Ca) and magnesium (Mg). Phosphorus leachability is likely in materials with OR less than 10 (O'Neill and Davis 2012a).

The four batches of WTR analyzed in the present study have the lowest P saturation indices, ranging from 0.07% to 0.37%, by more than an order of magnitude in comparison to other materials, as well as the highest reactive aluminum contents (1588-2330 ppm). These corresponded to very high OR ranging from 270 to 1429. Sand and loam had low P saturation indices (4.59% and 7.44%, respectively), corresponding to  $OR > 10$ . Compost1 is oversaturated with P, with an index of 140.92%, and compost2 appears to be much less likely to leach P, based on its lower P saturation index (37.73%). From this data, we hypothesized that BSMs with no compost or with compost2 included will leach less than those with compost1 included in the mix. Based on OR recommendations from O'Neill and Davis (2012a), both composts used in this study, but none of the other components, carry a high risk of leaching P ( $OR < 10$ ). Although the C:N ratios fall within the recommended range of 15 to 25 to avoid nutrient leaching, the ratios of the two composts are on the low end of this spectrum at 15.0 and 16.6 for compost 1 and 2, respectively.

**Table 4. Materials Characterization.**

Material	Description	P <sub>Meh</sub> (mg/kg)	Al <sub>Meh</sub> (mg/kg)	Fe <sub>Meh</sub> (mg/kg)	Est P Sat <sup>a</sup>	Oxalate Ratio <sup>b</sup>	Oxalate Ratio <sub>meas</sub> <sup>c</sup>	Est C:N Ratio	Al <sub>Meh</sub> /Al <sub>T</sub>	Moisture Content	Density <sup>c</sup> (g/mL)
<i>Components</i>											
Sand		35.0	619.3	93.8	4.59%	21.8		68.3	0.14	0.41%	1.91
Wood Chips										63.15%	0.49
Loam	NH commercial	121.0	1291.3	258.5	7.44%	13.4		13.7	0.20	18.74%	1.26
Compost1	NH food & yard	853.0	408.4	246.4	140.92%	0.710		15.0	0.19	71.94%	0.65
Compost2	MA leaf & yard	252.0	448.0	276.0	37.73%	2.65		16.6	0.11	43.28%	0.80
WTR1	indoor freeze/thaw	8.0	2000.9	157.1	0.34%	294		44.8	0.24	66.78%	0.85
WTR2	sun-baked	7.0	1588.0	109.0	0.37%	270		24.3	0.07	90.96%	0.95
WTR3	fresh, soupy	4.0	2050.0	132.0	0.16%	625		20.6	0.27	94.69%	0.93
WTR4	outdoor freeze/thaw	2.0	2330.0	139.0	0.07%	1429		22.8	0.04	58.94%	0.68
<i>Mixes</i>											
BSM1	No Compost BSM							22.2		21.49%	1.52
BSM2	Low P Compost BSM							22.2		21.43%	1.53
BSM3	Durham Bio (BSM w/10% WTR)	90.0	1292.0	135.0	5.78%	17.3	21.9	21.5	0.23	20.25%	1.45
BSM4	Tree Filter Mix w/ 10% WTR							23.5		12.86%	1.77
BSM5	Control (No WTR)							19.6		18.59%	1.39
BSM6	BSM w/5% WTR							21.1		21.09%	1.40
BSM7	BSM w/10% WTR							22.6		22.04%	1.52
BSM8	BSM w/15% WTR							24.2		24.10%	1.60

<sup>a</sup> Ratio of Mehlich 3 extracted elements of P/Al+Fe. The actual P sat. would be based on oxalate extraction.

<sup>b</sup> OR as defined in O'Neill and Davis 2012.

<sup>c</sup> OR estimated from dry mass composition of BSM components.

<sup>d</sup> Density of materials was measured at field moisture.

Eight different bioretention soil mixes (BSM1-8) were examined in both batch equilibrium isotherm studies and column studies (phase 3). Moisture content and density of the BSMs and the materials that comprise them were used to calculate characteristics of the BSMs based on dry mass. Materials were mixed into BSMs at field moisture on a volume basis. However, phosphorus sorption capacity, as determined from soil tests and from batch equilibrium isotherm tests, is based on dry mass of sorptive materials and cation equivalents present in these variable materials. The cations responsible for sorption of phosphate are primarily Al and Fe, as listed above, but also include calcium (Ca) and magnesium (Mg). Therefore, the sum of cation equivalents present in a sorptive material may be used as an indicator of its phosphorus sorption capacity relative to other sorptive materials (see Appendix A for sum of cation equivalents data).

Numerous studies report WTR content and BSM composition on a dry mass basis or a weight to volume (w/v) basis plants. These components occupy a much smaller percentage of the overall mix on a dry weight basis (Hsieh and Davis 2005; Hsieh et al. 2007; Lucas and Greenway 2011a; O'Neill and Davis 2009; O'Neill and Davis 2012a; O'Neill and Davis 2012b). The volumetric and dry mass composition of the BSMs examined in equilibrium and column studies for this project are shown in Figure 14 and Figure 15, respectively. Compost and wood chips are often considered beneficial components in bioretention systems for their moisture holding capacity, as well as their organic content, to support mass basis. Raw WTR, as used in this study, has a very high moisture content, and therefore the dry mass content of WTR in all mixes is <1%. This is a potential concern since past studies include WTR at a minimum of 2% on a weight to volume basis (Lucas and Greenway 2011a; O'Neill and Davis 2009; O'Neill and Davis 2012a; O'Neill and Davis 2012b). The adsorption process is based on the availability of solid aluminum (hydr)oxide sites as well as other available cation sites to which dissolved phosphorus may adsorb. Adding raw WTR with very high water content provides fewer sorption sites for removing phosphorus than do sorbent materials with higher solids contents added at the same volume ratio.

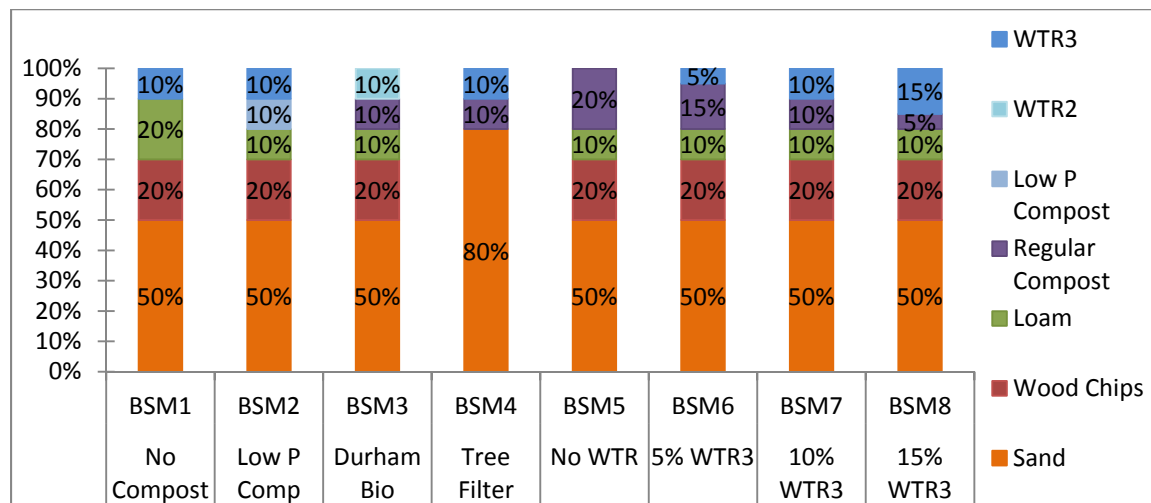
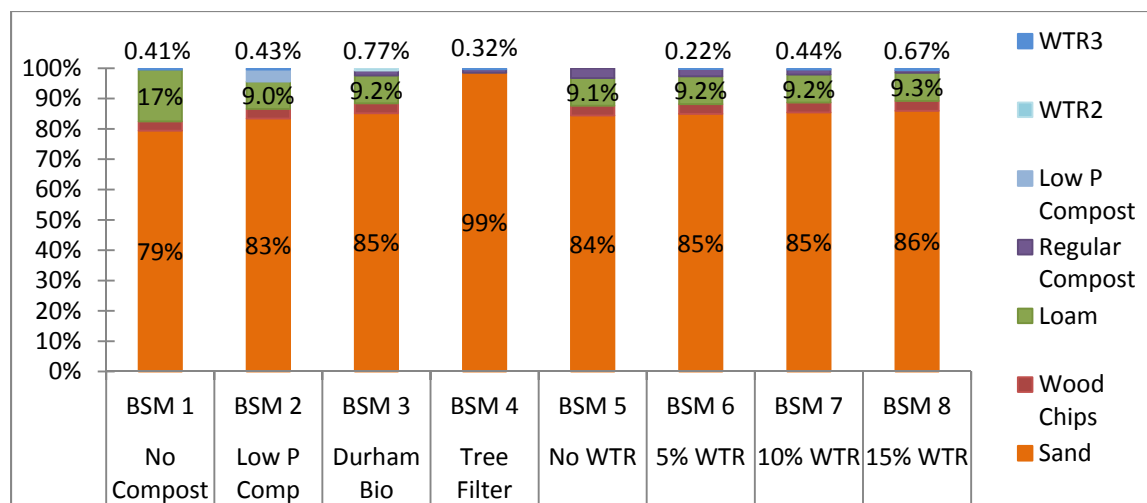


Figure 14. BSM Composition on a volume basis



**Figure 15. BSM Composition on a dry mass basis**  
 Numbers above the columns represent the % WTR content in the BSM on a dry mass basis.

The Durham bioretention mix with 10% WTR2 has a measured oxalate ratio (OR) of 17.3 (Table 4), which is comparable to the lower end of WTR-amended mixes tested by O’Neill and Davis (2012a), which ranged from an OR of 8.60 up to 95.2. O’Neill and Davis (2012b) concluded, however, that a suitable OR should be at least 20 to 40 for optimal phosphorus removal. Although full soil tests were not performed on the other BSMs, we can estimate the OR of those based on the components analysis. Comparison between the measured (17.3) and calculated (21.9) OR for BSM3 indicate that the calculation method overestimates the OR of mixes. WTR3 has a measured OR more than twice that of WTR2, but it also has about half the solids content of WTR2. Since WTR amendments were added by volume rather than mass, each of the mixes containing 10% WTR2 or WTR3 likely have similar oxalate ratios. The control mix may be expected to have an OR much lower than the other mixes, because it contains only components with OR an order of magnitude lower than WTR.

## Batch Equilibrium Test Results

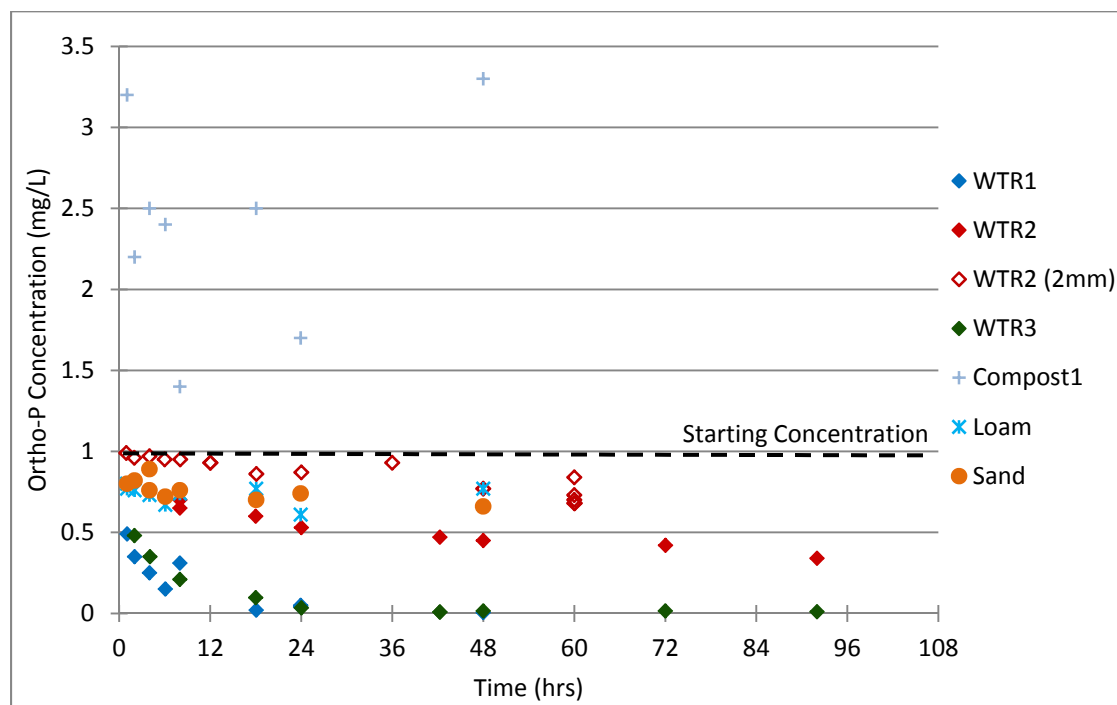
### Kinetics Studies

Kinetics studies revealed the reaction times between batches of combined nutrient spiked stormwater and BSM constituents or BSMs themselves. The kinetics of the BSM constituents with regard to orthophosphate (OP) adsorption revealed WTR to be the slowest material to reach equilibrium. In fact, some investigators have suggested that true equilibrium between WTR and phosphorus is not reached in such studies due to slow-reaction phosphorus that continues to sorb to WTR after short-term phosphorus sorption (Hsieh et al. 2007; O’Neill and Davis 2012b). The kinetics studies revealed high phosphorus leaching from compost1. As seen in Figure 16, compost leaching appears somewhat erratic without any leveling out within 48 hours.

The other materials all have some positive sorption capacity, with WTR having the greatest capacity, though variable among WTR samples (see Figure 16). Sand and loam both appear to have a moderate sorption capacity which is reached within the first 4-6 hours of contact. WTR1

and WTR3 perform very similarly, each with greater than 95% removal by 24 hours, which appears to be where the concentration levels out. It was decided that 48 hour shake time was a conservative time to equilibrium for the batches.

OP concentrations at equilibrium were near or below detection limit for WTR1 and WTR3 samples. However, both large and small grain size samples of WTR2 maintained higher OP equilibrium concentrations. It is presumed that the poor removal of OP by the 2mm grain size WTR2 is partially a result of larger grain size having fewer sorption sites due to reduced surface area compared to smaller grain size samples. Equilibrium OP concentrations in batches containing the other WTR2 sample, sieved to the same nominal grain size as WTR1 and WTR3 samples (74  $\mu\text{m}$ ), were still higher than batches containing WTR1 and WTR3 as sorbents (0.45 mg P/L for WTR2 and <0.02 mg P/L for WTR1 and WTR3 at 48 hours). This is likely due to the fact that WTR1 and WTR3 were the fresher samples taken near the area of the lagoon where the fresh residuals are regularly disposed, whereas WTR2 was sampled from the far side of the lagoon. Aging of aluminum hydroxides has been reported to reduce P sorption ability in a four week timeframe (McLaughlin et al. 1981). Further, it is worth noting that the starting OP concentration for the second and third round kinetics studies, which include the data for WTR2 (small and large grain size) and WTR3, was 1.1 mg/L, while the starting concentration for the first kinetics study was 0.9 mg/L (see data tables in Appendix B). Variability of sorption capacity is examined further in the analysis of isotherm data, which was obtained by shaking a variable mass amount of sorbent material with spiked stormwater for the chosen 48 hours of equilibration time.



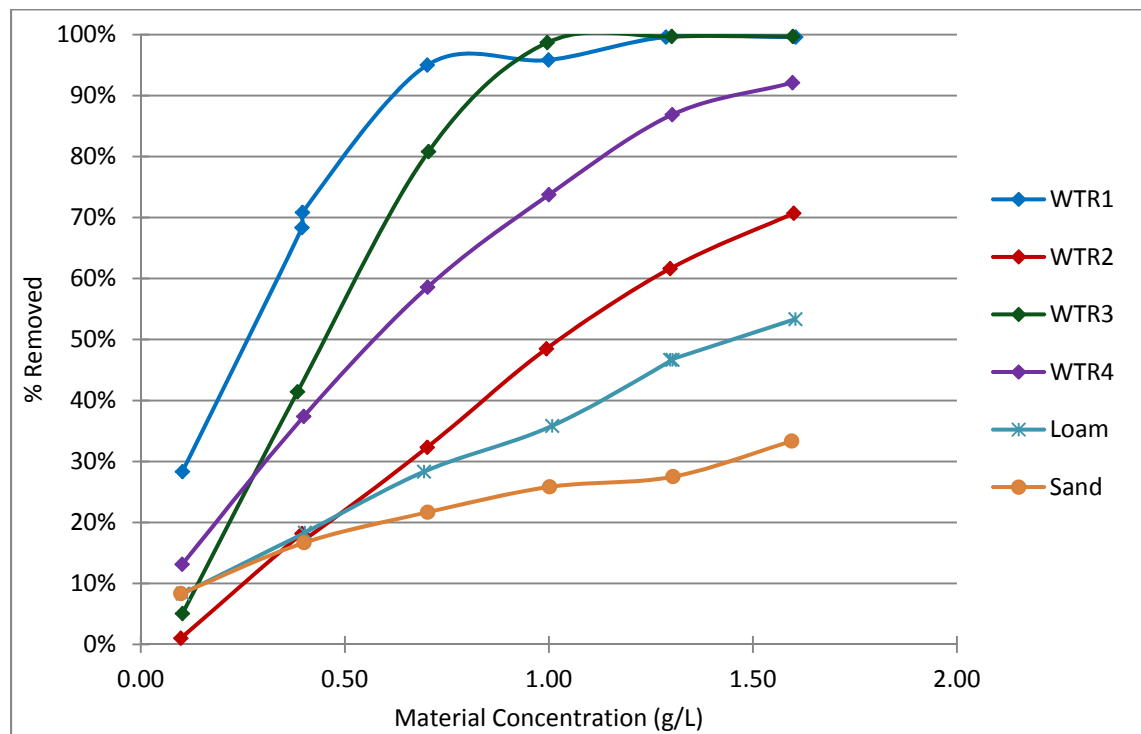
**Figure 16. Kinetics Study Results.**

All materials were sieved to a nominal grain size of 74 microns, with the exception of WTR2 with the open markers, with the nominal grain size of 2 mm noted in parentheses. The “Starting Concentration” line is an approximation, as it varied somewhat.

## Adsorption Isotherm Studies

Adsorption isotherm studies were performed to determine the phosphorus sorption capacity (PSC) of materials. Figure 17 confirms the relative sorption capacity determined by the kinetics studies with the addition of data for WTR4. The relative sorption of BSM constituents is WTR1 ~ WTR3 > WTR4 > WTR2 > Loam > Sand >> Compost1. Compost1 leaches; therefore, it is not shown in the figure because negative removal data distorts the scale. As mentioned above, wood chips are also a BSM component, but were not included in the batch equilibrium tests, due in part to the logistical challenges of analysis. O'Neill and Davis (2012a) found that hardwood bark mulch contributed to sorption of dissolved phosphorus, so it is likely that wood chips also contribute to P sorption, perhaps on an order similar to sand and loam.

WTR4 are also more aged than WTR1 and WTR3, having sat in a container from summer 2011 until spring 2012. The relative age of WTR4 to WTR2 is unknown. McLaughlin's (1981) work suggests that WTR age is inversely related to the sorption capacity. Though it cannot be confirmed with this data, the behavior of these samples does not contradict their findings (McLaughlin et al. 1981).



**Figure 17. Adsorption Isotherm Data for BSM Constituents.**

*Compost not shown to preserve the scale of the figure, since it leached (negative removal).*

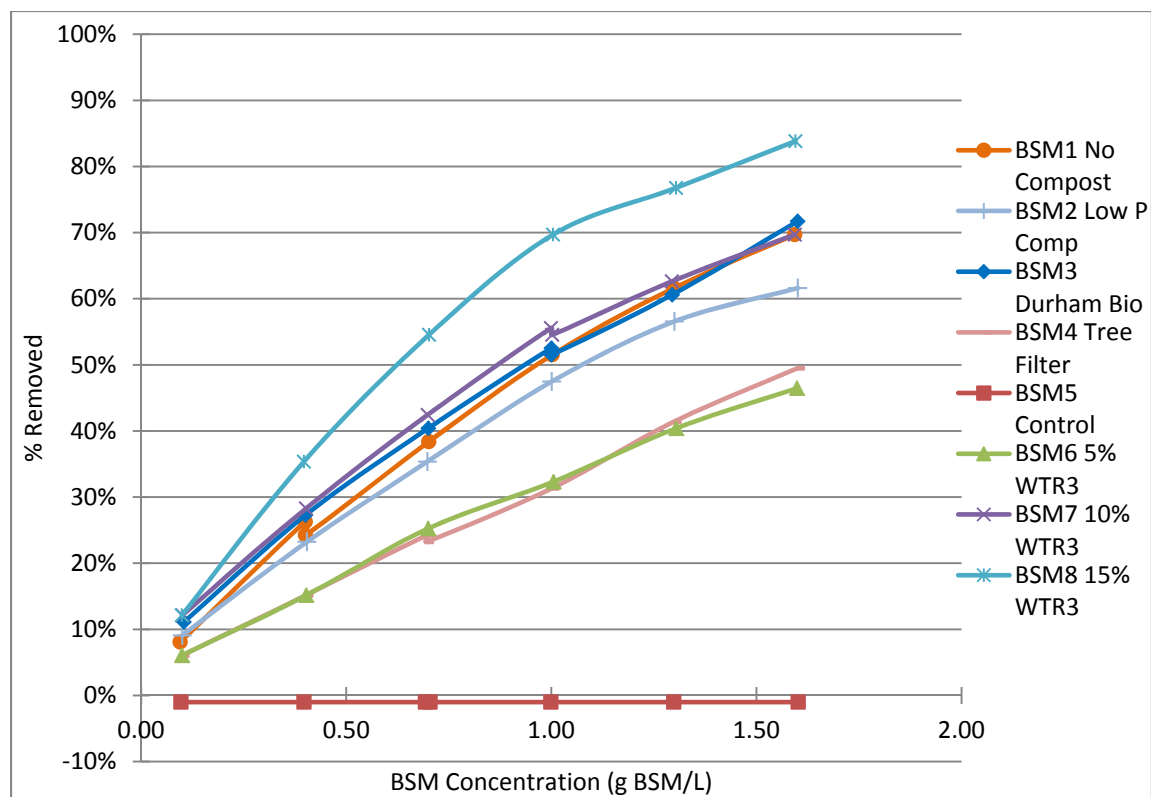


Figure 18. Adsorption Isotherm Data for BSMs

BSM isotherm data in Figure 18 appears to confirm the effectiveness of WTR as an admixture within a BSM. The control mix, which was the only BSM to contain no WTR, saw no significant change from the starting OP concentration in any of the batches throughout the experiment. This seems to indicate that the sand, loam, and wood chips provided sufficient sorption capacity to counteract the leachability of compost, but no additional sorption capacity. Each of the mixes containing WTR demonstrated fair to very good PSC, with the mix containing the greatest amount of WTR (15%) having the highest PSC. The tree filter mix (80% sand, 10% compost1, 10% WTR3) performed about as well as the 5% WTR3 mix. The rest of the mixes, each containing 10% WTR by volume, are grouped together in between. The superior PSC of loam as compared to sand may be to blame for the poor performance of the tree filter mix.

It is interesting to note that the Durham Bio mix (50% sand, 20% wood chips, 10% loam, 10% Compost1, 10% WTR2) seems to have a similar PSC as the same mix with 10% WTR3 (Figure 18), although according to Figure 17 WTR3 has a higher PSC than WTR2. With WTR seeming to have the most significant influence on mix PSC, the Durham Bio mix was expected to have a decreased PSC. However, the higher solids content of WTR2 allowed a greater dry mass of WTR in the Durham Bio mix (0.77%) than in the 10% WTR3 mix (0.44%, see Figure 15). Thus, it may be at least equally as desirable to use an older WTR if it has a higher solids content.

The replacement of compost1 with compost2 in the “low P compost” BSM2 did not seem to increase the performance of the mix in isotherm studies. Its PSC was the lowest of the mixes containing 10% WTR, with the exception of the tree filter mix. As with WTR2 and WTR3, compost1 and compost2 differ in solids content, and in the compost case in density as well. The



% mass content of compost2 in the low P compost mix was highest (4%) of all the compost-containing mixes, including the control (3.2% of total mix by mass). The dry mass compost content in mixes orders them as follows: BSM1(none) < BSM8 < BSM4 < BSM3 = BSM7 < BSM6 < BSM5 < BSM2 (see Table 5). Since the isotherms are based on dry masses of materials, these differences in dry mass content of constituents influence the results of the isotherm study. However, the question of whether these factors will be important in a field moisture context are better answered by column studies.

**Table 5. Mass % Composition of BSMs**

Name	Description	Sand	Wood Chips	Loam	Compost 1	Compost 2	WTR2	WTR3
BSM 1	No Compost BSM	79%	3.0%	17%				0.41%
BSM 2	Low P Compost BSM	83%	3.2%	9.0%		4.0%		0.43%
BSM 3	Durham Bio (BSM w/10% WTR2)	85%	3.3%	9.2%	1.6%		0.77%	
BSM 4	Tree Filter Mix w/10% WTR3	99%			1.2%			0.32%
BSM 5	Control (No WTR)	84%	3.2%	9.1%	3.2%			
BSM 6	BSM w/5% WTR3	85%	3.2%	9.2%	2.4%			0.22%
BSM 7	BSM w/10% WTR3	85%	3.3%	9.2%	1.6%			0.44%
BSM 8	BSM w/15% WTR3	86%	3.3%	9.3%	0.8%			0.67%

To predict column performance from isotherm data, Langmuir and Freundlich isotherm models were investigated. Each of these models has been used to evaluate P sorption capacity (PSC) in previous studies (Dayton and Basta 2005; Hsieh et al. 2007; Novak and Watts 2004; O'Neill and Davis 2012b; Sakadevan and Bavor 1998; Sansalone and Ma 2009). As described in the methods section, the Langmuir and Freundlich models may be linearized to determine their parameters through linear regression. However, first, a quality assessment of the isotherm data was undertaken. Thus, some data points were removed from the analysis to improve the model prediction.

As seen in Figure 17, nearly 100% removal is achieved by WTR1 and WTR3 with solid phase concentrations of 1.3 and 1.6 mg/L. This is an indication that the capacity of the materials exceeds the available load. Had more phosphorus been available for removal, it likely would have been removed by the 1.6 mg/L batch. Thus, for these materials, the final data point was removed from the isotherm model analysis. A potential source of error observed during the experiments was the attachment of adsorbent materials to the sides of the flasks, reducing the contact between adsorbent and solution. This appeared to be a particular problem for WTR and loam. The 10 mg batches (0.10 g/L solid phase concentration) contained such a small amount of adsorbent that it was determined that even a small amount of material separated from the solution was influencing the results to an unacceptable degree. For WTR2, WTR3, WTR4, and loam, the 0.10 g/L batch data points were removed for this reason. The 40 mg batches (0.40 g/L solid phase concentration, in duplicate) exhibited the same type of behavior for WTR2. For WTR2 in particular, these samples distorted the isotherm models to indicate that WTR2 does not consistently adsorb phosphorus, despite the fact that all samples did indeed remove dissolved phosphorus. Thus, these data points were also removed from the model analysis in order to not

distort the models. The quality assessment of the BSM isotherm data consisted of removal of the 0.10 g/L solid phase concentration data points for the same reason as given above.

The Langmuir isotherm model linear regressions are presented in Figure 19 and Figure 21. This model plots the equilibrium OP concentration ( $C$ , mg/L) against the inverse of the solid phase equilibrium concentration ( $q$ , mg OP/g adsorbent) multiplied by  $C$ . The solid phase equilibrium concentration refers to the mass amount of OP sorbed to the adsorbent. This model must be used with caution, however, since the equilibrium concentration is used in both the dependent variable as well as the independent variable. A particularly high correlation is expected from well-modeled data.  $R^2$  values for the BSM constituents are good (0.80 for loam) to excellent ( $>0.98$  for WTR2-4), and they are mostly very good for the BSM isotherm data as well (0.87 for the tree filter mix on the low end and 0.99 for the 15% WTR3 mix on the high end).

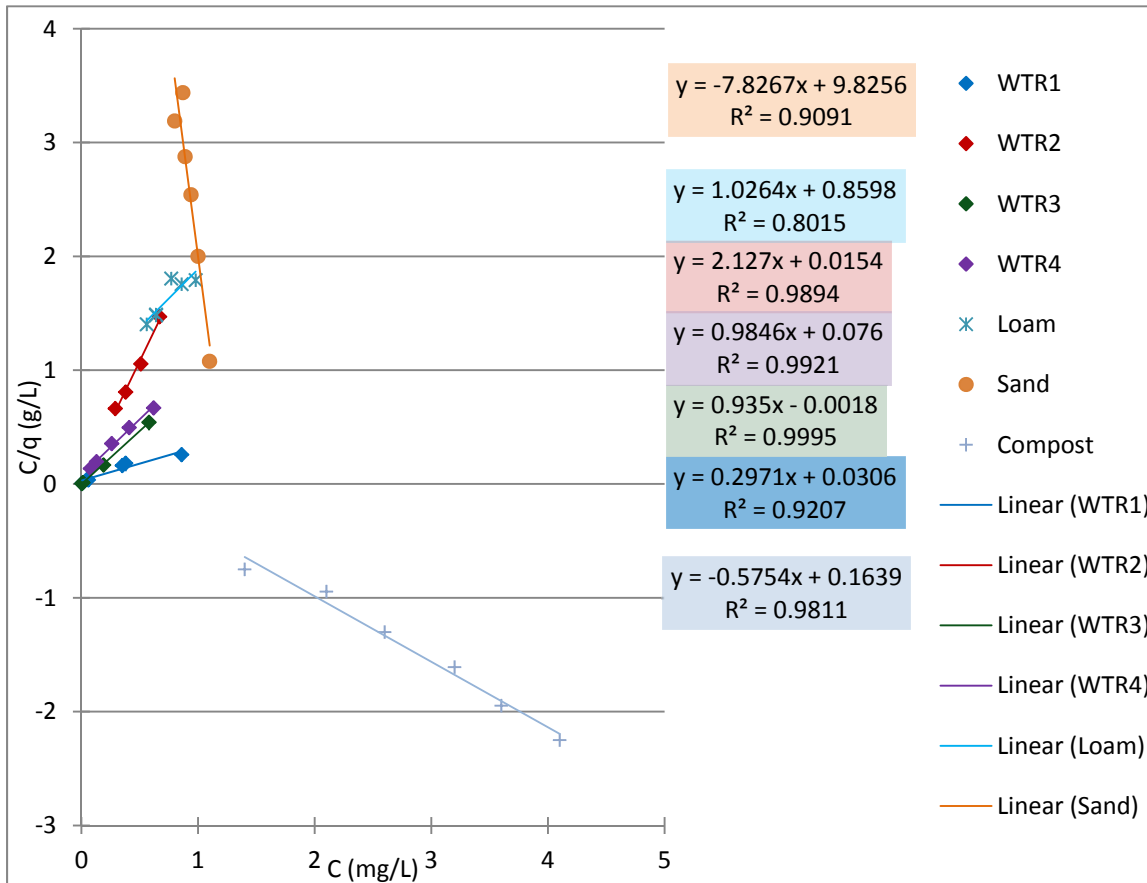


Figure 19. Langmuir Isotherm Model for Constituents

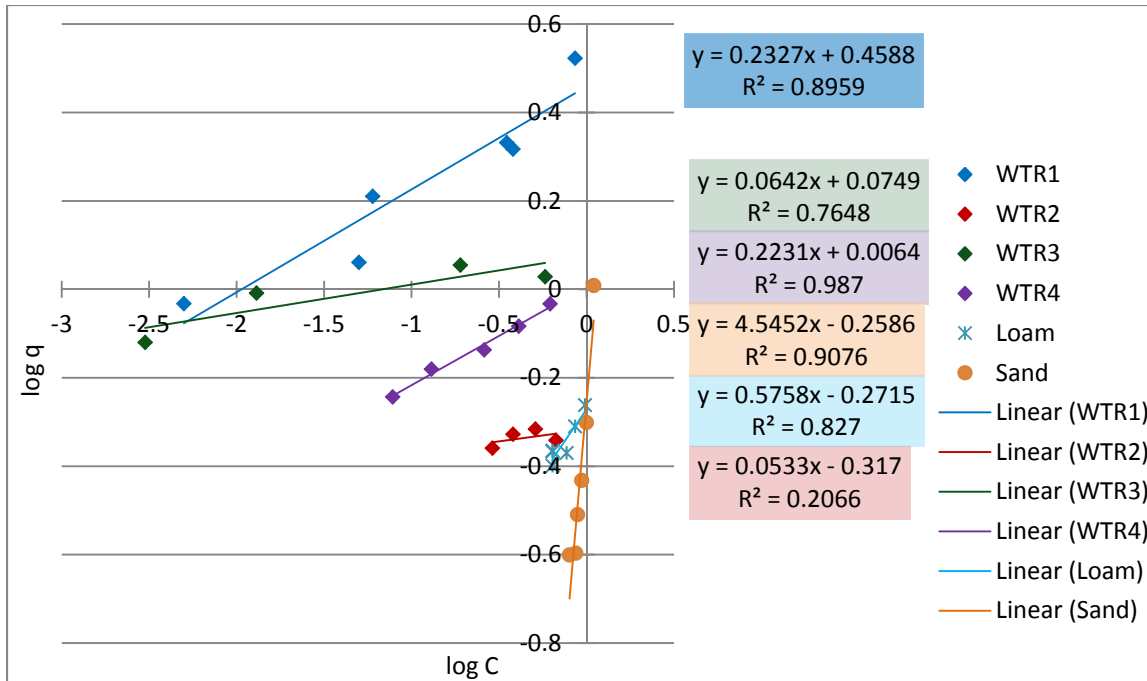


Figure 20. Freundlich Isotherm Model for Constituents

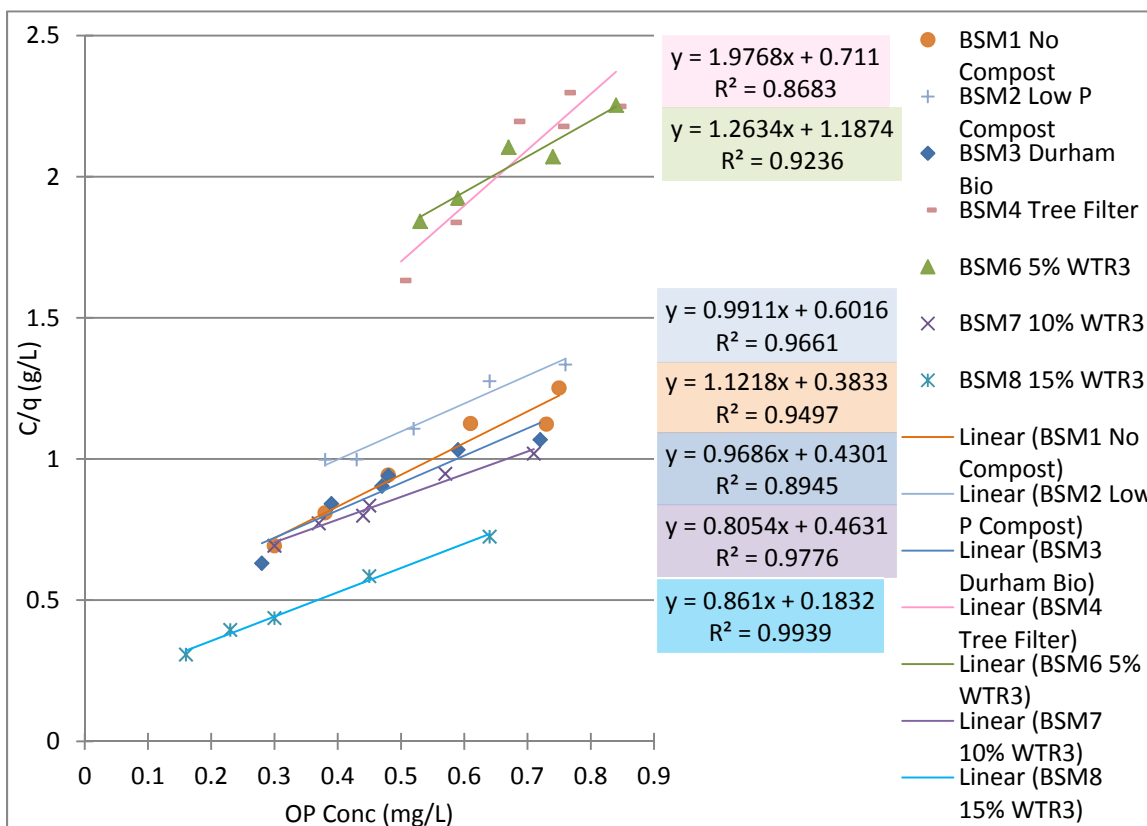
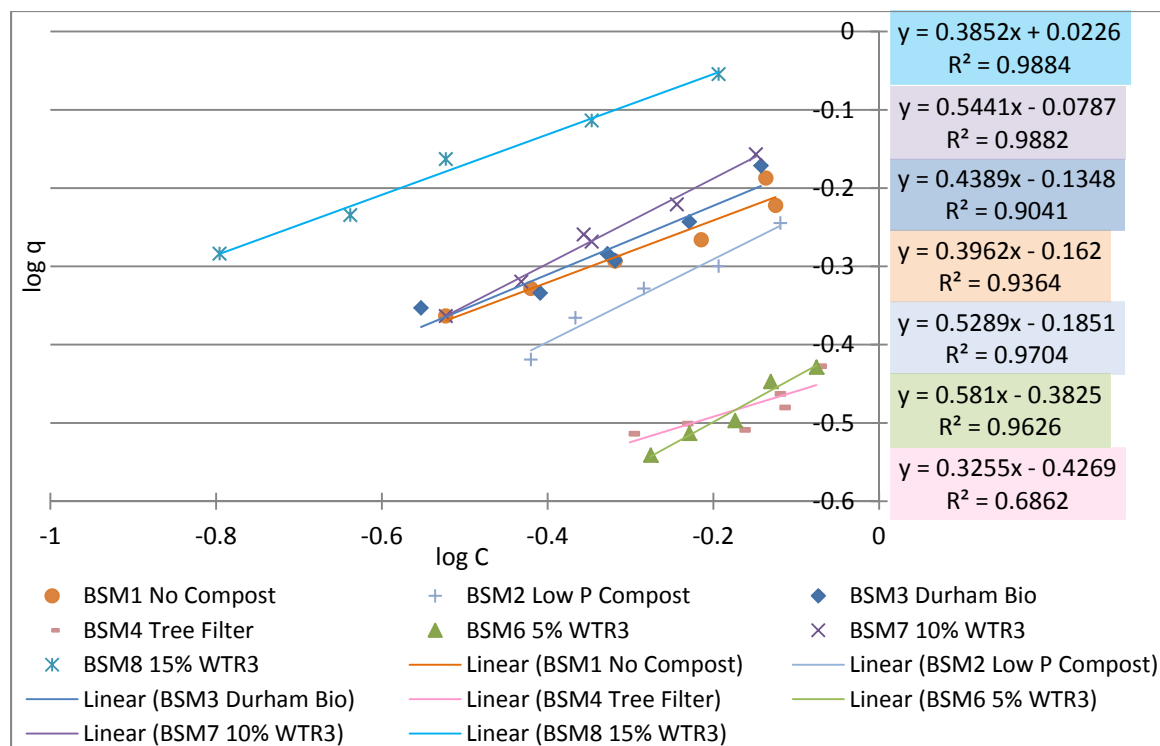


Figure 21. Langmuir Isotherm Model for BSMs



**Figure 22. Freundlich Isotherm Model for BSMs**

Linear regression analyses according to the Freundlich model are presented in Figure 20 and Figure 22 for BSM constituents and BSMs, respectively. This linearized model plots the log of the equilibrium OP concentration (C, mg/L) against the log of the equilibrium solid phase concentration (q, mg OP/g adsorbent). Compost1 is not included in this analysis because the P leaching causes negative q values, and it is not possible to take the log of those values. R<sup>2</sup> values for these linear regressions are generally very good as well, with some exceptions (0.2 for WTR2 and 0.69 for the Tree Filter mix).

The purpose of these linear regressions is to determine the Langmuir and Freundlich model parameters (see Table 6 and Table 7). These parameters can then be used to predict P sorption by materials at a given concentration; the predicted sorption is known as the solid phase equilibrium concentration in mg P/g material, denoted as q. The parameters derived from the linear regressions by the Langmuir model are the maximum adsorbent-phase concentration of OP when surface sites are saturated with OP (Q<sub>M</sub>) and the Langmuir adsorption constant of OP (b). The Q<sub>M</sub> is also sometimes reported as P<sub>max</sub> and may serve as the PSC for a material. The P<sub>max</sub> is related to the slope of the linearized Langmuir model (P<sub>max</sub> = 1/slope). However, the particular sorption at a given concentration is better represented by the solid phase concentration q, as calculated by the Langmuir model equation (see Equation 8). Table 6 presents not only the Langmuir model parameters, but the calculated q for the OP concentrations used in the short-term phase 3 column study experiment (0.2 mg/L) and the long-term phase 3 column study experiment and isotherm experiments (1.0 mg/L).

The Freundlich model parameters presented in Table 7 are the Freundlich adsorption capacity parameter (K) and the Freundlich adsorption intensity parameter (1/n). The solid phase

concentration  $q$ , as calculated by the Freundlich model equation (Equation 10), is also presented at the same concentrations as the Langmuir model. With the variation of the intensity parameter, the use of the  $K$  values is limited (Dayton et al. 2003). For example, WTR1 and WTR4 have similar  $n$  values, as do WTR2 and WTR3. From this, we can expect that WTR4 will sorb more P than WTR1, and WTR3 more than WTR2, based on their  $K$  values. This seems to be confirmed by the predicted sorption at a concentration of 0.2 mg/L ( $q_{0.2}$ ), but at a greater concentration, the predicted sorption of WTR1 and WTR4 is the same ( $q_{1.0}$ ). Further, the variation in  $n$  values between the two pairs of WTR limits a comparison between those two groups using the Freundlich model.

If we compare the  $Q_M$  (or  $P_{max}$ ) values from the Langmuir model with the two predicted sorption values ( $q_{0.2}$  and  $q_{1.0}$ ), there is greater consistency than in the Freundlich model. The order of WTR by  $P_{max}$  is  $WTR1 \gg WTR3 > WTR4 > WTR2$ . Measures of loam PSC are rather inconsistent. While loam has a fairly high  $P_{max}$ , its low adsorption constant ( $b$ ) contributes to inconsistent prediction of sorption at the high and low concentrations. While the Langmuir model is less sensitive to changes in  $b$  as is the Freundlich model to changes in  $1/n$ , the  $b$  value is not inconsequential. Sorption may vary at high and low concentrations, particularly for those materials with a lower baseline PSC, such as loam and each of the BSMs when compared to straight WTRs.

**Table 6. Langmuir Isotherm Model Parameters.**

The  $q$  represents equilibrium solid phase concentration, calculated with Equation 6 at a starting liquid phase concentration of  $C_A$ .

<b>Langmuir Parameters</b>							
<b>Material</b>	<b>Description</b>	<b>slope</b>	<b>intercept</b>	<b><math>Q_M</math> (mg P/g)</b>	<b>C (mg/L)=</b>	<b>0.2</b>	<b>1.0</b>
					<b>b (L/mg P)</b>	<b><math>q_{0.2}</math> (mg P/g)</b>	<b><math>q_{1.0}</math> (mg P/g)</b>
WTR1	indoor freeze/thaw	0.297	0.0306	3.37	9.72	2.22	3.05
WTR2	outdoor air-dried, aged	2.13	0.0154	0.470	138	0.454	0.467
WTR3	fresh, oven-dried	0.935	0.00100	1.07	935	1.06	1.07
WTR4	outdoor freeze/thaw	0.985	0.0760	1.02	13.0	0.733	0.943
Loam	NH commercial	1.03	0.860	0.974	1.19	0.188	0.530
Sand		-7.83	9.83	-0.128	-0.797	0.0242	0.500
Compost1	NH food & yard	-0.58	0.164	-1.74	-3.51	4.10	-2.43
Compost2	MA leaf & yard	N/A	N/A	N/A	N/A	N/A	N/A
Wood Chips		N/A	N/A	N/A	N/A	N/A	N/A
BSM1	No Compost BSM	1.12	0.383	0.891	2.93	0.329	0.664
BSM2	Low P Compost BSM	0.991	0.602	1.01	1.65	0.250	0.628
BSM3	Durham Bio (BSM w/10% WTR2)	0.969	0.430	1.03	2.25	0.321	0.715
BSM4	Tree Filter Mix w/ 10% WTR3	1.98	0.711	0.506	2.78	0.181	0.372
BSM5	Control (No WTR)	N/A	N/A	0.00	N/A	N/A	N/A
BSM6	BSM w/5% WTR3	1.26	1.19	0.79	1.06	0.139	0.408
BSM7	BSM w/10% WTR3	0.805	0.463	1.24	1.74	0.320	0.788
BSM8	BSM w/15% WTR3	0.861	0.183	1.16	4.70	0.563	0.958

**Table 7. Freundlich Isotherm Model Parameters.**

The  $q$  represents equilibrium solid phase concentration, calculated with Equation 8 at a starting liquid phase concentration of  $C_A$ .

<b>Freundlich Parameters</b>							
<b>Material</b>	<b>Description</b>	<b>slope</b>	<b>intercept</b>	<b>K</b>	<b>1/n</b>	<b>C (mg/L)=</b>	
						<b>0.2</b>	<b>1.0</b>
						<b>q<sub>0.2</sub></b> <b>(mg P/g)</b>	<b>q<sub>1.0</sub></b> <b>(mg P/g)</b>
WTR1	indoor freeze/thaw	0.233	0.459	2.88	0.233	1.98	2.88
WTR2	sun-baked	0.053	-0.317	0.482	0.0533	0.442	0.482
WTR3	fresh, soupy	0.064	0.0749	1.19	0.0642	1.07	1.19
WTR4	outdoor freeze/thaw	0.223	0.00637	1.01	0.223	0.709	1.01
Loam	NH commercial	0.576	-0.272	0.535	0.576	0.212	0.535
Sand		4.55	-0.259	0.551	4.55	3.67E-04	0.551
Compost1	NH food & yard	N/A	N/A	N/A	N/A	N/A	N/A
Compost2	MA leaf & yard	N/A	N/A	N/A	N/A	N/A	N/A
Wood Chips		N/A	N/A	N/A	N/A	N/A	N/A
BSM1	No Compost BSM	0.396	-0.162	0.689	0.396	0.364	0.689
BSM2	Low P Compost BSM	0.529	-0.185	0.653	0.529	0.279	0.653
BSM3	Durham Bio (BSM w/10% WTR2)	0.439	-0.135	0.733	0.439	0.362	0.733
BSM4	Tree Filter Mix w/ 10% WTR3	0.325	-0.427	0.374	0.325	0.222	0.374
BSM5	Control (No WTR)	N/A	N/A	N/A	N/A	N/A	N/A
BSM6	BSM w/5% WTR3	0.581	-0.383	0.414	0.581	0.163	0.414
BSM7	BSM w/10% WTR3	0.544	-0.079	0.834	0.544	0.347	0.834
BSM8	BSM w/15% WTR3	0.385	0.0226	1.05	0.385	0.567	1.05

Because we have isotherm data for the components as well as the BSMs themselves, we have the ability to calculate BSM isotherm parameters from the component results and compare those to measured BSM results. We do this by weighting the contributions of each of the components appropriately. For instance, the calculated adsorption rate of a BSM at a given concentration of 1 mgP/L,  $q_{calc}$ , is found with the following equation:

$$q_{calc} = \sum_{i=1}^n \frac{q_i \times \rho_i \times \%S_i \times \%V_i}{\rho_{BSM} \times \%S_{BSM}}$$

**Equation 20. Calculated Adsorption Rate**

where  $q_i$  = component  $q$  (mgP/g dry material) at a given concentration of 1 mgP/L;  $\rho_i$  and  $\rho_{BSM}$  = density of component and BSM, respectively (g wet material/mL);  $\%S_i$  and  $\%S_{BSM}$  = % solids of component and BSM, respectively (g dry material/g wet material);  $\%V_i$  = % volume of component in mix (mL wet component/mL wet BSM). Calculated and measured phosphorus sorption capacities (PSCs) are presented in Table 8 and Table 9, with BSMs ordered based on the

measured  $q_{1.0}$  PSC value. These tables demonstrate that Langmuir and Freundlich models predict the same relative sorptive capacities for the eight BSMs used in this study. In nearly all cases, the calculated PSCs underpredict the sorptive capacity of the BSM, while also failing to predict an accurate relative PSC (e.g., according to the measured  $q_{1.0}$ , the BSM containing no compost has one of the highest PSCs, though when measured, it falls behind the other BSMs with 10 and 15% WTR).

One reason for the lack of reliability in the calculated values is likely missing data. Due to logistics, isotherms were not run on wood chips, which likely contribute to PSC (O'Neill and Davis 2012a). In the absence of a value, their assumed contribution to the BSM PSC is zero. This may partially explain why the calculated  $q_{1.0}$  values for most mixes underestimate the measured  $q_{1.0}$  value. The calculated  $q_{1.0}$  value for the tree filter mix (BSM6), the only soil mix to contain no wood chips, is an exception. It may be expected that calculated values for this mix are more accurate since data is not missing for any of the mix components. Another potential reason for the disparity between measured and calculated PSC is the fact that some of the BSM materials crush more easily than others. For example, WTR, a main contributor to high PSC is very crushable, whereas sand is not. When crushing and sieving the pre-mixed BSMs for the isotherm experiments, it is possible that this difference in materials caused a significant shift in relative % volume component content within the mixes. Validation of the isotherm data is needed with further experiments to investigate the discrepancy between calculated component PSC and measured mix PSC.

**Table 8. Langmuir P sorption capacity, BSM ordered by the measured  $q_{1.0}$ .**

BSM	BSM Description	Composition (S/WC/L/C/WTR)	Measured		Calculated	
			$q_{1.0}$ (mg/g)	$P_{max}$ (mg/g)	$q_{1.0}$ (mg/g)	$P_{max}$ (mg/g)
BSM 8	BSM w/15% WTR3	50/20/10/5/15	0.9577	1.161	0.4246	0.0756
BSM 7	BSM w/10% WTR3	50/20/10/10/10	0.7884	1.242	0.4143	0.0620
BSM 3	Durham Bio (BSM w/10% WTR2)	50/20/10/10/10	0.7150	1.032	0.4225	0.0623
BSM 1	No Compost BSM	50/20/20/-/10	0.6644	0.891	0.4940	0.17
BSM 2	Low P Compost BSM	50/20/10/10/10	0.6279	1.009	0.4889	0.17
BSM 6	BSM w/5% WTR3	50/20/10/15/5	0.4080	0.792	0.4218	0.0497
BSM 4	Tree Filter Mix w/ 10% WTR3	80/-/-/10/10	0.3720	0.506	0.4658	-0.0170
BSM 5	Control (No WTR)	50/20/10/20/-	NA	NA	0.3893	0.0322



**Table 9. Freundlich P sorption capacity, BSM ordered by the measured  $q_{1.0}$ .**

BSM	BSM Description	Composition (S/WC/L/C/WTR)	Measured	Calculated
			$q_{1.0}$ (mg/g)	$q_{1.0}$ (mg/g)
BSM 8	BSM w/15% WTR3	50/20/10/5/15	1.0534	0.4839
BSM 7	BSM w/10% WTR3	50/20/10/10/10	0.8342	0.4935
BSM 3	Durham Bio (BSM w/10% WTR2)	50/20/10/10/10	0.7332	0.5031
BSM 1	No Compost BSM	50/20/20/-/10	0.6886	0.5360
BSM 2	Low P Compost BSM	50/20/10/10/10	0.6530	0.4850
BSM 6	BSM w/5% WTR3	50/20/10/15/5	0.4145	0.5265
BSM 4	Tree Filter Mix w/ 10% WTR3	80/-/-/10/10	0.3742	0.5447
BSM 5	Control (No WTR)	50/20/10/20/-	0.0000	0.5105

As mentioned before, the Langmuir  $P_{max}$  parameter is commonly used as a maximum PSC, a property of materials describing their ability to sorb P and useful for making comparisons. Table 10 presents the  $P_{max}$  values of materials used in this study along with  $P_{max}$  values for numerous materials presented in literature. Durham WTR samples have some of the lowest PSCs among those listed. All pale in comparison to the very high  $P_{max}$  values of the WTR used in Novak and Watts (2004) studies. This suggests that evaluation of WTR for PSC is crucial prior to commercialization of WTR for use as a phosphorus sorbent. WTR1 appears to be reasonably good in comparison to those tested in the Dayton studies (Dayton and Basta 2005; Dayton et al. 2003), but the other three Durham WTRs are very much on the low end of the spectrum. The 0.30 mg/g PSC for Dayton Min represents the minimum  $P_{max}$  of the 21 WTR samples tested in the Dayton et al. 2003 study. Comparing soil blends that contain WTR as an amendment, the BSMs in our study again have a comparatively low  $P_{max}$ , seeming to be more on par with unamended soils in the other studies. The median  $P_{max}$  of the BSMs used in the present study is 1.01 mg/g, whereas the literature indicates a median  $P_{max}$  for unamended soils of around 1 mg/g, and 5.5 mg/g for WTR-amended soils.

In general, the  $Al_{ox}$  or  $Al_{Meh}$  content appears to correlate fairly well with  $P_{max}$  values, at least in terms of the vast differences in orders of magnitudes. Table 10 reports  $Al_{Meh}$  for materials used in the present study and  $Al_{ox}$  for all materials from literature, since both of these measure reactive Al, which is expected to be a good indicator of PSC (Dayton and Basta 2005; Dayton et al. 2003; Sakadevan and Bavor 1998). For instance, the Novak and Watts (2004) WTR have  $P_{max}$  values an order of magnitude greater than any other WTR reported, as well as over 100,000 mg/kg  $Al_{ox}$  content. The only other WTR to match this  $Al_{ox}$  content is the O'Neill WTR, for which  $P_{max}$  is not reported. As with the  $P_{max}$  values, the Durham WTR compare best with the Dayton et al. (2003) WTR in terms of reactive aluminum as well.

**Table 10. Table of  $P_{max}$  values of project materials and others from literature.**

	<b>Material</b>	<b>Description</b>	<b><math>P_{max}</math> (mg/g)</b>	<b><math>Al_{ox}</math> or <math>Al_{Meh}</math> (mg/kg)</b>
*	WTR1	frozen, decanted (Durham Feb 2011)	3.37	2001
*	WTR2	dried, cracked (Durham Summer 2011)	0.47	1588
*	WTR3	wet (Durham Fall 2011)	1.07	2050
*	WTR4	freeze/thaw in dumpster (Durham Spr 2012)	1.02	2330
	Loam	from LandCare (Dover Feb 2011)	0.97	1291
	Sand	Alumni Center sand (Feb 2011)	-0.13	619
	Compost1	food and yard waste (NH Feb 2011)	-1.74	408
	Compost2	yard and leaf waste (MA Spr 2012)	n/a	448
	Wood Chips		n/a	
#	BSM1	No Compost (50/20/20/-/10)	0.89	
#	BSM2	Low P Compost (50/20/10/10/10)	1.01	
#	BSM3	Durham Bio (50/20/10/10/10)	1.03	1292
#	BSM4	Tree Filter (80/-/10/10)	0.51	
	BSM5	Control (50/20/20/10/-)	0.00	
#	BSM6	5% WTR3 (50/20/10/15/5)	0.79	
#	BSM7	10% WTR3 (50/20/10/10/10)	1.24	
#	BSM8	15% WTR3 (50/20/10/5/15)	1.16	
*	Novak G1 <sup>a</sup>	alum WTR from NC, June 2001	175	113000
*	Novak G2 <sup>a</sup>	alum WTR from NC, Apr 2002	85	145000
*	D&B-I (<2mm fraction) <sup>b</sup>	mean value for initial WTR	3.93	54500
*	D&B-C(<150 $\mu$ m fraction) <sup>b</sup>	mean value for crushed WTR	9.68	73100
*	Dayton Min <sup>c</sup>	minimum of 21 WTR	0.30	1330
*	Dayton Max <sup>c</sup>	maximum of 21 WTR	5.14	4870
*	O'Neill & Davis WTR <sup>d</sup>	Al-based WTR		155000
#	Novak Aut+5% G1 <sup>a</sup>	NC soil amended w/5% G1 WTR	5.1	
#	Novak Aut+10% G1 <sup>a</sup>	NC soil amended w/10% G1 WTR	8.5	
#	Novak Aut+5% G2 <sup>a</sup>	NC soil amended w/5% G2 WTR	2.6	
#	Novak Aut+10% G2 <sup>a</sup>	NC soil amended w/10% G2 WTR	6.9	
#	Novak Nor+5% G1 <sup>a</sup>	SC soil amended w/5% G1 WTR	5.0	
#	Novak Nor+10% G1 <sup>a</sup>	SC soil amended w/10% G1 WTR	8.3	
#	Novak Nor+5% G2 <sup>a</sup>	SC soil amended w/5% G2 WTR	4.1	
#	Novak Nor+10% G2 <sup>a</sup>	SC soil amended w/10% G2 WTR	5.8	
†	O'Neill & Davis BSM <sup>d</sup>	unamended commercial BSM		286
†	Novak Autry Soil <sup>a</sup>	acidic (pH=4.3) NC Coastal Plain soil	0.585	840
†	Novak Norfolk Soil <sup>a</sup>	acidic (pH=4.7) SC Coastal Plain soil	0.80	640
†	S&B RTS <sup>e</sup>	Richmond Top Soil (Sydney, NSW)	1.153	770
†	S&B RSS <sup>e</sup>	Richmond SubSoil (Sydney, NSW)	1.727	1200
	S&B BBU2 <sup>e</sup>	wetland soil, Byron Bay Unit 2	4.237	5510
	S&B BBU3 <sup>e</sup>	wetland soil, Byron Bay Unit 3	5.208	4550
	S&B BBO <sup>e</sup>	wetland soil, Byron Bay Original	4.484	4620

	S&B Carcoar <sup>e</sup>	topsoil for wetland system	0.934	1320
+	S&B BFS <sup>e</sup>	blast furnace slag	44.247	
+	S&B SFS <sup>e</sup>	steel furnace slag	1.430	
+	S&B Zeolite <sup>e</sup>	zeolite (alumino silicate)	2.150	
+	S&Ma AOCM <sup>f</sup>	aluminum oxide coated media	2.52	
* WTR		<sup>a</sup> Novak and Watts 2004		
# Mix containing WTR		<sup>b</sup> Dayton and Basta 2005		
+ Alternative amendments		<sup>c</sup> Dayton et al. 2003		
† Unamended soil		<sup>d</sup> O'Neill and Davis 2012a		
		<sup>e</sup> Sakadevan and Bavor 1998		
		<sup>f</sup> Sansalone and Ma 2011		

## Isotherm Model Statistical Analysis

The Langmuir and Freundlich isotherm models were assessed using Wilmott's (1982) methods, as described in the methods section. While each have been used to describe phosphorus adsorption in literature, these methods provide a statistical means of assessing the models' fit of the isotherm data with respect to the equilibrium solid phase concentration,  $q$  (mg/g). The first four rows in Table 11 (both a and b) involve the comparison of the means ( $mean_O$  and  $mean_M$ ) and standard deviation ( $S_O$  and  $S_M$ ), of the observed and modeled  $q$  values, respectively. The Langmuir and Freundlich modeled mean  $q$  values of soil mix components (0.824 and 0.836 mg/g) compare very well to the actual mean of observed values (0.845 mg/g). Standard deviations also compare well, with Langmuir slightly overpredicting (0.70) and Freundlich slightly underpredicting (0.62) the standard deviation of observed data (0.67). Means and standard deviations of BSM observed and modeled data are practically identical, indicating a very good model fit (Table 11b).

**Table 11. Statistical Model Assessment Measures of observed values and values modeled by Langmuir and Freundlich isotherm models for (a) soil mix components and (b) BSMs.**

<b>(a) Soil Mix Component Analysis</b>			<b>(b) BSM Analysis</b>		
	<b>Langmuir</b>	<b>Freundlich</b>		<b>Langmuir</b>	<b>Freundlich</b>
mean <sub>O</sub>	0.845	0.845	mean <sub>O</sub>	0.490	0.490
mean <sub>M</sub>	0.824	0.836	mean <sub>M</sub>	0.489	0.490
S <sub>O</sub>	0.665	0.665	S <sub>O</sub>	0.140	0.140
S <sub>M</sub>	0.703	0.624	S <sub>M</sub>	0.140	0.139
N	31	31	N	39	39
a	-0.0252	0.0593	a	0.0035	0.0068
b	1.005	0.919	b	0.992	0.986
MAE	0.103	0.0733	MAE	0.0141	0.0114
RMSE	0.214	0.132	RMSE	0.0175	0.0152
RMSE <sub>S</sub>	0.0215	0.0538	RMSE <sub>S</sub>	0.0012	0.0020
RMSE <sub>U</sub>	0.213	0.120	RMSE <sub>U</sub>	0.0175	0.0150
d	0.920	0.972	d	0.974	0.980
R <sup>2</sup>	0.90	0.96	R <sup>2</sup>	0.98	0.99
N-S Eff	0.97	0.99	N-S Eff	0.73	0.80

The N value on the next row merely indicates the number of data points for each analyses, on which was performed a linear regression. A good fit model will approximate a 1:1 line, with intercept (a) of 0 and slope (b) of 1. Again, both models perform well on this test, particularly for the BSM analysis. The Langmuir has a slightly closer 1:1 approximation than the Freundlich for the soil mix analysis. Here it is also helpful to see a visual representation of the data plotted with observed values on the x-axis and predicted values on the y-axis (see Figure 23). From this vantage point, all data appears to approximate the 1:1 line remarkably well. It is notable that WTR1, with the highest q values has the greatest departure from the 1:1 line, particularly in the Langmuir model. All of the BSM observed and modeled values are <1 mg/g, and present very little departure from the 1:1 line.

The difference between observed and modeled values is described by the mean absolute error (MAE) and the root mean square error (RMSE). The MAE is often lower, because it is less sensitive to extreme values (Willmott 1982). The difference measures are low, indicating good fit for both models, particularly with respect to the BSM analysis. The systematic RMSE is expected to be very near 0, while the unsystematic RMSE should approach the RMSE, indicating

that the model accurately reflects the trends of the data (i.e., most of the error in the data is random and not caused by a systematic trend). This is the case again for both models.

The measures of agreement between the observed and predicted values include the index of agreement (d), the squared correlation coefficient ( $R^2$ ), and the Nash-Sutcliffe efficiency (N-S Eff). For each of these measures, a value of 1 indicates perfect agreement. Although the Langmuir measures are consistently somewhat lower than the Freundlich measures, the fact that most of these measures are  $\geq 0.90$  confirms that both the Langmuir and Freundlich models acceptably fit the data representing the equilibrium solid phase concentration of orthophosphate, q (mg P/g). It is a bit surprising that the Nash-Sutcliffe efficiency is much lower for both models of the BSMs (0.73 and 0.80 for Langmuir and Freundlich, respectively) than for the soil mix components (0.97 and 0.99, respectively); however, they still indicate fairly good agreement between observed and modeled values.

As stated earlier, the literature, like the statistical data just presented, is unclear on a choice between the Langmuir and Freundlich linear models for phosphorus adsorption. This data may be used to support the use of either model. While the Freundlich model should not be ignored, the Langmuir model contains useful terms for prediction of column and field performance of materials. Therefore, the Langmuir model was the focus for further analysis by comparison with column study data and field data.

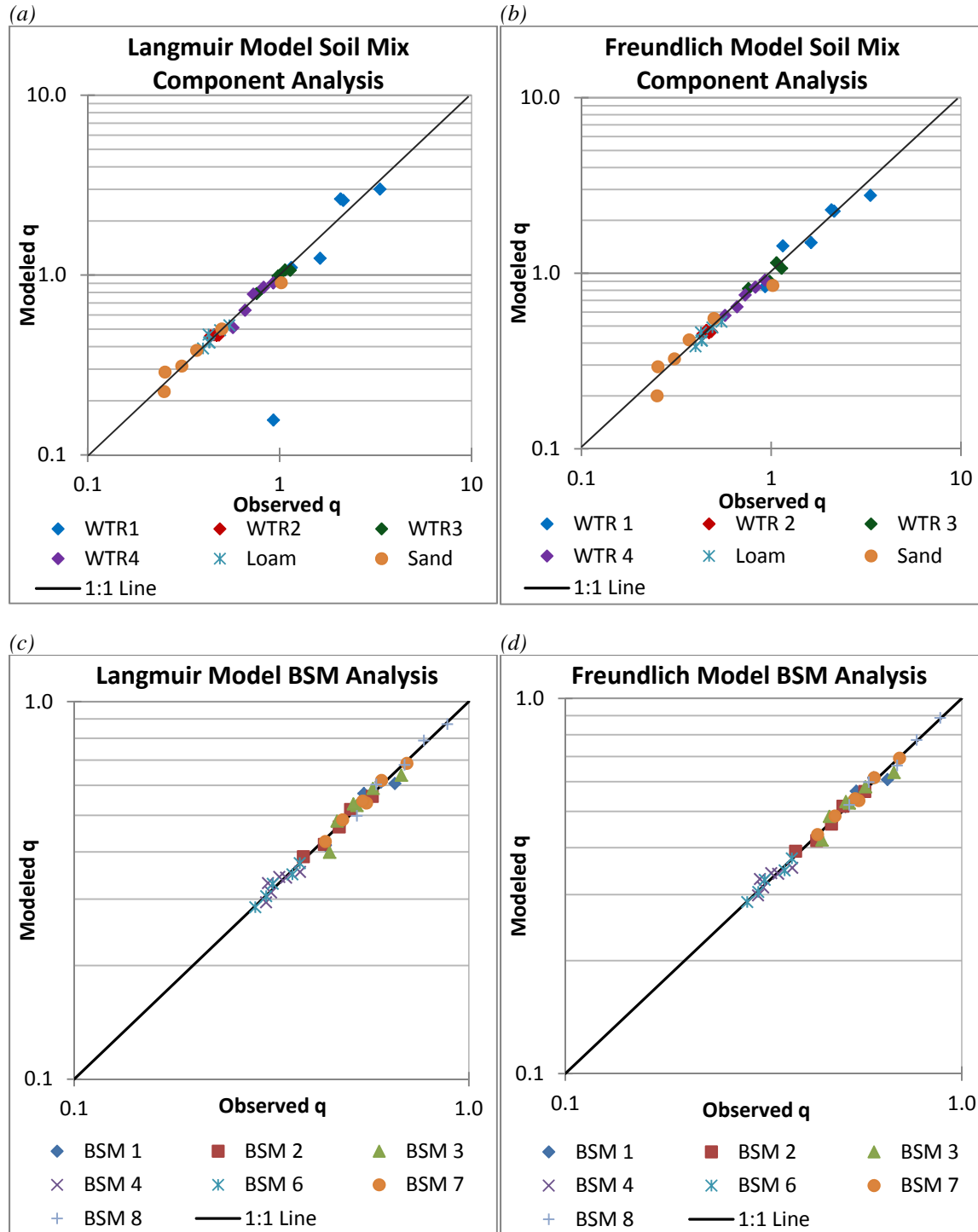


Figure 23. Isotherm Model Assessment: Linear Regression of Observed vs. Modeled  $q$  (mg/g).

## Column Study Results

The purpose of column studies was to provide a bench scale test of phosphorus adsorption of materials mixed at field moisture. Infiltration rates and contact time in columns was examined along with the column contents to assess their impact on water quality improvement through filtration in columns.

### Column Media Infiltration Rates and Contact Times

Infiltration rates of the soil media in columns varied widely during the experiments, between different BSMs as well as with time and even between duplicate columns containing identical BSMs. Since the columns were gravity fed, the infiltration rate of the soil media determined the contact time between the influent and the media. Contact time is an important factor in adsorption of OP, as demonstrated in kinetics studies (see Figure 16). Figure 24 provides a snapshot of the variation in infiltration rates between column study phases, between soil mixes, and in time (see Appendix C for data tables). These infiltration rates are averages, based on the total volume for a single event over the total time for the volume to filter through the column. As often observed in the field, infiltration rates tended to reduce with time as the filter media layer becomes compacted by the constant ponding of water. In the field, this can be exacerbated by accumulation of fines upon the filter surfaces, the system being walked upon, piled with snow, etc. Vegetation may alleviate some of the issue due to root structures. Another suspected cause of decreased infiltration rates over extended periods of time in the field is the break down of wood chips, which add structure and porosity to the soil mix, as well as organic content to support plant growth over the long term as they slowly break down.

Prior to each phase of column experiments, clean water (from the RO system at UNH) was run through each of the columns to allow the media to settle and to wash out finer sediments. These RO runs are presented in Figure 24 for phase 3 only, as data is unavailable for phases 1 and 2. Infiltration rates tend to become more consistent after the initial very fast runs, though for some mixes the downward trend continues (notably, BSM1, BSM3, and BSM5). BSM3 from the phase 3 column study experiences an approximately 70% drop in infiltration rate from the start of RO runs (490 in/hr) to the start of experimental runs (158 in/hr), which is fairly consistent with the other mixes. However, a second drastic drop of nearly 80% between the first and third experimental runs causes a large difference between infiltration rates of this column and its duplicate (BSM3D) in the later runs. The top and bottom of the BSM3 column were investigated for a blockage that could be removed but none was found. Clogging must have occurred within the 2 foot height of media.

The clogged BSM3 column actually reduces the infiltration rates nearer to the order of the phase 1 columns, which had drastically lower infiltration rates than the phase 2 and 3 column studies. These rates are actually closer to those expected in bioretention systems, which experience compaction as mentioned above and often include outlet controls to reduce hydrologic impacts of development and increase contact times. While most of the phase 2 and 3 columns could drain a 6 inch simulated storm in a few hours, phase 1 columns generally drained 6-7 inch simulated storms in closer to 24 hours (a typical design draindown time for bioretention systems). The much higher solids content of WTR1 (33% solid, as compared to 5-10% in raw

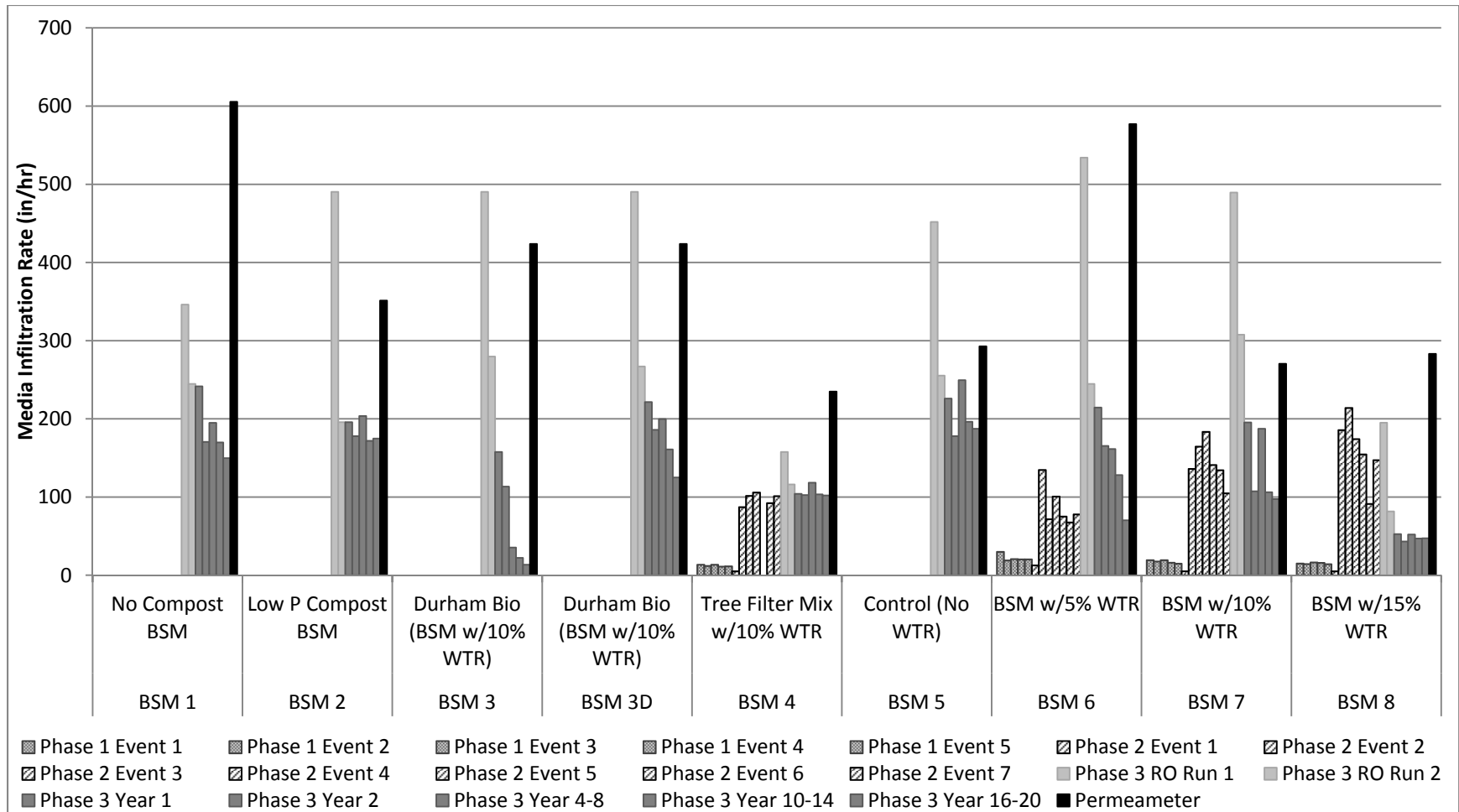
WTR samples 2 and 3) in phase 1 columns likely contributes to the slower infiltration rates in those columns. It was hypothesized that the effectiveness of the treatment in phase 2 and 3 columns would be reduced due to lower WTR solids content as well as the reduced contact time, as a function of infiltration rate:

$$EBCT = \frac{BV}{Q}$$

**Equation 21. Empty Bed Contact Time**

where EBCT = empty bed contact time (min), BV = empty bed volumes (unitless volume measure based on 2 feet of media in each column), and Q = flow rate or infiltration rate (mL/min). Due to the reduction in infiltration rate of the BSM3 column, the median EBCT was 41 minutes, as compared to the EBCT of BSM3D column of 8 minutes.





**Figure 24. Infiltration Rates of filter media (BSMs) used in each column study phase and permeameter tests.**  
*RO runs indicate runs with clean water (ROwater) prior to the start of the experiment.*

**Table 12. Infiltration Rates and Empty Bed Contact Times (EBCT) of all column media.**

<b>Name</b>	<b>Description</b>	<b>Median Infiltration Rate (in/hr)</b>	<b>Median EBCT (min)</b>
<b>Phase 1</b>	<b>All phase 1 measurements</b>	<b>16</b>	<b>77</b>
BSM.05	BSM w/5% WTR1	20	61
BSM.10	BSM w/10% WTR1	17	71
BSM.15	BSM w/15% WTR1	15	83
TF.05	Tree Filter Mix w/5% WTR	12	104
<b>Phase 2</b>	<b>All phase 2 measurements</b>	<b>109</b>	<b>14</b>
BSM.05-1	BSM w/5% WTR2	75	19
BSM.05-2	BSM w/5% WTR2	121	12
BSM.10-1	BSM w/10% WTR2	136	11
BSM.10-2	BSM w/10% WTR2	88	16
BSM.15-1	BSM w/15% WTR2	155	9
BSM.15-2	BSM w/15% WTR2	185	8
TF.10-1	Tree Filter Mix w/10% WTR2	97	15
TF.10-2	Tree Filter Mix w/10% WTR2	97	15
<b>Phase 3</b>	<b>All phase 3 measurements</b>	<b>187</b>	<b>9</b>
BSM 1	No Compost BSM w/10% WTR3	195	8
BSM 2	Low P Compost BSM w/10% WTR3	196	8
BSM 3	Durham Bio (BSM w/10% WTR2)	113	41
BSM 3D	Durham Bio (BSM w/10% WTR2)	113	8
BSM 4	Tree Filter Mix w/10% WTR3	200	14
BSM 5	Control (No WTR)	104	7
BSM 6	BSM w/5% WTR3	226	9
BSM 7	BSM w/10% WTR3	165	13
BSM 8	BSM w/15% WTR3	187	30

## Column Water Quality Performance

Accelerated nutrient loading of columns with natural runoff spiked with nitrate and phosphate generally yielded very good removal rates of orthophosphate (OP) and minimal removal rates of nitrate. Among three phases of column studies, the only column to leach OP was the one column which contained no WTR (BSM5 Control: 50% sand, 20% wood chips, 20% compost, 10% loam), strong evidence that WTR is a key component in the bioretention filter media.

Nitrate sampling was included in phases 1 and 2 but not in phase 3, because nitrate removal was not a focus of filter media selection. Some nitrate removal was observed, but the variation between mixes for nitrate removal was very small. Median nitrate removals were all below 10%. The range of nitrate influent concentrations spanned 0.4 mg/L, while the range of effluent concentrations spanned 0.6 mg/L. This confirms the results of the early batch equilibrium studies, that also showed very little change to nitrate concentration from contact with BSM components.

As hypothesized above, phase 1 column performance with high solids WTR and extended contact times generally surpassed that of phases 2 and 3, as measured by removal efficiency:

$$\%RE = \left(1 - \frac{C_{EFF}}{C_{INF}}\right) \times 100$$

**Equation 22. Removal Efficiency**

where  $C_{INF}$  = influent concentration (mg/L) and  $C_{EFF}$  = effluent concentration (mg/L). However, phase 1 data is limited by the instruments used for orthophosphate analysis, which had a detection limit of 0.01 mg P/L. ARA, the lab used for these analyses, acquired equipment to reduce the detection limit prior to the later studies. Nearly all effluent samples in phase 1 registered below detection limit, indicating >99% removal efficiency of OP from the 1 mg P/L influent, an exceptional removal rate which proved nearly unattainable during phases 2 and 3 of column studies. In phase 1, the BSM containing 5% WTR (BSM.05: 50% sand, 20% wood chips, 10% loam, 15% compost, 5% WTR1) was the only BSM to yield effluent samples above the detection limit, compared to similar mixes containing 10% and 15% WTR and the tree filter mix (80% sand, 15% compost, 5% WTR1). Even those samples, however, represent an extremely high removal rate of 98%.

Phases 2 and 3 of column studies provided a broader comparison of mixes. Phase 2 tested mixes in duplicate similar to those used in phase 1, with the exception that raw WTR2 (9% solids) was used rather than processed WTR1 (33% solids). Phase 3 expanded the types of mixes studied to include one that contains no WTR (BSM5) as a control, one that contains no compost (BSM1), and one that contains an alternative leaf and yard waste compost that tested as having a reduced available P content (BSM2) in order to examine the effect of compost on OP removal performance. WTR samples used in phase 3 mixes were raw (5-9% solids).

**Annual Nutrient Loads**

Empty bed volumes are a useful way to determine when a filter media reaches breakthrough and to size up a pilot-scale filter to appropriate field size, based on a given media depth (in this case, 2 ft). The volume of media in each column is 695 mL, based on 2 feet of media in 1.5 inch inner diameter columns. The empty bed volumes represent the number of times an equivalent volume of water filters through the system. However, bed volumes do not take into consideration a systematic change in influent concentration, which occurred during the phase 3 column study in order to efficiently load columns with nutrients equivalent to a 20 year nutrient load. After two annual OP loads at approximately 0.2 mg P/L were delivered to the phase 3 columns, the influent concentration was increased to approximately 1 mg P/L. This allowed for efficient delivery of 20 years' worth of nutrient loading to the columns to test the long-term performance of the BSMs for OP removal. Due to this systematic change to influent concentration, it was determined that data would be more appropriately displayed and compared amongst column study phases if plotted according to the number of annual nutrient loads supplied to columns by the influent, rather than the hydraulic measure of bed volumes (Figures 25-26).

Annual nutrient load was determined based on expected field influent concentrations of 0.02 mg P/L of orthophosphate and 0.5 mg N/L of nitrate and the average annual precipitation in Durham of 46 inches, again assuming a drainage area to filter area ratio of 20 (National Climatic Data Center 2013). Concentrations were initially determined from the influent from the first few storms at the Durham bioretention system (Bio-5), and this value was confirmed by UNH

Stormwater Center influent data from monitoring that dates back to 2007, median of 0.02 mg P/L. Similarly, influent OP data in the SPU bioretention database has a median of 0.026 mg P/L (Roseen et al. 2013). Thus, the annual expected OP load by mass to columns was determined to be 0.53 mg OP, equivalent to an annual OP loading rate of 43 mg OP/ft<sup>2</sup> of filter area. The number of annual loads delivered to columns at each sample point were determined as follows:

$$\text{Annual OP Loads (years)} = \sum_{i=1}^n \frac{(V_i - V_{i-1}) \times C_i}{m_{ANN}}$$

**Equation 23. Annual OP Loads**

where  $V_i$  = volume of effluent (L) collected from column when sample  $i$  is taken,  $C_i$  = influent concentration (mg P/L), and  $m_{ANN} = 0.53$  mg = mass of OP (mg) expected to be delivered to a system annually, based on surface area of system (in this case, cross-sectional area of columns). Guidance from EPA indicates concentrations above 0.025 mg/L of dissolved phosphorus cause rapid eutrophication (USEPA Office of Water Regulations and Standards 1986). While the expected influent concentration is just below this concentration, it is desirable to reduce it as much as possible, especially if runoff ends up in a water body already impaired for nutrients (USEPA Office of Water Regulations and Standards 1986). Since influent concentrations in the column studies are 10 to 50 times higher than the expected influent concentration in the field, we focused our assessment on both removal efficiencies and effluent concentrations.

The phase 1 column study demonstrated the greatest performance with regards to OP removal, which may be attributed to the use of processed WTR (33% solids) and the resulting slower infiltration rates. Nearly all effluent samples from the phase 1 column study were below the detection limit of 0.01 mg/L for methods used to analyze those samples.

The phase 2 column study data shows that the tree filter mix is the only one to approximately match the performance of the phase 1 mixes (Figure 25). The tree filter mixes contain no loam, which has a fairly high PSC according to the batch equilibrium studies, and contain compost, which leaches phosphorus. The phase 3 tree filter mix, which is essentially the same mix as in phase 2 but with WTR3 rather than WTR2, also performed well and the contact time was nearly identical to phase 2 (Figure 26). This demonstrates that contact time of around 15 minutes appears to be sufficient to achieve excellent OP removal. With the exception of phase 2 mixes containing 15% WTR2, columns with EBCT < 10 minutes, appear to have reduced performance.

The performance of the 5% WTR2 duplicate mixes in phase 2 rapidly declined over the course of the experiment from around 90% removal to <50% after 45 annual nutrient loads, while the other mixes showed only minimal decline, all still above 80% removal after 45 annual nutrient loads. These performances are likely somewhat inflated due to the acceleration of nutrient load. Removal efficiency is often lower at lower influent concentrations, because less contaminant is available to be removed. In addition, the isotherm models indicate that in general the capacity for phosphorus adsorption is reduced at lower initial concentrations (compare  $q_{0.2}$  and  $q_{1.0}$  in Table 6 and Table 7). The 10-15% WTR mixes all perform very similarly in phase 2.

Phase 3 columns have variable performance, especially after the nutrient load is accelerated to approximately 1 mg P/L of orthophosphate. Clear outliers in BSM3D and BSM4 data were

removed, and the control mix containing no WTR (BSM5) is not included in this figure because it leached P (negative %RE) in all but a few samples with very low %RE. Trendlines in Figure 25 and Figure 26 show the rate of decline in performance over time for certain BSMs. Phase 2 columns containing 5% WTR2 rapidly decline in performance (Figure 25), while phase 3 columns containing 5% WTR3 had modest removals early on in the experiment, which moderately slope downwards throughout the experiment (Figure 26). The phase 3 Durham Bio mixes have only a very moderate downward slope, indicating greater longevity of treatment from the mix.

In phase 3, the Durham Bio duplicate mixes containing WTR2 are among the top performers, even outperforming the 15% WTR3 mix (BSM8). This seems to indicate that a drier WTR2 (9% solids, rather than 5% for WTR3) trumps the higher PSC of WTR3 ( $P_{max}$  of 1 mg P/g WTR3, rather than 0.5 mg P/g WTR2) when WTR are added to the BSM on a volumetric basis. WTR2 have approximately half the PSC and nearly double the dry mass of WTR3. Thus, one might expect the WTR2 mixes to perform equivalently to the WTR3 mixes, with the additional solids equivalently making up for the reduced PSC. However, the WTR2 mixes (BSM3 and BSM3D in phase 3; BSM.10-1 and 2 in phase 2) outperform their WTR3 counterparts (BSM7 in phase 3), even when the volume of WTR admixture is increased to 15% WTR3 (BSM8 in phase 3). Efficiency ratios of BSMs containing 10-15% WTR2 range from 88% to 94%, while their counterparts containing WTR3 range from 80% to 85% (Table 13). The downward trend of performance over the 20 year nutrient loading for WTR2 mixes is more moderate than any of the other trends in phase 3.

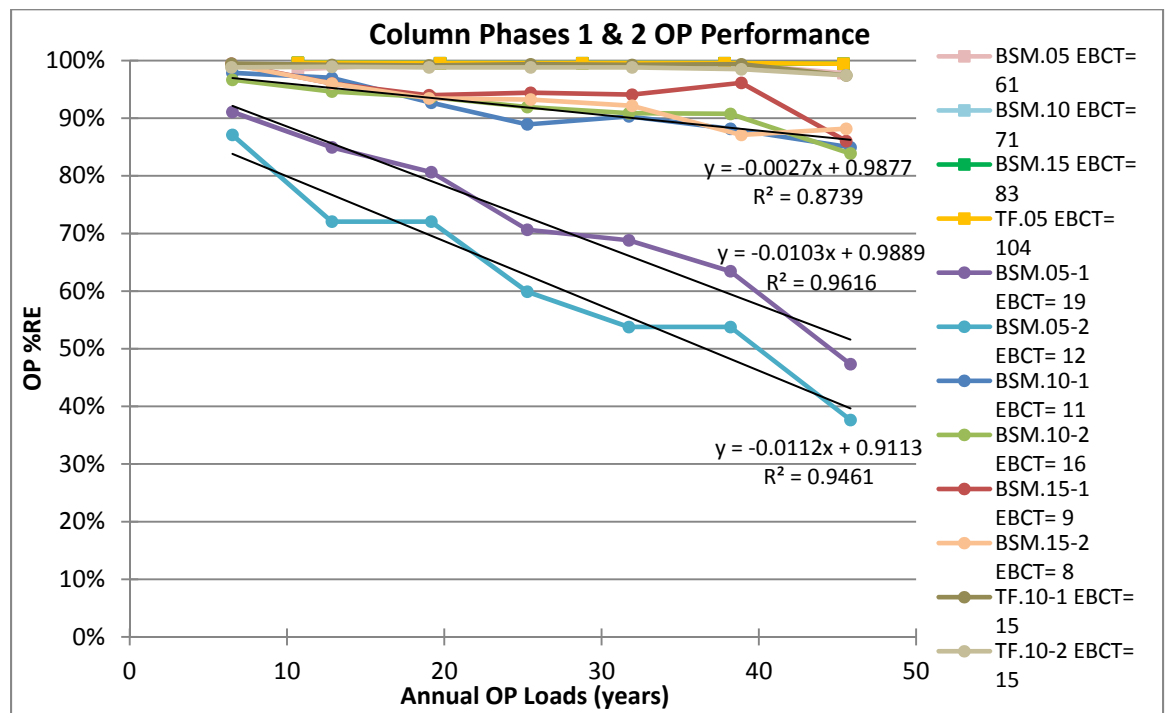


Figure 25. Phases 1 and 2 Column Removal Efficiencies based on annual nutrient loads of 43 mg OP/ft<sup>2</sup>. Square markers denote phase 1 columns; circle markers denote phase 2 columns.

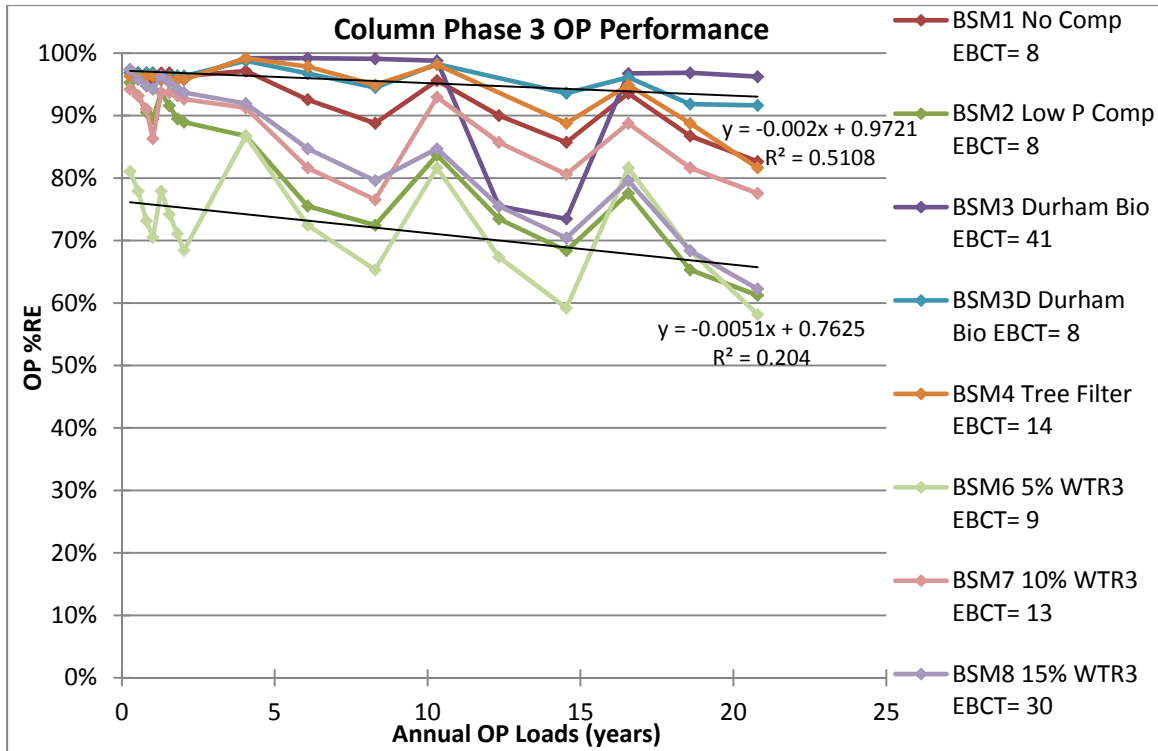


Figure 26. Phase 3 Column Removal Efficiencies based on annual nutrient loads of 43 mg OP/ft<sup>2</sup>.

### Empty Bed Contact Time effect on BSM performance

The 41 minute median contact time in the BSM3 column appears to produce a slight advantage over its duplicate column with median 8 minute EBCT. With the exception of a couple of samples, BSM3 removal efficiencies exceed those of BSM3D (Figure 26). The improvement is neither drastic nor consistent. BSM3D has consistently > 90% RE even at a much lower EBCT, although its efficiency ratio dips down to 88% (Table 13). The effect of EBCT on OP removal performance cannot be conclusively determined from these column studies due to confounding effects from other factors, particularly BSM composition. The fact that phase 1 columns had excellent removals and much higher contact times than columns in phases 2 and 3 indicates that EBCT > 1 hour may be optimal for OP removal. However, phase 1 columns also contained much higher WTR solids content than the other phases, which likely account at least in part for the elevated performance. The phase 2 tree filter mixes (TF.10-1 and TF.10-2) also achieve 99% removal rates at 15 minute contact times. These results seem to be in keeping with the recommendations of Pitt and Clark (2010) of a minimum contact time of 10 minutes.

**Table 13. Summary Statistics of all column study phases.**

	Name	Description	N	EBCT (min)	ER	OP %RE					Effluent OP Concentration						
						Med %RE	95% CI	Mean %RE	SD	CV	Med Eff C	95% CI	Mean Eff C	SD	CV		
Phase 1	BSM.05	BSM w/5% WTR	5	61	99.0%	99.5%	99.5%	98%	99%	0.01	0.01	0.005	0.005	0.02	0.011	0.01	0.67
	BSM.10	BSM w/10% WTR	5	71	99.5%	99.5%	N/A	N/A	99.5%	N/A	N/A	0.005	N/A	N/A	0.005	N/A	N/A
	BSM.15	BSM w/15% WTR	5	83	99.5%	99.5%	N/A	N/A	99.5%	N/A	N/A	0.005	N/A	N/A	0.005	N/A	N/A
	TF.05	Tree Filter Mix w/5% WTR	5	104	99.5%	99.5%	N/A	N/A	99.5%	N/A	N/A	0.005	N/A	N/A	0.005	N/A	N/A
Phase 2	BSM.05-1	BSM w/5% WTR	7	19	73%	71%	91%	47%	72%	0.14	0.19	0.273	0.083	0.490	0.257	0.13	0.49
	BSM.05-2	BSM w/5% WTR	7	12	63%	60%	87%	38%	62%	0.15	0.24	0.373	0.120	0.580	0.350	0.14	0.40
	BSM.10-1	BSM w/10% WTR	7	11	92%	90%	98%	85%	91%	0.04	0.05	0.090	0.020	0.140	0.080	0.04	0.51
	BSM.10-2	BSM w/10% WTR	7	16	92%	92%	97%	84%	92%	0.04	0.04	0.075	0.031	0.150	0.077	0.04	0.46
	BSM.15-1	BSM w/15% WTR	7	9	94%	94%	99%	86%	94%	0.04	0.04	0.052	0.005	0.130	0.053	0.04	0.67
	BSM.15-2	BSM w/15% WTR	7	8	93%	93%	99%	87%	93%	0.04	0.04	0.063	0.006	0.120	0.067	0.04	0.54
	TF.10-1	Tree Filter Mix w/10% WTR	7	15	99%	99%	99%	97%	99%	0.01	0.01	0.007	0.005	0.024	0.009	0.01	0.69
	TF.10-2	Tree Filter Mix w/10% WTR	7	15	99%	99%	99%	97%	99%	0.00	0.00	0.011	0.010	0.024	0.013	0.00	0.35
Phase 3	BSM 1	No Compost BSM (10% WTR3)	17	8	91%	95%	97%	90%	93%	0.05	0.05	0.028	0.007	0.098	0.054	0.05	1.02
	BSM 2	Low P Compost BSM	17	8	76%	87%	91%	73%	82%	0.11	0.13	0.130	0.018	0.260	0.143	0.13	0.92
	BSM 3	Durham Bio (10% WTR2)	17	41	93%	97%	97%	96%	94%	0.07	0.08	0.008	0.007	0.031	0.041	0.08	1.89
	BSM 3D	Durham Bio (10% WTR2)	17	8	88%	96%	97%	94%	92%	0.17	0.19	0.012	0.007	0.054	0.070	0.17	2.49
	BSM 4	Tree Filter Mix w/10% WTR3	17	14	84%	96%	96%	95%	89%	0.23	0.25	0.008	0.008	0.050	0.093	0.23	2.43
	BSM 5	Control (No WTR)	17	7	-21%	-12%	-2%	-132%	-64%	0.71	-1.09	0.780	0.450	1.000	0.726	0.27	0.37
	BSM 6	BSM w/5% WTR3	17	9	71%	72%	78%	68%	73%	0.08	0.11	0.130	0.051	0.310	0.172	0.14	0.78
	BSM 7	BSM w/10% WTR3	17	13	85%	91%	93%	82%	88%	0.06	0.07	0.069	0.013	0.180	0.090	0.08	0.90
BSM 8	BSM w/15% WTR3	17	30	80%	92%	95%	80%	86%	0.11	0.13	0.079	0.010	0.200	0.121	0.12	1.01	

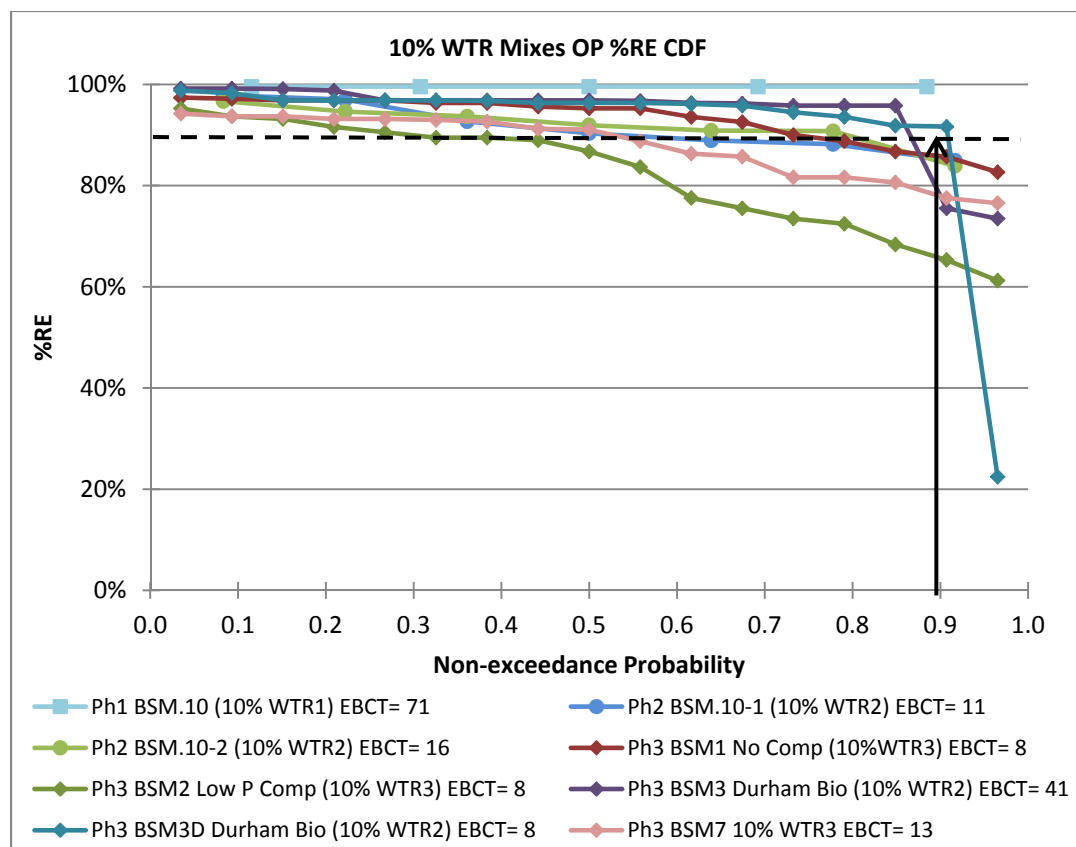
N=number of samples; EBCT = empty bed contact time; ER = efficiency ratio; Med %RE =median removal efficiency; 95% CI=nonparametric confidence interval about the median with actual confidence ranging from 94-98%; SD=standard deviation; CV=coefficient of variation (see Appendix for calculation methods). Shaded cells are BDL.

## Impact of WTR Processing on Column Performance

Results of this study suggest that processing WTR to dewater will increase performance of the filter media for phosphorus sorption. Greater solids content of WTR may be added to a mix without adding excess volume when WTR are processed. Dewatering may include use of drying beds, freeze-thaw drying beds, or mechanical separation by a belt filter press. BSMs containing WTR2 at 9% solids content, such as the Durham Bio mix (BSM3/3D), outperformed similar mixes containing WTR3 (5% solids), such as BSM7 from the phase 3 column study (Figure 27). The WTR volumetric application rate for these mixes is identical (10% of mix by volume), as are the other components in the mix. Median RE for BSM7 was 91%, as compared to that of BSM3 and 3D of 96-97%, in spite of the agedness and lower PSC of the WTR2 sample over the WTR3 sample ( $P_{\max} = 0.470$  mg P/g WTR2; 1.07 mg P/g WTR3). Though processed WTR may be more aged due to the time for processing, these results demonstrate that solids content is a more important factor than reduced sorption capacity associated with aging.

The cumulative distribution function in Figure 27 shows all of the mixes containing 10% WTR by volume from all 3 phases of column studies together. Even without the outlier in the BSM3 data removed, removals of the WTR2 mixes exceed those of the WTR3 mixes. Removal efficiencies of 90% are achieved by the duplicate phase 3 columns for 90% of the samples. Even BSM2, the Low P Compost mix, and in fact especially this one, did not live up to expectations by comparison. Only the mix containing no compost at all, BSM1 from phase 3, holds up by comparison with the WTR2 mixes. These findings seem to suggest that some processing to dewater WTR will improve their performance as an admixture, since only so much volume of raw WTR can be practically added to soil mixes. This is supported by the performance of BSM.10 from phase 1, with >99% removal for all samples, and the identical performance of other columns from the phase 1 column study. This mix contained WTR1, which had been frozen and thawed to promote water separation and decanting. Because the solids in WTR are generally composed of fine sediment, processed WTR with ~30-40% solids content are likely to increase OP removal due to the greater amount of sorption sites available as well as their effect in lowering infiltration rates, which in turn increases contact time.





**Figure 27. Column Performance for OP Removal from all columns with 10% WTR from phases 1-3.** Phase 1 mix (BSM.10) has box markers. Phase 2 mixes have circular markers. Phase 3 mixes have diamond markers. Empty Bed Contact Time is given for each mix in minutes.

A target orthophosphate concentration of <0.025 mg/L in surface waters was provided in 1986 EPA guidelines (USEPA Office of Water Regulations and Standards 1986). We set a target of <0.02 mg/L for the effluent of phase 3 columns. Some bioretention systems may see influent concentrations up to 0.2 mg P/L, as in the phase 3 short term loading, or even higher, particularly in the case of a nutrient spike. Figure 28 demonstrates that at least half of phase 3 effluent samples for the WTR2 mixes (BSM3/3D), the no compost mix (BSM1), and the tree filter mix (BSM4) were below a concentration of 0.02 mg P/L of orthophosphate (Figure 28), corresponding to a median removal efficiency of about 96%. Of the other mixes, those containing at least 10% WTR by volume met this criteria about 40% of the time. This figure shows clearly that below 10% WTR by volume, particularly at lower influent concentrations, P adsorption performance is compromised. The control mix, BSM5, for which effluent data is mostly above the influent line shows the degree to which that mix with no WTR leached P into the effluent. The top performing mixes in the phase 3 column studies may be ranked as BSM3 > BSM4 > BSM1 > BSM8 ~ BSM7. Looking back to Table 8 and Table 9, of the various PSC measures from Langmuir and Freundlich models, this ranking most closely resembles that of the Langmuir parameters measured from BSM isotherms: BSM8 > BSM7 > BSM3 > BSM1. Isotherm data all failed to predict the success of the tree filter mix, BSM4, relative to the other mixes. The tree filter mix was among the top performing mixes in all 3 phases of column studies, but isotherm models consistently predicted it to perform modestly to poorly compared to

the other BSMs. This consistent lack of power to predict relative performance of BSMs in columns implies that none of these provide a superb model for column behavior.

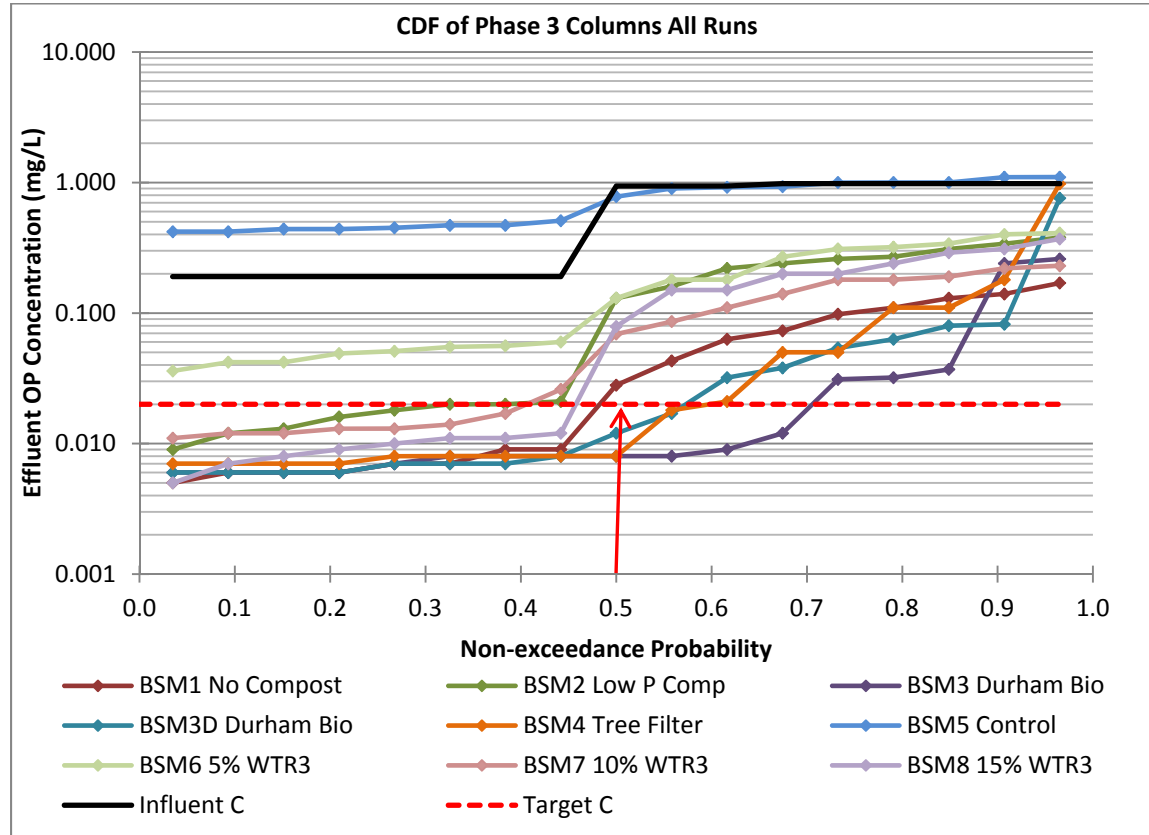


Figure 28. Cumulative Distribution of orthophosphate concentrations in phase 3 column study.

## Filter Media Lifecycle Analysis

Limitations of time and funds prevented running the phase 3 columns to breakthrough, but the data we have from the batch equilibrium studies coupled with the phase 3 column study may provide a prediction of expected filter media performance in the field for each BSM. The mass adsorbed ( $m_a$ ) in each column over the course of the 20 year nutrient load experiments in phase 3 was calculated as follows:

$$m_a = \sum [(C_{INF} - C_{EFF}) \times V_{EFF}]$$

Equation 24. Mass Adsorbed in Columns

where  $C_{INF}$ = influent OP concentration, mg/L;  $C_{EFF}$ = effluent OP concentration, mg/L; and  $V_{EFF}$ = volume of effluent collected over the interval from the last sample time to the current sample time for each effluent sample in each column. Since no evidence of breakthrough is seen in the data,  $m_a$  is presumably a fraction of the total mass each column has the capacity to sorb. We use the isotherm data to predict that total capacity:

$$m_p = M_{BSM} \times PSC$$

#### Equation 25. Predicted Mass Adsorption Capacity

where  $m_p$  = mass predicted that column has capacity to sorb (mg),  $M_{BSM}$  = dry mass of BSM in the column (mg), and PSC = phosphorus sorption capacity (mg P/g BSM), as defined by one of several parameters:  $P_{max}$  = Langmuir maximum sorption capacity, “measured  $q_{0.98}$ ” = equilibrium solid-phase concentration as predicted by the BSM Langmuir model at a starting concentration of 0.98 mg P/L, which is the median influent concentration during the phase 3 column study, or “calculated  $q_{0.98}$ ” = equilibrium solid-phase concentration as calculated by a weighted average of component Langmuir model predictions at a starting concentration of 0.98 mg P/L. The ratio of exhaustion indicates what fraction of the predicted mass was actually adsorbed during the column study, and years of capacity is determined by multiplying that fraction by the 20 years of nutrient load supplied to columns during the study. Predicted sorptive capacity is not applicable to BSM5, the control mix, because it proved to leach P overall in the column study.

The predicted mass adsorption for columns from isotherm data ( $m_p$ ) exceeds all observed values of mass adsorption ( $m_a$ ) from WTR-amended mix columns by more than an order of magnitude (Table 14). The range of actual mass adsorption in columns was 7-11 mg P, while the range predicted by the three different measures of PSC was 300-900 mg P. This data indicates that the columns could withstand more than 30 times the nutrient load they received over the duration of the column study before reaching breakthrough. The downward slope of removal efficiencies observed over time in the column data, however, calls into question the efficiency of filter media to continue removing phosphorus under such a load. If breakthrough were defined as below 50% removal, then several phase 3 mixes appear to be very near breakthrough after just 20 annual OP loads (Figure 26) and the 5% WTR mixes from phase 2 reach that benchmark at around 40-45 annual OP loads (Figure 25).

The predicted filter life from each of the three methods shown in Table 14 far exceeds any reasonable lifespan of a built bioretention system. These systems are typically expected to last no more than around 10-20 years, one reason being that clogging of filter media by sediments tends to slow the infiltration rate to the point of ineffectiveness within that time span (Pitt and Clark 2010). The Langmuir  $P_{max}$  parameter as measured from the BSM isotherms predicts filter bed lives of well over 1000 years for all WTR-amended mixes. The Langmuir model predicted equilibrium solid-phase concentration of such beds, as predicted by BSM isotherms (measured  $q_{0.98}$ ) and by component isotherms as a weighted average (calculated  $q_{0.98}$ ), predict a lesser bed life, but still one that is much higher than column data seems to indicate.

**Table 14. Capacity of soil mixes based on Langmuir modeled mass adsorption capacity of columns ( $m_p$ ) and actual mass adsorption( $m_a$ ) during column study phase 3.**

<b>BSM</b>	<b>Description</b>	<b><math>m_a</math> (mg P)</b>	<b>Meas <math>P_{max}</math></b>	<b><math>m_{p1}</math> (mg P)</b>	<b>Ratio of exhaust -ion</b>	<b>Filter Life (years)</b>	<b>Meas <math>q_{0.98}</math></b>	<b><math>m_{p2}</math> (mg P)</b>	<b>Ratio of exhaust -ion</b>	<b>Filter Life (years)</b>	<b>Calc <math>q_{0.98}</math></b>	<b><math>m_{p3}</math> (mg P)</b>	<b>Ratio of exhaust -ion</b>	<b>Filter Life (years)</b>
<b>BSM1</b>	<b>BSM w/No Compost</b>	10.06	0.891	738	0.014	1467	0.661	547	0.018	1088	0.457	378	0.027	752
<b>BSM2</b>	<b>BSM w/Low P Compost</b>	8.35	1.009	844	0.010	2020	0.623	521	0.016	1248	0.407	341	0.025	816
<b>BSM3</b>	<b>Durham Bio (10% WTR2)</b>	10.31	1.032	830	0.012	1610	0.710	571	0.018	1108	0.384	309	0.033	599
<b>BSM3D</b>	<b>Durham Bio (10% WTR2)</b>	9.77	1.032	830	0.012	1698	0.710	571	0.017	1169	0.384	309	0.032	632
<b>BSM4</b>	<b>Tree Filter Mix</b>	9.32	0.506	544	0.017	1167	0.370	398	0.023	853	0.421	452	0.021	970
<b>BSM5</b>	<b>Control Mix</b>	-1.41	N/A	0	N/A	N/A	NA	0	N/A	N/A	0.350	275	N/A	N/A
<b>BSM6</b>	<b>BSM w/5% WTR3</b>	7.89	0.792	607	0.013	1537	0.404	310	0.025	784	0.382	292	0.027	741
<b>BSM7</b>	<b>BSM w/10% WTR3</b>	9.39	1.242	1020	0.009	2174	0.783	643	0.015	1370	0.377	310	0.030	660
<b>BSM8</b>	<b>BSM w/15% WTR3</b>	8.75	1.161	978	0.009	2235	0.954	804	0.011	1836	0.388	327	0.027	747

The calculated  $q_{0.98}$  values are below the measured values, likely due in part to missing wood chips data, for which isotherm experiments were not undertaken. An attempt to deduce a sorption capacity for wood chips using the available component and isotherm data did not prove fruitful. Wood chips and compost2 were the only components for which isotherm data is not available. Literature suggests that wood chips has some P sorption capacity, while the performance of BSM2, in which compost1 was replaced with compost2, seems to suggest that compost2 leaches P, as does compost1. In the absence of data, however, these components were given a PSC value of 0. Further investigation into the use of component analysis for determining PSC of mixes may provide greater insight into the roles of each component of filter media with respect to P adsorption and the interactions of components with one another when they are mixed together. For instance, the role of sand remains a mystery, as the Langmuir linear regression seems to indicate that it achieves almost no adsorption and yields a negative  $P_{max}$  value; yet, the Langmuir model predicted  $q$  at high influent concentrations ( $>0.2$  mg/L) claims sand as the leading sorptive material for the phase 3 column study mixes (Table 15). The percent contributions to PSC of the soil mixes presented in Table 15 are calculated by dividing the component  $q_{0.98}$  by the total calculated  $q_{0.98}$  from Table 14.

**Table 15. Contributions of each component to the PSC of bioretention soil mixes.**

BSM	BSM Description	Sand	Wood Chips	Loam	Compost	WTR
BSM 1	No Compost BSM	79.3%	*	19.7%	none	1.0%
BSM 2	Low P Compost BSM	87.98%	*	10.95%	*	1.07%
BSM 3	Durham Bio (BSM w/10% WTR2)	97.0%	*	12.1%	-10.0%	0.9%
BSM 4	Tree Filter Mix w/ 10% WTR3	106.0%	none	none	-6.8%	0.8%
BSM 5	Control (No WTR)	108.9%	*	13.6%	-22.5%	none
BSM 6	BSM w/5% WTR3	102.5%	*	12.8%	-15.9%	0.6%
BSM 7	BSM w/10% WTR3	96.8%	*	12.0%	-10.0%	1.2%
BSM 8	BSM w/15% WTR3	91.6%	*	11.4%	-4.7%	1.7%

\* denotes missing data; “none” indicates a component not present in a given mix.

Loam appears to also significantly contribute to mix sorption capacity, while WTR represents only about 1% of the mix sorption capacity. This is inconsistent with the findings in phase 3 column studies that all mixes containing WTR removed  $>50\%$  of OP, while the mix containing no WTR leached OP. As discussed earlier, loam and especially sand have a much higher % dry mass portion in the mix than the raw WTR at 5-10% solids, which outweigh the higher PSC of WTR as compared to the other components. Langmuir modeled  $q$  values were also particularly variable for both sand and loam with differences in influent concentrations (Table 6).

Column studies and batch equilibrium isotherm studies support the effectiveness of WTR as an admixture to bioretention soil mixes to remove orthophosphate from runoff. However, as exemplified by the confounding results in Table 15, further work is needed to understand the roles of soil mix components and the efficiency of the filter bed in order to predict filter bed life and appropriate filter bed sizing.

## Summary of Laboratory Results

WTR-amended bioretention soil mixes effectively removed OP from nutrient spiked runoff in batch sorption equilibrium studies and column studies, whereas a control mix containing no WTR demonstrated little to negative removal (i.e., leaching) of OP in all experiments. Of the four samples of WTR tested from the Durham treatment plant, the median  $P_{\max}$  was 1.0 mg P/g WTR; a median of  $P_{\max}$  values reported from literature was 7.4 mg/g (Table 10). Although PSC measures of Durham WTR were on the low end compared to others reported in literature, removal efficiencies in column studies exceeded 50% for nearly all samples of all WTR-amended BSMs in columns. Several BSM columns achieved 99% removal, while the unamended mix (BSM5) leached OP into the effluent during most events. BSMs containing at least 10% WTR by volume (at solids contents between 5-33%) consistently maintained high OP removal efficiencies in column studies, with median RE ranging from 86% to 99% (Figure 27).

Raw WTR with solids content <10% caused logistical issues for mixing the components of the BSM, including clumping of the mix and loss of WTR as it runs off as liquid. Even at 5-10% solids, which is relatively high for raw WTR, the mixing of BSMs at 15% by volume of WTR proved sloppy. The solids content of raw WTR samples may be as low as <1%, but these very high water content WTR are simply impractical for applications to BSMs. While raw WTR are likely to be fresher and therefore more reactive (McLaughlin et al. 1981), it appears some processing is necessary to dewater WTR to a point that it is practical to mix it with other BSM constituents and to obtain higher dry mass content in a BSM.

BSMs containing WTR2 at 10% solids content, such as the Durham Bio mix (BSM3/3D), outperformed similar mixes containing the 5% solids WTR3, such as BSM7 from the phase 3 column study (Figure 27). The WTR volume application rate for these mixes is identical (10% of mix by volume), as are the other components in the mix. Median RE for BSM7 was 91%, as compared to that of BSM3 and 3D of 96-97%, in spite of the agedness and lower PSC of the WTR2 sample over the WTR3 sample ( $P_{\max} = 0.470$  mg P/g WTR2; 1.07 mg P/g WTR3). Though aging of WTR has been implicated in reducing its sorption capacity (McLaughlin et al. 1981), these results suggest that solids content is a more important factor in the effectiveness of a WTR admixture.

A freeze-thaw method effectively increased the solids content of WTR1 and WTR4 samples to about 33% and 41%, respectively. Phase 1 column study BSMs all contained WTR1 as an admixture and were the top column performers of all three column study phases with approximately 99% RE for all WTR1-amended mixes. The freeze-thaw method is therefore highly effective and has been shown to have no negative effects on sorption capacity of aluminum oxides (McLaughlin et al. 1981). The Langmuir  $P_{\max}$  values for WTR1 and WTR4, both processed by freeze/thaw methods, were among the highest for materials tested in this study at 3.37 mg P/ g WTR1 and 1.02 mg P/ g WTR4 (Table 6).

Soil tests and isotherm models provide some insight into the phosphorus sorption capacities of materials and mixtures. However, isotherm models for this study were not able to accurately predict column or field performance by either mix or component analysis. Column studies indicated that the high sand content tree filter mix (BSM4 in phase 3 column study) was a top performer, while all isotherm analyses predicted it to have a moderate PSC at best (Table 8).

One contributing factor may be that component isotherm analyses of BSMs were incomplete due to the lack of isotherm data for wood chips and compost<sup>2</sup>. Isotherm models appeared to overestimate the PSC of all mixes, suggesting that they have hundreds of years of capacity for OP removal (Table 14). Column studies indicated a decline in removal efficiencies earlier than predicted by isotherm models. Future work may illuminate the connection between isotherm models and performance of column and field studies.

The adsorption process is based on the presence of solid aluminum (hydr)oxides to which soluble phosphorus may adsorb, which explains why the dry mass of WTR amendments is so important for performance of WTR-amended BSMs. Thus, O'Neill and Davis (2012), among other researchers, make recommendations for WTR amendments based on % dry mass of overall soil mix. They also assume the use of processed and dewatered WTR. O'Neill and Davis (2012) recommended a 5% WTR admixture by mass for their specific WTR to achieve an oxalate ratio of at least 20 to 40 in the BSM. The estimated oxalate ratio (from Mehlich 3 extractions) for the Durham bioretention mix was just below the O'Neill and Davis standards at 17.3 (Table 4). All WTR-amended BSMs in the present study contained a WTR mass content <1% (Figure 15), due to the low solids content (5-10% solids) of raw WTR vs. processed WTR, as used in the O'Neill and Davis (2012) study.

## **Field Bioretention Monitoring Results**

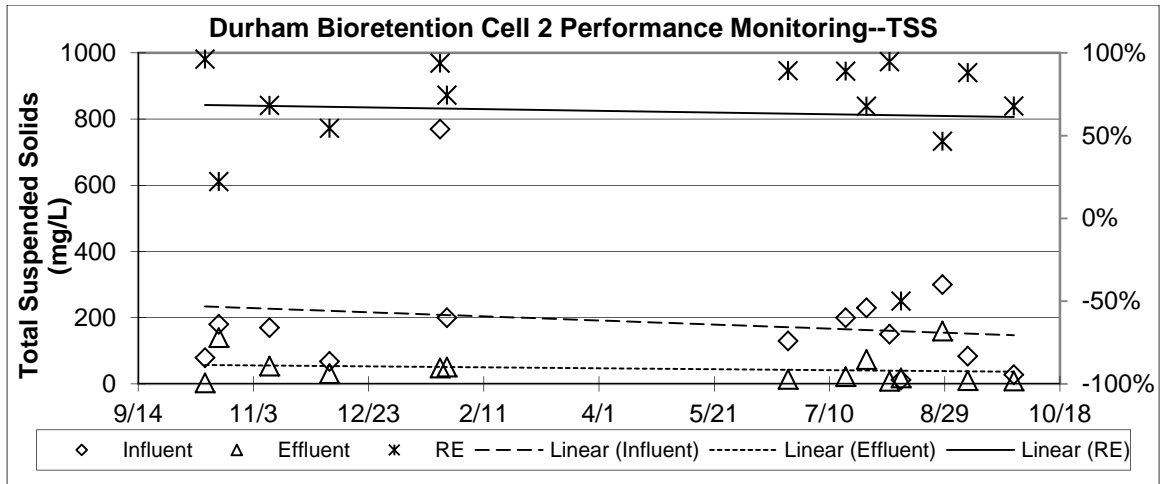
Construction and planting of the Bio-5 Durham bioretention system was completed late in the growing season, August 2011 (Figure 29); it was filled with 2 feet filter media identical to BSM3/3D in the phase 3 column study (Figure 12 and Figure 13). UNHSC typically prefers to allow three months for establishment between planting and the beginning of monitoring. Due to the approach of winter, the first storms were monitored for Cell 2 in October 2011, only two months after the completion of the Bio-5. Along with an early snowstorm at Halloween in 2011, the late planting of the system contributed to significant plant death over the 2011-2012 winter (see Appendix D for construction schedule). New plants were added to the systems in May of 2012. Although the systems were seeded with water from the UNHSC gravel wetland system to inoculate the community of denitrifying bacteria soon after construction, plant deaths and lack of system ripening likely negatively impacted system performance.



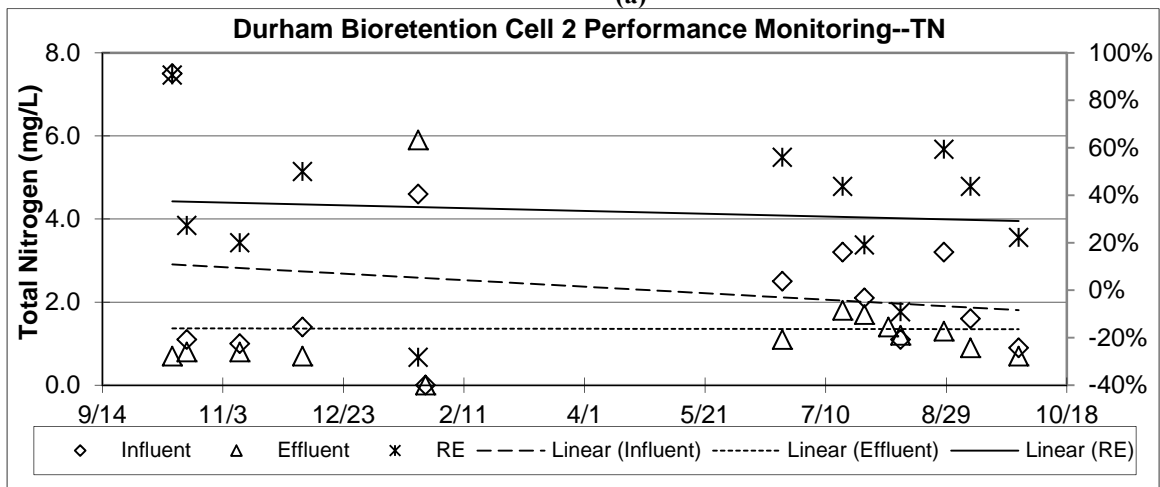
(a) (b)  
**Figure 29. Bio-5 in Durham, NH immediately after completion (a) and during the first storm (b), Cell 2 in the foreground in each. Photos by Viktor Hlas.**

The monitoring for Cell 1 proved challenging to set up, so data from several storms was invalidated, leading to a smaller dataset of only 4 storms for Cell 1, all collected from February to May of 2012. All of these monitored events for Cell 1 occurred in winter/spring 2011 just before the systems were replanted. For these reasons, the Cell 1 dataset is not considered usable (see Appendix E for time series data). Cell 2 was monitored soon after construction in 2011, and for several more storms in summer 2012, after the replanting (Figure 30). The nitrogen data from the early Cell 2 storms was later disqualified due to the lack of plant establishment, leading to smaller datasets for nitrate and TN from Cell 2. Cell 2 nutrient removal rates, as indicated by the solid trendlines in Figure 30, remain mostly constant from fall 2011 through fall 2012. A couple of very low influent TP storms in 2012 are associated with 0% or negative removal, which appears to pull the RE trendline into a downward slope (Figure 30d). The effluent concentration trendline is very nearly horizontal for TP, as well as for the other contaminants, indicating fairly consistent performance for these systems.

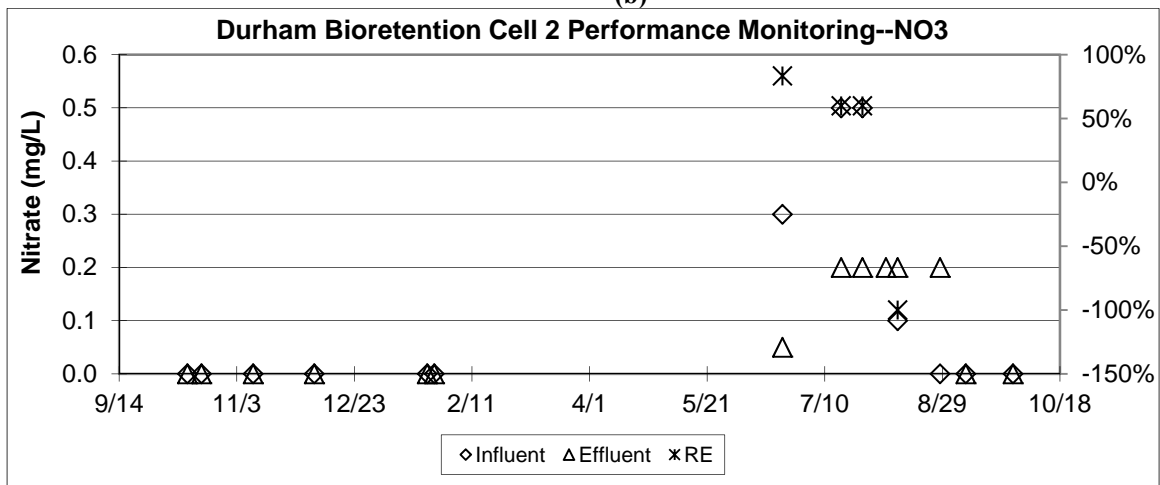




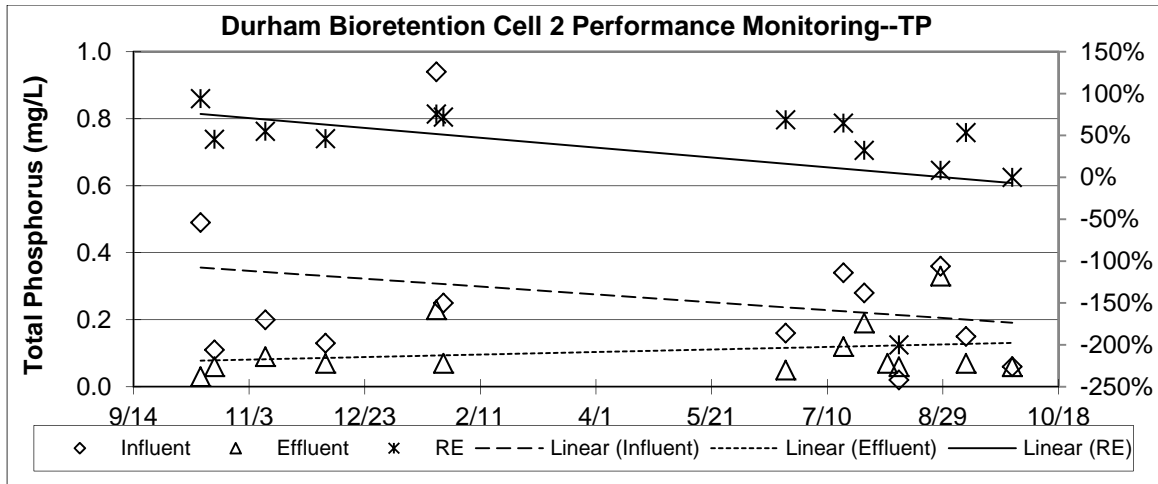
(a)



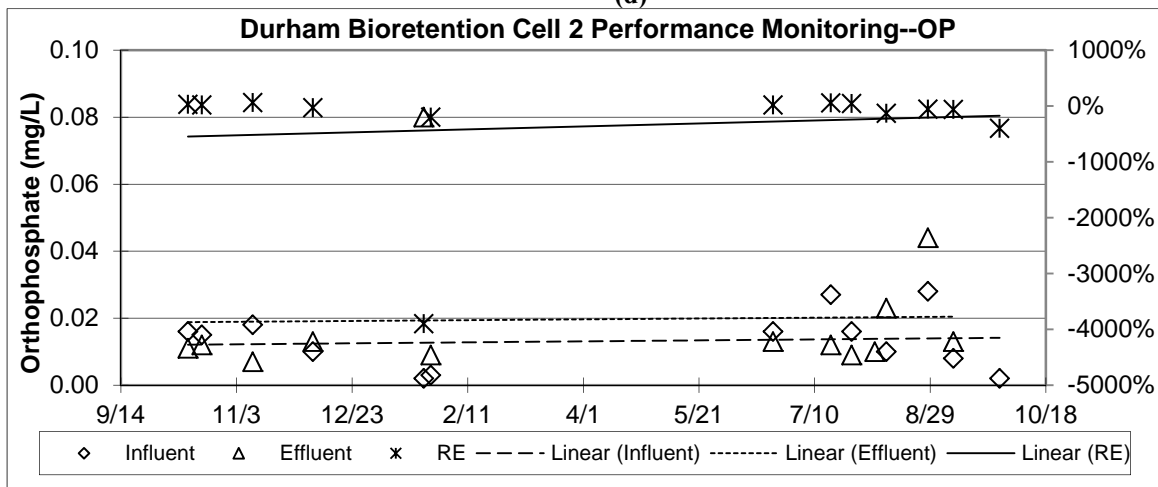
(b)



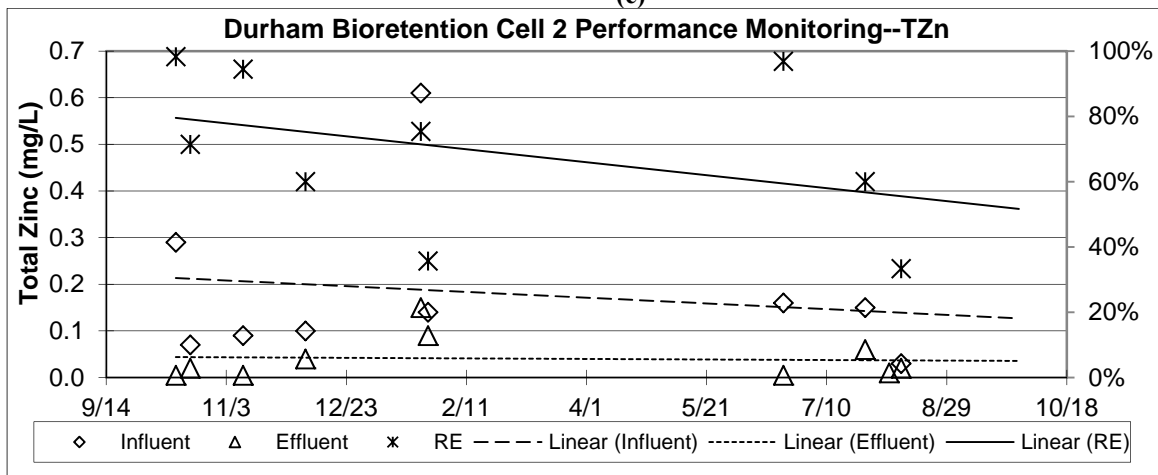
(c)



(d)



(e)



(f)

Figure 30. Time Series Water Quality Data from Bio-5 Cell 2 for contaminants (a) Total Suspended Sediments, (b) Total Nitrogen, (c) Nitrate, (d) Total Phosphorus, (e) Orthophosphate, and (f) Total Zinc.

The column study data indicates that mixes containing WTR may be expected to remove phosphorus from runoff at a much higher efficiency than those mixes not including WTR, e.g.

BSM5, the control mix in column study phase 3. The control mix from the column study may be compared to mixes installed in Bio-3 (60% sand, 20% wood chips, 10% soil, 10% compost) and Bio-4 (70% sand, 30% compost) and monitored by UNHSC from 2009-2010. Columns identified as BSM3 and BSM3D contained an identical mix to that installed in Bio-5 (Cells 1 and 2) in Durham, NH and monitored from 2011-2012. Another UNHSC vegetated system, the gravel wetland system (Figure 2), is also used as a comparison, primarily because it is the model for the ISR design in Bio-5 and the gold standard for nitrogen removal from runoff (UNH Stormwater Center et al. 2012).

Bio-3 and Bio-4 each include 2 feet of their respective filter media mixes, as in Bio-5, but do not include an internal storage reservoir (Figure 1). The subsurface gravel wetland contains only 8 inches of wetland soil to support the wetland plants above the gravel storage reservoir after which the bottom portion of Bio-5 is modeled. All of these systems are among those included in Low Impact Development (LID) filtration designs. These are systems vegetated with native plants, requiring minimal maintenance and providing hydrologic and water quality benefits to developed sites.

Each of the UNHSC systems was monitored for several contaminants, including two different measures of sediments: total suspended solids (TSS) and suspended sediment concentration (SSC), as well as total nitrogen, nitrate, total phosphorus, orthophosphate, and total zinc. Hydraulic impacts of these systems were also evaluated, and though these are not the focus of this project, it is worth noting that these systems all have the ability to significantly reduce peak flows (Roseen et al. 2010). Box-and-whisker plots summarize the complete influent concentration dataset along with effluent concentrations from each of these systems (Figure 32).

### **Internal Storage Reservoir Performance for Nitrogen Removal**

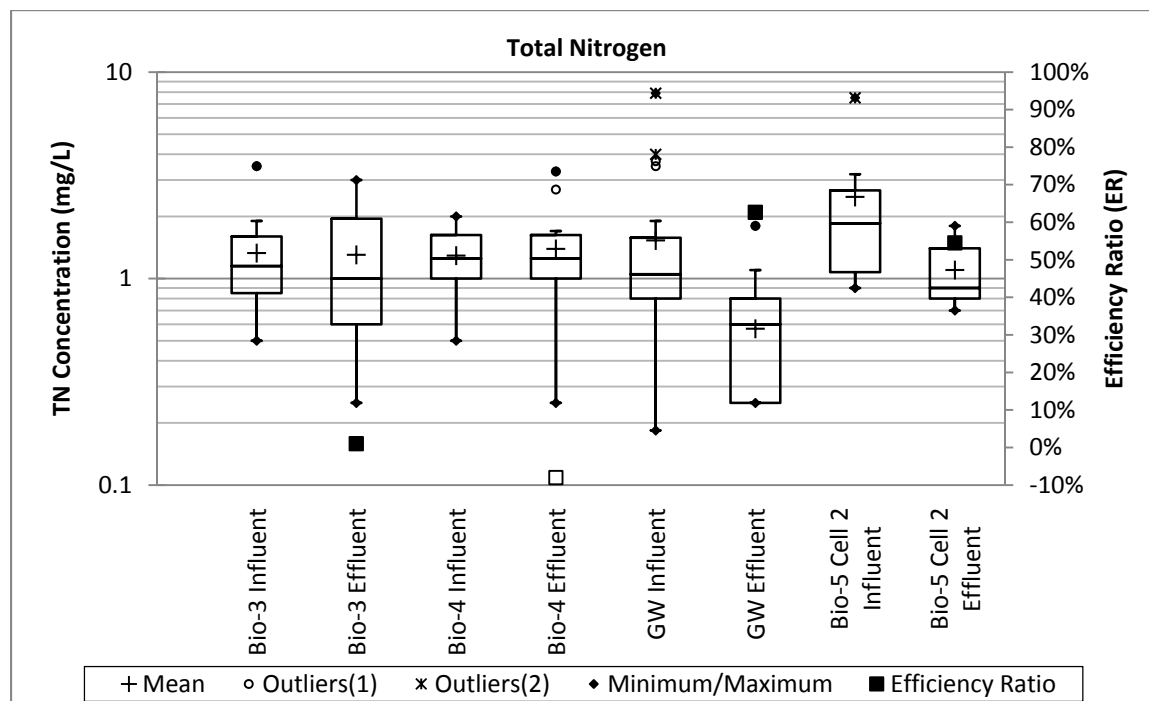
The modified structural design of the Bio-5 system to mimic the anaerobic conditions of the gravel wetland proved at least moderately effective in the Bio-5 system. The small dataset from the system after only one growing season limits the conclusions that may be drawn from this monitoring period. Site conditions and modifications likely reduced the performance of Cell 2 to below its potential. The sloped surface of the systems allowed less ponding than designed, and caused many storms to bypass. Repairs to the parking lot changed the drainage area during the monitoring period. Despite these conditions, the Bio-5 Cell 2 removed total nitrogen and nitrate with efficiency ratios of 54% and 67%, respectively (Figure 32). Dissolved oxygen levels in the catchbasin for Bio-5 Cell 2 were monitored for four summer 2012 storms Table 16. The median DO concentration of 0.5 mg/L indicates that the internal storage reservoir is functioning as intended. The gravel wetland system, which is known to have an anaerobic zone that removes nitrogen, had a measured DO concentration of 0.64 mg/L in September 2011.

The denitrification process only occurs when no oxygen is available to be a terminal electron acceptor. Since the actual DO concentrations within the internal storage reservoir cannot be measured, we assume that the very low DO concentrations in the catchbasin into which the effluent from the system flows indicate that the ISR has become anaerobic. The reduced nitrogen concentrations in the effluent from Bio-5 Cell 2 validate this assumption. Although effluent TN and nitrate concentrations from Bio-5 Cell 2 are not necessarily improved from the

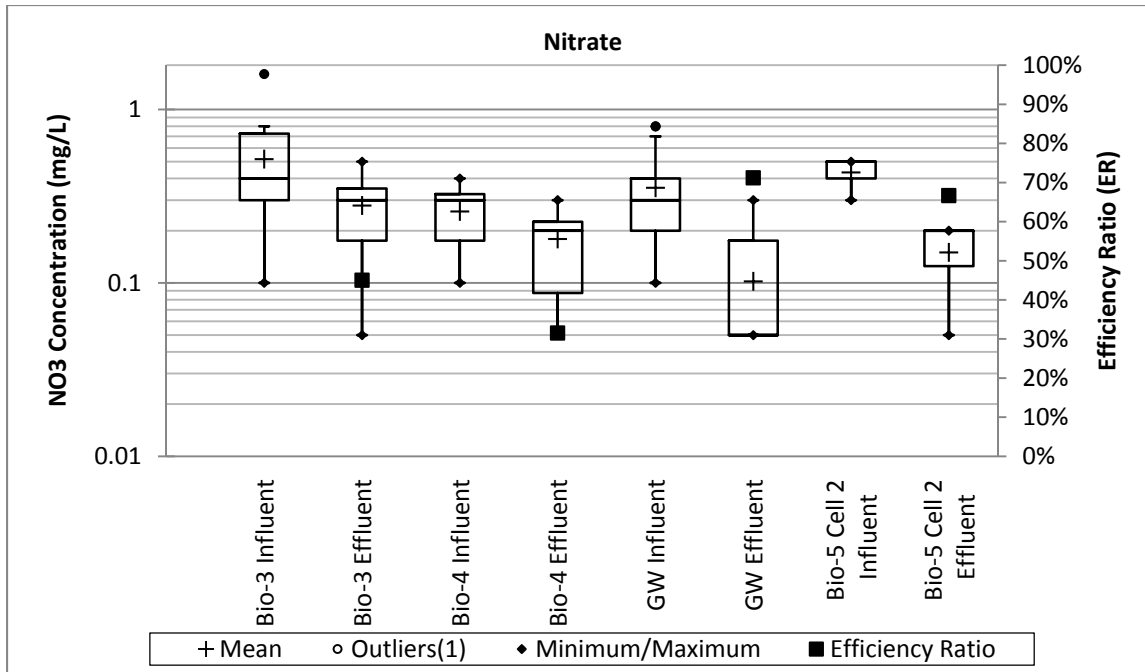
other systems, efficiency ratios in Cell 2 show distinct improvement over Bio-3 and Bio-4 while approaching those of the gravel wetland. Influent concentrations were generally higher at the Bio-5 site than at the other sites, which effects performance in some cases.

**Table 16. Summary Statistics of Dissolved Oxygen concentrations in Bio-5 Cell 2 catchbasin for four summer 2012 storms.**

DO Concentrations in Bio-5 Cell 2 Catchbasin:					
Median C =	0.5 mg/L	Mean C =	1.05 mg/L	N =	2070
95% CI about the Median:	0.5 mg/L	95% CI about the Mean:	1.01 mg/L	SD =	1.07
	0.5 mg/L		1.10 mg/L	CV =	1.01



(a)



(b)

**Figure 31. Box-and-Whisker Plots for 4 UNHSC vegetated systems' performance for (a) Total Nitrogen and (b) Nitrate.**

*Solid squares indicate efficiency ratios (ER); open squares indicate negative ER.*

## Performance of Systems for Phosphorus, TSS, and Zinc

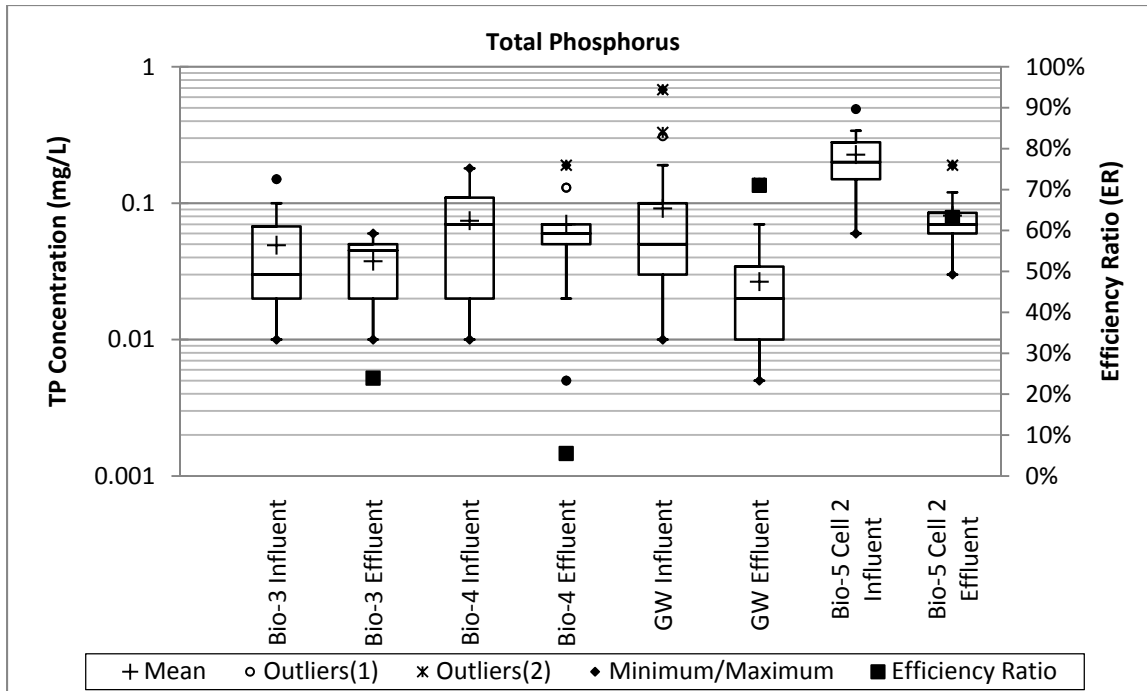
Effluent water quality generally improved over influent as the result of treatment by Bio-5 Cell 2 (Figure 32). Although effluent concentrations of TP, OP, TSS, and Zn are sometimes higher compared to those from other systems, they are consistently reduced from the influent coming into Bio-5 Cell 2, which is frequently higher than measured at other sites. Removal efficiencies and efficiency ratios are methods of normalizing the treatment provided by the systems by their various influent concentrations.

The design mix installed in Bio-5 in Durham, NH contained a 10% WTR by volume amendment and achieved median RE of 20% for OP and 55% for TP (Figure 33) and efficiency ratios of 23% for OP and 63% for TP (Figure 32). The same mix in phase 3 column studies achieved a median removal of 96-97%. The difference is suspected to be in part because of short-circuiting in Bio-5, due to placement of curb cuts very near the overflow drain of the system. Another likely cause of decreased performance in the field as compared to column studies is incomplete mixing of filter media. Use of a backhoe to mix filter media is a common practice but may be insufficient, particularly when WTR is added to the mix. Particularly raw WTR, has a tendency to clump, which could lead to nonuniform distribution in the filter media and less contact of influent with the adsorbent material. This is another reason that processed WTR may be preferable to raw WTR, in addition to excellent performance of processed WTR as an admixture in phase 1 column study mixes (> 99% median removal efficiency).

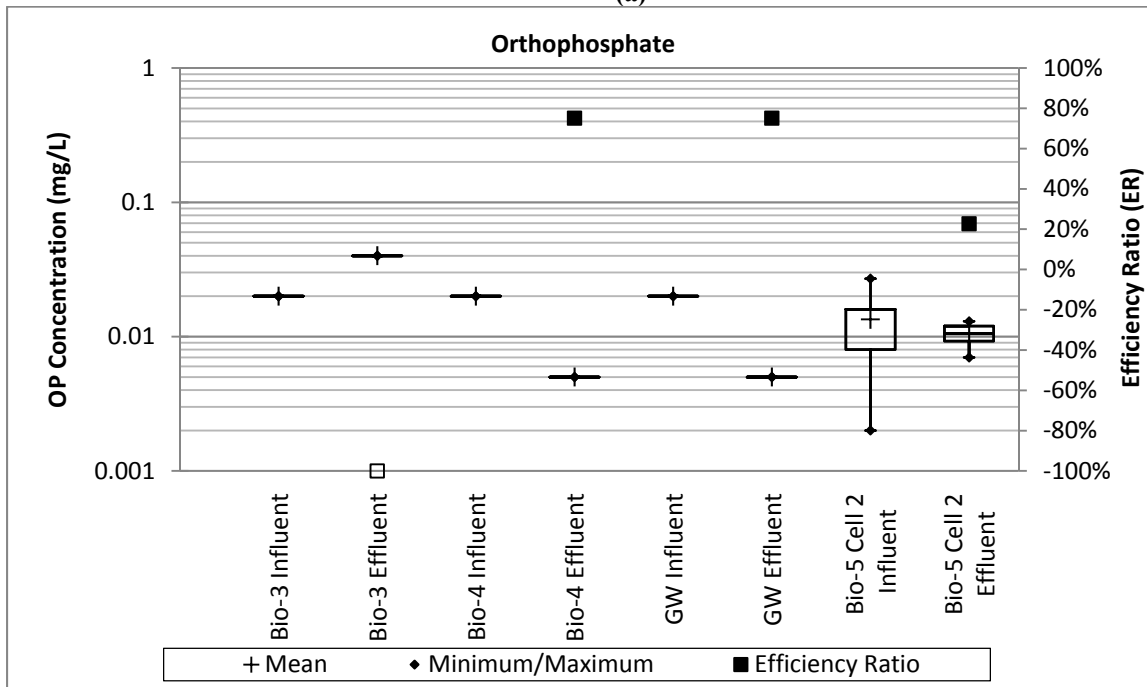
Some summary statistics for pH are provided in Table 17, since very acidic conditions may cause phosphorus and/or aluminum to become unstable ( $\text{pH} < 5$ ) (Gallimore et al. 1999). Median and mean pH in the catchbasin for 8 storms show the system to be just slightly acidic (6.6-6.7). Even the minimum recorded pH of 6.0 is only slightly acidic and does not run the risk of causing phosphorus or aluminum to leach from the system. The system does become rather basic during some of the winter storms.

**Table 17. Summary Statistics of pH in Bio-5 Cell 2 catchbasin for four winter and four summer storms.**

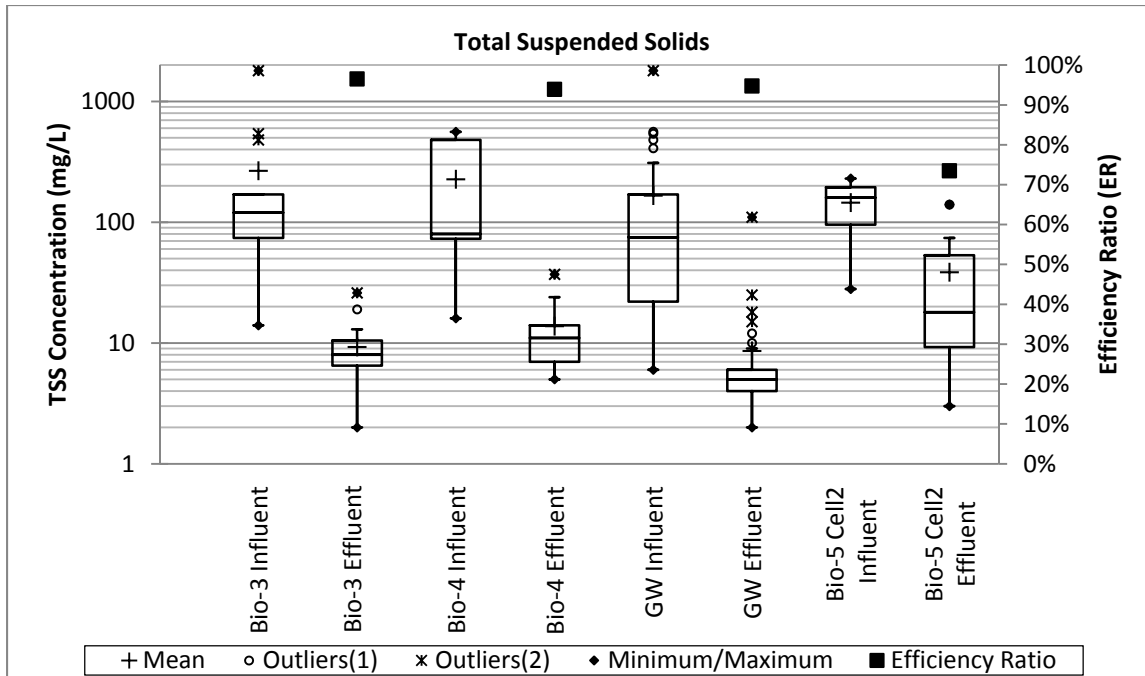
<b>pH in Bio-5 Cell 2 Catchbasin:</b>					
Median C =	6.6	Mean C =	6.72	N =	5559
Min pH =	6.0	95% CI about the	6.71	SD =	0.28
Max pH =	8.6	Mean:	6.73	CV =	0.04



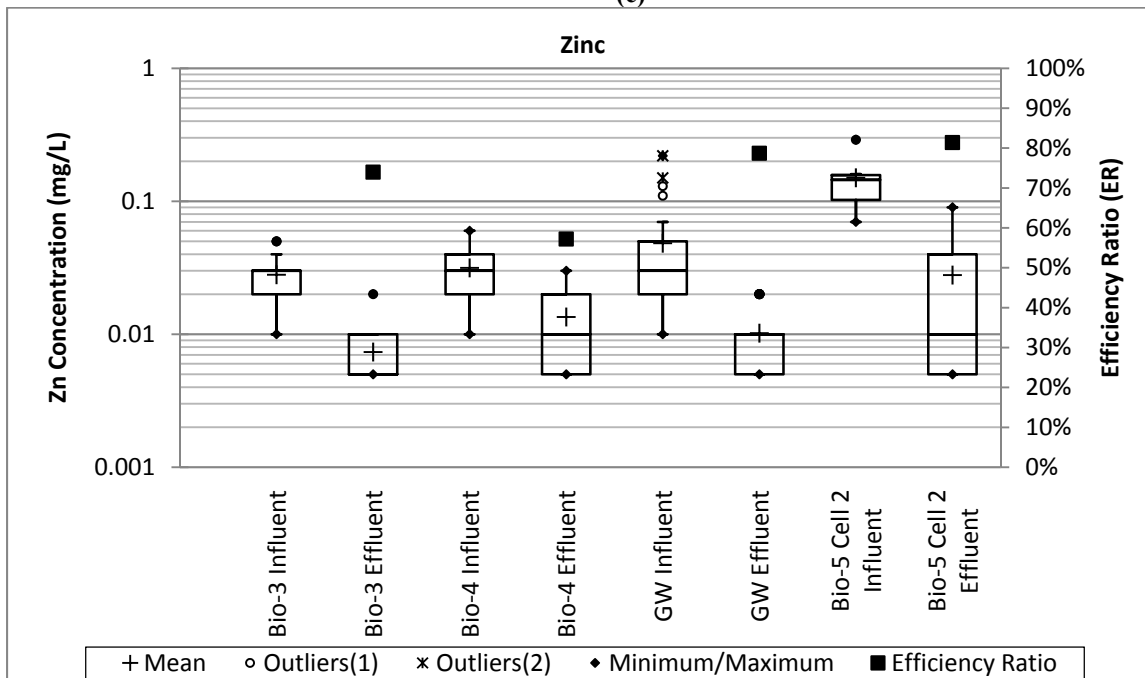
(a)



(b)



(c)



(d)

Figure 32. Box-and-Whisker Plots for 4 UNHSC vegetated systems' performance for (a) Total Phosphorus, (b) Orthophosphate, (c) Total Suspended Solids, and (d) Total Zinc. Solid squares indicate efficiency ratios (ER).

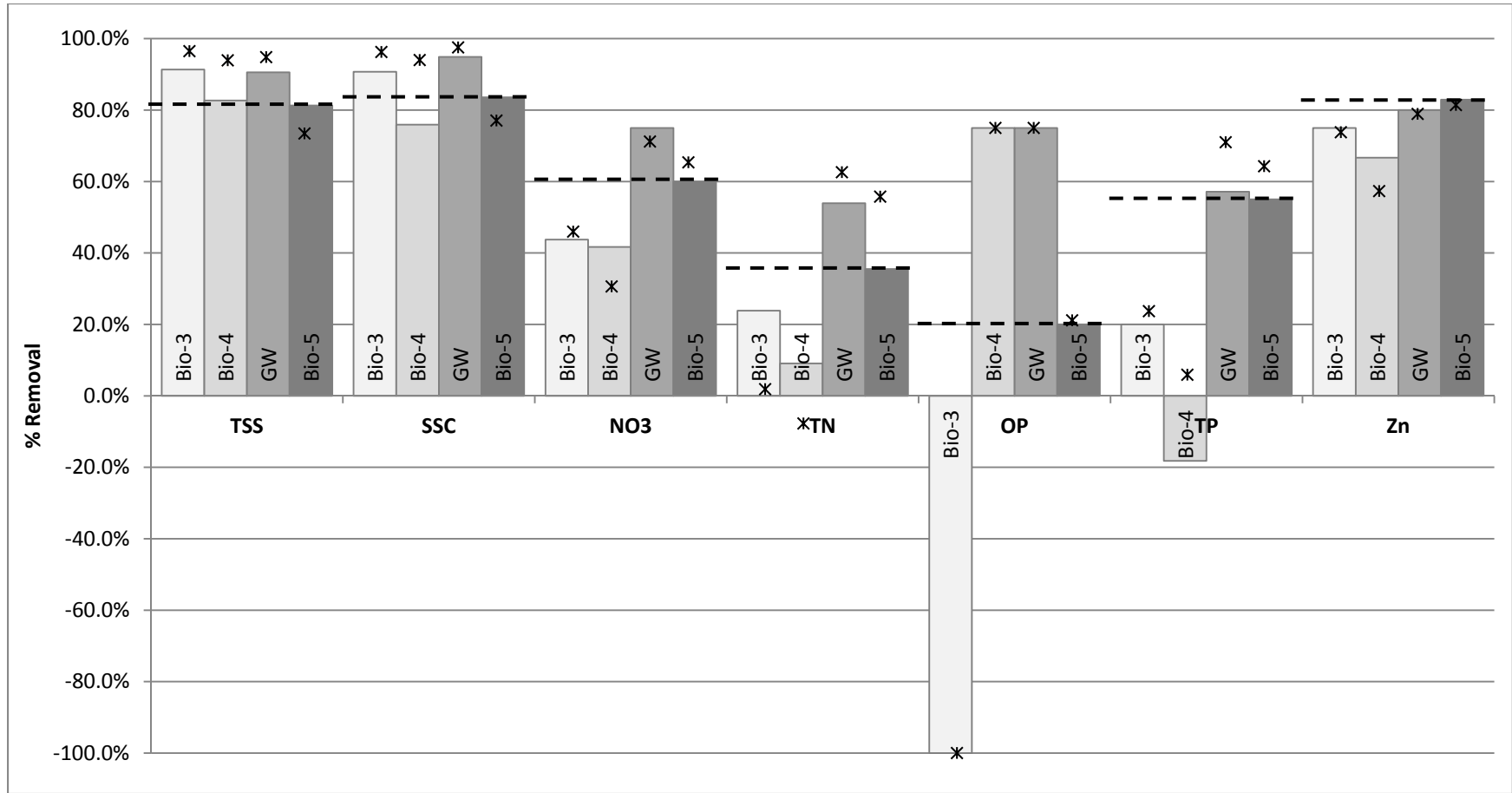
### Impact of Influent Concentration on Performance

A summary of how Bio-5 compares to the other systems in terms of contaminant removal is presented in Figure 33 with the efficiency ratios and median removal efficiencies of the four



systems for the primary contaminants of interest. An alternative sediment measure (suspended sediment concentration, SSC) is also provided as a comparison to TSS.

In general, Bio-5 Cell 2 removes about as well or better than other systems (Figure 33). The dashed black line across the figures indicates the median removal efficiency for Cell 2. Cell 2 matches or surpasses the median removals of Bio-3 and Bio-4 for all contaminants except sediments, for which Bio-3 achieves 90% removals to Cell 2's 81-85% removal and orthophosphate. Though Cell 2 did not attain equivalent nitrogen removals to the gravel wetland system in this monitoring period, it did approach them, exceeding NO<sub>3</sub> and TN median removal efficiency of both bioretention systems with 60% and 36%, respectively (compare to 44% and 24% respectively in Bio-3). The changes to the drainage area during the monitoring period appear to have increased the hydraulic load that Cell 2 handles beyond the intent of the design. Median removal efficiencies generally tell the same story as the efficiency ratios of the systems.



**Figure 33. Contaminant Removals by 4 UNHSC vegetated stormwater treatment systems.**  
 Columns indicate the median %RE, while \*'s represent efficiency ratios.

A further examination of influent concentrations of contaminants from the different systems reveals that Bio-5 influent concentrations were frequently higher than in the other systems. The median influent TP concentration in Bio-5 Cell 2 was 0.2 mg/L as compared with 0.05 mg/L median influent concentration for the other systems combined (Figure 34).

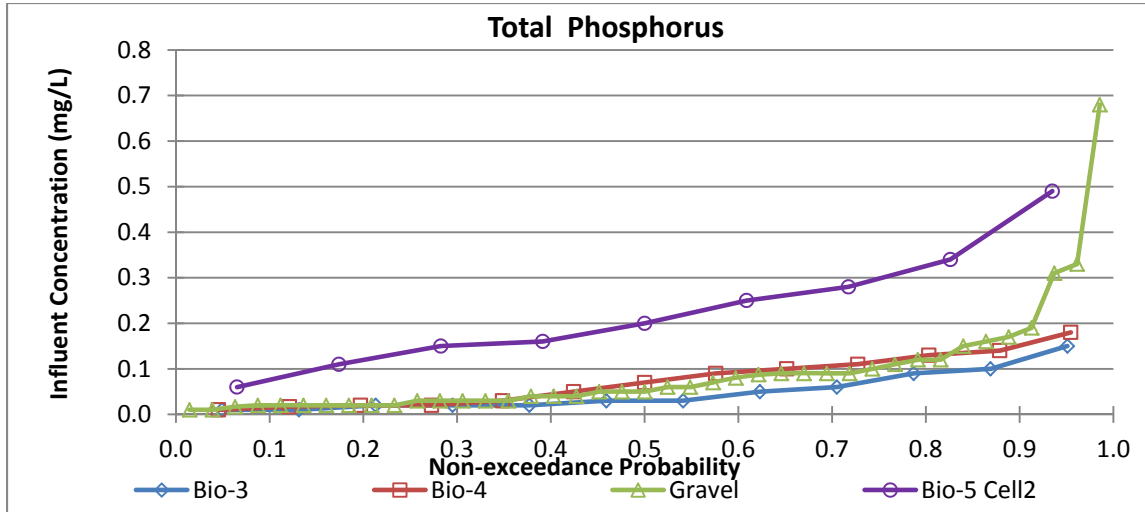
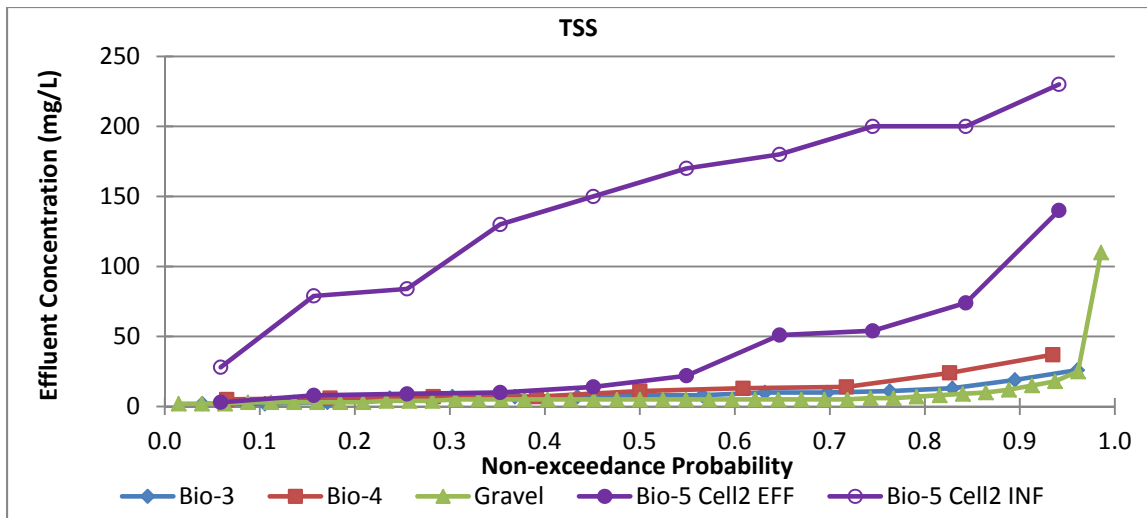


Figure 34. Influent Concentration distribution for 4 vegetated systems monitored by UNHSC.

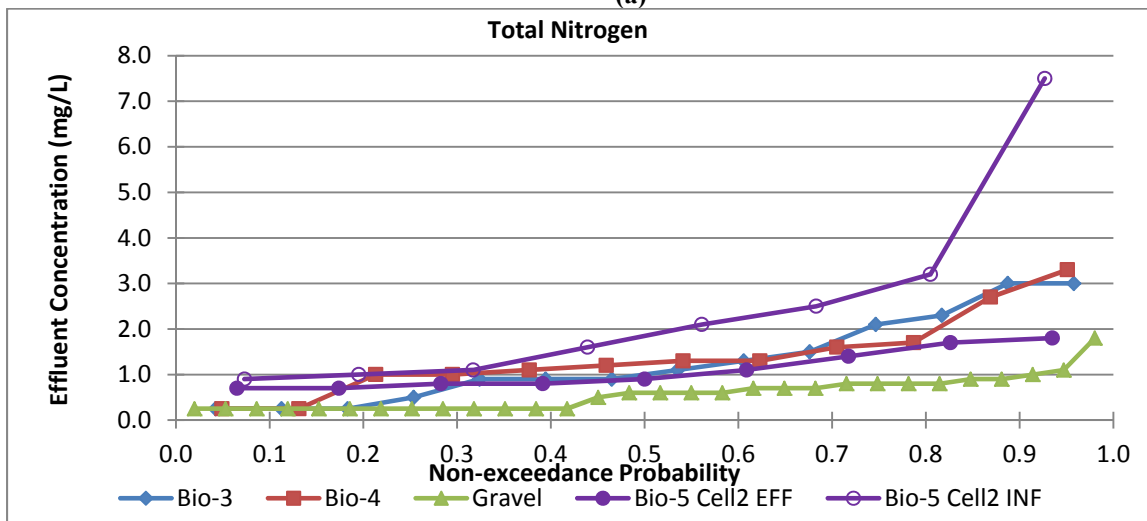
As seen in the previous figures, removals were generally very good for Cell 2, and effluent concentrations were generally low and on par with those from other systems, with the exception of some high sediment effluent samples. Although effluent phosphorus concentrations from Cell 2 do not appear as an improvement over Bio-3 and Bio-4 from these figures, the influent concentrations and removal efficiencies presented above must also be taken into consideration. All orthophosphate concentrations were below the 0.02 mg/L standard, and in fact consistently hovered around half of that (Figure 35e).

The impact of influent concentration on system performance can be seen by plotting the influent and effluent concentrations together on a cumulative distribution function. Figure 35 does that by presenting CDFs of effluent concentrations from each of the vegetated systems, along with the influent concentration from Bio-5 Cell 2. For TSS, Zn, TP, and NO<sub>3</sub>, the influent and effluent lines trend upwards somewhat together. This indicates that higher influent concentrations influence the performance of the system such that higher effluent concentrations occur. Influent concentration appears to have very little effect on the effluent concentration of OP from Cell 2, however. Effluent concentrations remain consistently around 0.01 mg P/L, even when influent concentrations are lower, ranging from 0.07 to 0.93 mg P/L (Figure 35e). The available P in the bioretention soil mix due to the compost component may contribute to this behavior. The leaching properties of the compost and adsorptive properties of WTR and other components seem to counteract each other to maintain a mostly steady effluent OP concentration.

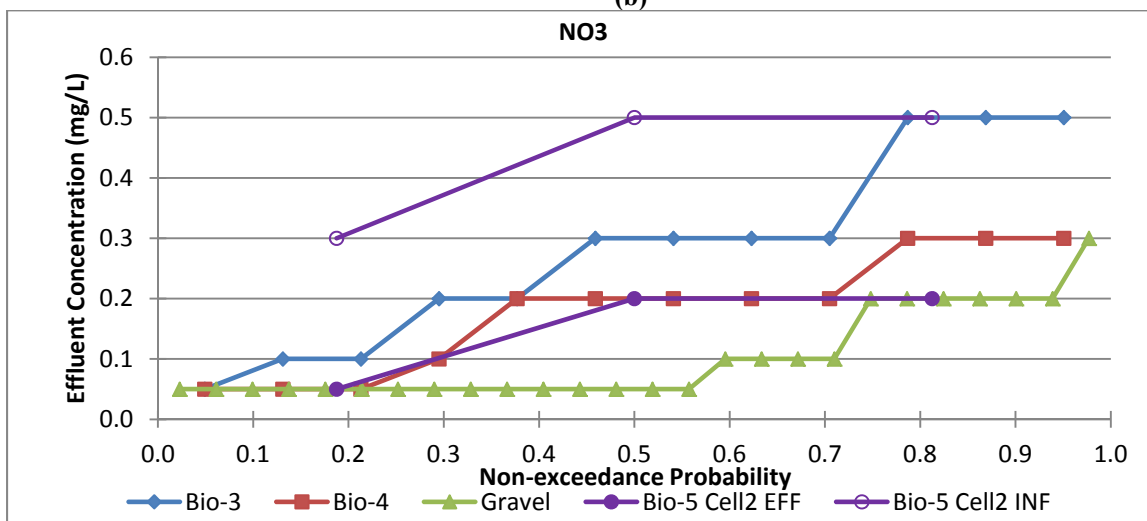
Total nitrogen influent and effluent concentrations both trend slightly upwards, with the exception of a single high influent concentration that does not appear to have affected the effluent concentrations (Figure 35b). More data may affirm that influent concentration holds little influence over effluent or reveal this data point as an outlier.



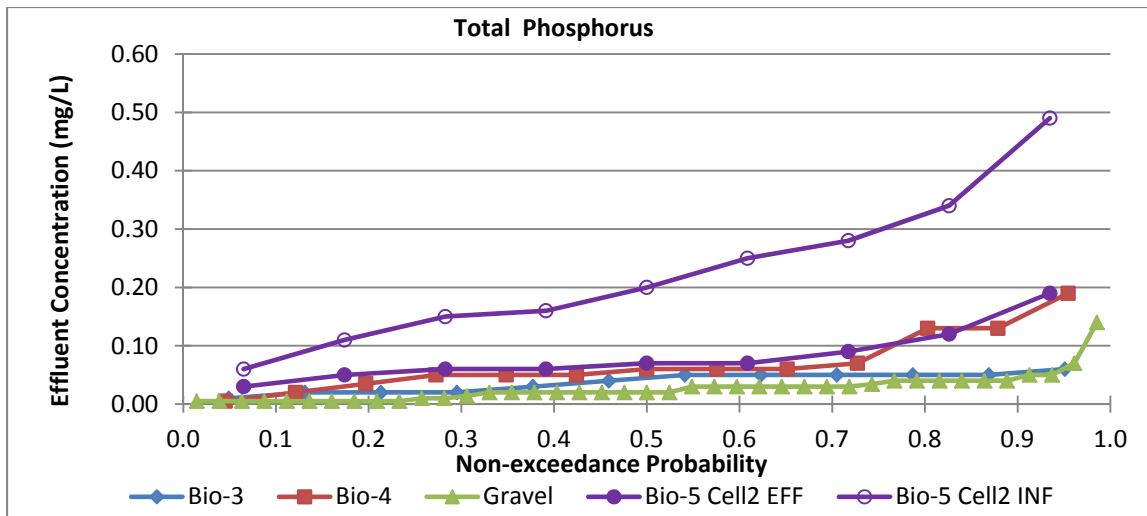
(a)



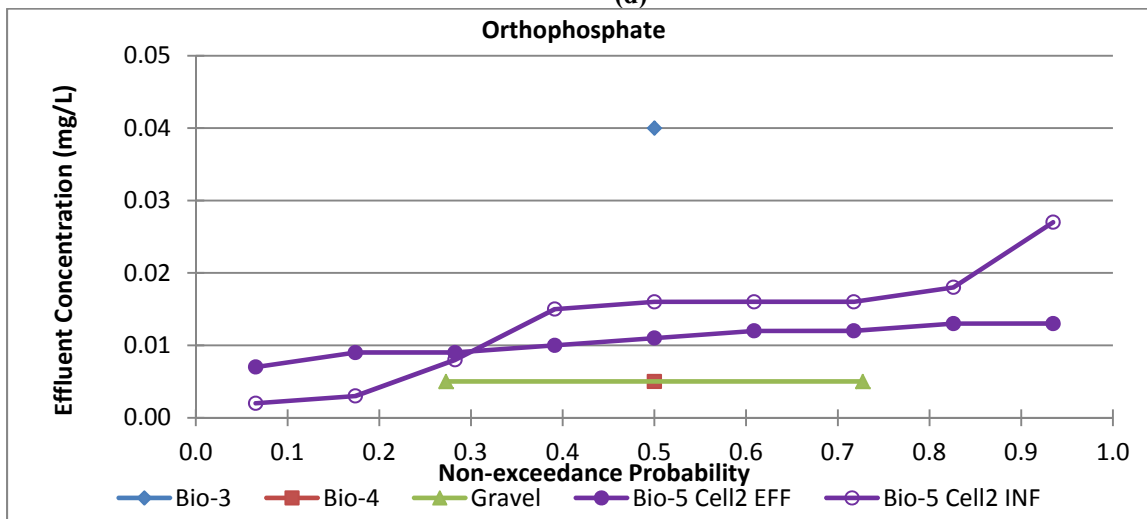
(b)



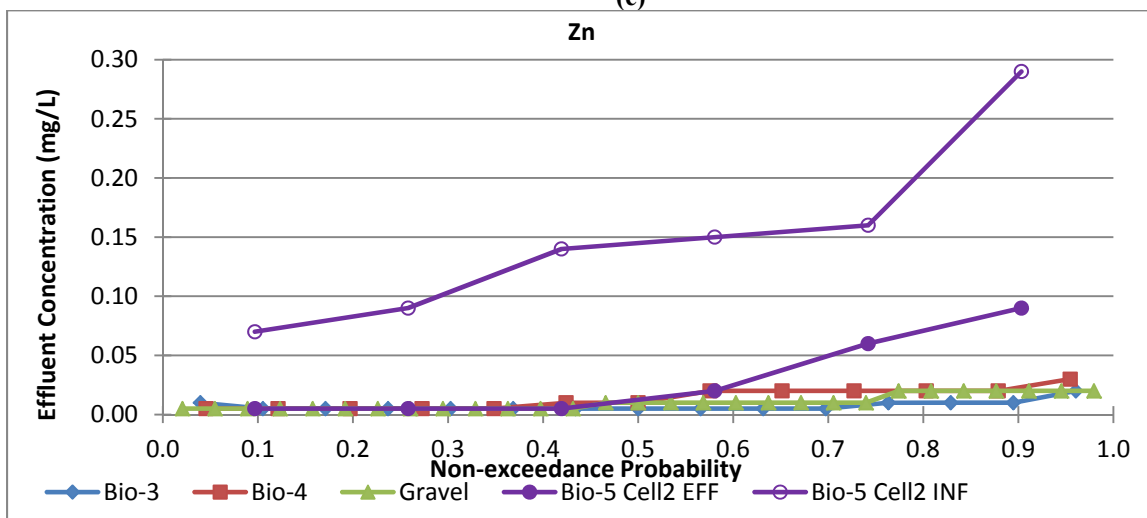
(c)



(d)



(e)



(f)

Figure 35. Cumulative distribution functions for 4 UNHSC vegetated systems.

## Treatment Effects on Nutrients

Some of the nutrient data is plotted with effluent concentration as the dependent variable upon the independent variable, influent concentration. As stated above, orthophosphate effluent concentrations hovered around 0.01 mg/L, even when influent concentrations were below that, causing some leaching (Figure 36). Unfortunately, other systems were not extensively monitored for orthophosphate, so a robust comparison cannot be made between them and Cell 2 of Bio-5. Much more TP data is available for comparisons, and it is plotted on a log-log scale so that the data spread can be seen. The only system to not leach total phosphorus into the effluent in any samples is Cell 2. The same goes for total nitrogen. Figure 38 also shows trendlines for the gravel wetland, Bio-5 Cell 2, and Bio-4. The nearly parallel trendlines between the gravel wetland and Cell 2 indicate similar behavior with respect to nitrogen between these two systems, as predicted. As noted above, Cell 2 does not attain quite the high performance for nitrogen as the gravel wetland, but it certainly shows good removal and great promise.

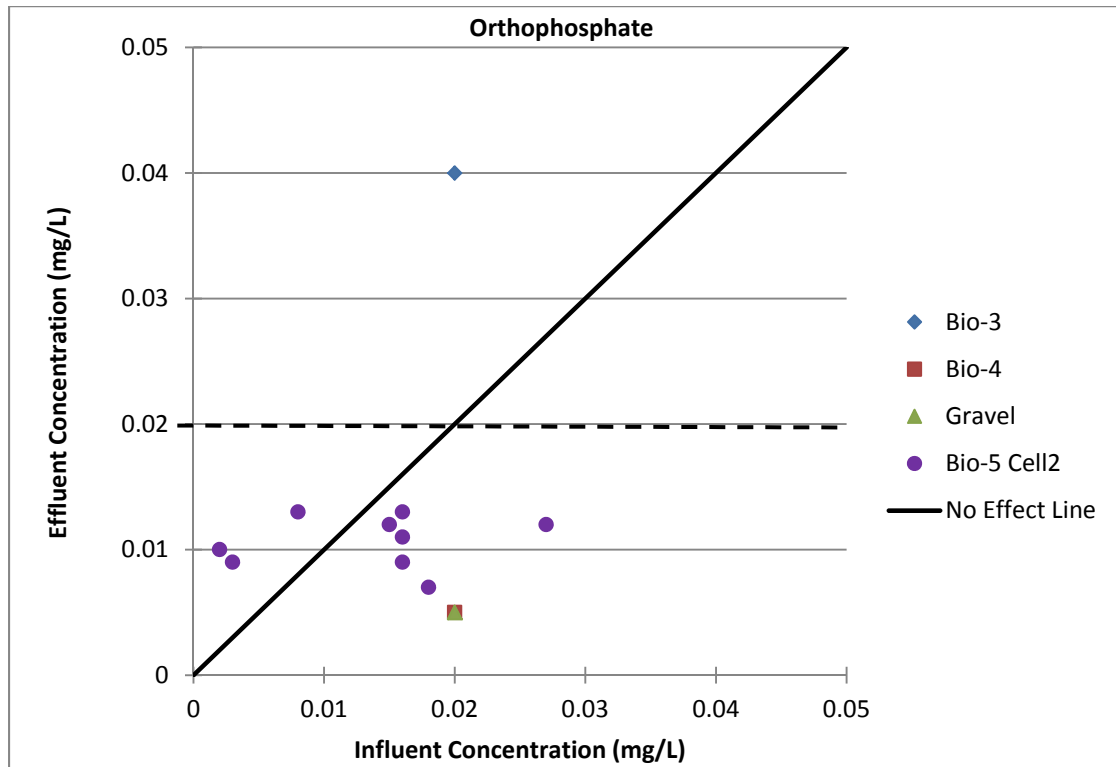
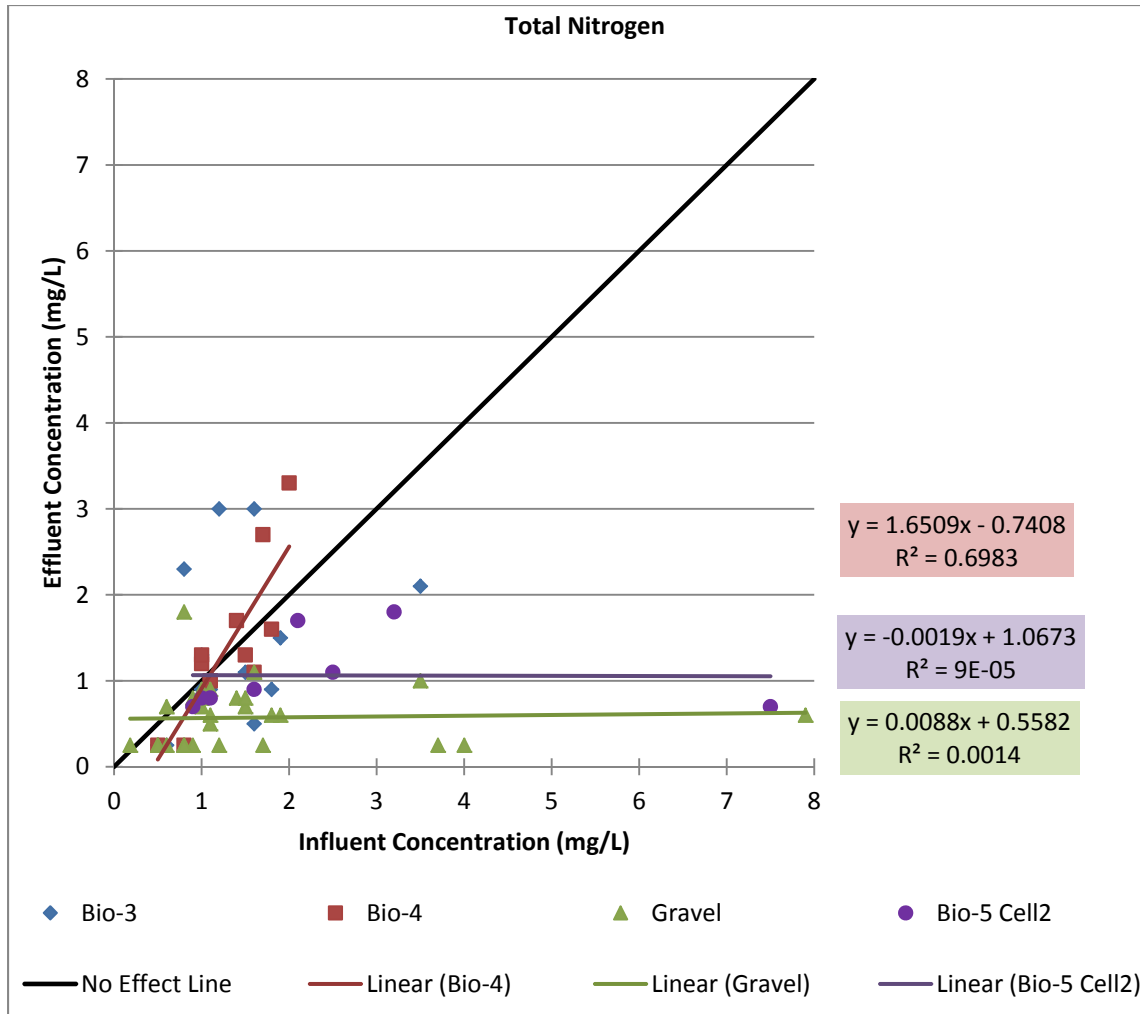


Figure 36. Treatment Effect Plot on OP for 4 UNH systems.





**Figure 38. Treatment Effect Plot on TN for 4 UNH systems.**

This data confirms that use of the internal storage reservoir in bioretention systems is effective. With improvements to the design, performance may be increased. Changes to the drainage area of Cell 2 may have altered the system, from its intended hydraulic capacity. Further, Cell 1 was designed with a larger ISR in order to compare results between the two designs and was expected to be the superior performer. The designs were for ISR to water quality volume ratios of 0.21 and 0.11 for Cells 1 and 2, respectively. Since data for Cell 1 was unusable and changes to the drainage area for Cell 2 altered its hydraulic load, the data presented here represents the performance of a ratio estimated to be <0.11. This is much less than the ratio of the subsurface gravel wetland, which is 0.26. The higher ratio is expected to achieve greater nitrogen removal due to increased internal storage reservoir and residence time. The minimum 30 foot horizontal travel path from the gravel wetland system is slightly reduced to approximately 22 feet in Bio-5, and the sizing of the ISR can likely be optimized to achieve greater performance from the modified bioretention system design.



**Table 18. Summary Statistics of UNHSC vegetated systems' performance for removal of TSS, Zinc, TN, Nitrate, TP, and Orthophosphate.**

	Name	N	ER	%RE					Effluent Concentration						
				Med %RE	95% CI		Mean %RE	SD	CV	Med Eff C	95% CI		Mean Eff C	SD	CV
TSS	Bio-3	15	97%	91%	88%	97%	90%	0.089	0.098	8	6	11	9	6.4	0.69
	Bio-4	9	94%	83%	63%	99%	83%	0.18	0.21	11	6	24	14	10.5	0.76
	Gravel Wetland	41	95%	91%	78%	95%	81%	0.24	0.29	5	5	5	9	16.8	1.96
	Bio-5 Cell 2	10	73%	81%	68%	95%	76%	0.22	0.29	18	8	74	39	43.1	1.12
Total Zn	Bio-3	15	74%	75%	50%	83%	70%	0.17	0.25	0.005	0.005	0.01	0.007	0.004	0.57
	Bio-4	13	57%	67%	25%	83%	53%	0.31	0.60	0.010	0.005	0.02	0.013	0.009	0.63
	Gravel Wetland	29	79%	80%	67%	83%	70%	0.23	0.33	0.010	0.005	0.010	0.010	0.006	0.59
	Bio-5 Cell 2	6	81%	83%	36%	98%	76%	0.25	0.33	0.010	0.005	0.090	0.028	0.034	1.21
TN	Bio-3	14	2%	24%	-30%	50%	-4%	0.81	-18	1.00	0.50	2.10	1.304	0.96	0.73
	Bio-4	12	-8%	9%	-30%	31%	0%	0.41	-185	1.25	1.00	1.700	1.392	0.88	0.63
	Gravel Wetland	30	63%	54%	46%	69%	51%	0.45	0.88	0.60	0.25	0.700	0.572	0.36	0.63
	Bio-5 Cell 2	8	56%	36%	20%	56%	40%	0.24	0.60	0.90	0.70	1.700	1.100	0.43	0.39
NO3	Bio-3	12	46%	44%	0%	63%	30%	0.42	1.37	0.30	0.10	0.50	0.279	0.16	0.57
	Bio-4	12	31%	42%	0%	50%	31%	0.25	0.81	0.20	0.05	0.300	0.179	0.096	0.54
	Gravel Wetland	26	71%	75%	50%	83%	64%	0.28	0.44	0.05	0.05	0.100	0.102	0.074	0.73
	Bio-5 Cell 2	3	65%	60%	60%	83%	68%	0.13	0.20	0.20	0.05	0.200	0.150	0.087	0.58
TP	Bio-3	12	24%	20%	-150%	67%	-69%	1.92	-2.80	0.045	0.020	0.05	0.038	0.017	0.44
	Bio-4	13	6%	-18%	-100%	40%	-20%	0.69	-3.52	0.060	0.035	0.130	0.070	0.051	0.73
	Gravel Wetland	41	71%	57%	40%	75%	21%	1.30	6.20	0.020	0.020	0.030	0.027	0.024	0.90
	Bio-5 Cell 2	9	64%	55%	32%	72%	54%	0.27	0.50	0.070	0.050	0.120	0.081	0.045	0.56
OP	Bio-3	1	-100%	-100%	N/A	N/A	-100%	N/A	N/A	0.040	N/A	N/A	0.040	N/A	N/A
	Bio-4	1	75%	75%	N/A	N/A	75%	N/A	N/A	0.005	N/A	N/A	0.005	N/A	N/A
	Gravel Wetland	2	75%	75%	N/A	N/A	75%	0	0	0.005	N/A	N/A	0.005	0	0
	Bio-5 Cell 2	9	21%	20%	-200%	56%	-48%	1.56	-3.24	0.011	0.009	0.013	0.011	0.002	0.18

N= # of samples; ER = efficiency ratio; Med %RE =median removal efficiency; 95% CI=nonparametric confidence interval about the median with actual confidence ranging from 94-98%; Med Eff C =median effluent concentration (mg/L)SD=standard deviation; CV=coefficient of variation (see Appendix for calculation methods). Shaded cells are BDL.

## Summary of Field Results

The modified Durham bioretention system, Bio-5 Cell 2, exceeded the nutrient removal efficiencies of other UNHSC bioretention systems. It achieved 20% median removal of orthophosphate and 55% median removal of TP. Cell 2 was the only of the four vegetated systems examined to not leach TP for any monitored storms. It consistently removed TP in spite of high influent concentrations relative to those in other systems. Orthophosphate effluent concentrations out of Bio-5 Cell 2 were consistently well below the EPA recommended standard of 0.025 mg P/L, and were also below our standard of 0.02 mg P/L.

Compared to the SPU bioretention database, Bio-5 Cell 2 removal efficiencies are below the database median removals of 48% for OP and 57% for TP for all the reported studies. It should be noted, however, that for the subset of commercial parking land use, bioretention removals are much lower, with median removal efficiencies of -9% for OP and 25% for TP. The drainage area of the Bio-5 system in Durham is a highly trafficked commercial parking lot, which may most appropriately be compared to the systems built in similar land use drainage areas. The Bio-5 system exceeds the median performance of other systems in similar commercial parking land use watersheds. Most importantly, Bio-5 Cell 2 avoids leaching dissolved phosphorus, as do other systems in similar land use. The moderately good results of Cell 2 compared with laboratory results and published data in the SPU database may be improved by following the O'Neill and Davis (2012b) recommendations of a mix oxalate ratio of at least 20 to 40. Use of processed WTR may alleviate preferential flow around clumps of WTR by allowing more thorough mixing and even distribution of WTR within the bioretention soil mix.

The WTR sample (WTR2) added to the BSM installed in Bio-5 was air-dried in the summer months in an outdoor lagoon, with around 10% solids content. The WTR admixture to column study BSMs ranged from 5-33% solids, having undergone various methods of drying. Field studies indicated that phosphorus is sorbed by raw WTR-amended BSMs, but column studies indicate that more effective sorption may be accomplished with processed WTR.

Field data from this study produced an unfortunately small nitrate dataset; however, the data available demonstrates great improvement to TN and nitrate removal with the inclusion of an internal storage reservoir in bioretention structural design. The preliminary data suggests the ISR design proved effective within a bioretention system as well as the subsurface gravel wetland system. As hypothesized, the modified bioretention system with ISR mimicked the behavior of the subsurface gravel wetland with respect to nitrogen. Influent and effluent concentration trendlines were parallel in TN 1:1 plots, demonstrating good TN removal for both systems (Figure 38). The SPU bioretention database together with the Durham bioretention data confirm this method for increasing nitrogen removal in bioretention systems. The SPU database contained subsets of bioretention systems with and without internal storage reservoirs. Those with internal storage tended to remove TN and nitrate, while those without internal storage frequently exported TN and nitrate (Figure 7 and Figure 8).

## CONCLUSIONS AND FUTURE RESEARCH

### Conclusions

#### Optimization of Phosphorus Removal

Aluminum-based drinking water treatment residuals as an admixture to bioretention soil mix effectively adsorbed phosphorus in laboratory and field studies. The unamended control mix was the only mix in three phases of column studies to leach orthophosphate; mixes amended with WTR consistently achieved >50% removal efficiency. Comparable bioretention soil mixes in field systems monitored by the UNH Stormwater Center (Bio-3 and Bio-4) also leached OP and/or TP on some occasions. The Bio-5 modified bioretention system with WTR-amended BSM and internal storage reservoir design consistently removed TP and produced low effluent OP concentrations (<0.02 mg P/L). These results lead to the conclusion that WTR applied at rates used in this study effectively adsorb orthophosphate.

While sorption capacity measures of Durham WTR were on the low end compared to others reported in literature (Table 10), phosphorus removal in columns with Durham WTR-amended BSMs was very good. Median removal efficiencies in column studies with filter media containing at least 10% WTR by volume ranged from 86% to 99% (Figure 27). This performance was achieved although the four samples of WTR tested from the Durham treatment plant had median  $P_{\max}$  of only 1.0 mg P/g WTR. This is a low  $P_{\max}$  compared to the median of  $P_{\max}$  values reported from literature as 7.4 mg P/g WTR (Figure 25 through Figure 28). Isotherm models generally overpredicted performance of BSMs in column and field studies.

The intent of this study was to evaluate the addition of WTR to BSMs in a mostly raw form, to make use of a waste product, avoid the expense of processing WTR, and to preserve the phosphorus sorption capacity (PSC) of WTR. In order to achieve a form that is solid enough to be added to BSMs, two samples of raw WTR for this study were either air-dried in the lagoon or partially dried in a low oven to achieve 5-10% solids content, while two other samples were further dewatered by a freeze-thaw process to 30-40% solids. WTR with <5% solids cannot be practically added to BSMs. Volumetric additions of raw WTR (5-10% solids) that exceeded 10% of the overall mix led to a very wet mix that is not recommended for use. These constraints on the use of raw WTR leads to very low content of adsorbent WTR sediments present in raw WTR-amended BSMs.

In column studies, BSMs containing at least 10% WTR by volume (at solids contents between 5-33%) consistently maintained high OP removal efficiencies, with median RE ranging from 86% to 99% (Figure 27). The modified bioretention system (Bio-5) installed in Durham, NH contained a filter media with 10% raw WTR by volume amendment and achieved median RE of only 20% for OP and 55% for TP (Figure 33). The cause of reduced performance in the field system is postulated to be the result of short-circuiting due to curb cut placement and preferential flows due to incomplete mixing of filter media. The high moisture content of raw WTR compared to other BSM constituents leads to clumping that can be difficult to break up with current field mixing methods. Processed WTR have moisture contents similar to those of compost or loam, which may enable more thorough mixing of the BSM.

Although the Bio-5 field system achieved moderate P removal with the addition of the raw WTR at ~9% solids, performance would likely improve with the addition of a WTR that has been processed to a higher solids content. The freeze-thaw dewatered WTR sample (WTR1) for this study proved the most effective adsorbent of OP. This method effectively increased the solids content of WTR1 to about 33%, and mixes containing this processed WTR as an admixture were the top column performers with consistent removal efficiencies of 98-99% (Figure 25). Resolution of mixing issues and higher WTR solids content present in a BSM amended with processed WTR (30-40% solids content) is expected to produce higher OP removals in the field as it did in column studies. The freeze-thaw dewatering method requires more space and appropriate conditions than simple air drying, but is more effective at increasing solids content of WTR and preserving its PSC.

### **Optimization of Nitrogen Removal**

The Bio-5 Cell 2 system achieved median removal efficiencies of 60% for nitrate and 36% for total nitrogen. Efficiency ratios, which are more resistant to extreme influent and/or effluent values, were 67% and 54% for NO<sub>3</sub> and TN, respectively. Nitrate data is based on data from only three storms. This performance demonstrates improvement over the standard bioretention design used by UNHSC to build the Bio-3 and Bio-4 systems. Nitrogen removal in Bio-5 does not reach the level of the gravel wetland, but it does approach it. Bio-5 Cell 2 encountered several issues related to reduced performance, including plant death and hydraulics altered from the design. The system had just one growing season during its monitoring period, and the lack of plant establishment likely contributed to reduced performance for both nitrogen and phosphorus removal. Nitrogen performance may also be improved by avoiding a sloped surface to allow for greater ponding depth throughout the system and increasing the ration of internal storage volume (VISR) to the water quality volume (WQV). Hydraulic issues, including short-circuiting, limited the performance of Bio-5 for nitrogen removal.

The Bio-5 Cell 2 in Durham provides modest insight into ISR sizing and flow path. Additional monitoring of the parallel Bio-5 Cell 1 and Cell 2 systems, as well as construction and monitoring of similar systems with the hydraulic issues resolved, is needed. Despite the issues, the 60% median nitrate removal efficiency in Cell 2 indicates a 15-46% improvement of performance over typical bioretention design. Median removal efficiencies of bioretention systems in the SPU database is 14%, while other UNH bioretention systems have a median removal efficiency of around 40% for nitrate. Even small improvements can add up to significant savings on nutrient load at the watershed level. These results are very promising.

### **BSM and ISR Design Recommendations for Optimized Nutrient Removal**

Results of this study support the hypothesis that optimization of nutrient removal may be achieved in a modified bioretention system with an ISR with appropriate specifications to promote denitrification and the addition of WTR to the bioretention soil mix to adsorb phosphorus. WTR amendments should be characterized by soil tests that include at minimum a P saturation index or oxalate ratio (O'Neill and Davis 2012b). A 10% by volume application rate of processed WTR as an admixture to BSMs is recommended. WTR should contain no less than 10% solids, more likely ~33%. Infiltration rates of mixes should be tested prior to use in

constructed bioretention systems to ensure draindown time will not be excessively long. The volumetric application of WTR at 10% of the overall mix may be reduced when high solids WTR are used (>30% solids). Mixes should also undergo soil tests that include an oxalate ratio to ensure that the O'Neill and Davis (2012) criterion of minimum oxalate ratio of 20-40 is met.

Loam content of 10-20% of the BSM by volume was used and approved to support plants and provided some additional phosphorus sorption capacity to the overall mix ( $P_{\max} = 0.97$  mg P/g loam). Further studies are needed to confirm the role of loam as a phosphorus sorbent, and characterization similar to that of WTR is recommended before using it as such.

A significant finding was that compost as a BSM component was a source of nutrient leaching. The Langmuir isotherm predicted compost to leach at a rate as high as 1.74 mg P/ g compost (Table 6), compared to sorption capacities of WTR from 0.47 to 3.37 mg P/ g WTR. Compost characterization is important if it is used, including measures such as P saturation index and C:N ratio to determine its leachability. If compost is added to a BSM to support plants, an application rate of no more than 10% by volume is recommended, based on results of this study. Wood chips may reduce the need for compost to support plant growth by providing long term organic matter to the system. They also provide structure to the soil mix that helps to maintain high infiltration rates. Contact times of at least 10 minutes are recommended by Pitt and Clark (2010), which column study results of this project corroborate.

An optimal ISR design in a bioretention system should closely mimic that of the subsurface gravel wetland in terms of size. The 22-30 foot subsurface flow path length should be maintained as much as possible given site constraints, and a VISR/WQV ratio of at least 0.1 is recommended. The smaller VISR/WQV ratio of Bio-5 Cell 2, estimated to be around 0.11, as compared to that of the subsurface gravel wetland (VISR/WQV = 0.26), may account for the somewhat reduced performance of Bio-5 Cell 2. To optimize the design, further studies should be undertaken with construction and monitoring of systems with ratios of 0.2-0.3 and resolution of the hydraulic issues present in Bio-5.

## **Future Research**

Further research is needed to expand the standards for WTR use as an admixture in bioretention filter media, which should include recommendations on all of the following: 1) PSC, as defined by the Langmuir model, reactive aluminum content, or oxalate ratio, 2) solids content and/or standard dewatering method to determine appropriate texture, and 3) amount to be added as a percent of the total BSM. The Langmuir model developed from the BSM isotherm experiment was the best predictor of relative column performance between mixes in the present study, although accurate prediction could not be determined without running the columns to breakthrough. A standard Langmuir  $P_{\max}$  range or reactive aluminum content, as these two measures have been shown to be correlated (Dayton et al. 2003), should be established. Further research can confirm and/or refine the recommendation of O'Neill and Davis of an oxalate ratio of at least 20 to 40. Consideration should be given to the best prediction of field performance as well as ease of acquiring data to determine the suitability of a particular WTR sample. Should aluminum content or oxalate ratio be chosen as the standard, it would also be useful to consider how Mehlich 3 extraction compares to oxalate extraction, since Mehlich 3 extraction may be a more accessible standard soil test than oxalate extraction.

Since raw WTR often have <1% solids content and sorption capacity is based on dry mass of adsorbent, it is important to also define the appropriate solids content for WTR use as an admixture. Results of column studies and field data from this project led to the recommendation of a minimum of 10% solids content, with preference for ~33%. However, a more refined approach may be able to optimize the solids content. Finally, a standard amount based on the PSC and solids content that is appropriate to add as a fraction of the BSM should be established. It is most practical to determine the fraction by volume, as this is how it will be added to the mixture when prepared for a field installation. Given standard solids content and PSC, an appropriate standard volume fraction of total BSM can be developed. These recommendations may serve as guidance for commercialization of dried and processed WTR.

Another benefit of using processed WTR is that thorough mixing may be accomplished more easily since WTR will have more similar solids contents to the other components with which it is being mixed. Higher solids content WTR is less likely to clump than raw WTR. To ensure thorough mixing such that the adsorbent material is evenly distributed throughout the filter media, some alternative field mixing methods should be explored. For example, a concrete mixer or a commercial grade mixer would likely prove more effective than a backhoe at mixing the filter media. These methods may improve uniformity of WTR distribution throughout filter media to the degree that performance of the filter media is increased.

The use of compost in systems optimized for nutrient removal is not recommended due to the risk of leaching nutrients. However, composts are highly variable and a greater understanding of the parameters that cause compost to leach nutrients in a bioretention system may allow for standards to be developed. Current standards do not appear to be adequate to avoid leaching of nutrients from compost-containing bioretention systems. A recent study in Redmond, WA resulted in very high nutrient export from a system using USCC certified compost meeting all regional guidance standards (Herrera Environmental Consultants 2012, [ENREF 15](#)).

Sizing of filter beds based on PSC analysis should be investigated further. A more complete component PSC analysis may be compared with mix PSC analyses and more robust column studies to determine the relationship of isotherm models to column performance. Since sorption capacities of materials will vary, filter bed sizing based on the experimentally determined capacity of a filter media may avoid oversizing of bioretention systems or failed systems due to undersizing.

More research is also needed for the sizing of internal storage reservoirs (ISR). The parallel systems in Durham with identical specifications except for internal storage reservoir size should have allowed for the investigation of ISR size. However, in the course of this study, failure of vegetation establishment, timing of monitored storms, hydraulic issues, and small datasets led to inadequate comparison. More data is needed to confirm the findings from monitoring of the Durham bioretention and other published research that ISRs significantly improve bioretention nitrogen performance. Nitrogen has become a very significant contaminant of concern in recent years, and further monitoring of the Durham bioretention and other systems like them will shed more light on the design of such systems and the nitrogen transformations occurring within them.

## REFERENCES

- Bache, B. W., and Williams, E. G. (1971). "A phosphate sorption index for soils." *European Journal of Soil Science*, 22(3), 289-301.
- Blecken, G. T., Zinger, Y., Muthanna, T. M., Deletic, A., Fletcher, T. D., and Viklander, M. (2007). "The influence of temperature on nutrient treatment efficiency in stormwater biofilter systems." *Water science and technology : a journal of the International Association on Water Pollution Research*, 56(10), 83-91.
- Carpenter, S. R., Caraco, N. F., Correll, D. L., Howarth, R. W., Sharpley, A. N., and Smith, V. H. (1998). "Nonpoint Pollution of Surface Waters with Phosphorus and Nitrogen." *Ecological Applications*, 8(3), 559-568.
- Conley, D. J., Paerl, H. W., Howarth, R. W., Boesch, D. F., Seitzinger, S. P., Havens, K. E., Lancelot, C., and Likens, G. E. (2009). "Controlling Eutrophication: Nitrogen and Phosphorus." *Science*, 323, 1014-1015.
- Crittenden, J., Trussell, R. R., Hand, D. W., Howe, K. J., and Tchobanoglous, G. (2005). "Water Treatment: Principles and Design." John Wiley & Sons, Inc., Hoboken, NJ.
- Davis, A. P., Traver, R. G., and Hunt, W. F. (2010). "Improving Urban Stormwater Quality: Applying Fundamental Principles." *Journal of Contemporary Water Research and Education*, 146, 3-10.
- Dayton, E. A., and Basta, N. T. (2005). "A Method for Determining the Phosphorus Sorption Capacity and Amorphous Aluminum of Aluminum-Based Drinking Water Treatment Residuals Salaries and support provided by state and federal funds appropriated to the Ohio Agricultural Research and Development Center, The Ohio State University, Columbus, OH 43210." *J. Environ. Qual.*, 34(3), 1112-1118.
- Dayton, E. A., Basta, N. T., Jakober, C. A., and Hattey, J. A. (2003). "Using Treatment Residuals to Reduce Phosphorus in agricultural runoff." *Journal (American Water Works Association)*, 95(4), 151-158.
- Elliott, H. A., O'Connor, G. A., Lu, P., and Brinton, S. (2002). "Influence of Water Treatment Residuals on Phosphorus Solubility and Leaching." *Journal of Environmental Quality*, 31(4), 1362-1369.
- Gallimore, L. E., Basta, N. T., Storm, D. E., Payton, M. E., Huhnke, R. H., and Smolen, M. D. (1999). "Water Treatment Residual to Reduce Nutrients in Surface Runoff from Agricultural Land." *Journal of Environmental Quality*, 28(5), 1474-1478.
- Hathaway, A. M., Hunt, W. F., and Jennings, G. D. (2008). "A Field Study of Green Roof Hydrologic and Water Quality Performance." *American Society of Agricultural and Biological Engineers*, 51(1), 31-44.

Hatt, B. E., Fletcher, T. D., and Deletic, A. (2007). "Hydraulic and Pollutant Removal Performance of Stormwater Filters Under Variable Wetting and Drying Regimes." *Water Science and Technology*, 56(12), 11-19.

Helsel, D. R., and Hirsch, R. M. (2002). "Statistical Methods in Water Resources: Techniques of Water Resources Investigations." U.S. Geological Survey, 522.

Henderson, C., Greenway, M., and Phillips, I. (2007). "Removal of dissolved nitrogen, phosphorus and carbon from stormwater by biofiltration mesocosms." *Water science and technology : a journal of the International Association on Water Pollution Research*, 55(4), 183-191.

Herrera Environmental Consultants, Inc., (2012). "Pollutant Export From Bioretention Soil Mix: 185th Avenue NE, Redmond, Washington." Redmond, WA.

Howarth, R. W., and Marino, R. (2006). "Nitrogen as the Limiting Nutrient for Eutrophication in Coastal Marine Ecosystems: Evolving Views over Three Decades." *Limnology and Oceanography*, 51(1), 364-376.

Hsieh, C.-h., and Davis, A. P. (2005). "Evaluation and Optimization of Bioretention Media for Treatment of Urban Storm Water Runoff." *Journal of Environmental Engineering*, 131(11), 1521-1531.

Hsieh, C.-h., Davis, A. P., and Needelman, B. A. (2007). "Bioretention Column Studies of Phosphorus Removal from Urban Stormwater Runoff." *Water Environment Research*, 79(2), 177-184.

Jacobs, J. M., Lowry, B., Choi, M., and Bolster, C. H. (2009). "GOES Solar Radiation for Evapotranspiration Estimation and Streamflow Prediction." *Journal of Hydrologic Engineering*, 14(3), 293-300.

Kinniburgh, D. G. (1986). "General purpose adsorption isotherms." *Environmental Science & Technology*, 20(9), 895-904.

Lucas, W., and Greenway, M. (2011a). "Phosphorus Retention by Bioretention Mesocosms Using Media Formulated for Phosphorus Sorption: Response to Accelerated Loads." *Journal of Irrigation and Drainage Engineering*, 137(3), 144-153.

Lucas, W. C., and Greenway, M. (2011b). "Hydraulic Response and Nitrogen Retention in Bioretention Mesocosms with Regulated Outlets: Part II - Nitrogen Retention." *Water Environment Research*, 83.

Makris, K. C., El-Shall, H., Harris, W. G., O'Connor, G. A., and Obreza, T. A. (2004). "Intraparticle phosphorus diffusion in a drinking water treatment residual at room temperature." *Journal of Colloid and Interface Science*, 277, 417-423.



- McLaughlin, J. R., Ryden, J. C., and Syers, J. K. (1981). "Sorption of Inorganic Phosphate by Iron- and Aluminum-containing Components." *European Journal of Soil Science*, 32, 365-377.
- Mead, J. A. (1981). "A comparison of the Langmuir, Freundlich and Temkin equations to describe phosphate adsorption properties of soils." *Soil Research*, 19(3), 333-342.
- Mitsch, W. J., and Gosselink, J. G. (2000). "The value of wetlands: importance of scale and landscape setting." *Ecological Economics*, 35(1), 25-33.
- Moazed, H., Hoseini, Y., Naseri, A. A., and Abbasi, F. (2010). "Determining phosphorus adsorption isotherm in soil and its relation to soil characteristics." *Journal of Food, Agriculture and Environment*, 8(2), 1153-1157.
- Moore, P. A., Jr., Daniel, T. C., and Edwards, D. R. (1999). "Reducing Phosphorus Runoff and Improving Poultry Production with Alum." *Poultry Science*, 78(692-698).
- Nash, J. E., and Sutcliffe, J. V. (1970). "River flow forecasting through conceptual models. Part 1 - A discussion of principles." *Journal of Hydrology*, 10(3), 282-290.
- National Climatic Data Center, NOAA's 1981-2010 Climate Normals,. (2013). "Average Annual Precipitation for New Hampshire." -. C. R. Nexus, ed.
- Novak, J. M., and Watts, D. W. (2004). "Increasing the Phosphorus Sorption Capacity of Southeastern Coastal Plain Soils Using Water Treatment Residuals." *Soil Science*, 169(3), 206-214.
- O'Neill, S. W., and Davis, A. P. "Analysis of Bioretention Media Specifications and Relationships to Overall Performance." *World Environmental and Water Resources Congress 2009: Great Rivers*, Kansas City, MO, 840-848.
- O'Neill, S., and Davis, A. (2012a). "Water Treatment Residual as a Bioretention Amendment for Phosphorus. I: Evaluation Studies." *Journal of Environmental Engineering*, 138(3), 318-327.
- O'Neill, S., and Davis, A. (2012b). "Water Treatment Residual as a Bioretention Amendment for Phosphorus. II: Long-Term Column Studies." *Journal of Environmental Engineering*, 138(3), 328-336.
- Pitt, R., Chen, S.-E., and Clark, S. "Infiltration Through Compacted Urban Soils and Effects on Biofiltration Design." *Low Impact Development Roundtable Conference*, Baltimore, MD, 1-30.
- Pitt, R., and Clark, S. (2010). "Evaluation of Biofiltration Media for Engineered Natural Treatment Systems." Geosyntec Consultants, Santa Barbara, CA.

- Roseen, R. M., Ballesterio, T. P., Houle, J. J., Avellaneda, P., Wildey, R., and Briggs, J. F. (2006). "Performance evaluations for a range of stormwater LID, conventional structural, and manufactured treatment strategies for parking lot runoff under varied mass loading conditions." *Transportation Research Record: Journal of the Transportation Research Board*(No. 1984), 135–147.
- Roseen, R., Watts, A., Houle, J., Farah, K., and Ballesterio, T. (2010). "Investigation of Nutrient Removal Mechanisms of a Constructed Gravel Wetland Used for Stormwater Control in a Northern Climate." University of New Hampshire Stormwater Center New England Interstate Water Pollution Control Commission.
- Roseen, R. M., Hlas, V., Houle, J., and Dowling, R. (2011). "Design Drawings for Bioretention Systems for “Tedeschi” Municipal Lot Pettee Brook Lane, Durham NH." UNH Stormwater Center, Durha, NH, United States, 13pp.
- Roseen, R. M., Stone, R. M., Colwell, S., and Basketfield, S. (2013). "SPU Bioretention Database." R. M. Stone, ed.
- Sakadevan, K., and Bavor, H. J. (1998). "Phosphate adsorption characteristics of soils, slags and zeolite to be used as substrates in constructed wetland systems." *Water Research*, 32(2), 393-399.
- Sansalone, J., and Ma, J. (2009). "Parametric Evaluation of Batch Equilibria for Storm-Water Phosphorus Adsorption on Aluminum Oxide Media." *Journal of Environmental Engineering*, 135(9), 737-746.
- Sanyal, S. K., Chan, P. Y., and De Datta, S. K. (1993). "Phosphate Sorption-Desorption Behavior of Some Acidic Soils of South and Southeast Asia." *Soil Sci. Soc. Am. J.*, 57(4), 937-945.
- Schindler, D. W., Hecky, R. E., Findlay, D. L., Stainton, M. P., Parker, B. R., Paterson, M. J., Beaty, K. G., Lyng, M., and Kasian, S. E. M. (2008). "Eutrophication of lakes cannot be controlled by reducing nitrogen input: Results of a 37-year whole-ecosystem experiment." *Proceedings of the National Academy of Sciences*, 105(32), 11254-11258.
- Stromberg, M. (2010). "Technical Memorandum: Regional Bioretention Soil Guidance and Model Specification Bay Area Stormwater Management Agencies Association." WRA Environmental Consultants, San Rafael, CA.
- UNH Stormwater Center, NOAA, and CICEET. (2012). "University of New Hampshire Stormwater Center 2012 Biennial Report." U. o. N. Hampshire, ed.
- USEPA Office of Water Regulations and Standards. (1986). "Quality Criteria for Water 1986." USEPA, Washington, DC.

Willmott, C. J. (1982). "Some Comments on the Evaluation of Model Performance."  
*Bulletin American Meteorological Society*, 63(11), 1309-1313.

## APPENDICES

<b>APPENDIX A</b> .....	<b>99</b>
ANALYTICAL METHODS .....	99
SOIL REPORTS .....	99
BSM COMPOSITION .....	99
<b>APPENDIX B</b> .....	<b>108</b>
BATCH EQUILIBRIUM STUDIES DATA .....	108
<b>APPENDIX C</b> .....	<b>121</b>
COLUMN STUDIES HYDRAULICS DATA.....	121
COLUMN STUDIES WATER QUALITY DATA .....	121
<b>APPENDIX D</b> .....	<b>130</b>
<b>APPENDIX E</b> .....	<b>144</b>
BIO-5 CELL 2 MONITORING DATA.....	144
BIO-5 CELL 1 MONITORING DATA.....	144
BIO-5 CELL 1 TIME SERIES FIGURES.....	144

# **APPENDIX A**

**Analytical Methods**

**Soil Reports**

**BSM Composition**

**Table 19. Absolute Resource Associates Laboratory analytical methods and expected detection limits for each analyte.**

Analyte	Analytical Method	Method Detection Limit (mg/L)
Total Dissolved Nitrogen (TKN, Nitrate, Nitrite)	SM4500 NH3F (filtered with 0.45 micron filter)	MDL: NA, calculation RL: 0.5 mg/L
Particulate Nitrogen (TKN, Nitrate, Nitrite)	SM4500 NH3F	MDL: NA, calculation RL: 0.5 mg/L
Ammonia	EPA 350	MDL: 0.107 mg/L RL: 0.5 mg/L
Nitrate	EPA 300.0	MDL: 0.02 mg/L RL: 0.1 mg/L
Nitrite	EPA 300.0	MDL: 0.037 mg/L RL: 0.1 mg/L
TKN	ASTMD359002A	MDL: 0.178 mg/L RL: 0.5 mg/L
Total Phosphorus	EPA 365.3	MDL: 0.009 RL: 0.01 mg/L
Total Dissolved Phosphorus	EPA 365.3 (filtered with 0.45 micron filter)	MDL: 0.009 RL: 0.01 mg/L
Ortho-Phosphate	EPA 365.1 or 300.0	MDL: 0.007 mg/L RL: 0.001 mg/L or 0.01 mg/L
Total Suspended Solids	SM2540D	MDL: 0.445 mg/L RL: 1 mg/L
Metals (Al)	EPA 6010	MDL: 0.002 mg/L RL: 0.05 mg/L
Metals (Cu)	EPA 6010	MDL: 0.001 mg/L RL: 0.05 mg/L
Metals (Fe)	EPA 6010	MDL: 0.002 mg/L RL: 0.05 mg/L
Metals (Zn)	EPA 6010	MDL: 0.001 mg/L RL: 0.05 mg/L

**Table 20. Analytical Services Laboratory analytical methods and expected performance data for each analyte.**

*Note that all detection limits are dependent upon adequate sample volume. Several of these analyses measure ratios or capacities, and do not have an applicable detection limit. NA=No applicable DL.*

Analyte	Method	Reference	Method Detection Limit
Lime requirement	Mehlich buffer	Mehlich, A. 1976. New buffer pH method for rapid estimation of exchangeable acidity and lime requirement of soils. <i>Commun. Soil Sci. Plant Analysis</i> . 7, 637-652.	NA
Available P, K, Ca, and Mg	Mehlich 3 (ICP)	Wolf, A.M. and D.B. Beegle. 1995 Recommended soil tests for macronutrients: phosphorus, potassium, calcium, and magnesium. p. 25-34. <i>In</i> J. Thomas Sims and A. Wolf (eds.) Recommended Soil Testing Procedures for the Northeastern United States. Northeast Regional Bulletin #493. Agricultural Experiment Station, University of Delaware, Newark, DE.	0.5 mg/kg in soil (dry weight)
Cation Exchange Capacity (CEC)	Summation	Ross, D. 1995. Recommended soil tests for determining soil cation exchange capacity. p. 62-69. <i>In</i> J. Thomas Sims and A. Wolf (eds.) Recommended Soil Testing Procedures for the Northeastern United States. Northeast Regional Bulletin #493. Agricultural Experiment Station, University of Delaware, Newark, DE.	NA
Organic matter	Loss on Ignition	Schulte, E.E. 1995. Recommended Soil Organic Matter Tests. p. 47-56. <i>In</i> J. Thomas Sims and A. Wolf (eds.) Recommended Soil Testing Procedures for the Northeastern United States. Northeast Regional Bulletin #493. Agricultural Experiment Station, University of Delaware, Newark, DE.	NA
Total C	Combustion	Nelson, D.W. and L.E. Sommers. 1996. Total Carbon, Organic Carbon, and Organic Matter. p 961-1010. <i>In</i> D.L. Sparks (ed). <i>Methods of Soil Analysis, Part 3. Chemical Methods</i> . Soil Science Society of America Book Series Number 5. American Society of Agronomy, Madison, WI. Pella, E. 1990. Elemental organic analysis. Part 1. <i>Am. Lab</i> 22: 116-125	0.7 mg in soil (dry weight)
Nitrate N	Specific Ion Electrode	Griffin, G. 1995. Recommended Soil Nitrate-N Tests. p. 17-24. <i>In</i> J. Thomas Sims and A. Wolf (eds.) Recommended Soil Testing Procedures for the Northeastern United States. Northeast Regional Bulletin #493. Agricultural Experiment Station, University of Delaware, Newark, DE.	1 mg/kg in soil (dry weight)
Ammonium N	Specific Ion Electrode	Mulvaney, R.L. 1996. Nitrogen-Inorganic Forms. p. 1123-1200. <i>In</i> D.L. Sparks (ed). <i>Methods of Soil Analysis, Part 3. Chemical Methods</i> . Soil Science Society of America Book Series Number 5. American Society of Agronomy, Madison, WI.	1 mg/kg in soil (dry weight)
Total N	Combustion	Bremner, J.M.. 1996. Nitrogen-Total. p. 1085-1121. <i>In</i> D.L. Sparks (ed). <i>Methods of Soil Analysis, Part 3. Chemical Methods</i> . Soil Science Society of America Book Series Number 5. American Society of Agronomy, Madison, WI. Pella, E. 1990. Elemental organic analysis. Part 1. <i>Am. Lab</i> 22: 116-125	0.05 0.7 mg in soil (dry weight)
Soluble Salts	Electrical Conductivity (1:2)	Gartley, Karen. 1995. Recommended Soluble Salts Tests. p. 70-75. <i>In</i> J. Thomas Sims and A. Wolf (eds.) Recommended Soil Testing Procedures for the Northeastern United States. Northeast Regional Bulletin #493. Agricultural Experiment Station, University	NA

		of Delaware, Newark, DE.	
Total Sorbed Cu, Zn, Pb, Ni, Cd, Cr, Mo, As, Se, Hg	EPA Method 3050B/3051 + 6010	USEPA. 1986. Test Methods for Evaluating Solid Waste. Volume IA: 3rd Edition. EPA/SW-846. National Technical Information Service. Springfield, Va.	As, Se, Cu, Mo =0.015 Cd, Cr, Ni =0.005 Zn =0.008 Pb =0.02
Particle Size Analysis	Hydrometer Method	Gee, G.W. and J.W. Bauder. 1986. Particle size analysis. p. 383-411. <i>In</i> A. Klute (ed.) Methods of Soil Analysis. Part 1. Physical and Mineralogical Methods. Agronomy Monograph #9 (2nd Edition). Amer. Soc. Agron. Madison, WI.	NA
Calcium carbonate equivalency (CCE)	ASTM Method C 25	Standard Test Methods for Chemical Analysis of Limestone, Quicklime, and Hydrated Lime, ASTM International, 100 Barr Harbor Drive, PO Box C700, West Conshohocken, PA	NA



**Table 21. Biosolids and Septage Spreading Soil Reports.**

Date	11-Feb	11-Sep	12-Apr	12-Jun	11-Feb	12-Jun	11-Feb	11-Feb	11-Aug
Name	WTR1	WTR2	WTR3	WTR4	Compost1	Compost2	Loam	Sand	Durham Bio
Sample ID	WTR 16744	WTR 16734	WTR 16775	WTR 16779	Compost 16742	MelComp 16780	Loam 16740	Sand 16738	BSMTED 16737
Target pH	6.00	6.00	6.00	6.00	6.00	6.00	6.00	6.00	6.00
pH - Soil (pH)	6.9	6.4	6.4	6.7	6.9	7.2	6.7	6.8	7.3
Mehlich - Lime Test (Buffer pH)	6.60	6.40	6.40	6.70	6.40	7.00	6.50	6.50	7.00
Ca, Mehlich 3 (ppm)	165.1	210.5	151.5	577.1	3008.2	3903.4	914.2	160.4	942.6
Mg, Mehlich 3 (ppm)	28.0	26.0	19.0	31.0	621.0	527.0	106.0	40.0	133.0
K, Mehlich 3 (ppm)	27.0	25.0	38.0	30.0	1217.0	1121.0	183.0	23.0	222.0
P, Mehlich 3 (ppm) (mg/kg)	8.0	7.0	4.0	2.0	853.0	252.0	121.0	35.0	90.0
% Organic Matter	26.99%	24.69%	31.33%	25.56%	28.09%	16.31%	1.23%	0.00%	2.09%
Est. CEC	1.13	2.63	2.31	3.22	24.64	26.78	6.02	1.29	6.39
Est. Base Sat.	100.00%	50.63%	42.80%	100.00%	94.72%	100.00%	98.34%	92.27%	100.00%
Est. Ca Sat.	73.18%	39.97%	32.75%	89.59%	61.05%	72.87%	75.89%	61.96%	73.75%
Est. Mg Sat.	20.68%	8.23%	6.84%	8.02%	21.01%	16.40%	14.66%	25.75%	17.34%
Est. K Sat.	6.14%	2.43%	4.21%	2.39%	12.67%	10.73%	7.79%	4.56%	8.91%
Est. P Sat.	0.34%	0.37%	0.16%	0.07%	140.92%	37.73%	7.44%	4.59%	5.78%
Al, Mehlich 3 (ppm) (mg/kg)	2000.9	1588.0	2050.0	2330.0	408.4	448.0	1291.3	619.3	1292.0
Fe, Mehlich 3 (ppm) (mg/kg)	157.1	109.0	132.0	139.0	246.4	276.0	258.5	93.8	135.0

**Table 22. Compost Soil Reports Part 1.**

	<b>WTR</b>		<b>WTR2</b>		<b>WTR3</b>		<b>WTR4</b>	
	<b>WTR16745</b>		<b>WTR16735</b>		<b>WTR16776</b>		<b>WTR 16777</b>	
	<b>As is basis</b>	<b>Dry wt. basis</b>	<b>As is basis</b>	<b>Dry wt. basis</b>	<b>As is basis</b>	<b>Dry wt. basis</b>	<b>As is basis</b>	<b>Dry wt. basis</b>
<b>pH, SME (pH)</b>	6.70		6.80		6.30		6.70	
<b>Sol. Salts, 1:2, v/v (EC) (mmhos/cm)</b>	0.23		0.21		0.15		0.32	
<b>Dry Matter (DM)</b>	9.60%		18.90%		4.90%		47.70%	
<b>Nitrogen (N)</b>	0.00%	0.0%	0.10%	0.5%	0.00%	0.0%	0.30%	0.6%
<b>Organic Matter, LOI-550 (OM)</b>	3.50%		8.00%		2.10%		16.60%	
<b>Est. Organic-C (OrganicC)</b>	1.70%	17.7%	3.20%	16.9%	1.00%	20.4%	760.00%	15.9%
<b>Est. C/N ratio (CNRatio)</b>	44.80		24.30		20.60		22.80	
<b>Phosphorus, total (P2O5)</b>	0.02%	0.2%	0.04%	0.2%	1.00%	0.2%	0.09%	0.2%
<b>Potassium, total (K2O)</b>	0.02%	0.2%	0.04%	0.2%	1.00%	0.2%	0.11%	0.2%
<b>NH4-N, SME (NH4-N) (ppm)</b>	7.60	79.2	1.90	12.1	1.90	38.8	2.40	5.0
<b>Aluminum, total (Al) (ppm)</b>	8389.00	87385.4	21686.00	114740.7	7607.00	155244.9	61226.00	128356.4
<b>Calcium, total (Ca) (%)</b>	0.01%	0.1%	0.03%	0.2%	1.00%	0.2%	0.13%	0.3%
<b>Magnesium, total (Mg) (%)</b>	0.02%	0.2%	0.03%	0.2%	1.00%	0.2%	0.09%	0.2%
<b>Sodium, total (Na) (ppm)</b>	27.00	281.2	65.00	343.9	20.00	408.2	60.00	125.8
<b>Copper, total (Cu) (ppm)</b>	1.70	17.7	4.20	22.2	0.90	18.4	14.10	29.6
<b>Iron, total (Fe) (ppm)</b>	2063.00	21489.6	3530.00	18677.2	986.00	20122.4	11276.00	23639.4
<b>Sulfur, total (S) (%)</b>	0.07%	0.7%	0.19%	1.0%	5.00%	1.0%	0.43%	0.9%
<b>Zinc, total (Zn) (ppm)</b>	6.60	68.7	11.50	60.8	4.20	85.7	32.50	68.1

**Table 23. Compost Soil Reports Part 2.**

	Feb-11		Jun-12		Feb-11		Feb-11		Aug-11	
	Compost		Compost2		Loam		Sand		Tedeschi BSM	
	Compost 16743		MelComp 16778		Loam 16741		Sand 16739		BSMTED16736	
	As is basis	Dry wt. basis	As is basis	Dry wt. basis	As is basis	Dry wt. basis	As is basis	Dry wt. basis	As is basis	Dry wt. basis
pH, SME (pH)	7.00		7.50		7.10		7.20		7.80	
Sol. Salts, 1:2, v/v (EC) (mmhos/cm)	0.77		0.86		0.55		0.01		0.21	
Dry Matter (DM)	44.20%		60.20%		86.80%		99.80%		85.40%	
Nitrogen (N)	0.50%	1.1%	0.60%	1.0%	0.10%	0.1%	0.00%	0.0%	0.10%	0.1%
Organic Matter, LOI-550 (OM)	14.20%		14.20%		2.30%		0.30%		3.20%	
Est. Organic-C (OrganicC)	8.00%	18.1%	9.20%	15.3%	1.30%	1.5%	0.10%	0.1%	1.80%	2.1%
Est. C/N ratio (CNRatio)	15.00		16.60		13.70		68.30		21.50	
Phosphorus, total (P2O5)	0.40%	0.9%	0.21%	0.3%	0.10%	0.1%	0.06%	0.1%	0.10%	0.1%
Potassium, total (K2O)	0.18%	0.4%	0.25%	0.4%	0.14%	0.2%	0.19%	0.2%	0.18%	0.2%
NH4-N, SME (NH4-N) (ppm)	2.20	5.0	3.00	5.0	4.30	5.0	4.40	4.4	4.30	5.0
Aluminum, total (Al) (ppm)	2194.00	4963.8	4146.00	6887.0	6429.00	7406.7	4385.00	4393.8	5660.00	6627.6
Calcium, total (Ca) (%)	0.51%	1.2%	0.62%	1.0%	0.18%	0.2%	0.06%	0.1%	0.19%	0.2%
Magnesium, total (Mg) (%)	0.16%	0.4%	0.21%	0.3%	0.25%	0.3%	0.20%	0.2%	0.17%	0.2%
Sodium, total (Na) (ppm)	254.00	574.7	188.00	312.3	292.00	336.4	61.00	61.1	162.00	189.7
Copper, total (Cu) (ppm)	19.40	43.9	33.80	56.1	15.30	17.6	15.70	15.7	23.60	27.6
Iron, total (Fe) (ppm)	3789.00	8572.4	8207.00	13632.9	11405.00	13139.4	6818.00	6831.7	7355.00	8612.4
Sulfur, total (S) (%)	0.08%	0.2%	0.09%	0.1%	0.02%	0.0%	0.00%	0.0%	0.02%	0.0%
Zinc, total (Zn) (ppm)	47.20	106.8	120.90	200.8	41.20	47.5	18.60	18.6	30.80	36.1

105

**Table 0-24. Sum of Cation Equivalents.**

Material	Al (mg/kg)	Fe (mg/kg)	Ca (mg/kg)	Mg (mg/kg)	Al (meq/kg)	Fe (meq/kg)	Ca (meq/kg)	Mg (meq/kg)	Σcations (meq/kg)
mg/meq	8.994	18.616	20.039	12.153					

<b>WTR0</b>	2000.9	157.1	165.1	28.0	222.5	8.44	8.239	2.304	241.5
<b>WTR2</b>	1588.0	109.0	210.5	26.0	176.6	5.86	10.50	2.139	195.1
<b>WTR3</b>	2050.0	132.0	151.5	19.0	227.9	7.09	7.560	1.563	244.1
<b>WTR4</b>	2330.0	139.0	577.1	31.0	259.1	7.47	28.80	2.551	297.9
<b>Compost1</b>	408.4	246.4	3008.2	621.0	45.40	13.24	150.1	51.10	259.9
<b>Melrose Compost</b>	448.0	276.0	3903.4	527.0	49.81	14.83	194.8	43.36	302.8
<b>Loam</b>	1291.3	258.5	914.2	106.0	143.6	13.88	45.62	8.722	211.8
<b>Sand</b>	619.3	93.8	160.4	40.0	68.86	5.04	8.004	3.291	85.2
<b>Tedeschi BSM</b>	1292.0	135.0	942.6	133.0	143.7	7.25	47.04	10.94	208.9

---

**Table 25. BSM Composition(volumetric)**

	<b>Description</b>	<b>Sand</b>	<b>Wood Chips</b>	<b>Loam</b>	<b>Compost1</b>	<b>Compost2</b>	<b>WTR2</b>	<b>WTR3</b>
BSM 1	No Compost BSM (10% WTR3)	50%	20%	20%				10%
BSM 2	Low P Compost BSM (10% WTR3)	50%	20%	10%		10%		10%
BSM 3	Durham Bio (BSM w/10% WTR2)	50%	20%	10%	10%		10%	
BSM 4	Tree Filter Mix w/ 10% WTR3	80%	0%	0%	10%			10%
BSM 5	Control (No WTR)	50%	20%	10%	20%			
BSM 6	BSM w/5% WTR3	50%	20%	10%	15%			5%
BSM 7	BSM w/10% WTR3	50%	20%	10%	10%			10%
BSM 8	BSM w/15% WTR3	50%	20%	10%	5%			15%

**Table 26. BSM Composition (dry mass basis)**

<b>Name</b>	<b>Description</b>	<b>Sand</b>	<b>Wood Chips</b>	<b>Loam</b>	<b>Compost1</b>	<b>Compost 2</b>	<b>WTR2</b>	<b>WTR3</b>
BSM 1	No Compost BSM (10% WTR3)	79%	3.0%	17%				0.41%
BSM 2	Low P Compost BSM (10% WTR3)	83%	3.2%	9.0%		4.0%		0.43%
BSM 3	Durham Bio (BSM w/10% WTR2)	85%	3.3%	9.2%	1.6%		0.77%	
BSM 4	Tree Filter Mix w/ 10% WTR3	99%			1.2%			0.32%
BSM 5	Control (No WTR)	84%	3.2%	9.1%	3.2%			
BSM 6	BSM w/5% WTR3	85%	3.2%	9.2%	2.4%			0.22%
BSM 7	BSM w/10% WTR3	85%	3.3%	9.2%	1.6%			0.44%
BSM 8	BSM w/15% WTR3	86%	3.3%	9.3%	0.8%			0.67%

## **APPENDIX B**

### **Batch Equilibrium Studies Data**

**Table 27. Kinetics Study 1 4/6-4/8/2011.**

<b>Starting Conditions:</b>				<b>OP (mg/L)</b>	<b>NO3 (mg/L)</b>
<b>STORMWATER</b>	<b>spiked SW</b>			0.9	5.2
<b>Adsorbent:</b>	<b>WTR1</b>				
<b>Sample ID</b>	<b>Description</b>	<b>Mass of material (mg)</b>	<b>Length of Time (hrs)</b>	<b>OP Concentration (mg/L)</b>	<b>NO3 Concentration (mg/L)</b>
KW01H29	WTR1	100.5	1	0.49	5.2
KW02H21	WTR1	101.1	2	0.35	5.2
KW04H25	WTR1	99.7	4	0.25	5.3
KW06H13	WTR1	100.2	6	0.15	5.3
KW08H17	WTR1	100.9	8	0.31	5.3
KW18H01	WTR1	80.8	18	0.02	5.2
KW24H09	WTR1	100.1	24	0.05	5.2
KW24H09D	WTR1	100.3	24	0.04	5.2
KW48H05	WTR1	69.5	48	<0.01	5.2
<b>EQUIP BLANK</b>	equip blank			<0.01	<0.1
<b>TRIP BLANK</b>	trip blank			<0.01	<0.1
<b>TRIP BLANK</b>	trip blank 2			<0.01	<0.1
<b>Adsorbent:</b>	<b>Compost1</b>				
<b>Sample ID</b>	<b>Description</b>	<b>Mass of material (mg)</b>	<b>Length of Time (hrs)</b>	<b>OP Concentration (mg/L)</b>	<b>NO3 Concentration (mg/L)</b>
KC01H30	Compost1	98.9	1	3.2	5.3
KC02H22	Compost1	100.3	2	2.2	5.4
KC04H26	Compost1	100.6	4	2.5	5.3
KC06H14	Compost1	101.2	6	2.4	5.4
KC08H18	Compost1	100.6	8	1.4	5.4
KC18H02	Compost1	83.5	18	2.5	5.2
KC24H10	Compost1	100.7	24	1.7	5.2
KC48H06	Compost1	36.4	48	3.3	5.2

Continued from previous page.

<b>Adsorbent: Loam</b>					
<b>Sample ID</b>	<b>Description</b>	<b>Mass of material (mg)</b>	<b>Length of Time (hrs)</b>	<b>OP Concentration (mg/L)</b>	<b>NO3 Concentration (mg/L)</b>
KL01H31	Loam	100.3	1	0.8	5.4
KL01H31D	Loam	99.1	1	0.77	5.3
KL02H23	Loam	99.3	2	0.76	5.4
KL04H27	Loam	100.7	4	0.73	5.4
KL06H15	Loam	100.2	6	0.67	5.4
KL08H19	Loam	100.8	8	0.74	5.4
KL18H03	Loam	56.6	18	0.77	5.4
KL24H11	Loam	99.6	24	0.61	5.3
KL48H07	Loam	91.1	48	0.77	5.3
<b>Adsorbent: Sand</b>					
KS01H32	Sand	100.2	1	0.8	5.2
KS02H24	Sand	100.6	2	0.82	4.2
KS04H28	Sand	100.6	4	0.89	5.2
KS04H28D	Sand	100.2	4	0.76	5.2
KS06H16	Sand	100.3	6	0.72	5.2
KS08H20	Sand	100.2	8	0.76	5.3
KS18H04	Sand	99.6	18	0.7	5.2
KS24H12	Sand	98.9	24	0.74	5.1
KS48H08	Sand	99.3	48	0.66	5.2



**Table 28. Kinetics Study 9/20-9/23/2011 .**

<b>Starting Conditions:</b>				<b>OP (mg/L)</b>	<b>NO3 (mg/L)</b>
<b>STORMWATER</b>	<b>INF9-21</b>			1.1	4.9
<b>Adsorbent:</b>	<b>WTR2(2mm)</b>				
<b>Sample ID</b>	<b>Description</b>	<b>Mass of material (mg)</b>	<b>Length of Time (hrs)</b>	<b>OP Concentration (mg/L)</b>	<b>NO3 Concentration (mg/L)</b>
KWF60-1	WTR2(2mm)	100.4	60	0.68	6.6
KWF60-2	WTR2(2mm)	100.7	60	0.84	5
KWF60-2-45	WTR2(2mm)			0.77	5
KWF60-3	WTR2(2mm)	102.2	60	0.68	5
KWF60-3-45	WTR2(2mm)			0.66	5
KWF60-4	WTR2(2mm)	101.5	60	0.7	4.9
KWF60-5	WTR2(2mm)	100.9	60	0.73	5
KWF02	WTR2(2mm)	100.1	2	0.96	5
KWF01	WTR2(2mm)	100.5	1	0.99	5
KWF12-1	WTR2(2mm)	99.5	12	0.93	5
KWF12-2	WTR2(2mm)	100.6	12	0.93	5
KWF48	WTR2(2mm)	100.8	48	0.77	5
KWF08	WTR2(2mm)	100.1	8	0.95	5
KWF06	WTR2(2mm)	100.1	4	0.97	5
KWF04	WTR2(2mm)	99.8	6	0.95	5
KWF18	WTR2(2mm)	100.2	18	0.86	4.9
KWF36	WTR2(2mm)	100.8	36	0.93	5
KWF24	WTR2(2mm)	100.2	24	0.87	4.9

Table 29. Kinetics Study 1/11-1/20/12 .

Starting Conditions:				OP (mg/L)	NO3 (mg/L)
INF1-11				1.1	5.0
INF1-16				0.93	5.4
<b>Adsorbent:</b>	<b>WTR2</b>				
Sample ID	Description	Mass of material (mg)	Length of Time (hrs)	OP Concentration (mg/L)	NO3 Concentration (mg/L)
KJW2-02	WTR2	99.8	2	0.81	4.9
KJW2-04	WTR2	100.2	4	0.76	4.9
KJW2-08	WTR2	99.4	8	0.7	5
KJW2-08D	WTR2	100.1	8	0.65	5
KJW2-18	WTR2	99.5	18	0.6	4.9
KJW2-24	WTR2	99.1	24	0.53	4.8
KJW2-36	WTR2	100.1	42	0.47	5
KJW2-48	WTR2	100	48	0.45	4.9
KJW2-72	WTR2	100	72	0.42	4.9
KJW2-96	WTR2	100.2	92	0.34	5
EQUIP 1-11				0.002	<0.1
TRIP BLANK				<0.001	<0.1
<b>Adsorbent:</b>	<b>WTR3</b>				
KJW3-02	WTR3	99.9	2	0.48	4.9
KJW3-04	WTR3	99.8	4	0.35	5
KJW3-08	WTR3	99.3	8	0.21	4.9
KJW3-18	WTR3	99.4	18	0.097	4.9
KJW3-24	WTR3	99.8	24	0.034	4.9
KJW3-36	WTR3	100.3	42	0.008	4.8
KJW3-36D	WTR3	100.5	42	0.008	4.9
KJW3-48	WTR3	100.3	48	0.015	4.9
KJW3-72	WTR3	100.3	72	0.015	5.1
KJW3-96	WTR3	100.8	92	0.01	4.9

**Table 30. Component Isotherm Studies(Grayed out rows indicate data points removed from analyses after QC) .**

Starting Conditions:										OP (mg/L)
STORMWATER	spiked SW									1.2
Adsorbent: WTR1										
Sample ID	Description	Mass of Adsorbent (mg)	C = OP Conc (mg/L)	% Removed	M = g Adsorbent/L stormwater	q = (Co-C)/M	Lang X = C (mg P/L)	Lang Y = C/q	Freund X = log C	Freund Y = log q
IW010	WTR1	10.2	0.86	28.3%	0.10	3.33	0.86	0.26	-0.07	0.52
IW040	WTR1	39.5	0.38	68.3%	0.40	2.08	0.38	0.18	-0.42	0.32
IW040D	WTR1	39.6	0.35	70.8%	0.40	2.15	0.35	0.16	-0.46	0.33
IW070	WTR1	70.2	0.06	95.0%	0.70	1.62	0.06	0.04	-1.22	0.21
IW100	WTR1	99.9	0.05	95.8%	1.00	1.15	0.05	0.04	-1.30	0.06
IW130	WTR1	128.7	0.005	99.6%	1.29	0.93	0.005	0.005	-2.30	-0.03
IW160	WTR1	160.5	0.005	99.6%	1.61	0.74	0.005	0.007	-2.30	-0.13
Starting Conditions:										OP (mg/L)
STORMWATER	spiked SW									0.99
Adsorbent: WTR2										
Sample ID	Description	Mass of Adsorbent (mg)	C = OP Conc (mg/L)	% Removed	M = g Adsorbent/L stormwater	q = (Co-C)/M	Lang X = C (mg P/L)	Lang Y = C/q	Freund X = log C	Freund Y = log q
IJW2-010	WTR2	9.8	0.98	1.0%	0.10	0.102	0.98	9.60	-0.009	-0.991
IJW2-040	WTR2	39.5	0.81	18.2%	0.40	0.456	0.81	1.78	-0.092	-0.341
IJW2-040D	WTR2	40.1	0.82	17.2%	0.40	0.424	0.82	1.93	-0.086	-0.373
IJW2-070	WTR2	70.2	0.67	32.3%	0.70	0.456	0.67	1.47	-0.174	-0.341
IJW2-100	WTR2	99.4	0.51	48.5%	0.99	0.483	0.51	1.06	-0.292	-0.316
IJW2-130	WTR2	129.7	0.38	61.6%	1.30	0.470	0.38	0.81	-0.420	-0.328
IJW2-160	WTR2	160	0.29	70.7%	1.60	0.438	0.29	0.66	-0.538	-0.359

Continued from previous page.

Starting Conditions:										OP (mg/L)
STORMWATER	spiked SW									0.99
Adsorbent: WTR3										
Sample ID	Description	Mass of Adsorbent (mg)	C = OP Conc (mg/L)	% Removed	M = g Adsorbent/L stormwater	q = (Co-C)/M	Lang X = C (mg P/L)	Lang Y = C/q	Freund X = log C	Freund Y = log q
IJW3-010	WTR3	10.2	0.94	5.1%	0.10	0.49	0.94	1.92	-0.03	-0.310
IJW3-040	WTR3	38.4	0.58	41.4%	0.38	1.07	0.58	0.54	-0.24	0.0285
IJW3-070	WTR3	70.5	0.19	80.8%	0.71	1.13	0.19	0.17	-0.72	0.0549
IJW3-100	WTR3	99.6	0.013	98.7%	1.00	0.98	0.013	0.01	-1.89	-0.0084
IJW3-130	WTR3	130.1	0.003	99.7%	1.30	0.76	0.003	0.004	-2.52	-0.120
IJW3-160	WTR3	159.8	0.003	99.7%	1.60	0.62	0.003	0.005	-2.52	-0.209
Adsorbent: WTR4										
Sample ID	Description	Mass of Adsorbent (mg)	C = OP Conc (mg/L)	% Removed	M = g Adsorbent/L stormwater	q = (Co-C)/M	Lang X = C (mg P/L)	Lang Y = C/q	Freund X = log C	Freund Y = log q
IWTR4-010	WTR4	10.1	0.86	13.1%	0.10	1.29	0.86	0.669	-0.0656	0.109
IWTR4-040	WTR4	39.9	0.62	37.4%	0.40	0.927	0.62	0.669	-0.208	-0.0328
IWTR4-070	WTR4	70.2	0.41	58.6%	0.70	0.825	0.41	0.497	-0.387	-0.0833
IWTR4-100	WTR4	100.1	0.26	73.7%	1.00	0.730	0.26	0.356	-0.585	-0.137
IWTR4-130	WTR4	130.23	0.13	86.9%	1.30	0.660	0.13	0.197	-0.886	-0.180
IWTR4-160	WTR4	159.7	0.078	92.1%	1.60	0.571	0.078	0.137	-1.108	-0.243

Continued from previous page.

Starting Conditions:										OP (mg/L)
STORMWATER	spiked SW									1.2
Adsorbent: Loam										
Sample ID	Description	Mass of Adsorbent (mg)	C = OP Conc (mg/L)	% Removed	M = g Adsorbent/L stormwater	q = (Co-C)/M	Lang X = C (mg P/L)	Lang Y = C/q	Freund X = log C	Freund Y = log q
IL010	Loam	10.3	1.1	8.3%	0.10	0.97	1.1	1.13	0.04	-0.0128
IL040	Loam	40.2	0.98	18.3%	0.40	0.55	0.98	1.79	-0.009	-0.262
IL070	Loam	69.4	0.86	28.3%	0.69	0.49	0.86	1.76	-0.066	-0.310
IL100	Loam	100.8	0.77	35.8%	1.01	0.43	0.77	1.81	-0.114	-0.370
IL130	Loam	130.3	0.64	46.7%	1.30	0.43	0.64	1.49	-0.194	-0.367
IL130D	Loam	129.7	0.64	46.7%	1.30	0.43	0.64	1.48	-0.194	-0.365
IL160	Loam	160.4	0.56	53.3%	1.60	0.40	0.56	1.40	-0.194	-0.399
Starting Conditions:										OP (mg/L)
STORMWATER	spiked SW									1.2
Adsorbent: Sand										
Sample ID	Description	Mass of Adsorbent (mg)	C = OP Conc (mg/L)	% Removed	M = g Adsorbent/L stormwater	q = (Co-C)/M	Lang X = C (mg P/L)	Lang Y = C/q	Freund X = log C	Freund Y = log q
IS010	Sand	9.8	1.1	8.3%	0.10	1.02	1.1	1.08	0.041	0.0088
IS040	Sand	40	1	16.7%	0.40	0.50	1	2.00	0.000	-0.301
IS070	Sand	70.3	0.94	21.7%	0.70	0.37	0.94	2.54	-0.027	-0.432
IS100	Sand	100.2	0.89	25.8%	1.00	0.31	0.89	2.88	-0.051	-0.510
IS130	Sand	130.4	0.87	27.5%	1.30	0.25	0.87	3.44	-0.060	-0.597
IS160	Sand	159.5	0.8	33.3%	1.60	0.25	0.8	3.19	-0.097	-0.601

Continued from previous page.

Starting Conditions:										OP (mg/L)
STORMWATER	spiked SW									1.2
Adsorbent: Compost1										
Sample ID	Description	Mass of Adsorbent (mg)	C = OP Conc (mg/L)	% Removed	M = g Adsorbent/L stormwater	q = (Co-C)/M	Lang X = C (mg P/L)	Lang Y = C/q	Freund X = log C	Freund Y = log q
IC010	Compost1	10.7	1.4	-16.7%	0.11	-1.87	1.4	-0.75	0.15	N/A
IC040	Compost1	40.5	2.1	-75.0%	0.41	-2.22	2.1	-0.95	0.32	N/A
IC070	Compost1	70	2.6	-116.7%	0.70	-2.00	2.6	-1.30	0.41	N/A
IC100	Compost1	100.5	3.2	-166.7%	1.01	-1.99	3.2	-1.61	0.51	N/A
IC130	Compost1	129.8	3.6	-200.0%	1.30	-1.85	3.6	-1.95	0.56	N/A
IC160	Compost1	159.1	4.1	-241.7%	1.59	-1.82	4.1	-2.25	0.61	N/A

**Table 31. Bioretention Soil Mix (BSM) Isotherm Studies(Grayed out rows indicate data points removed from analyses after QC) .**

Starting Conditions:										OP (mg/L)
STORMWATER		INF								0.99
Adsorbent: BSM1										
Sample ID	Description	Mass of Adsorbent (mg)	C = OP Conc (mg/L)	% Removed	M = g Adsorbent/L stormwater	q = (Co-C)/M	Lang X = C (mg P/L)	Lang Y = C/q	Freund X = log C	Freund Y = log q
IBSM1-010	BSM1	9.5	0.91	8.1%	0.10	0.841	0.91	1.082	-0.041	-0.075
IBSM1-040	BSM1	40.1	0.73	26.3%	0.40	0.650	0.73	1.124	-0.137	-0.187
IBSM1-040D	BSM1	40	0.75	24.2%	0.40	0.599	0.75	1.251	-0.125	-0.222
IBSM1-070	BSM1	70.2	0.61	38.4%	0.70	0.542	0.61	1.126	-0.215	-0.266
IBSM1-100	BSM1	100.3	0.48	51.5%	1.00	0.509	0.48	0.943	-0.319	-0.293
IBSM1-130	BSM1	129.9	0.38	61.6%	1.30	0.470	0.38	0.809	-0.420	-0.328
IBSM1-160	BSM1	159.5	0.3	69.7%	1.59	0.433	0.3	0.693	-0.523	-0.363

Continued from previous page.

<b>Adsorbent: BSM2</b>										
<b>Sample ID</b>	<b>Description</b>	<b>Mass of Adsorbent (mg)</b>	<b>C = OP Conc (mg/L)</b>	<b>% Removed</b>	<b>M = g Adsorbent/L stormwater</b>	<b>q = (Co-C)/M</b>	<b>Lang X = C (mg P/L)</b>	<b>Lang Y = C/q</b>	<b>Freund X = log C</b>	<b>Freund Y = log q</b>
<b>IBSM2-010</b>	BSM2	10	0.9	9.1%	0.10	0.899	0.9	1.001	-0.046	-0.046
<b>IBSM2-040</b>	BSM2	40.4	0.76	23.2%	0.40	0.569	0.76	1.335	-0.119	-0.245
<b>IBSM2-070</b>	BSM2	69.7	0.64	35.4%	0.70	0.502	0.64	1.276	-0.194	-0.300
<b>IBSM2-100</b>	BSM2	100.1	0.52	47.5%	1.00	0.470	0.52	1.107	-0.284	-0.328
<b>IBSM2-130</b>	BSM2	130	0.43	56.6%	1.30	0.431	0.43	0.998	-0.367	-0.366
<b>IBSM2-160</b>	BSM2	160.1	0.38	61.6%	1.60	0.381	0.38	0.997	-0.420	-0.419
<b>Adsorbent: BSM3</b>										
<b>IBSM3-010</b>	BSM3	10.4	0.88	11.1%	0.10	1.057	0.88	0.833	-0.056	0.024
<b>IBSM3-040</b>	BSM3	40.1	0.72	27.3%	0.40	0.674	0.72	1.068	-0.143	-0.171
<b>IBSM3-070</b>	BSM3	70	0.59	40.4%	0.70	0.571	0.59	1.033	-0.229	-0.243
<b>IBSM3-100</b>	BSM3	100	0.47	52.5%	1.00	0.520	0.47	0.904	-0.328	-0.284
<b>IBSM3-100D</b>	BSM3	100.1	0.48	51.5%	1.00	0.510	0.48	0.941	-0.319	-0.292
<b>IBSM3-130</b>	BSM3	129.6	0.39	60.6%	1.29	0.463	0.39	0.842	-0.409	-0.334
<b>IBSM3-160</b>	BSM3	160.2	0.28	71.7%	1.60	0.444	0.28	0.631	-0.553	-0.353
<b>Adsorbent: BSM4</b>										
<b>IBSM4-010</b>	BSM4	10	0.93	6.1%	0.10	0.601	0.93	1.548	-0.032	-0.221
<b>IBSM4-040</b>	BSM4	40.2	0.84	15.2%	0.40	0.374	0.84	2.249	-0.076	-0.428
<b>IBSM4-070</b>	BSM4	69.7	0.75	24.2%	0.70	0.344	0.75	2.178	-0.125	-0.463
<b>IBSM4-070D</b>	BSM4	69.6	0.76	23.2%	0.70	0.331	0.76	2.298	-0.119	-0.480
<b>IBSM4-100</b>	BSM4	100	0.68	31.3%	1.00	0.310	0.68	2.196	-0.167	-0.509
<b>IBSM4-130</b>	BSM4	129.8	0.58	41.4%	1.30	0.316	0.58	1.838	-0.237	-0.501
<b>IBSM4-160</b>	BSM4	160	0.5	49.5%	1.60	0.306	0.5	1.633	-0.301	-0.514



Continued from previous page.

Adsorbent: BSM5										
Sample ID	Description	Mass of Adsorbent (mg)	C = OP Conc (mg/L)	% Removed	M = g Adsorbent/L stormwater	q = (Co-C)/M	Lang X = C (mg P/L)	Lang Y = C/q	Freund X = log C	Freund Y = log q
IBSM5-010	BSM5	9.7	1	-1.0%	0.10	-0.103	1	-9.710	N/A	N/A
IBSM5-040	BSM5	39.7	1	-1.0%	0.40	-0.025	1	-39.700	N/A	N/A
IBSM5-070	BSM5	69.3	1	-1.0%	0.69	-0.014	1	-69.300	N/A	N/A
IBSM5-070D	BSM5	70.5	1	-1.0%	0.70	-0.014	1	-70.430	N/A	N/A
IBSM5-100	BSM5	100	1	-1.0%	1.00	-0.010	1	-99.900	N/A	N/A
IBSM5-130	BSM5	130	1	-1.0%	1.30	-0.008	1	-129.870	N/A	N/A
IBSM5-160	BSM5	160.2	1	-1.0%	1.60	-0.006	1	-160.200	N/A	N/A
Adsorbent: BSM6										
IBSM6-010	BSM6	9.9	0.93	6.1%	0.10	0.605	0.93	1.538	-0.032	-0.218
IBSM6-040	BSM6	40.2	0.84	15.2%	0.40	0.373	0.84	2.253	-0.076	-0.429
IBSM6-070	BSM6	69.9	0.74	25.3%	0.70	0.357	0.74	2.071	-0.131	-0.447
IBSM6-100	BSM6	100.4	0.67	32.3%	1.01	0.318	0.67	2.104	-0.174	-0.497
IBSM6-130	BSM6	130.3	0.59	40.4%	1.30	0.307	0.59	1.924	-0.229	-0.513
IBSM6-160	BSM6	159.9	0.53	46.5%	1.60	0.288	0.53	1.842	-0.276	-0.541
Adsorbent: BSM7										
IBSM7-010	BSM7	10	0.87	12.1%	0.10	1.200	0.87	0.725	-0.060	0.079
IBSM7-040	BSM7	40.1	0.71	28.3%	0.40	0.697	0.71	1.019	-0.149	-0.157
IBSM7-070	BSM7	69.7	0.57	42.4%	0.70	0.601	0.57	0.948	-0.244	-0.221
IBSM7-100	BSM7	99.9	0.44	55.6%	1.00	0.551	0.44	0.799	-0.357	-0.259
IBSM7-100D	BSM7	100.1	0.45	54.5%	1.00	0.539	0.45	0.835	-0.347	-0.268
IBSM7-130	BSM7	129.5	0.37	62.6%	1.29	0.479	0.37	0.772	-0.432	-0.319
IBSM7-160	BSM7	159.5	0.3	69.7%	1.59	0.433	0.3	0.693	-0.523	-0.363

Continued from previous page.

Adsorbent: BSM8										
Sample ID	Description	Mass of Adsorbent (mg)	C = OP Conc (mg/L)	% Removed	M = g Adsorbent/L stormwater	q = (Co-C)/M	Lang X = C (mg P/L)	Lang Y = C/q	Freund X = log C	Freund Y = log q
IBSM8-010	BSM8	9.9	0.87	12.1%	0.10	1.211	0.87	0.718	-0.060	0.083
IBSM8-040	BSM8	39.7	0.64	35.4%	0.40	0.882	0.64	0.725	-0.194	-0.054
IBSM8-070	BSM8	70.1	0.45	54.5%	0.70	0.770	0.45	0.585	-0.347	-0.114
IBSM8-100	BSM8	100.2	0.3	69.7%	1.00	0.687	0.3	0.437	-0.523	-0.163
IBSM8-130	BSM8	130.4	0.23	76.8%	1.30	0.583	0.23	0.395	-0.638	-0.234
IBSM8-160	BSM8	159.5	0.16	83.8%	1.60	0.520	0.16	0.307	-0.796	-0.284

## **APPENDIX C**

**Column Studies Hydraulics Data**

**Column Studies Water Quality Data**

**Table 32. Infiltration Rates (in/hr) from phase 1 column studies.**

	<b>TF.05</b>	<b>BSM.05</b>	<b>BSM.10</b>	<b>BSM.15</b>
Event 1	13	30	19	15
Event 2	12	19	17	14
Event 3	13	21	19	16
Event 4	11	20	16	16
Event 5	11	20	15	14

**Table 33. Infiltration Rates (in/hr) from phase 2 column studies.**

	<b>BSM.05-1</b>	<b>BSM.05-2</b>	<b>BSM.10-1</b>	<b>BSM.10-2</b>	<b>BSM.15-1</b>	<b>BSM.15-2</b>	<b>TF.10-1</b>	<b>TF.10-2</b>
Event 1	13	5	5	5	5	5	5	5
Event 2	135	132	136	137	186	187	87	87
Event 3	72	79	165	94	214	228	101	101
Event 4	101	141	183	88	174	157	106	106
Event 5	75	145	141	90	155	191	N/A	N/A
Event 6	68	121	134	56	91	185	92	92
Event 7	78	90	105	66	147	171	101	101

**Table 34. Infiltration Rates (in/hr) from phase 3 column studies.**

		<b>BSM1</b>	<b>BSM2</b>	<b>BSM3</b>	<b>BSM3D</b>	<b>BSM4</b>	<b>BSM5</b>	<b>BSM6</b>	<b>BSM7</b>	<b>BSM8</b>
RO Run 1	Total	346	490	490	490	158	452	534	489	195
RO Run 2	Total	245	196	280	267	116	255	245	308	82
	Interval Test*	N/A	218	360	N/A	107	280	341	252	82
Yr 1	Total	242	196	158	222	104	226	214	195	53
	Interval Test*	269	205	167	237	105	266	237	221	52
Yr 2	Total	171	178	113	186	103	178	165	107	43
	Interval Test*	179	191	119	199	107	195	182	113	45
Yr 4-8	Total	195	204	35	200	118	249	161	187	52
	Interval Test*	205	212	37	212	120	273	173	196	50
Yr 10-14	Total	170	172	22	161	103	196	128	106	47
	Interval Test*	177	178	21	162	109	207	134	109	44
Yr 16-20	Total	150	175	14	125	102	187	70	97	47
	Interval Test*	157	182	13	148	107	199	71	101	47
Permeameter		605	351	424	424	235	293	577	270	283

\* Interval Tests were conducted at constant 6 inch ponding on columns, in which times were noted for the collection of a certain volume of effluent.

**Table 35. Empty Bed Contact Times (minutes) from phase 1 column studies.**

	<b>BSM.05</b>	<b>BSM.10</b>	<b>BSM.15</b>	<b>TF</b>
$V_{BSM}$ (mL)=	811	811	811	811
Event 1	41	64	83	92
Event 2	65	71	87	104
Event 3	60	64	76	92
Event 4	61	77	78	112
Event 5	61	83	87	108
<b>MEDIAN</b>	<b>61</b>	<b>71</b>	<b>83</b>	<b>104</b>

**Table 36. Empty Bed Contact Times (minutes) from phase 2column studies.**

	<b>BSM.05-1</b>	<b>BSM.05-2</b>	<b>BSM.10-1</b>	<b>BSM.10-2</b>	<b>BSM.15-1</b>	<b>BSM.15-2</b>	<b>TF.10-1</b>	<b>TF.10-2</b>
V <sub>BSM</sub> (mL)=	695	695	695	695	695	695	695	695
Event 1	113.73	310.33	284.72	316.71	281.92	282.07	289.67	289.67
Event 2	10.69	10.94	10.58	10.48	7.76	7.71	16.53	16.53
Event 3	20.12	18.30	8.75	15.34	6.73	6.31	14.19	14.19
Event 4	14.32	10.23	7.85	16.41	8.27	9.17	13.61	13.61
Event 5	19.17	9.91	10.22	16.01	9.32	7.52	N/A	N/A
Event 6	21.30	11.93	10.73	25.74	15.78	7.80	15.60	15.60
Event 7	18.49	16.02	13.74	21.78	9.79	8.41	14.24	14.24
<b>MEDIAN</b>	<b>19</b>	<b>12</b>	<b>11</b>	<b>16</b>	<b>9</b>	<b>8</b>	<b>15</b>	<b>15</b>

**Table 37. Empty Bed Contact Times (minutes) from phase 3column studies, as determined from total run times and total effluent volumes for each event.**

	<b>BSM1</b>	<b>BSM2</b>	<b>BSM3</b>	<b>BSM3D</b>	<b>BSM4</b>	<b>BSM5</b>	<b>BSM6</b>	<b>BSM7</b>	<b>BSM8</b>
V <sub>BSM</sub> (mL)=	695	695	695	695	695	695	695	695	695
Yr 1	6	7	9	7	14	6	7	7	27
Yr 2	8	8	13	8	14	8	9	13	33
Yr 4-8	7	7	41	7	12	6	9	8	28
Yr 10-14	8	8	65	9	14	7	11	14	31
Yr 16-20	10	8	107	12	14	8	21	15	30
<b>MEDIAN</b>	<b>8</b>	<b>8</b>	<b>41</b>	<b>8</b>	<b>14</b>	<b>7</b>	<b>9</b>	<b>13</b>	<b>30</b>

**Table 38. Calculations of Annual OP Load.**

Parameter	Value	Units
Local Avg Annual Rainfall	46	in
Expected Avg OP Concentration	0.02	mg/L
Conversion factor for cu. in.	0.016387	in <sup>3</sup> /L
Conversion factor for cu. ft.	0.0353147	ft <sup>3</sup> /L
Drainage Area to Filter Area	20	-
Annual OP Load	43.4	mg/ft <sup>2</sup>

**Table 39. Calculations of OP Loads**

	Phase 1	Phase 2	Phase 3 (short term)	Phase 3 (long term)	Phase 3 Totals
# Events	5	7	2	3	5
Median Influent Volume per event (L)	5.11	3.700	2.83	3.431	
Total Volume of Influent (L)	25.5	25.880	50.93	92.6	143.6
Column X-sec Area (sq in)	2.061	1.767	1.767	1.767	
Drainage to Filter Ratio	20	20	20	20	
Simulated rainfall per event (in)	7.6	6.4	4.9	5.9	
<b>Total simulated rainfall (in)</b>	37.8	44.7	9.8	17.8	27.5
Median Influent OP Concentration (mg/L)	1.1	0.93	0.19	0.98	
OP load per event(mg)	5.620	3.441	0.538	3.363	
<b>Total OP load (mg)</b>	28.10	24.07	1.08	10.09	11.16
Annual Hydraulic Load (L)	31.1	26.6	26.6	26.6	
Annual OP Load (mg)	0.62	0.53	0.53	0.53	1.07
OP load per event (years)	9.0	6.5	1.0	6.3	
<b>Total OP load (years)</b>	45.2	45.2	2.0	18.9	21.0

**Table 40. Phase 1 Column Study OP Concentration Data.**

Event	Influent OP Conc. (mg/L)	Annual OP Loads (years)	Q (L/ sample)	Empty Bed Volumes	Effluent OP Concentrations (mg/L)				
					BSM.05	BSM.10	BSM.15	TF.05	RG
1	1.30	10.7	5.11	6.30	0.020	0.005	0.005	0.005	0.05
2	1.10	19.7	5.11	12.60	0.005	0.005	0.005	0.005	
3	1.1	28.8	5.11	18.90	0.005	0.005	0.005	0.005	
4	1.1	37.8	5.11	25.20	0.005	0.005	0.005	0.005	
5	0.92	45.4	5.11	31.50	0.020	0.005	0.005	0.005	
Median	1.1				0.005	0.005	0.005	0.005	0.050

**Table 41. Phase 1 Column Study Removal Efficiencies.**

<b>Event</b>	<b>Influent OP Conc. (mg/L)</b>	<b>Annual OP Loads (years)</b>	<b>Q (L/ sample)</b>	<b>Empty Bed Volumes</b>	<b>OP Removal Efficiencies</b>				
					<b>BSM.05</b>	<b>BSM.10</b>	<b>BSM.15</b>	<b>TF.05</b>	<b>RG</b>
1	1.30	10.7	5.11	6.30	98.18%	99.55%	99.55%	99.55%	95.5%
2	1.10	19.7	5.11	12.60	99.55%	99.55%	99.55%	99.55%	
3	1.1	28.8	5.11	18.90	99.55%	99.55%	99.55%	99.55%	
4	1.1	37.8	5.11	25.20	99.55%	99.55%	99.55%	99.55%	
5	0.92	45.4	5.11	31.50	98.18%	99.55%	99.55%	99.55%	
Median	1.1				99.55%	99.55%	99.55%	99.55%	



**Table 42. Phase 2 Column Study OP Concentration Data.**

Event	Set 1	Set 2	Annual OP Loads (years)	Q (L/ sample)	Empty Bed Volumes	Effluent OP Concentrations (mg/L)							
	Influent OP Conc. (mg/L)					BSM.05 -1	BSM.05 -2	BSM.10 -1	BSM.10 -2	BSM.15 -1	BSM.15 -2	TF.10 -1	TF.10 -2
1	0.94	0.93	6.5	3.7	5.32	0.083	0.120	0.020	0.031	0.005	0.006	0.005	0.011
2	0.91	0.92	12.9	3.7	10.65	0.140	0.260	0.028	0.050	0.037	0.037	0.007	0.010
3	0.91	0.89	19.4	3.7	15.97	0.180	0.260	0.068	0.059	0.056	0.061	0.008	0.011
4	0.88	0.93	25.8	3.7	21.29	0.273	0.373	0.103	0.075	0.052	0.063	0.006	0.011
5			32.3	3.7	26.62	0.290	0.430	0.090	0.085	0.055	0.073	0.007	0.011
6	0.93	1.00	38.7	3.7	31.94	0.340	0.430	0.110	0.086	0.036	0.120	0.006	0.014
7	1.10	0.96	45.2	3.7	37.26	0.490	0.580	0.140	0.150	0.130	0.110	0.024	0.024
Median	0.93					0.273	0.373	0.090	0.075	0.052	0.063	0.007	0.011

**Table 43. Phase 2 Column Study OP Removal Efficiencies.**

Event	Set 1	Set 2	Annual OP Loads (years)	Q (L/ sample)	Empty Bed Volumes	OP Removal Efficiencies							
	Influent OP Conc. (mg/L)					BSM.05 -1	BSM.05 -2	BSM.10 -1	BSM.10 -2	BSM.15 -1	BSM.15 -2	TF.10 -1	TF.10 -2
1	0.94	0.93	6.4575807	3.7	5.32	91%	87%	98%	97%	99%	99%	99%	99%
2	0.91	0.92	12.915161	3.7	10.65	85%	72%	97%	95%	96%	96%	99%	99%
3	0.91	0.89	19.372742	3.7	15.97	81%	72%	93%	94%	94%	93%	99%	99%
4	0.88	0.93	25.830323	3.7	21.29	71%	60%	89%	92%	94%	93%	99%	99%
5			32.287904	3.7	26.62	69%	54%	90%	91%	94%	92%	99%	99%
6	0.93	1.00	38.745484	3.7	31.94	63%	54%	88%	91%	96%	87%	99%	98%
7	1.10	0.96	45.203065	3.7	37.26	47%	38%	85%	84%	86%	88%	97%	97%
Median	0.93					71%	60%	90%	92%	94%	93%	99%	99%

**Table 44. Phase 3 Column Study OP Concentration Data.**

Simulated Event Date	Sample #	Influent OP Conc. (mg/L)	Annual OP Loads (years)	Q (L/sample)	Empty Bed Volumes	Effluent OP Concentrations (mg/L)								
						BSM 1	BSM 2	BSM 3	BSM 3D	BSM 4	BSM 5	BSM 6	BSM 7	BSM 8
7/25/2012	1	0.20	0.27	0.75	1.08	0.005	0.009	0.006	0.006	0.007	0.47	0.036	0.011	0.005
	2	0.19	0.53	0.75	2.16	0.006	0.013	0.006	0.006	0.007	0.44	0.042	0.013	<b>0.008</b>
	3	0.19	0.80	0.75	3.24	0.009	0.018	0.006	0.006	0.007	0.42	0.051	0.017	0.010
	4		1.02	0.60	4.10	0.009	0.020	0.006	0.006	0.007	0.42	0.056	0.026	0.011
7/26/2012	5	0.19	1.28	0.75	5.18	0.006	0.012	0.008	0.008	0.008	0.51	0.042	0.012	0.007
	6		1.55	0.75	6.26	0.006	0.016	0.007	0.007	0.008	0.47	0.049	0.012	0.009
	7		1.82	0.75	7.34	0.007	0.020	0.008	0.007	0.008	0.45	0.055	0.013	0.011
	8		2.03	0.60	8.20	0.007	0.021	0.008	0.007	0.008	0.44	0.060	0.014	0.012
7/31/2012	9	0.98	4.06	1.10	9.78	0.028	0.130	0.008	0.012	0.008	0.78	0.130	0.086	0.079
	10		6.08	1.10	11.37	0.073	0.240	0.008	0.032	0.021	0.90	0.270	0.180	0.150
	11		8.29	1.20	13.09	0.110	0.270	0.009	0.054	0.050	0.93	0.340	0.230	0.200
8/1/2012	12	0.94	10.31	1.10	14.68	0.043	0.160	0.012	0.017	0.018	0.92	0.180	0.069	0.150
	13		12.33	1.10	16.26	0.098	0.260	0.240	0.760	0.980	1.00	0.320	0.140	0.240
	14		14.54	1.20	17.99	0.140	0.310	0.260	0.063	0.110	1.00	0.400	0.190	0.290
8/2/2012	15	0.98	16.56	1.10	19.57	0.063	0.220	0.032	0.038	0.050	1.00	0.180	0.110	0.200
	16		18.59	1.10	21.15	0.130	0.340	0.031	0.080	0.110	1.10	0.310	0.180	0.310
	17		20.79	1.20	22.88	0.170	0.380	0.037	0.082	0.180	1.10	0.410	0.220	0.370
Short-Term Median		0.19				0.007	0.017	0.007	0.007	0.008	0.445	0.050	0.013	0.010
Long-Term Median		0.98				0.098	0.260	0.031	0.054	0.050	1.000	0.310	0.180	0.200

**Table 45. Phase 3 Column Study OP Removal Efficiencies.**

Simulated Event Date	Sample #	Influent OP Conc. (mg/L)	Annual OP Loads (years)	Q (L/sample)	Empty Bed Volumes	OP Removal Efficiencies								
						BSM 1	BSM 2	BSM 3	BSM 3D	BSM 4	BSM 5	BSM 6	BSM 7	BSM 8
7/25/2012	1	0.20	0.27	0.75	1.08	97%	95%	97%	97%	96%	-147%	81%	94%	97%
	2	0.19	0.53	0.75	2.16	97%	93%	97%	97%	96%	-132%	78%	93%	<b>96%</b>
	3	0.19	0.80	0.75	3.24	95%	91%	97%	97%	96%	-121%	73%	91%	95%
	4		1.02	0.60	4.10	95%	89%	97%	97%	96%	-121%	71%	86%	94%
7/26/2012	5	0.19	1.28	0.75	5.18	97%	94%	96%	96%	96%	-168%	78%	94%	96%
	6		1.55	0.75	6.26	97%	92%	96%	96%	96%	-147%	74%	94%	95%
	7		1.82	0.75	7.34	96%	89%	96%	96%	96%	-137%	71%	93%	94%
	8		2.03	0.60	8.20	96%	89%	96%	96%	96%	-132%	68%	93%	94%
7/31/2012	9	0.98	4.06	1.10	9.78	97%	87%	99%	99%	99%	20%	87%	91%	92%
	10		6.08	1.10	11.37	93%	76%	99%	97%	98%	8%	72%	82%	85%
	11		8.29	1.20	13.09	89%	72%	99%	94%	95%	5%	65%	77%	80%
8/1/2012	12	0.94	10.31	1.10	14.68	96%	84%	99%	98%	98%	6%	82%	93%	85%
	13		12.33	1.10	16.26	90%	73%	76%	22%	0%	-2%	67%	86%	76%
	14		14.54	1.20	17.99	86%	68%	73%	94%	89%	-2%	59%	81%	70%
8/2/2012	15	0.98	16.56	1.10	19.57	94%	78%	97%	96%	95%	-2%	82%	89%	80%
	16		18.59	1.10	21.15	87%	65%	97%	92%	89%	-12%	68%	82%	68%
	17		20.79	1.20	22.88	83%	61%	96%	92%	82%	-12%	58%	78%	62%
Median						95%	87%	97%	96%	96%	-12%	72%	91%	92%

## **APPENDIX D**

Design drawings, July 8, 2011, Robert Roseen, Engineer of Record  
Sheets 1-13.

# Bioretention Systems for “Tedeschi” Municipal Lot Pettee Brook Lane, Durham NH

July 8, 2011

## Project Partners

UNH Stormwater Center, Town of Durham, NH, US EPA Region 1



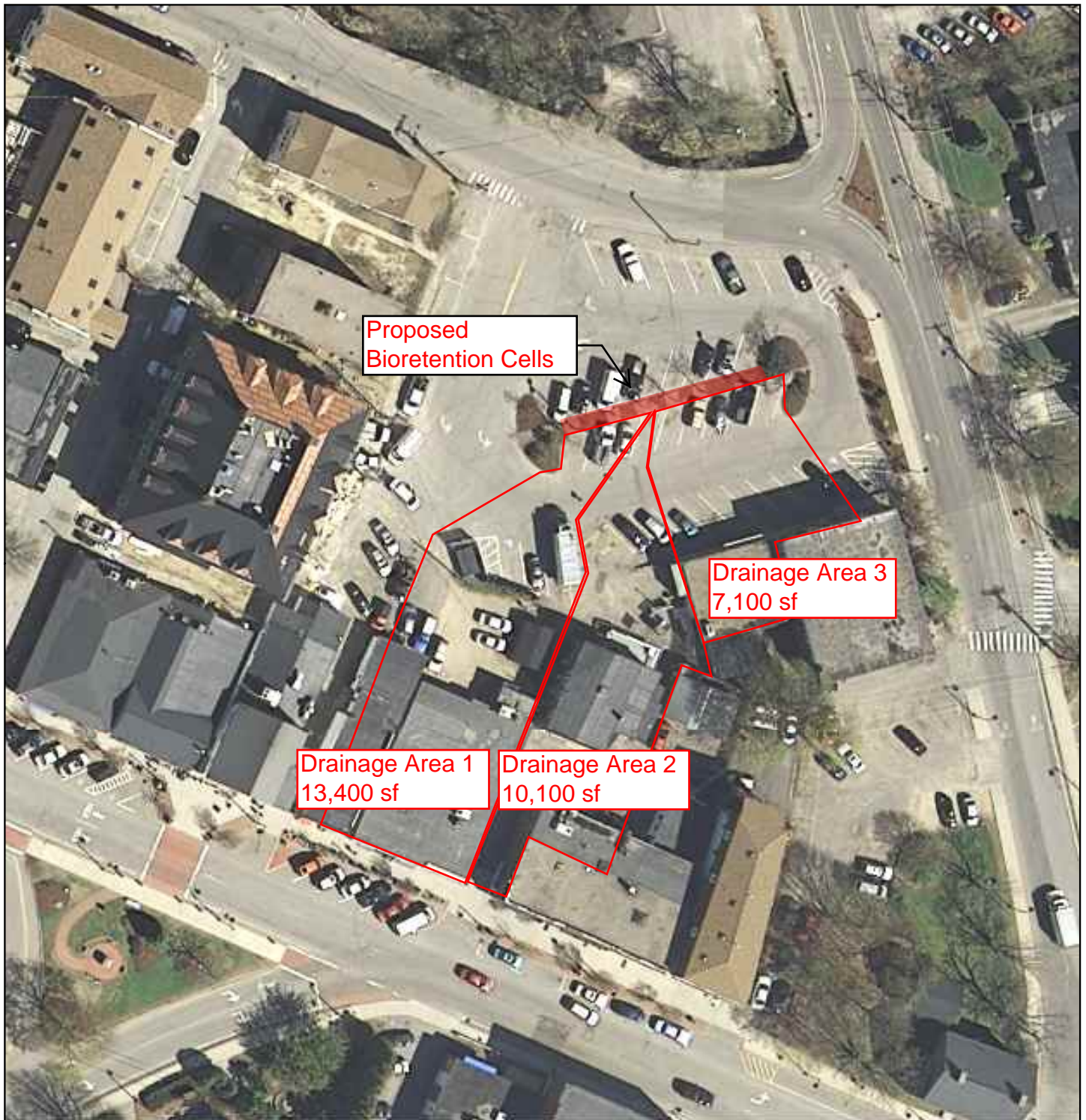
### ESTIMATED CONSTRUCTION SCHEDULE

July 11	Mobilization
July 12-13	Excavation and Sidewalk Forms
July 14-19	Cell Construction
July 20	Sidewalk Installation
July 20-22	Landscaping

Drawn By: VH, RJD
Reviewed By: JJH
Checked By: RMR
Date: 7/8/11

### INDEX

Sheet 1: Title Sheet and Index
Sheet 2: Site Location and Drainage Areas
Sheet 3: Bioretention Cell Layout—Overview
Sheet 4: Bioretention Cell Layout—Individual Cells
Sheet 5: Long Section Detail—Cell 1&2
Sheet 6: Cross Section Detail—Cell 1&2
Sheet 7: Long Section—Drainage Elevations and Details
Sheet 8: Curb Details
Sheet 9: Outlet Control Structures Detail
Sheet 10: Materials List Estimates
Sheet 11: Planting Plan
Sheet 12: Plant List
Sheet 13: Project Contacts---Names, Phone Numbers, Email



**Map Source:**

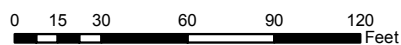
The aerial image was a 1-foot, color, 4-band aerial photographs for southern and central New Hampshire, collected in the spring of 2010 by the New Hampshire Department of Transportation and obtained from NH Granit GIS Services.

University of New Hampshire Stormwater Center

Drawing Title:



Drawn By: M. Bubier  
Reviewed By: R. Roseen/J. Houle  
Date Prepared: June 2011



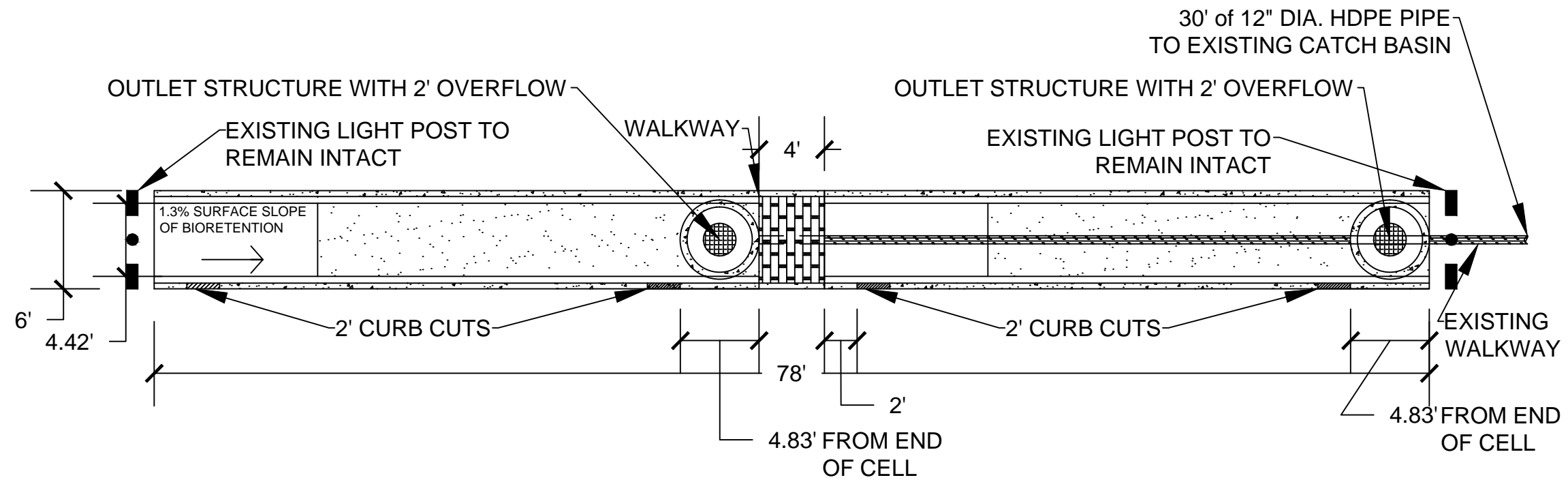
**Proposed Bioretention System  
for "Tedeschi" Municipal Lot**

Pettee Brook Lane  
Durham, NH

Sheet #: 2 of 13

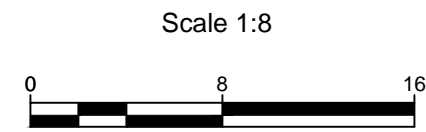
# Cell 1

# Cell 2



Legend:

Notes:  
 1-800-DIGSAFE  
 BIORETENTION & PIPE WORK AS ONE CONTRACT  
 FROM UNH.  
 COORDINATION OF THE TWO CONTRACTS AND TIMING ARE  
 RESPONSIBILITIES OF CONTRACTORS.  
 CONSTRUCTION TO BE COMPLETED BY 7/22/11

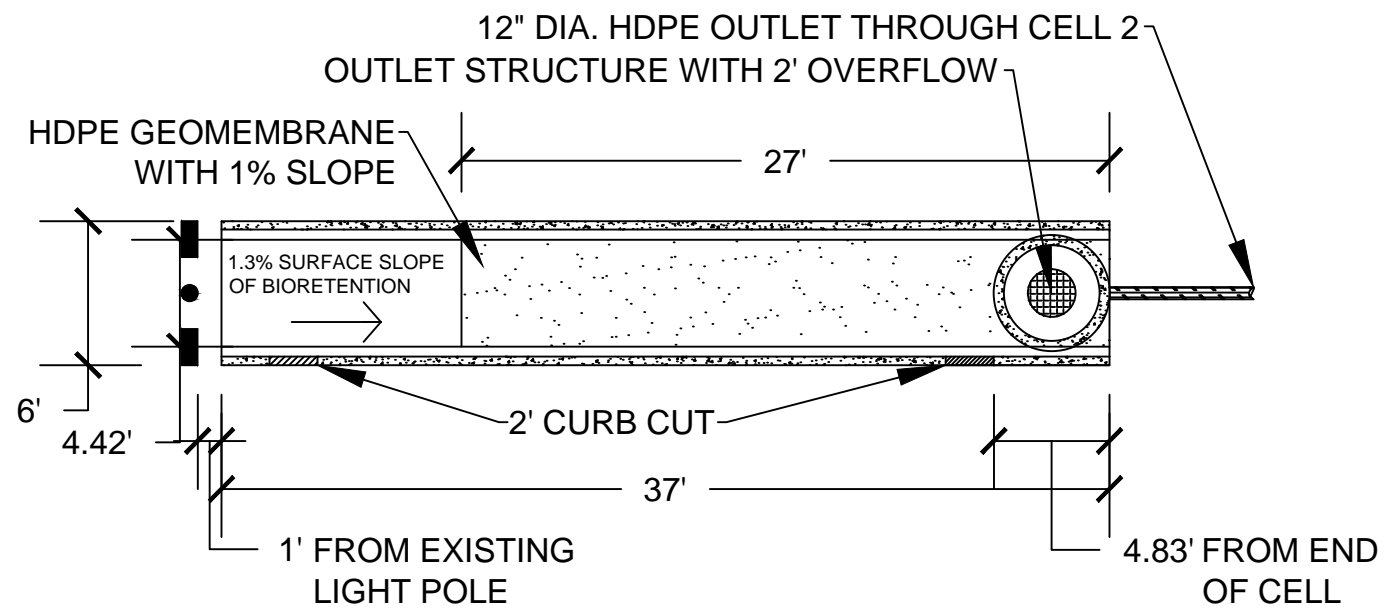


Drawn By: VH,RJD  
 Reviewed By: JJH  
 Checked By: RMR  
 Date: 7/7/2011

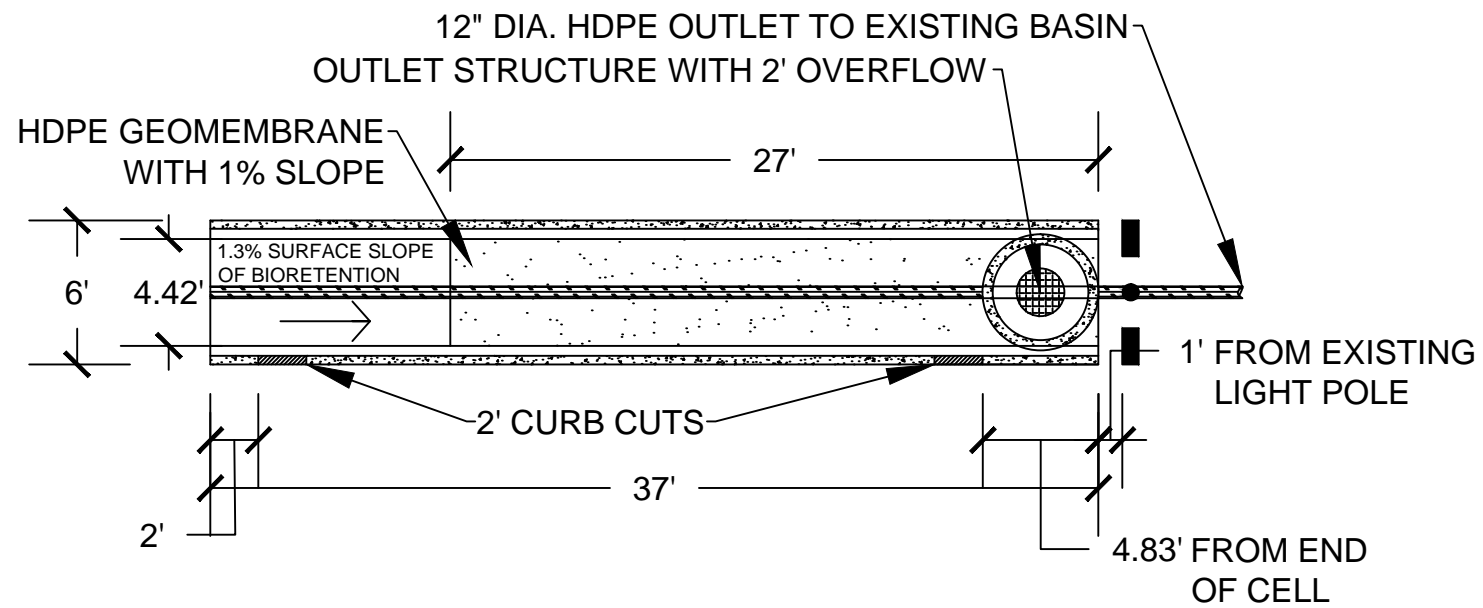
BIORETENTION CELL LAYOUT  
 TEDESCHI  
 5 MADBURY ROAD, DURHAM NH, 03824

Sheet No:  
 3 of 13  
 Revision:  
 4 of 4

**Cell 1**

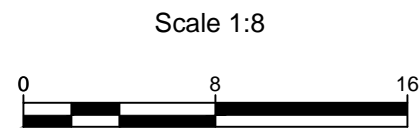


**Cell 2**



Legend:

Notes:  
 1-800-DIGSAFE  
 BIORETENTION & PIPE WORK AS ONE CONTRACT  
 FROM UNH.  
 COORDINATION OF THE TWO CONTRACTS AND TIMING ARE  
 RESPONSIBILITIES OF CONTRACTORS.  
 CONSTRUCTION TO BE COMPLETED BY 7/22/11



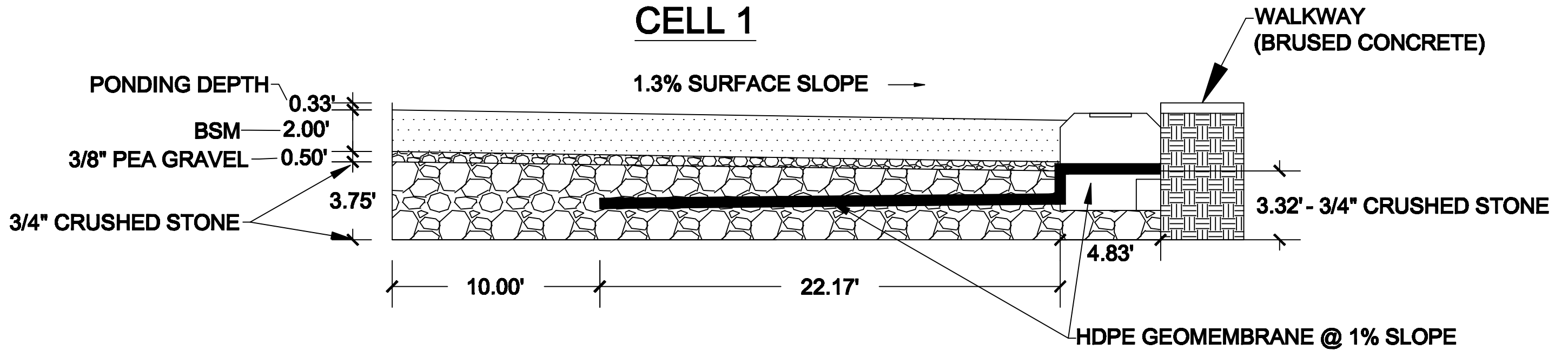
Drawn By: VH,RJD  
 Reviewed By: JJH  
 Checked By: RMR  
 Date: 7/11/2011

BIORETENTION LAYOUT  
 TEDESCHI  
 5 MADBURY ROAD, DURHAM NH, 03824

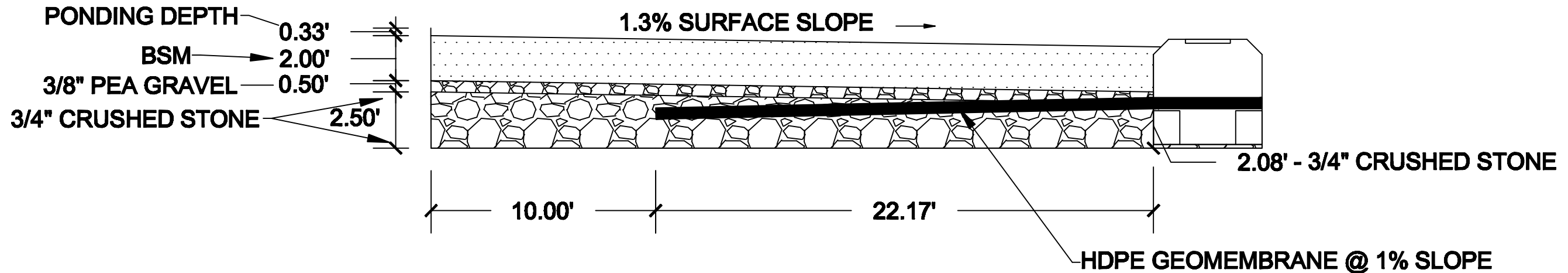
Sheet No:  
 4 of 13  
 Revision:  
 3 of 3



# CELL 1

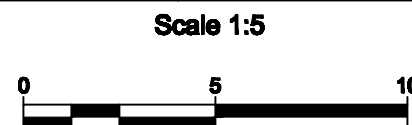


# CELL 2



Legend:

Notes:  
 1-800-DIGSAFE  
 BIORETENTION SOIL MIX MATERIALS TO BE PROVIDED BY UNHSC AND MIXED BY THE CONTRACTOR UNDER SUPERVISION OF UNHSC

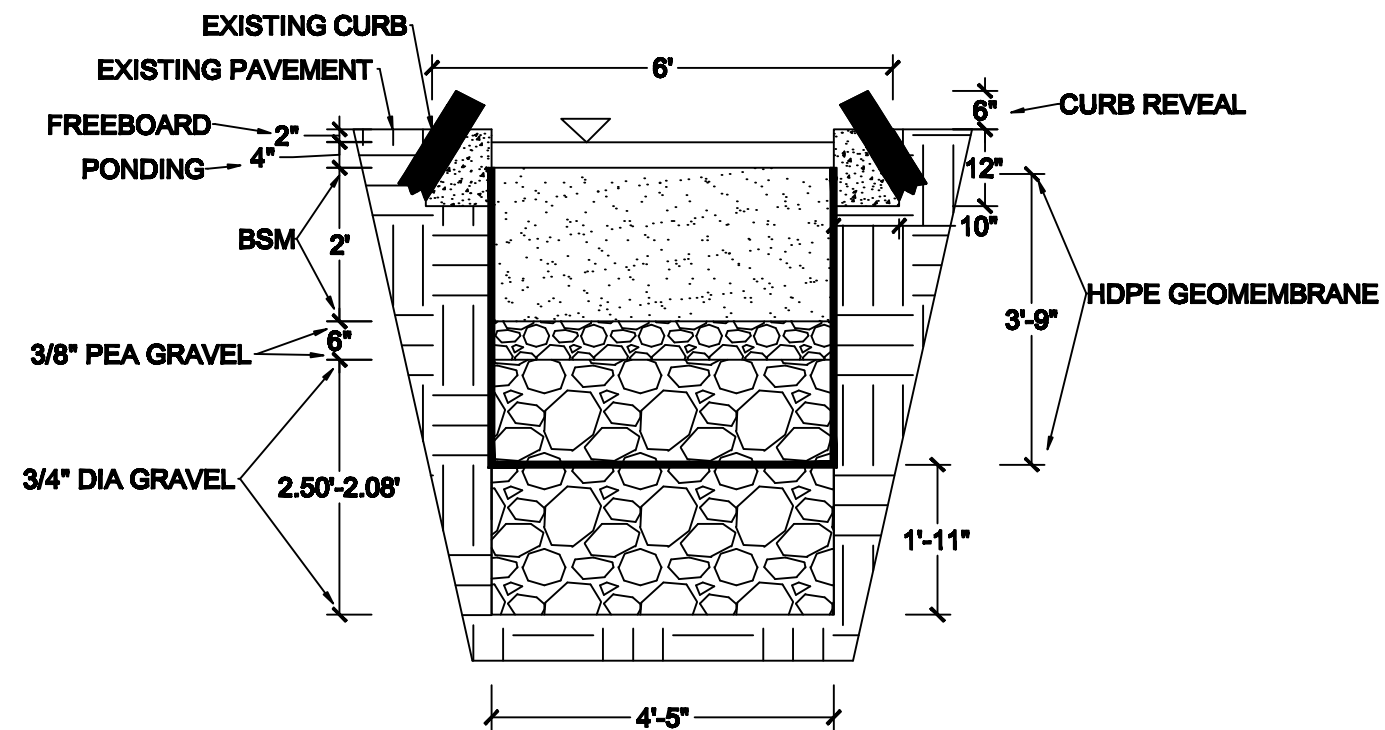


Drawn By: VH,RJD  
 Reviewed By: JJH  
 Checked By: RMR  
 Date: 7/8/2011

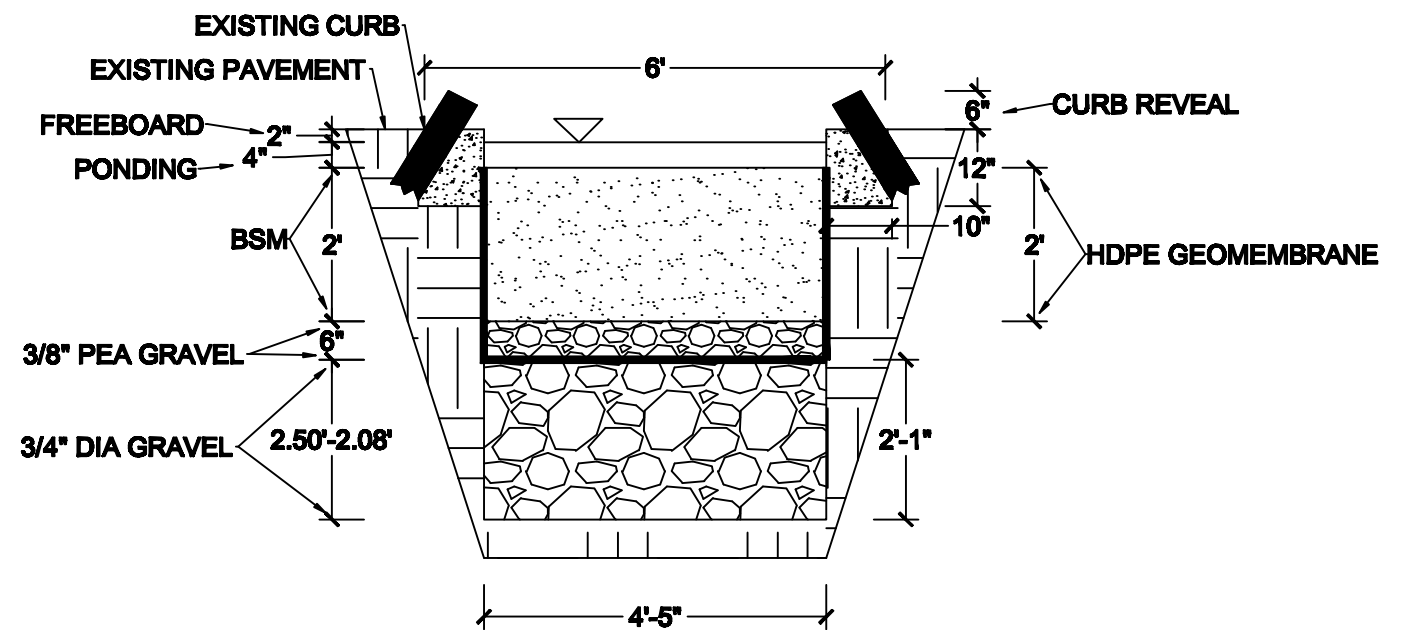
CELL 1 & 2 LONG SECTION DETAIL  
 TEDESCHI  
 5 MADBURY ROAD, DURHAM NH, 03824

Sheet No:  
 5 of 13  
 Revision:  
 4 of 4

### CELL 1

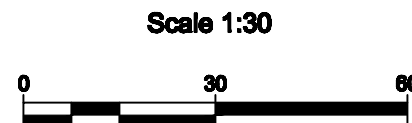


### CELL 2



Legend:

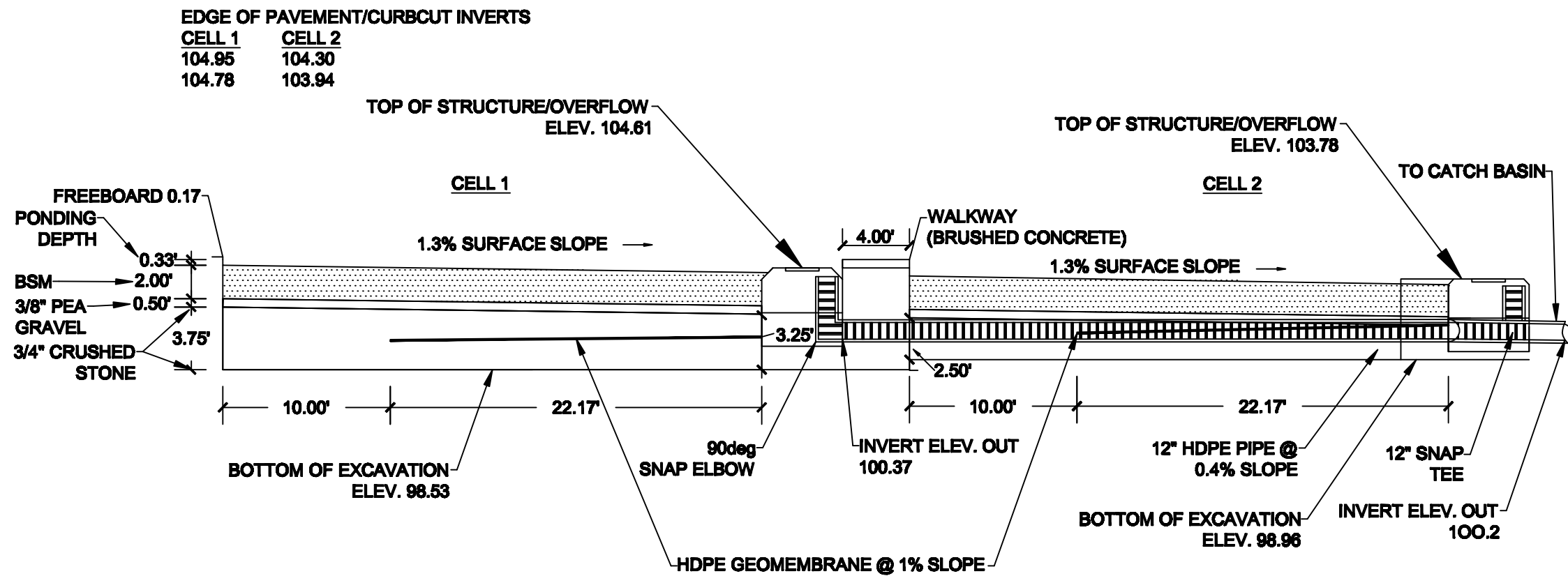
Notes:  
 1-800-DIGSAFE  
 GEOMEMBRANE, 20 MIL MIN  
 CROSS SECTIONS ARE DRAWN AT  
 ABUTMENT OF OUTFALL STRUCTURES



Drawn By: VH,RJD  
 Reviewed By: JJH  
 Checked By: RMR  
 Date: 7/8/2011

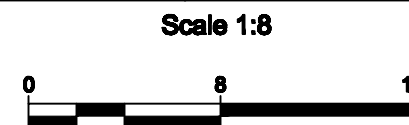
CELL 1 & 2 SECTION DETAIL  
 TEDESCHI  
 5 MADBURY ROAD, DURHAM NH, 03824

Sheet No:  
 6 of 13  
 Revision:  
 4 of 4



Legend:

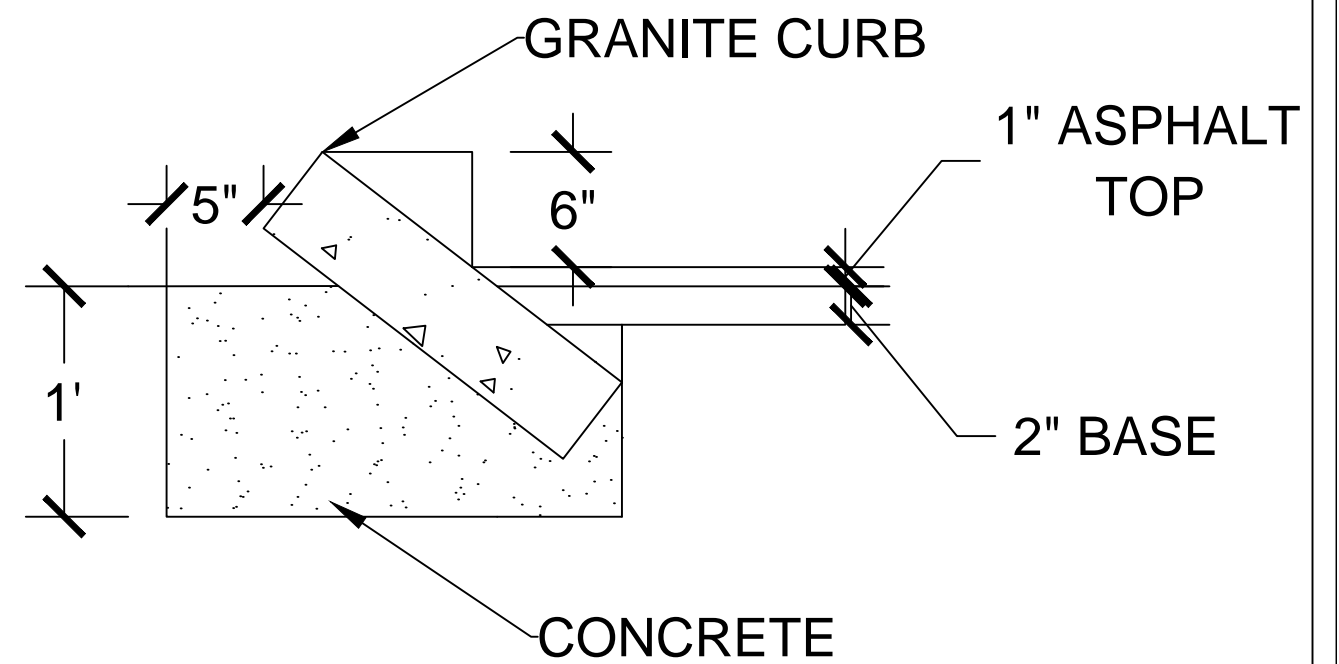
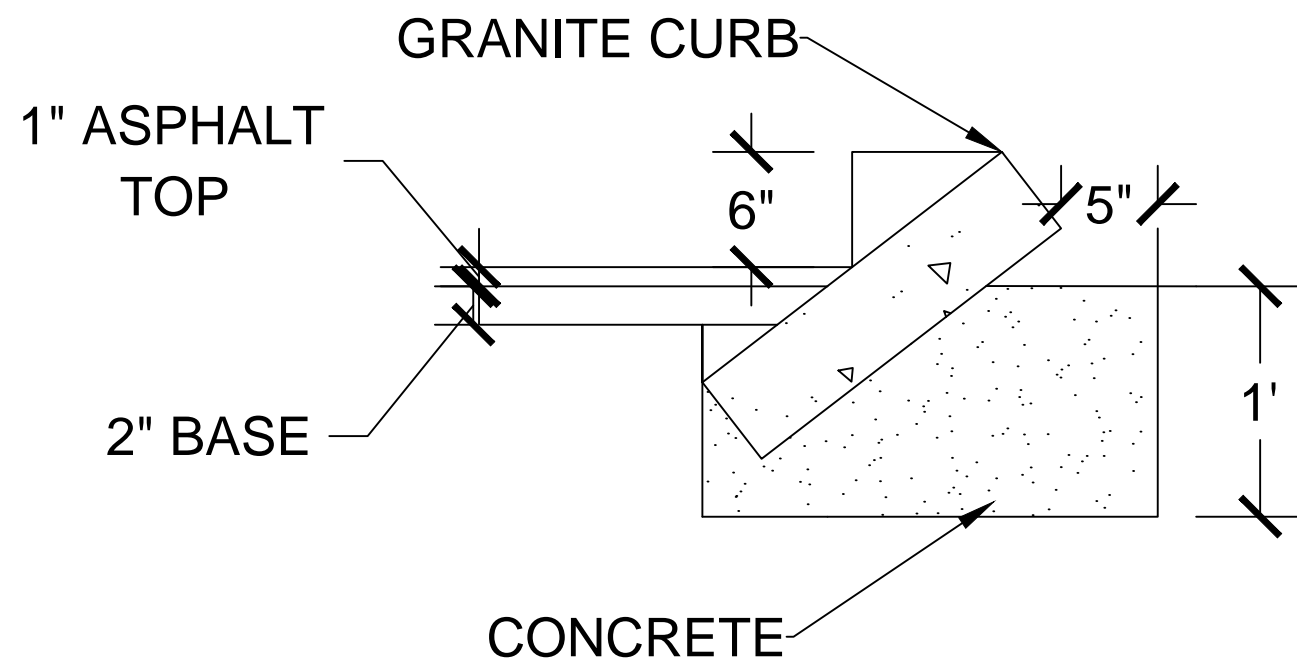
Notes:  
 1-800-DIGSAFE  
 ELEVATIONS ARE RELATIVE TO THE  
 INVERT OF THE 12" PIPE IN THE EXISTING  
 CATCH BASIN AND HAS BEEN SET AT  
 100.00'



Drawn By: VH,RJD  
 Reviewed By: JJH  
 Checked By: RMR  
 Date: 7/8/2011

PIPE DETAIL  
 TEDESCHI  
 5 MADBURY ROAD, DURHAM NH 03824

Sheet No:  
 7 of 13  
 Revision:  
 3 Of 3



Legend:

Notes:  
1-800-DIGSAFE

Scale 1:8



Drawn By: VH,RJD  
Reviewed By: JJH  
Checked By: RMR  
Date: 7/11/2011

CURB DETAIL

TEDESHCI

5 MADBURY ROAD, DURHAM NH, 03820

Sheet No:  
8 of 13

Revision:  
5 of 5

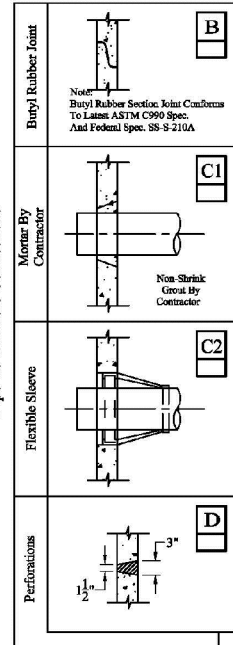
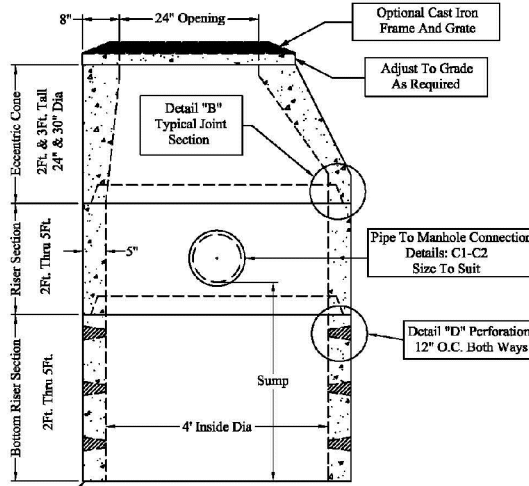
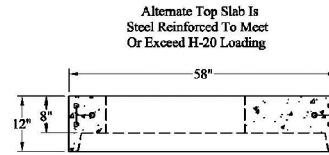
1-800-639-2199

Fax (603) 224-2927

Drywell/Box/Leaching Basin/Opem Bottom/1

Phoenix Precast Products

Phoenix Precast Products



See General Note 1

Required Sump Area \_\_\_\_\_

- General Notes**
- 1.) Steel Reinforcement Conforms To Latest ASTM Specifications: ASTM A-615 Grade 60 Rebar  
ASTM A-185 Welded Wire Fabric 0.12 Square Inch / Linear Foot And 0.12 Square Inch (Both Ways) Base Bottom
  - 2.) Concrete:  $f_c = 4,000$  psi @ 28 Days Minimum
  - 3.) Design Loading: AASHTO-HS20-44  
Manhole Design Conforms To The Latest ASTM C478 Specifications For "Precast Reinforced Concrete Manhole Sections".
  - 4.) Optional Cast Covers or Concrete Covers Available
  - 5.) Hole Coring Available for Larger Diameter Pipes

Phoenix Precast Products 4' Diameter Leaching Basin Open Bottom Type I

Notes:  
PHOENIX DRAWING

13Feb09\_Rev2a 77 Regional Drive Concord, NH 03301



Scale NTS

Drawn By:  
Reviewed By:  
Checked By:  
Date: 7/8/2011

Catch Basin Detail  
Tedeschi  
5 Madbury Road, Durham NH, 03824

Sheet No:  
9 Of 13  
Revision:

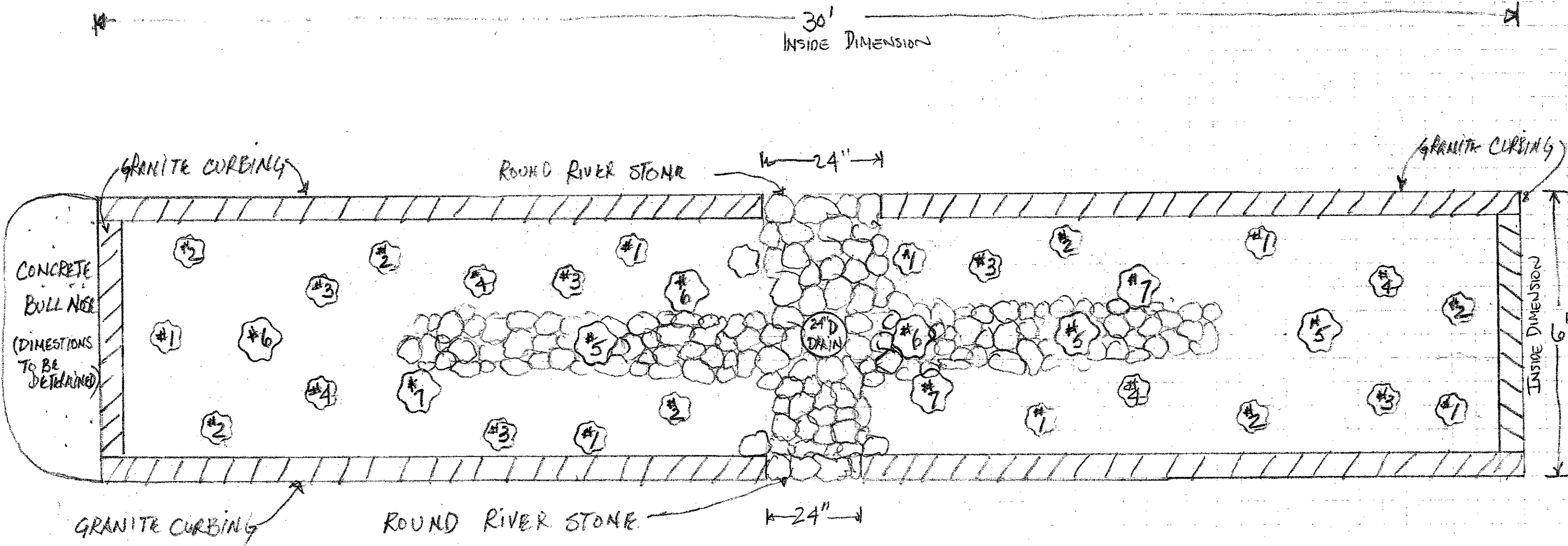


## Bioretention Materials List Estimate

**Project Name:** Tedeschi  
5 Madbury Road, Durham, NH, 03824

Date: 7/8/2011

Item ID	Description	Unit	Quantity	Unit Price	Cost	Order Date	Date Completed	Supplier	Notes
1.0	BSM MIX: 50% Sand/15% Compost/5% WTR/20% Woodchips/10% Soil	C.Y	32.0						
1.1	Sand	C.Y	14.0	\$20.50	\$287.00			LandCare	Delivery not incl.
1.2	Compost	C.Y	6.0	\$34.00	\$204.00			LandCare	Delivery not incl.
1.3	WTR	C.Y	2.0	NA	NA			Durham WTF	
1.4	Woodchips	C.Y	6.0	\$11.00	\$66.00			LandCare	Delivery not incl.
	Top Soil	C.Y	4	\$21.00	\$84.00			LandCare	
2.0	3/8" Pea Gravel	C.Y	8	\$44.00	\$352.00			LandCare	Price quote is for 1/2" PG
3.0	3/4" Crushed Stone	C.Y	52	\$27.00	\$1,404.00			NA	
4.0	12" HDPE Pipe	(ft)	85					EJP	Shorelock wo/sock
4.1	12" Snap Tee	each	1					EJP	Shorelock wo/sock
4.2	12" 90 Snap Elbow	each	1					EJP	Part # 0626AA
4.3	24" Circular Flat Grate	each	2					EJP	Part # 0612AA
5.0	Plantations	NA	NA	NA	NA				
Item ID	Description	Unit	Quantity	Unit Price	Cost	Order Date	Date Completed	Supplier	Notes
7.0	20 mil HDPE geomembrane	sf	648	\$0.80	\$518.40				
	<b>Summary of Costs</b>				<b>\$2,915.40</b>				



DURHAM BIORETENTION  
 PLANTING + STONE PLAN  
 LANDSCAPE MATTERS, LLC  
 PAUL T JAMES  
 SCALE: 1/2" = 1'  
 JUNE 6, 2011

**LANDSCAPE MATTERS, LLC**  
2 Bourn Avenue  
Hampton, NH 03842  
603-235-2894

**CUSTOMER:** Robert M Roseen  
Director, The UNH Stormwater Center  
Dept. of Civil Engineering  
35 Colovos Rd  
University of New Hampshire  
Durham, NH 03824

**Plant List Key for Durham Bio Retention**

June 6, 2011

DESCRIPTION		
<b>Plant Varieties:</b>  (7) Rudbeckia 'Goldstrum' #1 (7) Perovskia (Russian Sage) #2 (5) Helianthus 'Lemon Queen' #3 (5) Helenium 'Mardis Gras' #4 (3) Miscanthus strictus #5 (3) Miscanthus 'Sarabande' #6 (3) Miscanthus 'Heron Sunrise' #7		





## Bioretention Project Contact List

**Project Name:** Tedeschi  
5 Madbury Road, Durham, NH, 03824

Date: 7/8/2011

Name	Company	Title	Contact Info.	Notes
<b>Rob Dowling</b>	UNHSC		c. 603-370-7072	
			email <a href="mailto:rje7@unh.edu">rje7@unh.edu</a>	
<b>Robert Roseen</b>	UNHSC		o. 603-862-4024	
			c. 603-686-2488	
			email <a href="mailto:robert.roseen@unh.edu">robert.roseen@unh.edu</a>	
<b>Jerry Mailloux</b>	Phoenix		603-231-1685	
			email <a href="mailto:jmailloux@phoenixprecast.com">jmailloux@phoenixprecast.com</a>	
<b>Jamie Houle</b>	UNHSC		c. 603-767-7091	Onsite oversight
			email <a href="mailto:james.houle@unh.edu">james.houle@unh.edu</a>	
<b>Viktor Hlas</b>	UNHSC		c. 603-841-0653	Design work
			email <a href="mailto:vir3@unh.edu">vir3@unh.edu</a>	
<b>David Cedarholm</b>	Durham Pub	Town Eng.	o. 603-868-5578	
			email <a href="mailto:dcedarholm@ci.durham.nh.us">dcedarholm@ci.durham.nh.us</a>	
<b>Michael Lynch</b>	Durham Pub	Director	o. 603-868-5578	
			email <a href="mailto:publicworks@ci.durham.nh.us">publicworks@ci.durham.nh.us</a>	
<b>Michael Alesse</b>		Contractor	o. 978-521-0775	
			c. 508-328-7267	
			email <a href="mailto:MKalesse@comcast.net">MKalesse@comcast.net</a>	

## **APPENDIX E**

**Bio-5 Cell 2 Monitoring Data**

**Bio-5 Cell 1 Monitoring Data**

**Bio-5 Cell 1 Time Series Figures**

**Table 48. Bio-5 Cell 2 Data for all monitored storms.**

Storm Date	Total Phosphorus (mg/L)			Orthophosphate (mg/L)			SSC (mg/L)			TSS (mg/L)		
	Influent	Effluent	RE	Influent	Effluent	RE	Influent	Effluent	RE	Influent	Effluent	RE
10/13/2011	0.49	0.03	94%	0.016	0.011	31%	120	3	98%	79	3	96%
10/19/2011	0.11	0.06	45%	0.015	0.012	20%	120	10	92%	180	140*	22%
11/10/2011	0.2	0.09	55%	0.018	0.007	61%	120	66	45%	170	54	68%
12/6/2011	0.13	0.07	46%	0.01	0.013	-30%	82	29	65%	68	31	54%
1/23/2012	0.94	0.23	76%	0.002	0.08	-3900%		26		770	48	94%
1/26/2012	0.25	0.07	72%	0.003	0.009	-200%	220	54	75%	200	51	75%
6/22/2012	0.16	0.05	69%	0.016	0.013	19%				130	14	89%
7/17/2012	0.34	0.12	65%	0.027	0.012	56%				200	22	89%
7/26/2012	0.28	0.19	32%	0.016	0.009	44%				230	74	68%
8/5/2012		0.07			0.01					150	8	95%
8/10/2012	0.02	0.06	-200%	0.01	0.023	-130%				12	18	-50%
8/28/2012	0.36	0.33	8%	0.028	0.044	-57%				300	160	47%
9/8/2012	0.15	0.07	53%	0.008	0.013	-63%				84	10	88%
9/28/2012	0.06	0.06	0%	0.002	0.01	-400%				28	9	68%

Continued from previous page.

Storm Date	Total Nitrogen (mg/L)			Total Kjeldahl Nitrogen (mg/L)			Soluble Kjeldahl as N (mg/L)			Particulate TKN (mg/L)		
	Influent	Effluent	RE	Influent	Effluent	RE	Influent	Effluent	RE	Influent	Effluent	RE
10/13/2011	7.5	0.7	91%	7.5	0.7	91%						
10/19/2011	1.1	0.8	27%	1.1	0.8	27%						
11/10/2011	1	0.8	20%	1	0.8	20%						
12/6/2011	1.4	0.7	50%	1.4	0.7	50%						
1/23/2012	4.6	5.9	-28%	4.6	5.9	-28%						
1/26/2012	< 0.5	< 2.0		< 0.5	0.8		0.7	0.7	0%		0.1	
6/22/2012	2.5	1.1	56%	2.2	1.1	50%	1.1	1.1	0%	1.1	0	100%
7/17/2012	3.2	1.8	44%	2.7	1.6	41%	1.5	1.3	13%	1.2	0.3	75%
7/26/2012	2.1	1.7	19%	1.6	1.5	6%	0.7	1.6	-129%	0.9	-0.1	111%
8/5/2012		1.4			1.3			1.1				
8/10/2012	1.1	1.2	-9%	1	1	0%	1	0.8	20%	0	0.2	
8/28/2012	3.2	1.3	59%	3.2	1.2	63%	0.9	0.8	11%	2.3	0.4	83%
9/8/2012	1.6	0.9	44%	1.6	0.9	44%	0.7	0.8	-14%	0.9	0.1	89%
9/28/2012	0.9	0.7	22%	0.9	0.6	33%	0.6	0.7	-17%	0.3	-0.1	133%

Continued from previous page.

Storm Date	Ammonia (mg/L)			Soluble Ammonia as N (mg/L)			Particulate NH4 (mg/L)			Nitrate (mg/L)			Nitrite (mg/L)		
	Influent	Effluent	RE	Influent	Effluent	RE	Influent	Effluent	RE	Influent	Effluent	RE	Influent	Effluent	RE
10/13/2011	< 0.5	< 0.5								< 0.1	< 0.1		< 0.1	< 0.1	
10/19/2011	< 0.5	< 0.5								< 0.1	< 0.1		< 0.1	< 0.1	
11/10/2011	< 0.5	< 0.5								< 0.1	< 0.1		< 0.1	< 0.1	
12/6/2011	< 0.5	< 0.5								< 0.1	< 0.1		< 0.1	< 0.1	
1/23/2012	< 0.5	1.1								< 0.5	< 0.5		< 0.1	< 0.1	
1/26/2012	< 0.5	< 0.5		< 0.5	< 0.5					< 0.1	< 2.0		< 0.1	< 0.1	
6/22/2012	< 0.5	< 0.5		< 0.5	< 0.5					0.3	0.05	83%	< 0.1	< 0.1	
7/17/2012	0.6	0.25	58%	0.5	0.5	0%	0.1	-0.25		0.5	0.2	60%	< 0.1	< 0.1	
7/26/2012	0.7	0.25	64%	< 0.5	0.6					0.5	0.2	60%	< 0.1	< 0.1	
8/5/2012		< 0.5			< 0.5						0.2			< 0.1	
8/10/2012	< 0.5	< 0.5		< 0.5	< 0.5					0.1	0.2	-100%	< 0.1	< 0.1	
8/28/2012	< 0.5	< 0.5		< 0.5	< 0.5					< 0.1	0.2		< 0.1	< 0.1	
9/8/2012	< 0.5	< 0.5		< 0.5	< 0.5					< 0.1	< 0.1		< 0.1	< 0.1	
9/28/2012	< 0.5	< 0.5								< 0.1	< 0.1		< 0.1	< 0.1	

Continued from previous page.

Storm Date	Zinc (mg/L)			TPH-D (ug/L)			2-fluorobiphenyl SUR (%)			o-terphenyl SUR (%)		
	Influent	Effluent	RE	Influent	Effluent	RE	Influent	Effluent	% Recovery	Influent	Effluent	% Recovery
10/13/2011	0.29	0.005	98%	3000	160	95%	96	80	83%	104	91	88%
10/19/2011	0.07	0.02	71%	1300	160	88%	95	84	88%	105	97	92%
11/10/2011	0.09	0.005	94%	710	160	77%	71	69	97%	64	64	100%
12/6/2011	0.1	0.04	60%	580	160	72%	74	72	97%	73	79	108%
1/23/2012	0.61	0.15	75%	7900	370	95%	79	65	82%	67	67	100%
1/26/2012	0.14	0.09	36%	1300	370	72%	52	65	125%	64	74	116%
6/22/2012	0.16	0.005	97%									
7/17/2012												
7/26/2012	0.15	0.06	60%									
8/5/2012		0.01										
8/10/2012	0.03	0.02	33%									
8/28/2012												
9/8/2012												
9/28/2012												

\* Sample compromised en route to the lab.

Storms disqualified due to bypass or lack of coverage.

Storms disqualified for nitrogen due to lack of system ripening.

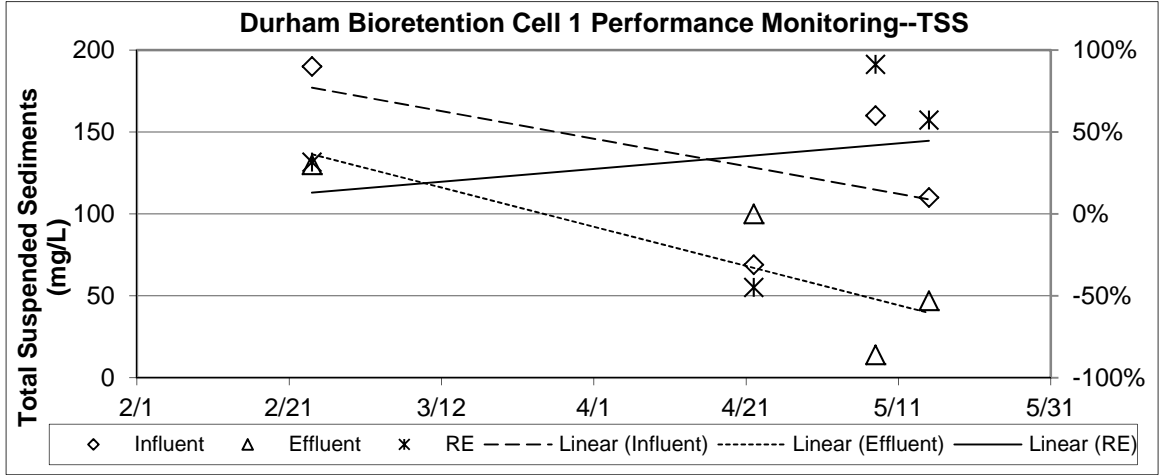
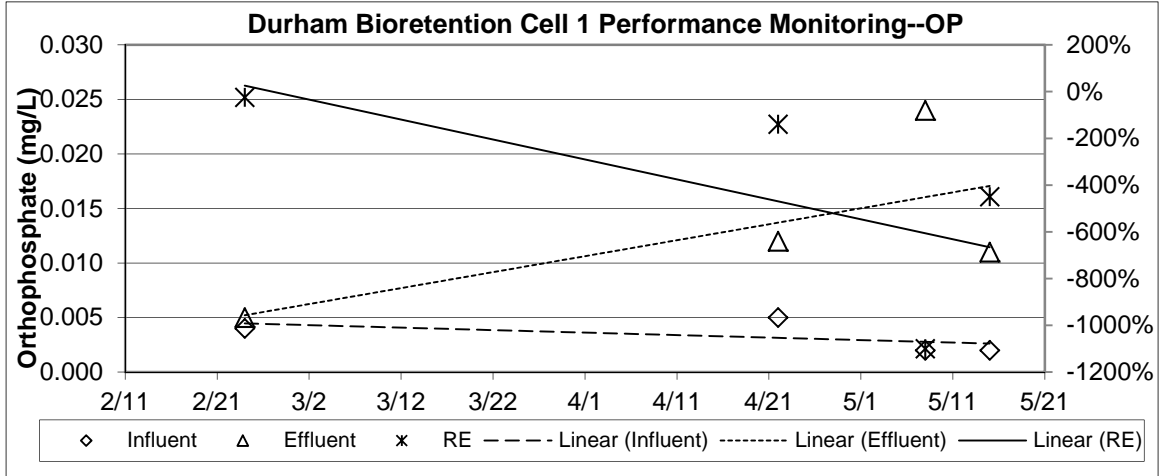
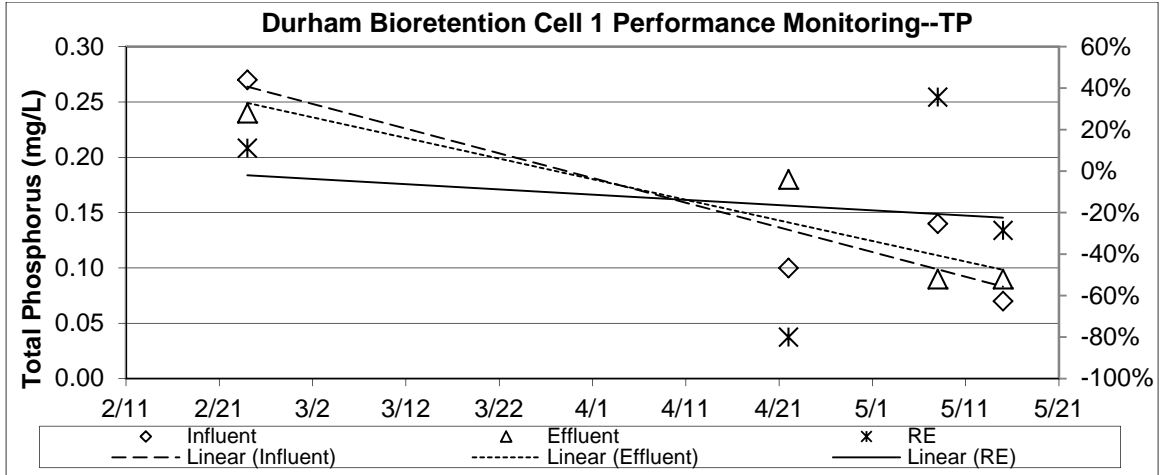
Value returned as Below Detection Limit (BDL). Recorded here as half of the Detection Limit (DL).

**Table 49. Bio-5 Cell 1 Data for all monitored storms.**

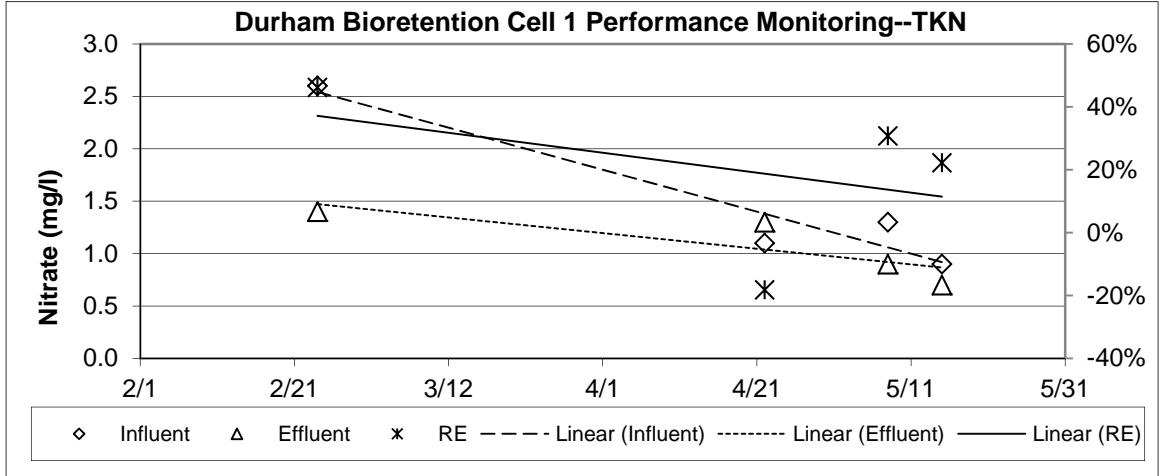
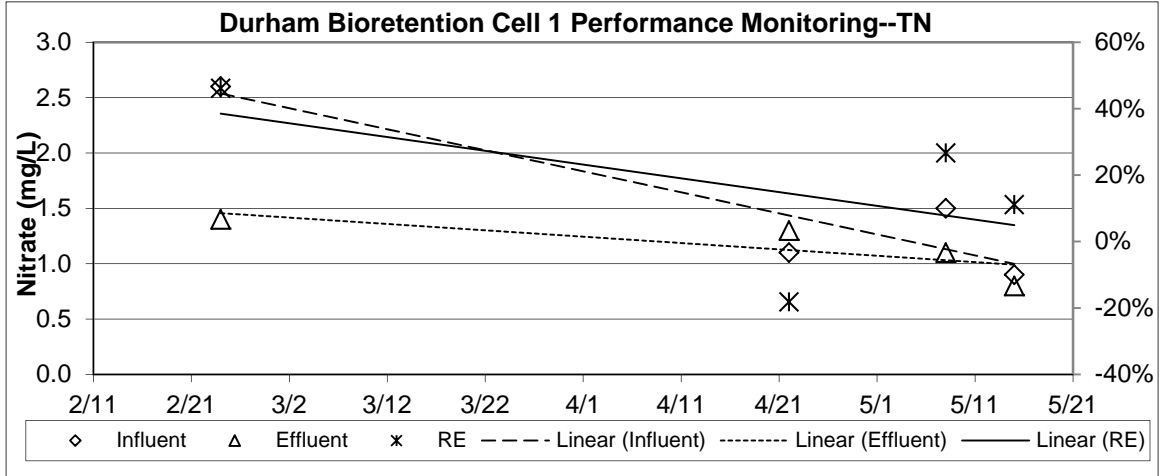
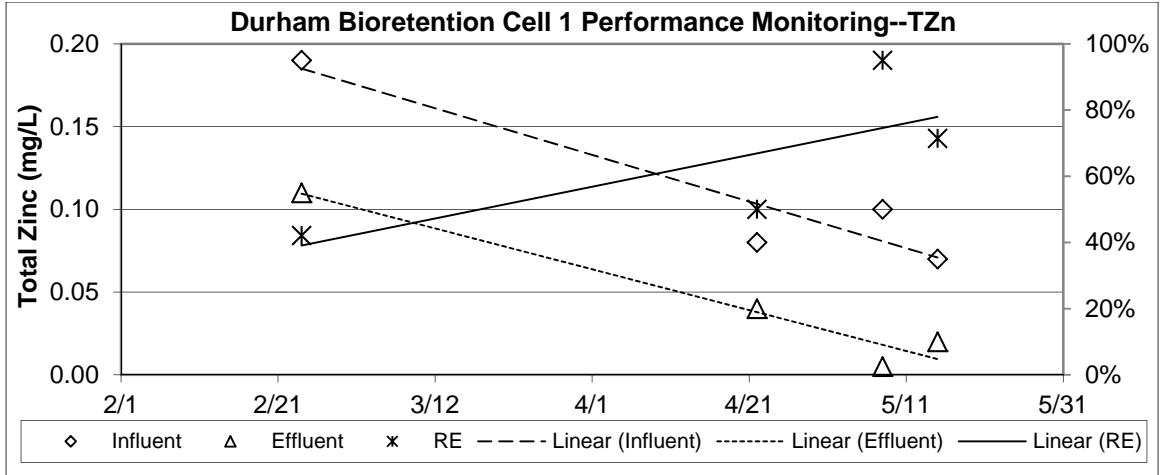
Storm Date	Total Phosphorus (mg/L)			Orthophospate (mg/L)			TSS (mg/L)			Zinc (mg/L)		
	Influent	Effluent	RE	Influent	Effluent	RE	Influent	Effluent	RE	Influent	Effluent	RE
2/24/2012	0.27	0.24	11%	0.004	0.005	-25%	190	130	32%	0.19	0.11	42%
4/22/2012	0.1	0.18	-80%	0.005	0.012	-140%	69	100	-45%	0.08	0.04	50%
5/8/2012	0.14	0.09	36%	0.002	0.024	-1100%	160	14	91%	0.1	0.005	95%
5/15/2012	0.07	0.09	-29%	0.002	0.011	-450%	110	47	57%	0.07	0.02	71%

Storm Date	Total Nitrogen (mg/L)			Total Kjeldahl Nitrogen (mg/L)			Soluble Kjeldahl as N (mg/L)			Particulate TKN (mg/L)		
	Influent	Effluent	RE	Influent	Effluent	RE	Influent	Effluent	RE	Influent	Effluent	RE
2/24/2012	2.6	1.4	46%	2.6	1.4	46%	< 0.5	0.5			0.9	
4/22/2012	1.1	1.3	-18%	1.1	1.3	-18%	0.5	0.8	-60%	0.6	0.5	17%
5/8/2012	1.5	1.1	27%	1.3	0.9	31%	1.1	1.1	0%			
5/15/2012	0.9	0.8	11%	0.9	0.7	22%	1	0.8	20%			

Storm Date	Ammonia (mg/L)			Soluble Ammonia as N (mg/L)			Nitrate (mg/L)			Nitrite (mg/L)		
	Influent	Effluent	RE	Influent	Effluent	RE	Influent	Effluent	RE	Influent	Effluent	RE
2/24/2012	< 0.5	< 0.5		< 0.5	< 0.5		< 0.1	< 0.1		< 0.1	< 0.1	
4/22/2012	< 0.5	0.8		< 0.5	< 0.5		< 0.1	< 0.1		< 0.1	< 0.1	
5/8/2012	< 0.5	< 0.5		0.6	0.25	58%	0.2	0.2	0%	< 0.1	< 0.1	
5/15/2012	< 0.5	< 0.5		< 0.5	< 0.5		< 0.1	0.1		< 0.1	< 0.1	







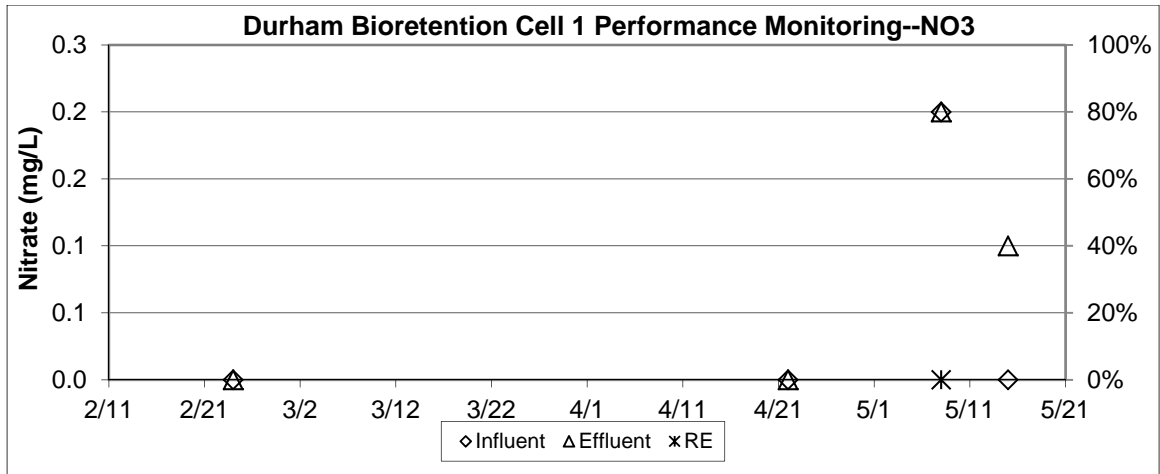


Figure 39. Time Series Water Quality Data for Bio-5 Cell 1.